

Brought to you by Eris Studios
NOT FOR RESALE

LIGHTING SYSTEM

GENERAL DESCRIPTION

LIGHTING SYSTEM

1. General Description

A: SPECIFICATIONS

Headlight			12 V — 55 W/60 W (Halogen)
			D2R 35W (HID)
Front turn signal light			12 V — 21 W
Clearance/Parking/Front side marker light			12 V — 5 W
Front fog light			12 V — 55 W
Rear combination light	Sedan	Tail/Stop/Rear side marker light	12 V — 5/21 W
		Tail light	12 V — 5/21 W
		Stop light	12 V — 21 W
	Wagon	Tail/Stop/Rear side marker light	12 V — 5/21 W
		Turn signal light	12 V — 21 W
		Back-up light	12 V — 21 W
License plate light			12 V — 5 W
High-mounted stop light	Sedan	Standard type	12 V — 21 W
		Rear spoiler built-in type	12 V — 1.2 W (LED)
	Wagon		12 V — 13 W
Room light			12 V — 8 W
Spot light			12 V — 8 W
Luggage room light			12 V — 13 W
Trunk room light			12 V — 5 W
Glove box light			12 V — 1.4 W

B: PRECAUTIONS

- Before disassembling or reassembling parts, always disconnect the battery ground cable. When replacing radio, control module, and other parts provided with memory functions, record memory contents before disconnecting the battery ground cable. Otherwise, the memory will be erased.
- Reassemble in reverse order of disassembly, unless otherwise indicated.
- Adjust parts to the given specifications.
- Connect the connectors and hoses securely during reassembly.
- After reassembly, make sure functional parts operate smoothly.

WARNING:

- **Airbag system wiring harness is routed near electrical parts and switches. All airbag system wiring harnesses and connectors are yellow. Do not use electric test equipment on these circuits.**
- **Be careful not to damage the airbag system wiring harness when servicing electrical parts and switches.**

C: PREPARATION TOOL

1. GENERAL TOOLS

TOOL NAME	REMARKS
Circuit Tester	Used for measuring resistance and voltage.

2. Headlight and Tail Light System

A: SCHEMATIC

1. HALOGEN TYPE HEADLIGHT

<Ref. to WI-135, SCHEMATIC, Headlight System.>

2. HID TYPE HEADLIGHT

<Ref. to WI-135, SCHEMATIC, Headlight System.>

3. CLEARANCE LIGHT AND ILLUMINATION LIGHT

<Ref. to WI-127, SCHEMATIC, Clearance Light and Illumination Light System.>

B: INSPECTION

1. HEADLIGHT SWITCH

<Ref. to LI-9, INSPECTION, Combination Switch (Light).>

2. HEADLIGHT RELAY

Measure the headlight relay resistance between terminals when connecting terminal No. 4 to battery positive terminal and terminal No. 3 to battery ground terminal.

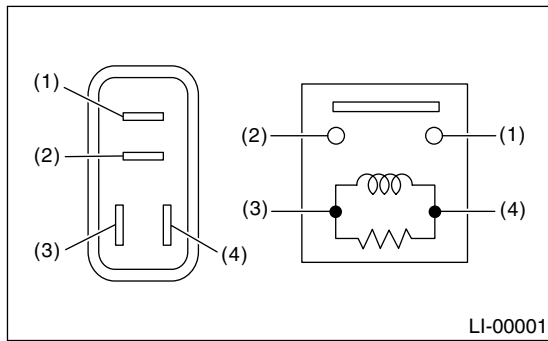

Current	Terminal No.	Standard
Flow	1 and 2	Less than 1 Ω
No flow		More than 1 MΩ

3. TAIL AND ILLUMINATION RELAY

Measure the tail and illumination relay resistance between terminals when connecting terminal No. 4 to battery positive terminal and terminal No. 3 to battery ground terminal.

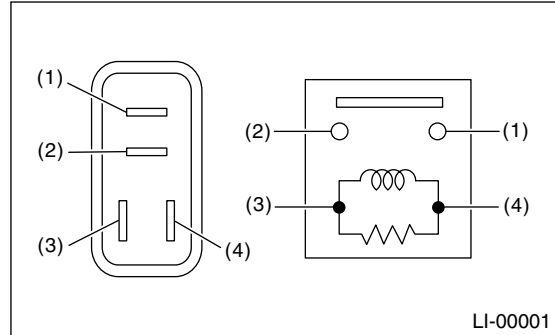

Current	Terminal No.	Standard
Flow	1 and 2	Less than 1 Ω
No flow		More than 1 MΩ

3. Front Fog Light System

A: SCHEMATIC

1. FRONT FOG LIGHT

<Ref. to WI-133, SCHEMATIC, Front Fog Light System.>

B: INSPECTION

1. FRONT FOG LIGHT SWITCH

Measure the front fog light switch resistance.

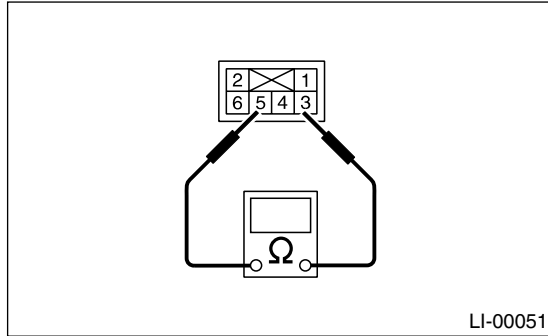

Switch position	Terminal No.	Standard
OFF	3 and 5	More than 1 MΩ
ON		Less than 1 Ω

2. FRONT FOG LIGHT RELAY

Measure the front fog light relay resistance between terminals when connecting terminal No. 4 to battery positive terminal and terminal No. 3 to battery ground terminal.

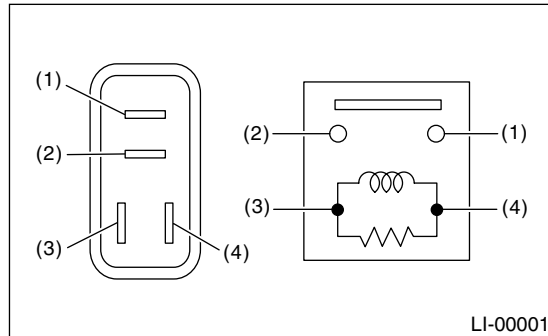

Current	Terminal No.	Standard
Flow	1 and 2	Less than 1 Ω
No flow		More than 1 MΩ

4. Turn Signal and Hazard Light System

A: SCHEMATIC

1. TURN SIGNAL LIGHT AND HAZARD LIGHT

<Ref. to WI-142, SCHEMATIC, Turn Signal Light and Hazard Light System.>

B: INSPECTION

1. TURN SIGNAL SWITCH

<Ref. to LI-9, INSPECTION, Combination Switch (Light).>

2. HAZARD SWITCH

Measure the hazard switch resistance.

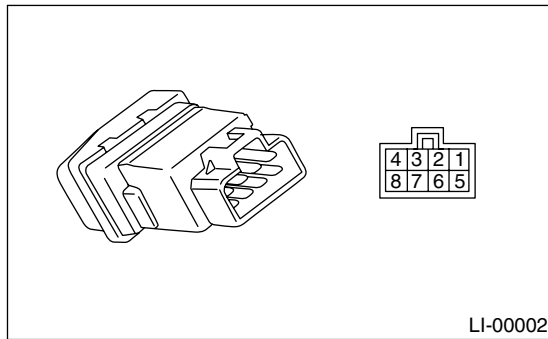

Switch position	Terminal No.	Standard
OFF	6 and 7	Less than 1 Ω
ON	1, 3 and 4	Less than 1 Ω
	7 and 8	Less than 1 Ω

3. TURN SIGNAL AND HAZARD MODULE

Connect the battery and turn signal light bulb to the module, as shown in the figure. The module is properly functioning if it blinks when power is supplied to the circuit.

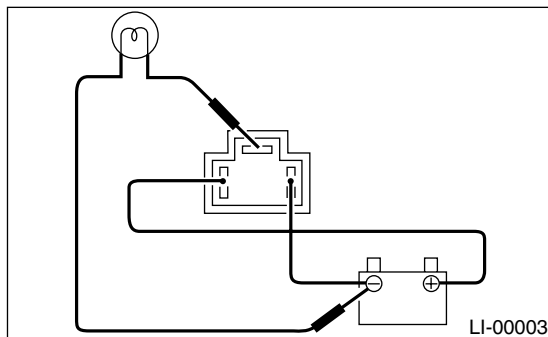

5. Back-up Light System

A: SCHEMATIC

1. BACK-UP LIGHT

<Ref. to WI-126, SCHEMATIC, Back-up Light System.>

B: INSPECTION

1. BACK-UP LIGHT SWITCH (MT MODEL)

Measure the back-up light switch resistance.

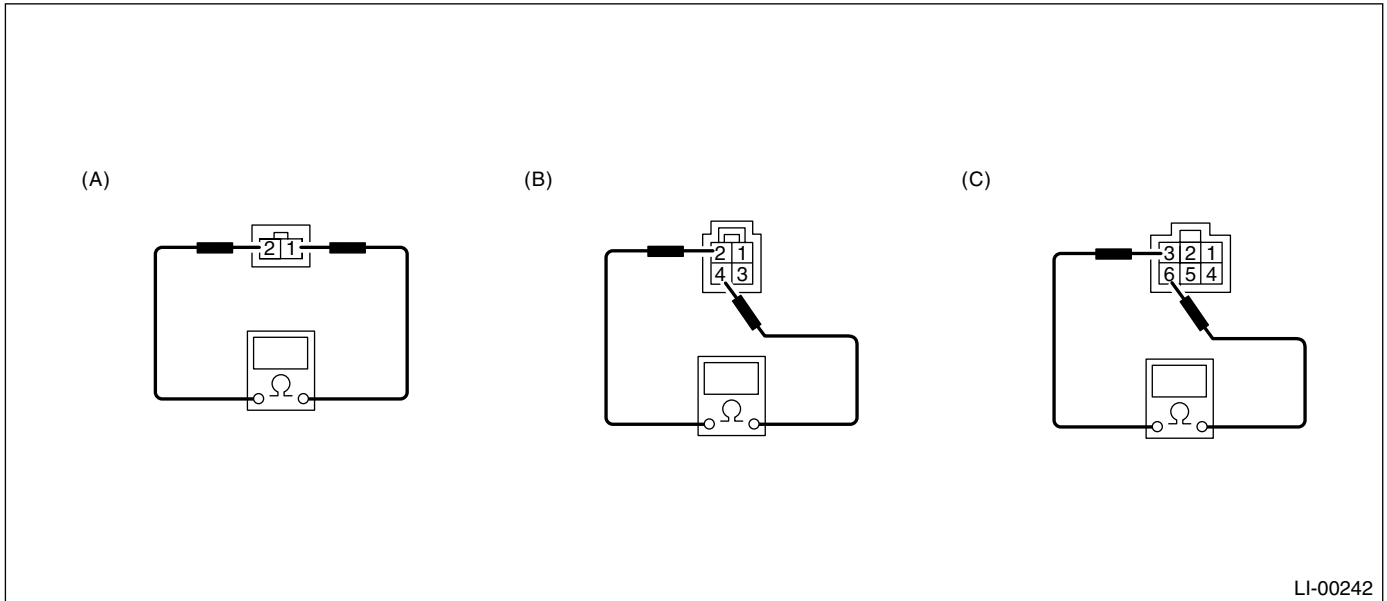

LI-00242

(A) Non-turbo model

(B) Turbo model (Except STi model)

(C) Turbo model (STi model)

Switch position	Terminal No.	Standard
When shift lever is set in reverse position	Turbo model (Except STi model): 2 and 4	Less than 1 Ω
Other positions	Turbo model (STi model): 3 and 6 Non-turbo model: 1 and 2	More than 1 MΩ

2. INHIBITOR SWITCH (AT MODEL)

Measure the inhibitor switch resistance.

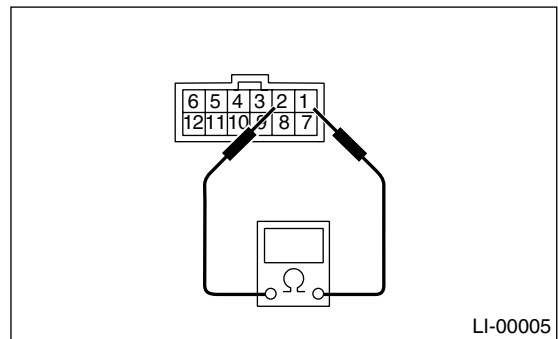

LI-00005

Switch position	Terminal No.	Standard
When select lever is set in "R" range	1 and 2	Less than 1 Ω
Other positions		More than 1 MΩ

6. Stop Light System

A: SCHEMATIC

1. STOP LIGHT

<Ref. to WI-141, SCHEMATIC, Stop Light System.>

B: INSPECTION

1. STOP LIGHT SWITCH

Measure the stop light switch resistance.

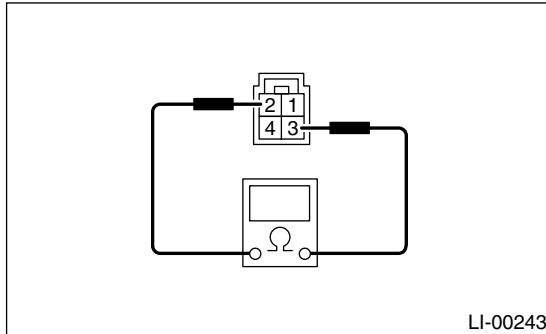

Switch position	Terminal No.	Standard
When brake pedal is depressed	2 and 3	Less than 1 Ω
When brake pedal is released		More than 1 MΩ

Brought to you by Eris Studios
NOT FOR RESALE

7. Interior Light System

A: SCHEMATIC

1. INTERIOR LIGHT

<Ref. to WI-139, SCHEMATIC, In Compartment Light System.>

B: INSPECTION

1. DOOR SWITCH

Measure the door switch resistance.

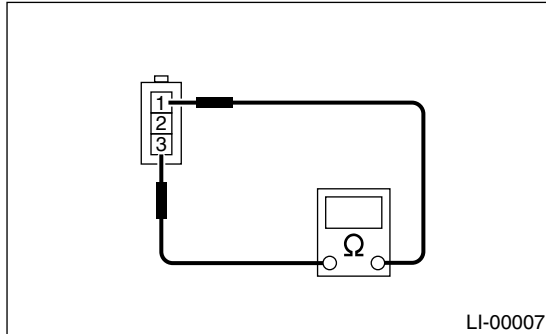

Switch position	Terminal No.	Standard
When door is opened	1 and 3	Less than 1 Ω
When door is closed		More than 1 MΩ

2. REAR GATE LATCH SWITCH

Measure the rear gate latch switch resistance.

Switch position	Terminal No.	Standard
When rear gate is opened	1 and 2	Less than 1 Ω
When rear gate is closed		More than 1 MΩ

3. TRUNK ROOM LIGHT SWITCH

Measure the trunk room light switch resistance.

Switch position	Terminal No.	Standard
When trunk lid is opened	1 and 2	Less than 1 Ω
When trunk lid is closed		More than 1 MΩ

8. Combination Switch (Light)

A: REMOVAL

- 1) Disconnect the ground cable from battery.
- 2) Remove the instrument panel lower cover. <Ref. to EI-44, REMOVAL, Instrument Panel Assembly.>
- 3) Remove the screws which secure the upper column cover to lower column cover.

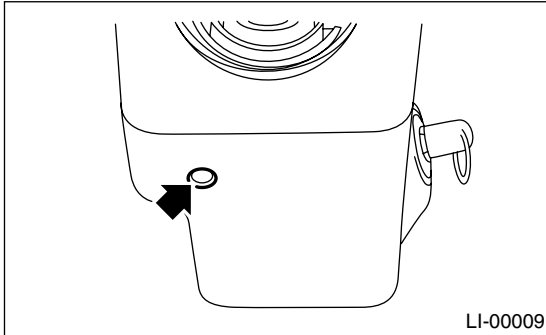

- 4) Disconnect the connector from combination switch.
- 5) Remove the screws which secure the switch, and then remove the switch.

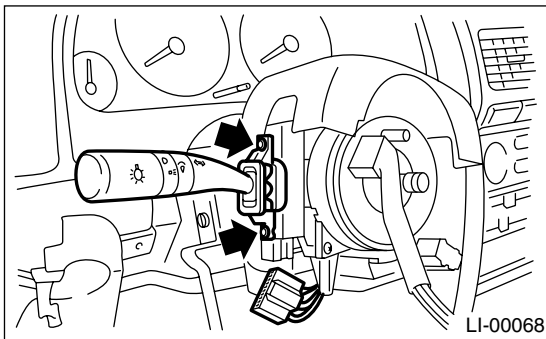

B: INSTALLATION

Install in the reverse order of removal.

C: INSPECTION

Measure the combination switch resistance.

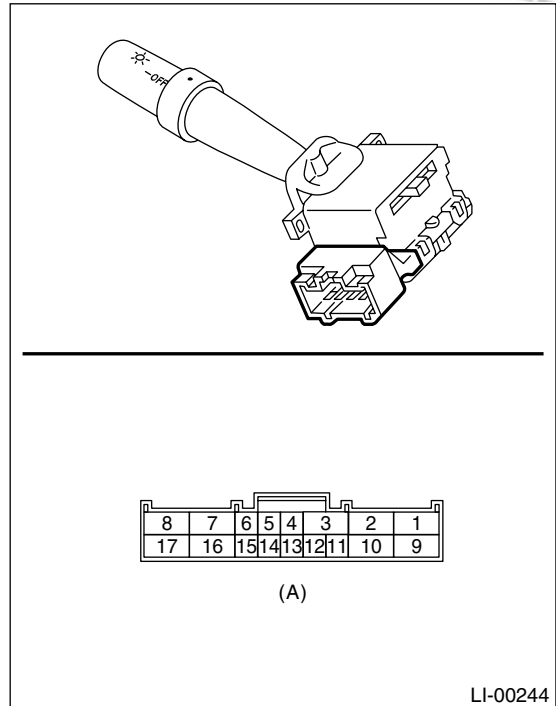

(A) Lighting and turn signal switch connector

1. LIGHTING SWITCH

Switch position	Terminal No.	Standard
OFF	—	More than 1 MΩ
Tail	14 and 16	Less than 1 Ω
Head	13, 14 and 16	Less than 1 Ω

2. DIMMER AND PASSING SWITCH

Switch position	Terminal No.	Standard
Passing	7, 8 and 16	Less than 1 Ω
Low beam	16 and 17	Less than 1 Ω
High beam	7 and 16	Less than 1 Ω

3. TURN SIGNAL SWITCH

Switch position	Terminal No.	Standard
Left	1 and 2	Less than 1 Ω
Neutral	—	More than 1 MΩ
Right	2 and 3	Less than 1 Ω

HEADLIGHT BEAM LEVELER SYSTEM

LIGHTING SYSTEM

9. Headlight Beam Leveler System

A: SCHEMATIC

1. HEADLIGHT BEAM LEVELER

<Ref. to WI-121, SCHEMATIC, Headlight Beam Leveler System.>

B: INSPECTION

1. HEADLIGHT BEAM LEVELER ACTUATOR

- 1) Turn on the headlights.
- 2) Confirm the headlight beam level is lowered by changing the switch position to 0 - 1 - 2 - 3.

2. HEADLIGHT BEAM LEVELER SWITCH

Connect the battery, headlight beam leveler switch connector and circuit tester as shown in the figure. Measure the voltage at each switch position.

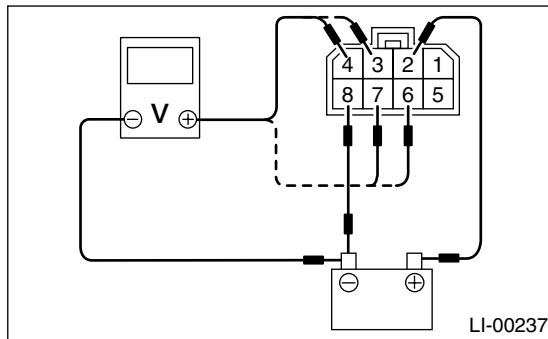

Switch position	Terminal No.	Standard
0	7 (+) and battery (-)	Battery voltage
1	6 (+) and battery (-)	Battery voltage
2	3 (+) and battery (-)	Battery voltage
3	4 (+) and battery (-)	Battery voltage

10. Combination Base Switch Assembly

A: REMOVAL

- 1) Remove the driver's airbag module. <Ref. to AB-12, REMOVAL, Driver's Airbag Module.>
- 2) Remove the steering wheel. <Ref. to PS-17, REMOVAL, Steering Wheel.>
- 3) Remove the steering column cover.
- 4) Remove the combination switch. <Ref. to LI-9, REMOVAL, Combination Switch (Light).> and <Ref. to WW-7, REMOVAL, Combination Switch (Wiper).>
- 5) Loosen the four screws and remove the roll connector.
- 6) Loosen the three screws.

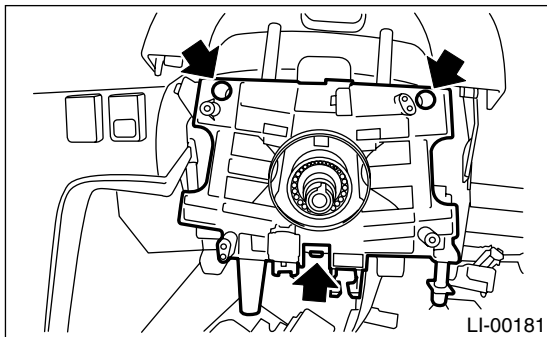

- 7) Disconnect the connector and remove the combination base switch assembly.

B: INSTALLATION

- 1) Install in the reverse order of removal.
- 2) Align the attaching direction of roll connector with the steering wheel, before installation of steering wheel. <Ref. to AB-18, ADJUSTMENT, Roll Connector.>

C: INSPECTION

1. COMBINATION BASE SWITCH ASSEMBLY

Perform the inspection for the following items and replace with a new one, if any damage is found.

- Crack or deformation of combination base switch assembly or roll connector

2. PARKING SWITCH

Measure the parking switch resistance.

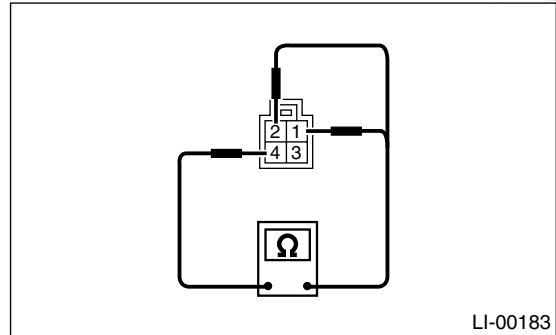

Switch position	Terminal No.	Standard
OFF	2 and 4	Less than 1 Ω
ON	1 and 4	Less than 1 Ω

11. Headlight Assembly

A: REMOVAL

- 1) Disconnect the ground cable from battery.
- 2) Remove the duct (A) (when right side headlight is removed).

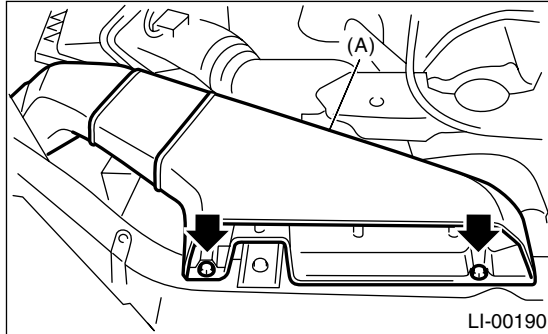

- 3) Remove the front grille and bumper upper clips. <Ref. to EI-19, REMOVAL, Front Grille.>
- 4) Disconnect each harness connector.
- 5) Remove the three bolts and disengage the clips, and then detach the headlight assembly.

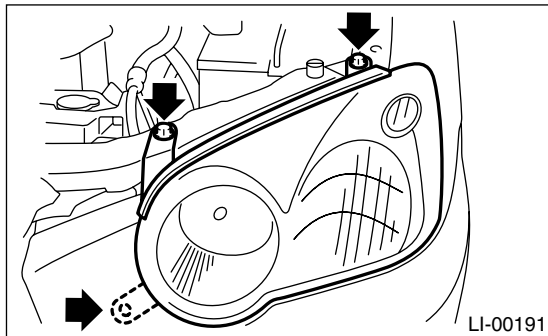

B: INSTALLATION

Install in the reverse order of removal.

C: ADJUSTMENT

1. HEADLIGHT AIMING

CAUTION:

Turn off the light before adjusting headlight aiming. If the light is necessary to check aiming, do not turn on for more than 2 minutes.

NOTE:

Before checking the headlight aiming, be sure of the following:

- The area around the headlight has not sustained any accident, damage or other type of deformation.
- Vehicle is parked on level ground.
- The inflation pressure of tires is correct.
- Vehicle's gas tank is fully charged.
- Bounce the vehicle several times to normalize the suspension.
- Make certain that someone is seated in the driver's seat.

Turn the headlights on and then adjust the low beam pattern to the following positions on the screen.

NOTE:

- Position the headlight beam leveler switch to "0".
- Rotate the adjusting screw (A) to adjust aim.

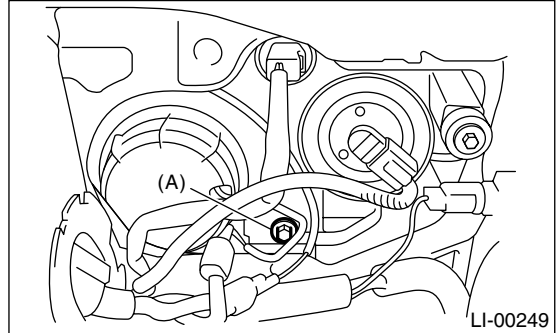

HEADLIGHT ASSEMBLY

LIGHTING SYSTEM

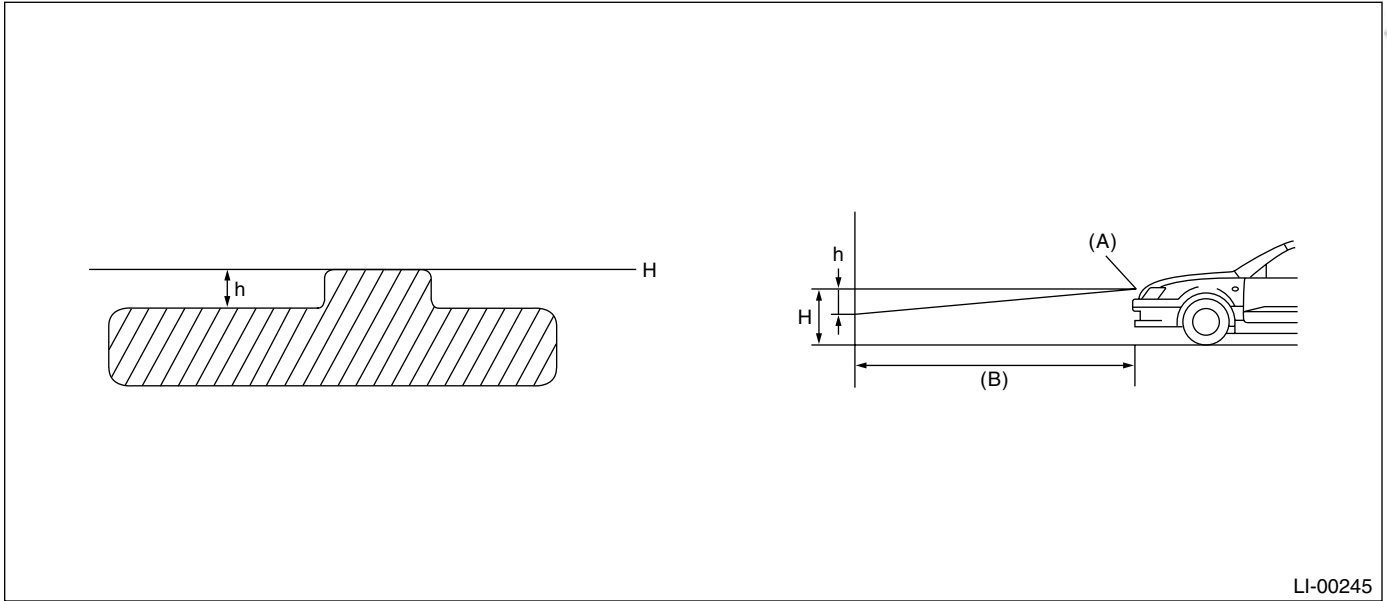

LI-00245

(A) Bulb center marking

(B) 3 m (10 ft)

H mm (in)				h mm (in) at 3 m (10 ft)
Sedan		Wagon		
STi	RS, WRX	TS, WRX	OUTBACK	
629 (24.76)	639 (25.16)	639 (25.16)	649 (25.55)	21 (0.83)

12. Headlight Bulb

A: REMOVAL

1. HIGH BEAM AND HALOGEN TYPE LOW BEAM

CAUTION:

- Because the tungsten halogen bulb operates at a high temperature, dirt and oil on the bulb surface reduces the bulb's service life. Hold the flange portion when replacing the bulb. Never touch the glass portion.
- Do not leave the headlight without a bulb for a long time. Dust, moisture, etc. entering the headlight may affect its performance.

- 1) Disconnect the ground cable from battery.
- 2) Remove the air intake duct (A) (when right side headlight bulb is removed).

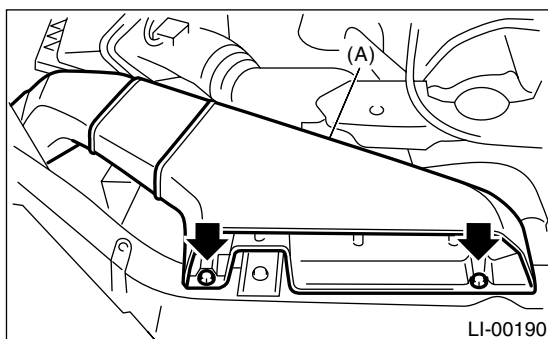

- 3) Disconnect the harness connector.
- 4) Remove the bulb ASSY (A): high beam. To remove the low beam, remove the back cover (B), and then go to Step 5.

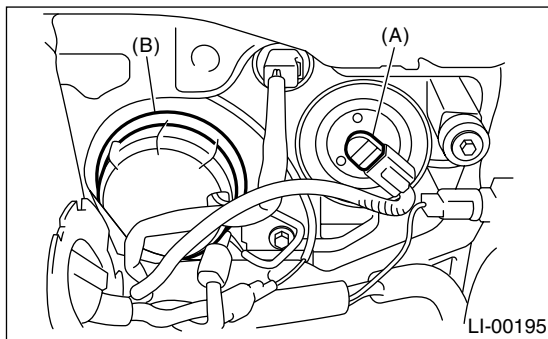

- 5) Remove the light bulb retaining spring (A) to remove the bulb.

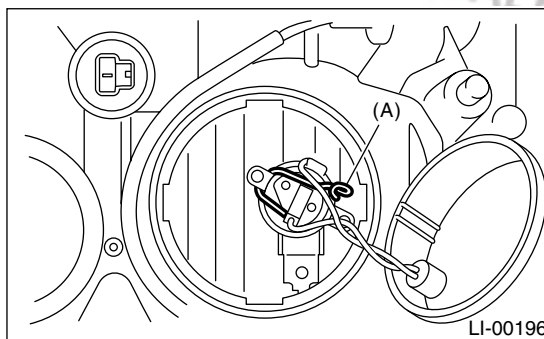

2. HID TYPE LOW BEAM

CAUTION:

- Do not operate with wet hands.
- As the lightening circuit uses high voltage, be sure to confirm that the power supply is turned off before operation.
- When replacing the bulb, hold the flange portion and never touch the glass portion.
- Do not leave the headlight without a bulb for a long time. Dust, and moisture, etc. entering the headlight may affect its performance.

- 1) Remove the ground cable from battery.
- 2) Remove the headlight assembly. <Ref. to LI-14, HID TYPE LOW BEAM, REMOVAL, Headlight Bulb.>
- 3) Remove the back cover.

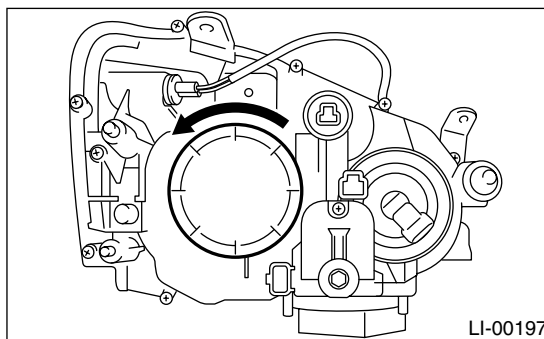

- 4) Disconnect the harness connector.

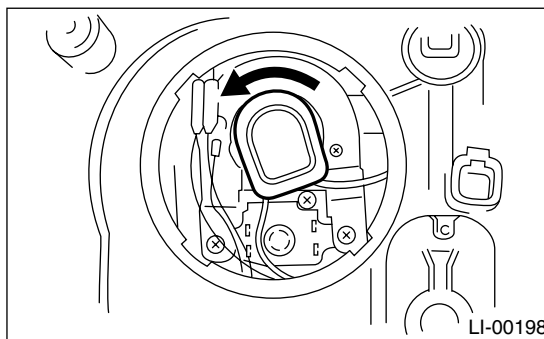

5) Remove the light bulb retaining spring, and then remove the bulb.

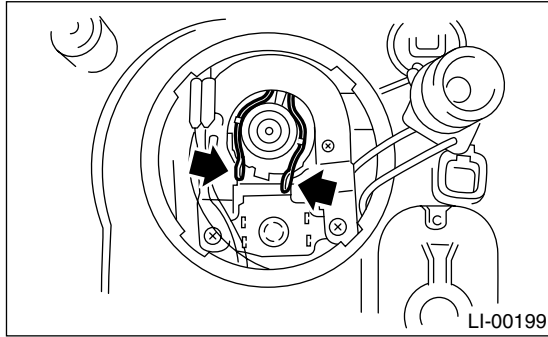

B: INSTALLATION

Install in the reverse order of removal.

CAUTION:

Attach the rubber cap with letters TOP on the top so the drain hole will be on the lower side.

C: INSPECTION

1. HALOGEN TYPE

- 1) Visually check the bulb for blow out.
- 2) Check the bulb specification. <Ref. to LI-2, SPECIFICATIONS, General Description.>
- 3) If NG, replace the bulb with a new one.

2. HID TYPE

CAUTION:

- Do not operate with wet hands.
- Do not touch the harness, inner headlight, or any metallic portion of the headlight when the light is illuminated (when the lighting switch is turned on).
- When performing a lighting test, make sure that the headlight is mounted on the vehicle, and the power supply is connected to the connector on the vehicle's side.

- 1) Check the bulb specification. <Ref. to LI-2, SPECIFICATIONS, General Description.>
- 2) Use a normal HID bulb for headlight lighting test.
- 3) If the headlight does not illuminate, replace the bulb with a new one. <Ref. to LI-15, DISPOSAL, Headlight Bulb.>

D: DISPOSAL

1. HID TYPE

CAUTION:

HID type light bulb contains mercury. Dispose the bulb according to regional regulation and contact SOA Service Center.

FRONT TURN SIGNAL LIGHT BULB

LIGHTING SYSTEM

13. Front Turn Signal Light Bulb

A: REMOVAL

1) Disconnect the harness connector (A), and then turn the socket (B) and remove the bulb.

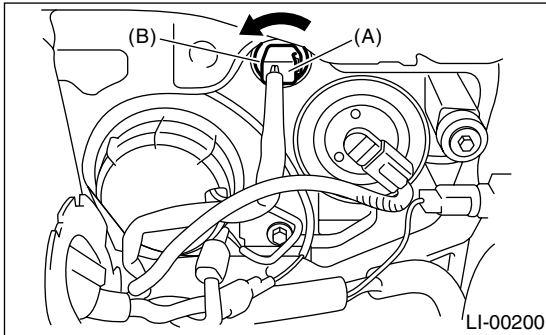

B: INSTALLATION

Install in the reverse order of removal.

C: INSPECTION

- 1) Visually check the bulb for blow out.
- 2) Check the bulb specification. <Ref. to LI-2, SPECIFICATIONS, General Description.>
- 3) If NG, replace the bulb with a new one.

14. Clearance/Parking/Front Side Marker Light Bulb

A: REMOVAL

- 1) Remove the headlight assembly. <Ref. to LI-12, REMOVAL, Headlight Assembly.>
- 2) Turn the socket (A) and remove the bulb.

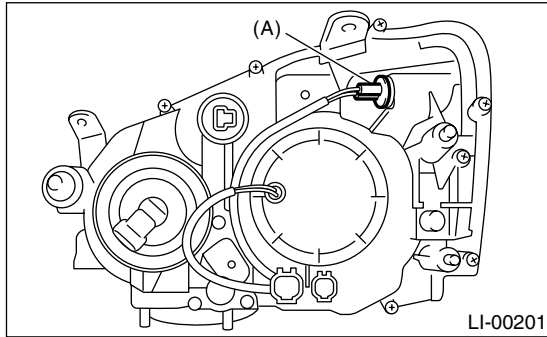

B: INSTALLATION

Install in the reverse order of removal.

C: INSPECTION

- 1) Visually check the bulb for blow out.
- 2) Check the bulb specification. <Ref. to LI-2, SPECIFICATIONS, General Description.>
- 3) If NG, replace the bulb with a new one.

15. Front Fog Light Assembly

A: REMOVAL

- 1) Disconnect the ground cable from battery.
- 2) Disengage two clips, and then turn over the lower mud guard.

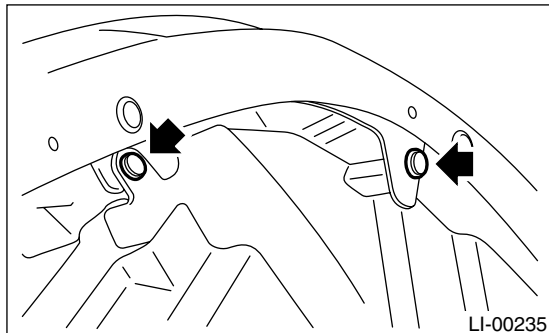

- 3) Disconnect the harness connector.
- 4) Remove the mounting bolts, and then remove the fog light assembly.

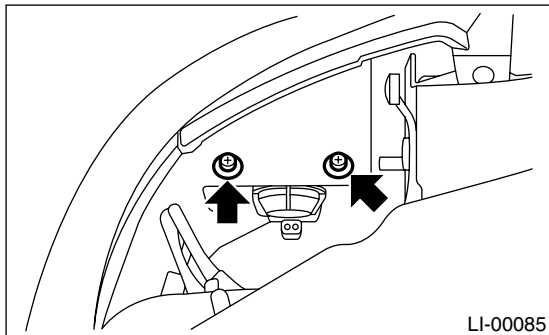

B: INSTALLATION

Install in the reverse order of removal.

16. Front Fog Light Bulb

A: REMOVAL

- 1) Disconnect the ground cable from battery.
- 2) Remove two clips, and then turn over the lower mud guard.

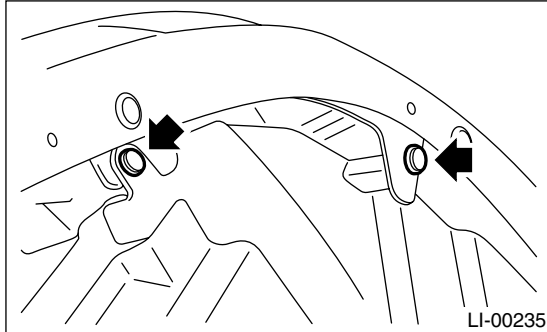

- 3) Remove the harness connector.
- 4) Remove the back cover (A).

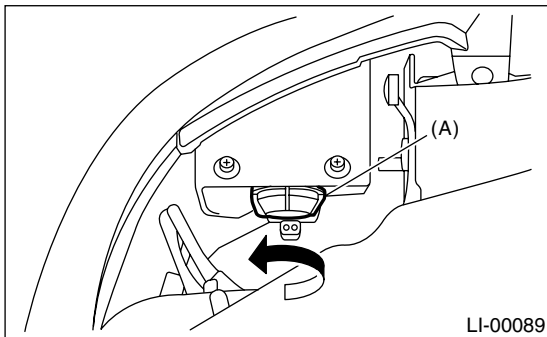

- 5) Remove the spring retainer, and then detach the fog light bulb.

B: INSTALLATION

Install in the reverse order of removal.

C: INSPECTION

- 1) Visually check the bulb for blow out.
- 2) Check the bulb specification. <Ref. to LI-2, SPECIFICATIONS, General Description.>
- 3) If NG, replace the bulb with a new one.

REAR COMBINATION LIGHT ASSEMBLY

LIGHTING SYSTEM

17. Rear Combination Light Assembly

A: REMOVAL

1. SEDAN

- 1) Disconnect the ground cable from battery.
- 2) Remove the clips, and then detach the trunk rear trim.

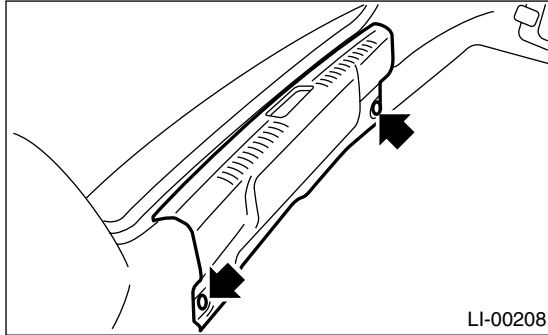

- 3) Remove the trunk side trim of rear portion.
- 4) Remove the four nuts, and then detach the rear combination light while disconnecting connector.

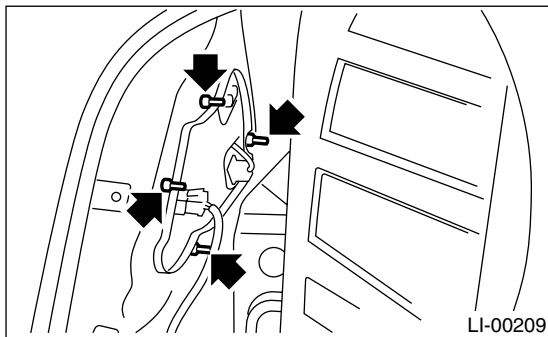

2. WAGON

- 1) Disconnect the ground cable from battery.
- 2) Remove the clips, and then detach the rear combination light covers.

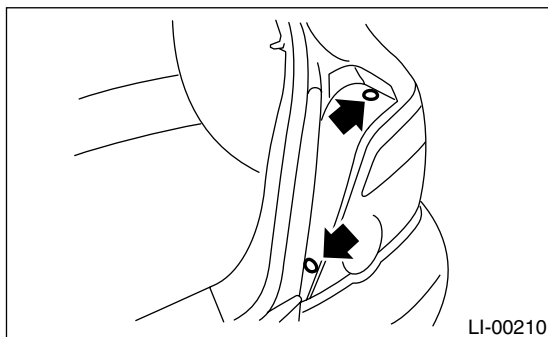

- 3) Remove two bolts, and then remove the rear combination light while disconnecting connector.

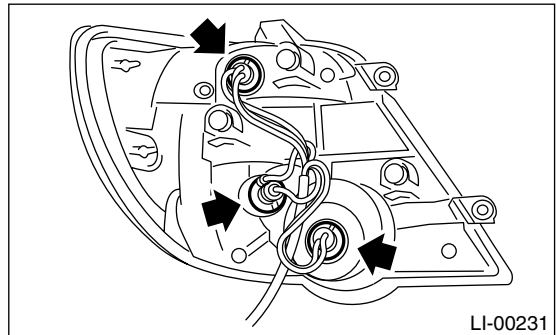
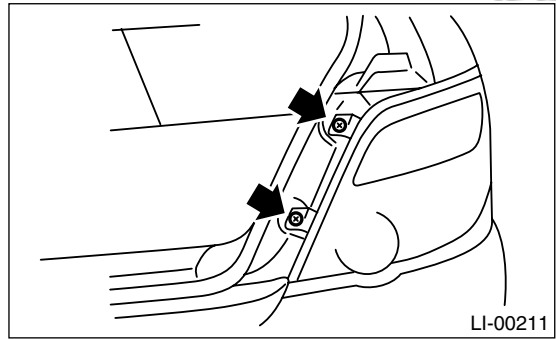

B: INSTALLATION

Install in the reverse order of removal.

18. Tail/Rear Side Marker/Stop Light Bulb

A: REMOVAL

1. SEDAN

- 1) Remove the trunk side trim of rear portion.
- 2) Turn the socket and remove the bulb.

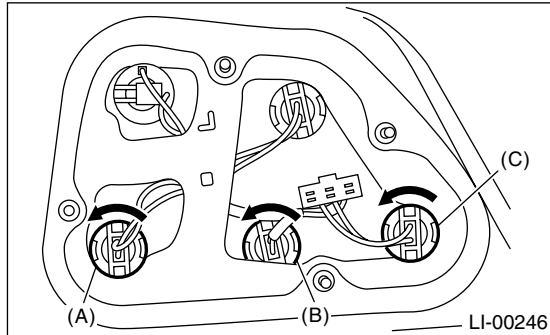

- (A) Stop/tail light
- (B) Tail light
- (C) Stop light

2. WAGON

- 1) Remove the rear combination light assembly. <Ref. to LI-20, WAGON, REMOVAL, Rear Combination Light Assembly.>
- 2) Turn the socket and remove the bulb.

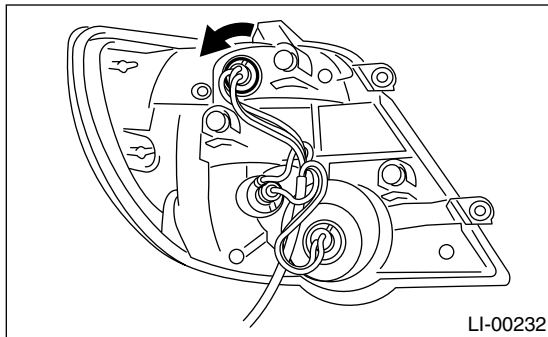

B: INSTALLATION

Install in the reverse order of removal.

C: INSPECTION

- 1) Visually check the bulb for blow out.
- 2) Check the bulb specification. <Ref. to LI-2, SPECIFICATIONS, General Description.>
- 3) If NG, replace the bulb with a new one.

Brought to you by Eris Studios
NOT FOR RESALE

19. Back-up Light Bulb

A: REMOVAL

1. SEDAN

- 1) Remove the trunk side trim of rear portion.
- 2) Turn the socket and remove the bulb.

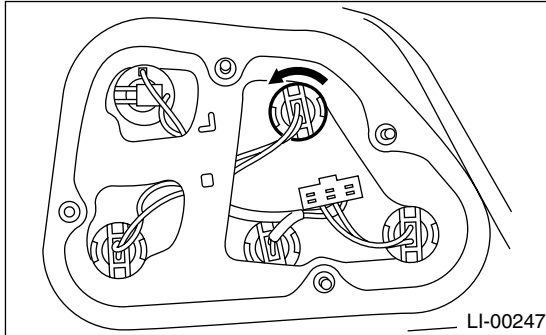

2. WAGON

- 1) Remove the rear combination light assembly. <Ref. to LI-20, WAGON, REMOVAL, Rear Combination Light Assembly.>
- 2) Turn the socket and remove the bulb.

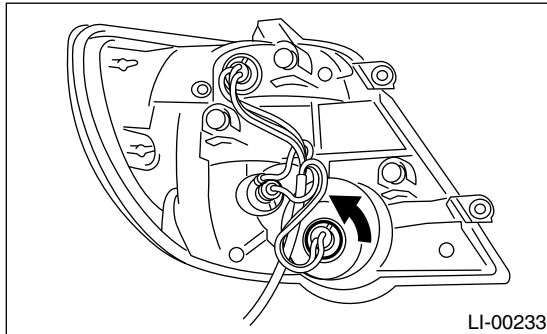

B: INSTALLATION

Install in the reverse order of removal.

C: INSPECTION

- 1) Visually check the bulb for blow out.
- 2) Check the bulb specification. <Ref. to LI-2, SPECIFICATIONS, General Description.>
- 3) If NG, replace the bulb with a new one.

20. Rear Turn Signal Light Bulb

A: REMOVAL

1. SEDAN

- 1) Remove the trunk side trim of rear portion.
- 2) Turn the socket and remove the bulb.

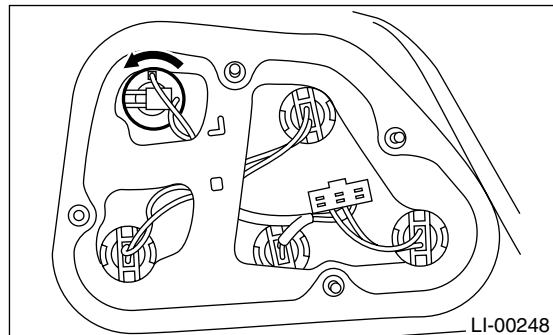

2. WAGON

- 1) Remove the rear combination light assembly. <Ref. to LI-20, WAGON, REMOVAL, Rear Combination Light Assembly.>
- 2) Turn the socket and remove the bulb.

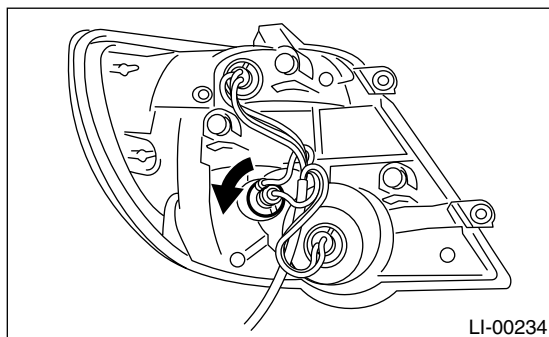

B: INSTALLATION

Install in the reverse order of removal.

C: INSPECTION

- 1) Visually check the bulb for blow out.
- 2) Check the bulb specification. <Ref. to LI-2, SPECIFICATIONS, General Description.>
- 3) If NG, replace the bulb with a new one.

Brought to you by Eris Studios
NOT FOR RESALE

21. License Plate Light

A: REMOVAL

- 1) Remove the license plate light mounting screw (A), and then remove the lens (B).

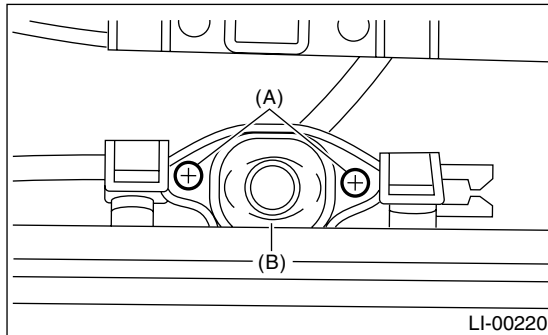

- 2) Remove the bulb.

B: INSTALLATION

Install in the reverse order of removal.

C: INSPECTION

- 1) Visually check the bulb for blow out.
- 2) Check the bulb specification. <Ref. to LI-2, SPECIFICATIONS, General Description.>
- 3) If NG, replace the bulb with a new one.

22.High-mounted Stop Light

A: REMOVAL

1. SEDAN (STANDARD TYPE)

- 1) Disconnect the ground cable from battery.
- 2) Disconnect the connector of high-mounted stop light from body harness.
- 3) Remove the bolts, then detach the high-mounted stop light assembly.

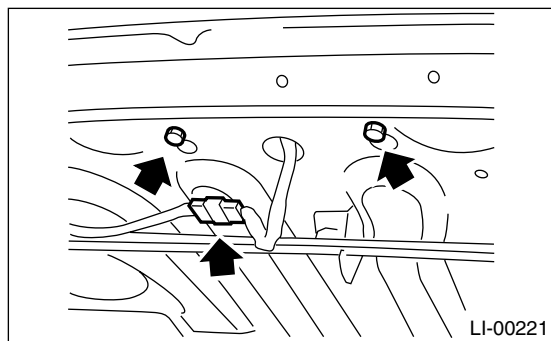

2. SEDAN (REAR SPOILER BUILT-IN TYPE)

- 1) Disconnect the ground cable from battery.
- 2) Remove the bolts, then detach the high-mounted stop light assembly.
- 3) Disconnect the connector of high-mounted stop light from body harness.

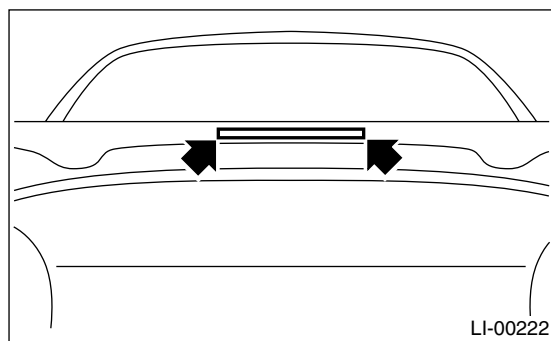

3. WAGON

- 1) Disconnect the ground cable from battery.
- 2) Remove the cap (a) by prying on the edge with screwdriver.
- 3) Remove the screws (b), and then the detach cover (c).

- 4) Remove screws (d), and then detach the high-mounted stop light while disconnecting connector.

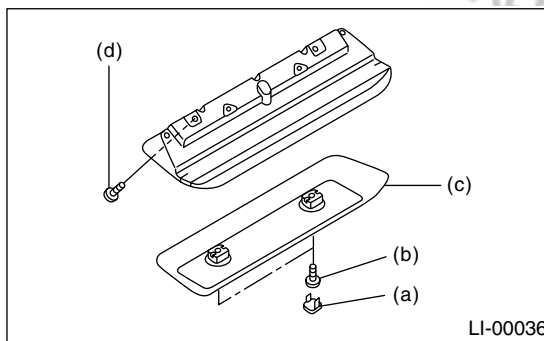

B: INSTALLATION

Install in the reverse order of removal.

C: INSPECTION

- 1) Visually check the bulb for blow out.
- 2) Check the bulb specification. <Ref. to LI-2, SPECIFICATIONS, General Description.>
- 3) If NG, replace the bulb with a new one.

Brought to you by Eris Studios
NOT FOR RESALE

23. Spot Map Light

A: REMOVAL

- 1) Disconnect the ground cable from battery.
- 2) Remove the lens (A) and spot map light mounting screw (B).

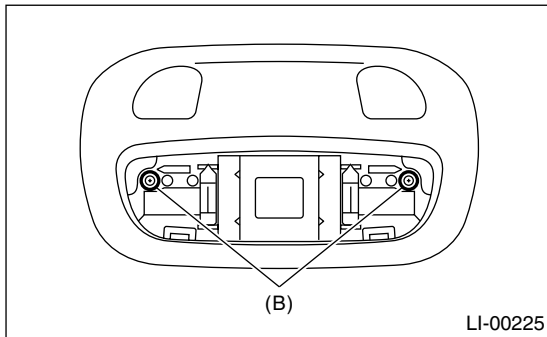
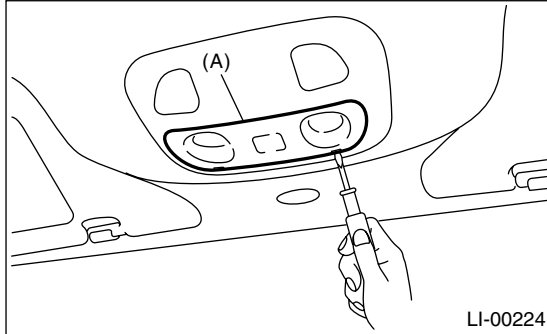

- 3) Disconnect the harness connectors and remove the spot map light.

B: INSTALLATION

Install in the reverse order of removal.

C: INSPECTION

1. SPOT MAP LIGHT BULB

- 1) Visually check the bulb for blow out.
- 2) Check the bulb specification. <Ref. to LI-2, SPECIFICATIONS, General Description.>
- 3) If NG, replace the bulb with a new one.

2. SPOT MAP LIGHT SWITCH

Measure the spot map light resistance.

Switch position	Terminal No.	Standard
OFF	—	More than 1 MΩ
ON	1 and 2	18±5.4 Ω

Brought to you by Eris Studios
NOT FOR RESALE

24. Room Light

A: REMOVAL

- 1) Disconnect the ground cable from battery.
- 2) Remove the lens (A) and room light mounting screws (B).

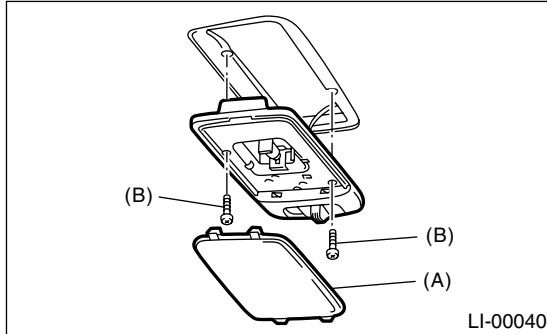

- 3) Disconnect the harness connectors and remove the light.

B: INSTALLATION

Install in the reverse order of removal.

C: INSPECTION

1. ROOM LIGHT BULB

- 1) Visually check the bulb for blow out.
- 2) Check the bulb specification. <Ref. to LI-2, SPECIFICATIONS, General Description.>
- 3) If NG, replace the bulb with a new one.

2. ROOM LIGHT SWITCH

Measure the room light resistance.

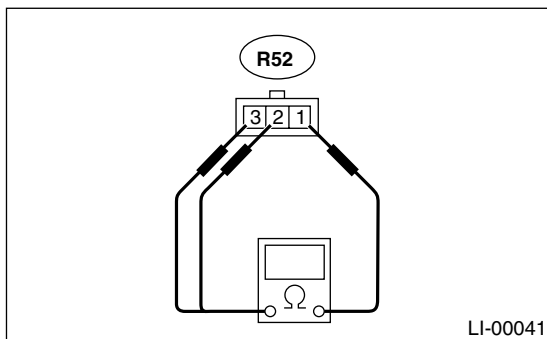

Switch position	Terminal No.	Standard
OFF	—	More than 1 MΩ
ON	1 and 3	1.5±0.5 Ω
DOOR	1 and 2	1.5±0.5 Ω

25. Luggage Room Light

A: REMOVAL

- 1) Disconnect the ground cable from battery.
- 2) Remove the lens (A) and luggage room light mounting screws (B).

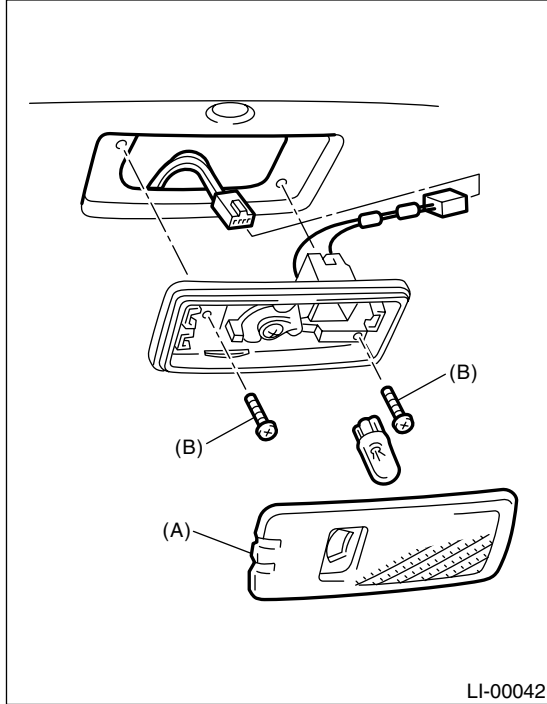

- 3) Disconnect the harness connectors and remove the luggage room light.

B: INSTALLATION

Install in the reverse order of removal.

C: INSPECTION

1. LUGGAGE ROOM LIGHT BULB

- 1) Visually check the bulb for blow out.
- 2) Check the bulb specification. <Ref. to LI-2, SPECIFICATIONS, General Description.>
- 3) If NG, replace the bulb with a new one.

2. LUGGAGE ROOM LIGHT SWITCH

Measure the luggage room light resistance.

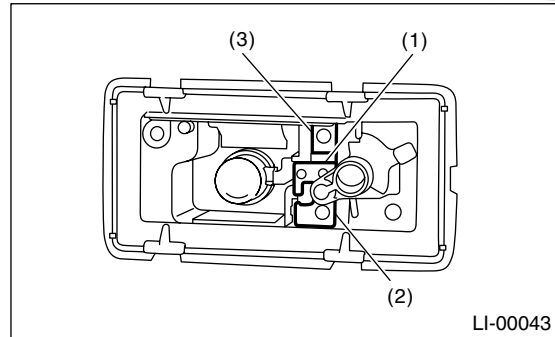

Switch position	Terminal No.	Standard
OFF	—	More than 1 MΩ
ON	1 and 3	1.5±0.5 Ω
DOOR	1 and 2	1.5±0.5 Ω

26. Trunk Room Light

A: REMOVAL

- 1) Disconnect the ground cable from battery.
- 2) Disconnect the harness connectors and remove the trunk room light.

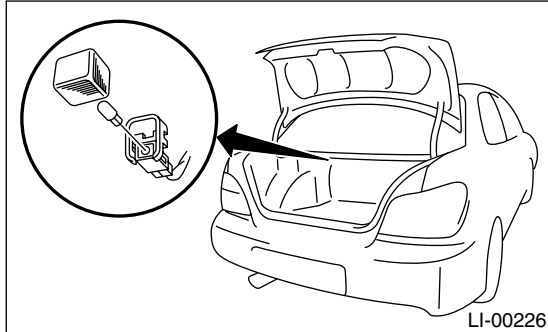

B: INSTALLATION

Install in the reverse order of removal.

C: INSPECTION

- 1) Visually check the bulb for blow out.
- 2) Check the bulb specification. <Ref. to LI-2, SPECIFICATIONS, General Description.>
- 3) If NG, replace the bulb with a new one.

27. Glove Box Light

A: REMOVAL

- 1) Disconnect the ground cable from battery.
- 2) Remove the glove box. <Ref. to EI-40, REMOVAL, Glove Box.>
- 3) Disconnect the harness connector.
- 4) Remove the glove box light.

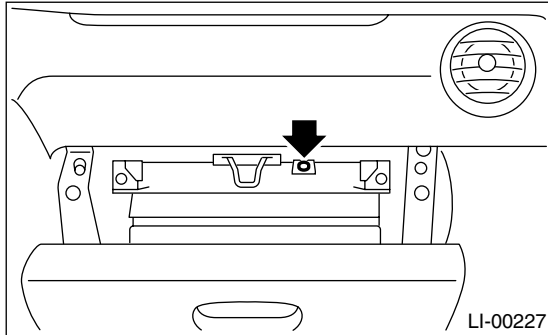

B: INSTALLATION

Install in the reverse order of removal.

C: INSPECTION

- 1) Visually check the bulb for blow out.
- 2) Check the bulb specification. <Ref. to LI-2, SPECIFICATIONS, General Description.>
- 3) If NG, replace the bulb with a new one.