

Brought to you by Eris Studios
NOT FOR RESALE

SECURITY AND LOCKS

GENERAL DESCRIPTION

SECURITY AND LOCKS

1. General Description

A: COMPONENT

1. DOOR LOCK ASSEMBLY

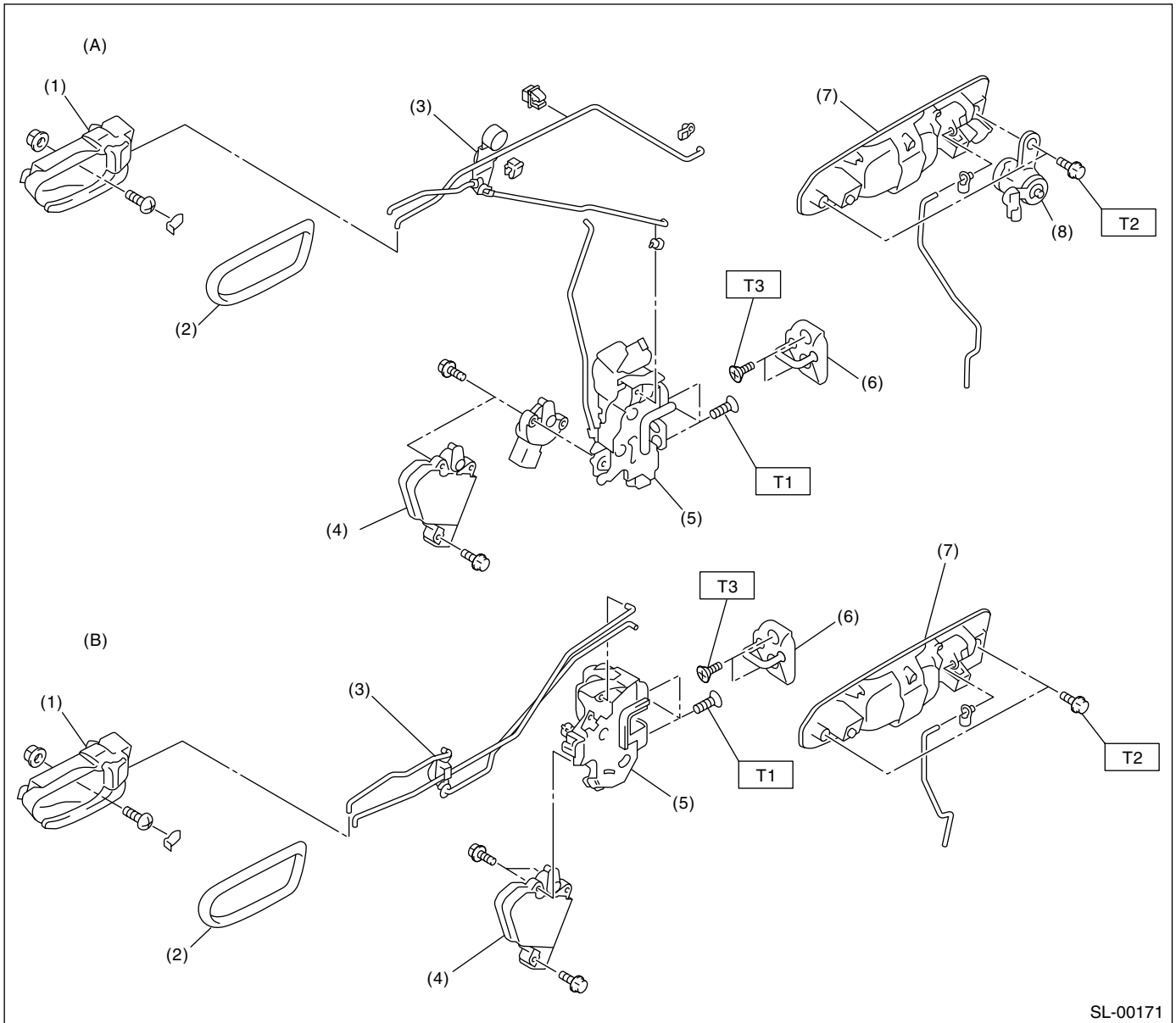

SL-00171

(A) Front

(B) Rear

- (1) Inner remote ASSY
- (2) Inner remote cover
- (3) Bell crank
- (4) Auto-door lock actuator

- (5) Door latch
- (6) Striker
- (7) Door outer handle
- (8) Key cylinder

Tightening torque: N-m (kgf-m, ft-lb)

T1: 6.4 (0.65, 4.7)

T2: 7.4 (0.75, 5.5)

T3: 17.6 (1.8, 13.0)

GENERAL DESCRIPTION

SECURITY AND LOCKS

2. TRUNK LID AND REAR GATE LOCK

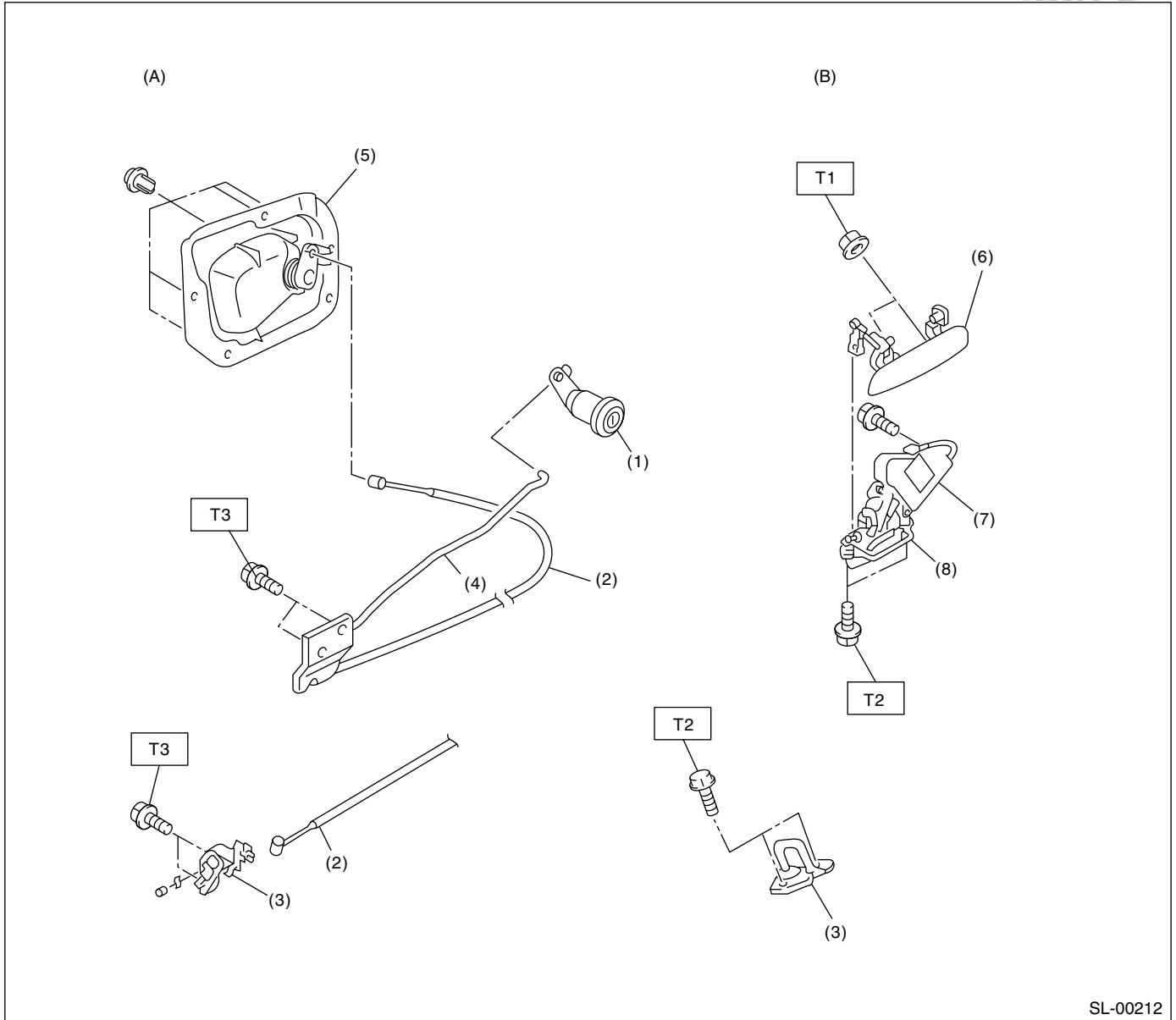

(A) Trunk

(B) Rear gate

- (1) Key cylinder
- (2) Cable
- (3) Striker
- (4) Trunk lid lock ASSY

- (5) Trunk lid release handle
- (6) Rear gate outer handle
- (7) Rear gate actuator
- (8) Rear gate latch

Tightening torque: N·m (kgf·m, ft·lb)

T1: 4.5 (0.45, 3.3)

T2: 25 (2.5, 18.4)

T3: 18 (1.84, 13.3)

GENERAL DESCRIPTION

SECURITY AND LOCKS

3. HOOD LOCK AND REMOTE OPENERS

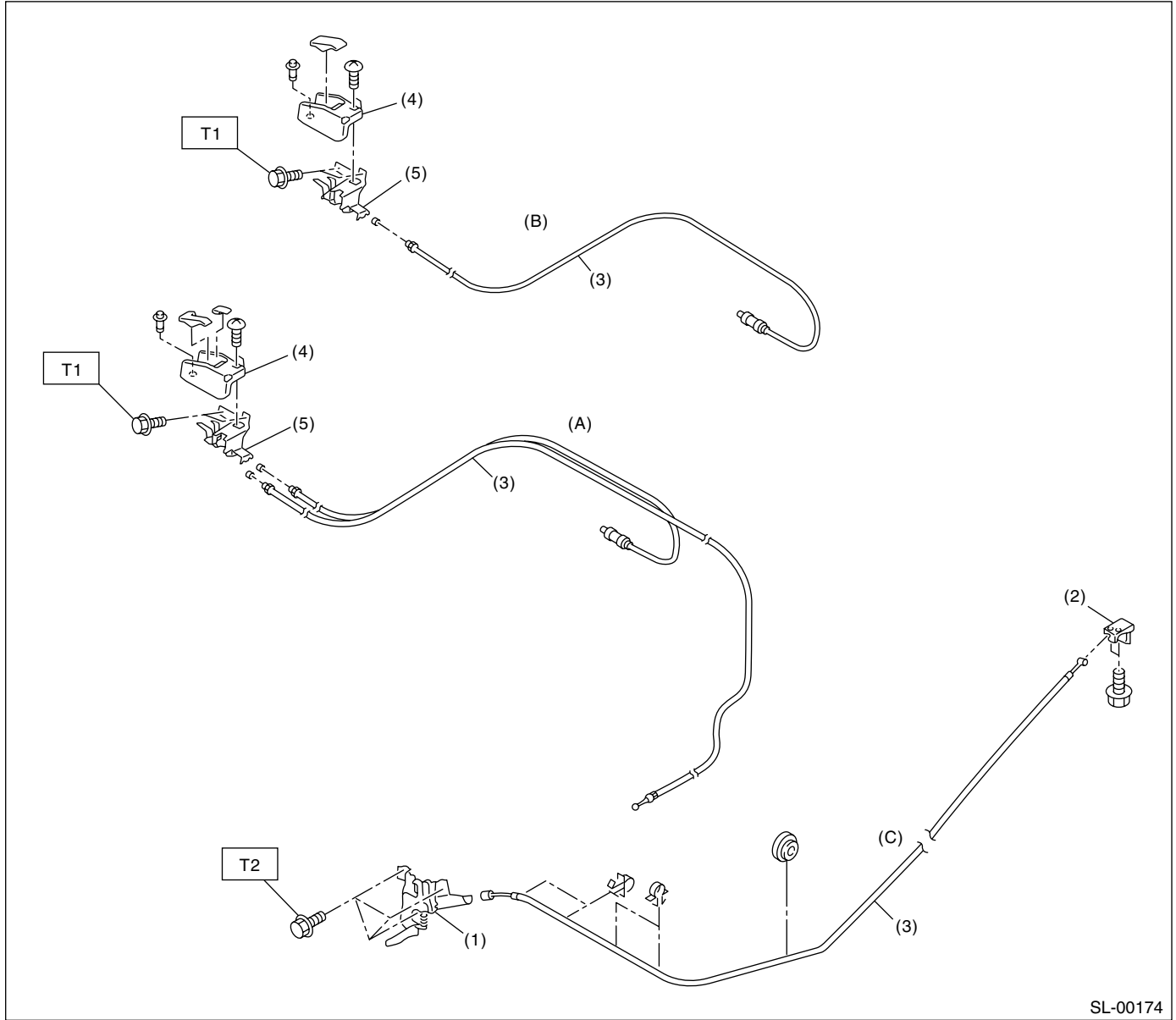

(A) Sedan

(B) Wagon

(C) Hood

(1) Hood lock ASSY

(4) Cover

Tightening torque: N-m (kgf-m, ft-lb)

(2) Lever ASSY

(5) Pull handle ASSY

T1: 6.4 (0.65, 4.7)

(3) Cable

T2: 32 (3.3, 23.9)

4. KEYLESS ENTRY SYSTEM

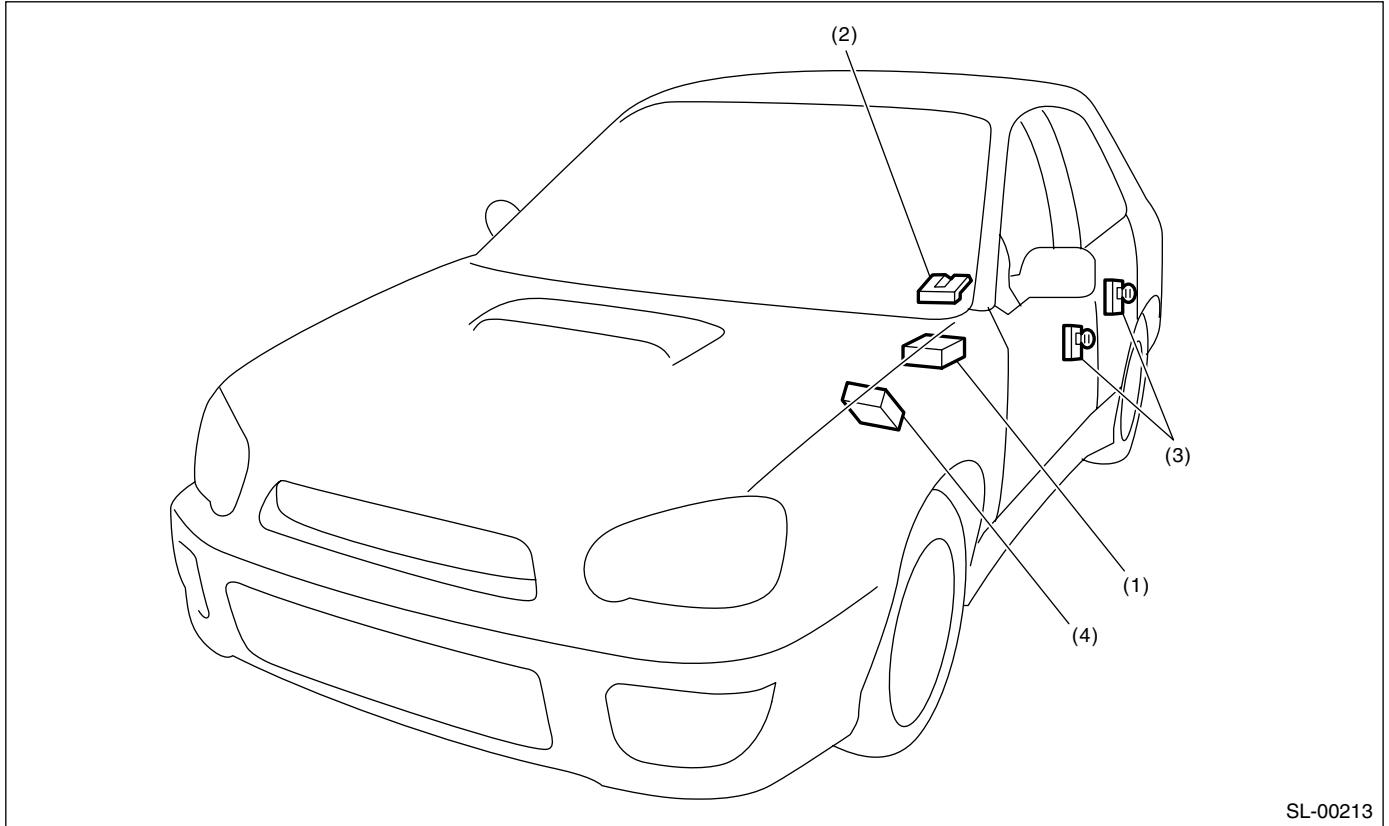

SL-00213

- (1) Keyless entry control module
- (2) Rear gate latch (Wagon model)

- (3) Door switch

- (4) Body integrated module

5. SECURITY SYSTEM

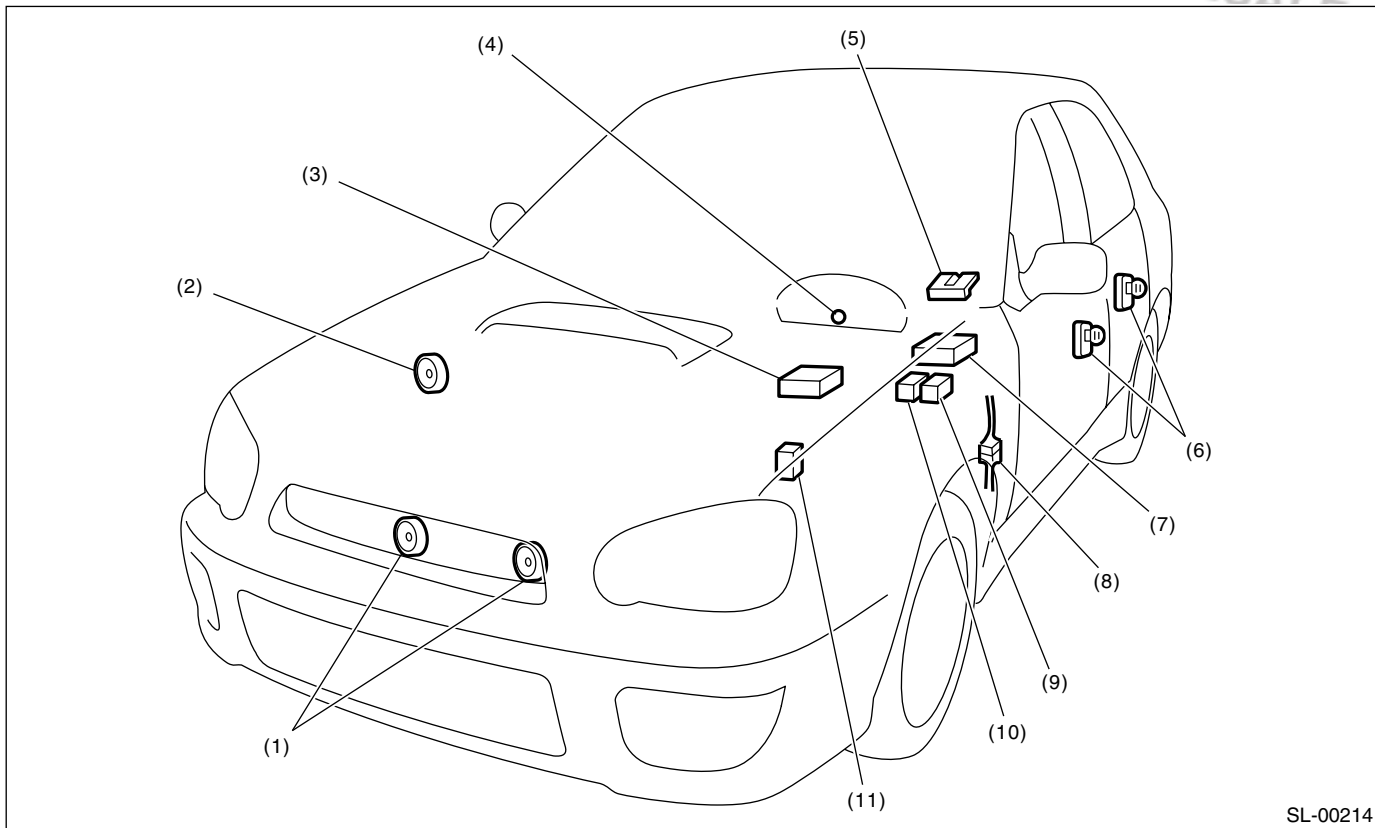

SL-00214

- | | | |
|---|---|---------------------------|
| (1) Horn | (5) Trunk room light switch (Sedan), rear gate latch switch (Wagon) | (8) Passive arm connector |
| (2) Security horn | (6) Door switch | (9) Security horn relay |
| (3) Security control module | (7) Keyless entry control module | (10) Interrupt relay |
| (4) Security indicator light (in combination meter) | (11) Horn relay (in main fuse box) | |

B: CAUTION

- Before disassembling or reassembling parts, always disconnect the ground cable from battery. When repairing radio, control module, etc. which are provided with memory functions, record the memory contents before disconnecting the ground cable from battery. Otherwise, these contents are cancelled upon disconnection.
- Reassemble parts in the reverse order of disassembly procedure unless otherwise indicated.

- Adjust parts to specifications contained in this manual if so designated.
- Connect the connectors and hoses securely during reassembly.
- After reassembly, ensure all functional parts operate smoothly.
- Airbag system wiring harness is routed near the electrical parts and switch.
- All airbag system wiring harness and connectors are colored yellow. Do not use electrical test equipment on these circuits.
- Be careful not to damage the airbag system wiring harness when servicing the ignition key cylinder.

C: PREPARATION TOOL

1. SPECIAL TOOLS

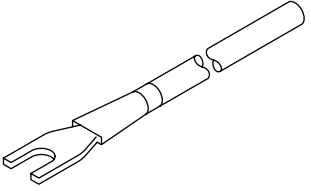
ILLUSTRATION	TOOL NUMBER	DESCRIPTION	REMARKS
 <p>ST-925580000</p>	925580000	PULLER	Used for removing trim clip

2. GENERAL TOOLS

TOOL NAME	REMARKS
Circuit Tester	Used for measuring resistance and voltage.
Drill	Used for replacing ignition key lock.

DOOR LOCK CONTROL SYSTEM

SECURITY AND LOCKS

2. Door Lock Control System

A: SCHEMATIC

1. DOOR LOCK CONTROL

<Ref. to WI-123, SCHEMATIC, Keyless Entry System.>

B: INSPECTION

1. SYMPTOM CHART

Symptom	Repair order	Reference
The door lock control system does not operate.	1. Check the fuse.	<Ref. to SL-8, CHECK FUSE, INSPECTION, Door Lock Control System.>
	2. Check the power supply and ground circuit for the body integrated module.	<Ref. to SL-9, CHECK POWER SUPPLY AND GROUND CIRCUIT, INSPECTION, Door Lock Control System.>
	3. Check the door lock switch and the circuit.	<Ref. to SL-9, CHECK DOOR LOCK SWITCH AND CIRCUIT, INSPECTION, Door Lock Control System.>
	4. Check the door lock actuator and the circuit.	<Ref. to SL-10, CHECK DOOR LOCK ACTUATOR AND CIRCUIT, INSPECTION, Door Lock Control System.>
The door lock switch does not operate.	Check the door lock switch and the circuit.	<Ref. to SL-9, CHECK DOOR LOCK SWITCH AND CIRCUIT, INSPECTION, Door Lock Control System.>
A specific door lock actuator does not operate.	Check the door lock actuator and the circuit.	<Ref. to SL-10, CHECK DOOR LOCK ACTUATOR AND CIRCUIT, INSPECTION, Door Lock Control System.>

2. CHECK FUSE

Step	Check	Yes	No
1 CHECK FUSE. Remove and visually check the fuse No. 2 (in the main fuse box).	In the fuse blown out?	Replace the fuse with a new one.	Check the power supply and ground circuit. <Ref. to SL-9, CHECK POWER SUPPLY AND GROUND CIRCUIT, INSPECTION, Door Lock Control System.>

DOOR LOCK CONTROL SYSTEM

3. CHECK POWER SUPPLY AND GROUND CIRCUIT

Step	Check	Yes	No	
1	CHECK POWER SUPPLY. 1) Disconnect the body integrated module harness connector. 2) Measure the voltage between the harness connector terminal and chassis ground. <i>Connector & terminal</i> <i>(B280) No. 1, 2 (+) — Chassis ground (-):</i>	Is the voltage more than 10 V?	Go to step 2.	Check the harness for open circuits or shorts between the body integrated module and the fuse.
2	CHECK GROUND CIRCUIT. Measure the resistance between the harness connector terminal and chassis ground. <i>Connector & terminal</i> <i>(B280) No. 4, 13 — Chassis ground:</i>	Is the resistance less than 10 Ω ?	The power supply and ground circuit is OK.	Repair the harness.

4. CHECK DOOR LOCK SWITCH AND CIRCUIT

Step	Check	Yes	No	
1	CHECK DOOR LOCK SWITCH CIRCUIT. 1) Disconnect the body integrated module harness connector. 2) Measure the resistance between the harness connector terminal and chassis ground when moving the door lock switch to LOCK. <i>Connector & terminal</i> <i>(B281) No. 12 — Chassis ground:</i>	Is the resistance less than 10 Ω ?	Go to step 2.	Go to step 3.
2	CHECK DOOR LOCK SWITCH CIRCUIT. Measure the resistance between the harness connector terminal and chassis ground when the door lock switch is moved to UNLOCK. <i>Connector & terminal</i> <i>(B281) No. 11 — Chassis ground:</i>	Is the resistance less than 10 Ω ?	The door lock switch is OK.	Go to step 3.
3	CHECK DOOR LOCK SWITCH. 1) Disconnect the door lock switch harness connector. 2) Measure the resistance between the door lock switch terminals when moving the door lock switch to LOCK. <i>Connector & terminal</i> <i>Driver's side:</i> <i>(D7) No. 5 — No. 9</i> <i>Passenger's side:</i> <i>(D62) No. 4 — No. 5</i>	Is the resistance less than 10 Ω ?	Go to step 4.	Replace the door lock switch.
4	CHECK DOOR LOCK SWITCH. Measure the resistance between the door lock switch terminals when moving the door lock switch to UNLOCK. <i>Connector & terminal</i> <i>Driver's side:</i> <i>(D7) No. 5 — No. 8</i> <i>Passenger's side:</i> <i>(D62) No. 2 — No. 5</i>	Is the resistance less than 1 Ω ?	Check the harness for open circuits or shorts between the body integrated module and the door lock switch.	Replace the door lock switch.

DOOR LOCK CONTROL SYSTEM

SECURITY AND LOCKS

5. CHECK DOOR LOCK ACTUATOR AND CIRCUIT

Step	Check	Yes	No
1 CHECK OUTPUT SIGNAL. Measure the voltage between the harness connector terminal of body integrated module and chassis ground when moving the door lock switch to LOCK. <i>Connector & terminal</i> <i>(B280) No. 6 (+) — Chassis ground (-):</i>	Is the voltage more than 10 V?	Go to step 2.	Replace the body integrated module.
2 CHECK OUTPUT SIGNAL. Measure the voltage between the harness connector terminal of body integrated module and chassis ground when moving the door lock switch to UNLOCK. <i>Connector & terminal</i> <i>(B280) No. 7 (+) — Chassis ground (-):</i>	Is the voltage more than 10 V?	Go to step 3.	Replace the body integrated module.
3 CHECK DOOR LOCK ACTUATOR. Check the door lock actuator. Front door lock actuator: <Ref. to SL-31, Front Door Lock Actuator.> Rear door lock actuator: <Ref. to SL-35, Rear Door Lock Actuator.> Rear gate latch lock actuator: <Ref. to SL-38, Rear Gate Latch Lock Actuator.>	Is the door lock actuator OK?	Check the harness for open circuits or shorts between the body integrated module and the door lock actuator.	Replace the door lock actuator.

Brought to you by Eris Studios
NOT FOR RESALE

3. Keyless Entry System

A: SCHEMATIC

1. KEYLESS ENTRY

<Ref. to WI-123, SCHEMATIC, Keyless Entry System.>

B: ELECTRICAL SPECIFICATION

1. KEYLESS ENTRY CONTROL MODULE

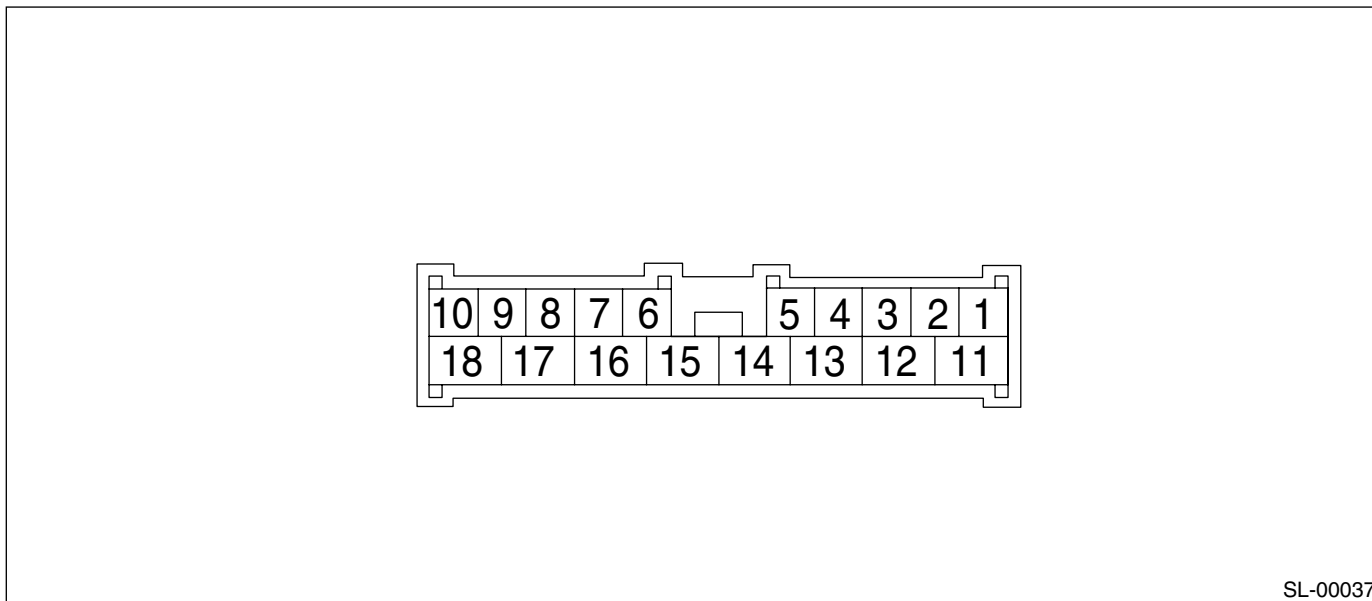

SL-00037

Content	Terminal No.	Measuring condition
Body integrated module	1 (OUTPUT)	Battery voltage is present when pressing the transmitter LOCK/ARM button.
Body integrated module	2 (OUTPUT)	Battery voltage is present when pressing the transmitter UNLOCK/DISARM button.
Security control module	3	—
Security control module	4	—
Door lock switch	5 (INPUT)	0 V is present when operating the door lock switch.
Ignition switch (ON)	6 (INPUT)	Battery voltage is present when ignition switch is turned to ON.
Key warning switch	7 (INPUT)	Battery voltage is present when inserting the key into the ignition switch.
Door unlock switch	8 (INPUT)	0 V is present when operating the door lock switch.
Rear gate latch switch	9 (INPUT)	0 V is present when rear gate is open.
Door switch	10 (INPUT)	0 V is present when any door is open.
Ground	11	0 V is constantly present.
Turn signal light (Left)	12 (OUTPUT)	Battery voltage is present when pressing the transmitter UNLOCK/DISARM or LOCK/ARM button.
Horn relay	13 (OUTPUT)	0 V is present when pressing the transmitter LOCK/ARM button three times within 5 seconds.
Power supply (Back-up)	14	Battery voltage is constantly present.
Power supply (Back-up)	15	Battery voltage is constantly present.
Keyless buzzer	16 (OUTPUT)	0 V is present when pressing the transmitter UNLOCK/DISARM or LOCK/ARM button.
Security control module	17	—
Turn signal light (Left)	18 (OUTPUT)	Battery voltage is present when pressing the transmitter UNLOCK/DISARM or LOCK/ARM button.

KEYLESS ENTRY SYSTEM

SECURITY AND LOCKS

2. BODY INTEGRATED MODULE

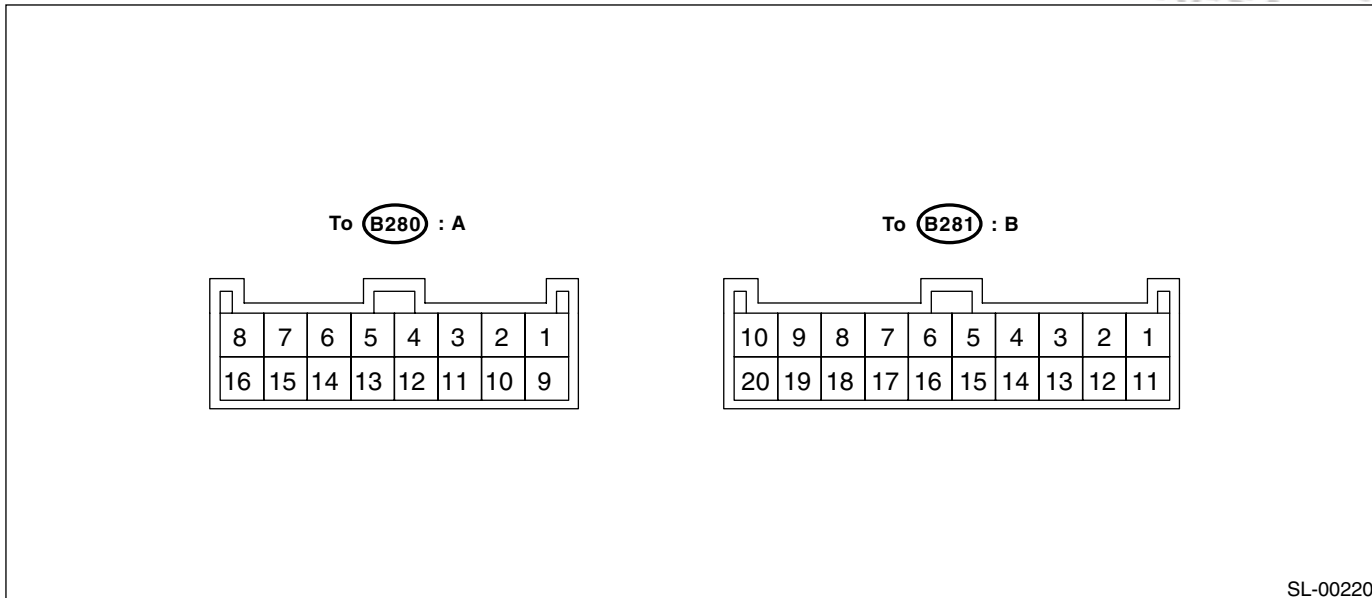

Content	Terminal No.	Measuring condition
Door switch (Except driver's door)	B7 (INPUT)	0 V is present when any door is open (Except driver's door).
Door switch (Driver's door)	B8 (INPUT)	0 V is present when driver's door is open.
Door unlock switch	B11 (INPUT)	0 V is present when operating the door unlock switch.
Door lock switch	B12 (INPUT)	0 V is present when operating the door lock switch.
Keyless entry control module	B13 (INPUT)	Battery voltage is present when pressing the transmitter LOCK/ARM button.
Keyless entry control module	B14 (INPUT)	Battery voltage is present when pressing the transmitter UNLOCK/DISARM button.
Ignition switch (ON)	B19 (INPUT)	Battery voltage is present when ignition switch is turned to ON.
Key warning switch	B20 (INPUT)	Battery voltage is present when inserting the key into ignition switch.
Power supply	A1	Battery voltage is constantly present.
Power supply	A2	Battery voltage is constantly present.
Ground	A4	0 V is constantly present.
Room light	A5 (OUTPUT)	0 V is present when pressing the transmitter UNLOCK/DISARM button.
Door and rear gate lock actuator	A6 (OUTPUT)	Battery voltage is present when pressing the transmitter LOCK/ARM button.
Door and rear gate lock actuator (Except driver side)	A7 (OUTPUT)	Battery voltage is present when pressing the transmitter UNLOCK/DISARM button two times.
Door lock actuator (Driver side)	A8 (OUTPUT)	Battery voltage is present when pressing the transmitter UNLOCK/DISARM button one time.
Ground	A13	0 V is constantly present.

C: INSPECTION

1. SYMPTOM CHART

Symptom	Repair order	Reference
None of the functions of the keyless entry system operate.	1. Check the transmitter battery and function.	<Ref. to SL-14, CHECK TRANSMITTER BATTERY AND FUNCTION, INSPECTION, Keyless Entry System.>
	2. Check the fuse.	<Ref. to SL-15, CHECK FUSE, INSPECTION, Keyless Entry System.>
	3. Check the keyless entry control module power supply and ground circuit.	<Ref. to SL-15, CHECK POWER SUPPLY AND GROUND CIRCUIT, INSPECTION, Keyless Entry System.>
	4. Replace the keyless entry control module.	<Ref. to SL-51, Keyless Entry Control Module.>
The transmitter cannot be programmed.	1. Check the transmitter battery and function.	<Ref. to SL-14, CHECK TRANSMITTER BATTERY AND FUNCTION, INSPECTION, Keyless Entry System.>
	2. Check the ignition switch circuit.	<Ref. to SL-16, CHECK IGNITION SWITCH CIRCUIT, INSPECTION, Keyless Entry System.>
	3. Check the door switch.	<Ref. to SL-16, CHECK DOOR SWITCH, INSPECTION, Keyless Entry System.>
	4. Replace the keyless entry control module.	<Ref. to SL-51, Keyless Entry Control Module.>
The door lock or unlock does not operate. NOTE: If the door lock control system does not operate when using the door lock switch, check the door lock control system. <Ref. to SL-8, INSPECTION, Door Lock Control System.>	1. Check the transmitter battery and function.	<Ref. to SL-14, CHECK TRANSMITTER BATTERY AND FUNCTION, INSPECTION, Keyless Entry System.>
	2. Check the key warning switch.	<Ref. to SL-17, CHECK KEY WARNING SWITCH, INSPECTION, Keyless Entry System.>
	3. Check the door switch.	<Ref. to SL-16, CHECK DOOR SWITCH, INSPECTION, Keyless Entry System.>
	4. Check the output signal to body integrated module.	<Ref. to SL-18, CHECK OUTPUT SIGNAL TO BODY INTEGRATED MODULE, INSPECTION, Keyless Entry System.>
	5. Replace the keyless entry control module.	<Ref. to SL-51, Keyless Entry Control Module.>
The panic alarm does not operate.	1. Check the transmitter battery and function.	<Ref. to SL-14, CHECK TRANSMITTER BATTERY AND FUNCTION, INSPECTION, Keyless Entry System.>
	2. Check the horn operation.	<Ref. to SL-19, CHECK HORN OPERATION, INSPECTION, Keyless Entry System.>
	3. Replace the keyless entry control module.	<Ref. to SL-51, Keyless Entry Control Module.>

KEYLESS ENTRY SYSTEM

SECURITY AND LOCKS

Symptom	Repair order	Reference
The buzzer chirp and hazard light do not operate.	1. Check the buzzer chirp function.	<Ref. to SL-15, CHECK BUZZER CHIRP SETTING, INSPECTION, Keyless Entry System.>
	2. Check the buzzer and hazard light operation.	Buzzer <Ref. to SL-19, CHECK KEYLESS BUZZER, INSPECTION, Keyless Entry System.>
		Hazard light <Ref. to SL-19, CHECK HAZARD LIGHT OPERATION, INSPECTION, Keyless Entry System.>
	3. Replace the keyless entry control module.	<Ref. to SL-51, Keyless Entry Control Module.>
The room light operation do not activate.	1. Check the room light operation.	<Ref. to SL-18, CHECK ROOM LIGHT OPERATION, INSPECTION, Keyless Entry System.>
	2. Replace the keyless entry control module.	<Ref. to SL-51, Keyless Entry Control Module.>
The door warning does not operate.	1. Check the door switch.	<Ref. to SL-16, CHECK DOOR SWITCH, INSPECTION, Keyless Entry System.>
	2. Check the buzzer operation.	<Ref. to SL-19, CHECK KEYLESS BUZZER, INSPECTION, Keyless Entry System.>
	3. Replace the keyless entry control module.	<Ref. to SL-51, Keyless Entry Control Module.>

2. CHECK TRANSMITTER BATTERY AND FUNCTION

Step	Check	Yes	No
1 CHECK TRANSMITTER BATTERY. 1)Remove the battery from the transmitter. <Ref. to SL-53, REMOVAL, Keyless Transmitter.> 2)Check the battery voltage. <Ref. to SL-53, INSPECTION, Keyless Transmitter.>	Is the voltage more than 2 V?	Go to step 2.	Replace the transmitter battery.
2 CHECK LED OF TRANSMITTER. 1)Press the LOCK/ARM or UNLOCK/DISARM button six times to synchronize with the keyless entry control module. 2)Press the LOCK/ARM button.	Does the LED blink one time?	Go to step 3.	Replace the transmitter. <Ref. to SL-53, REPLACEMENT, Keyless Transmitter.>
3 CHECK LED OF TRANSMITTER. Keep the LOCK/ARM button pressed.	Does the LED blink one time, and then turn on?	Go to step 4.	Replace the transmitter. <Ref. to SL-53, REPLACEMENT, Keyless Transmitter.>
4 CHECK LED OF TRANSMITTER. Press the UNLOCK/DISARM button.	Does the LED blink one time?	Go to step 5.	Replace the transmitter. <Ref. to SL-53, REPLACEMENT, Keyless Transmitter.>
5 CHECK LED OF TRANSMITTER. Keep the UNLOCK/DISARM button pressed.	Does the LED blink two times?	Transmitter is OK.	Replace the transmitter. <Ref. to SL-53, REPLACEMENT, Keyless Transmitter.>

3. CHECK BUZZER CHIRP SETTING

Step	Check	Yes	No
1 CHECK BUZZER CHIRP SETTING. 1)Check the current setting of the buzzer chirp. 2)Remove the key from the ignition switch. 3)Close all doors and the rear gate. 4)Press the LOCK/ARM or UNLOCK/DISARM button.	Does the buzzer signal chirp?	Buzzer chirp function is OK.	Go to step 2.
2 CHECK BUZZER CHIRP SETTING. 1)Press the UNLOCK/DISARM button once. 2)Press both the LOCK/ARM and UNLOCK/DISARM buttons for more than 2 seconds. 3)Press the LOCK/ARM or UNLOCK/DISARM button.	Does the buzzer signal chirp?	Buzzer chirp function is OK.	Check the transmitter function. <Ref. to SL-14, CHECK TRANSMITTER BATTERY AND FUNCTION, INSPECTION, Keyless Entry System.>

4. CHECK FUSE

Step	Check	Yes	No
1 CHECK FUSE. Remove and visually check the fuse No. 6 (in the main fuse box) and No. 3 (in the fuse and relay box).	Is the fuse blown out?	Replace the fuse with a new one.	Check the power supply and ground circuit. <Ref. to SL-15, CHECK POWER SUPPLY AND GROUND CIRCUIT, Keyless Entry System.>

5. CHECK POWER SUPPLY AND GROUND CIRCUIT

Step	Check	Yes	No
1 CHECK POWER SUPPLY. 1)Disconnect the keyless entry control module harness connector. 2)Measure the voltage between the harness connector terminal and chassis ground. <i>Connector & terminal</i> <i>(B176) No. 14, No. 15 (+) — Chassis ground (-):</i>	Is the voltage more than 10 V?	Go to step 2.	Check the harness for open circuits and shorts between the keyless entry control module and fuse.
2 CHECK GROUND CIRCUIT. Measure the resistance between the harness connector terminal and chassis ground. <i>Connector & terminal</i> <i>(B176) No. 11 — Chassis ground:</i>	Is the resistance less than 10 Ω ?	The power supply and ground circuit are OK.	Repair the harness.

KEYLESS ENTRY SYSTEM

SECURITY AND LOCKS

6. CHECK IGNITION SWITCH CIRCUIT

Step	Check	Yes	No
1 CHECK IGNITION SWITCH SIGNAL. 1) Disconnect the keyless entry control module harness connector. 2) Turn the ignition switch to ON. 3) Measure the voltage between harness connector terminal and chassis ground. Connector & terminal (B176) No. 6 (+) — Chassis ground (-):	Is the voltage more than 10 V?	Ignition switch circuit is OK.	Check the harness for open circuits and shorts between the keyless entry control module and ignition relay.

7. CHECK DOOR SWITCH

Step	Check	Yes	No
1 CHECK DOOR SWITCH CIRCUIT. Measure the voltage between the keyless entry control module harness connector terminal and chassis ground. Connector & terminal Front and rear side door: (B176) No. 10 (+) — Chassis ground (-): Rear gate: (B176) No. 9 (+) — Chassis ground (-):	Is the voltage 0 V when each door or rear gate is opened?	Go to step 2.	Go to step 3.
2 CHECK DOOR SWITCH CIRCUIT. Measure the voltage between the keyless entry control module harness connector terminal and chassis ground. Connector & terminal Front and rear side door: (B176) No. 10 (+) — Chassis ground (-): Rear gate: (B176) No. 9 (+) — Chassis ground (-):	Is the voltage more than 10 V when each door or rear gate is closed?	The door switch is OK.	Go to step 3.
3 CHECK DOOR SWITCH. 1) Disconnect the door switch harness connector. 2) Measure the resistance between the door switch terminals. Terminals Door switch No. 1 — No. 3: Rear gate latch switch No. 1 — No. 2:	Is the resistance more than 1 M Ω when the door switch is depressed?	Go to step 4.	Replace the door switch.
4 CHECK DOOR SWITCH. Measure the resistance between the door switch terminals. Terminals Door switch No. 1 — No. 3: Rear gate latch switch No. 1 — No. 2:	Is the resistance less than 1 Ω when the door switch is released?	Check the harness for open circuits and shorts between the body integrated module and door switch.	Replace the door switch.

8. CHECK KEY WARNING SWITCH

Step	Check	Yes	No
1 CHECK FUSE. Remove and visually check the fuse No. 6 (in the main fuse box).	Is the fuse blown out?	Replace the fuse with a new one.	Go to step 2.
2 CHECK KEY WARNING SWITCH CIRCUIT. 1) Disconnect the keyless entry control module harness connector. 2) Insert the key into the ignition switch. (LOCK position) 3) Measure the voltage between the harness connector terminal and chassis ground. Connector & terminal (B176) No. 7 (+) — Chassis ground (-):	Is the voltage more than 10 V?	Go to step 3.	Go to step 4.
3 CHECK KEY WARNING SWITCH CIRCUIT. 1) Remove the key from the ignition switch. 2) Measure the voltage between the harness connector terminal and chassis ground. Connector & terminal (B176) No. 7 (+) — Chassis ground (-):	Is the voltage 0 V?	Key warning switch is OK.	Go to step 4.
4 CHECK KEY WARNING SWITCH. 1) Disconnect the key warning switch harness connector. 2) Insert the key into the ignition switch. (LOCK position) 3) Measure the resistance between the key warning switch terminals. Terminals No. 1 — No. 2:	Is the resistance less than 1 Ω ?	Go to step 5.	Replace the key warning switch.
5 CHECK KEY WARNING SWITCH. 1) Remove the key from the ignition switch. 2) Measure the resistance between the key warning switch terminals. Terminals No. 1 — No. 2:	Is the resistance more than 1 M Ω ?	Check the following: • Harness for open circuits and shorts between the key warning switch and fuse • Harness for open circuits and shorts between the keyless entry control module and key warning switch	Replace the key warning switch.

KEYLESS ENTRY SYSTEM

SECURITY AND LOCKS

9. CHECK ROOM LIGHT OPERATION

Step	Check	Yes	No
1 CHECK ROOM LIGHT OPERATION. Make sure the room light illuminates when the room light switch is turned ON.	Does the room light illuminate?	Go to step 2.	Check the room light circuit.
2 CHECK HARNESS BETWEEN ROOM LIGHT AND BODY INTEGRATED MODULE. 1) Disconnect the body integrated module harness connector and room light harness connector. 2) Measure the resistance between the body integrated module harness connector terminal and the room light harness connector terminal. <i>Connector & terminal</i> <i>(B280) No. 5 — (R52) No. 2:</i>	Is the resistance less than 10 Ω ?	The room light operation circuit is OK.	Check the harness for open circuits and/or shorts between the body integrated module and room light.

10. CHECK OUTPUT SIGNAL TO BODY INTEGRATED MODULE

Step	Check	Yes	No
1 CHECK OUTPUT SIGNAL. Measure the voltage between the keyless entry control module harness connector terminal and chassis ground when UNLOCK/DISARM button of transmitter is pressed. <i>Connector & terminal</i> <i>(B176) No. 2 (+) — Chassis ground (-):</i>	Is the voltage more than 10 V?	Go to step 2.	Replace the keyless entry control module.
2 CHECK OUTPUT SIGNAL. Measure the voltage between the keyless entry control module harness connector terminal and chassis ground when LOCK/ARM button of transmitter is pressed. <i>Connector & terminal</i> <i>(B176) No. 1 (+) — Chassis ground (-):</i>	Is the voltage more than 10 V?	Go to step 3.	Replace the keyless entry control module.
3 CHECK HARNESS BETWEEN KEYLESS ENTRY CONTROL MODULE AND BODY INTEGRATED MODULE. 1) Disconnect the keyless entry control module harness connector and body integrated module harness connector. 2) Measure the resistance between the keyless entry control module harness connector terminal and body integrated module harness connector terminal. <i>Connector & terminal</i> <i>(B176) No. 2 — (B281) No. 14:</i> <i>(B176) No. 1 — (B281) No. 13:</i>	Is the resistance less than 10 Ω ?	Replace the body integrated module.	Check the harness for open circuit or shorts between the keyless entry control module and body integrated module.

KEYLESS ENTRY SYSTEM

SECURITY AND LOCKS

11. CHECK HORN OPERATION

Step	Check	Yes	No
1 CHECK HORN OPERATION. Make sure the horn sounds when the horn switch is pushed.	Does the horn sound?	Go to step 2.	Check the horn circuit.
2 CHECK HORN OPERATION. 1) Disconnect the keyless entry control module harness connector. 2) Ground the harness connector terminal with a suitable wire. Connector & terminal (B176) No. 13 — Chassis ground:	Does the horn sound?	Replace the keyless entry control module.	Check the harness for open circuits and/or shorts between the keyless entry control module and horn relay.

12. CHECK HAZARD LIGHT OPERATION

Step	Check	Yes	No
1 CHECK HAZARD LIGHT OPERATION. Make sure the hazard light blinks when hazard switch is turned ON.	Does the hazard light blink?	Go to step 2.	Check the hazard light circuit.
2 CHECK OUTPUT SIGNAL. 1) Remove the key from ignition switch. 2) Close all doors and rear gate. 3) Measure the voltage between keyless entry control module harness connector terminal and chassis ground when LOCK/ARM button of transmitter is pressed. Connector & terminal (B176) No. 12, 18 (+) — Chassis ground (-):	Is the voltage more than 10 V?	Check the harness for open or short between keyless entry control module and turn signal lights.	Replace the keyless entry control module.

13. CHECK KEYLESS BUZZER

Step	Check	Yes	No
1 CHECK FUSE. Remove and check the fuse No. 2 (located in main fuse box).	Is the fuse blown out?	Replace the fuse with a new one.	Go to step 2.
2 CHECK KEYLESS POWER SUPPLY. 1) Disconnect the connector from keyless buzzer. 2) Measure the voltage between keyless buzzer harness connector and chassis ground. Connector & terminal (F102) No. 2 (+) — Chassis ground (-):	Is the voltage more than 10 V?	Go to step 3.	Check the harness for open or short between fuse and keyless buzzer.
3 CHECK HARNESS BETWEEN KEYLESS BUZZER AND KEYLESS ENTRY CONTROL MODULE. 1) Disconnect the connector from keyless entry control module. 2) Measure the resistance between keyless buzzer and keyless entry control module. Connector & terminal (F102) No. 1 — (B176) No. 16:	Is the resistance more than 10 Ω ?	Go to step 4.	Repair the harness between keyless buzzer and keyless entry control module.
4 CHECK KEYLESS BUZZER. Make sure that the buzzer sounds when connecting battery positive terminal to No. 2 terminal of keyless buzzer connector and battery ground terminal to No. 1 terminal of keyless buzzer connector.	Does the buzzer sound?	Replace the keyless entry control module.	Replace the keyless buzzer.

SECURITY SYSTEM

SECURITY AND LOCKS

4. Security System

A: SCHEMATIC

<Ref. to WI-159, SCHEMATIC, Security System.>

B: ELECTRICAL SPECIFICATION

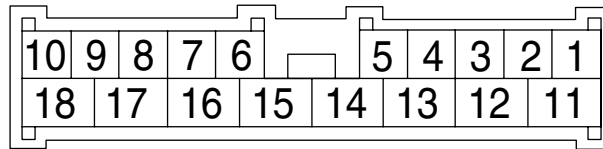

SL-00037

Content	Terminal No.	Measuring condition
Empty	1	—
Ignition switch (ON)	2 (INPUT)	Battery voltage is present when ignition switch is turned to ON.
Passive arm	3	—
Trunk room light switch (Sedan model)	4 (INPUT)	0 V is present when trunk lid or rear gate is open.
Rear gate latch switch (Wagon model)		
Door switch	5 (INPUT)	0 V is present when any door is open.
Empty	6	—
Keyless entry control module	7	—
Keyless entry control module	8	—
Security indicator light	9 (OUTPUT)	0 V is present when activating the alarm operation.
Keyless entry control module	10	—
Power supply (Back-up)	13	Battery voltage is constantly present.
Ground	14	0 V is constantly present.
Interrupt relay	15 (OUTPUT)	Battery voltage is present when activating the alarm operation.
Security horn relay	16 (INPUT)	Battery voltage is present when activating the alarm operation.
Security horn	17 (OUTPUT)	Battery voltage is present when activating the alarm operation.
Security horn relay	18 (INPUT)	Battery voltage is present when activating the alarm operation.

C: INSPECTION

1. BASIC DIAGNOSTIC PROCEDURE

Step	Check	Yes	No	
1	CHECK VALET MODE SETTING. Check the valet mode is set. (Security indicator light blinks two times per a second when the valet mode is set.)	Does the security indicator light blink two times per a second?	Go to step 2.	Go to step 3.
2	RELEASE VALET MODE SETTING. Release the valet mode setting. 1)Open the driver's door. 2)Push the UNLOCK/DISARM button on transmitter for two seconds or more.	Does the security indicator light blink one time per two seconds?	Go to step 3.	Go to symptom 1. <Ref. to SL-22, SYMPTOM CHART, INSPECTION, Security System.>
3	CHECK SECURITY SYSTEM SET OPERATION. 1)Before starting this diagnosis, open all windows. 2)Remove the key from ignition key cylinder, and then close all doors and rear gate. 3)Press the LOCK/ARM button of transmitter.	Can the security system be set?	Go to step 4.	Go to symptom 1. <Ref. to SL-22, SYMPTOM CHART, INSPECTION, Security System.>
4	CHECK SECURITY INDICATOR LIGHT AND HAZARD LIGHT BLINKING. Check the security indicator light and hazard light blinking.	Do the security indicator light and hazard light blink?	Go to step 5.	Go to symptom 2. <Ref. to SL-22, SYMPTOM CHART, INSPECTION, Security System.>
5	CHECK SECURITY ALARM OPERATION. 1)Unlock all doors using the door lock switch on front door. 2)Open any door, trunk lid or rear gate.	Does the security alarm operate when any door, trunk lid or rear gate is opened?	Go to step 6.	Go to symptom 3. <Ref. to SL-22, SYMPTOM CHART, INSPECTION, Security System.>
6	CHECK SECURITY ALARM OPERATION. Check the security alarm operation.	Does all security alarm (horn, hazard light and security indicator light) operate? And is the starter motor deactivated?	Go to step 7.	Go to symptom 4. <Ref. to SL-22, SYMPTOM CHART, INSPECTION, Security System.>
7	CHECK SECURITY ALARM CANCEL OPERATION. Press the UNLOCK/DISARM button of transmitter.	Do all security alarm (horn and hazard light) stop? And is the starter motor activated?	Go to step 8.	Go to symptom 5. <Ref. to SL-22, SYMPTOM CHART, INSPECTION, Security System.>
8	CHECK BATTERY DISCONNECT PROTECTION. Check the battery disconnect protection. <Ref. to SL-22, CHECK BATTERY DISCONNECT PROTECTION, INSPECTION, Security System.>	Is the battery disconnect protection OK?	Go to step 9.	Replace the security control module.
9	PERFORM IMPACT SENSITIVITY TEST. Perform the impact sensitivity test. <Ref. to SL-46, IMPACT SENSITIVITY TEST, INSPECTION, Security Control Module.>	Is the impact sensitivity properly set?	Press the UNLOCK/DISARM button of transmitter, and finish the diagnosis.	Adjust the impact sensitivity.<Ref. to SL-47, IMPACT SENSITIVITY, ADJUSTMENT, Security Control Module.>

SECURITY SYSTEM

SECURITY AND LOCKS

2. CHECK BATTERY DISCONNECT PROTECTION

- 1) Remove the key from the ignition switch.
 - 2) Close all the doors, trunk lid and rear gate.
 - 3) Open the front hood.
 - 4) Press the LOCK/ARM button of the transmitter.
 - 5) Disconnect the ground cable from the battery.
 - 6) Reconnect the cable to the battery.
 - 7) Check that the security indicator light blinks after reconnecting the battery cable.
- If NG, replace the security control module.

3. SYMPTOM CHART

Symptom		Repair order	Reference
1	Security system cannot be set.	1. Check the transmitter function.	<Ref. to SL-14, CHECK TRANSMITTER BATTERY AND FUNCTION, INSPECTION, Keyless Entry System.>
		2. Check the fuse.	<Ref. to SL-23, CHECK FUSE, INSPECTION, Security System.>
		3. Check the security control module power supply and ground circuit.	<Ref. to SL-23, CHECK POWER SUPPLY AND GROUND CIRCUIT, INSPECTION, Security System.>
		4. Check the door switch.	<Ref. to SL-23, CHECK DOOR SWITCH, INSPECTION, Security System.>
		5. Replace the security control module.	<Ref. to SL-46, Security Control Module.>
2	Security indicator light or hazard light does not blink.	Security indicator light	<Ref. to SL-24, CHECK SECURITY INDICATOR LIGHT CIRCUIT, INSPECTION, Security System.>
		Hazard light	<Ref. to SL-26, CHECK HAZARD LIGHT OPERATION, INSPECTION, Security System.>
3	Security system does not alarm when one of the door, trunk lid or rear gate is opened.	Check the door switch.	<Ref. to SL-23, CHECK DOOR SWITCH, INSPECTION, Security System.>
4	Security alarm does not activate.	All functions	Check the door switch. <Ref. to SL-23, CHECK DOOR SWITCH, INSPECTION, Security System.>
		Security indicator light	Check the security indicator light circuit. <Ref. to SL-24, CHECK SECURITY INDICATOR LIGHT CIRCUIT, INSPECTION, Security System.>
		Security horn	Check the security horn. <Ref. to SL-25, CHECK SECURITY HORN, INSPECTION, Security System.>
		Hazard light	Check the hazard light operation. <Ref. to SL-26, CHECK HAZARD LIGHT OPERATION, INSPECTION, Security System.>
		Starter motor deactivation	Check the interrupt relay circuit. <Ref. to SL-27, CHECK INTERRUPT RELAY CIRCUIT, INSPECTION, Security System.>
5	Security system cannot be canceled.	Transmitter	Check the transmitter function. <Ref. to SL-14, CHECK TRANSMITTER BATTERY AND FUNCTION, INSPECTION, Keyless Entry System.>
		Ignition switch	Check the ignition switch circuit. <Ref. to SL-27, CHECK IGNITION SWITCH CIRCUIT, INSPECTION, Security System.>

4. CHECK FUSE

Step	Check	Yes	No	
1	CHECK FUSE. Remove and visually check the fuse No. 2 (in main fuse box).	Is the fuse blown out?	Check the power supply and ground circuit. <Ref. to SL-23, CHECK POWER SUPPLY AND GROUND CIRCUIT, INSPECTION, Security System.>	Replace the fuse with a new one.

5. CHECK POWER SUPPLY AND GROUND CIRCUIT

Step	Check	Yes	No	
1	CHECK POWER SUPPLY. 1)Disconnect the security control module harness connector. 2)Measure the voltage between the harness connector terminal and chassis ground. <i>Connector & terminal</i> <i>(B93) No. 13 (+) — Chassis ground (-):</i>	Is the voltage more than 10 V?	Go to step 2.	Check the harness for open circuits and shorts between the security control module and fuse.
2	CHECK GROUND CIRCUIT. Measure the resistance between the harness connector terminal and chassis ground. <i>Connector & terminal</i> <i>(B93) No. 14 — Chassis ground:</i>	Is the resistance less than 10 Ω?	The power supply and ground circuit are OK.	Repair the harness.

6. CHECK DOOR SWITCH

Step	Check	Yes	No	
1	CHECK DOOR SWITCH CIRCUIT. Measure the voltage between the security control module harness connector terminal and chassis ground when any door or rear gate is opened. <i>Connector & terminal</i> <i>Front and rear door:</i> <i>(B93) No. 5 (+) — Chassis ground (-):</i> <i>Trunk lid or rear gate:</i> <i>(B93) No. 4 (+) — Chassis ground (-):</i>	Is the voltage 0 V?	Go to step 2.	Go to step 3.
2	CHECK DOOR SWITCH CIRCUIT. Measure the voltage between the security control module harness connector terminal and chassis ground when all doors and rear gate are closed. <i>Connector & terminal</i> <i>Front and rear door:</i> <i>(B93) No. 5 (+) — Chassis ground (-):</i> <i>Trunk lid or rear gate:</i> <i>(B93) No. 4 (+) — Chassis ground (-):</i>	Is the voltage more than 10 V?	The door switch is OK.	Go to step 3.

SECURITY SYSTEM

SECURITY AND LOCKS

Step	Check	Yes	No
3 CHECK DOOR SWITCH. 1) Disconnect the door switch harness connector. 2) Measure the resistance between the door switch terminals. Terminals Door switch No. 1 — No. 3: Rear gate latch switch (Wagon model) No. 1 — No. 2: Trunk room light switch (Sedan model) No. 1 — No. 2:	Is the resistance more than 1 M Ω when door switch is pushed?	Go to step 4.	Replace the door switch.
4 CHECK DOOR SWITCH. Measure the resistance between the door switch terminals. Terminals Door switch No. 1 — No. 3: Rear gate latch switch (Wagon model) No. 1 — No. 2: Trunk room light switch (Sedan model) No. 1 — No. 2:	Is the resistance less than 1 Ω when door switch is released?	Check the harness for open circuits and shorts between the security control module and door switch.	Replace the door switch.

7. CHECK SECURITY INDICATOR LIGHT CIRCUIT

Step	Check	Yes	No
1 CHECK SECURITY INDICATOR LIGHT. 1) Disconnect the security control module harness connector. 2) Ground the harness connector terminal with a suitable wire. Connector & terminal (B93) No. 9 — Chassis ground:	Does the security indicator light illuminate?	Replace the security control module.	Go to step 2.
2 CHECK POWER SUPPLY FOR SECURITY INDICATOR LIGHT. 1) Disconnect the connector from the combination meter. 2) Measure the voltage between the combination meter harness connector terminal and chassis ground. Connector & terminal (i11) No. 3 (+) — Chassis ground (-):	Is the voltage more than 10 V?	Go to step 3.	Check the harness for open circuits and shorts between the combination meter and the fuse.
3 CHECK SECURITY INDICATOR LIGHT CIRCUIT. Measure the resistance between the combination meter harness connector terminal and security control module harness connector terminal. Connector & terminal (i10) No. 6 — (B93) No. 9:	Is the resistance less than 10 Ω ?	Replace the combination meter printed circuit.	Check the harness for open circuits and shorts between the combination meter and security control module.

8. CHECK SECURITY HORN

Step	Check	Yes	No
1 CHECK SECURITY HORN RELAY. Remove and check the security horn relay. <Ref. to SL-49, Security Horn Relay.>	Is the security horn relay OK?	Go to step 2 .	Replace the security horn relay.
2 CHECK POWER SUPPLY FOR SECURITY HORN RELAY. Measure the voltage between the security horn relay harness connector terminal and chassis ground. <i>Connector & terminal</i> <i>(B243) No. 1 (+) — Chassis ground (-):</i>	Is the voltage more than 10 V?	Go to step 3 .	Check the harness for open circuits and shorts between the security horn relay and horn relay.
3 CHECK POWER SUPPLY FOR SECURITY HORN RELAY. Measure the voltage between the security horn relay harness connector terminal and chassis ground. <i>Connector & terminal</i> <i>(B243) No. 2 (+) — Chassis ground (-):</i>	Is the voltage more than 10 V?	Go to step 4 .	Check the harness for open circuits and shorts between the security horn relay and the fuse.
4 CHECK HARNESS BETWEEN SECURITY HORN RELAY AND SECURITY CONTROL MODULE. 1)Disconnect the security control module harness connector. 2)Measure the resistance between the security horn relay harness connector terminal and security control module harness connector terminal. <i>Connector & terminal</i> <i>(B243) No. 3 — (B93) No. 18:</i>	Is the resistance less than 10 Ω ?	Go to step 5 .	Check the harness for open circuits and shorts between the security horn relay and security control module.
5 CHECK HARNESS BETWEEN SECURITY HORN RELAY AND SECURITY CONTROL MODULE. Measure the resistance between the security horn relay harness connector terminal and security control module harness connector terminal. <i>Connector & terminal</i> <i>(B243) No. 4 — (B93) No. 16:</i>	Is the resistance less than 10 Ω ?	Go to step 6 .	Check the harness for open circuits and shorts between the security horn relay and security control module.
6 CHECK HARNESS BETWEEN SECURITY CONTROL MODULE AND SECURITY HORN. 1)Disconnect the security horn harness connector. 2)Measure the resistance between the security control module harness connector terminal and security horn harness connector terminal. <i>Connector & terminal</i> <i>(B93) No. 17 — (B204) No. 1:</i>	Is the resistance less than 10 Ω ?	Go to step 7 .	Check the harness for open circuits and shorts between the security control module and security horn.
7 CHECK SECURITY HORN. Remove and check the security horn. <Ref. to SL-48, Security Horn.>	Is the security horn OK?	Replace the security control module.	Replace the security horn.

SECURITY SYSTEM

SECURITY AND LOCKS

9. CHECK HAZARD LIGHT OPERATION

Step	Check	Yes	No
1 CHECK SECURITY CONTROL MODULE OUTPUT SIGNAL. 1) Remove the key from the ignition switch. 2) Open the driver's window, and then close all doors and rear gate. 3) Lock all doors with the transmitter or door lock switch to arm the security system. 4) Unlock all doors with the door lock switch. 5) Measure the voltage between the security control module harness connector terminal and chassis ground when any door is open. <i>Connector & terminal</i> <i>(B93) No. 10 — Chassis ground:</i>	Is the voltage 1 — 4 V?	Go to step 2.	Replace the security control module.
2 CHECK HARNESS BETWEEN SECURITY CONTROL MODULE AND KEYLESS ENTRY CONTROL MODULE. 1) Disconnect the security control module harness connector and keyless entry control module harness connector. 2) Measure the resistance between the security control module harness connector terminal and keyless entry control module harness connector terminal. <i>Connector & terminal</i> <i>(B93) No. 10 — (B176) No. 3:</i>	Is the resistance less than 10 Ω ?	Check the hazard light output of keyless entry control module.<Ref. to SL-19, CHECK HAZARD LIGHT OPERATION, INSPECTION, Keyless Entry System.>	Check the harness for open circuit and shorts between the security control module and keyless entry control module.

10.CHECK INTERRUPT RELAY CIRCUIT

Step	Check	Yes	No
1 CHECK INTERRUPT RELAY. Remove and check the interrupt relay. <Ref. to SL-50, Interrupt Relay.>	Is the interrupt relay OK?	Go to step 2.	Replace the interrupt relay.
2 CHECK POWER SUPPLY FOR INTERRUPT RELAY. Measure the voltage between the interrupt relay harness connector terminal and chassis ground. <i>Connector & terminal</i> <i>(B59) No. 1 (+) — Chassis ground (-):</i>	Is the voltage more than 10 V when ignition switch is turned to START?	Go to step 3.	Check the harness for open circuits and shorts between the interrupt relay and ignition switch.
3 CHECK HARNESS BETWEEN INTERRUPT RELAY AND SECURITY CONTROL MODULE. 1)Turn the ignition switch to OFF. 2)Disconnect the security control module harness connector. 3)Measure the resistance between the interrupt relay harness connector terminal and security control module harness connector terminal. <i>Connector & terminal</i> <i>(B59) No. 4 — (B93) No. 15:</i>	Is the resistance less than 10 Ω?	Replace the security control module.	Check the harness for open circuits and shorts between the interrupt relay and security control module.

11.CHECK IGNITION SWITCH CIRCUIT

Step	Check	Yes	No
1 CHECK IGNITION SWITCH SIGNAL. 1)Disconnect the security control module harness connector. 2)Turn the ignition switch to ON. 3)Measure the voltage between the harness connector terminal and chassis ground. <i>Connector & terminal</i> <i>(B93) No. 2 (+) — Chassis ground (-):</i>	Is the voltage more than 10 V?	Ignition switch circuit is OK.	Check the harness for open circuits and shorts between the security control module and ignition switch.

Brought to you by Eris Studios
NOT FOR RESALE

9. Rear Inner Remote

A: REMOVAL

- 1) Remove the rear door trim. <Ref. to EI-39, REMOVAL, Rear Door Trim.>
- 2) Remove the sealing cover. <Ref. to EB-20, REMOVAL, Rear Sealing Cover.>
- 3) Remove a screw and two rod joints.
- 4) Remove the inner remote.

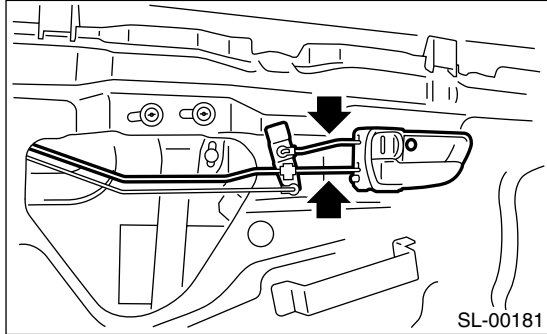

B: INSTALLATION

Install in the reverse order of removal.

NOTE:

Make sure the inner remote works properly after installation.

C: INSPECTION

- 1) Make sure the rod is not deformed.
- 2) Make sure the lever and rod work smoothly.
- 3) Make sure the child safety lock work properly.

6. Front Outer Handle

A: REMOVAL

- 1) Remove the door trim. <Ref. to EI-38, REMOVAL, Front Door Trim.>
- 2) Remove the sealing cover. <Ref. to EB-17, REMOVAL, Front Sealing Cover.>
- 3) Remove the bolt (A).
- 4) Move the front door glass downward. Remove the bolt and rod clamp.
- 5) Remove the front outer handle.

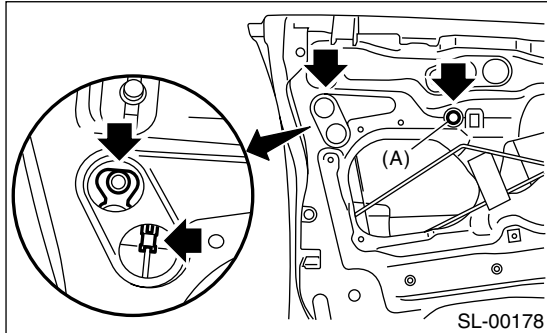

CAUTION:

Do not use excessive force to remove the handle from door panel. This will deform it.

B: INSTALLATION

Install in the reverse order of removal.

NOTE:

Make sure the outer handle works properly after installation.

C: INSPECTION

- 1) Make sure the rod is not deformed.
- 2) Make sure the lever and rod work smoothly.

FRONT DOOR LATCH ASSEMBLY

SECURITY AND LOCKS

7. Front Door Latch Assembly

A: REMOVAL

- 1) Disconnect the ground cable from battery.
- 2) Remove the front door trim. <Ref. to EI-38, REMOVAL, Front Door Trim.>
- 3) Remove the sealing cover. <Ref. to EB-17, REMOVAL, Front Sealing Cover.>
- 4) Remove the front inner remote. <Ref. to SL-28, REMOVAL, Front Inner Remote.>
- 5) Remove three screws and a bolt.

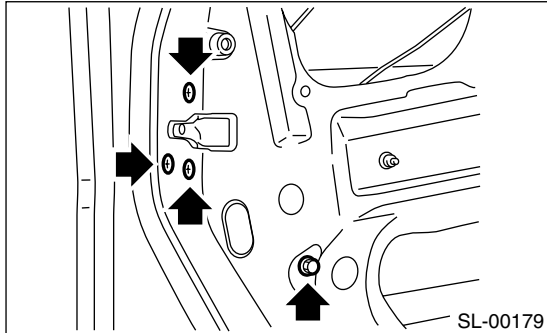

- 6) Remove the front door latch assembly, and then disconnect the connector.

B: INSTALLATION

Install in the reverse order of removal.

NOTE:

Make sure the lock works properly after installation.

C: INSPECTION

- 1) Make sure the rod is not deformed.
- 2) Make sure the lever and rod work smoothly.

8. Front Door Lock Actuator

A: REMOVAL

- 1) Remove the front door latch assembly. <Ref. to SL-30, REMOVAL, Front Door Latch Assembly.>
- 2) Loosen two screws to remove the front door lock actuator.

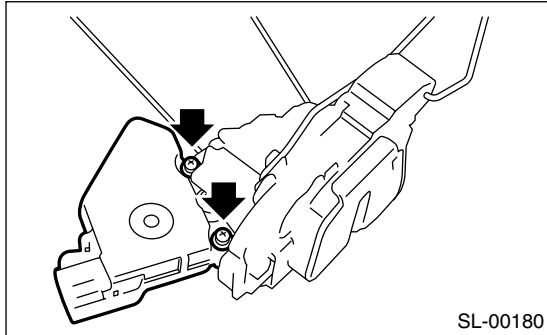

B: INSTALLATION

Install in the reverse order of removal.

NOTE:

Make sure the lock works properly after installation.

C: INSPECTION

- 1) Disconnect the door lock actuator harness connector.
- 2) Connect the battery to door lock actuator terminals.

If NG, replace the door lock actuator.

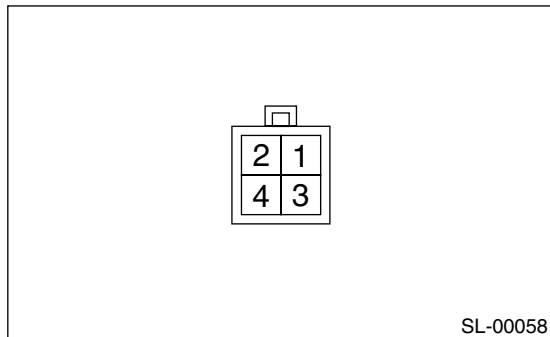

Terminal No.	Actuator operation
No. 3 (+) and No. 1 (-)	Unlocked → Locked
No. 1 (+) and No. 3 (-)	Locked → Unlocked

Brought to you by Eris Studios
NOT FOR RESALE

9. Rear Inner Remote

A: REMOVAL

- 1) Remove the rear door trim. <Ref. to EI-39, REMOVAL, Rear Door Trim.>
- 2) Remove the sealing cover. <Ref. to EB-20, REMOVAL, Rear Sealing Cover.>
- 3) Remove a screw and two rod joints.
- 4) Remove the inner remote.

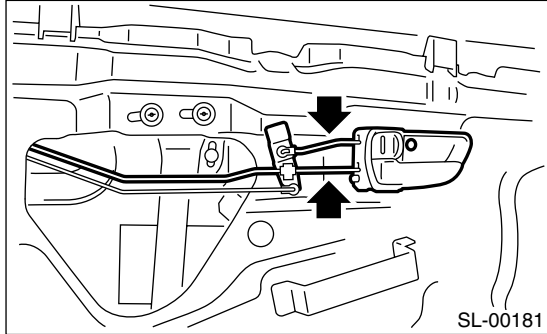

B: INSTALLATION

Install in the reverse order of removal.

NOTE:

Make sure the inner remote works properly after installation.

C: INSPECTION

- 1) Make sure the rod is not deformed.
- 2) Make sure the lever and rod work smoothly.
- 3) Make sure the child safety lock work properly.

10.Rear Outer Handle

A: REMOVAL

- 1) Remove the rear door trim. <Ref. to EI-39, REMOVAL, Rear Door Trim.>
- 2) Remove the sealing cover. <Ref. to EB-20, REMOVAL, Rear Sealing Cover.>
- 3) Remove the rear inner remote. <Ref. to SL-32, REMOVAL, Rear Inner Remote.>
- 4) Remove the rear door latch assembly. <Ref. to SL-34, REMOVAL, Rear Door Latch Assembly.>
- 5) Loosen two bolts and a nut to remove the rear outer handle.

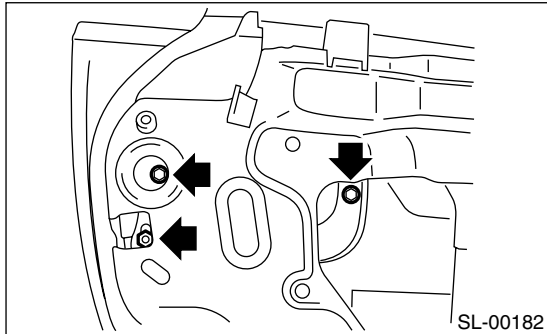

CAUTION:

Do not use excessive force to remove the handle from door panel. This will deform it.

B: INSTALLATION

Install in the reverse order of removal.

NOTE:

Make sure the outer handle works properly after installation.

C: INSPECTION

- 1) Make sure the rod is not deformed.
- 2) Make sure the lever and rod work smoothly.

11. Rear Door Latch Assembly

A: REMOVAL

- 1) Disconnect the ground cable from battery.
- 2) Remove the rear door trim. <Ref. to EI-39, REMOVAL, Rear Door Trim.>
- 3) Remove the sealing cover. <Ref. to EB-20, REMOVAL, Rear Sealing Cover.>
- 4) Remove the rear inner remote. <Ref. to SL-32, REMOVAL, Rear Inner Remote.>
- 5) Remove three screws and a bolt.

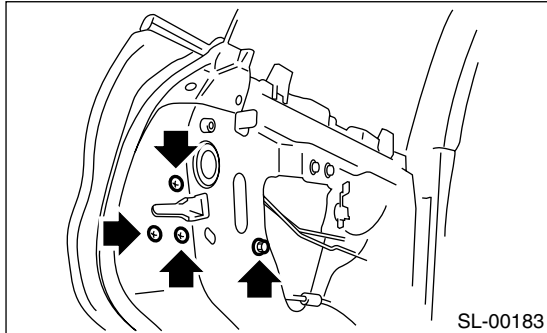

- 6) Disconnect the connector, and then remove the rear door latch assembly.

B: INSTALLATION

Install in the reverse order of removal.

NOTE:

Make sure the lock works properly after installation.

C: INSPECTION

- 1) Make sure the rod is not deformed.
- 2) Make sure the lever and rod work smoothly.

12.Rear Door Lock Actuator

A: REMOVAL

- 1) Remove the rear door latch assembly. <Ref. to SL-34, REMOVAL, Rear Door Latch Assembly.>
- 2) Loosen two screws to remove rear door lock actuator.

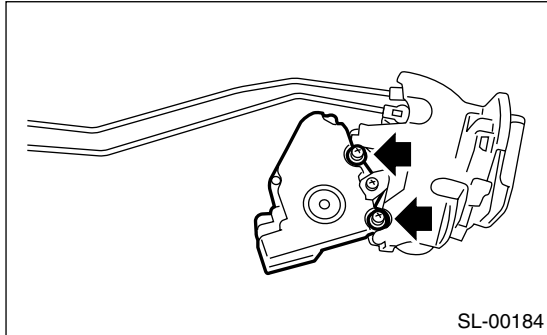

B: INSTALLATION

Install in the reverse order of removal.

NOTE:

Make sure the lock works properly after installation.

C: INSPECTION

- 1) Disconnect the door lock actuator harness connector.
- 2) Connect the battery to door lock actuator terminals.

If NG, replace the door lock actuator.

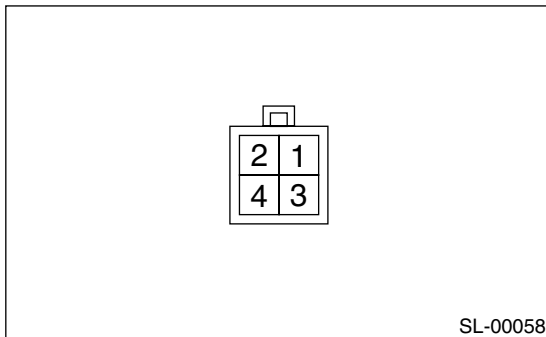

Terminal No.	Actuator operation
No. 3 (+) and No. 1 (-)	Unlocked → Locked
No. 1 (+) and No. 3 (-)	Locked → Unlocked

13.Rear Gate Outer Handle

A: REMOVAL

- 1) Remove the rear gate trim. <Ref. to EI-53, REMOVAL, Rear Gate Trim.>
- 2) Remove the rear gate latch assembly. <Ref. to SL-37, REMOVAL, Rear Gate Latch Assembly.>
- 3) Loosen two nuts to remove the rear gate outer handle.

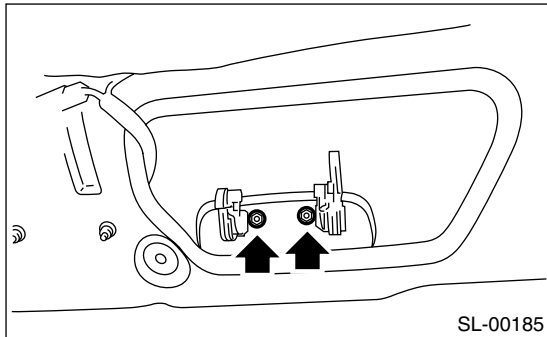

B: INSTALLATION

Install in the reverse order of removal.

NOTE:

Make sure the outer handle works properly after installation.

C: INSPECTION

- 1) Inspect the rod for deformation.
- 2) Make sure the lever and rod move smoothly.

14. Rear Gate Latch Assembly

A: REMOVAL

- 1) Disconnect the ground cable from battery.
- 2) Remove the rear gate trim. <Ref. to EI-53, REMOVAL, Rear Gate Trim.>
- 3) Remove three bolts.

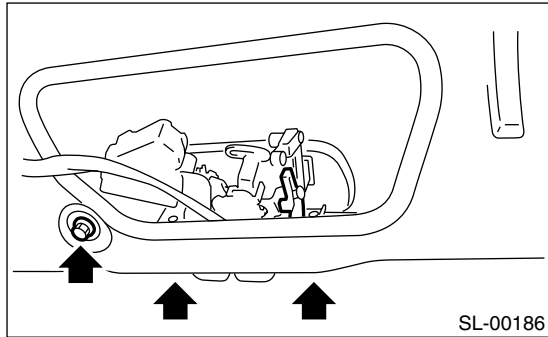

- 4) Disconnect the connectors, and then remove the rear gate latch assembly.

B: INSTALLATION

Install in the reverse order of removal.

NOTE:

Make sure the lock works properly after installation.

C: INSPECTION

- 1) Make sure the rod is not deformed.
- 2) Make sure the lever and rod work smoothly.

REAR GATE LATCH LOCK ACTUATOR

SECURITY AND LOCKS

15. Rear Gate Latch Lock Actuator

A: REMOVAL

- 1) Remove the rear gate latch assembly. <Ref. to SL-37, REMOVAL, Rear Gate Latch Assembly.>
- 2) Loosen two screws to remove the rear gate lock actuator.

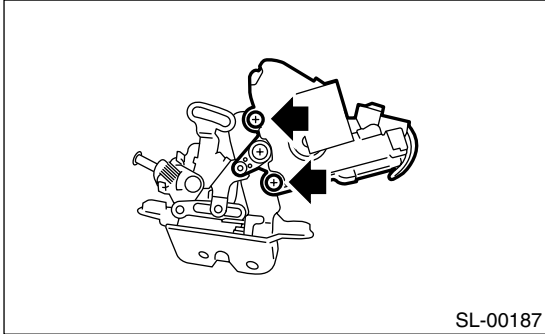

B: INSTALLATION

Install in the reverse order of removal.

NOTE:

Make sure the lock works properly after installation.

C: INSPECTION

- 1) Disconnect the door lock actuator harness connector.
- 2) Connect the battery to door lock actuator terminals.

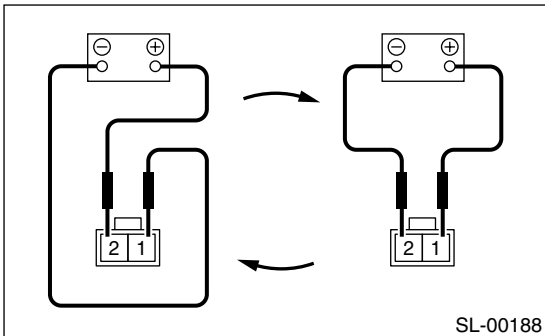

Terminal No.	Actuator operation
No. 1 (+) and No. 2 (-)	Unlocked → Locked
No. 2 (+) and No. 1 (-)	Locked → Unlocked

If NG, replace the rear gate latch lock actuator.

16. Trunk Lid Lock Assembly

A: REMOVAL

- 1) Remove the trunk lid key cylinder rod clamp.
- 2) Loosen two bolts to remove the trunk lid lock assembly.

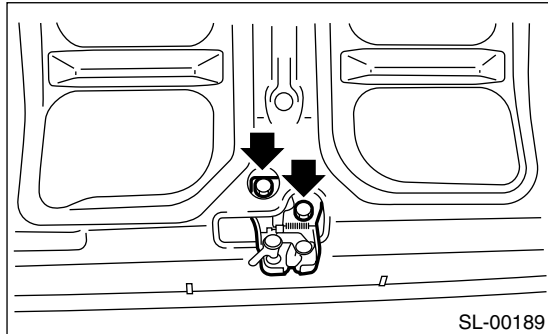

B: INSTALLATION

Install in the reverse order of removal.

NOTE:

- Apply grease to parts that rub.
- Make sure the lock works properly after installation.

C: INSPECTION

- 1) Check the striker for bending or abnormal wear.
- 2) Check the safety lever for improper movement.
- 3) Check other levers and the spring for rust formation and unsmooth movement.

17. Trunk Lid Release Handle

A: REMOVAL

1) Remove the five clips.

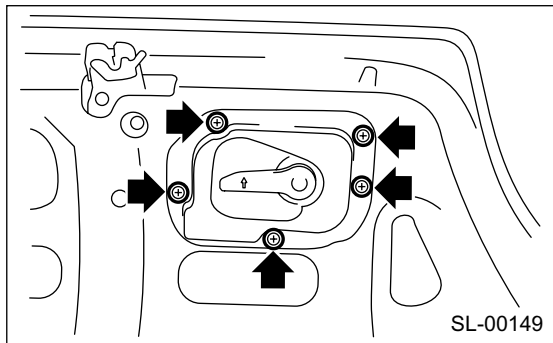

2) Remove the cable from trunk lid release handle.

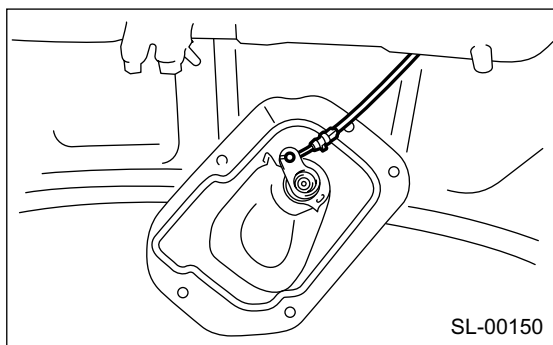

B: INSTALLATION

Install in the reverse order of removal.

C: INSPECTION

- 1) Make sure the cable is not deformed.
- 2) Make sure the lever works smoothly.

18. Front Hood Lock Assembly

A: REMOVAL

- 1) Open the hood.
- 2) Remove the bolts. Remove the hood lock assembly.
- 3) Remove the release cable from lock assembly.

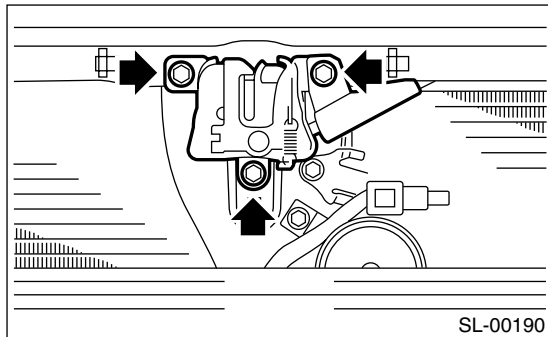

B: INSTALLATION

Install in the reverse order of removal.

NOTE:

- Apply grease to parts that rub.
- Make sure the release cable works properly after installation.

C: ADJUSTMENT

Loosen the bolt. Adjust the lock assembly while moving it up and down.

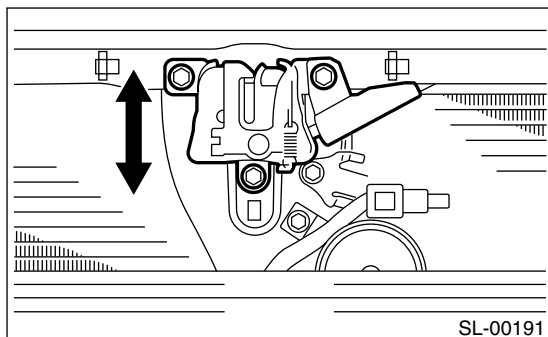

D: INSPECTION

- 1) Check the striker for bending or abnormal wear.
- 2) Check the safety lever for improper movement.
- 3) Check other levers and the spring for rust formation and unsmooth movement.

19. Remote Openers

A: REMOVAL

1. HOOD OPENER

- 1) Remove the release cable from hood lock.
- 2) Remove the bolt. Remove the opener lever.

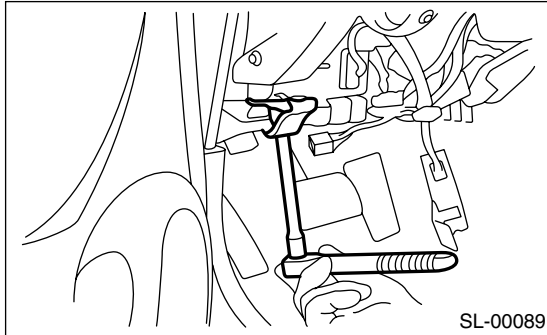

2. TRUNK LID OPENER

- 1) Remove the rear seat. <Ref. to SE-16, REMOVAL, Rear Seat.>
- 2) Remove the center pillar lower trim, and remove the side sill cover on passenger side. Remove the rear pillar lower trim. Pull back the floor mat. Remove the clip holding the cable.
- 3) Remove the bolt. Remove the opener pull handle.

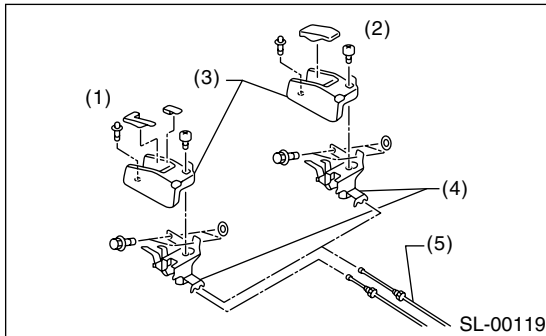

- (1) Sedan
- (2) Wagon
- (3) Cover
- (4) Pull handle ASSY
- (5) Cable

- 4) Remove the cable from opener pull handle.
- 5) Remove the striker from trunk lid.

- 6) Remove the cable from striker.

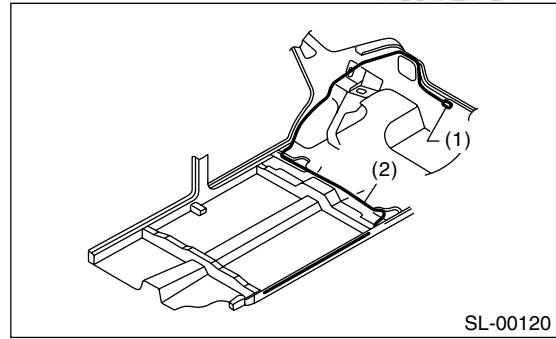

- (1) Striker
- (2) Cable

3. FUEL FLAP OPENER

- 1) Remove the rear seat. <Ref. to SE-16, REMOVAL, Rear Seat.>
- 2) Remove the center pillar lower trim, and remove the side sill cover on passenger side. Remove the rear pillar lower trim. Pull back the floor mat. Remove the clip holding the cable.
- 3) Remove the bolt. Remove the opener pull handle.

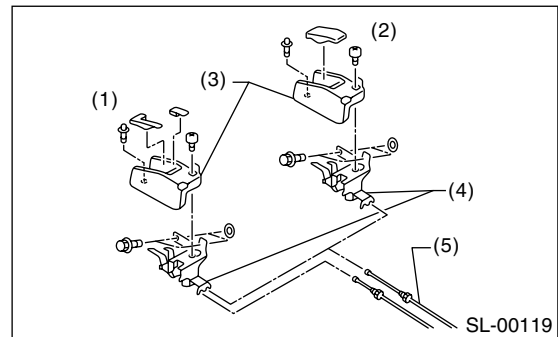

- (1) Sedan
- (2) Wagon
- (3) Cover
- (4) Pull handle ASSY
- (5) Cable

- 4) Remove the cable from opener pull handle.
- 5) Remove the right rear quarter trim. <Ref. to EI-49, REMOVAL, Rear Quarter Trim.>

6) Rotate the fuel lock inside the quarter panel to left and remove.

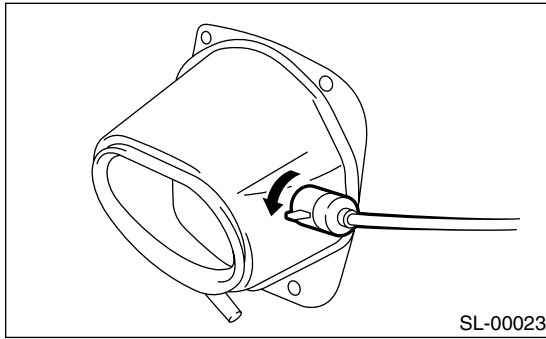

B: INSTALLATION

1. HOOD OPENER

Install in the reverse order of removal.

2. TRUNK LID OPENER

Install in the reverse order of removal.

3. FUEL FLAP OPENER

Install in the reverse order of removal.

C: INSPECTION

Make sure the fuel flap opens and closes smoothly.

Brought to you by Eris Studios
NOT FOR RESALE

20. Ignition Key Lock

A: REPLACEMENT

- 1) Remove the ground cable from battery.
- 2) Remove the steering column. <Ref. to PS-20, REMOVAL, Tilt Steering Column.>
- 3) Secure the steering column in a vise. Remove the bolt with a drill.

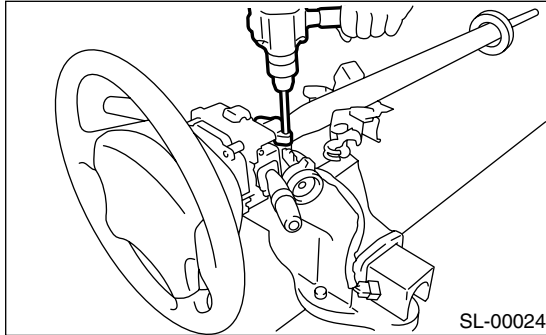

- 4) Remove the ignition key lock.
- 5) Use a new torn bolt. Tighten the torn bolt to end of thread.

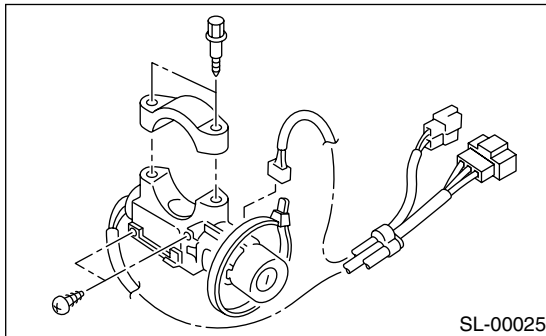

B: INSPECTION

- 1) Remove the instrument panel lower cover.
- 2) Remove the lower column cover.
- 3) Unfasten the hold-down clip which secures harness and disconnect the connector of ignition switch from body harness.
- 4) Turn the ignition key plate to each position and check the continuity between terminals of ignition connector.

Switch position	Terminal No.	Standard
LOCK	—	—
ACC	No. 1 and No. 2	Less than 1 Ω
ON	No. 1 and No. 2 No. 1 and No. 4 No. 2 and No. 4	Less than 1 Ω
ST	No. 1 and No. 3 No. 1 and No. 4 No. 3 and No. 4	Less than 1 Ω

If NG, replace the ignition switch.

21. Key Lock Cylinders

A: REPLACEMENT

1. FRONT DOOR

- 1) Remove the door trim. <Ref. to EI-38, REMOVAL, Front Door Trim.>
- 2) Pull back the sealing cover.
- 3) Move the front door glass downward.
- 4) Remove the rod clamp. Remove the bolt. Replace the key cylinder.

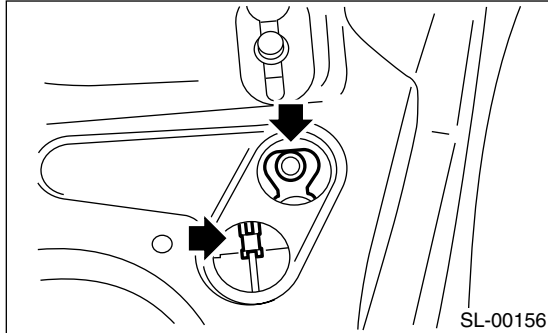

2. TRUNK LID

- 1) Remove the trunk lid release handle. <Ref. to SL-40, Trunk Lid Release Handle.>
- 2) Remove the rod clamp. Remove the lock plate. Replace the key cylinder.

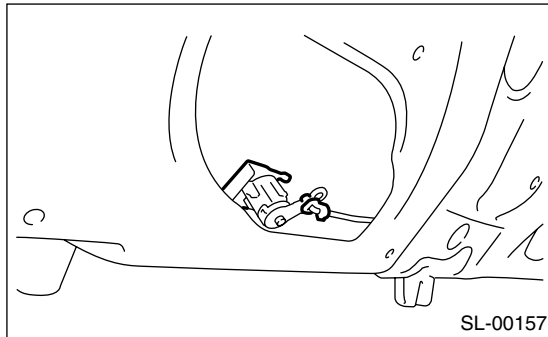

22. Security Control Module

A: REMOVAL

1. EXCEPT STi MODEL

- 1) Disconnect the ground terminal from battery.
- 2) Remove the console cover.

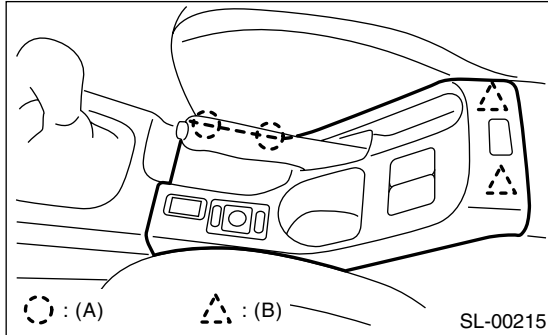

- (A) Hook pawl
- (B) Clip

- 3) Disconnect the connector from the security control module.
- 4) Remove bolt (A) and loosen bolt (B).

NOTE:

Loosen bolt (B) without completely removing it.

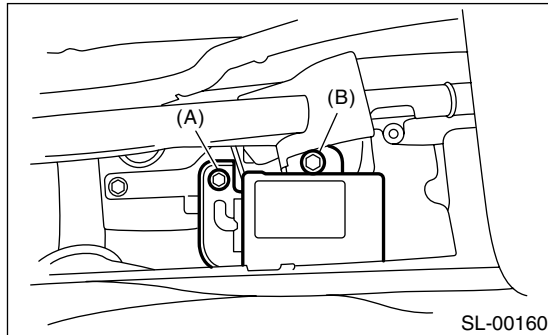

- 5) Remove the security control module.

2. STi MODEL

- 1) Disconnect the ground cable from battery.
- 2) Remove the glove box. <Ref. to EI-40, REMOVAL, Glove Box.>

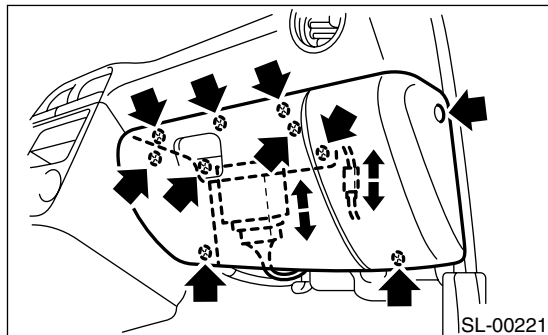

- 3) Remove a bolt (A) and disconnect the connector, and then remove the security control module.

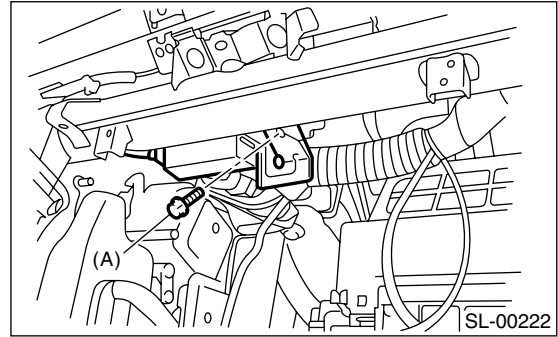

B: INSTALLATION

Install in the reverse order of removal.

NOTE:

To install the security control module, tighten the bolts securely so that the bolts do not come loose.

C: INSPECTION

1. IMPACT SENSITIVITY TEST

- 1) Remove the key from the ignition switch.
- 2) Close all windows.
- 3) Close all doors and the rear gate or trunk lid.
- 4) Cover the hood with a blanket.
- 5) Press the LOCK/ARM button of the transmitter.
- 6) Confirm that the security indicator light blinks every 2 seconds.
- 7) Hit the center of the windshield with your palm and make sure the alarm operates.

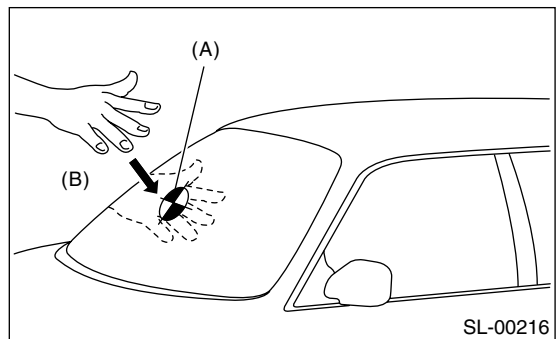

- (A) Center of windshield
- (B) Hit with palm

If NG, adjust the impact sensitivity. <Ref. to SL-47, ADJUSTMENT, Security Control Module.>

D: ADJUSTMENT

1. IMPACT SENSITIVITY

NOTE:

Before adjustment, make sure the security control module has been securely installed on the bracket.

- 1) Remove the security control module. <Ref. to SL-46, REMOVAL, Security Control Module.>
- 2) Adjust the sensitivity adjust screw in the security control module.

NOTE:

After adjusting, be sure to plug the adjust screw hole.

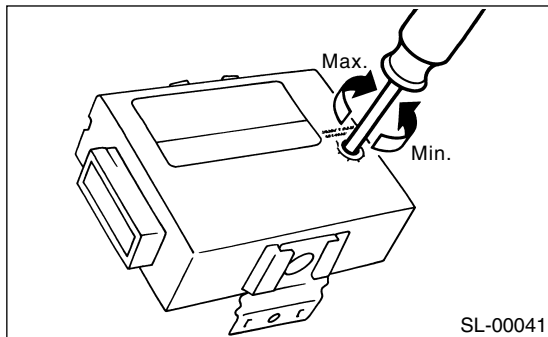

- 3) Install the security control module.
- 4) Perform the impact sensitivity test.

Brought to you by Eris Studios
NOT FOR RESALE

23. Security Horn

A: REMOVAL

- 1) Disconnect the ground terminal from battery.
- 2) Remove the nuts and then detach the security horn while disconnecting the connector.

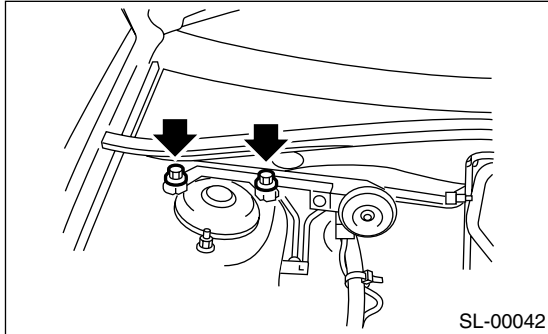

B: INSTALLATION

Install in the reverse order of removal.

C: INSPECTION

Connect the battery to the security horn terminal and case ground and make sure the horn sounds properly.

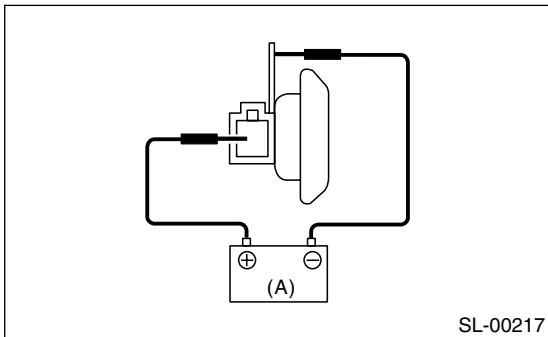

(A) Battery

If NG, replace the security horn.

Brought to you by Eris Studios
NOT FOR RESALE

24. Security Horn Relay

A: REMOVAL

- 1) Disconnect the ground terminal from battery.
- 2) Remove the mounting bolt and detach the security horn relay (near the fuse box).

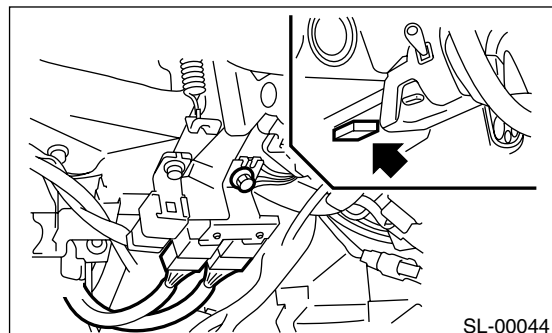

B: INSTALLATION

Install in the reverse order of removal.

C: INSPECTION

Measure the security horn relay resistance between terminals (indicated in the table below) when connecting terminal No. 4 to battery positive terminal and terminal No. 1 to battery ground terminal.

Current	Terminal No.	Standard
Flow	2 and 3	Less than 1 Ω
No flow		More than 1 M Ω

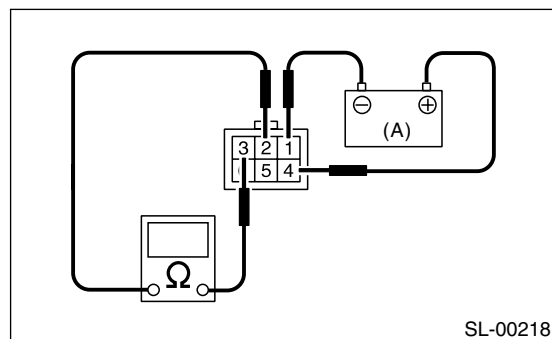

(A) Battery

If NG, replace the security horn relay.

Brought to you by Eris Studios
NOT FOR RESALE

25. Interrupt Relay

A: REMOVAL

- 1) Disconnect the ground terminal from battery.
- 2) Remove the mounting nuts and detach the interrupt relay (near the fuse box).

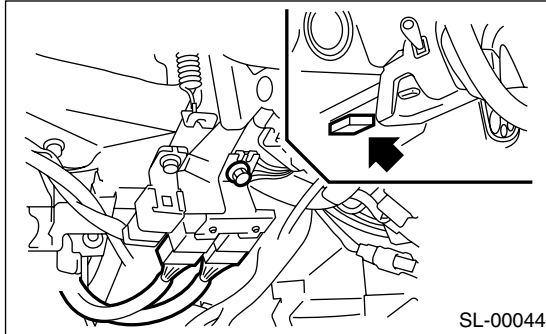

B: INSTALLATION

Install in the reverse order of removal.

C: INSPECTION

Measure the interrupt relay resistance between terminals (indicated in the table below) when connecting terminal No.4 to battery positive terminal and terminal No.1 to battery ground terminal.

Current Flow	Terminal No.	Standard
Flow	2 and 6	Less than 1 Ω
No flow		More than 1 M Ω

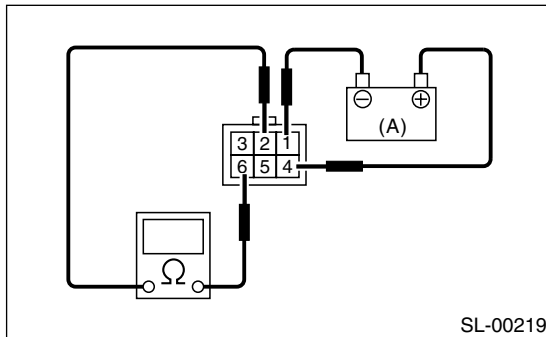

(A) Battery

If NG, replace the interrupt relay.

26. Keyless Entry Control Module

A: REMOVAL

- 1) Disconnect the ground cable from battery.
- 2) Remove the instrument panel lower cover. <Ref. to EI-44, REMOVAL, Instrument Panel Assembly.>
- 3) Remove the nut, and then remove the keyless entry control module while disconnecting connector.

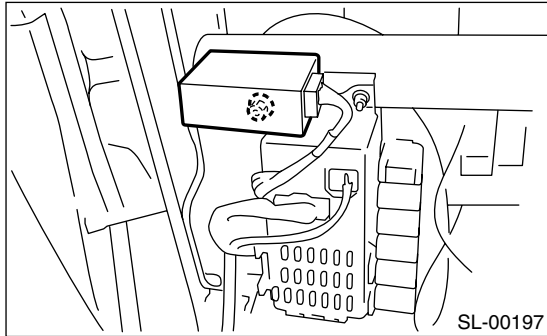

- 4) Disconnect the keyless entry control module and other electrical control module.

B: INSTALLATION

Install in the reverse order of removal.

27. Body Integrated Module

A: REMOVAL

- 1) Disconnect the ground terminal from battery.
- 2) Remove the instrument panel lower cover. <Ref. to EI-44, REMOVAL, Instrument Panel Assembly.>
- 3) Remove the nut, then remove the body integrated module while disconnecting the connector.

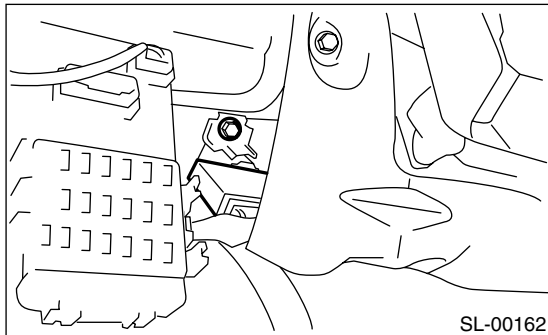

B: INSTALLATION

Install in the reverse order of removal.

28. Keyless Transmitter

A: REMOVAL

1. TRANSMITTER BATTERY

Remove the screw from transmitter, and then remove the battery.

NOTE:

To prevent static electricity damage to transmitter printed circuit board, touch the steel area of building with hand to discharge the static electricity carried on body or clothes before disassembling transmitter.

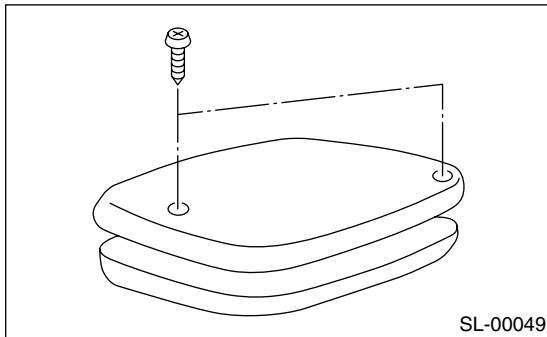

B: INSTALLATION

1. TRANSMITTER BATTERY

Install in the reverse order of removal.

C: INSPECTION

1. TRANSMITTER BATTERY

Measure the voltage between battery (+) terminal and (-) terminal.

NOTE:

- Battery discharge occurs during measurement. Complete the measurement within 5 seconds.
- During battery voltage measurement, voltage falls more than 1.8 volts in 3 seconds period.

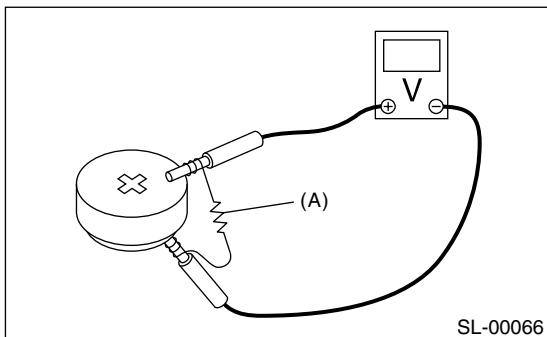

(A) Resistance 47 Ω

Tester connection		Standard
(+)	(-)	
Battery (+) terminal	Battery (-) terminal	2.5 — 3.0 V

If NG, replace the battery. (Use CR1620 or equivalent.)

D: REPLACEMENT

1. TRANSMITTER REGISTRATION

NOTE:

- A maximum of four transmitters can be registered for each individual vehicle.
- When replacing or adding the transmitter (key), registration is also necessary.
- Finish the operation from step 1) through 4) within 45 seconds.

- 1) Sit on the driver's seat and close all doors and rear gate.
- 2) Open the driver's door.
- 3) Close the driver's door.
- 4) Turn the ignition switch from ON to LOCK ten times within 15 seconds.

NOTE:

Do not start the engine at this time.

- 5) The horn chirps one time to indicate that the system has entered in the programming mode.
- 6) Open the driver's door.
- 7) Close the driver's door.
- 8) Press any button on the transmitter that you wish to program into the system.
- 9) Horn will chirp two times to indicate that the transmitter has been programmed.

NOTE:

Repeat steps 6) through 9) for an additional transmitter.

10) Remove the ignition key from the ignition switch.

11) The horn will chirp three times to indicate that the system has exited the programming mode.

12) Check the keyless entry system properly operates by operating each transmitter.

KEYLESS TRANSMITTER

Brought to you by Eris Studios
NOT FOR RESALE