

Brought to you by Eris Studios
NOT FOR RESALE

FRONT SUSPENSION

GENERAL DESCRIPTION

FRONT SUSPENSION

1. General Description

A: SPECIFICATIONS

	Model	Sedan			Wagon		OUT- BACK
		Non-turbo	Turbo	STi	Non-turbo	Turbo	
Front	Camber (tolerance: $\pm 0^{\circ}45'$)	$-0^{\circ}15'$	$-0^{\circ}25'$	$-0^{\circ}30'$	$-0^{\circ}10'$	$-0^{\circ}20'$	$-0^{\circ}05'$
	Caster (common difference: $\pm 0^{\circ}45'$)	$3^{\circ}25'$	$3^{\circ}35'$	$4^{\circ}50'$	$3^{\circ}25'$	$3^{\circ}35'$	$3^{\circ}25'$
	Toe-in	0 ± 3 mm (0 ± 0.12 in) Each toe angle: $\pm 0^{\circ}07'30''$					
	Kingpin angle (tolerance: $\pm 0^{\circ}45'$)	$14^{\circ}20'$	$14^{\circ}35'$	$14^{\circ}50'$	$13^{\circ}30'$	$13^{\circ}45'$	$13^{\circ}20'$
	Wheel arch height [tolerance: ± 12 mm (± 0.47 in)]	406 mm (15.98 in)	396 mm (15.59 in)	386 mm (15.20 in)	397 mm (15.28 in)	387 mm (15.24 in)	402 mm (15.83 in)
	Diameter of stabilizer	20 mm (0.79 in)	20 mm (0.79 in)	19 mm (0.75 in)	20 mm (0.79 in)	20 mm (0.79 in)	20 mm (0.79 in)
Rear	Camber (tolerance: $\pm 0^{\circ}45'$)	$-1^{\circ}25'$	$-1^{\circ}30'$	$-0^{\circ}40'$	$-1^{\circ}15'$	$-1^{\circ}20'$	$-1^{\circ}10'$
	Toe-in	0 ± 3 mm (0 ± 0.12 in) Each toe angle: $\pm 0^{\circ}09'$					
	Thrust angle	$0^{\circ} \pm 30'$					
	Wheel arch height [tolerance: ± 12 mm (± 0.47 in)]	381 mm (15.0 in)	376 mm (14.80 in)	366 mm (14.41 in)	381 mm (15.0 in)	376 mm (14.80 in)	386 mm (15.20 in)
	Diameter of stabilizer	13 mm (0.51 in)	17 mm (0.67 in)	20 mm (0.79 in)	13 mm (0.51 in)	17 mm (0.67 in)	13 mm (0.51 in)

NOTE:

- Front and rear toe-ins and front camber can be adjusted. If toe-in or camber tolerance exceeds specifications, adjust toe-in and camber to the middle value of specification.
- The other items indicated in the specification table cannot be adjusted. If the other items exceeds specifications, check suspension parts and connections for deformities; replace with new ones as required.

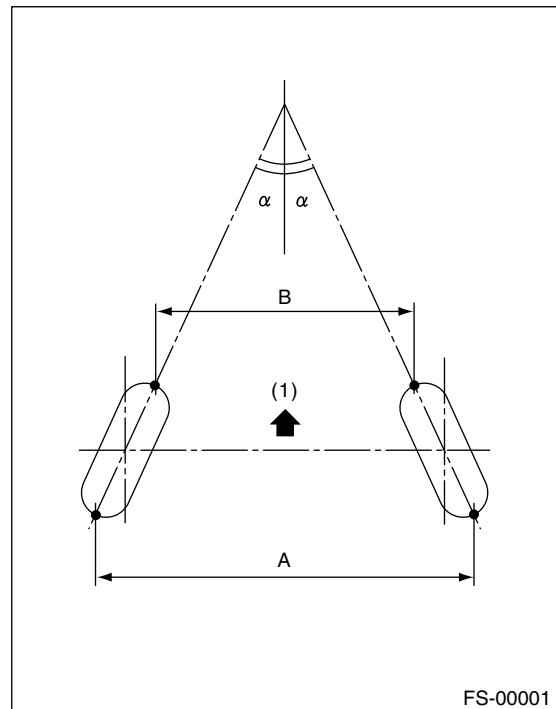

(1) Front

A – B = Positive: Toe-in, Negative: Toe-out

α = Each toe angle

GENERAL DESCRIPTION

FRONT SUSPENSION

B: COMPONENT

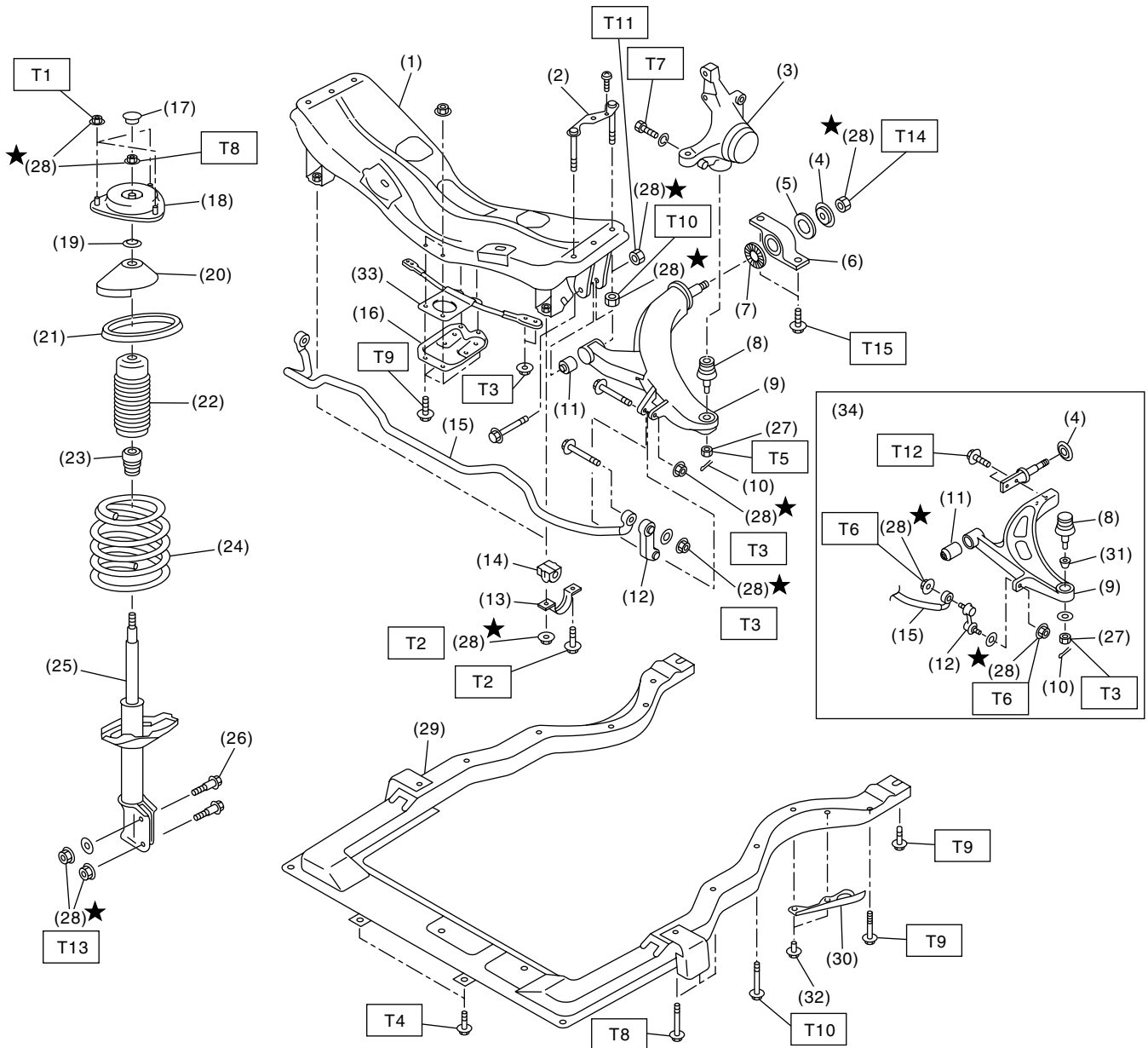

FS-00093

GENERAL DESCRIPTION

FRONT SUSPENSION

(1) Front crossmember	(18) Strut mount	Tightening torque: N·m (kgf-m, ft-lb)
(2) Bolt ASSY	(19) Spacer	T1: 20 (2.0, 14.5)
(3) Housing	(20) Upper spring seat	T2: 25 (2.5, 18.1)
(4) Washer	(21) Rubber seat	T3: 30 (3.1, 22)
(5) Stopper rubber (Rear)	(22) Dust cover	T4: 34 (3.5, 25)
(6) Rear bushing	(23) Helper	T5: 40 (4.1, 30)
(7) Stopper rubber (Front)	(24) Coil spring	T6: 45 (4.6, 33)
(8) Ball joint	(25) Damper strut	T7: 50 (5.1, 37)
(9) Transverse link	(26) Adjusting bolt	T8: 55 (5.6, 41)
(10) Cotter pin	(27) Castle nut	T9: 70 (7.1, 52)
(11) Front bushing	(28) Self-locking nut	T10: 105 (10.7, 77)
(12) Stabilizer link	(29) Sub frame	T11: 125 (12.7, 92)
(13) Clamp	(30) Cover	T12: 155 (15.8, 114)
(14) Bushing	(31) Boss	T13: 175 (17.8, 129)
(15) Stabilizer	(32) Clip	T14: 190 (19.4, 140)
(16) Jack-up plate	(33) Front support arm	T15: 250 (25.5, 184)
(17) Dust seal	(34) STi model	

C: CAUTION

- Wear working clothing, including a cap, protective goggles, and protective shoes during operation.
- Before removal, installation or disassembly, be sure to clarify the failure. Avoid unnecessary removal, installation, disassembly, and replacement.
- Use SUBARU genuine grease etc. or the equivalent. Do not mix grease etc. with that of another grade or from other manufacturers.
- Before securing a part on a vise, place cushioning material such as wood blocks, aluminum plate, or shop cloth between the part and the vise.
- Be sure to tighten fasteners including bolts and nuts to the specified torque.
- Place shop jacks or safety stands at the specified points.

GENERAL DESCRIPTION

FRONT SUSPENSION

D: PREPARATION TOOL

1. SPECIAL TOOLS

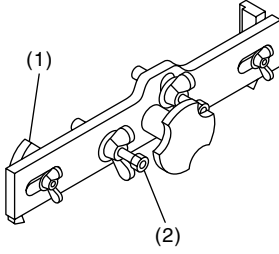
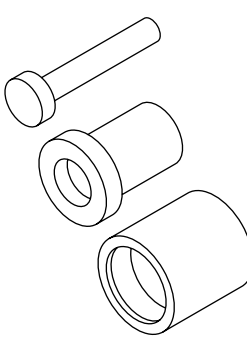
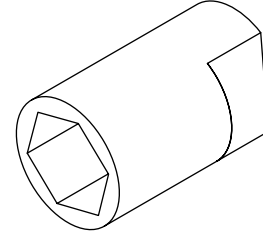
ILLUSTRATION	TOOL NUMBER	DESCRIPTION	REMARKS
 <p>ST-927380002</p>	927380002	ADAPTER	Used as an adapter for camber & caster gauge when measuring camber and caster. (1) 28199AC000 PLATE (2) 28199AC010 BOLT
 <p>ST-927680000</p>	927680000	INSTALLER & REMOVER SET	Used for replacing transverse link bushing.
 <p>ST-927760000</p>	927760000	STRUT MOUNT SOCKET	Used for disassembling and assembling strut and shock mount.

2. GENERAL PURPOSE TOOLS

TOOL NAME	REMARKS
Alignment gauge	Used for wheel alignment measurement.
Turning radius gauge	Used for wheel alignment measurement.
Toe-in gauge	Used for toe-in measurement.
Dial gauge	Used for damper strut measurement.
Coil spring compressor	Used for strut disassembly/assembly.

Brought to you by Eris Studios
NOT FOR RESALE

2. Wheel Alignment

A: INSPECTION

Check the following items before taking wheel alignment measurement.

Check items before taking wheel alignment measurement:

- tire air pressure
- unbalanced right and left tire wear, size difference
- tire run-out
- ball joint excessive play, wear
- tie rod end excessive play, wear
- wheel bearing excessive play
- right and left wheel base imbalance
- steering link part deformed, excessive play
- suspension part deformed, excessive play

Check, adjust and/or measure the wheel alignment in accordance with procedures indicated in the figure:

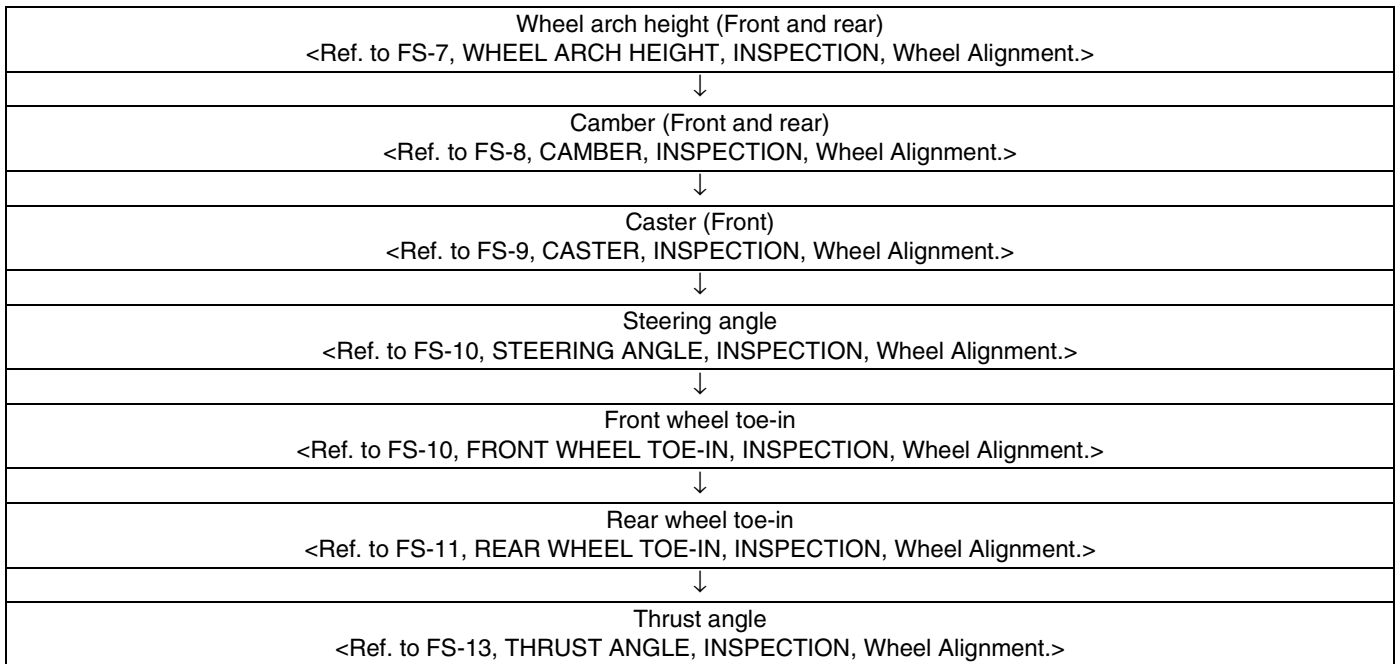

WHEEL ALIGNMENT

FRONT SUSPENSION

1. WHEEL ARCH HEIGHT

- 1) Set the vehicle on a level surface.
- 2) Set the vehicle to "curb weight" conditions. (Empty luggage compartment, install spare tire, jack, service tools, and top up fuel tank.)
- 3) Set the steering wheel in a straight line, then remove the vehicle straight ahead more than 5 m (16 ft) to settle the suspension.
- 4) Suspend the thread from wheel arch (point "A" in figure below) to determine a point directly above center of wheel.
- 5) Measure the distance between measuring point "A" and center of wheel.

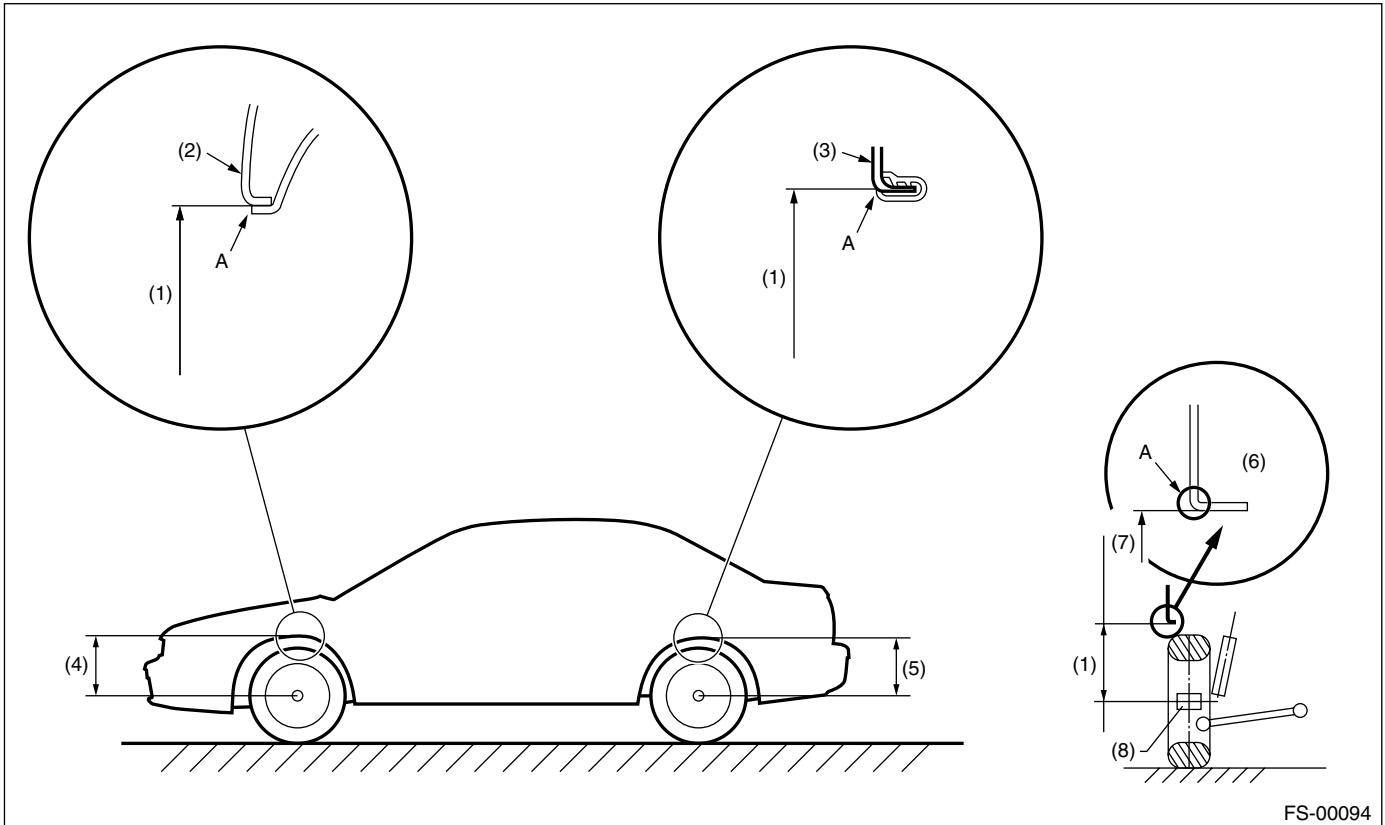

FS-00094

- | | | |
|-----------------------|-----------------------------|---------------------|
| (1) Wheel arch height | (4) Front wheel arch height | (7) Measuring point |
| (2) Front fender | (5) Rear wheel arch height | (8) End of spindle |
| (3) Rear quarter | (6) Flange bend line | |

Model		Specified wheel arch height	
		Non-turbo	Turbo
Sedan	Front	406±12 mm (15.98±0.47 in)	396±12 mm (15.59±0.47 in)
	Rear	381±12 mm (15.0±0.47 in)	376±12 mm (14.80±0.47 in)
Wagon	Front	397±12 mm (15.63±0.47 in)	387±12 mm (15.24±0.47 in)
	Rear	381±12 mm (15.0±0.47 in)	376±12 mm (14.80±0.47 in)
OUTBACK	Front	402±12 mm (15.83±0.47 in)	—
	Rear	386±12 mm (15.20±0.47 in)	—
STi	Front	—	386±12 mm (15.20±0.47 in)
	Rear	—	366±12 mm (14.41±0.47 in)

WHEEL ALIGNMENT

FRONT SUSPENSION

2. CAMBER

• Inspection

- 1) Place the front wheel on turning radius gauge. Make sure ground contacting surfaces of front and rear wheels are set at the same height.
- 2) Set the ST into the center of wheel, and then install the wheel alignment gauge.
ST 927380002 ADAPTER

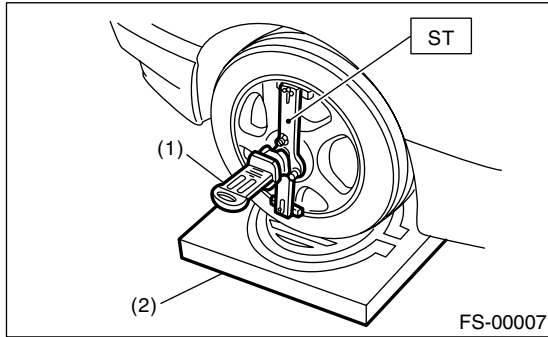

- (1) Alignment gauge
- (2) Turning radius gauge

- 3) Follow the wheel alignment gauge operation manual to measure camber angle.

NOTE:

Refer to the "SPECIFICATIONS" for camber values.

Front: <Ref. to FS-2, SPECIFICATIONS, General Description.>

Rear: <Ref. to RS-2, SPECIFICATIONS, General Description.>

• Front Camber Adjustment

- 1) Loosen the two self-locking nuts located at lower front portion of strut.

NOTE:

When adjusting bolt needs to be loosened or tightened, hold its head with a wrench and turn self-locking nut.

- 2) Turn the camber adjusting bolt so that camber is set at the specification.

NOTE:

Moving the adjusting bolt by one scale graduation changes camber by approx. $0^{\circ}10'$.

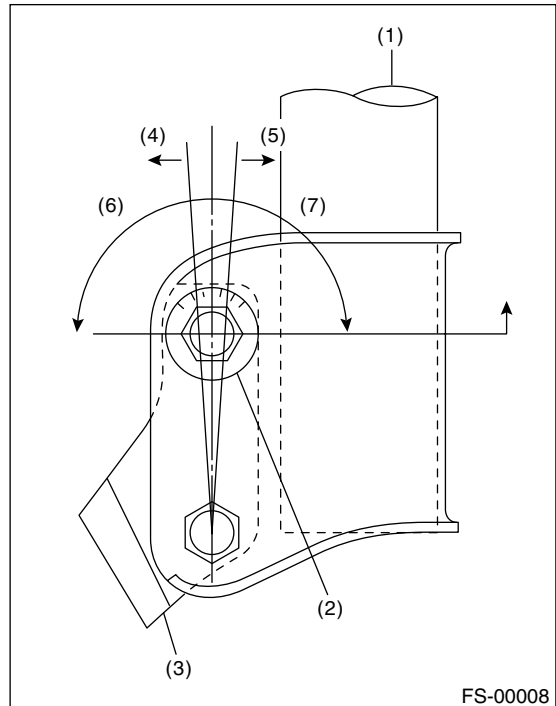

- (1) Strut
- (2) Adjusting bolt
- (3) Housing
- (4) Outer
- (5) Inner
- (6) Camber is increased.
- (7) Camber is decreased.

WHEEL ALIGNMENT

FRONT SUSPENSION

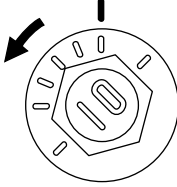
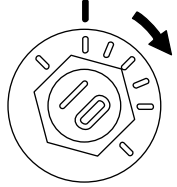
Camber is increased.	
Rotate camber adjusting bolt LH counterclockwise.	Rotate camber adjusting bolt RH clockwise.
 <p style="text-align: right;">FS-00009</p>	 <p style="text-align: right;">FS-00010</p>

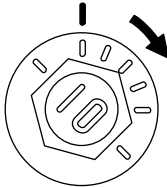
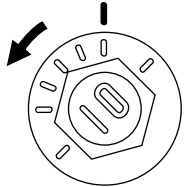
Camber is decreased.	
Rotate camber adjusting bolt LH clockwise.	Rotate camber adjusting bolt RH counterclockwise.
 <p style="text-align: right;">FS-00010</p>	 <p style="text-align: right;">FS-00009</p>

3) Tighten the new two self-locking nuts.

Tightening torque:

175 N·m (17.8 kgf·m, 129 ft·lb)

3. CASTER

• **Inspection**

- 1) Place the front wheel on turning radius gauge. Make sure ground contacting surfaces of front and rear wheels are set at the same height.
- 2) Set the ST into center of wheel, and then install the wheel alignment gauge.

ST 927380002 ADAPTER

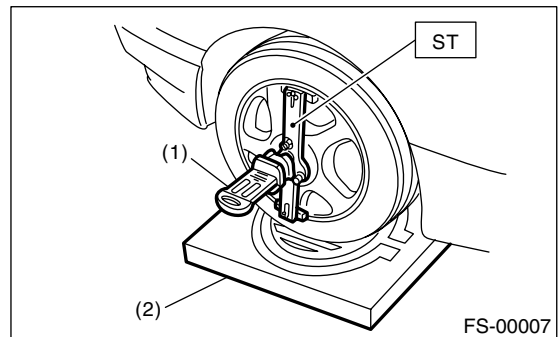

- (1) Alignment gauge
- (2) Turning radius gauge

3) Follow the wheel alignment gauge operation manual to measure caster angle.

NOTE:

Refer to the "SPECIFICATIONS" for caster values.
<Ref. to FS-2, SPECIFICATIONS, General Description.>

WHEEL ALIGNMENT

FRONT SUSPENSION

4. STEERING ANGLE

• Inspection

- 1) Place the vehicle on a turning radius gauge.
- 2) While depressing the brake pedal, turn the steering wheel fully to the right and left. With the steering wheel held at each fully turned position, measure both the inner and outer wheel steering angle.

Steering angle:

Model	Turbo and OUTBACK	Others
Inner wheel	34.5°±1.5°	37.3°±1.5°
Outer wheel	30.3°±1.5°	32.4°±1.5°

• Adjustment

- 1) Turn the tie-rod to adjust steering angle of both inner and outer wheels.
- 2) Check the toe-in.

NOTE:

Correct the boot if it is twisted.

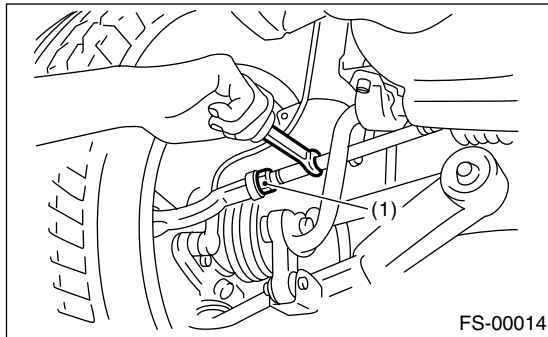

(1) Lock nut

5. FRONT WHEEL TOE-IN

• Inspection

Toe-in:

0±3 mm (0±0.12 in)

- 1) Set the toe-in gauge to rear sides of right and left front tires at height corresponding to center of spindle.
- 2) Mark each right and left tires at height corresponding to center of spindle and measure the distance "A" between marks.
- 3) Move the vehicle forward to rotate wheels 180°.

NOTE:

Whenever rotating the wheels, drive the vehicle forward.

- 4) Measure the distance "B" between right and left marks. Toe-in can then be obtained by the following equation:

$$A - B = \text{Toe-in}$$

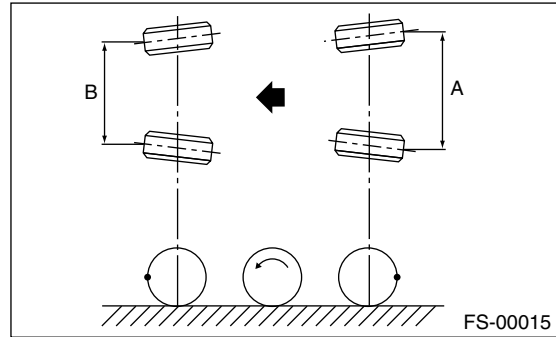

• Adjustment

- 1) Make sure that the right and left steering angles are within specified value.
- 2) Loosen the right and left side steering tie-rod lock nuts.
- 3) Turn the right and left tie rods equal amounts until the toe-in is at the specification. Both the right and left tie-rods are right-hand threaded. To increase toe-in, turn both tie-rods clockwise equal amounts (as viewed from inside of the vehicle).

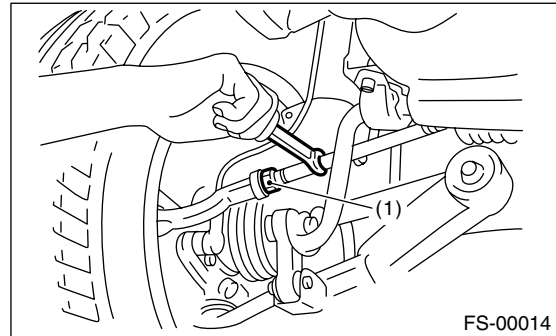

(1) Lock nut

- 4) Tighten the tie-rod lock nut.

Tightening torque:

83 N·m (8.5 kgf-m, 61.5 ft-lb)

NOTE:

Correct the tie-rod boot, if it is twisted.

6. REAR WHEEL TOE-IN

• Inspection

Toe-in:

0 ± 3 mm (0 ± 0.12 in)

For rear toe-in inspection procedure, refer to FRONT WHEEL TOE-IN procedure.

<Ref. to FS-10, FRONT WHEEL TOE-IN, INSPECTION, Wheel Alignment.>

• Adjustment

1) Loosen the self-locking nut on inner side of link rear.

NOTE:

When loosening or tightening the adjusting bolt, hold the bolt head and turn self-locking nut.

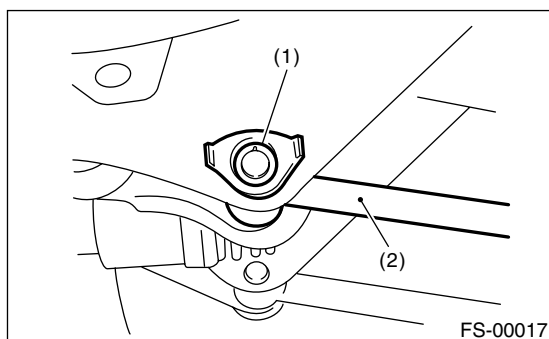

- (1) Adjusting bolt
- (2) Link rear

2) Turn the adjusting bolt head until toe-in is at the specification.

NOTE:

When the right and left wheels are adjusted for toe-in at the same time, the movement of one scale graduation changes toe-in by approx. 1.5 mm (0.6 in).

WHEEL ALIGNMENT

FRONT SUSPENSION

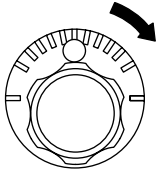
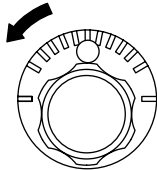
Toe-in is increased.	
Rotate camber adjusting bolt LH clockwise.	Rotate camber adjusting bolt RH counterclockwise.
	
FS-00018	FS-00019

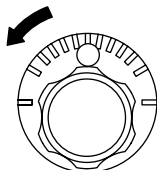
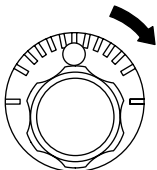
Toe-in is decreased.	
Rotate camber adjusting bolt LH counterclockwise.	Rotate camber adjusting bolt RH clockwise.
	
FS-00019	FS-00018

3) Tighten a new self-locking nut.

Tightening torque:

100 N·m (10.2 kgf·m, 74 ft·lb)

7. THRUST ANGLE

• Inspection

- 1) Position the vehicle on a level surface.
- 2) Move the vehicle 3 to 4 m (10 to 13 ft) directly forward.
- 3) Determine the center lines of loci of both front and rear axles.
- 4) Measure the distance "L" between center lines of loci of the axles.

Thrust angle:

Less than 30' when "L" is less than 22 mm (0.9 in).

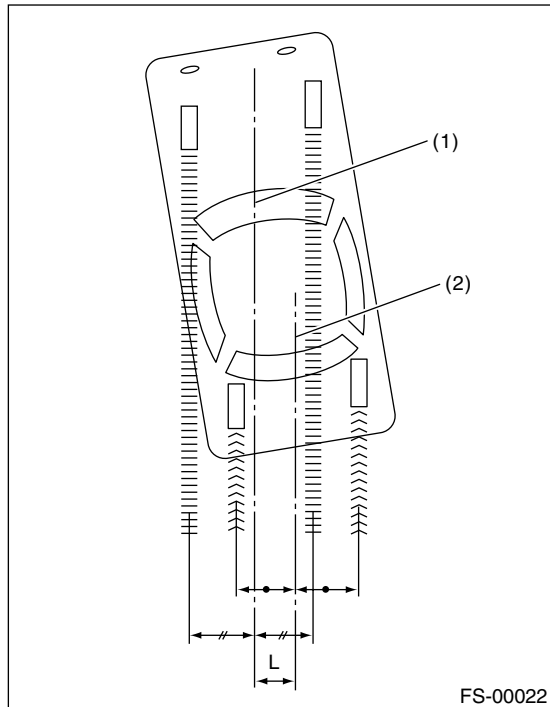

- (1) Center line of loci (front axle)
- (2) Center line of loci (rear axle)

• Adjustment

- 1) Make the thrust angle adjustments by turning toe-in adjusting bolts of rear suspension equally in the same direction.
- 2) When one rear wheel is adjusted in a toe-in direction, adjust the other rear wheel equally in toe-out direction, in order to make thrust angle adjustment.
- 3) When the right and left adjusting bolts are turned incrementally by one graduation in the same direction, the thrust angle will change approx. 16' ["L" is almost equal to 12 mm (0.472 in)].

Thrust angle:

0°±30'

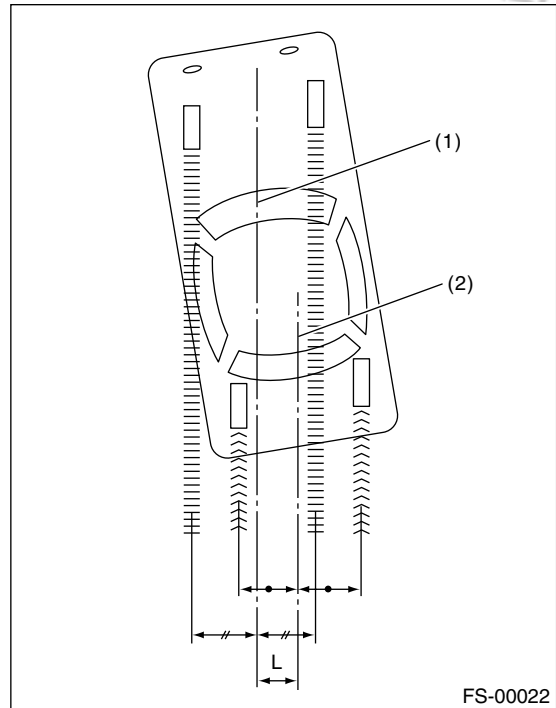

- (1) Center line of loci (front axle)
- (2) Center line of loci (rear axle)

NOTE:

Thrust angle refers to a mean value of right and left rear wheel toe angles in relation to the vehicle body center line. Vehicle is driven straight in the thrust angle direction while swinging in the oblique direction depending on the degree of the mean thrust angle.

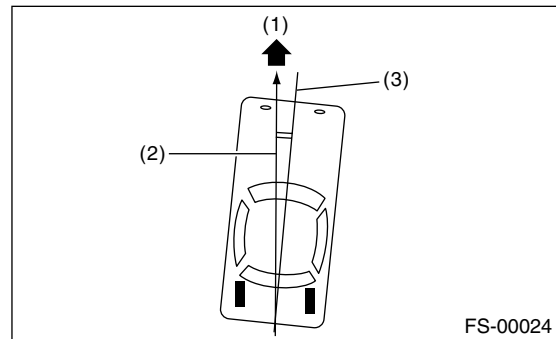

- (1) Front
- (2) Thrust angle
- (3) Body center line

Thrust angle: $r = (\alpha - \beta)/2$

α : Right rear wheel toe-in angle
 β : Left rear wheel toe-in angle

WHEEL ALIGNMENT

FRONT SUSPENSION

Here, use only positive toe-in values from each wheel to substitute for α and β in the equation.

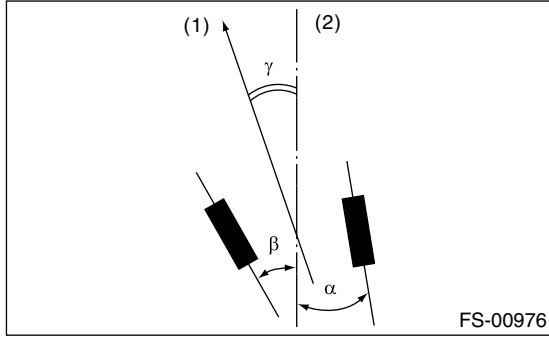

- (1) Front
- (2) Body center line

3. Front Transverse Link

A: REMOVAL

- 1) Set the vehicle on a lift.
- 2) Lift-up the vehicle and remove the wheel.
- 3) Remove the sub frame.
- 4) Disconnect the stabilizer link from transverse link.
- 5) Remove the bolt securing ball joint of transverse link to housing.

SEDAN MODEL:

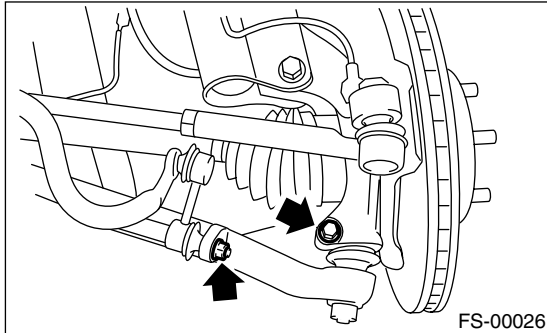

FS-00026

WAGON MODEL:

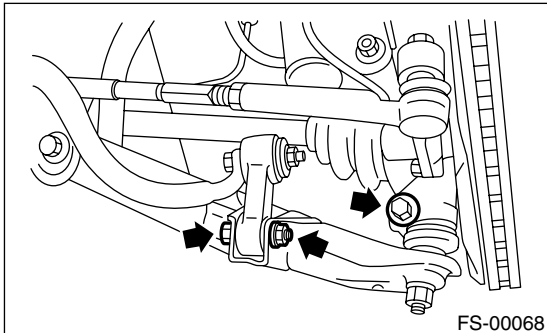

FS-00068

- 6) Remove the nut (do not remove bolt) securing transverse link to crossmember.
- 7) Remove the two bolts securing bushing bracket of transverse link to the vehicle body at rear bushing location.

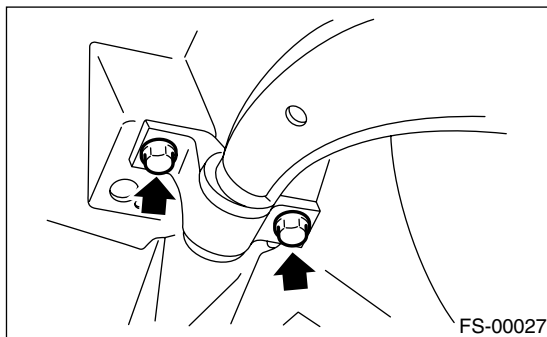

FS-00027

- 8) Extract the ball joint from housing.

- 9) Remove the bolt securing transverse link to crossmember, and then extract the transverse link from crossmember.

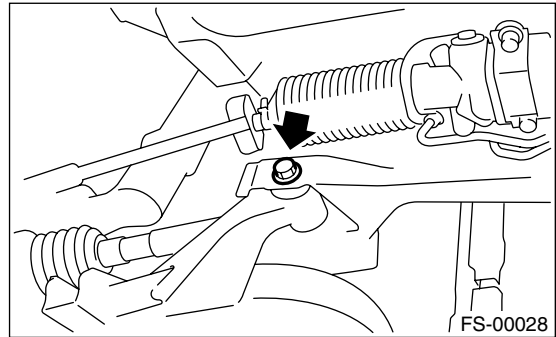

FS-00028

B: INSTALLATION

- 1) Temporarily tighten the two bolts used to secure rear bushing of transverse link to body.

NOTE:

These bolts should be tightened to such an extent that they can still move back and forth in the oblong shaped hole in the bracket (which holds the bushing).

- 2) Install the bolts used to connect transverse link to crossmember and temporarily tighten with a new self-locking nut.

CAUTION:

Discard the loosened self-locking nut and replace with a new one.

- 3) Insert the ball joint into housing.
- 4) Connect the stabilizer link to transverse link, and then temporarily tighten a new self-locking nut.

SEDAN MODEL:

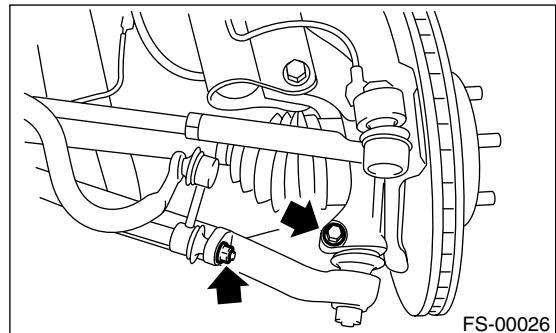

FS-00026

WAGON MODEL:

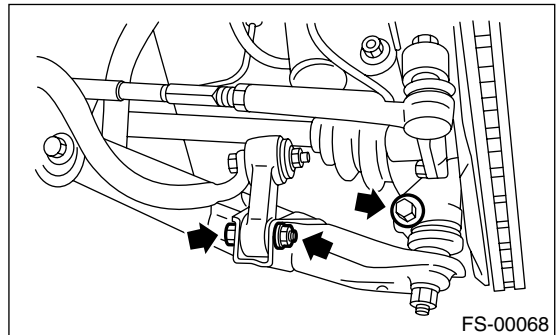

FS-00068

FRONT TRANSVERSE LINK

FRONT SUSPENSION

5) Tighten the following points in the order shown below when tires are in full contact with the ground and vehicle is curb weight.

- (1) Transverse link and stabilizer

Tightening torque:

STi model:

45 N·m (4.6 kgf-m, 33 ft-lb)

Except STi model:

30 N·m (3.1 kgf-m, 22 ft-lb)

- (2) Transverse link and crossmember

Tightening torque:

125 N·m (12.7 kgf-m, 92 ft-lb)

- (3) Transverse link rear bushing and body

Tightening torque:

250 N·m (25.5 kgf-m, 184 ft-lb)

NOTE:

Move the rear bushing back and forth until transverse link-to-rear bushing clearance is established (as indicated in the figure) before tightening. (Except STi model)

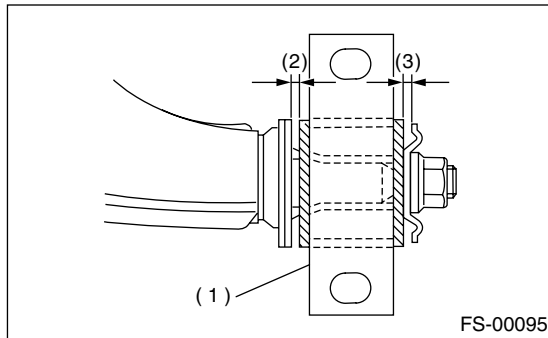

- (1) Rear bushing
- (2) 1 mm (0.04 in)
- (3) 1.5 mm (0.059 in)

6) Check the wheel alignment and adjust if necessary.

C: DISASSEMBLY

1. FRONT BUSHING

Using the ST, press the front bushing out of place.

ST 927680000 INSTALLER & REMOVER SET

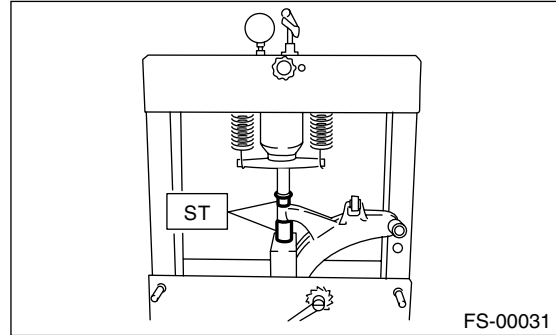

2. REAR BUSHING

- 1) Scribe an aligning mark on the transverse link and rear bushing.
- 2) Loosen the nut, and then remove the rear bushing.

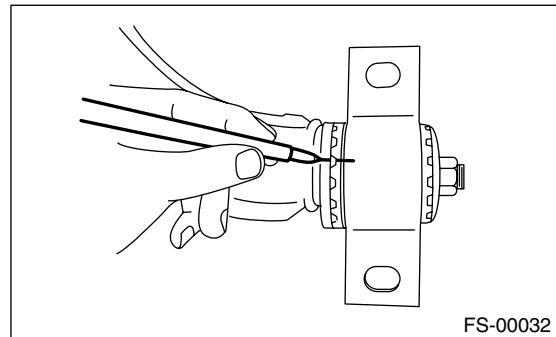

D: ASSEMBLY

1. FRONT BUSHING

Assemble in the reverse order of disassembly.

CAUTION:

Install the front bushing in correct direction, as shown in the figure.

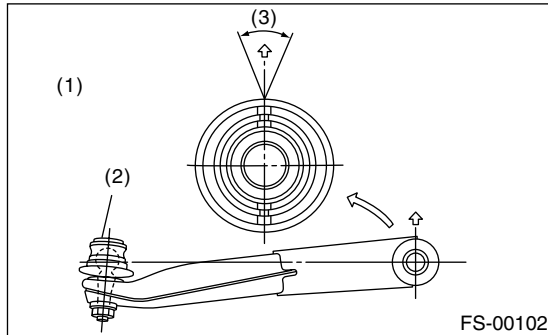

- (1) Face bushing toward center of ball joint
- (2) Ball joint
- (3) $\pm 3^\circ$

2. REAR BUSHING

- 1) Install the rear bushing to transverse link, and then align the aligning marks scribed on the two.
- 2) Tighten the new self-locking nut.

NOTE:

While holding the rear bushing so as not to change position of aligning marks, tighten the self-locking nut.

Tightening torque:

190 N·m (19.4 kgf·m, 140 ft·lb)

E: INSPECTION

- 1) Check the transverse link for wear, damage and cracks, and correct or replace if defective.
- 2) Check the bushings for cracks, fatigue or damage.
- 3) Check the rear bushing for oil leaks.

4. Front Ball Joint

A: REMOVAL

- 1) Remove the wheel.
- 2) Pull out the cotter pin from ball stud, remove the castle nut, and extract the ball stud from transverse link.
- 3) Remove the bolt securing ball joint to housing.

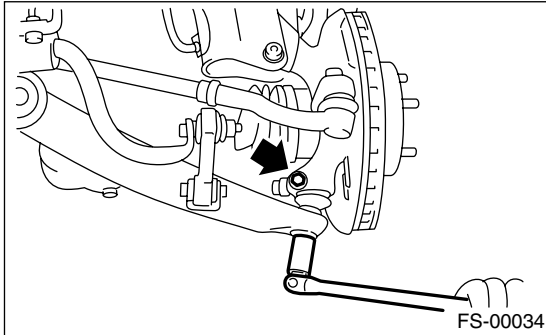

- 4) Extract the ball joint from housing.

B: INSTALLATION

- 1) Install the ball joint onto housing.

Tightening torque (Bolt):

50 N·m (5.1 kgf·m, 37 ft·lb)

CAUTION:

Do not apply grease to tapered portion of ball stud.

- 2) Connect the ball joint to transverse link.

Tightening torque (Castle nut):

STi model:

30 N·m (3.1 kgf·m, 22 ft·lb)

Except STi model:

40 N·m (4.1 kgf·m, 30 ft·lb)

- 3) Retighten the castle nut further within 60° until a slot in castle nut is aligned with the hole in ball stud end, then insert a new cotter pin and bend it around castle nut.

- 4) Install the front wheel.

C: INSPECTION

- 1) Measure the play of ball joint by the following procedures. Replace with a new one when the play exceeds specified value.

- (1) With 686 N (70 kgf, 154 lb) loaded in direction shown in the figure, measure the dimension l_1 .

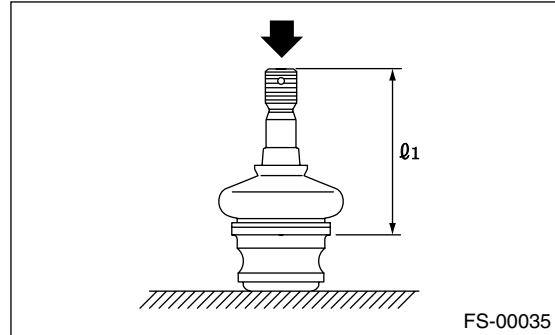

- (2) With 686 N (70 kgf, 154 lb) loaded in opposite direction shown in the figure, measure the dimension l_2 .

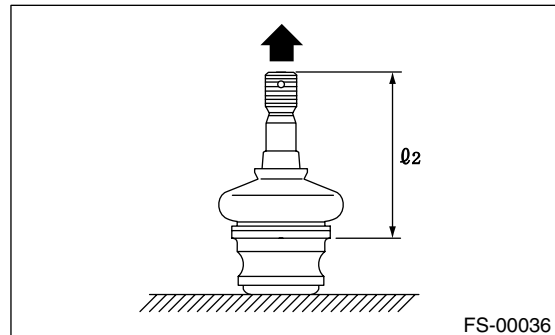

- (3) Calculate plays from the following formula.

$$S = l_2 - l_1$$

- (4) When plays are larger than the following value, replace with a new one.

FRONT BALL JOINT

Specified play for replacement: S

Less than 0.3 mm (0.012 in)

- 2) When the play is smaller than specified value, visually inspect the dust cover.
- 3) The ball joint and cover that have been removed must be checked for wear, damage or cracks, and any defective part must be replaced.
- 4) If the dust cover is damaged, replace with a new ball joint.

5. Front Strut

A: REMOVAL

- 1) Remove the wheel.
- 2) Remove the bolt securing the brake hose from strut.

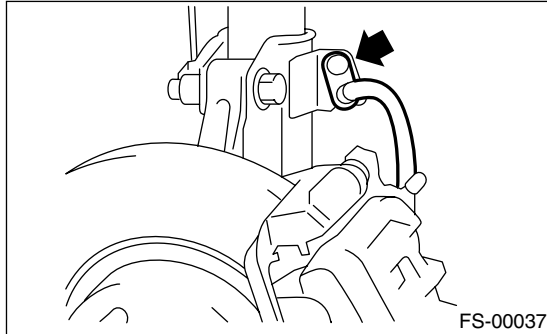

- 3) Scribe an alignment mark on the camber adjusting bolt which secures the strut to housing.
- 4) Remove the bolt securing ABS wheel speed sensor harness.

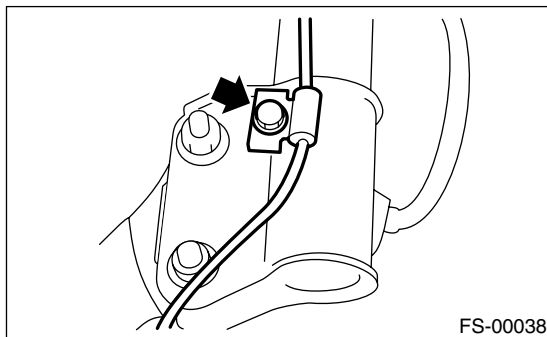

- 5) Remove the two bolts securing housing to strut.

NOTE:

While holding the head of adjusting bolt, loosen self-locking nut.

- 6) Remove the three nuts securing the strut mount to body.

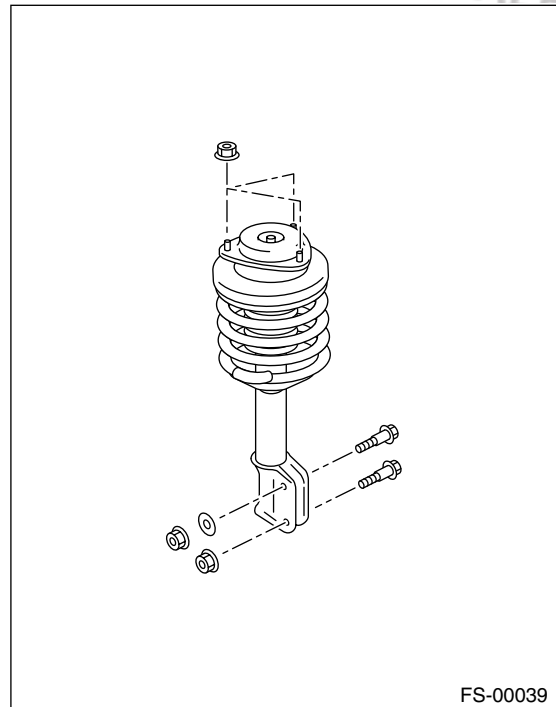

B: INSTALLATION

- 1) Install the strut mount at upper side of strut to body, and then tighten with the nuts.

Tightening torque:

20 N·m (2.0 kgf-m, 14.5 ft-lb)

- 2) Position the aligning mark on camber adjustment bolt with aligning mark on lower side of strut. Install the strut to housing with a new self-locking nut.

NOTE:

While holding the head of adjusting bolt, tighten the self-locking nut.

Tightening torque:

175 N·m (17.8 kgf-m, 129 ft-lb)

- 3) Install the ABS wheel speed sensor harness to strut.

Tightening torque:

33 N·m (3.4 kgf-m, 24.3 ft-lb)

- 4) Install the bolts which secure the brake hose to strut.

Tightening torque:

32 N·m (3.3 kgf-m, 23.6 ft-lb)

- 5) Install the wheels.

NOTE:

Check the wheel alignment and adjust if necessary.

FRONT STRUT

FRONT SUSPENSION

C: DISASSEMBLY

1) Using a coil spring compressor, compress the coil spring.

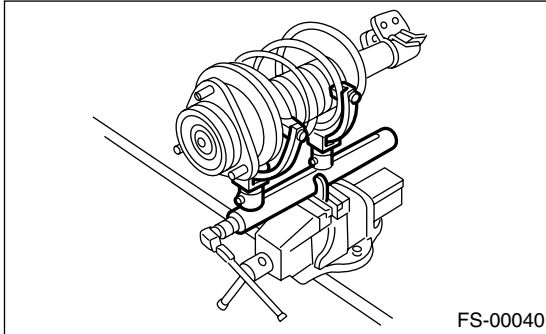

2) Using the ST, remove the self-locking nut.
ST 927760000 STRUT MOUNT SOCKET

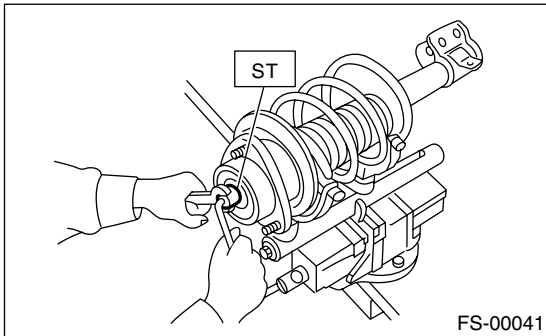

3) Remove the strut mount, upper spring seat and rubber seat from strut.
4) Gradually decreasing the compression force of compressor, and then remove the coil spring.
5) Remove the dust cover and helper spring.

D: ASSEMBLY

1) Before installing the coil spring, strut mount, etc., on strut, check for the presence of air in the damping force generating mechanism of strut since air prevents proper damping force from being produced.

2) Checking for the presence of air

- (1) Place the strut vertically with piston rod facing up.
- (2) Move the piston rod to center of its entire stroke.
- (3) While holding the piston rod end with fingertips, move the rod up and down.
- (4) If the piston rod moves at least 10 mm (0.39 in) in the former step, purge air from the strut.

3) Air purging procedure

- (1) Place the strut vertically with piston rod facing up.
- (2) Fully extend the piston rod.
- (3) With the piston rod fully extended, place the piston rod side down. The strut must stand vertically.

- (4) Fully contract the piston rod.
- (5) Repeat three or four times from first step.

NOTE:

After completely purging air from strut, be sure to place the strut with piston rod facing up. If it is laid down, check for entry of air in the strut as outlined under "Checking for the presence of air".

4) Using a coil spring compressor, compress the coil spring.

NOTE:

Make sure that the installing direction of coil spring is as shown in the figure.

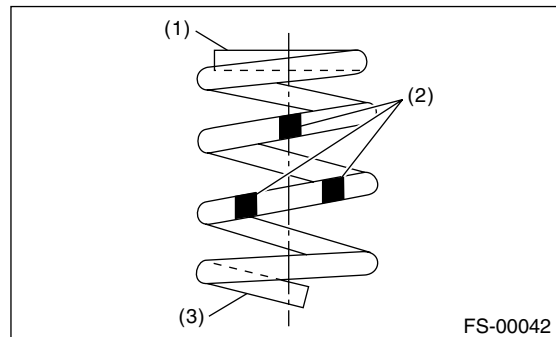

- (1) Flat (top side)
- (2) Identification paint
- (3) Inclined (bottom side)

5) Set the coil spring correctly so that its end face fits well into the spring seat as shown in the figure.

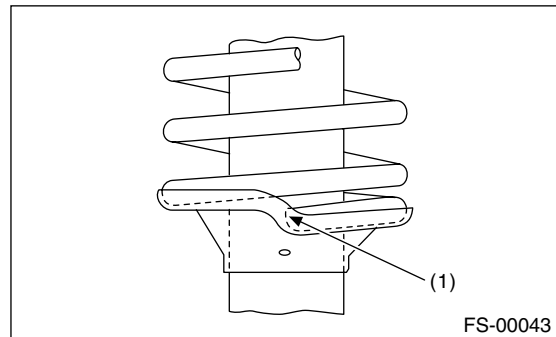

- (1) Coil spring end face

6) Install the helper and dust cover to the piston rod.

7) Pull the piston rod fully upward, and install the rubber seat and spring seat.

NOTE:

Ensure that the upper spring seat is positioned as shown in the figure.

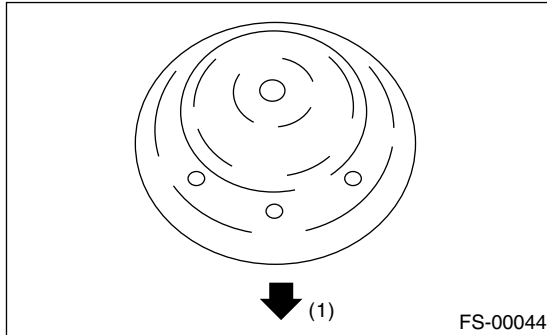

(1) Outside of body

8) Install the strut mount to the piston rod, and then tighten a new self-locking nut temporarily.

9) Using a hexagon wrench to prevent strut rod from turning, tighten the self-locking nut with ST.
ST 927760000 STRUT MOUNT SOCKET

Tightening torque:

55 N·m (5.6 kgf·m, 41 ft·lb)

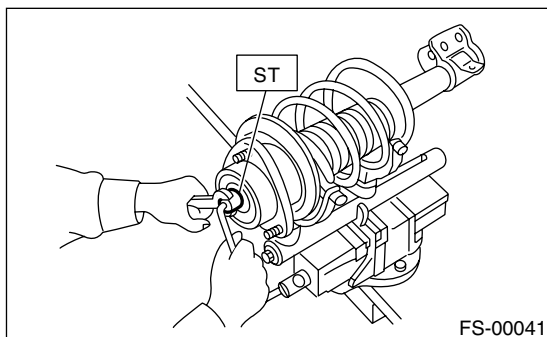

10) Loosen the coil spring carefully.

E: INSPECTION

Check the disassembled parts for cracks, damage and wear, and replace with new parts if defective.

1. DAMPER STRUT

1) Check for oil leakage.

2) Move the piston rod up and down to check that it operates smoothly without any binding.

3) Play of piston rod

- Measure the play as follows:

Fix outer shell and fully extend the rod. Set a dial gauge at the end of rod: L [10 mm (0.39 in)], then apply a force of W [20 N (2 kgf, 4 lb)] to threaded portion. With the force of 20 N (2 kgf, 4 lb) applied, read dial gauge indication: P₁. Apply a force of 20 N (2 kgf, 4 lb) in the opposite direction of "W", then read dial gauge indication: P₂.

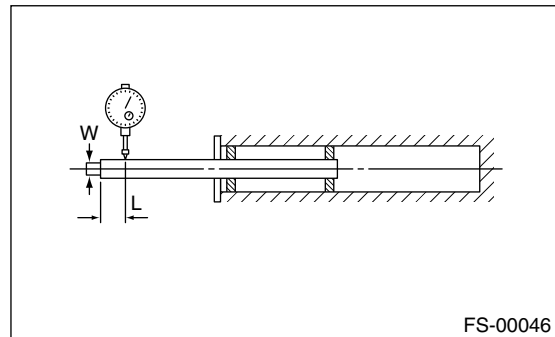

Limit of play (P₁ + P₂):
0.8 mm (0.031 in)

If the play is greater than limit, replace the strut.

2. STRUT MOUNT

Check the rubber part for creep, cracks and deterioration, and replace it with a new one if defective.

3. DUST COVER

If any cracks or damage are found, replace it with a new one.

4. COIL SPRING

One having permanent strain should be replaced with a new one. When the vehicle posture is uneven, although there are no considerable reasons like tire puncture, uneven loading, etc., check the coil spring for its free length referring to specifications, cracks, etc., and replace it with a new one if defective.

5. HELPER

Replace it with a new one if cracked or damaged.

FRONT STRUT

FRONT SUSPENSION

F: DISPOSAL

1. EXCEPT STi MODEL

CAUTION:

- Before handling gas filled struts, be sure to wear goggles to protect eyes from gas, oil and filings.
- Do not disassemble the strut damper or place into a fire.
- Drill holes before disposing of gas filled struts.

1) Place the gas filled strut on a flat and level surface with piston rod fully extended.

2) Using a 2 to 3 mm (0.08 to 0.12 in) dia. drill, make holes in areas shown in the figure.

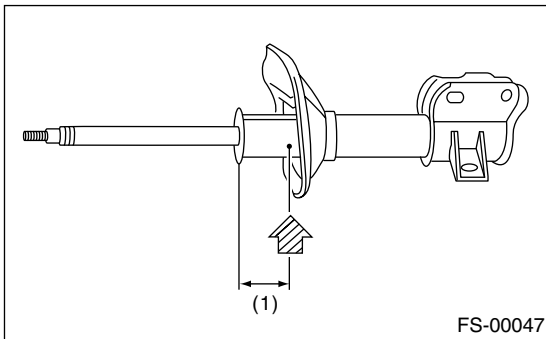

(1) 40 mm (1.57 in)

2. STi MODEL

CAUTION:

- Before handling gas filled struts, be sure to wear goggles to protect eyes from gas, oil and filings.
- Do not disassemble the strut damper or place into a fire.
- Drill holes before disposing of gas filled struts.

1) Place the gas filled strut on a flat and level surface with damping tube fully extended.

2) Using a 2 to 3 mm (0.08 to 0.12 in) dia. drill, make holes in (1), and then make a hole in (2).

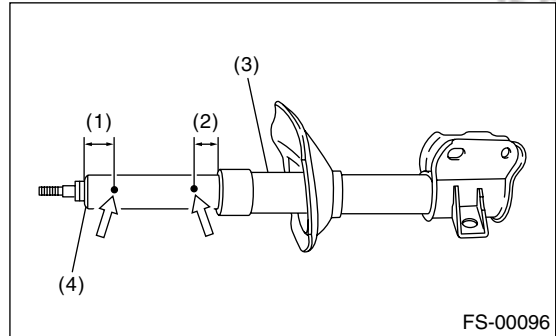

- (1) 20 mm (0.78 in)
- (2) 10 mm (0.39 in)
- (3) Strut
- (4) Damping tube

6. Front Stabilizer

A: REMOVAL

- 1) Jack-up the front part of the vehicle and support it with rigid racks.
- 2) Remove the jack-up plate from lower part of crossmember.
- 3) Remove the sub frame.
- 4) Remove the nut which secures stabilizer link to front transverse link.

SEDAN MODEL:

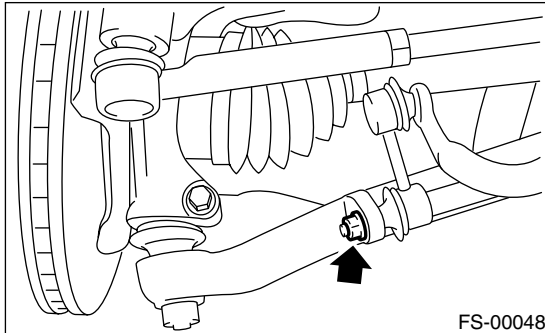

WAGON MODEL:

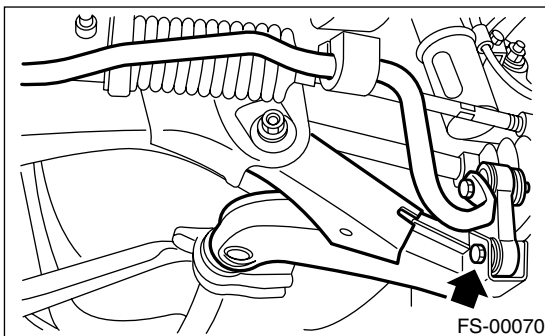

- 5) Remove the bolts which secure stabilizer to crossmember.

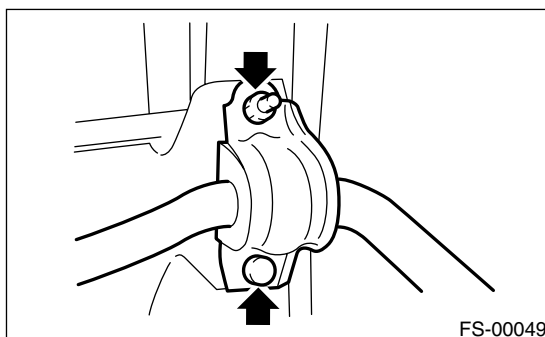

B: INSTALLATION

- 1) Install in the reverse order of removal.

NOTE:

- Install the bushing (on front crossmember side) while aligning it with paint mark on stabilizer.
- Ensure that bushing and stabilizer have the same identification colors when installing.

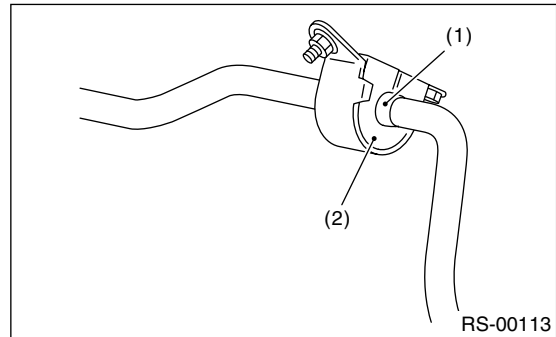

- (1) Mark stamped on stabilizer
- (2) Bushing identification color

- 2) Always tighten the bushing location when tires are in full contact with the ground and vehicle is curb weight.

Tightening torque:

Jack-up plate to crossmember (Except STi model):

20 N·m (2.0 kgf-m, 14.5 ft-lb)

Jack-up plate to crossmember (STi model):

70 N·m (7.1 kgf-m, 52 ft-lb)

Stabilizer link to front transverse link (STi model):

45 N·m (4.6 kgf-m, 33 ft-lb)

Stabilizer link to front transverse link (Except STi model):

30 N·m (3.1 kgf-m, 22 ft-lb)

Stabilizer to crossmember:

25 N·m (2.5 kgf-m, 18.1 ft-lb)

C: INSPECTION

- 1) Check the bushing for cracks, fatigue or damage.
- 2) Check the stabilizer link for deformities, cracks, or damage, and bushing for protrusions from the hole of stabilizer link.

7. Front Crossmember

A: REMOVAL

- 1) Disconnect the ground cable from battery.
- 2) Lift-up the vehicle, and then remove the front wheels.
- 3) Remove the sub frame.
- 4) Remove both the stabilizer and jack-up plate.

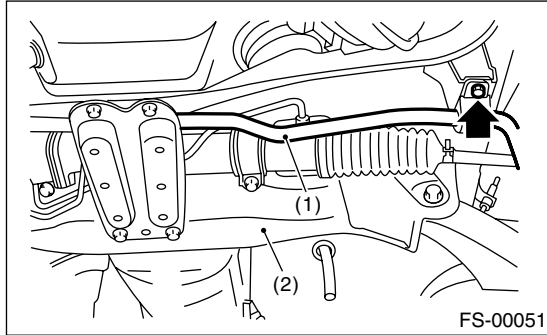

- (1) Front stabilizer
- (2) Front crossmember

- 5) Disconnect the tie-rod end from housing.
- 6) Remove the front exhaust pipe.
- 7) Remove the front transverse link from front crossmember and body.

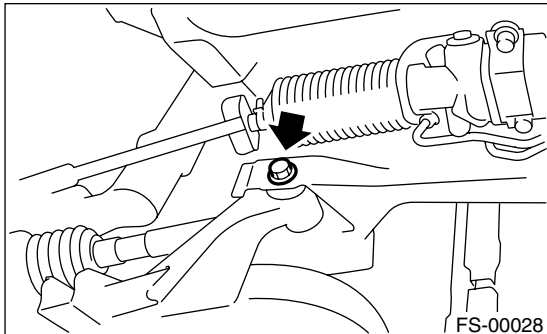

- 8) Remove the nuts attaching engine mount cushion rubber to crossmember.
- 9) Remove the steering universal joint.
- 10) Disconnect the power steering pipe from steering gear box.
- 11) Lift the engine by approx. 10 mm (0.39 in) by using chain block.
- 12) Support the crossmember with a jack, remove nuts securing crossmember to body and lower the crossmember gradually along with steering gear-box.

CAUTION:

When removing the crossmember downward, be careful that tie-rod end does not interfere with SFJ boot.

B: INSTALLATION

- 1) Install in the reverse order of removal.

NOTE:

Always tighten the bushing when tires are in full contact with the ground and vehicle is curb weight.

Tightening torque:

Transverse link bushing to crossmember:

125 N·m (12.7 kgf-m, 92 ft-lb)

Stabilizer to bushing:

25 N·m (2.5 kgf-m, 18.1 ft-lb)

Tie-rod end to housing:

27.0 N·m (2.75 kgf-m, 19.9 ft-lb)

Front cushion rubber to crossmember:

85 N·m (8.7 kgf-m, 62.7 ft-lb)

Universal joint to pinion shaft:

24 N·m (2.4 kgf-m, 17.4 ft-lb)

Crossmember to body:

105 N·m (10.7 kgf-m, 77 ft-lb)

- 2) Purge air from the power steering system.
- 3) Check the wheel alignment and adjust if necessary.

C: INSPECTION

Check the crossmember for wear, damage and cracks, and correct or replace if defective.

8. Sub Frame

A: REMOVAL

- 1) Lift-up the vehicle.
- 2) Remove the under cover.
- 3) Remove the bolt cover.

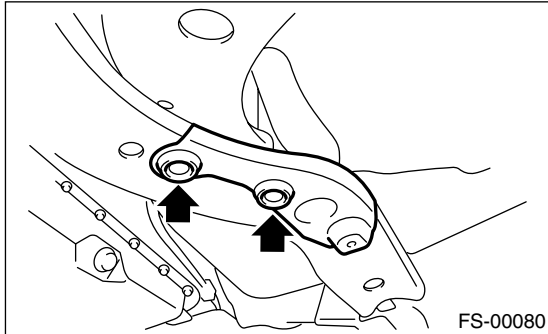

- 4) Remove the clip.

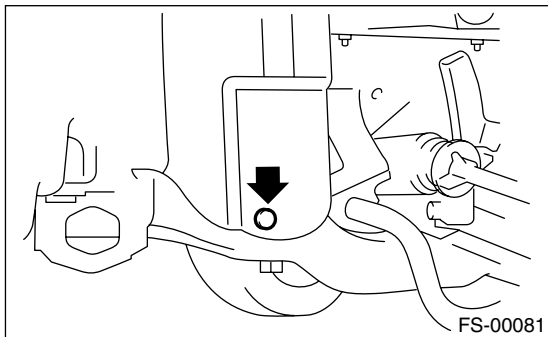

- 5) Remove the sub frame.

NOTE:

Loosen bolt (1) and leave a few threads caught, then remove the bolts in the order of (2), (3), (4), (5), and (6).

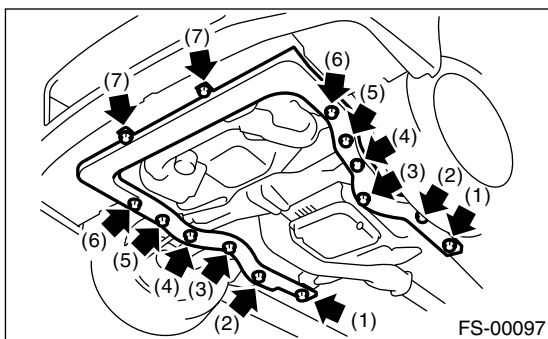

- (4) Only for STi model

B: INSTALLATION

Install in the reverse order of removal.

NOTE:

Replace the M12 bolt with a new one.

Tightening torque:

T1: 34 N·m (3.5 kgf-m, 25 ft-lb)

T2: 55 N·m (5.6 kgf-m, 41 ft-lb)

T3: 71 N·m (7.2 kgf-m, 52 ft-lb)

T4: 105 N·m (10.7 kgf-m, 77 ft-lb)

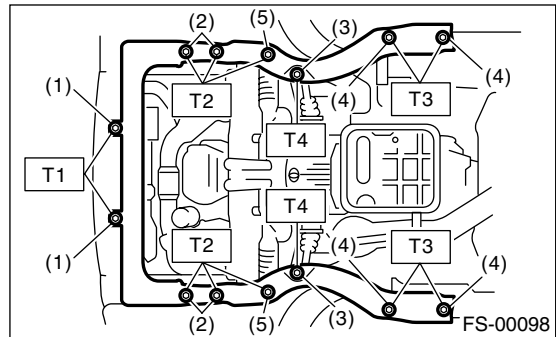

- (1) M8 bolt
- (2) M12 bolt (with wax)
- (3) M12 bolt (with oil)
- (4) M10 bolt
- (5) M12 bolt (Only for STi model)

C: INSPECTION

- 1) Check that there is no damage and distortion at the sub frame.
- 2) Check that the bolts are tightened with the specified torque. If there is looseness, tighten to the specified torque.

NOTE:

The tightening torque differs by the color for bolt (3). Always verify the bolt color before checking tightening torque.

Tightening torque:

T1: 34 N·m (3.5 kgf-m, 25 ft-lb)

T2: 55 N·m (5.6 kgf-m, 41 ft-lb)

T3: 71 N·m (7.2 kgf-m, 52 ft-lb)

T4: Dark green bolt

105 N·m (10.7 kgf-m, 77 ft-lb)

T4: Except dark green bolt

55 N·m (5.6 kgf-m, 41 ft-lb)

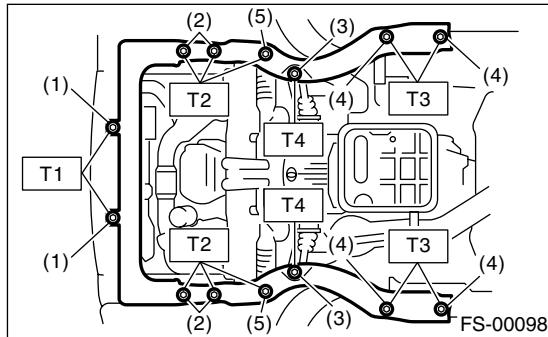

- (1) M8 bolt
- (2) M12 bolt
- (3) M12 bolt
- (4) M10 bolt
- (5) M12 bolt (Only for STi model)

9. Front Support Arm

A: REMOVAL

- 1) Set the vehicle on a lift.
- 2) Lift-up the vehicle.
- 3) Remove the under cover.
- 4) Remove the four bolts and jack-up plate.

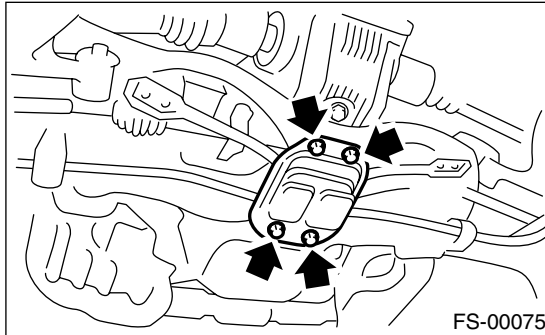

- 5) Remove the two nuts at both ends of arm respectively.

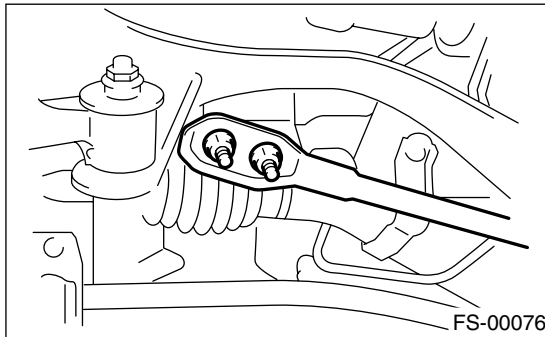

B: INSTALLATION

Install in the reverse order of removal.

Tightening torque:

Front support arm to crossmember:

30 N·m (3.1 kgf-m, 22 ft-lb)

Jack-up plate to crossmember:

70 N·m (7.1 kgf-m, 52 ft-lb)

C: INSPECTION

Check the front support arm for wear, damage and cracks, and correct or replace if defective.

GENERAL DIAGNOSTIC TABLE

FRONT SUSPENSION

10. General Diagnostic Table

A: INSPECTION

1. IMPROPER VEHICLE POSTURE OR IMPROPER WHEEL ARCH HEIGHT

Possible causes	Countermeasures
(1) Permanent distortion or breakage of coil spring	Replace.
(2) Unsmooth operation of damper strut and/or shock absorber	Replace.
(3) Installation of wrong strut and/or shock absorber	Replace with proper parts.
(4) Installation of wrong coil spring	Replace with proper parts.

2. POOR RIDE COMFORT

- 1) Large rebound shock
- 2) Rocking of the vehicle continues too long after running over bump and/or hump.
- 3) Large shock in bumping

Possible causes	Countermeasures
(1) Breakage of coil spring	Replace.
(2) Overinflating pressure of tire	Adjust.
(3) Improper wheel arch height	Adjust or replace the coil springs with new ones.
(4) Fault in operation of damper strut and/or shock absorber	Replace.
(5) Damage or deformation of strut mount and/or shock absorber mount	Replace.
(6) Unsuitability of maximum and/or minimum length of damper strut and/or shock absorber	Replace with proper parts.
(7) Deformation or loss of bushing	Replace.
(8) Deformation or damage of helper in strut assembly and/or shock absorber	Replace.
(9) Oil leakage of damper strut and/or shock absorber	Replace.

3. NOISE

Possible causes	Countermeasures
(1) Wear or damage of damper strut and/or shock absorber component parts	Replace.
(2) Loosening of suspension link installing bolt	Retighten to the specified torque.
(3) Deformation or loss of bushing	Replace.
(4) Unsuitability of maximum and/or minimum length of damper strut and/or shock absorber	Replace with proper parts.
(5) Breakage of coil spring	Replace.
(6) Wear or damage of ball joint	Replace.
(7) Deformation of stabilizer clamp	Replace.