

Brought to you by Eris Studios
NOT FOR RESALE

REAR SUSPENSION

1. General Description

A: SPECIFICATIONS

Model	Sedan			Wagon		OUTBACK
	Non-turbo	Turbo	STi	Non-turbo	Turbo	
Camber (tolerance: $\pm 0^{\circ}45'$)	$-1^{\circ}25'$	$-1^{\circ}30'$	$-1^{\circ}40'$	$-1^{\circ}15'$	$-1^{\circ}20'$	$-1^{\circ}10'$
Toe-in	0 \pm 3 mm (0 \pm 0.12 in) Each toe angle: $\pm 0^{\circ}09'$					
Thrust angle	0 \pm 30'					
Wheel arch height [tolerance: ± 12 mm (± 0.47 in)]	381 mm (15.0 in)	376 mm (14.80 in)	366 mm (14.41 in)	381 mm (15.0 in)	376 mm (14.80 in)	386 mm (15.20 in)
Diameter of stabilizer	13 mm (0.51 in)	17 mm (0.67 in)	20 mm (0.79 in)	13 mm (0.51 in)	17 mm (0.67 in)	13 mm (0.51 in)

NOTE:

- Front and rear toe-ins and front camber can be adjusted. If toe-in or camber tolerance exceeds specifications, adjust toe-in and camber to the middle value of specification.
- The other items indicated in the specification table cannot be adjusted. If the other items exceeds specifications, check suspension parts and connections for deformities; replace with new ones as required.

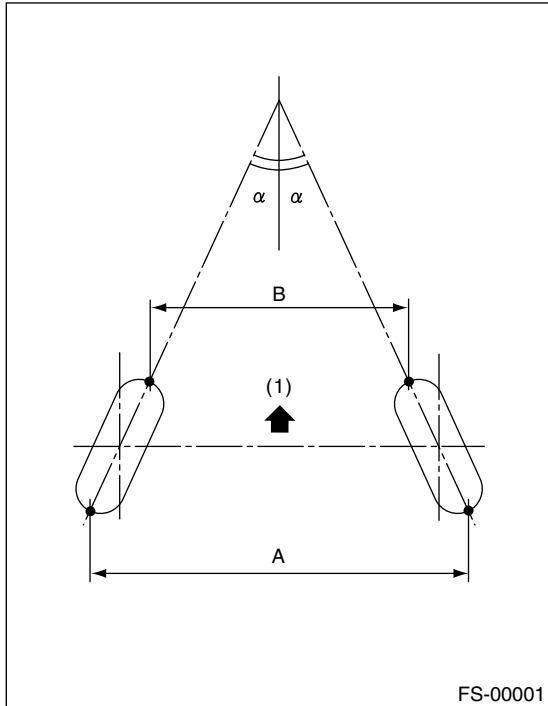

(1) Front

A – B = Positive: Toe-in, Negative: Toe-out

α = Each toe angle

B: COMPONENT

1. REAR SUSPENSION

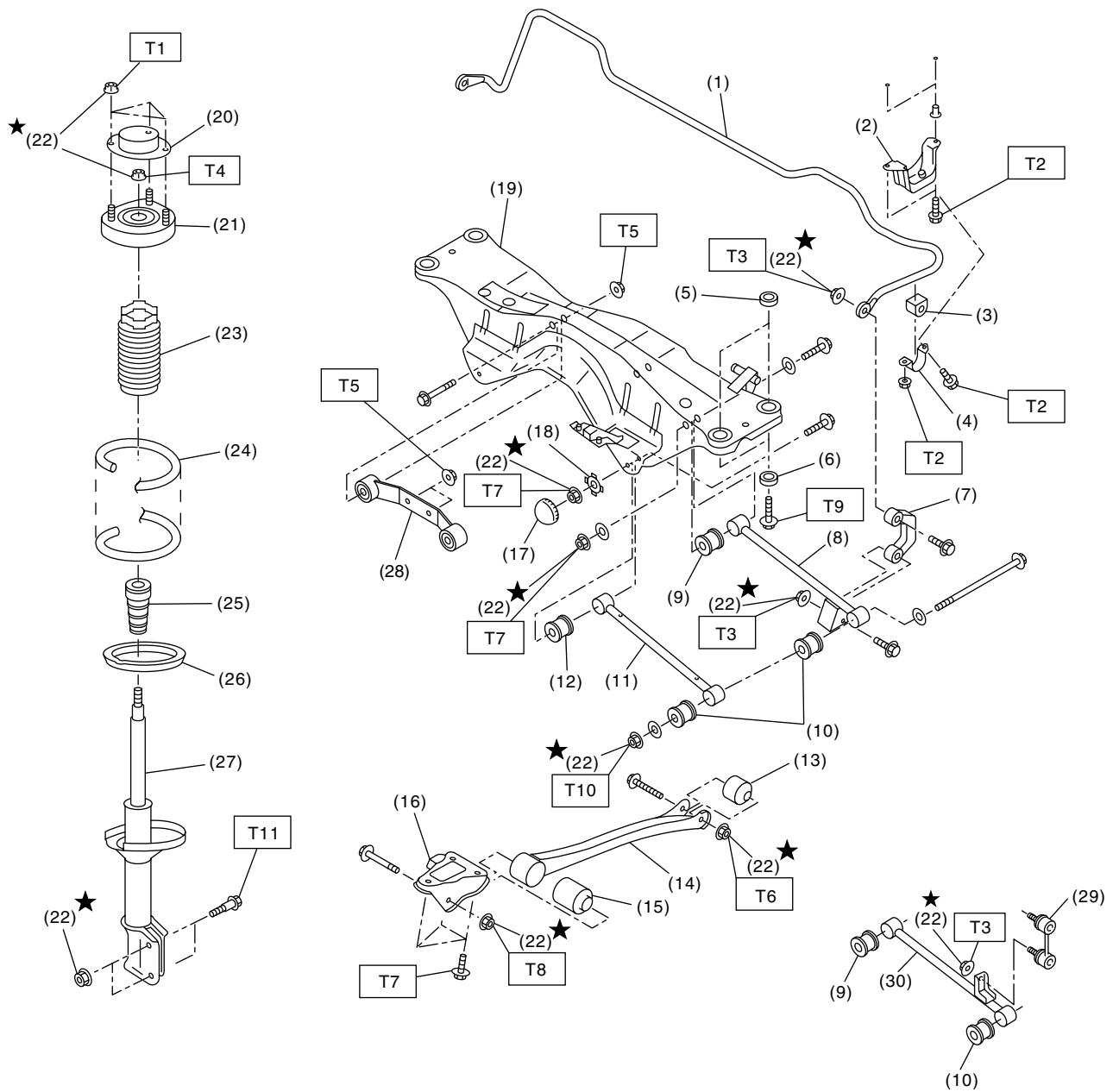

RS-00111

GENERAL DESCRIPTION

REAR SUSPENSION

(1) Stabilizer	(15) Trailing link front bushing	(30) Rear lateral link (STi model)
(2) Stabilizer bracket	(16) Trailing link bracket	
(3) Stabilizer bushing	(17) Cap (Protection)	
(4) Clamp	(18) Washer	Tightening torque: N-m (kgf-m, ft-lb)
(5) Floating bushing	(19) Rear crossmember	T1: 20 (2.0, 14.5)
(6) Stopper	(20) Strut mount cap	T2: 25 (2.5, 18.1)
(7) Stabilizer link (except STi model)	(21) Strut mount	T3: 45 (4.6, 33.2)
(8) Rear lateral link (with stabilizer, except STi model)	(22) Self-locking nut	T4: 60 (6.1, 44)
(9) Bushing (C)	(23) Dust cover	T5: 70 (7.1, 52)
(10) Bushing (A)	(24) Coil spring	T6: 90 (9.2, 66)
(11) Front lateral link	(25) Helper	T7: 100 (10.2, 74)
(12) Bushing (B)	(26) Lower rubber seat	T8: 115 (11.7, 85)
(13) Trailing link rear bushing	(27) Damper strut	T9: 130 (13.3, 96)
(14) Trailing link	(28) Rear differential member rear	T10: 140 (14.3, 103)
	(29) Stabilizer link (STi model)	T11: 200 (20.0, 145)

C: CAUTION

- Wear working clothing, including a cap, protective goggles, and protective shoes during operation.
- Before disposing shock absorbers, be sure to bleed gas completely. Also, do not throw away in fire.
- Before removal, installation or disassembly, be sure to clarify the failure. Avoid unnecessary removal, installation, disassembly, and replacement.

- Use SUBARU genuine grease etc. or the equivalent. Do not mix grease etc. with that of another grade or from other manufacturers.
- Be sure to tighten fasteners including bolts and nuts to the specified torque.
- Place shop jacks or safety stands at the specified points.
- Before securing a part on a vise, place cushioning material such as wood blocks, aluminum plate, or shop cloth between the part and the vise.

D: PREPARATION TOOL

1. SPECIAL TOOLS

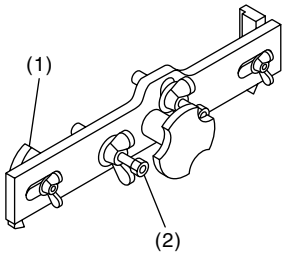
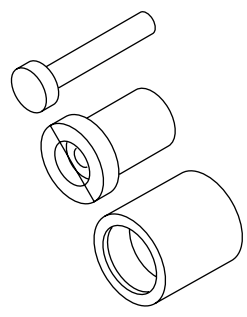
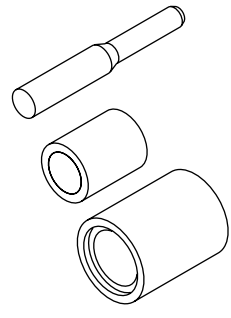
ILLUSTRATION	TOOL NUMBER	DESCRIPTION	REMARKS
 <p style="text-align: center;">ST-927380002</p>	927380002	ADAPTER	Used as an adapter for camber & caster gauge when measuring camber and caster. (1) 28199AC000 PLATE (2) 28199AC010 BOLT
 <p style="text-align: center;">ST-927720000</p>	927720000	INSTALLER & REMOVER	Used for replacing front bushing.
 <p style="text-align: center;">ST-927730000</p>	927730000	INSTALLER & REMOVER	Used for replacing rear bushing.

GENERAL DESCRIPTION

REAR SUSPENSION

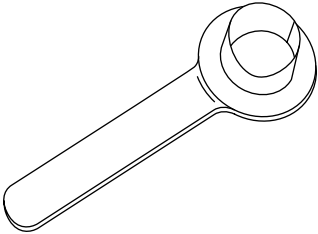
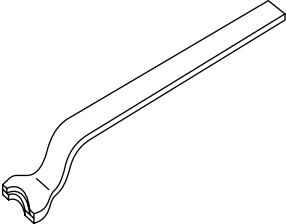
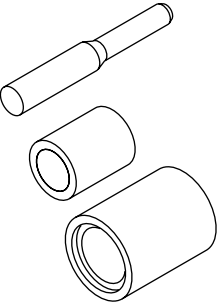
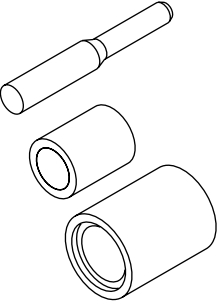
ILLUSTRATION	TOOL NUMBER	DESCRIPTION	REMARKS
 <p style="text-align: center;">ST28099PA090</p>	<p style="text-align: center;">28099PA090</p>	<p>OIL SEAL PROTECTOR</p>	<ul style="list-style-type: none"> • Used for installing rear drive shaft to rear differential. • For protecting oil seal.
 <p style="text-align: center;">ST28099PA100</p>	<p style="text-align: center;">28099PA100</p>	<p>REMOVER</p>	<p>Used for removing DOJ.</p>
 <p style="text-align: center;">ST-927710000</p>	<p style="text-align: center;">927710000</p>	<p>INSTALLER & REMOVER</p>	<p>Used for replacing lateral link bushing.</p>
 <p style="text-align: center;">ST-927700000</p>	<p style="text-align: center;">927700000</p>	<p>INSTALLER & REMOVER</p>	<p>Used for replacing lateral link bushing.</p>

GENERAL DESCRIPTION

REAR SUSPENSION

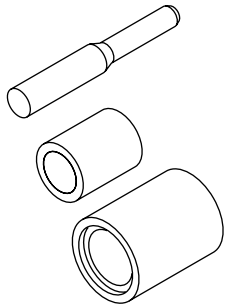
ILLUSTRATION	TOOL NUMBER	DESCRIPTION	REMARKS
 ST-927690000	927690000	INSTALLER & REMOVER	Used for replacing lateral link bushing.

2. GENERAL PURPOSE TOOLS

TOOL NAME	REMARKS
Alignment gauge	Used for wheel alignment measurement.
Turning radius gauge	Used for wheel alignment measurement.
Toe-in gauge	Used for toe-in measurement.
Transmission jack	Used for suspension assembly/disassembly.
Bearing puller	Used for removing bushings.
Coil spring compressor	Used for strut assembly/disassembly.

2. Wheel Alignment

A: INSPECTION

NOTE:

Front and rear wheel alignment must be simultaneously measured and/or adjusted. Follow the procedure in "FS" section "Wheel Alignment" for measurement and/or adjustment of wheel alignment. <Ref. to FS-6, INSPECTION, Wheel Alignment.>

Brought to you by Eris Studios
NOT FOR RESALE

3. Rear Stabilizer

A: REMOVAL

- 1) Lift-up the vehicle.
- 2) Remove the stabilizer link.
 - Except STi MODEL

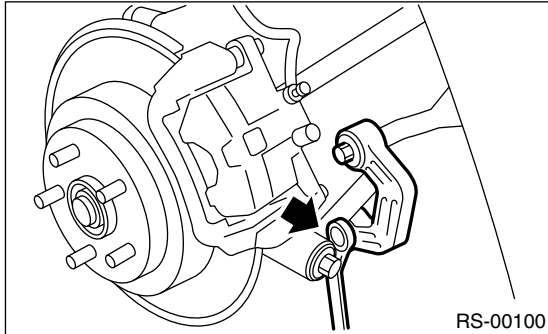

- STi MODEL

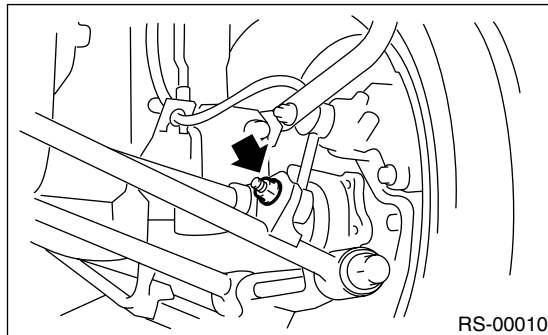

- 3) Remove the bolt and nut which secure the stabilizer to stabilizer bracket.

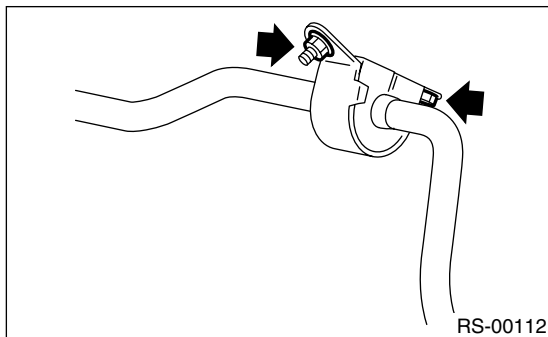

B: INSTALLATION

- 1) Install in the reverse order of removal.

NOTE:

- Install the stabilizer bushing while aligning it with paint mark on stabilizer.
- Ensure the stabilizer bushing and stabilizer have the same identification colors when installing.

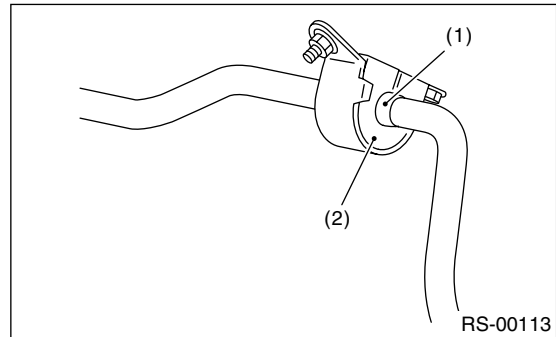

- (1) Mark painted on stabilizer
- (2) Bushing identification color

- 2) Always tighten the stabilizer bushing location when tires are in full contact with the ground and the vehicle is curb weight.

Tightening torque:

Stabilizer link to rear lateral link

45 N·m (4.6 kgf-m, 33.2 ft-lb)

Stabilizer to stabilizer bracket

25 N·m (2.5 kgf-m, 18.1 ft-lb)

C: INSPECTION

- 1) Check the bushing for cracks, fatigue or damage.
- 2) Check the stabilizer links for deformities, cracks, or damage, and bushing for protrusions from the hole of stabilizer link.

4. Rear Trailing Link

A: REMOVAL

- 1) Loosen the rear wheel nuts.
- 2) Lift-up the vehicle, and then remove the rear wheels.
- 3) Remove both the rear parking brake clamp and ABS wheel speed sensor harness.
- 4) Remove the bolt which secures the trailing link to trailing link bracket.

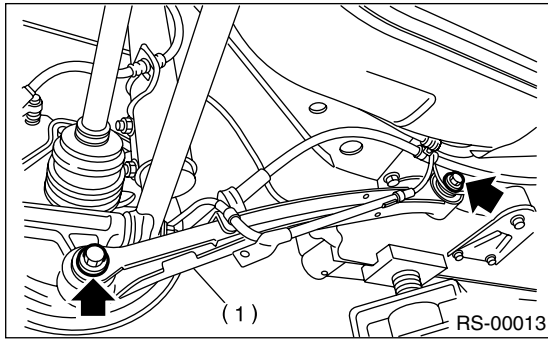

(1) Trailing link

- 5) Remove the bolt which secures the trailing link to rear housing.

B: INSTALLATION

- 1) Install in the reverse order of removal.
- 2) Always tighten the bushing location when tires are in full contact with the ground and the vehicle is at curb weight condition.

NOTE:

Check the wheel alignment and adjust if necessary.

C: DISASSEMBLY

1. FRONT BUSHING

Using the ST, press the front bushing out of place.
 ST 927720000 INSTALLER & REMOVER SET

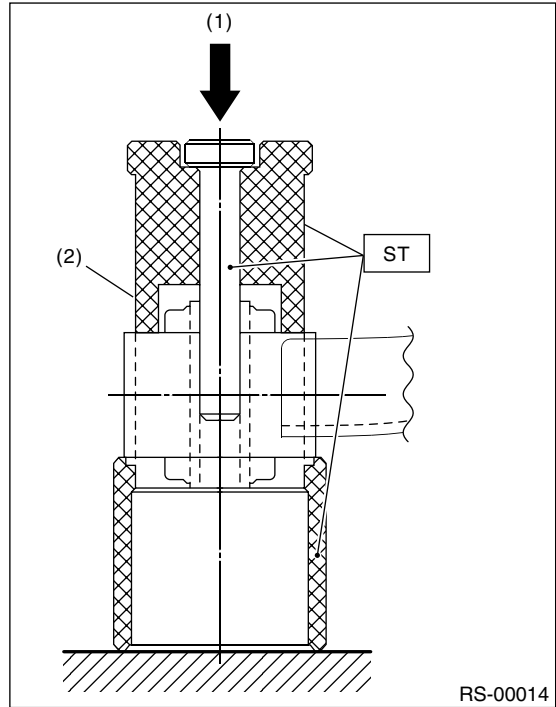

- (1) Press
- (2) Trailing link

2. REAR BUSHING

- 1) Remove the housing. <Ref. to DS-23, REMOV-AL, Rear Axle.>
- 2) Using the ST, press the rear bushing out of place.

ST 927730000 INSTALLER & REMOVER SET

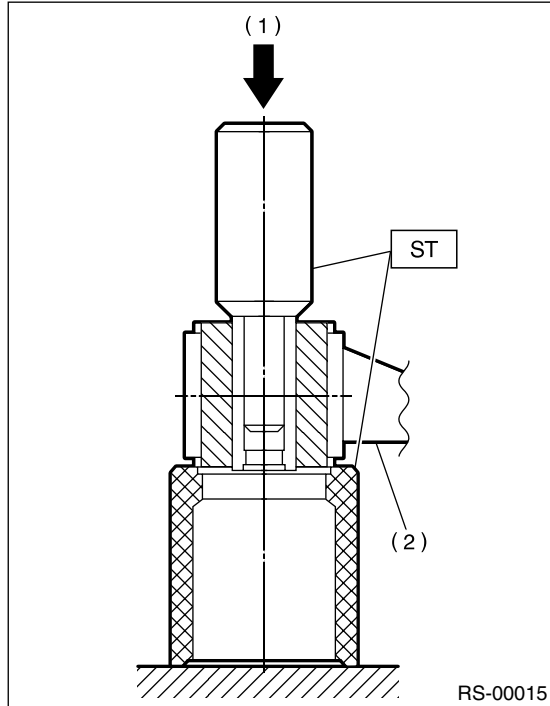

- (1) Press
- (2) Housing

D: ASSEMBLY

1. FRONT BUSHING

Using the ST, press the bushing into trailing link.
ST 927720000 INSTALLER & REMOVER SET

CAUTION:

Turn the ST plunger upside down and press it until the plunger end surface contacts the trailing link end surface.

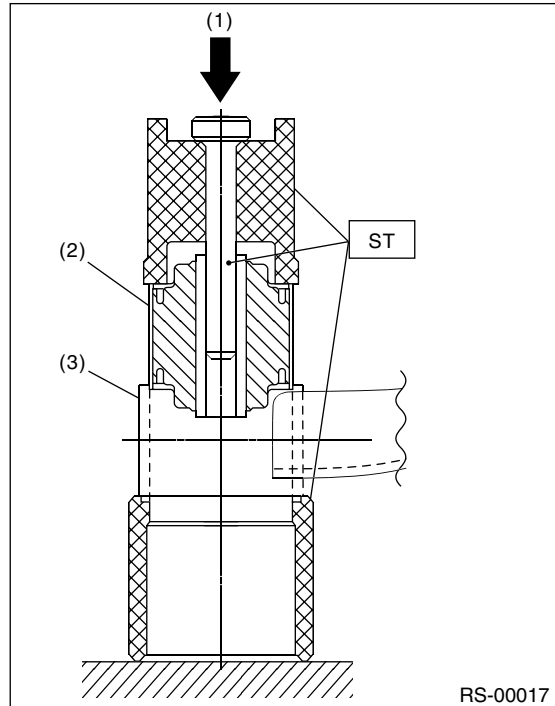

- (1) Press
- (2) Front bushing
- (3) Trailing link

CAUTION:

Install the front bushing in the proper direction, as shown in the figure.

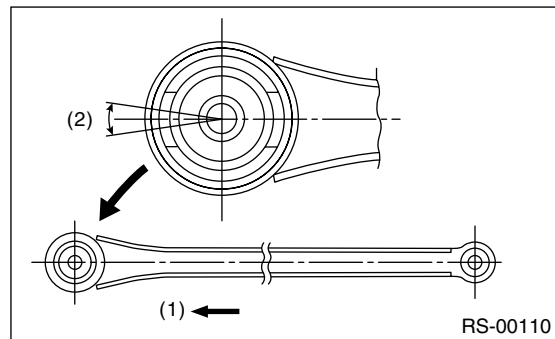

- (1) Front
- (2) $\pm 5^\circ$

REAR TRAILING LINK

REAR SUSPENSION

2. REAR BUSHING

1) Using the ST, press the bushing into trailing link.
ST 927730000 INSTALLER & REMOVER SET

NOTE:

If it is difficult to press the bushing into trailing link, apply water-diluted TIRE LUBE to the inner surface of ST as a lubricant.

SPECIFIED lubricant:

TIRE LUBE: water = 1: 3

2) Press the ST plunger until the bushing flange protrudes beyond trailing link.
ST 927730000 INSTALLER & REMOVER SET

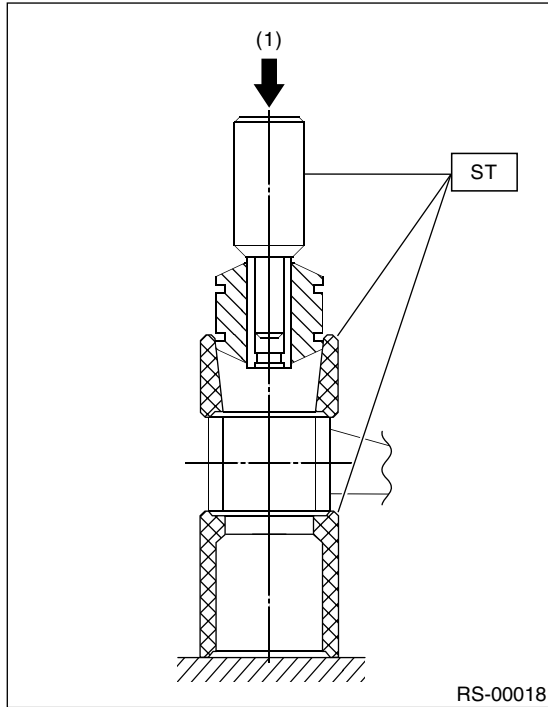

(1) Press

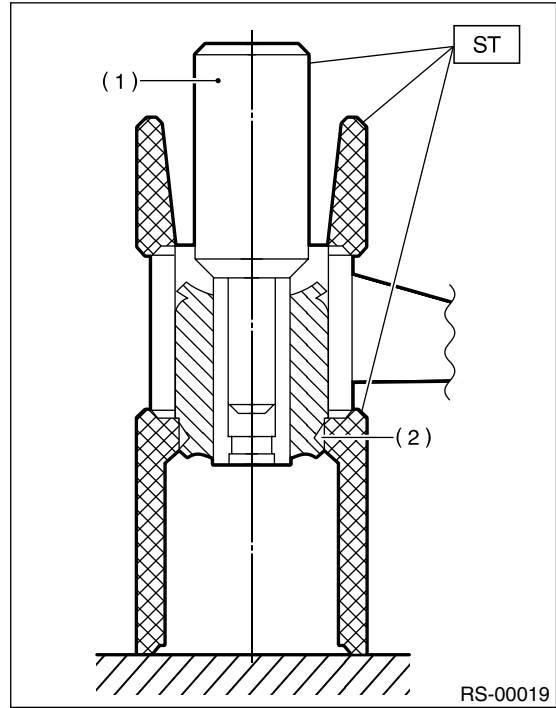

- (1) Plunger
- (2) Flange

3) Turn the trailing link upside down. Press the ST plunger in the opposite direction that outlines in the former procedure until bushing is correctly positioned in trailing link.

ST 927730000 INSTALLER & REMOVER SET

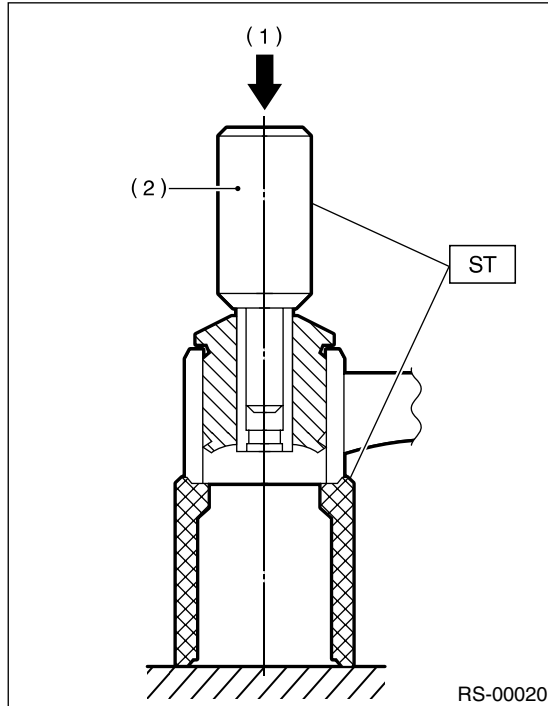

- (1) Press
- (2) Plunger

4) Install the housing. <Ref. to DS-24, INSTALLATION, Rear Axle.>

E: INSPECTION

Check the trailing links for bends, corrosion or damage.

5. Rear Strut

A: REMOVAL

- 1) Remove the rear seat cushion and backrest. (Sedan model)
- 2) Remove the strut cap of quarter trim. (Wagon model)
- 3) Loosen the rear wheel nuts.
- 4) Lift-up the vehicle, and remove rear wheels.
- 5) Remove the brake hose clip, and then remove the brake hose from rear strut.

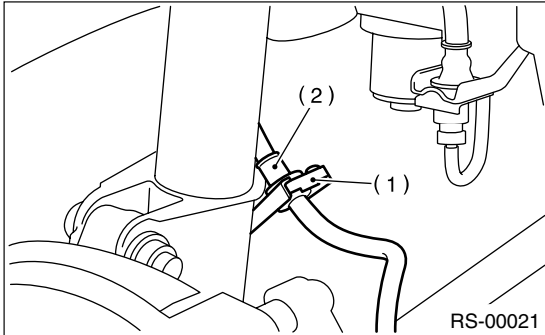

- (1) Brake hose clip
- (2) Brake hose

- 6) Remove the bolts which secure the rear strut to housing.

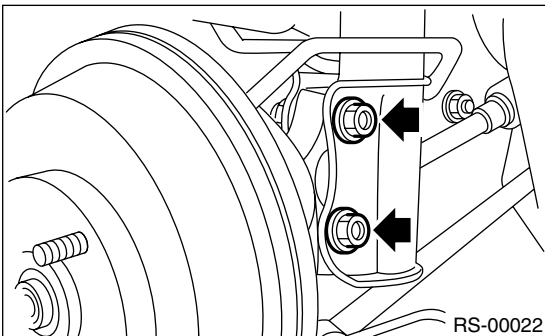

- 7) Remove the nuts securing strut mount to body.

B: INSTALLATION

- 1) Secure the strut mount to vehicle body using a new self-locking nut.

Tightening torque:

20 N·m (2.0 kgf-m, 14.5 ft-lb)

- 2) Secure the rear strut to housing using a new self-locking nut.

Tightening torque:

200 N·m (20.0 kgf-m, 145 ft-lb)

- 3) Install the brake hose to lower side of strut, then insert the brake hose clip.

CAUTION:

- Check the hose clip is positioned properly.
- Check the brake hose for twisting, or excessive tension.
- Do not subject the ABS wheel speed sensor harness to excessive tension.

- 4) Lower the vehicle and tighten wheel nut.

Tightening torque:

90 N·m (9.2 kgf-m, 66 ft-lb)

- 5) Install the rear seat backrest and rear seat cushion. (Sedan model)

- 6) Install the strut cap to rear quarter trim. (Wagon model)

NOTE:

Check the wheel alignment and adjust if necessary.

C: DISASSEMBLY

For disassembly of rear strut, refer to procedures outlined under front strut as a guide. <Ref. to FS-20, DISASSEMBLY, Front Strut.>

D: ASSEMBLY

Refer to Front Strut as a guide for assembly procedures. <Ref. to FS-20, ASSEMBLY, Front Strut.>

E: INSPECTION

Refer to Front Strut as a guide for inspection procedures. <Ref. to FS-21, INSPECTION, Front Strut.>

F: DISPOSAL

Refer to Front Strut as a guide for disposal procedures. <Ref. to FS-22, DISPOSAL, Front Strut.>

6. Lateral link

A: REMOVAL

- 1) Loosen the wheel nuts. Lift-up the vehicle and remove wheel.
- 2) Remove the stabilizers.
- 3) Remove the ABS wheel speed sensor harness from trailing link.
- 4) Remove the bolt securing trailing link to rear housing.

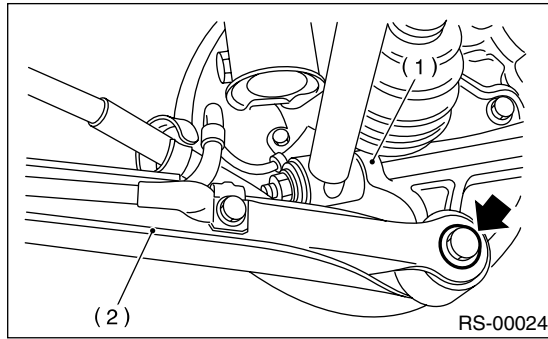

- (1) Rear housing
- (2) Trailing link

- 5) Remove the bolts which secure the lateral link assembly to rear housing.
- 6) Remove the DOJ from rear differential using ST. ST 28099PA100 DRIVE SHAFT REMOVER

NOTE:

The side spline shaft circlip comes out together with the shaft.

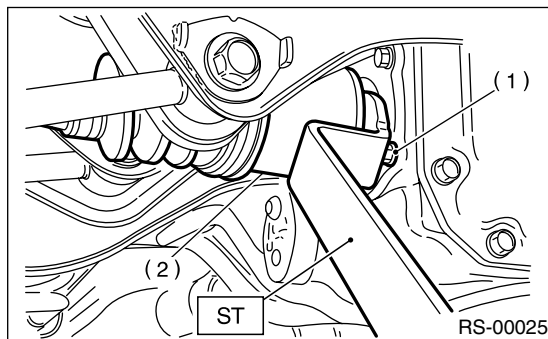

- (1) Bolt
- (2) DOJ

CAUTION:

Be careful not to damage the side bearing retainer. Always use bolt shown in the figure, as supporting point for ST during removal.

- 7) Scribe an alignment mark on the rear lateral link adjusting bolt and crossmember.

- 8) Remove the bolts securing front and rear lateral links to crossmember, detach lateral links.

CAUTION:

To loosen the adjusting bolt, always loosen the nut while holding head of adjusting bolt.

B: INSTALLATION

Install in the reverse order of removal. Observe the following instructions.

- Installation of DOJ to differential: <Ref. to DS-35, INSTALLATION, Rear Drive Shaft.>

CAUTION:

- Replace the self-locking nut and DOJ circlip with new ones.
- Always use the special tool not to allow the DOJ splines to damage the side oil seal. ST 28099PA090 OIL SEAL PROTECTOR
- Always tighten the bushing location when tires are in full contact with the ground and vehicle is curb weight.
- Secure the bolt head and tighten the nut when installing the adjusting bolt.

NOTE:

Check the wheel alignment and adjust if necessary.

C: DISASSEMBLY

- 1) Using the following table as a guide, verify the type of bushings.
- 2) Select the ST according to type of bushings used.

Bushing	ST: INSTALLER & REMOVER SET
Bushing A	927700000
Bushing B	927690000
Bushing C	927700000

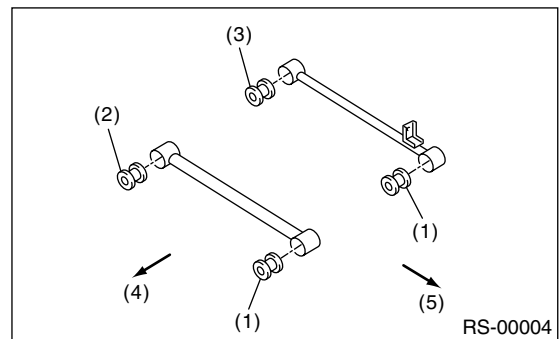

- (1) Bushing A
- (2) Bushing B
- (3) Bushing C
- (4) Front
- (5) Outside of body

LATERAL LINK

REAR SUSPENSION

3) Using the ST, press the bushing out of place.

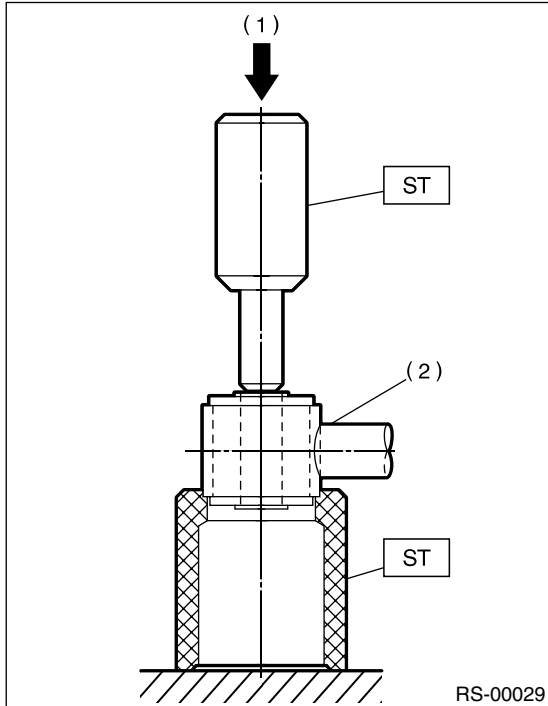

- (1) Press
- (2) Lateral link

3) Using the ST, press the bushing into place.

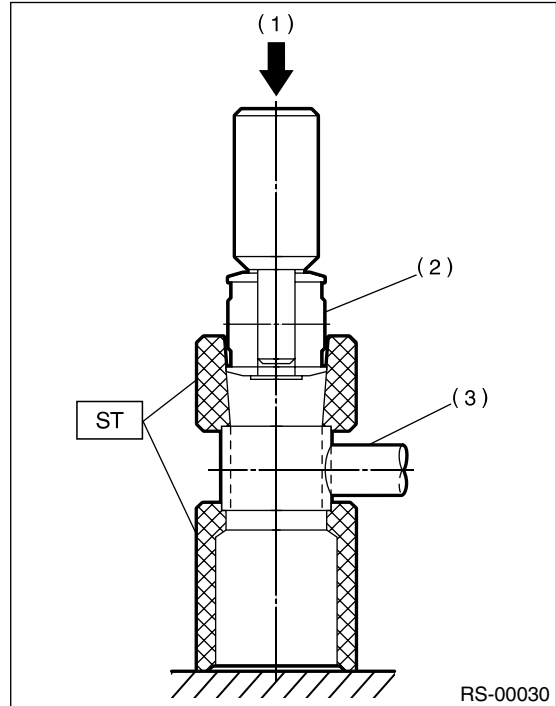

- (1) Press
- (2) Bushing
- (3) Lateral link

D: ASSEMBLY

- 1) Use the same ST that was used during disassembly.
- 2) If it is difficult to press the bushing into trailing link, apply water-diluted TIRE LUBE to the inner surface of ST as a lubricant.

Specified lubricant:

TIRE LUBE: water = 1: 3

LATERAL LINK

REAR SUSPENSION

4) Press the ST plunger until bushing flange protrudes beyond lateral link.

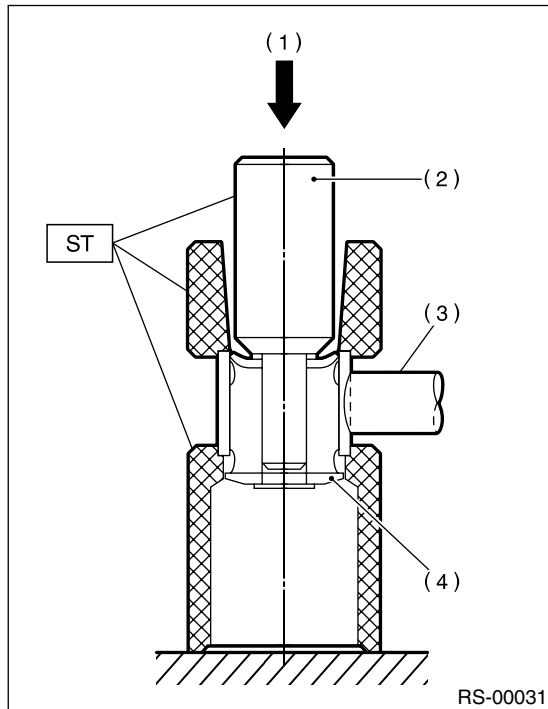

- (1) Press
- (2) Plunger
- (3) Lateral link
- (4) Flange

5) Turn the lateral link upside down. Press the ST plunger in opposite direction that outlined in the former procedure until bushing is correctly positioned in trailing link.

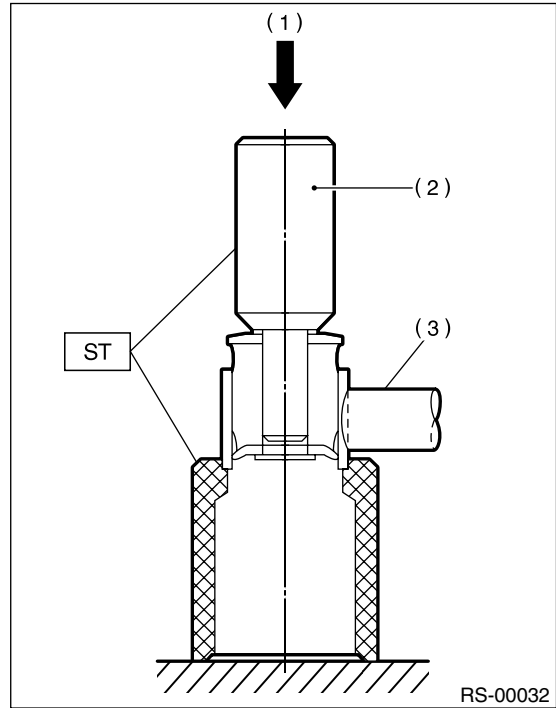

- (1) Press
- (2) Plunger
- (3) Lateral link

E: INSPECTION

Visually check the lateral links for damage or bends.

7. Rear Crossmember

A: REMOVAL

CAUTION:

Do not subject the ABS wheel speed sensor harness to excessive tension.

- 1) Separate the front exhaust pipe and rear exhaust pipe.
- 2) Remove the rear exhaust pipe and muffler.
- 3) Remove the rear differential.
<Ref. to DI-22, REMOVAL, Rear Differential.>
- 4) Place the transmission jack under rear crossmember.

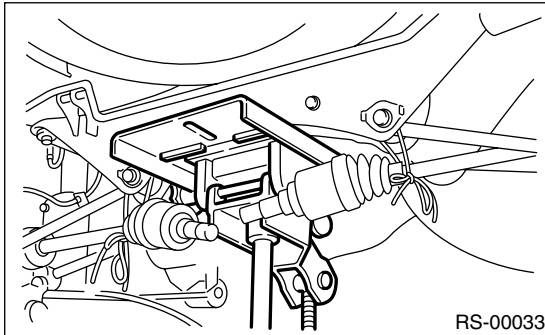

- 5) Remove the bolts securing crossmember to vehicle body, and then remove the crossmember.

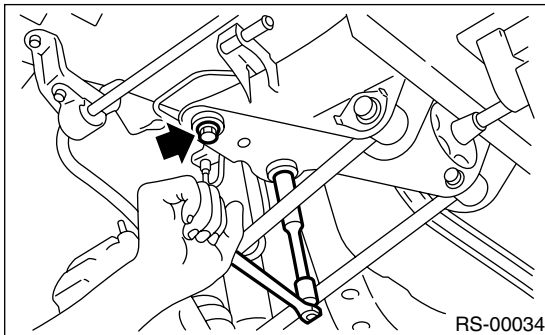

- 6) Scribe an alignment mark on the rear lateral link cam bolt and crossmember.
- 7) Remove the front and rear lateral links by loosening nuts.

B: INSTALLATION

NOTE:

- Discard the loosened self-locking nut and replace it with a new one.
- Always secure the bolt head and tighten the nut when tightening the adjusting bolt.

- 1) Install in the reverse order of removal.
- 2) For installation and tightening torque of rear differential;
<Ref. to DI-24, INSTALLATION, Rear Differential.>
- 3) Always tighten the rubber bushing when tires are in full contact with the ground and vehicle is curb weight.
- 4) Check the wheel alignment and adjust if necessary.

C: INSPECTION

Check the removed parts for wear, damage and cracks, and correct or replace if defective.

8. General Diagnostic Table

A: INSPECTION

1. IMPROPER VEHICLE POSTURE OR IMPROPER WHEEL ARCH HEIGHT

Possible causes	Countermeasures
(1) Permanent distortion or breakage of coil spring	Replace.
(2) Irregular operation of damper strut or shock absorber	Replace.
(3) Installation of wrong strut or shock absorber	Replace with proper parts.
(4) Installation of wrong coil spring	Replace with proper parts.

2. POOR RIDE COMFORT

- 1) Large rebound shock
- 2) Rocking of the vehicle continues too long after running over bump and/or hump
- 3) Large shock in bumping

Possible causes	Countermeasures
(1) Breakage of coil spring	Replace.
(2) Overinflating pressure of tire	Adjust.
(3) Improper wheel arch height	Adjust or replace the coil springs with new ones.
(4) Fault in operation of damper strut or shock absorber	Replace.
(5) Damage or deformation of strut mount or shock absorber mount	Replace.
(6) Unsuitability of maximum or minimum length of damper strut or shock absorber	Replace with proper parts.
(7) Deformation or loss of bushing	Replace.
(8) Deformation or damage of helper in strut assembly or shock absorber	Replace.
(9) Oil leakage of damper strut or shock absorber	Replace.

3. NOISE

Possible causes	Countermeasures
(1) Wear or damage of damper strut or shock absorber component parts	Replace.
(2) Loosening of suspension link installing bolt	Retighten to the specified torque.
(3) Deformation or loss of bushing	Replace.
(4) Unsuitability of maximum or minimum length of damper strut or shock absorber	Replace with proper parts.
(5) Breakage of coil spring	Replace.
(6) Wear or damage of ball joint	Replace.
(7) Deformation of stabilizer clamp	Replace.

GENERAL DIAGNOSTIC TABLE

Brought to you by Eris Studios
NOT FOR RESALE