

Brought to you by Eris Studios  
NOT FOR RESALE

# WHEEL AND TIRE SYSTEM

# GENERAL DESCRIPTION

## WHEEL AND TIRE SYSTEM

### 1. General Description

#### A: SPECIFICATIONS

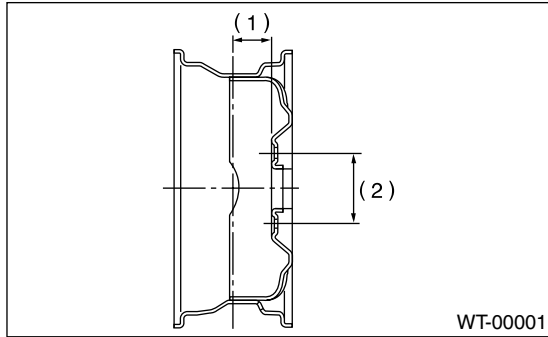

(1) Offset

(2) P.C.D.

Specifications		Tire size	Rim size	Rim offset mm (in)	P.C.D. mm (in)
Front and rear	TS	P195/60R15 87H	15 × 6JJ	55 (2.17)	100 (3.94)
	RS, OBK, WRX	P205/55R16 89V	16 × 6 1/2JJ		
	WRX: OPTION	215/45R17 87W	17 × 7JJ	55 (2.17)	
	STi	225/45R17 90W	17 × 7 1/2JJ	53 (2.09)	
T-type tire	TS, RS, OBK, WRX	T135/70D16 100M	16 × 4T	50 (1.97)	
	STi	T135/70D17 102M	17 × 4T	40 (1.57)	

Specifications		Tire size	Tire air pressure kPa (kgf/cm <sup>2</sup> , psi)
Front and rear	TS	P195/60R15 87H	Fr: 220 (2.2, 32) Rr: 200 (2.0, 29)
	RS, OBK, WRX	P205/55R16 89V	
	WRX: OPTION	215/45R17 87W	Fr: 230 (2.3, 33) Rr: 220 (2.2, 32)
	STi	225/45R17 90W	Fr: 250 (2.5, 36) Rr: 210 (2.1, 30)
T-type tire	TS, RS, OBK, WRX	T135/70D16 100M	420 (4.2, 60)
	STi	T135/70D17 102M	

**NOTE:**

“T-type” tire for temporary use is supplied as a spare tire.

# GENERAL DESCRIPTION

## WHEEL AND TIRE SYSTEM

### 1. SERVICE DATA

Item	Axial runout	Radial runout
Steel wheel	1.5 mm (0.059 in)	
Aluminum wheel	1.0 mm (0.039 in)	

### 2. ADJUSTING PARTS

Wheel balance	Standard	Service limit
Dynamic unbalance	Less than 5 g (0.18 oz)	

Balance weight part number (For steel wheel)	Weight
28101TC000	5 g (0.18 oz)
28101SA060	10 g (0.35 oz)
28101SA070	15 g (0.53 oz)
28101SA080	20 g (0.71 oz)
28101SA090	25 g (0.88 oz)
723141340	30 g (1.06 oz)
723141350	35 g (1.23 oz)
723141360	40 g (1.41 oz)
723141370	45 g (1.59 oz)
723241380	50 g (1.76 oz)
723241580	55 g (1.94 oz)
723241590	60 g (2.12 oz)

Balance weight part number (For aluminum wheel)	Weight
28101SA000	5 g (0.18 oz)
28101SA010	10 g (0.35 oz)
28101SA020	15 g (0.53 oz)
28101SA030	20 g (0.71 oz)
28101SA040	25 g (0.88 oz)
23141GA512	30 g (1.06 oz)
23141GA522	35 g (1.23 oz)
23141GA532	40 g (1.41 oz)
23141GA542	45 g (1.59 oz)
23141GA552	50 g (1.76 oz)
—	55 g (1.94 oz)
23141GA572	60 g (2.12 oz)

## B: PREPARATION TOOL

### 1. GENERAL PURPOSE TOOLS

TOOL NAME	REMARKS
Air pressure gauge	Used for measuring tire air pressure.
Dial gauge	Used for measuring wheel runout.

## 2. Tire

### A: INSPECTION

- 1) Take stone, glass, nail etc. off from tread groove.
- 2) Replace the tire if as follows.

#### CAUTION:

**When replacing a tire, make sure to use only the same size, construction and load range tire as originally installed.**

- (1) When a large crack on the side wall, damage or a crack on tread are found.
- (2) When the "tread wear indicator" appears as a solid band across the tread.

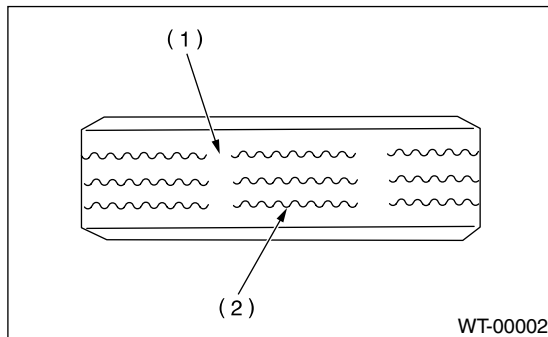

- (1) Tread wear indicator
- (2) Tire tread

- 3) When a crack on tire valve is found, replace the tire valve.

### 1. TIRE ROTATION

Rotate tires periodically (12,500 km/7,500 miles) as shown in the figure, in order to prevent them from uneven wear and to prolong their life.

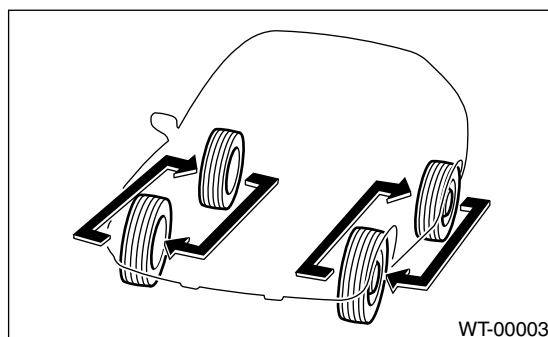

### 3. Steel Wheel

#### A: REMOVAL

- 1) Apply parking brake, and position the select lever to "P" or "LOW".
- 2) Set jacks or a lift to the specified point, and support the vehicle with its wheels slightly contacting the floor.
- 3) Loosen the wheel nuts.
- 4) Raise the vehicle until its wheels take off the ground using a jack or a lift.
- 5) Remove the wheel nuts and wheels.

#### NOTE:

- While removing the wheels, prevent the hub bolts from damage.
- Place the wheels with their outer sides facing upward to prevent the wheels from damage.

#### B: INSTALLATION

- 1) Remove dirt from the mating surface of wheel and brake rotor.
- 2) Attach the wheel to hub by aligning the wheel bolt hole with hub bolt.
- 3) Temporarily attach the wheel nuts to hub bolts. (In the case of aluminum wheel, use SUBARU genuine wheel nut for aluminum wheel.)
- 4) Manually tighten the nuts making sure the wheel hub hole is aligned correctly to guide portion of hub.
- 5) Tighten the wheel nuts in a diagonal selection to specified torque. Use a wheel nut wrench.

#### Wheel nut tightening torque:

**90 N·m (9.1 kgf·m, 65.7 ft·lb)**

#### CAUTION:

- Tighten the wheel nuts in two or three steps by gradually increasing the torque and working diagonally, until the specified torque is reached. For drum brake models, excess tightening of wheel nuts may cause wheels to "judder".
- Do not depress the wrench with foot; Always use both hands when tightening.
- Make sure the bolt, nut and nut seating surface of the wheel are free from oils.

- 6) If a wheel is removed for replacement or for repair of a puncture, retighten the wheel nuts to the specified torque after running 1,000 km (600 miles).

#### C: INSPECTION

- 1) Deformation or damage on the rim can cause air leakage. Check the rim flange for deformation, crack or damage, and repair or replace as necessary.
- 2) Jack-up the vehicle until wheels clear the floor.
- 3) Slowly rotate the wheel to check the rim "runout" using a dial gauge.

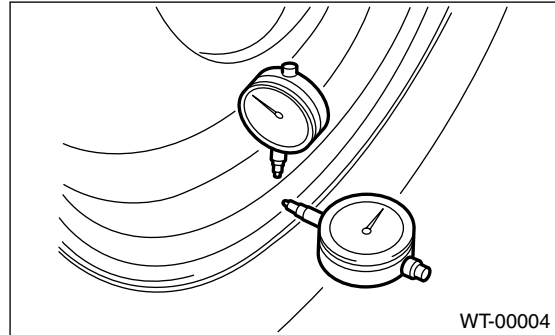

Axial runout limit	Radial runout limit
1.5 mm (0.059 in)	

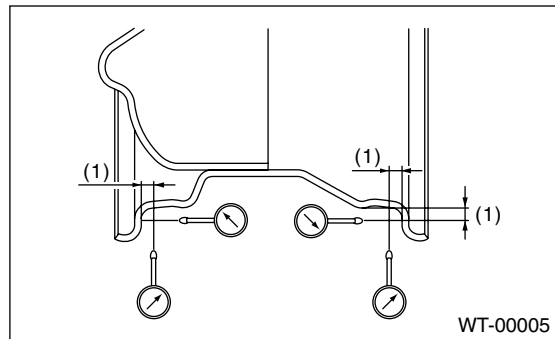

(1) Approx. 7 mm (0.28 in)

- 4) If the rim runout exceeds specifications, remove the tire from rim and check runout while attaching the dial gauge to positions shown in the figure.
- 5) If the measured runout still exceeds specifications, replace the wheel.

## 4. Aluminum Wheel

### A: REMOVAL

Refer to Steel Wheel for removal procedure of aluminum wheels. <Ref. to WT-5, REMOVAL, Steel Wheel.>

### B: INSTALLATION

Refer to Steel Wheel for installation procedure of aluminum wheels. <Ref. to WT-5, INSTALLATION, Steel Wheel.>

### C: INSPECTION

Refer to Steel Wheel for inspection procedure of aluminum wheels. <Ref. to WT-5, INSPECTION, Steel Wheel.>

#### *Rim runout:*

Axial runout limit	Radial runout limit
1.0 mm (0.039 in)	

### D: CAUTION

Aluminum wheels are easily scratched. To maintain their appearance and safety, do the following:

- 1) Do not damage the aluminum wheels during removal, installation, wheel balancing, etc. After removing the aluminum wheels, place them on a rubber mat, etc.
- 2) While the vehicle is being driven, be careful not to ride over sharp obstacles or allow the aluminum wheels to contact the shoulder of road.
- 3) When installing a tire chain, be sure to install it properly not to have slack; otherwise it may hit the wheel while driving.
- 4) When washing the aluminum wheel, use neutral synthetic detergent and water. Avoid using the cleanser including abrasive, hard brushes or an automatic car washer.

## 5. Wheel Balancing

### A: REPLACEMENT

- 1) Remove the balance weights.
- 2) Using wheel balancer, measure the wheel balance.
- 3) Select a weight close to the value measured by wheel balancer.

Balance weight part number (For steel wheel)	Weight
28101TC000	5 g (0.18 oz)
28101SA060	10 g (0.35 oz)
28101SA070	15 g (0.53 oz)
28101SA080	20 g (0.71 oz)
28101SA090	25 g (0.88 oz)
723141340	30 g (1.06 oz)
723141350	35 g (1.23 oz)
723141360	40 g (1.41 oz)
723141370	45 g (1.59 oz)
723241380	50 g (1.76 oz)
723241580	55 g (1.94 oz)
723241590	60 g (2.12 oz)

Balance weight part number (For aluminum wheel)	Weight
28101SA000	5 g (0.18 oz)
28101SA010	10 g (0.35 oz)
28101SA020	15 g (0.53 oz)
28101SA030	20 g (0.71 oz)
28101SA040	25 g (0.88 oz)
23141GA512	30 g (1.06 oz)
23141GA522	35 g (1.23 oz)
23141GA532	40 g (1.41 oz)
23141GA542	45 g (1.59 oz)
23141GA552	50 g (1.76 oz)
—	55 g (1.94 oz)
23141GA572	60 g (2.12 oz)

- 4) Install the selected weight to the point designated by wheel balancer.
- 5) Using wheel balancer, measure the wheel balance again. Check the wheel balance is correctly adjusted.

### B: INSPECTION

- 1) Proper wheel balance may be lost if the tire is repaired or if it wears. Check the tire for dynamic balance, and repair as necessary.
- 2) To check for dynamic balance, use a wheel balancer. Drive in the balance weight on both the top and rear sides of rim.
- 3) Some types of balancer can cause damage to the wheel. Use an appropriate balancer when adjusting the wheel balance.
- 4) Use genuine balance weights.

#### NOTE:

- 55 g (1.94 oz) weight used with the aluminum wheel is not available.
- Balance weights are available for use with any of 15 to 17-inch wheels.

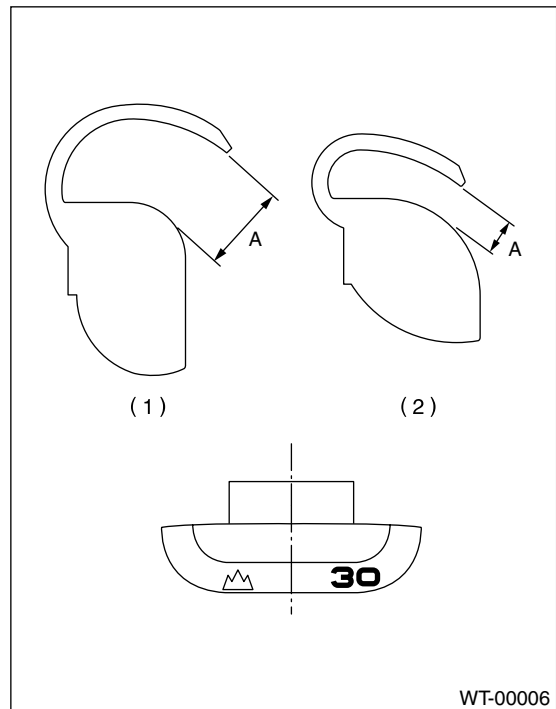

- (1) Weight for aluminum wheel
- (2) Weight for steel wheel

#### Service limit: A

##### Weight for steel wheel;

**5 g (0.18 oz) — 25 g (0.88 oz) 2.0 mm (0.08 in)**

**30 g (1.06 oz) or more 1.8 mm (0.07)**

##### Weight for aluminum wheel;

**5 g (0.18 oz) — 25 g (0.88 oz) 5.0 mm (0.20 in)**

**30 g (1.06 oz) or more 4.5 mm (0.177 in)**

## **6. “T-type” Tire**

### **A: NOTE**

“T-type” tire for temporary use is prepared as a spare tire.

### **CAUTION:**

- **Do not use a tire chain with the “T-type” tire. Because of the smaller tire size, a tire chain will not fit properly and will result in damage to the vehicle and the tire.**
- **Do not drive at a speed greater than 80 km/h (50 MPH).**
- **Drive as slowly as possible and avoid passing over bumps.**

### **B: REPLACEMENT**

Refer to Removal and Installation of Steel Wheel for removal/installation of “T-type” tires. <Ref. to WT-5, Steel Wheel.>

### **CAUTION:**

**Replace with a conventional tire as soon as possible since the “T-type” tire is only for temporary use.**

### **C: INSPECTION**

1) Check the tire inflation pressure.

#### ***Specification:***

***420 kPa (4.2 kg/cm<sup>2</sup>, 60 psi)***

- 2) Take stones, glass, nails, etc. out of the tread groove.
- 3) Check the tires for deformation, cracks, partial or over limit wear.

### **CAUTION:**

**Replace the tire with a new one.**



## 7. Full Wheel Cap

### A: REMOVAL

Pry off the full wheel cap with a wheel cap remover inserted between openings on cap.

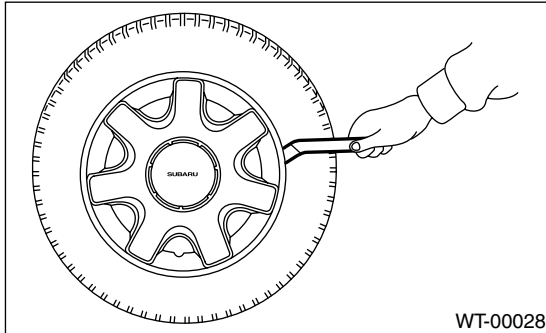

### B: INSTALLATION

Align the valve hole in wheel cap with the valve on wheel and secure the wheel cap by tapping four points by hand.

### C: INSPECTION

- 1) Check the wheels for missing wheel caps.
- 2) Check the pawls of wheel caps for damage or bend.
- 3) Check the wheel caps for cracks.

# GENERAL DIAGNOSTICS TABLE

## WHEEL AND TIRE SYSTEM

### 8. General Diagnostics Table

#### A: INSPECTION

Symptom	Possible cause	Remedy
Front wheel shimmy	Worn or improperly inflated tire.	In case of worn tire, replace the tire. In case of improperly inflated tire, adjust the tire air pressure properly.
	Wheel is out of balance.	Adjustment
Abnormal tire wear	Improperly inflated tire.	Replace
Sways/pitches	Worn or improperly inflated tire.	In case of worn tire, replace the tire. In case of improperly inflated tire, adjust the tire air pressure properly.
Wander/pulls	Worn or improperly inflated tire.	In case of worn tire, replace the tire. In case of improperly inflated tire, adjust the tire air pressure properly.