

Brought to you by Eris Studios
NOT FOR RESALE

COOLING

General Description

COOLING

1. General Description

A: SPECIFICATIONS

Model		DOHC TURBO		
Cooling system		Electric fan + Forced engine coolant circulation system		
Total engine coolant capacity		ℓ (US qt, Imp qt)		
		AT: Approx. 7.6 (8.03, 6.69) MT: Approx. 7.7 (8.14, 6.78)		
Water pump	Type	Centrifugal impeller type		
	Discharge performance I	Discharge	20 ℓ (5.3 US gal, 4.4 Imp gal)/min.	
		Pump speed — Discharge pressure	760 rpm — 2.9 kPa (0.3 mAq)	
		Engine coolant temperature	85°C (185°F)	
	Discharge performance II	Discharge	100 ℓ (26.4 US gal, 22.0 Imp gal)/min.	
		Pump speed — Discharge pressure	3,000 rpm — 49.0 kPa (5.0 mAq)	
		Engine coolant temperature	85°C (185°F)	
	Discharge performance III	Discharge	200 ℓ (52.8 US gal, 44.0 Imp gal)/min.	
		Pump speed — Discharge pressure	6,000 rpm — 225.4 kPa (23.0 mAq)	
		Engine coolant temperature	85°C (185°F)	
	Impeller diameter		76 mm (2.99 in)	
	Number of impeller vanes		8	
	Pump pulley diameter		60 mm (2.36 in)	
Clearance between impeller and case	Standard	0.5 — 0.7 mm (0.020 — 0.028 in)		
	Limit	1.0 mm (0.039 in)		
"Thrust" runout of impeller end		0.5 mm (0.020 in)		
Thermostat	Type	Wax pellet type		
	Starts to open	76 — 80°C (169 — 176°F)		
	Fully opened	91°C (196°F)		
	Valve lift	9.0 mm (0.354 in) or more/91°C (196°F)		
	Valve bore	35 mm (1.38 in)		
Radiator fan	Motor	Main fan	120 W	
		Sub fan	120 W	
	Fan diameter × Blade		320 mm (12.60 in) × 5 (main fan) 320 mm (12.60 in) × 7 (sub fan)	
Radiator	Type	Down flow, pressure type		
	Core dimensions	Width × Height × Thickness		
	Pressure range in which cap valve is open	Coolant filler tank side	Above: 108±15 kPa (1.1±0.15 kg/cm ² , 16±2 psi) Below: -1.0 to -4.9 kPa (-0.01 to -0.05 kg/cm ² , -0.1 to -0.7 psi)	
		Radiator side	Above only: 137±14.7 kPa (1.40±0.15 kg/cm ² , 20±2.1 psi)	
	Fins		Corrugated fin type	
Reservoir tank	Capacity	0.5 ℓ (0.5 US qt, 0.4 Imp qt)		

B: COMPONENT

1. WATER PUMP

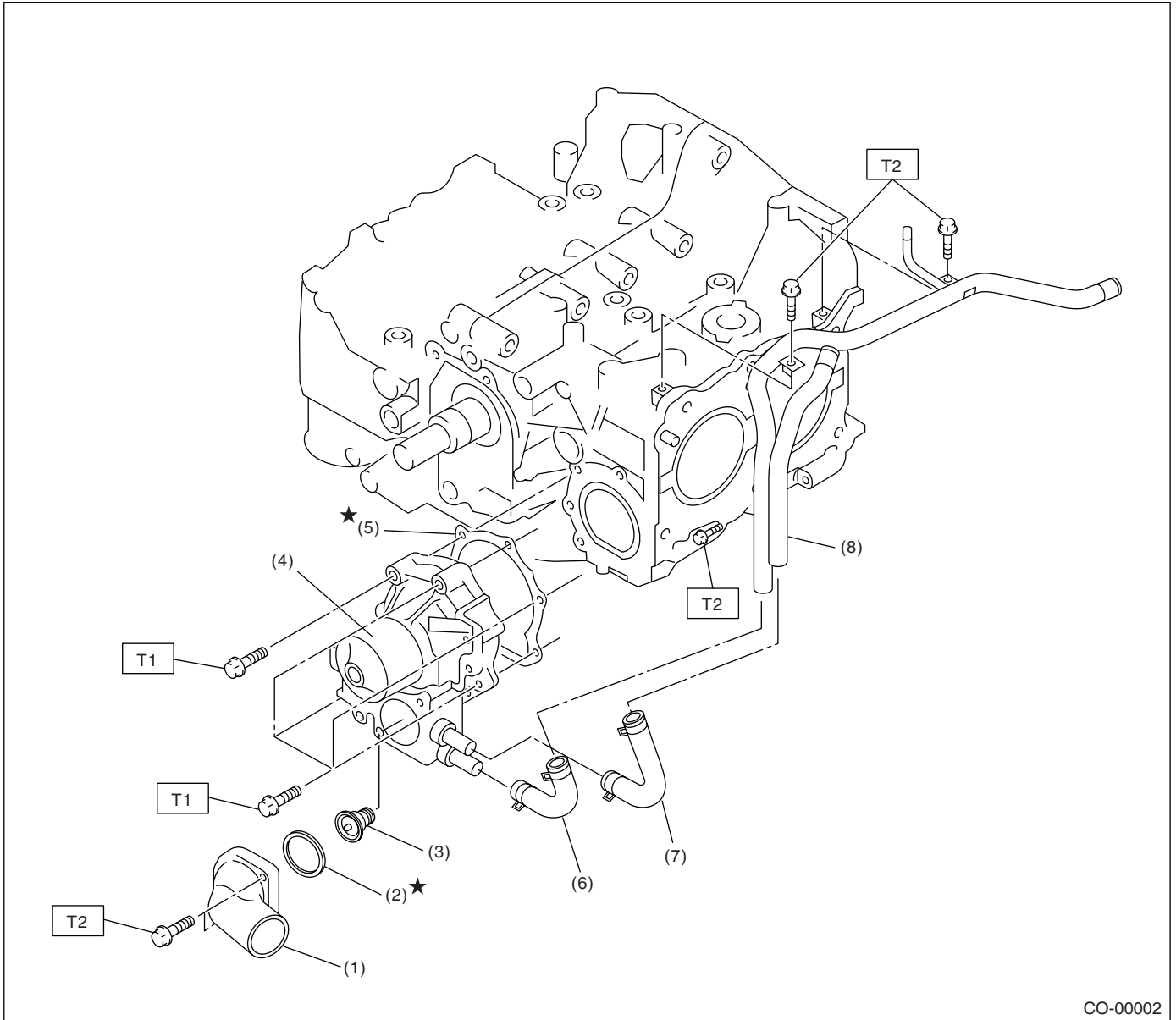

CO-00002

- | | |
|----------------------|--------------------------------------|
| (1) Thermostat cover | (5) Gasket |
| (2) Gasket | (6) Heater by-pass hose |
| (3) Thermostat | (7) Coolant filler tank by-pass hose |
| (4) Water pump ASSY | (8) Water by-pass pipe |

Tightening torque: N-m (kgf-m, ft-lb)
T1: First 12 (1.2, 8.7)
Second 12 (1.2, 8.7)
T2: 6.5 (0.66, 4.8)

General Description

COOLING

2. RADIATOR AND RADIATOR FAN

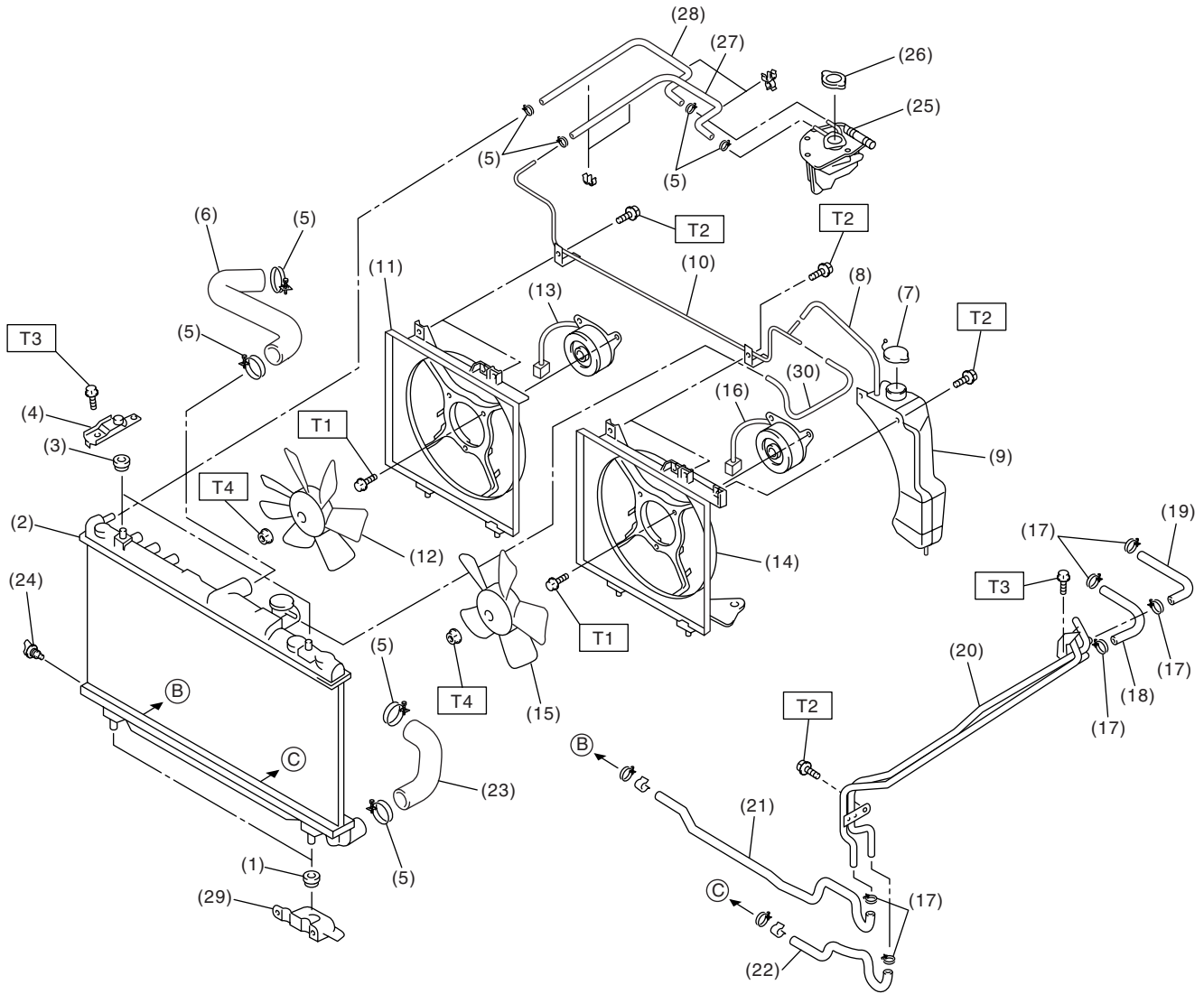

CO-00242

CO(H4DOTC)-4

General Description

COOLING

(1) Radiator lower cushion	(14) Radiator main fan shroud	(26) Radiator cap (engine coolant filler tank cap)
(2) Radiator	(15) Radiator main fan	(27) Engine overflow hose
(3) Radiator upper cushion	(16) Radiator main fan motor	(28) Engine air breather hose
(4) Radiator upper bracket	(17) ATF hose clamp (AT model)	(29) Radiator lower bracket
(5) Clamp	(18) ATF inlet hose A (AT model)	(30) Overflow hose B
(6) Radiator inlet hose	(19) ATF outlet hose A (AT model)	
(7) Engine coolant reservoir tank cap	(20) ATF pipe (AT model)	
(8) Overflow hose A	(21) ATF inlet hose B (AT model)	
(9) Engine coolant reservoir tank	(22) ATF outlet hose B (AT model)	
(10) Overflow pipe	(23) Radiator outlet hose	
(11) Radiator sub fan shroud	(24) Radiator drain plug	
(12) Radiator sub fan	(25) Engine coolant filler tank	
(13) Radiator sub fan motor		

Tightening torque: N-m (kgf-m, ft-lb)

T1: 4.4 (0.45, 3.3)

T2: 7.5 (0.76, 5.5)

T3: 18 (1.8, 13.0)

T4: 3.4 (0.35, 2.5)

C: CAUTION

- Wear working clothing, including a cap, protective goggles, and protective shoes during operation.
- Remove contamination including dirt and corrosion before removal, installation or disassembly.
- Keep the disassembled parts in order and protect them from dust or dirt.
- Before removal, installation or disassembly, be sure to clarify the failure. Avoid unnecessary removal, installation, disassembly, and replacement.
- Be careful not to burn your hands, because each part in the vehicle is hot after running.
- Be sure to tighten fasteners including bolts and nuts to the specified torque.
- Place shop jacks or safety stands at the specified points.
- Before disconnecting electrical connectors of sensors or units, be sure to disconnect the ground cable from battery.

General Description

COOLING

Brought to you by Eris Studios
NOT FOR RESALE

D: PREPARATION TOOL

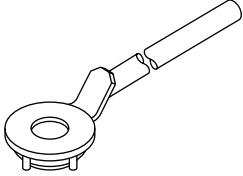
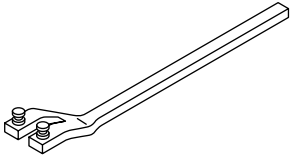
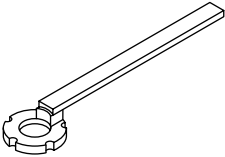
ILLUSTRATION	TOOL NUMBER	DESCRIPTION	REMARKS
 ST-499977400	49 9977400	CRANKSHAFT PULLEY WRENCH	Used for stopping crankshaft pulley when loosening and tightening crankshaft pulley bolts.
 ST18231AA010	18231AA010	CAMSHAFT SPROCKET WRENCH	Used for removing and installing intake camshaft sprocket.
 ST-499207400	499207400	CAMSHAFT SPROCKET WRENCH	Used for removing and installing exhaust camshaft sprocket.

2. Radiator Main Fan System

A: WIRING DIAGRAM

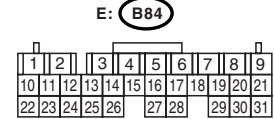
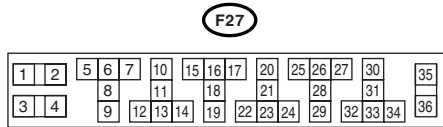
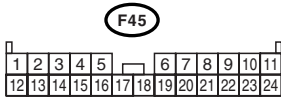
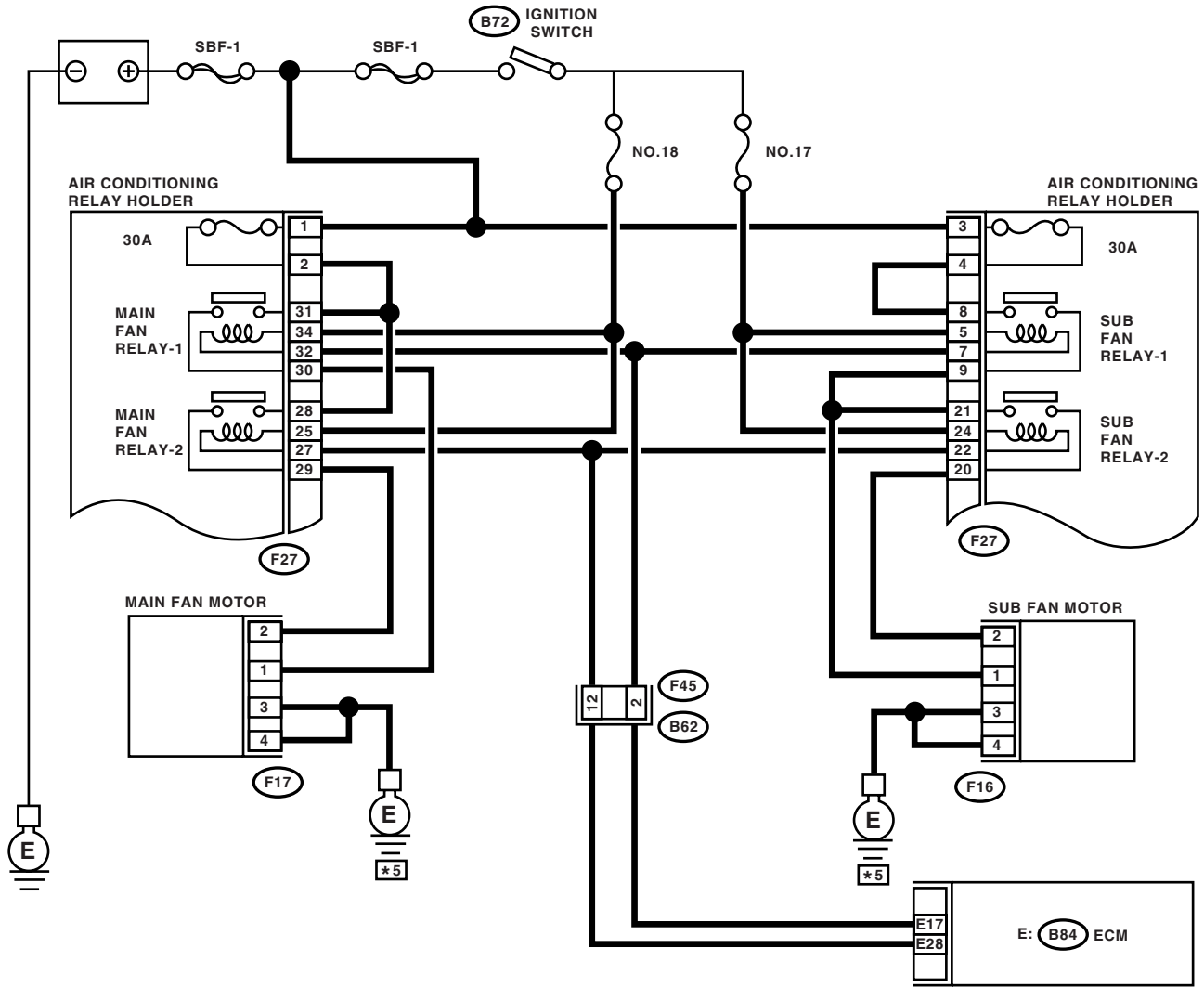

RELAY HOLDER

Radiator Main Fan System

COOLING

B: INSPECTION

DETECTING CONDITION:

- Engine coolant temperature is above 96°C (205°F).
- A/C compressor is rotated.
- Vehicle speed is below 19 km/h (12 MPH).

TROUBLE SYMPTOM:

- Radiator main fan does not rotate under the above conditions.
- Radiator main fan does not rotate at high speed when the following conditions are both met:
 - (1) Engine coolant temperature is above 90°C (194°F).
 - (2) A/C is ON.

	Step	Check	Yes	No
1	CHECK OPERATION OF RADIATOR. 1) Run the engine at idle. (Vehicle stationary) 2) Turn the A/C switch to OFF. 3) Warm the engine coolant temperature over 96°C (205°F).	Does the main radiator fan rotate?	Go to step 2.	Go to step 3.
2	CHECK OPERATION OF RADIATOR. Turn the A/C switch to ON at condition of step 1.	Does the main radiator fan rotate faster when A/C compressor is operated?	Radiator main fan system is okay.	Go to step 17.
3	CHECK POWER SUPPLY TO MAIN FAN MOTOR. CAUTION: Be careful not to overheat the engine during repair. 1) Turn the ignition switch to OFF. 2) Disconnect the connector from main fan motor. 3) Start the engine, and warm it up until engine coolant temperature increases over 96°C (205°F). 4) Stop the engine and turn ignition switch to ON. 5) Measure the voltage between main fan motor connector and chassis ground. Connector & terminal (F17) No. 1 (+) — Chassis ground (-):	Is the voltage more than 10 V?	Go to step 4.	Go to step 7.
4	CHECK GROUND CIRCUIT OF MAIN FAN MOTOR. 1) Turn the ignition switch to OFF. 2) Measure the resistance between main fan motor connector and chassis ground. Connector & terminal (F17) No. 3 — Chassis ground: (F17) No. 4 — Chassis ground:	Is the resistance less than 5 Ω?	Go to step 5.	Repair the open circuit in harness between main fan motor connector and chassis ground.
5	CHECK POOR CONTACT. Check poor contact in main fan motor connector.	Is there poor contact in main fan motor connector?	Repair the poor contact in main fan motor connector.	Go to step 6.
6	CHECK MAIN FAN MOTOR. Connect the battery positive (+) terminal to terminal No. 1, and ground (-) terminal to terminal No. 3 or No. 4 of main fan motor connector.	Does the main fan rotate?	Repair the poor contact in main fan motor connector.	Replace the main fan motor with a new one.

Radiator Main Fan System

COOLING

Step	Check	Yes	No
7 CHECK POWER SUPPLY TO MAIN FAN RELAY1. 1) Turn the ignition switch to OFF. 2) Remove the main fan relay1 from A/C relay holder. 3) Measure the voltage between main fan relay1 terminal and chassis ground. Connector & terminal (F27) No. 31 (+) — Chassis ground (-):	Is the voltage more than 10 V?	Go to step 8.	Go to step 9.
8 CHECK POWER SUPPLY TO MAIN FAN RELAY1. 1) Turn the ignition switch to ON. 2) Measure the voltage between main fan relay1 terminal and chassis ground. Connector & terminal (F27) No. 34 (+) — Chassis ground (-):	Is the voltage more than 10 V?	Go to step 12.	Go to step 11.
9 CHECK 30 A FUSE. 1) Remove the 30 A fuse from A/C relay holder. 2) Check the condition of fuse.	Is the fuse blown out?	Replace the fuse.	Go to step 10.
10 CHECK POWER SUPPLY TO A/C RELAY HOLDER 30 A FUSE TERMINAL. Measure the voltage of harness between A/C relay holder 30 A fuse terminal and chassis ground. Connector & terminal (F27) No. 1 (+) — Chassis ground (-):	Is the voltage more than 10 V?	Repair the open circuit in harness between 30 A fuse and main fan relay terminal.	Repair the open circuit in harness between main fuse box connector and 30 A fuse terminal.
11 CHECK FUSE. 1) Turn the ignition switch to OFF. 2) Remove the fuse No. 18 from joint box. 3) Check the condition of fuse.	Is the fuse blown out?	Replace the fuse.	Repair the open circuit in harness between main fan relay and ignition switch.
12 CHECK MAIN FAN RELAY. 1) Turn the ignition switch to OFF. 2) Remove the main fan relay1. 3) Measure the resistance of main fan relay1. Terminals No. 30 — No. 31:	Is the resistance more than 1 M Ω ?	Go to step 13.	Replace the main fan relay.
13 CHECK MAIN FAN RELAY. 1) Connect the battery to terminals No. 27 and No. 28 of main fan relay1. 2) Measure the resistance of main fan relay1. Terminals No. 30 — No. 31:	Is the resistance less than 1 Ω ?	Go to step 14.	Replace the main fan relay.
14 CHECK HARNESS BETWEEN MAIN FAN RELAY TERMINAL AND MAIN FAN MOTOR CONNECTOR. Measure the resistance of harness between main fan motor connector and main fan relay terminal. Connector & terminal (F17) No. 1 — (F27) No. 30:	Is the resistance less than 1 Ω ?	Go to step 15.	Repair the open circuit in harness between main fan motor connector and main fan relay terminal.

Radiator Main Fan System

COOLING

Step	Check	Yes	No
15 CHECK HARNESS BETWEEN MAIN FAN RELAY AND ECM. 1) Turn the ignition switch to OFF. 2) Disconnect the connector from ECM. 3) Measure the resistance of harness between main fan relay connector and ECM connector. <i>Connector & terminal</i> <i>(F27) No. 32 — (B84) No. 17:</i>	Is the resistance less than 1 Ω ?	Go to step 16.	Repair the open circuit in harness between main fan relay and ECM.
16 CHECK POOR CONTACT. Check poor contact in connector between main fan and ECM.	Is there poor contact in connector between main fan motor and ECM?	Repair the poor contact connector.	Record the DTC. Repair the trouble cause. <Ref. to EN(H4DOTC)(diag)-38, Read Diagnostic Trouble Code (DTC).>
17 CHECK POWER SUPPLY TO MAIN FAN MOTOR. CAUTION: Be careful not to overheat the engine during repair. 1) Turn the ignition switch to OFF. 2) Disconnect the connector from main fan motor. 3) Start the engine, and warm it up until engine coolant temperature increases over 96°C (205°F). 4) Turn the A/C switch ON. 5) Measure the voltage while A/C compressor is rotating. 6) Measure the voltage between main fan motor connector and chassis ground. <i>Connector & terminal</i> <i>(F17) No. 2 (+) — Chassis ground (-):</i>	Is the voltage more than 10 V?	Go to step 18.	Go to step 20.
18 CHECK POOR CONTACT. Check poor contact in main fan motor connector.	Is there poor contact in main fan motor connector?	Repair the poor contact in main fan motor connector.	Go to step 19.
19 CHECK MAIN FAN MOTOR. Connect the battery positive (+) terminal to terminal No. 2, and ground (-) terminal to terminal No. 1 of main fan motor connector.	Does the main fan rotate?	Repair the poor contact in main fan motor connector.	Replace the main fan motor with a new one.
20 CHECK POWER SUPPLY TO MAIN FAN RELAY2. 1) Turn the ignition switch to OFF. 2) Remove the main fan relay2 from A/C relay holder. 3) Measure the voltage between main fan relay2 terminal and chassis ground. <i>Connector & terminal</i> <i>(F27) No. 28 (+) — Chassis ground (-):</i>	Is the voltage more than 10 V?	Go to step 21.	Go to step 22.
21 CHECK POWER SUPPLY TO MAIN FAN RELAY2. 1) Turn the ignition switch to ON. 2) Measure the voltage between main fan relay2 terminal and chassis ground. <i>Connector & terminal</i> <i>(F27) No. 25 (+) — Chassis ground (-):</i>	Is the voltage more than 10 V?	Go to step 25.	Go to step 24.

Radiator Main Fan System

COOLING

Step	Check	Yes	No
22 CHECK 30 A FUSE. 1) Remove the 30 A fuse from A/C relay holder. 2) Check the condition of fuse.	Is the fuse blown out?	Replace the fuse.	Go to step 23.
23 CHECK POWER SUPPLY TO A/C RELAY HOLDER 30 A FUSE TERMINAL. Measure the voltage of harness between A/C relay holder 30 A fuse terminal and chassis ground. <i>Connector & terminal</i> <i>(F27) No. 1 (+) — Chassis ground (-):</i>	Is the voltage more than 10 V?	Repair the open circuit in harness between 30 A fuse and main fan relay terminal.	Repair the open circuit in harness between main fan box connector and 30 A fuse terminal.
24 CHECK FUSE. 1) Turn the ignition switch to OFF. 2) Remove the fuse No. 18 from joint box. 3) Check the condition of fuse.	Is the fuse blown out?	Replace the fuse.	Repair the open circuit in harness between main fan relay and ignition switch.
25 CHECK MAIN FAN RELAY. 1) Turn the ignition switch to OFF. 2) Remove the main fan relay. 3) Measure the resistance of main fan relay. <i>Terminals</i> <i>No. 28 — No. 29:</i>	Is the resistance more than 1 M Ω ?	Go to step 26.	Replace the main fan relay.
26 CHECK MAIN FAN RELAY. 1) Connect the battery to terminals No. 21 and No. 22 of main fan relay. 2) Measure the resistance of main fan relay. <i>Terminals</i> <i>No. 28 — No. 29:</i>	Is the resistance less than 1 Ω ?	Go to step 27.	Replace the main fan relay.
27 CHECK HARNESS BETWEEN MAIN FAN RELAY TERMINAL AND MAIN FAN MOTOR CONNECTOR. Measure the resistance of harness between main fan motor connector and main fan relay terminal. <i>Connector & terminal</i> <i>(F17) No. 2 — (F27) No. 29:</i>	Is the resistance less than 1 Ω ?	Go to step 28.	Repair the open circuit in harness between main fan motor connector and main fan relay terminal.
28 CHECK HARNESS BETWEEN MAIN FAN RELAY AND ECM. 1) Turn the ignition switch to OFF. 2) Disconnect the connector from ECM. 3) Measure the resistance of harness between main fan relay connector and ECM connector. <i>Connector & terminal</i> <i>(F27) No. 27 — (B84) No. 28:</i>	Is the resistance less than 1 Ω ?	Go to step 29.	Repair the open circuit in harness between main fan relay and ECM.
29 CHECK POOR CONTACT. Check poor contact in connector between main fan and ECM.	Is there poor contact in connector between main fan motor and ECM?	Repair the poor contact connector.	Record the DTC. Repair the trouble cause. <Ref. to EN(H4DOTC)(diag)-38, Read Diagnostic Trouble Code (DTC).>

Radiator Sub Fan System

COOLING

3. Radiator Sub Fan System

A: WIRING DIAGRAM

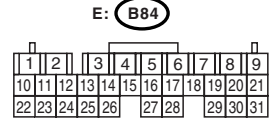
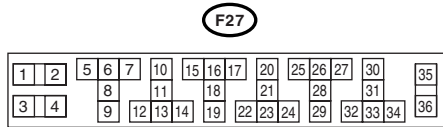
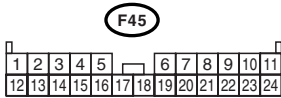
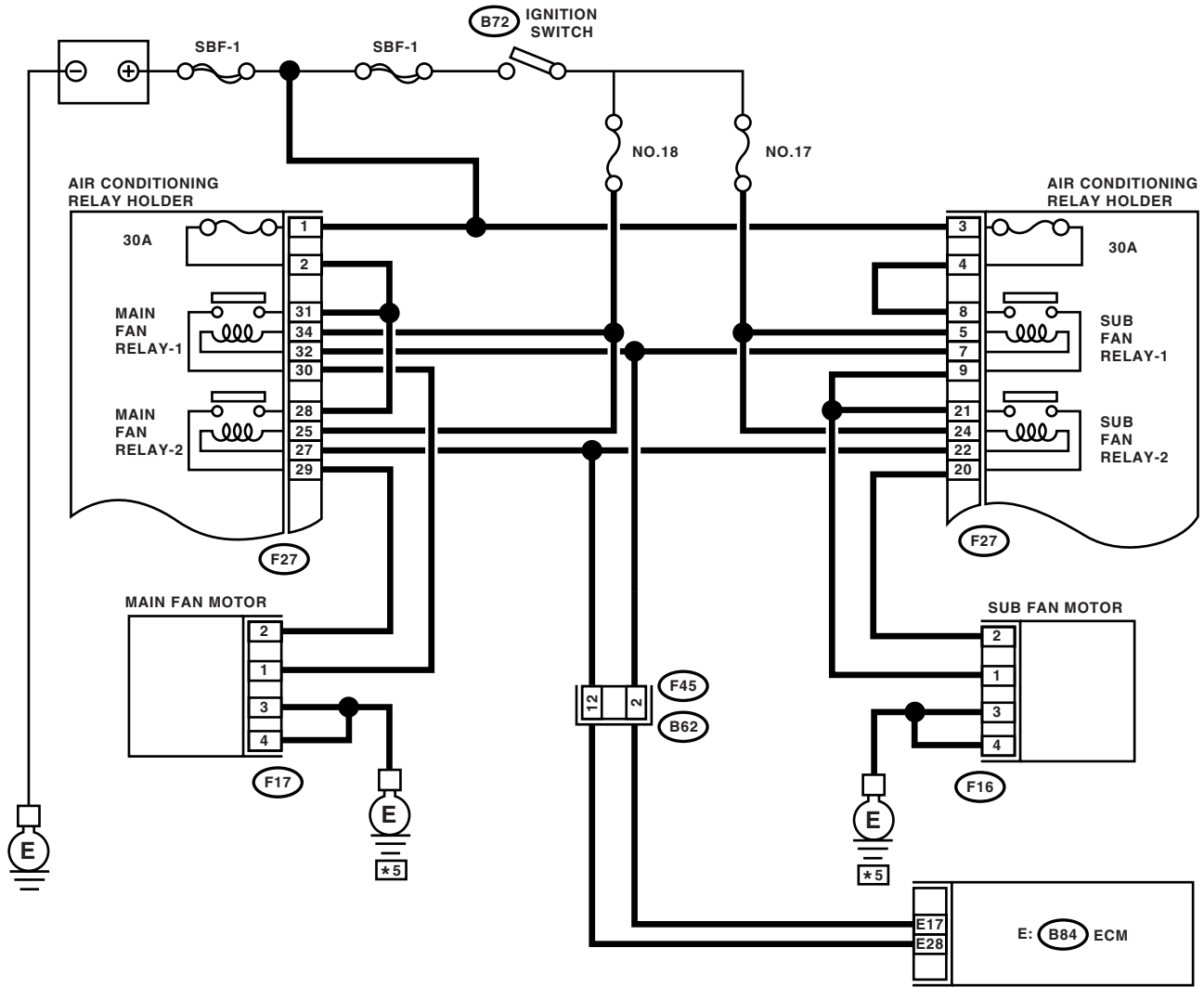

RELAY HOLDER

CO-00241

B: INSPECTION

DETECTING CONDITION:

- Engine coolant temperature is above 96°C (205°F).
- A/C compressor is rotated.
- Vehicle speed is below 19 km/h (12 MPH).

TROUBLE SYMPTOM:

- Radiator sub fan does not rotate under the above conditions.
- Radiator sub fan does not rotate at high speed when the following conditions are both met:
 - (1) Engine coolant temperature is above 90°C (194°F).
 - (2) A/C is ON.

Step	Check	Yes	No	
1	CHECK OPERATION OF RADIATOR. 1) Run the engine at idle. (Vehicle stationary) 2) Turn the A/C switch to OFF. 3) Warm the engine coolant temperature over 96°C (205°F).	Does the radiator sub fan rotate?	Go to step 2.	Go to step 3.
2	CHECK OPERATION OF RADIATOR. Turn the A/C switch to ON at condition of step 1.	Does the radiator sub fan rotate faster when A/C compressor is operated?	Radiator main fan system is okay.	Go to step 17.
3	CHECK POWER SUPPLY TO SUB FAN MOTOR. CAUTION: Be careful not to overheat the engine during repair. 1) Turn the ignition switch to OFF. 2) Disconnect the connector from sub fan motor. 3) Start the engine, and warm it up until engine coolant temperature increases over 96°C (205°F). 4) Stop the engine and turn ignition switch to ON. 5) Measure the voltage between sub fan motor connector and chassis ground. Connector & terminal (F16) No. 1 (+) — Chassis ground (-):	Is the voltage more than 10 V?	Go to step 4.	Go to step 7.
4	CHECK GROUND CIRCUIT OF SUB FAN MOTOR. 1) Turn the ignition switch to OFF. 2) Measure the resistance between sub fan motor connector and chassis ground. Connector & terminal (F16) No. 3 — Chassis ground: (F16) No. 4 — Chassis ground:	Is the resistance less than 5 Ω?	Go to step 5.	Repair the open circuit in harness between sub fan motor connector and chassis ground.
5	CHECK POOR CONTACT. Check poor contact in sub fan motor connector.	Is there poor contact in sub fan motor connector?	Repair the poor contact in sub fan motor connector.	Go to step 6.
6	CHECK MAIN FAN MOTOR. Connect the battery positive (+) terminal to terminal No. 1, and ground (-) terminal to terminal No. 3 or No. 4 of sub fan motor connector.	Does the main fan rotate?	Repair the poor contact in sub fan motor connector.	Replace the sub fan motor with a new one.

Radiator Sub Fan System

COOLING

Step	Check	Yes	No
7 CHECK POWER SUPPLY TO SUB FAN RELAY1. 1) Turn the ignition switch to OFF. 2) Remove the sub fan relay1 from A/C relay holder. 3) Measure the voltage between sub fan relay1 terminal and chassis ground. Connector & terminal (F27) No. 7 (+) — Chassis ground (-):	Is the voltage more than 10 V?	Go to step 8.	Go to step 9.
8 CHECK POWER SUPPLY TO SUB FAN RELAY1. 1) Turn the ignition switch to ON. 2) Measure the voltage between sub fan relay1 terminal and chassis ground. Connector & terminal (F27) No. 5 (+) — Chassis ground (-):	Is the voltage more than 10 V?	Go to step 12.	Go to step 11.
9 CHECK 30 A FUSE. 1) Remove the 30 A fuse from A/C relay holder. 2) Check the condition of fuse.	Is the fuse blown out?	Replace the fuse.	Go to step 10.
10 CHECK POWER SUPPLY TO A/C RELAY HOLDER 30 A FUSE TERMINAL. Measure the voltage of harness between A/C relay holder 30 A fuse terminal and chassis ground. Connector & terminal (F27) No. 3 (+) — Chassis ground (-):	Is the voltage more than 10 V?	Repair the open circuit in harness between 30 A fuse and sub fan relay terminal.	Repair the open circuit in harness between sub fuse box connector and 30 A fuse terminal.
11 CHECK FUSE. 1) Turn the ignition switch to OFF. 2) Remove the fuse No. 17 from joint box. 3) Check the condition of fuse.	Is the fuse blown out?	Replace the fuse.	Repair the open circuit in harness between sub fan relay and ignition switch.
12 CHECK SUB FAN RELAY. 1) Turn the ignition switch to OFF. 2) Remove the main fan relay1. 3) Measure the resistance of sub fan relay1. Terminals No. 7 — No. 8:	Is the resistance more than 1 M Ω ?	Go to step 13.	Replace the sub fan relay.
13 CHECK SUB FAN RELAY. 1) Connect the battery to terminals No. 6 and No. 5 of sub fan relay1. 2) Measure the resistance of sub fan relay. Terminals No. 7 — No. 8:	Is the resistance less than 1 Ω ?	Go to step 14.	Replace the sub fan relay.
14 CHECK HARNESS BETWEEN SUB FAN RELAY TERMINAL AND SUB FAN MOTOR CONNECTOR. Measure the resistance of harness between sub fan motor connector and sub fan relay terminal. Connector & terminal (F16) No. 1 — (F27) No. 9:	Is the resistance less than 1 Ω ?	Go to step 15.	Repair the open circuit in harness between sub fan motor connector and sub fan relay terminal.

Radiator Sub Fan System

COOLING

Step	Check	Yes	No
<p>15 CHECK HARNESS BETWEEN SUB FAN RELAY AND ECM. 1) Turn the ignition switch to OFF. 2) Disconnect the connector from ECM. 3) Measure the resistance of harness between sub fan relay connector and ECM connector. Connector & terminal (F27) No. 7 — (B84) No. 17:</p>	<p>Is the resistance less than 1 Ω?</p>	<p>Go to step 16.</p>	<p>Repair the open circuit in harness between sub fan relay and ECM.</p>
<p>16 CHECK POOR CONTACT. Check poor contact in connector between sub fan and ECM.</p>	<p>Is there poor contact in connector between sub fan motor and ECM?</p>	<p>Repair the poor contact connector.</p>	<p>Record the DTC. Repair the trouble cause. <Ref. to EN(H4DOTC)(diag)-38, Read Diagnostic Trouble Code (DTC).></p>
<p>17 CHECK POWER SUPPLY TO SUB FAN MOTOR. CAUTION: Be careful not to overheat the engine during repair. 1) Turn the ignition switch to OFF. 2) Disconnect the connector from sub fan motor. 3) Start the engine, and warm it up until engine coolant temperature increases over 96°C (205°F). 4) Turn the A/C switch ON. 5) Measure the voltage while A/C compressor is rotating. 6) Measure the voltage between sub fan motor connector and chassis ground. Connector & terminal (F16) No. 2 (+) — Chassis ground (-):</p>	<p>Is the voltage more than 10 V?</p>	<p>Go to step 18.</p>	<p>Go to step 20.</p>
<p>18 CHECK POOR CONTACT. Check poor contact in sub fan motor connector.</p>	<p>Is there poor contact in sub fan motor connector?</p>	<p>Repair the poor contact in sub fan motor connector.</p>	<p>Go to step 19.</p>
<p>19 CHECK SUB FAN MOTOR. Connect the battery positive (+) terminal to terminal No. 2, and ground (-) terminal to terminal No. 3 or No. 4 of sub fan motor connector.</p>	<p>Does the main fan rotate?</p>	<p>Repair the poor contact in sub fan motor connector.</p>	<p>Replace the sub fan motor with a new one.</p>
<p>20 CHECK POWER SUPPLY TO SUB FAN RELAY2. 1) Turn the ignition switch to OFF. 2) Remove the sub fan relay2 from A/C relay holder. 3) Measure the voltage between sub fan relay2 terminal and chassis ground. Connector & terminal (F27) No. 21 (+) — Chassis ground (-):</p>	<p>Is the voltage more than 10 V?</p>	<p>Go to step 21.</p>	<p>Go to step 22.</p>
<p>21 CHECK POWER SUPPLY TO SUB FAN RELAY2. 1) Turn the ignition switch to ON. 2) Measure the voltage between sub fan relay2 terminal and chassis ground. Connector & terminal (F27) No. 24 (+) — Chassis ground (-):</p>	<p>Is the voltage more than 10 V?</p>	<p>Go to step 23.</p>	<p>Go to step 24.</p>

Radiator Sub Fan System

COOLING

Step	Check	Yes	No
22 CHECK 30 A FUSE. 1) Remove the 30 A fuse from A/C relay holder. 2) Check the condition of fuse.	Is the fuse blown out?	Replace the fuse.	Go to step 23.
23 CHECK POWER SUPPLY TO A/C RELAY HOLDER 30 A FUSE TERMINAL. Measure the voltage of harness between A/C relay holder 30 A fuse terminal and chassis ground. <i>Connector & terminal</i> <i>(F27) No. 3 (+) — Chassis ground (-):</i>	Is the voltage more than 10 V?	Repair the open circuit in harness between 30 A fuse and sub fan relay terminal.	Repair the open circuit in harness between sub fuse box connector and 30 A fuse terminal.
24 CHECK FUSE. 1) Turn the ignition switch to OFF. 2) Remove the fuse No. 17 from joint box. 3) Check the condition of fuse.	Is the fuse blown out?	Replace the fuse.	Repair the open circuit in harness between sub fan relay and ignition switch.
25 CHECK SUB FAN RELAY. 1) Turn the ignition switch to OFF. 2) Remove the sub fan relay. 3) Measure the resistance of main fan relay. <i>Terminals</i> <i>No. 20 — No. 21:</i>	Is the resistance more than 1 M Ω ?	Go to step 26.	Replace the sub fan relay.
26 CHECK MAIN FAN RELAY. 1) Connect the battery to terminals No. 19 and No. 20 of sub fan relay. 2) Measure the resistance of main fan relay. <i>Terminals</i> <i>No. 20 — No. 21:</i>	Is the resistance less than 1 Ω ?	Go to step 27.	Replace the sub fan relay.
27 CHECK HARNESS BETWEEN SUB FAN RELAY TERMINAL AND SUB FAN MOTOR CONNECTOR. Measure the resistance of harness between sub fan motor connector and sub fan relay terminal. <i>Connector & terminal</i> <i>(F16) No. 2 — (F27) No. 20:</i>	Is the resistance less than 1 Ω ?	Go to step 28.	Repair the open circuit in harness between sub fan motor connector and sub fan relay terminal.
28 CHECK HARNESS BETWEEN SUB FAN RELAY AND ECM. 1) Turn the ignition switch to OFF. 2) Disconnect the connector from ECM. 3) Measure the resistance of harness between sub fan relay connector and ECM connector. <i>Connector & terminal</i> <i>(F27) No. 22 — (B84) No. 28:</i>	Is the resistance less than 1 Ω ?	Go to step 29.	Repair the open circuit in harness between sub fan relay and ECM.
29 CHECK POOR CONTACT. Check poor contact in connector between sub fan and ECM.	Is there poor contact in connector between sub fan motor and ECM?	Repair the poor contact connector.	Record the DTC. Repair the trouble cause. <Ref. to EN(H4DOTC)(diag)-38, Read Diagnostic Trouble Code (DTC).>

4. Engine Coolant

A: REPLACEMENT

1. DRAINING OF ENGINE COOLANT

- 1) Lift-up the vehicle.
- 2) Remove the under cover.
- 3) Remove the drain cock to drain engine coolant into container.

NOTE:

Remove the coolant filler tank cap so that engine coolant will drain faster.

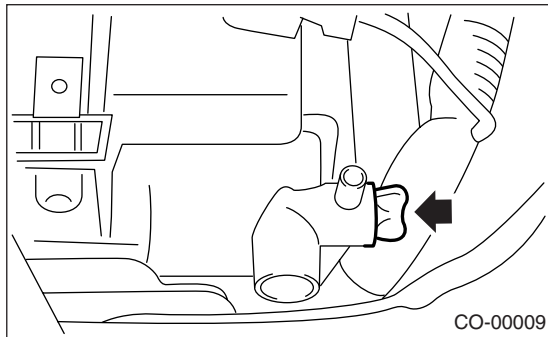

- 4) Install the drain cock.

2. FILLING OF ENGINE COOLANT

- 1) Fill engine coolant into the coolant filler tank up to filler neck position.

Coolant capacity (fill up to "FULL" level):

AT model

Approx. 7.6 ℓ (8.03 US qt, 6.69 Imp qt)

MT model

Approx. 7.7 ℓ (8.14 US qt, 6.78 Imp qt)

CAUTION:

Do not mix up the coolant filler tank side cap with radiator side cap.

NOTE:

- Do not remove the radiator side cap when filling engine coolant.
- The SUBARU Genuine Coolant containing anti-freeze and anti-rust agents is especially made for SUBARU engine, which has an aluminum crank-case. Always use SUBARU Genuine Coolant, since other coolant may cause corrosion.

- 2) Fill engine coolant into the reservoir tank up to Full level.

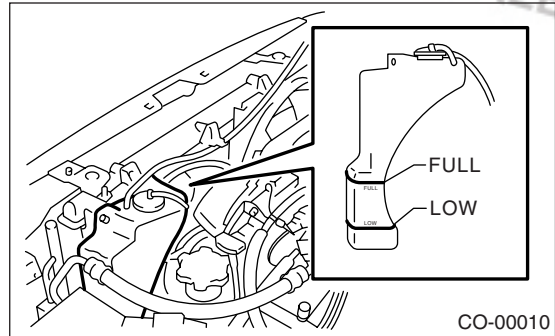

- 3) Warm-up the engine completely for more than 5 minutes at 2,000 to 3,000 rpm.
- 4) If the engine coolant level drops in coolant filler tank, add engine coolant to filler neck position.
- 5) If the engine coolant level drops from Full level of reservoir tank, add engine coolant to Full level.
- 6) Attach the coolant filler tank cap and reservoir tank cap properly.

B: INSPECTION

1. RELATIONSHIP OF SUBARU COOLANT CONCENTRATION AND FREEZING TEMPERATURE

The concentration and safe operating temperature of the SUBARU coolant is shown in the diagram. Measuring the temperature and specific gravity of the coolant will provide this information.

Engine Coolant

COOLING

[Example]

If the coolant temperature is 25°C (77°F) and its specific gravity is 1.054, the concentration is 45% (point A), the safe operating temperature is -14°C (7°F) (point B), and the freezing temperature is -20°C (-4°F) (point C).

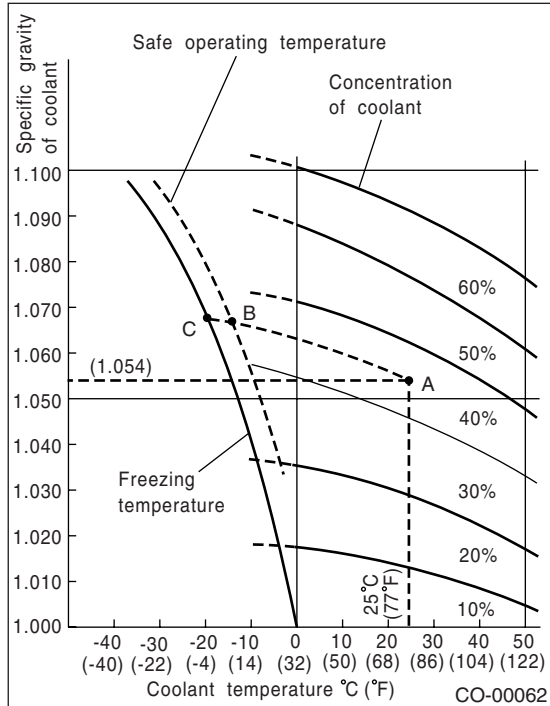

If a coolant concentration of 50% is needed, drain all the coolant and refill with the undiluted solution only.

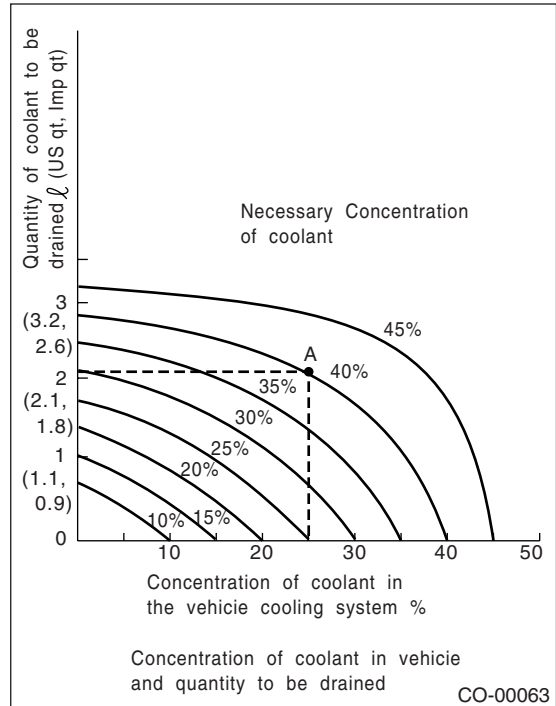

2. PROCEDURE TO ADJUST THE CONCENTRATION OF THE COOLANT

To adjust the concentration of the coolant according to temperature, find the proper fluid concentration in the above diagram and replace the necessary amount of coolant with an undiluted solution of SUBARU genuine coolant (concentration 50%).

The amount of coolant that should be replaced can be determined using the diagram.

[Example]

Assume that the coolant concentration must be increased from 25% to 40%. Find point A, where the 25% line of coolant concentration intersects with the 40% curve of the necessary coolant concentration, and read the scale on the vertical axis of the graph at height A. The quantity of coolant to be drained is 2.1 ℓ (2.2 US qt, 1.8 Imp qt). Drain 2.1 ℓ (2.2 US qt, 1.8 Imp qt) of coolant from the cooling system and add 2.1 ℓ (2.2 US qt, 1.8 Imp qt) of the undiluted solution of SUBARU coolant.

5. Water Pump

A: REMOVAL

- 1) Remove the radiator. <Ref. to CO(H4DOTC)-22, REMOVAL, Radiator.>
- 2) Remove the V-belts. <Ref. to ME(H4DOTC)-42, REMOVAL, V-belt.>
- 3) Remove the timing belt. <Ref. to ME(H4DOTC)-46, REMOVAL, Timing Belt Assembly.>
- 4) Remove the automatic belt tension adjuster (A).
- 5) Remove the belt idler (B).
- 6) Remove the belt idler No. 2 (C).

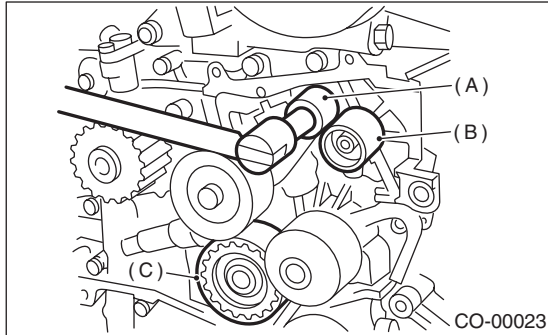

- 7) Remove the camshaft position sensor. <Ref. to FU(H4DOTC)-29, REMOVAL, Camshaft Position Sensor.>
- 8) Remove the camshaft sprockets (LH) by using ST. <Ref. to ME(H4DOTC)-54, REMOVAL, Camshaft Sprocket.>
- 9) Remove the belt cover No. 2 (LH).

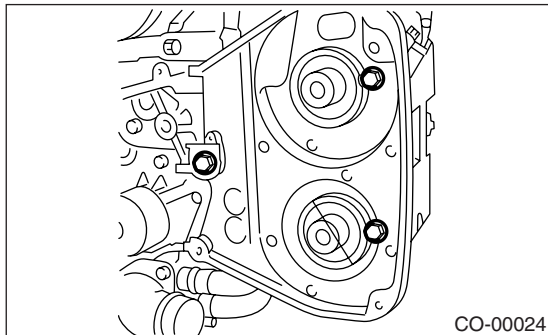

- 10) Remove the tensioner bracket.

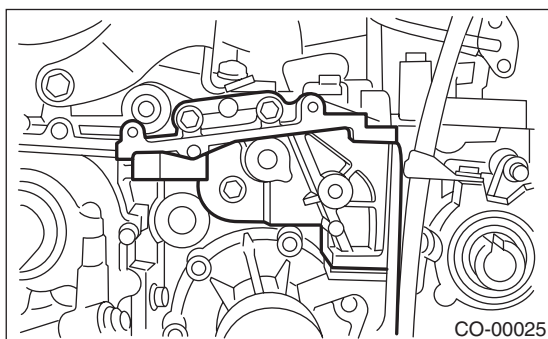

- 11) Disconnect the hose from water pump.

- 12) Remove the water pump.

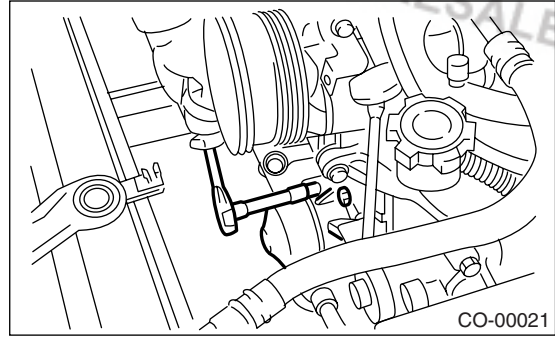

B: INSTALLATION

- 1) Install the water pump onto cylinder block (LH).

NOTE:

- Replace the gasket with a new one.
- When installing the water pump, tighten bolts in two stages in alphabetical sequence as shown in the figure.

Tightening torque:

First:

12 N·m (1.2 kgf-m, 8.7 ft-lb)

Second:

12 N·m (1.2 kgf-m, 8.7 ft-lb)

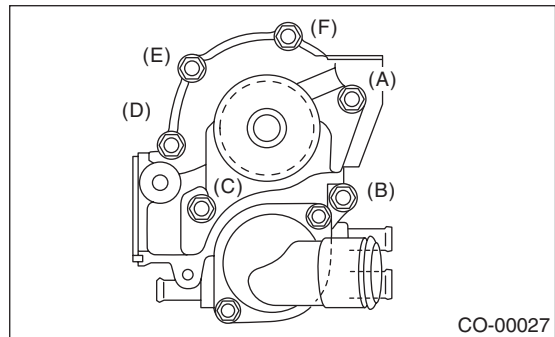

- 2) Connect the hose to water pump.
- 3) Install the tensioner bracket.

Tightening torque:

25 N·m (2.5 kgf-m, 18.1 ft-lb)

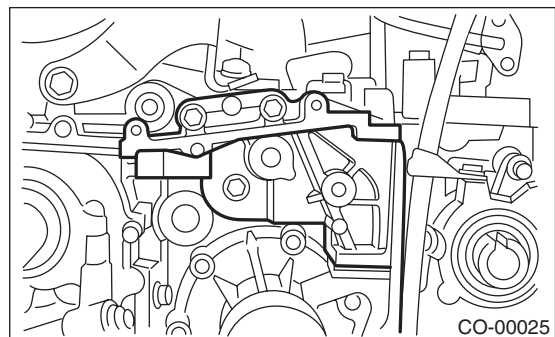

Water Pump

COOLING

4) Install the belt cover No. 2 (LH).

Tightening torque:

5 N·m (0.5 kgf·m, 3.6 ft·lb)

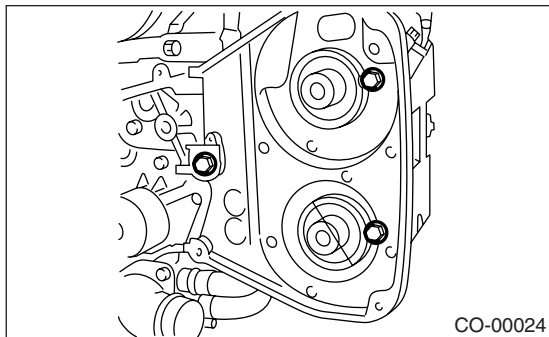

5) Install the camshaft sprockets (LH) by using ST. <Ref. to ME(H4DOTC)-54, INSTALLATION, Camshaft Sprocket.>

6) Install the camshaft position sensor. <Ref. to FU(H4DOTC)-29, INSTALLATION, Camshaft Position Sensor.>

7) Install the belt idler No. 2 (C).

8) Install the belt idler (B).

9) Install the automatic belt tension adjuster (A) which has tension rod held by pin. <Ref. to ME(H4DOTC)-48, AUTOMATIC BELT TENSION ADJUSTER ASSEMBLY AND BELT IDLER, INSTALLATION, Timing Belt Assembly.>

Tightening torque:

39 N·m (4.0 kgf·m, 28.9 ft·lb)

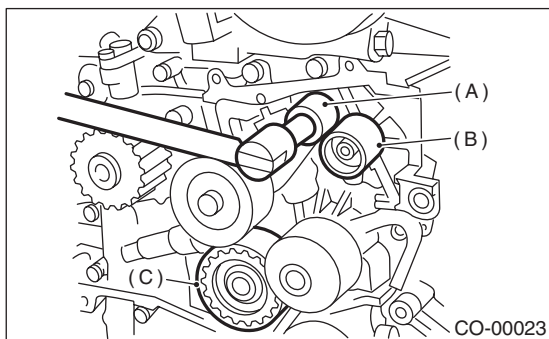

10) Install the timing belt. <Ref. to ME(H4DOTC)-49, TIMING BELT, INSTALLATION, Timing Belt Assembly.>

11) Install the V-belts. <Ref. to ME(H4DOTC)-42, INSTALLATION, V-belt.>

12) Install the radiator. <Ref. to CO(H4DOTC)-23, INSTALLATION, Radiator.>

C: INSPECTION

1) Check the water pump bearing for smooth rotation.

2) Check the water pump pulley for abnormalities.

3) Using a dial gauge, measure the impeller runout in thrust direction while rotating the pulley.

“Thrust” runout limit:

0.5 mm (0.020 in)

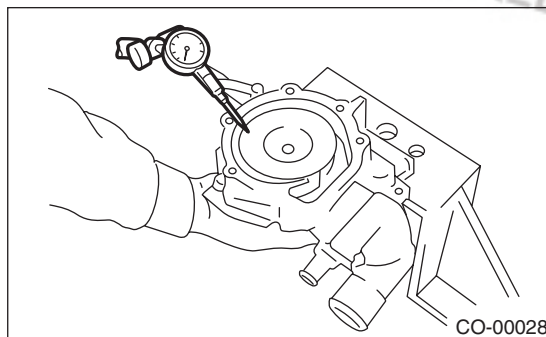

4) Check the clearance between impeller and pump case.

Clearance between impeller and pump case:

Standard

0.5 — 0.7 mm (0.020 — 0.028 in)

Limit

1.0 mm (0.039 in)

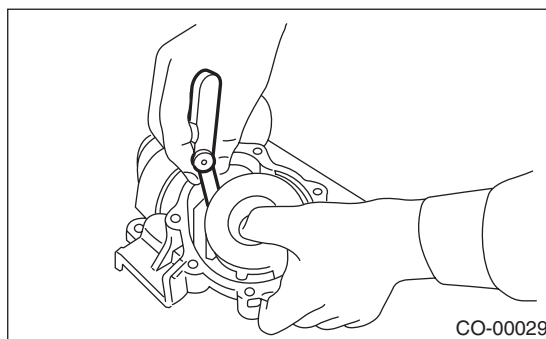

5) After water pump installation, check the pulley shaft for engine coolant leaks. If leaks are noted, replace the water pump assembly.

6. Thermostat

A: REMOVAL

- 1) Set the vehicle on a lift.
- 2) Lift-up the vehicle.
- 3) Remove the under cover.
- 4) Drain the engine coolant completely. <Ref. to CO(H4DOTC)-17, DRAINING OF ENGINE COOLANT, REPLACEMENT, Engine Coolant.>

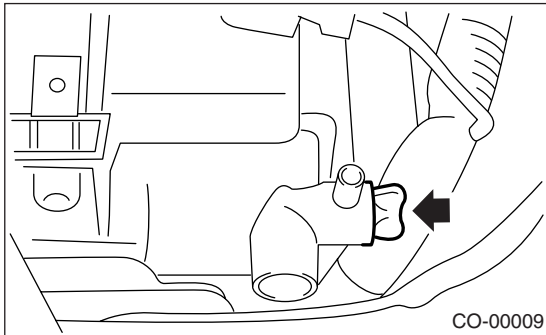

- 5) Disconnect the radiator outlet hose.

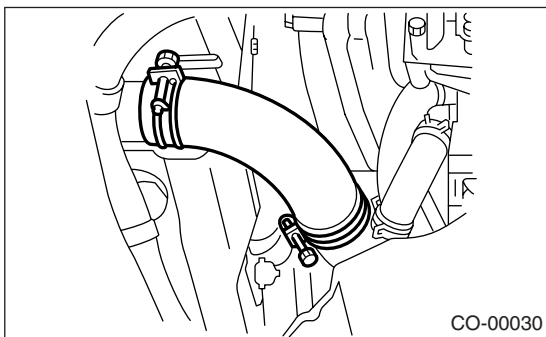

- 6) Remove the thermostat cover and gasket, and then pull out the thermostat.

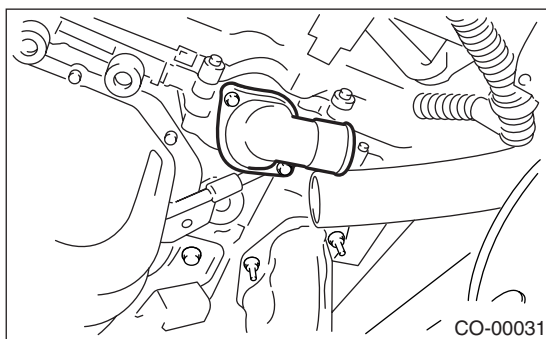

B: INSTALLATION

- 1) Install the thermostat in water pump, and then install the thermostat cover together with a gasket.

NOTE:

- When reinstalling the thermostat, use a new gasket.
- The thermostat must be installed with the jiggle pin (A) facing to front side.

Tightening torque:

6.5 N·m (0.65 kgf·m, 4.7 ft·lb)

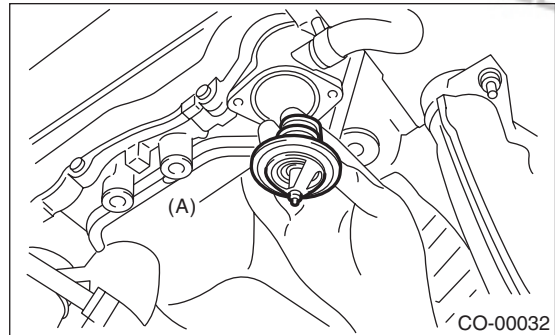

- 2) Fill engine coolant. <Ref. to CO(H4DOTC)-17, FILLING OF ENGINE COOLANT, REPLACEMENT, Engine Coolant.>

C: INSPECTION

Replace the thermostat if the valve does not close completely at an ambient temperature or if the following test shows unsatisfactory results.

Immerse the thermostat and thermometer in water. Raise water temperature gradually, and measure the temperature and valve lift when the valve begins to open and when the valve is fully opened. During the test, agitate the water for even temperature distribution. The measurement should be to the specification.

Starts to open:

76 — 80 °C (169 — 176°F)

Fully opens:

91 °C (196°F)

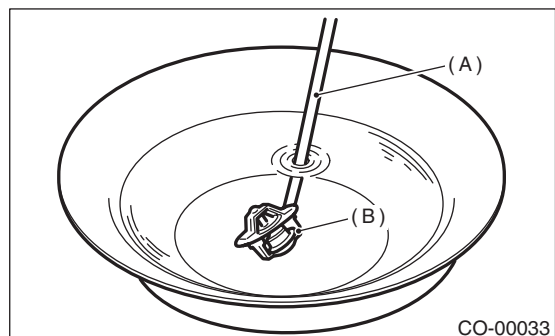

(A) Thermometer

(B) Thermostat

7. Radiator

A: REMOVAL

WARNING:

The radiator is pressurized. Wait until the engine cools down before working on the radiator.

- 1) Set the vehicle on a lift.
- 2) Disconnect the ground cable from battery.

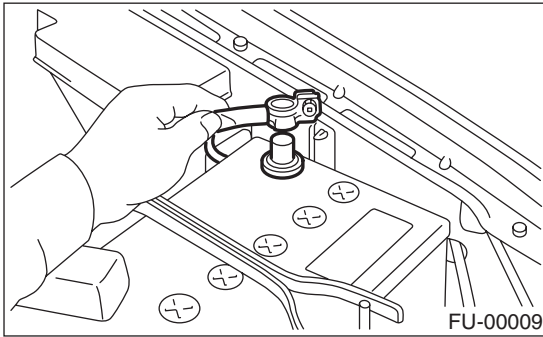

- 3) Lift-up the vehicle.
- 4) Remove the under cover.
- 5) Drain the engine coolant completely. <Ref. to CO(H4DOTC)-17, DRAINING OF ENGINE COOLANT, REPLACEMENT, Engine Coolant.>
- 6) Disconnect the connectors of radiator main fan motor (A) and sub fan motor (B).

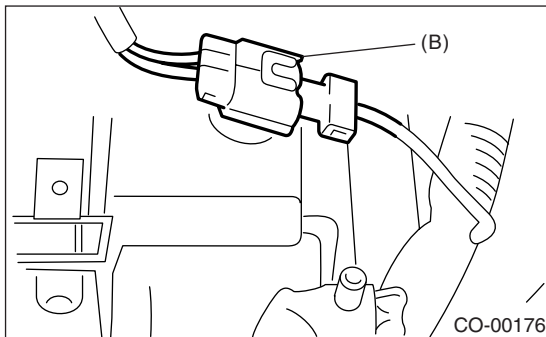
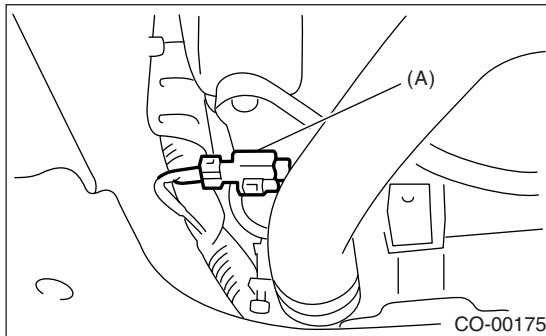

- 7) Disconnect the ATF cooler hose from ATF pipe. (AT model) Plug the openings in the hose and radiator with caps in order to prevent ATF from leaking.

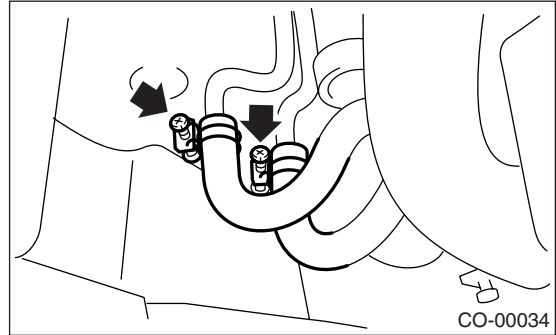

- 8) Disconnect the radiator outlet hose from thermostat cover.

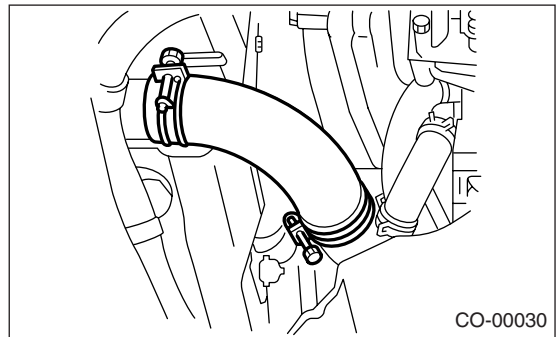

- 9) Lower the vehicle.
- 10) Remove the air intake duct.

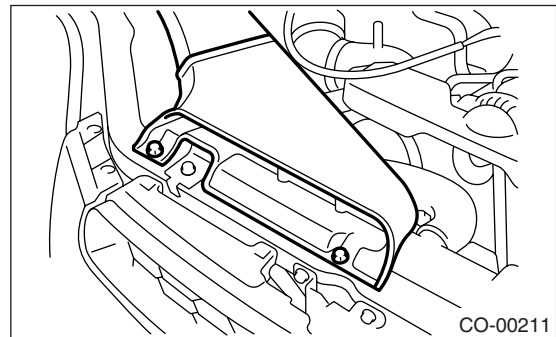

- 11) Remove the V-belt covers.

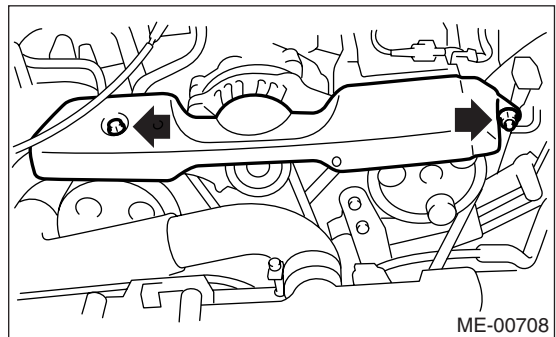

- 12) Disconnect the overflow hose.
- 13) Remove the reservoir tank. <Ref. to CO(H4DOTC)-31, REMOVAL, Reservoir Tank.>

- 14) Disconnect the radiator inlet hose (A) and water tank hose (B) from radiator.

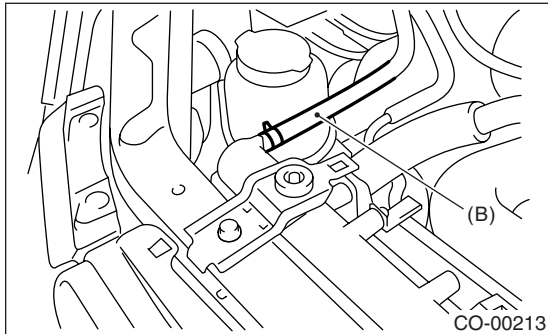
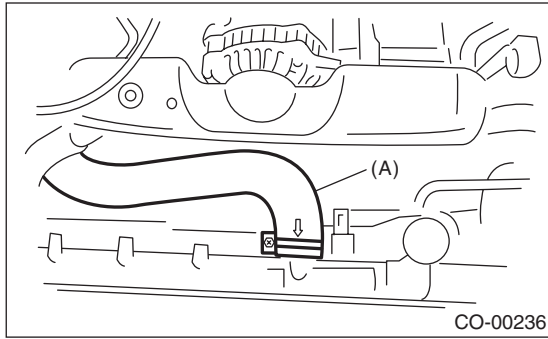

- 15) Remove the radiator upper brackets.

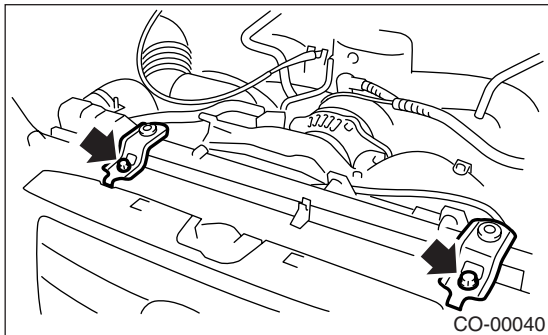

- 16) While lifting the radiator up, slide it to the left.
17) Lift-up the radiator, and then remove it from vehicle.

B: INSTALLATION

- 1) Attach the radiator mounting cushions to the holes on vehicle.

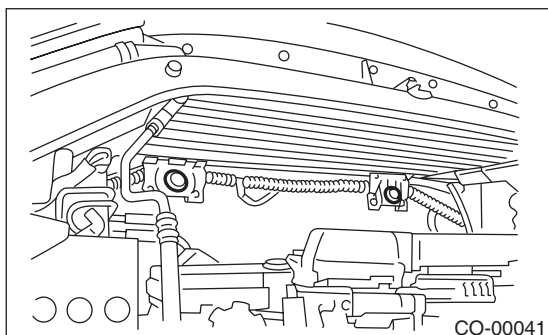

- 2) Install the radiator to vehicle.

- NOTE:
Fit the pins on lower side of radiator into the cushions on body side.
3) Install the radiator brackets, and then tighten the bolts.

Tightening torque:
18 N·m (1.8 kgf-m, 13.0 ft-lb)

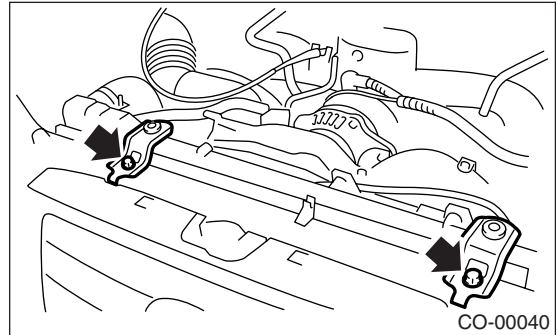

- 4) Connect the radiator inlet hose (A) and water tank hose (B).

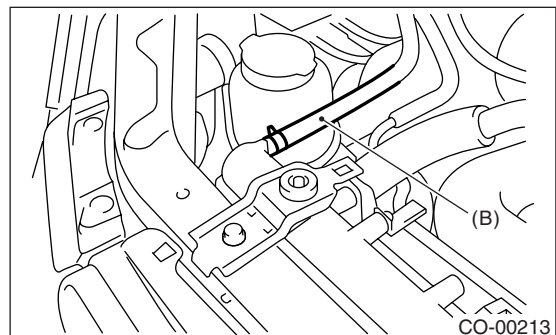
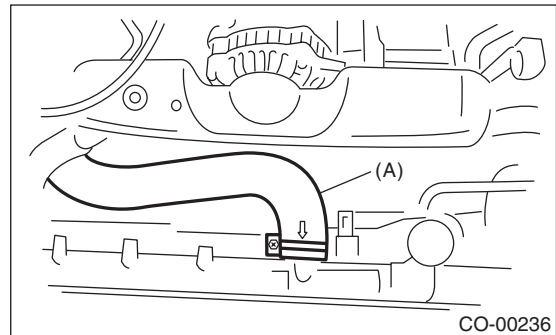

- 5) Install the reservoir tank. <Ref. to CO(H4DOTC)-31, INSTALLATION, Reservoir Tank.>

- 6) Connect the overflow hose.

Radiator

COOLING

7) Install the V-belt cover.

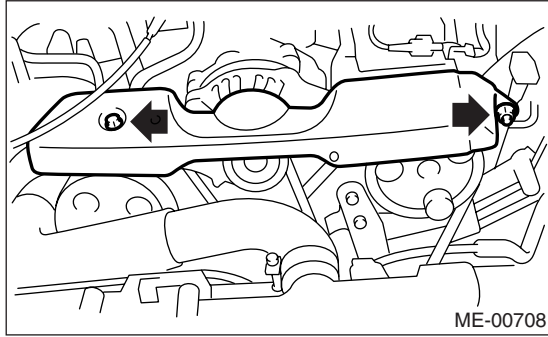

8) Install the air intake duct.

<Ref. to IN(H4DOTC)-8, INSTALLATION, Air Intake Duct.>

9) Lift-up the vehicle.

10) Connect the ATF cooler hoses. (AT model).

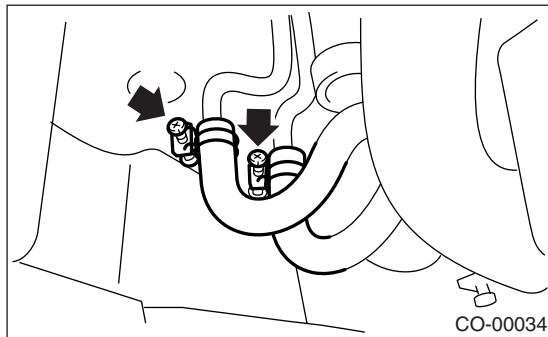

11) Connect the radiator outlet hose.

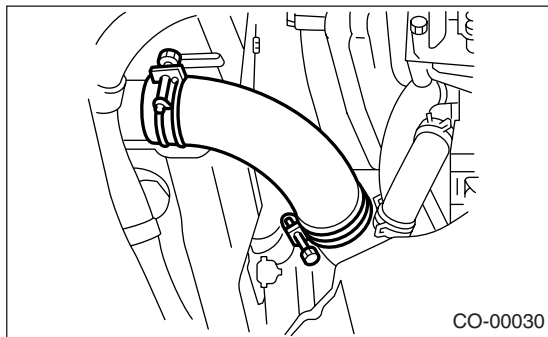

12) Connect the connectors to radiator main fan motor (A) and sub fan motor (B).

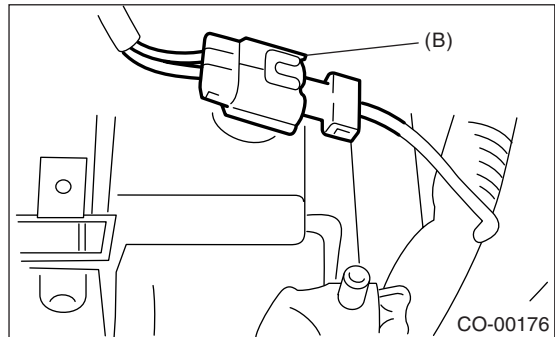
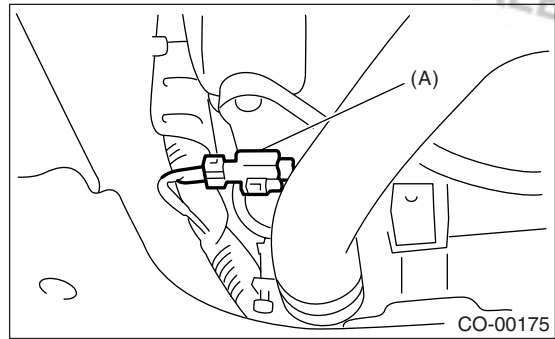

13) Install the under cover.

14) Lower the vehicle.

15) Connect the battery ground cable to battery.

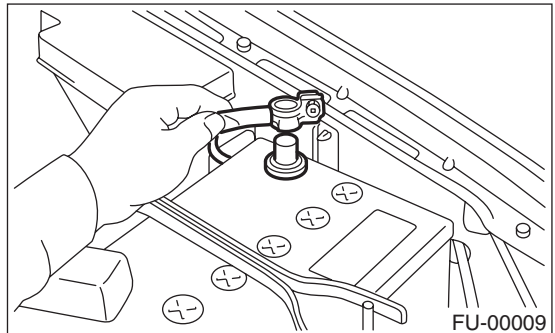

16) Fill engine coolant. <Ref. to CO(H4DOTC)-17, FILLING OF ENGINE COOLANT, REPLACEMENT, Engine Coolant.>

17) Check the ATF level. <Ref. to 4AT-30, INSPECTION, Automatic Transmission Fluid.>

C: INSPECTION

1) Remove the coolant filler tank cap, top off coolant filler tank, and then attach the tester to coolant filler tank in place of cap.

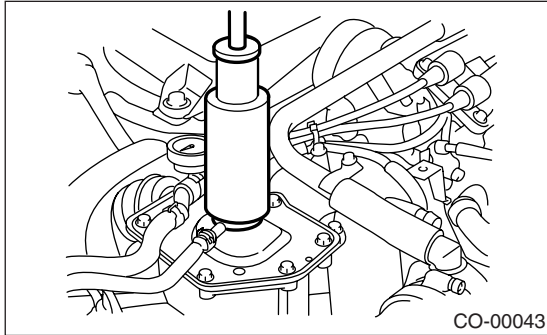

2) Apply a pressure of 122 kPa (1.2 kg/cm², 18 psi) to the radiator to check if:

- (1) Engine coolant leaks at/around radiator.
- (2) Engine coolant leaks at/around hoses or connections.

CAUTION:

- Inspection must be carried out at the side of coolant filler tank, not at the side of radiator.
- Engine should be turned off.
- Wipe engine coolant from check points in advance.
- Be careful to prevent engine coolant from spurting out when removing the tester.
- Be careful also not to deform the filler neck of coolant filler tank when installing or removing tester.

8. Radiator Cap

A: INSPECTION

1) Attach the radiator cap to tester.

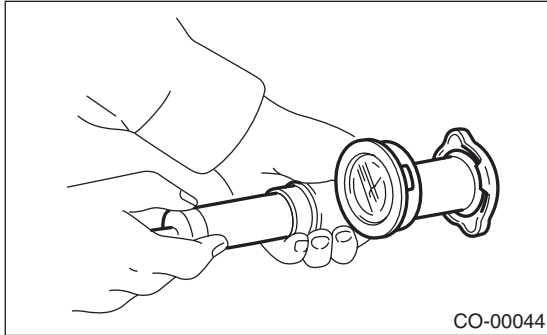

2) Increase the pressure until tester gauge pointer stops. Radiator cap is functioning properly if it holds the service limit pressure for 5 to 6 seconds.

Coolant filler tank side

Standard pressure:

93 — 123 kPa (0.95 — 1.25 kg/cm², 14 — 18 psi)

Service limit pressure:

83 kPa (0.85 kg/cm², 12 psi)

Radiator side

Standard pressure:

122 — 152 kPa (1.24 — 1.55 kg/cm², 18 — 22 psi)

Service limit pressure:

112 kPa (1.14 kg/cm², 16 psi)

CAUTION:

- Be sure to remove foreign matter and rust from the cap in advance otherwise, results of pressure test will be incorrect.
- Do not mix up the coolant filler tank side cap with radiator side cap.

9. Radiator Main Fan and Fan Motor

A: REMOVAL

- 1) Disconnect the ground cable from battery.

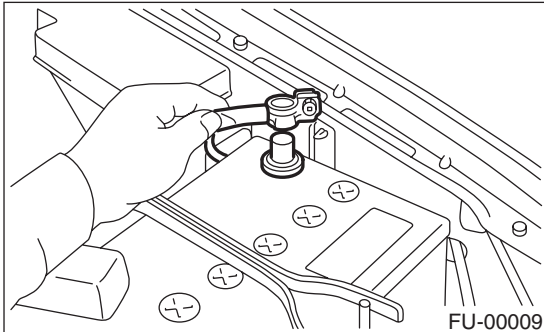

- 2) Lift-up the vehicle.
- 3) Remove the under cover.
- 4) Disconnect the connector of main fan motor (A).

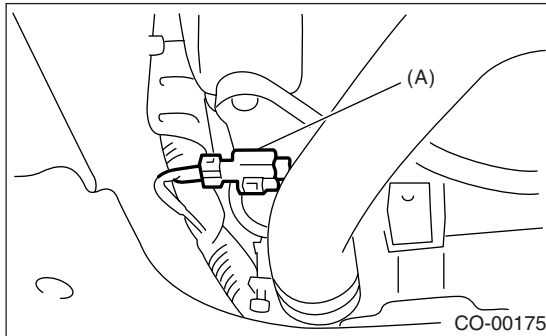

- 5) Lower the vehicle.
- 6) Remove the air intake duct.

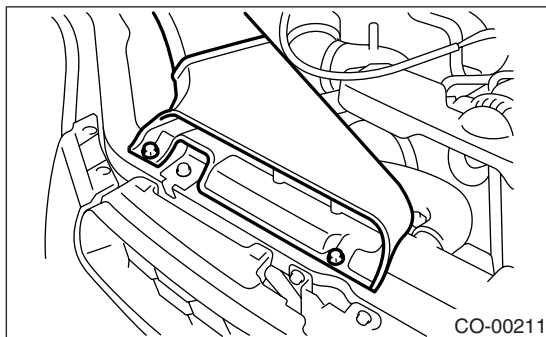

- 7) Disconnect the overflow hose.
- 8) Remove the overflow pipe.
- 9) Remove the reservoir tank. <Ref. to CO(H4DOTC)-31, REMOVAL, Reservoir Tank.>

- 10) Remove the radiator main fan motor assembly.

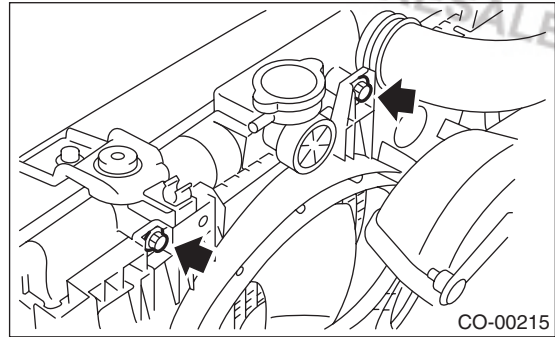

B: INSTALLATION

Install in the reverse order of removal.

NOTE:

When the main fan motor assembly cannot be installed as is, loosen the sub fan motor assembly securing bolts to install it.

Tightening torque:

4.9 N·m (0.50 kgf-m, 3.6 ft-lb)

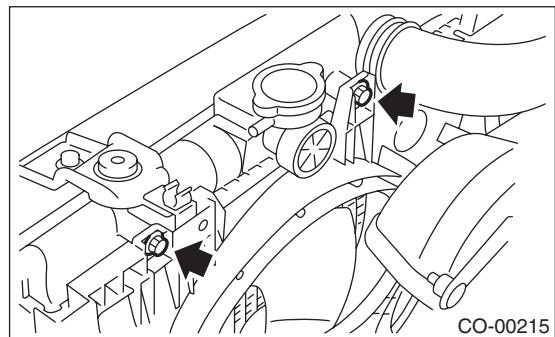

C: DISASSEMBLY

- 1) Remove the nut which holds the fan itself onto fan motor and shroud assembly.

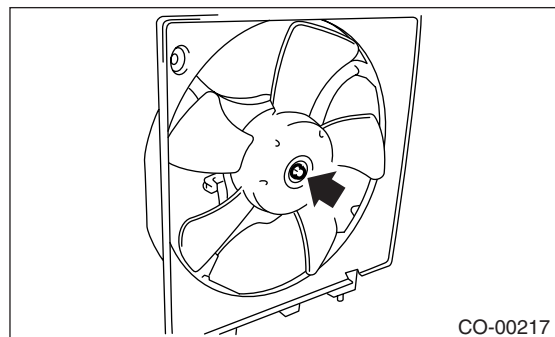

Radiator Main Fan and Fan Motor

COOLING

2) Remove the bolts which install the fan motor onto shroud.

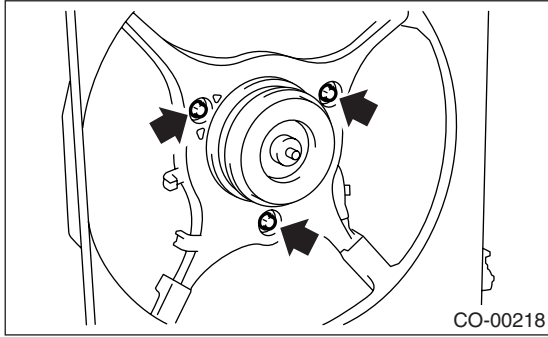

D: ASSEMBLY

Assemble in the reverse order of disassembly.

Tightening torque:

4.4 N·m (0.45 kgf-m, 3.3 ft-lb)

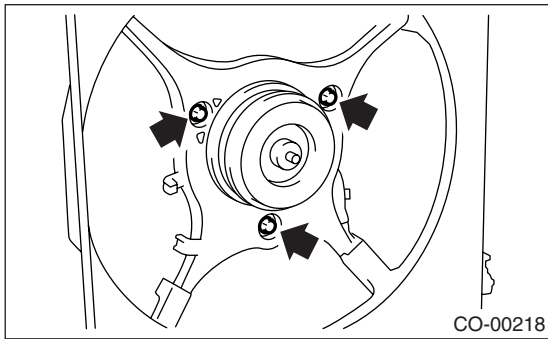

Tightening torque:

3.4 N·m (0.35 kgf-m, 2.5 ft-lb)

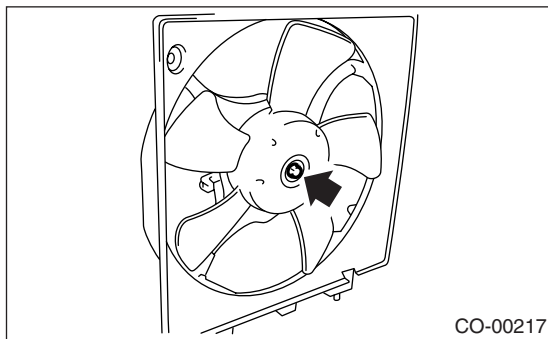

10. Radiator Sub Fan and Fan Motor

A: REMOVAL

- 1) Disconnect the ground cable from battery.

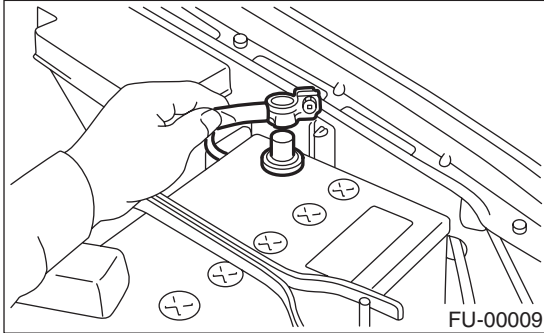

- 2) Lift-up the vehicle.
- 3) Remove the under cover.
- 4) Disconnect the connector of sub fan motor (B).

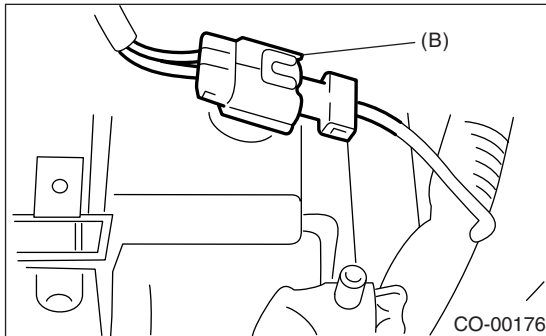

- 5) Lower the vehicle.
- 6) Remove the air intake duct.

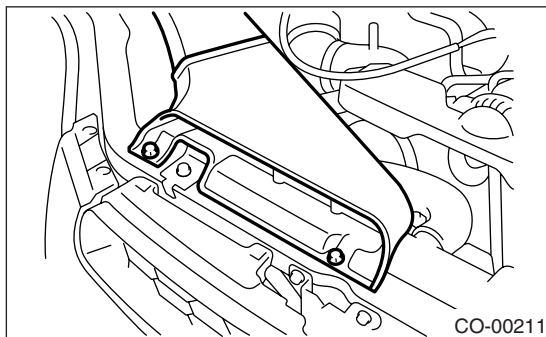

- 7) Remove the bolts which hold the sub fan shroud to radiator.
- 8) Remove the overflow pipe.

- 9) Remove the radiator sub fan shroud through the under side of vehicle.

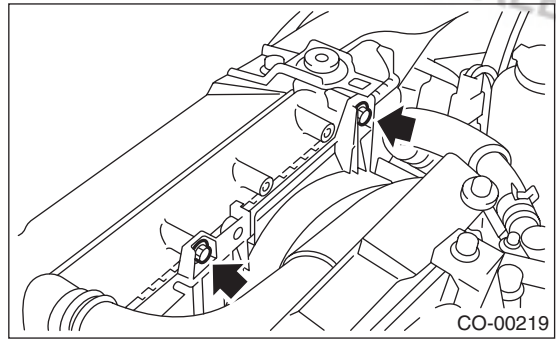

B: INSTALLATION

Install in the reverse order of removal.

Tightening torque:

4.9 N·m (0.50 kgf·m, 3.6 ft·lb)

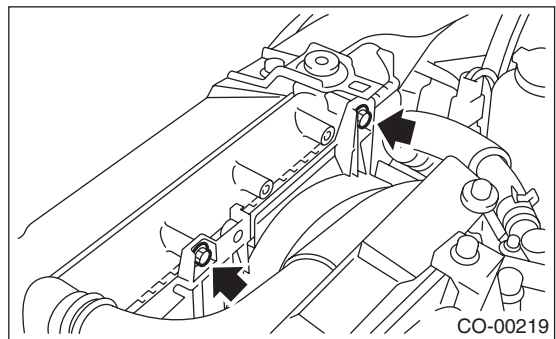

C: DISASSEMBLY

- 1) Remove the clip which holds the motor harness onto shroud.

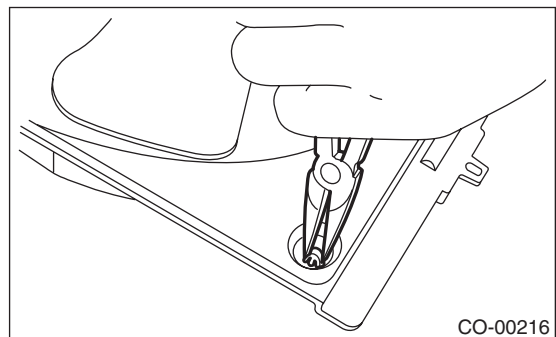

- 2) Remove the nut which holds the fan itself onto fan motor and shroud assembly.

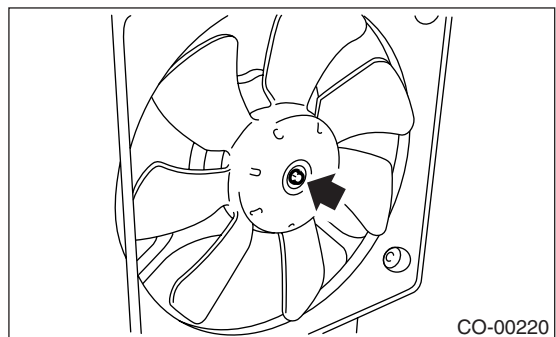

Radiator Sub Fan and Fan Motor

COOLING

3) Remove the bolts which install the fan motor onto shroud.

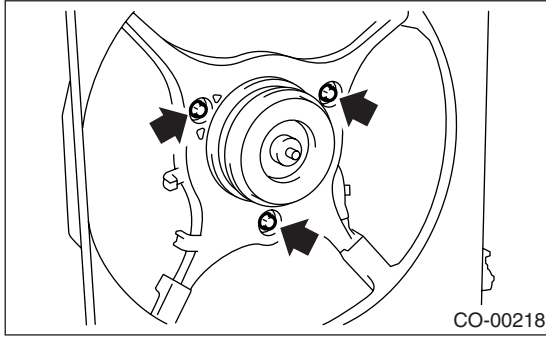

D: ASSEMBLY

Assemble in the reverse order of disassembly.

Tightening torque:

4.4 N·m (0.45 kgf-m, 3.3 ft-lb)

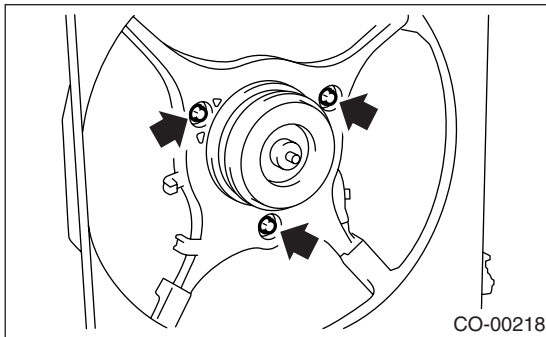

Tightening torque:

3.4 N·m (0.35 kgf-m, 2.5 ft-lb)

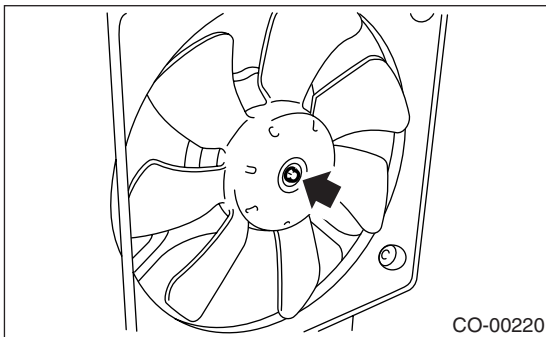

11. Reservoir Tank

A: REMOVAL

- 1) Disconnect the overflow hose from the radiator filler neck position.
- 2) Pull out the reservoir tank to direction of arrow while pushing the pawl (A).

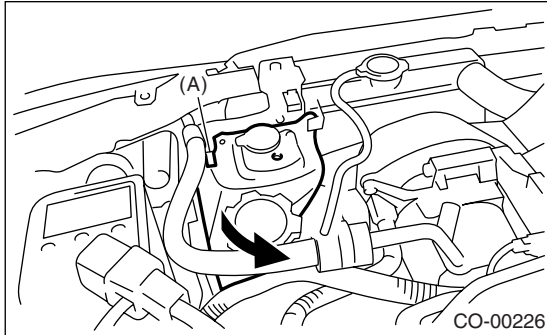

B: INSTALLATION

Install in the reverse order of removal.

NOTE:

Refer to COMPONENT for tightening torque. <Ref. to CO(H4DOTC)-3, COMPONENT, General Description.>

C: INSPECTION

Make sure the engine coolant level is between full and low.

12. Coolant Filler Tank

A: REMOVAL

WARNING:

The radiator is pressurized. Wait until the engine cools down before working on the radiator.

- 1) Drain the coolant about 3.0 ℓ (3.2 US qt, 2.6 Imp qt). <Ref. to CO(H4DOTC)-17, DRAINING OF ENGINE COOLANT, REPLACEMENT, Engine Coolant.>
- 2) Remove the air cleaner upper cover and air intake boot. <Ref. to IN(H4DOTC)-7, REMOVAL, Air Cleaner.>
- 3) Remove the air cleaner element.
- 4) Disconnect the engine coolant hoses from coolant filler tank.

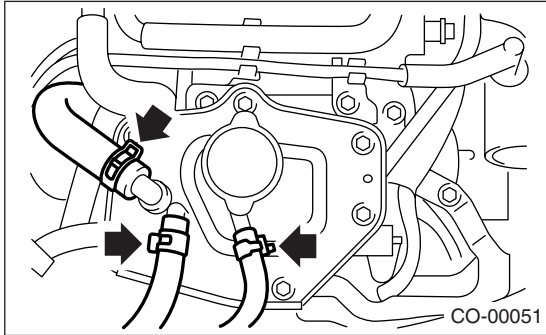

- 5) Remove the bolts and nut which install the coolant filler tank.
- 6) Disconnect the engine coolant hose which connects the under side of coolant filler tank.
- 7) Remove the coolant filler tank.

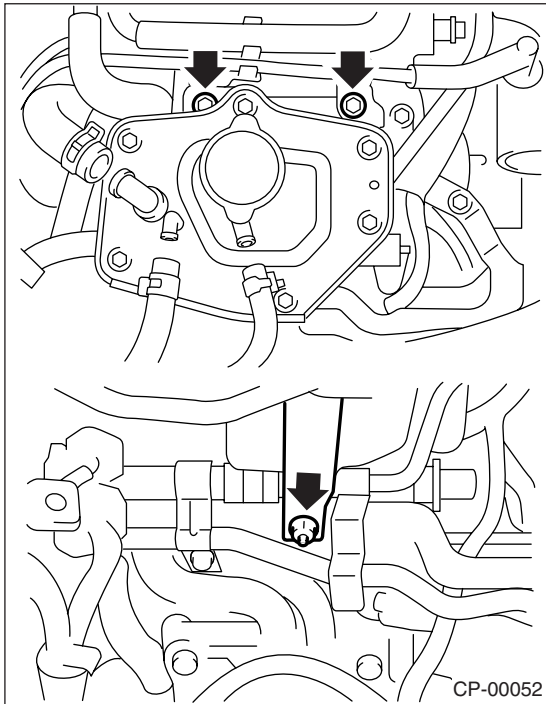

B: INSTALLATION

- 1) Install in the reverse order of removal.

Tightening torque:

T1: 16 N·m (1.6 kgf-m, 11.8 ft-lb)

T2: 13 N·m (1.3 kgf-m, 9.6 ft-lb)

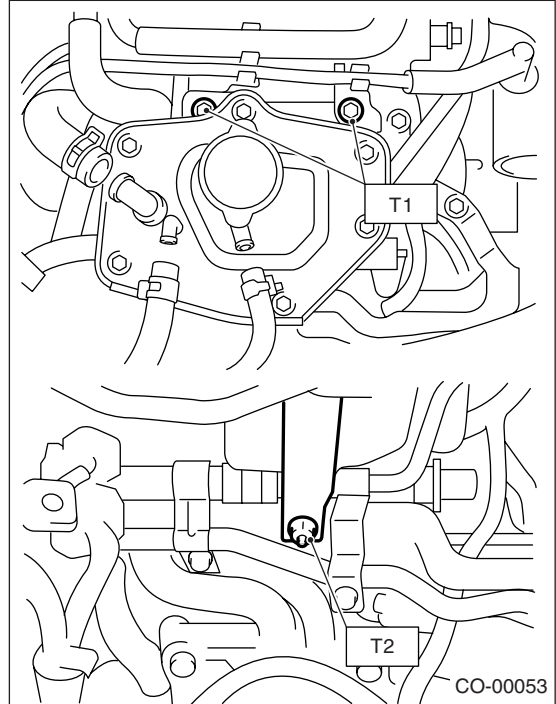

- 2) Fill engine coolant. <Ref. to CO(H4DOTC)-17, FILLING OF ENGINE COOLANT, REPLACEMENT, Engine Coolant.>

13.Engine Cooling System Trouble in General

A: INSPECTION

Trouble	Possible cause	Corrective action
Over-heating	a. Insufficient engine coolant	Replenish the engine coolant, inspect for leakage, and repair.
	b. Loose timing belt	Repair or replace the timing belt tensioner.
	c. Oil on drive belt	Replace.
	d. Malfunction of thermostat	Replace.
	e. Malfunction of water pump	Replace.
	f. Clogged engine coolant passage	Clean.
	g. Improper ignition timing	Inspect and repair the ignition control system. <Ref. to EN(H4DOTC)(diag)-2, PROCEDURE, Basic Diagnostic Procedure.>
	h. Clogged or leaking radiator	Clean or repair, or replace.
	i. Improper engine oil in engine coolant	Replace the engine coolant.
	j. Air/fuel mixture ratio too lean	Inspect and repair the fuel injection system. <Ref. to EN(H4DOTC)(diag)-2, PROCEDURE, Basic Diagnostic Procedure.>
	k. Excessive back pressure in exhaust system	Clean or replace.
	l. Insufficient clearance between piston and cylinder	Adjust or replace.
	m. Slipping clutch	Repair or replace.
	n. Dragging brake	Adjust.
	o. Defective thermostat	Replace.
p. Malfunction of radiator fan	Inspect the radiator fan relay, engine coolant temperature sensor or radiator motor and replace there.	
Over-cooling	a. Atmospheric temperature extremely low	Partly cover the radiator front area.
	b. Defective thermostat	Replace.
Engine coolant leaks	a. Loosened or damaged connecting units on hoses	Repair or replace.
	b. Leakage from water pump	Replace.
	c. Leakage from water pipe	Repair or replace.
	d. Leakage around cylinder head gasket	Retighten the cylinder head bolts or replace gasket.
	e. Damaged or cracked cylinder head and crankcase	Repair or replace.
	f. Damaged or cracked thermostat case	Repair or replace.
	g. Leakage from radiator	Repair or replace.
Noise	a. Defective drive belt	Replace.
	b. Defective radiator fan	Replace.
	c. Defective water pump bearing	Replace the water pump.
	d. Defective water pump mechanical seal	Replace the water pump.

Brought to you by Eris Studios
NOT FOR RESALE