

Brought to you by Eris Studios  
NOT FOR RESALE

## **GENERAL DESCRIPTION**

# List of Diagnostic Trouble Code (DTC)

## GENERAL DESCRIPTION

### 1. List of Diagnostic Trouble Code (DTC)

#### A: LIST

DTC	Description	Index
P0030	HO2S Heater Control Circuit (Bank 1 Sensor 1)	<Ref. to GD(H4DOTC)-9, DTC P0030 HO2S HEATER CONTROL CIRCUIT (BANK 1 SENSOR 1), Diagnostic Trouble Code (DTC) Detecting Criteria.>
P0031	HO2S Heater Control Circuit Low (Bank 1 Sensor 1)	<Ref. to GD(H4DOTC)-11, DTC P0031 HO2S HEATER CONTROL CIRCUIT LOW (BANK 1 SENSOR 1), Diagnostic Trouble Code (DTC) Detecting Criteria.>
P0032	HO2S Heater Control Circuit High (Bank 1 Sensor 1)	<Ref. to GD(H4DOTC)-13, DTC P0032 HO2S HEATER CONTROL CIRCUIT HIGH (BANK 1 SENSOR 1), Diagnostic Trouble Code (DTC) Detecting Criteria.>
P0037	HO2S Heater Control Circuit Low (Bank 1 Sensor 2)	<Ref. to GD(H4DOTC)-15, DTC P0037 HO2S HEATER CONTROL CIRCUIT LOW (BANK 1 SENSOR 2), Diagnostic Trouble Code (DTC) Detecting Criteria.>
P0038	HO2S Heater Control Circuit High (Bank 1 Sensor 2)	<Ref. to GD(H4DOTC)-17, DTC P0038 HO2S HEATER CONTROL CIRCUIT HIGH (BANK 1 SENSOR 2), Diagnostic Trouble Code (DTC) Detecting Criteria.>
P0068	Manifold Pressure Sensor Range/Performance	<Ref. to GD(H4DOTC)-19, DTC P0068 MANIFOLD PRESSURE SENSOR RANGE/PERFORMANCE, Diagnostic Trouble Code (DTC) Detecting Criteria.>
P0101	Mass or Volume Air Flow Circuit Range/Performance	<Ref. to GD(H4DOTC)-21, DTC P0101 MASS OR VOLUME AIR FLOW CIRCUIT RANGE/PERFORMANCE, Diagnostic Trouble Code (DTC) Detecting Criteria.>
P0102	Mass or Volume Air Flow Circuit Low Input	<Ref. to GD(H4DOTC)-23, DTC P0102 MASS OR VOLUME AIR FLOW CIRCUIT LOW INPUT, Diagnostic Trouble Code (DTC) Detecting Criteria.>
P0103	Mass or Volume Air Flow Circuit High Input	<Ref. to GD(H4DOTC)-25, DTC P0103 MASS OR VOLUME AIR FLOW CIRCUIT HIGH INPUT, Diagnostic Trouble Code (DTC) Detecting Criteria.>
P0107	Manifold Absolute Pressure/Barometric Pressure Circuit Low Input	<Ref. to GD(H4DOTC)-27, DTC P0107 MANIFOLD ABSOLUTE PRESSURE/BAROMETRIC PRESSURE CIRCUIT LOW INPUT, Diagnostic Trouble Code (DTC) Detecting Criteria.>
P0108	Manifold Absolute Pressure/Barometric Pressure Circuit High Input	<Ref. to GD(H4DOTC)-29, DTC P0108 MANIFOLD ABSOLUTE PRESSURE/BAROMETRIC PRESSURE CIRCUIT HIGH INPUT, Diagnostic Trouble Code (DTC) Detecting Criteria.>
P0111	Intake Air Temperature Circuit Range/Performance	<Ref. to GD(H4DOTC)-31, DTC P0111 INTAKE AIR TEMPERATURE CIRCUIT RANGE/PERFORMANCE, Diagnostic Trouble Code (DTC) Detecting Criteria.>
P0112	Intake Air Temperature Circuit Low Input	<Ref. to GD(H4DOTC)-33, DTC P0112 INTAKE AIR TEMPERATURE CIRCUIT LOW INPUT, Diagnostic Trouble Code (DTC) Detecting Criteria.>
P0113	Intake Air Temperature Circuit High Input	<Ref. to GD(H4DOTC)-35, DTC P0113 INTAKE AIR TEMPERATURE CIRCUIT HIGH INPUT, Diagnostic Trouble Code (DTC) Detecting Criteria.>
P0117	Engine Coolant Temperature Circuit Low Input	<Ref. to GD(H4DOTC)-37, DTC P0117 ENGINE COOLANT TEMPERATURE CIRCUIT LOW INPUT, Diagnostic Trouble Code (DTC) Detecting Criteria.>
P0118	Engine Coolant Temperature Circuit High Input	<Ref. to GD(H4DOTC)-39, DTC P0118 ENGINE COOLANT TEMPERATURE CIRCUIT HIGH INPUT, Diagnostic Trouble Code (DTC) Detecting Criteria.>
P0121	Throttle/Pedal Position Sensor/Switch "A" Circuit Range/Performance	<Ref. to GD(H4DOTC)-41, DTC P0121 THROTTLE/PEDAL POSITION SENSOR/SWITCH "A" CIRCUIT RANGE/PERFORMANCE, Diagnostic Trouble Code (DTC) Detecting Criteria.>
P0122	Throttle/Pedal Position Sensor/Switch "A" Circuit Low Input	<Ref. to GD(H4DOTC)-44, DTC P0122 THROTTLE/PEDAL POSITION SENSOR/SWITCH "A" CIRCUIT LOW INPUT, Diagnostic Trouble Code (DTC) Detecting Criteria.>
P0123	Throttle/Pedal Position Sensor/Switch "A" Circuit High Input	<Ref. to GD(H4DOTC)-46, DTC P0123 THROTTLE/PEDAL POSITION SENSOR/SWITCH "A" CIRCUIT HIGH INPUT, Diagnostic Trouble Code (DTC) Detecting Criteria.>

# List of Diagnostic Trouble Code (DTC)

GENERAL DESCRIPTION

DTC	Description	Index
P0125	Insufficient Coolant Temperature For Closed Loop Fuel Control	<Ref. to GD(H4DOTC)-48, DTC P0125 INSUFFICIENT COOLANT TEMPERATURE FOR CLOSED LOOP FUEL CONTROL, Diagnostic Trouble Code (DTC) Detecting Criteria.>
P0128	Coolant Thermostat (Coolant Temperature Below Thermostat Regulating Temperature)	<Ref. to GD(H4DOTC)-50, DTC P0128 COOLANT THERMOSTAT (COOLANT TEMPERATURE BELOW THERMOSTAT REGULATING TEMPERATURE), Diagnostic Trouble Code (DTC) Detecting Criteria.>
P0129	Barometric Pressure Too Low	<Ref. to GD(H4DOTC)-52, DTC P0129 BAROMETRIC PRESSURE TOO LOW, Diagnostic Trouble Code (DTC) Detecting Criteria.>
P0130	O <sub>2</sub> Sensor Circuit (Bank 1 Sensor 1)	<Ref. to GD(H4DOTC)-53, DTC P0130 O <sub>2</sub> SENSOR CIRCUIT (BANK 1 SENSOR 1), Diagnostic Trouble Code (DTC) Detecting Criteria.>
P0133	O <sub>2</sub> Sensor Circuit Slow Response (Bank 1 Sensor 1)	<Ref. to GD(H4DOTC)-55, DTC P0133 O <sub>2</sub> SENSOR CIRCUIT SLOW RESPONSE (BANK 1 SENSOR 1), Diagnostic Trouble Code (DTC) Detecting Criteria.>
P0134	O <sub>2</sub> Sensor Circuit No Activity Detected (Bank 1 Sensor 1)	<Ref. to GD(H4DOTC)-58, DTC P0134 O <sub>2</sub> SENSOR CIRCUIT NO ACTIVITY DETECTED (BANK 1 SENSOR 1), Diagnostic Trouble Code (DTC) Detecting Criteria.>
P0137	O <sub>2</sub> Sensor Circuit Low Voltage (Bank 1 Sensor 2)	<Ref. to GD(H4DOTC)-60, DTC P0137 O <sub>2</sub> SENSOR CIRCUIT LOW VOLTAGE (BANK 1 SENSOR 2), Diagnostic Trouble Code (DTC) Detecting Criteria.>
P0138	O <sub>2</sub> Sensor Circuit High Voltage (Bank 1 Sensor 2)	<Ref. to GD(H4DOTC)-62, DTC P0138 O <sub>2</sub> SENSOR CIRCUIT HIGH VOLTAGE (BANK 1 SENSOR 2), Diagnostic Trouble Code (DTC) Detecting Criteria.>
P0139	O <sub>2</sub> Sensor Circuit Slow Response (Bank 1 Sensor 2)	<Ref. to GD(H4DOTC)-64, DTC P0139 O <sub>2</sub> SENSOR CIRCUIT SLOW RESPONSE (BANK 1 SENSOR 2), Diagnostic Trouble Code (DTC) Detecting Criteria.>
P0171	System Too Lean (Bank 1)	<Ref. to GD(H4DOTC)-67, DTC P0171 SYSTEM TOO LEAN (BANK 1), Diagnostic Trouble Code (DTC) Detecting Criteria.>
P0172	System Too Rich (Bank 1)	<Ref. to GD(H4DOTC)-70, DTC P0172 SYSTEM TOO RICH (BANK 1), Diagnostic Trouble Code (DTC) Detecting Criteria.>
P0181	Fuel Temperature Sensor "A" Circuit Range/Performance	<Ref. to GD(H4DOTC)-73, DTC P0181 FUEL TEMPERATURE SENSOR "A" CIRCUIT RANGE/PERFORMANCE, Diagnostic Trouble Code (DTC) Detecting Criteria.>
P0182	Fuel Temperature Sensor "A" Circuit Low Input	<Ref. to GD(H4DOTC)-76, DTC P0182 FUEL TEMPERATURE SENSOR "A" CIRCUIT LOW INPUT, Diagnostic Trouble Code (DTC) Detecting Criteria.>
P0183	Fuel Temperature Sensor "A" Circuit High Input	<Ref. to GD(H4DOTC)-78, DTC P0183 FUEL TEMPERATURE SENSOR "A" CIRCUIT HIGH INPUT, Diagnostic Trouble Code (DTC) Detecting Criteria.>
P0230	Fuel Pump Primary Circuit	<Ref. to GD(H4DOTC)-81, ECM OPERATING AT DTC SETTING, DTC P0230 FUEL PUMP PRIMARY CIRCUIT, Diagnostic Trouble Code (DTC) Detecting Criteria.>
P0244	Turbo/Super Charger Wastegate Solenoid "A" Range/Performance	<Ref. to GD(H4DOTC)-82, DTC P0244 TURBO/SUPER CHARGER WASTEGATE SOLENOID "A" RANGE/PERFORMANCE, Diagnostic Trouble Code (DTC) Detecting Criteria.>
P0245	Turbo/Super Charger Wastegate Solenoid "A" Low	<Ref. to GD(H4DOTC)-84, DTC P0245 TURBO/SUPER CHARGER WASTEGATE SOLENOID "A" LOW, Diagnostic Trouble Code (DTC) Detecting Criteria.>
P0246	Turbo/Super Charger Wastegate Solenoid "A" High	<Ref. to GD(H4DOTC)-86, DTC P0246 TURBO/SUPER CHARGER WASTEGATE SOLENOID "A" HIGH, Diagnostic Trouble Code (DTC) Detecting Criteria.>
P0301	Cylinder 1 Misfire Detected	<Ref. to GD(H4DOTC)-88, DTC P0301 CYLINDER 1 MISFIRE DETECTED, Diagnostic Trouble Code (DTC) Detecting Criteria.>
P0302	Cylinder 2 Misfire Detected	<Ref. to GD(H4DOTC)-94, DTC P0302 CYLINDER 2 MISFIRE DETECTED, Diagnostic Trouble Code (DTC) Detecting Criteria.>
P0303	Cylinder 3 Misfire Detected	<Ref. to GD(H4DOTC)-94, DTC P0303 CYLINDER 3 MISFIRE DETECTED, Diagnostic Trouble Code (DTC) Detecting Criteria.>

## List of Diagnostic Trouble Code (DTC)

### GENERAL DESCRIPTION

DTC	Description	Index
P0304	Cylinder 4 Misfire Detected	<Ref. to GD(H4DOTC)-94, DTC P0304 CYLINDER 4 MISFIRE DETECTED, Diagnostic Trouble Code (DTC) Detecting Criteria.>
P0327	Knock Sensor 1 Circuit Low Input (Bank 1 or Single Sensor)	<Ref. to GD(H4DOTC)-95, DTC P0327 KNOCK SENSOR 1 CIRCUIT LOW INPUT (BANK 1 OR SINGLE SENSOR), Diagnostic Trouble Code (DTC) Detecting Criteria.>
P0328	Knock Sensor 1 Circuit High Input (Bank 1 or Single Sensor)	<Ref. to GD(H4DOTC)-97, DTC P0328 KNOCK SENSOR 1 CIRCUIT HIGH INPUT (BANK 1 OR SINGLE SENSOR), Diagnostic Trouble Code (DTC) Detecting Criteria.>
P0335	Crankshaft Position Sensor "A" Circuit	<Ref. to GD(H4DOTC)-99, DTC P0335 CRANKSHAFT POSITION SENSOR "A" CIRCUIT, Diagnostic Trouble Code (DTC) Detecting Criteria.>
P0336	Crankshaft Position Sensor "A" Circuit Range/Performance	<Ref. to GD(H4DOTC)-101, DTC P0336 CRANKSHAFT POSITION SENSOR "A" CIRCUIT RANGE/PERFORMANCE, Diagnostic Trouble Code (DTC) Detecting Criteria.>
P0340	Camshaft Position Sensor "A" Circuit (Bank 1 or Single Sensor)	<Ref. to GD(H4DOTC)-103, DTC P0340 CAMSHAFT POSITION SENSOR "A" CIRCUIT (BANK 1 OR SINGLE SENSOR), Diagnostic Trouble Code (DTC) Detecting Criteria.>
P0341	Camshaft Position Sensor "A" Circuit Range/Performance (Bank 1 or Single Sensor)	<Ref. to GD(H4DOTC)-108, ECM OPERATING AT DTC SETTING, DTC P0341 CAMSHAFT POSITION SENSOR "A" CIRCUIT RANGE/PERFORMANCE (BANK 1 OR SINGLE SENSOR), Diagnostic Trouble Code (DTC) Detecting Criteria.>
P0420	Catalyst System Efficiency Below Threshold (Bank 1)	<Ref. to GD(H4DOTC)-109, DTC P0420 CATALYST SYSTEM EFFICIENCY BELOW THRESHOLD (BANK 1), Diagnostic Trouble Code (DTC) Detecting Criteria.>
P0442	Evaporative Emission Control System Leak Detected (Small Leak)	<Ref. to GD(H4DOTC)-112, DTC P0442 EVAPORATIVE EMISSION CONTROL SYSTEM LEAK DETECTED (SMALL LEAK), Diagnostic Trouble Code (DTC) Detecting Criteria.>
P0447	Evaporative Emission Control System Vent Control Circuit Open	<Ref. to GD(H4DOTC)-135, DTC P0447 EVAPORATIVE EMISSION CONTROL SYSTEM VENT CONTROL CIRCUIT OPEN, Diagnostic Trouble Code (DTC) Detecting Criteria.>
P0448	Evaporative Emission Control System Vent Control Circuit Shorted	<Ref. to GD(H4DOTC)-137, DTC P0448 EVAPORATIVE EMISSION CONTROL SYSTEM VENT CONTROL CIRCUIT SHORTED, Diagnostic Trouble Code (DTC) Detecting Criteria.>
P0451	Evaporative Emission Control System Pressure Sensor Range/Performance	<Ref. to GD(H4DOTC)-139, DTC P0451 EVAPORATIVE EMISSION CONTROL SYSTEM PRESSURE SENSOR RANGE/PERFORMANCE, Diagnostic Trouble Code (DTC) Detecting Criteria.>
P0452	Evaporative Emission Control System Pressure Sensor Low Input	<Ref. to GD(H4DOTC)-141, DTC P0452 EVAPORATIVE EMISSION CONTROL SYSTEM PRESSURE SENSOR LOW INPUT, Diagnostic Trouble Code (DTC) Detecting Criteria.>
P0453	Evaporative Emission Control System Pressure Sensor High Input	<Ref. to GD(H4DOTC)-143, DTC P0453 EVAPORATIVE EMISSION CONTROL SYSTEM PRESSURE SENSOR HIGH INPUT, Diagnostic Trouble Code (DTC) Detecting Criteria.>
P0456	Evaporative Emission Control System Leak Detected (Very Small Leak)	<Ref. to GD(H4DOTC)-144, DTC P0456 EVAPORATIVE EMISSION CONTROL SYSTEM LEAK DETECTED (VERY SMALL LEAK), Diagnostic Trouble Code (DTC) Detecting Criteria.>
P0457	Evaporative Emission Control System Leak Detected (Fuel Cap Loose/Off)	<Ref. to GD(H4DOTC)-144, DTC P0457 EVAPORATIVE EMISSION CONTROL SYSTEM LEAK DETECTED (FUEL CAP LOOSE/OFF), Diagnostic Trouble Code (DTC) Detecting Criteria.>
P0458	Evaporative Emission Control System Purge Control Valve Circuit Low	<Ref. to GD(H4DOTC)-145, DTC P0458 EVAPORATIVE EMISSION CONTROL SYSTEM PURGE CONTROL VALVE CIRCUIT LOW, Diagnostic Trouble Code (DTC) Detecting Criteria.>
P0459	Evaporative Emission Control System Purge Control Valve Circuit High	<Ref. to GD(H4DOTC)-147, DTC P0459 EVAPORATIVE EMISSION CONTROL SYSTEM PURGE CONTROL VALVE CIRCUIT HIGH, Diagnostic Trouble Code (DTC) Detecting Criteria.>
P0461	Fuel Level Sensor Circuit Range/Performance	<Ref. to GD(H4DOTC)-149, DTC P0461 FUEL LEVEL SENSOR CIRCUIT RANGE/PERFORMANCE, Diagnostic Trouble Code (DTC) Detecting Criteria.>

# List of Diagnostic Trouble Code (DTC)

GENERAL DESCRIPTION

DTC	Description	Index
P0462	Fuel Level Sensor Circuit Low Input	<Ref. to GD(H4DOTC)-151, DTC P0462 FUEL LEVEL SENSOR CIRCUIT LOW INPUT, Diagnostic Trouble Code (DTC) Detecting Criteria.>
P0463	Fuel Level Sensor Circuit High Input	<Ref. to GD(H4DOTC)-153, DTC P0463 FUEL LEVEL SENSOR CIRCUIT HIGH INPUT, Diagnostic Trouble Code (DTC) Detecting Criteria.>
P0464	Fuel Level Sensor Circuit Intermittent	<Ref. to GD(H4DOTC)-155, DTC P0464 FUEL LEVEL SENSOR CIRCUIT INTERMITTENT, Diagnostic Trouble Code (DTC) Detecting Criteria.>
P0483	Cooling Fan Rationality Check	<Ref. to GD(H4DOTC)-158, DTC P0483 COOLING FAN RATIONALITY CHECK, Diagnostic Trouble Code (DTC) Detecting Criteria.>
P0502	Vehicle Speed Sensor Circuit Low Input	<Ref. to GD(H4DOTC)-160, DTC P0502 VEHICLE SPEED SENSOR CIRCUIT LOW INPUT, Diagnostic Trouble Code (DTC) Detecting Criteria.>
P0503	Vehicle Speed Sensor Intermittent/Erratic/High	<Ref. to GD(H4DOTC)-161, DTC P0503 VEHICLE SPEED SENSOR INTERMITTENT/ERRATIC/HIGH, Diagnostic Trouble Code (DTC) Detecting Criteria.>
P0506	Idle Control System Rpm Lower Than Expected	<Ref. to GD(H4DOTC)-162, DTC P0506 IDLE CONTROL SYSTEM RPM LOWER THAN EXPECTED, Diagnostic Trouble Code (DTC) Detecting Criteria.>
P0507	Idle Control System Rpm Higher Than Expected	<Ref. to GD(H4DOTC)-164, DTC P0507 IDLE CONTROL SYSTEM RPM HIGHER THAN EXPECTED, Diagnostic Trouble Code (DTC) Detecting Criteria.>
P0508	Idle Control System Circuit Low	<Ref. to GD(H4DOTC)-166, DTC P0508 IDLE CONTROL SYSTEM CIRCUIT LOW, Diagnostic Trouble Code (DTC) Detecting Criteria.>
P0509	Idle Control System Circuit High	<Ref. to GD(H4DOTC)-168, DTC P0509 IDLE CONTROL SYSTEM CIRCUIT HIGH, Diagnostic Trouble Code (DTC) Detecting Criteria.>
P0512	Starter Request Circuit	<Ref. to GD(H4DOTC)-170, DTC P0512 STARTER REQUEST CIRCUIT, Diagnostic Trouble Code (DTC) Detecting Criteria.>
P0519	Idle Control System Malfunction (Fail-Safe)	<Ref. to GD(H4DOTC)-171, DTC P0519 IDLE CONTROL SYSTEM MALFUNCTION (FAIL-SAFE), Diagnostic Trouble Code (DTC) Detecting Criteria.>
P0545	Exhaust Gas Temperature Sensor Circuit Low-Bank 1	<Ref. to GD(H4DOTC)-173, DTC P0545 EXHAUST GAS TEMPERATURE SENSOR CIRCUIT LOW-BANK 1, Diagnostic Trouble Code (DTC) Detecting Criteria.>
P0546	Exhaust Gas Temperature Sensor Circuit High-Bank 1	<Ref. to GD(H4DOTC)-175, DTC P0546 EXHAUST GAS TEMPERATURE SENSOR CIRCUIT HIGH-BANK 1, Diagnostic Trouble Code (DTC) Detecting Criteria.>
P0565	Cruise Control ON Signal	<Ref. to GD(H4DOTC)-177, DTC P0565 CRUISE CONTROL ON SIGNAL, Diagnostic Trouble Code (DTC) Detecting Criteria.>
P0604	Internal Control Module Random Access Memory (RAM) Error	<Ref. to GD(H4DOTC)-178, DTC P0604 INTERNAL CONTROL MODULE RANDOM ACCESS MEMORY (RAM) ERROR, Diagnostic Trouble Code (DTC) Detecting Criteria.>
P0691	Cooling Fan 1 Control Circuit Low	<Ref. to GD(H4DOTC)-179, DTC P0691 COOLING FAN 1 CONTROL CIRCUIT LOW, Diagnostic Trouble Code (DTC) Detecting Criteria.>
P0692	Cooling Fan 1 Control Circuit High	<Ref. to GD(H4DOTC)-180, DTC P0692 COOLING FAN 1 CONTROL CIRCUIT HIGH, Diagnostic Trouble Code (DTC) Detecting Criteria.>
P0703	Torque Converter/Brake Switch "B" Circuit	<Ref. to GD(H4DOTC)-181, DTC P0703 TORQUE CONVERTER/BRAKE SWITCH "B" CIRCUIT, Diagnostic Trouble Code (DTC) Detecting Criteria.>
P0705	Transmission Range Sensor Circuit (PRNDL Input)	<Ref. to GD(H4DOTC)-182, DTC P0705 TRANSMISSION RANGE SENSOR CIRCUIT (PRNDL INPUT), Diagnostic Trouble Code (DTC) Detecting Criteria.>
P0710	Transmission Fluid Temperature Sensor Circuit	<Ref. to GD(H4DOTC)-183, DTC P0710 TRANSMISSION FLUID TEMPERATURE SENSOR CIRCUIT, Diagnostic Trouble Code (DTC) Detecting Criteria.>
P0716	Input/Turbine Speed Sensor Circuit Range/Performance	<Ref. to GD(H4DOTC)-184, DTC P0716 INPUT/TURBINE SPEED SENSOR CIRCUIT RANGE/PERFORMANCE, Diagnostic Trouble Code (DTC) Detecting Criteria.>
P0720	Output Speed Sensor Circuit	<Ref. to GD(H4DOTC)-185, DTC P0720 OUTPUT SPEED SENSOR CIRCUIT, Diagnostic Trouble Code (DTC) Detecting Criteria.>



## List of Diagnostic Trouble Code (DTC)

### GENERAL DESCRIPTION

DTC	Description	Index
P0726	Engine Speed Input Circuit Range/Performance	<Ref. to GD(H4DOTC)-186, DTC P0726 ENGINE SPEED INPUT CIRCUIT RANGE/PERFORMANCE, Diagnostic Trouble Code (DTC) Detecting Criteria.>
P0731	Gear 1 Incorrect Ratio	<Ref. to GD(H4DOTC)-187, DTC P0731 GEAR 1 INCORRECT RATIO, Diagnostic Trouble Code (DTC) Detecting Criteria.>
P0732	Gear 2 Incorrect Ratio	<Ref. to GD(H4DOTC)-188, DTC P0732 GEAR 2 INCORRECT RATIO, Diagnostic Trouble Code (DTC) Detecting Criteria.>
P0733	Gear 3 Incorrect Ratio	<Ref. to GD(H4DOTC)-189, DTC P0733 GEAR 3 INCORRECT RATIO, Diagnostic Trouble Code (DTC) Detecting Criteria.>
P0734	Gear 4 Incorrect Ratio	<Ref. to GD(H4DOTC)-190, DTC P0734 GEAR 4 INCORRECT RATIO, Diagnostic Trouble Code (DTC) Detecting Criteria.>
P0741	Torque Converter Clutch Circuit Performance or Stuck OFF	<Ref. to GD(H4DOTC)-191, DTC P0741 TORQUE CONVERTER CLUTCH CIRCUIT PERFORMANCE OR STUCK OFF, Diagnostic Trouble Code (DTC) Detecting Criteria.>
P0743	Torque Converter Clutch Circuit Electrical	<Ref. to GD(H4DOTC)-192, DTC P0743 TORQUE CONVERTER CLUTCH CIRCUIT ELECTRICAL, Diagnostic Trouble Code (DTC) Detecting Criteria.>
P0748	Pressure Control Solenoid "A" Electrical	<Ref. to GD(H4DOTC)-193, DTC P0748 PRESSURE CONTROL SOLENOID "A" ELECTRICAL, Diagnostic Trouble Code (DTC) Detecting Criteria.>
P0753	Shift Solenoid "A" Electrical	<Ref. to GD(H4DOTC)-194, DTC P0753 SHIFT SOLENOID "A" ELECTRICAL, Diagnostic Trouble Code (DTC) Detecting Criteria.>
P0758	Shift Solenoid "B" Electrical	<Ref. to GD(H4DOTC)-195, DTC P0758 SHIFT SOLENOID "B" ELECTRICAL, Diagnostic Trouble Code (DTC) Detecting Criteria.>
P0771	Shift Solenoid "E" Performance or Stuck OFF	<Ref. to GD(H4DOTC)-196, DTC P0771 SHIFT SOLENOID "E" PERFORMANCE OR STUCK OFF, Diagnostic Trouble Code (DTC) Detecting Criteria.>
P0778	Pressure Control Solenoid "B" Electrical	<Ref. to GD(H4DOTC)-197, DTC P0778 PRESSURE CONTROL SOLENOID "B" ELECTRICAL, Diagnostic Trouble Code (DTC) Detecting Criteria.>
P0785	Shift/Timing Solenoid	<Ref. to GD(H4DOTC)-198, DTC P0785 SHIFT/TIMING SOLENOID, Diagnostic Trouble Code (DTC) Detecting Criteria.>
P0851	Neutral Switch Input Circuit Low (AT Model)	<Ref. to GD(H4DOTC)-199, DTC P0851 NEUTRAL SWITCH INPUT CIRCUIT LOW (AT MODEL), Diagnostic Trouble Code (DTC) Detecting Criteria.>
P0851	Neutral Switch Input Circuit Low (MT Model)	<Ref. to GD(H4DOTC)-200, DTC P0851 NEUTRAL SWITCH INPUT CIRCUIT LOW (MT MODEL), Diagnostic Trouble Code (DTC) Detecting Criteria.>
P0852	Neutral Switch Input Circuit High (AT Model)	<Ref. to GD(H4DOTC)-201, DTC P0852 NEUTRAL SWITCH INPUT CIRCUIT HIGH (AT MODEL), Diagnostic Trouble Code (DTC) Detecting Criteria.>
P0852	Neutral Switch Input Circuit High (MT Model)	<Ref. to GD(H4DOTC)-202, DTC P0852 NEUTRAL SWITCH INPUT CIRCUIT HIGH (MT MODEL), Diagnostic Trouble Code (DTC) Detecting Criteria.>
P0864	TCM Communication Circuit Range/Performance	<Ref. to GD(H4DOTC)-203, DTC P0864 TCM COMMUNICATION CIRCUIT RANGE/PERFORMANCE, Diagnostic Trouble Code (DTC) Detecting Criteria.>
P0865	TCM Communication Circuit Low	<Ref. to GD(H4DOTC)-204, DTC P0865 TCM COMMUNICATION CIRCUIT LOW, Diagnostic Trouble Code (DTC) Detecting Criteria.>
P0866	TCM Communication Circuit High	<Ref. to GD(H4DOTC)-205, DTC P0866 TCM COMMUNICATION CIRCUIT HIGH, Diagnostic Trouble Code (DTC) Detecting Criteria.>
P1086	Tumble Generated Valve Position Sensor 2 Circuit Low	<Ref. to GD(H4DOTC)-206, DTC P1086 TUMBLE GENERATED VALVE POSITION SENSOR 2 CIRCUIT LOW, Diagnostic Trouble Code (DTC) Detecting Criteria.>
P1087	Tumble Generated Valve Position Sensor 2 Circuit High	<Ref. to GD(H4DOTC)-208, DTC P1087 TUMBLE GENERATED VALVE POSITION SENSOR 2 CIRCUIT HIGH, Diagnostic Trouble Code (DTC) Detecting Criteria.>
P1088	Tumble Generated Valve Position Sensor 1 Circuit Low	<Ref. to GD(H4DOTC)-210, DTC P1088 TUMBLE GENERATED VALVE POSITION SENSOR 1 CIRCUIT LOW, Diagnostic Trouble Code (DTC) Detecting Criteria.>

# List of Diagnostic Trouble Code (DTC)

GENERAL DESCRIPTION

DTC	Description	Index
P1089	Tumble Generated Valve Position Sensor 1 Circuit High	<Ref. to GD(H4DOTC)-212, DTC P1089 TUMBLE GENERATED VALVE POSITION SENSOR 1 CIRCUIT HIGH, Diagnostic Trouble Code (DTC) Detecting Criteria.>
P1090	Tumble Generated Valve System 1 (Valve Open)	<Ref. to GD(H4DOTC)-214, DTC P1090 TUMBLE GENERATED VALVE SYSTEM 1 (VALVE OPEN), Diagnostic Trouble Code (DTC) Detecting Criteria.>
P1091	Tumble Generated Valve System 1 (Valve Close)	<Ref. to GD(H4DOTC)-215, DTC P1091 TUMBLE GENERATED VALVE SYSTEM 1 (VALVE CLOSE), Diagnostic Trouble Code (DTC) Detecting Criteria.>
P1092	Tumble Generated Valve System 2 (Valve Open)	<Ref. to GD(H4DOTC)-216, DTC P1092 TUMBLE GENERATED VALVE SYSTEM 2 (VALVE OPEN), Diagnostic Trouble Code (DTC) Detecting Criteria.>
P1093	Tumble Generated Valve System 2 (Valve Close)	<Ref. to GD(H4DOTC)-217, DTC P1093 TUMBLE GENERATED VALVE SYSTEM 2 (VALVE CLOSE), Diagnostic Trouble Code (DTC) Detecting Criteria.>
P1094	Tumble Generated Valve Signal 1 Circuit Malfunction (Open)	<Ref. to GD(H4DOTC)-218, DTC P1094 TUMBLE GENERATED VALVE SIGNAL 1 CIRCUIT MALFUNCTION (OPEN), Diagnostic Trouble Code (DTC) Detecting Criteria.>
P1095	Tumble Generated Valve Signal 1 Circuit Malfunction (Short)	<Ref. to GD(H4DOTC)-220, DTC P1095 TUMBLE GENERATED VALVE SIGNAL 1 CIRCUIT MALFUNCTION (SHORT), Diagnostic Trouble Code (DTC) Detecting Criteria.>
P1096	Tumble Generated Valve Signal 2 Circuit Malfunction (Open)	<Ref. to GD(H4DOTC)-222, DTC P1096 TUMBLE GENERATED VALVE SIGNAL 2 CIRCUIT MALFUNCTION (OPEN), Diagnostic Trouble Code (DTC) Detecting Criteria.>
P1097	Tumble Generated Valve Signal 2 Circuit Malfunction (Short)	<Ref. to GD(H4DOTC)-224, DTC P1097 TUMBLE GENERATED VALVE SIGNAL 2 CIRCUIT MALFUNCTION (SHORT), Diagnostic Trouble Code (DTC) Detecting Criteria.>
P1110	Atmospheric Pressure Sensor Circuit Malfunction (Low Input)	<Ref. to GD(H4DOTC)-226, DTC P1110 ATMOSPHERIC PRESSURE SENSOR CIRCUIT MALFUNCTION (LOW INPUT), Diagnostic Trouble Code (DTC) Detecting Criteria.>
P1111	Atmospheric Pressure Sensor Circuit Malfunction (High Input)	<Ref. to GD(H4DOTC)-227, DTC P1111 ATMOSPHERIC PRESSURE SENSOR CIRCUIT MALFUNCTION (HIGH INPUT), Diagnostic Trouble Code (DTC) Detecting Criteria.>
P1134	A/F Sensor Micro-Computer Problem	<Ref. to GD(H4DOTC)-228, DTC P1134 A/F SENSOR MICRO-COMPUTER PROBLEM, Diagnostic Trouble Code (DTC) Detecting Criteria.>
P1152	O <sub>2</sub> Sensor Circuit Range/Performance (Low) (Bank 1 Sensor 1)	<Ref. to GD(H4DOTC)-230, DTC P1152 O <sub>2</sub> SENSOR CIRCUIT RANGE/PERFORMANCE (LOW) (BANK1 SENSOR1), Diagnostic Trouble Code (DTC) Detecting Criteria.>
P1153	O <sub>2</sub> Sensor Circuit Range/Performance (High) (Bank 1 Sensor 1)	<Ref. to GD(H4DOTC)-233, DTC P1153 O <sub>2</sub> SENSOR CIRCUIT RANGE/PERFORMANCE (HIGH) (BANK1 SENSOR1), Diagnostic Trouble Code (DTC) Detecting Criteria.>
P1301	Misfire Detected (High Temperature Exhaust Gas)	<Ref. to GD(H4DOTC)-236, DTC P1301 MISFIRE DETECTED (HIGH TEMPERATURE EXHAUST GAS), Diagnostic Trouble Code (DTC) Detecting Criteria.>
P1312	Exhaust Gas Temperature Sensor Malfunction	<Ref. to GD(H4DOTC)-237, DTC P1312 EXHAUST GAS TEMPERATURE SENSOR MALFUNCTION, Diagnostic Trouble Code (DTC) Detecting Criteria.>
P1400	Fuel Tank Pressure Control Solenoid Valve Circuit Low	<Ref. to GD(H4DOTC)-238, DTC P1400 FUEL TANK PRESSURE CONTROL SOLENOID VALVE CIRCUIT LOW, Diagnostic Trouble Code (DTC) Detecting Criteria.>
P1420	Fuel Tank Pressure Control Sol. Valve Circuit High	<Ref. to GD(H4DOTC)-240, DTC P1420 FUEL TANK PRESSURE CONTROL SOL. VALVE CIRCUIT HIGH, Diagnostic Trouble Code (DTC) Detecting Criteria.>
P1443	Vent Control Solenoid Valve Function Problem	<Ref. to GD(H4DOTC)-241, DTC P1443 VENT CONTROL SOLENOID VALVE FUNCTION PROBLEM, Diagnostic Trouble Code (DTC) Detecting Criteria.>

## List of Diagnostic Trouble Code (DTC)

### GENERAL DESCRIPTION

DTC	Description	Index
P1446	Fuel Tank Sensor Control Valve Circuit Low	<Ref. to GD(H4DOTC)-242, DTC P1446 FUEL TANK SENSOR CONTROL VALVE CIRCUIT LOW, Diagnostic Trouble Code (DTC) Detecting Criteria.>
P1447	Fuel Tank Sensor Control Valve Circuit High	<Ref. to GD(H4DOTC)-244, DTC P1447 FUEL TANK SENSOR CONTROL VALVE CIRCUIT HIGH, Diagnostic Trouble Code (DTC) Detecting Criteria.>
P1448	Fuel Tank Sensor Control Valve Range Performance	<Ref. to GD(H4DOTC)-246, DTC P1448 FUEL TANK SENSOR CONTROL VALVE RANGE PERFORMANCE, Diagnostic Trouble Code (DTC) Detecting Criteria.>
P1491	Positive Crankcase Ventilation (Blow-By) Function Problem	<Ref. to GD(H4DOTC)-249, DTC P1491 POSITIVE CRANKCASE VENTILATION (BLOW-BY) FUNCTION PROBLEM, Diagnostic Trouble Code (DTC) Detecting Criteria.>
P1518	Starter Switch Circuit Low Input	<Ref. to GD(H4DOTC)-251, DTC P1518 STARTER SWITCH CIRCUIT LOW INPUT, Diagnostic Trouble Code (DTC) Detecting Criteria.>
P1544	Exhaust Gas Temperature Too High	<Ref. to GD(H4DOTC)-252, DTC P1544 EXHAUST GAS TEMPERATURE TOO HIGH, Diagnostic Trouble Code (DTC) Detecting Criteria.>
P1560	Back-Up Voltage Circuit Malfunction	<Ref. to GD(H4DOTC)-253, DTC P1560 BACK-UP VOLTAGE CIRCUIT MALFUNCTION, Diagnostic Trouble Code (DTC) Detecting Criteria.>
P1700	Throttle Position Sensor Circuit Malfunction For AT	<Ref. to GD(H4DOTC)-254, DTC P1700 THROTTLE POSITION SENSOR CIRCUIT MALFUNCTION FOR AT, Diagnostic Trouble Code (DTC) Detecting Criteria.>
P1711	Engine Torque Control Signal #1 Circuit Malfunction	<Ref. to GD(H4DOTC)-256, DTC P1711 ENGINE TORQUE CONTROL SIGNAL #1 CIRCUIT MALFUNCTION, Diagnostic Trouble Code (DTC) Detecting Criteria.>
P1712	Engine Torque Control Signal #2 Circuit Malfunction	<Ref. to GD(H4DOTC)-257, DTC P1712 ENGINE TORQUE CONTROL SIGNAL #2 CIRCUIT MALFUNCTION, Diagnostic Trouble Code (DTC) Detecting Criteria.>
P2096	Post Catalyst Fuel Trim System Too Lean Bank 1	<Ref. to GD(H4DOTC)-258, DTC P2096 POST CATALYST FUEL TRIM SYSTEM TOO LEAN BANK 1, Diagnostic Trouble Code (DTC) Detecting Criteria.>
P2097	Post Catalyst Fuel Trim System Too Rich Bank 1	<Ref. to GD(H4DOTC)-260, DTC P2097 POST CATALYST FUEL TRIM SYSTEM TOO RICH BANK 1, Diagnostic Trouble Code (DTC) Detecting Criteria.>



# Diagnostic Trouble Code (DTC) Detecting Criteria

GENERAL DESCRIPTION

## 2. Diagnostic Trouble Code (DTC) Detecting Criteria

### A: DTC P0030 HO2S HEATER CONTROL CIRCUIT (BANK 1 SENSOR 1)

#### 1. OUTLINE OF DIAGNOSIS

Detect the malfunction of front oxygen (A/F) sensor heater.

Judge NG when impedance of front oxygen (A/F) sensor is larger than the standard value by referring to the engine condition such as fuel shut-off in deceleration, etc.

#### 2. COMPONENT DESCRIPTION

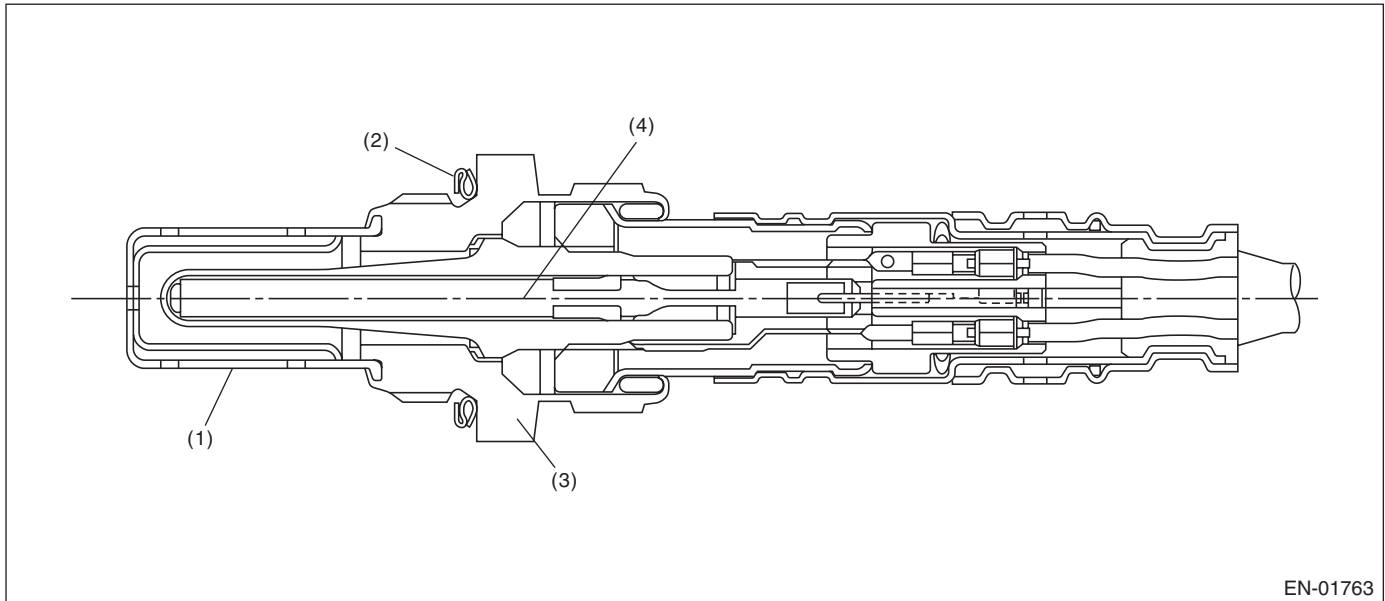

EN-01763

- (1) Protection tube
- (2) Gasket
- (3) Sensor housing
- (4) Ceramic heater

#### 3. ENABLE CONDITION

Secondary Parameters	Enable Conditions
Time needed for all secondary parameters to be in enable conditions	60 seconds or more
Battery voltage	> 10.9 V
After fuel shut-off	20 seconds or more

#### 4. GENERAL DRIVING CYCLE

Perform diagnosis continuously in 60 seconds after starting engine.

#### 5. DIAGNOSTIC METHOD

Judge NG when the continuous time of completing the malfunction criteria below becomes more than the time needed for diagnosis (10 seconds). Judge OK and clear NG when the continuous time of not completing the malfunction criteria below becomes more than the time needed for diagnosis (10 seconds).

##### Judgment Value

Malfunction Criteria	Threshold Value
Impedance of front oxygen (A/F) sensor	> 52 $\Omega$

**Time Needed for Diagnosis:** 10 seconds

# Diagnostic Trouble Code (DTC) Detecting Criteria

## GENERAL DESCRIPTION

---

**Malfunction Indicator Light Illumination:** Illuminates when malfunction occurs in 2 continuous driving cycles.

### 6. DTC CLEAR CONDITION

- When the OK idling cycle was completed 40 times in a row
- When "Clear Memory" was performed

### 7. MALFUNCTION INDICATOR LIGHT CLEAR CONDITION

- When the OK driving cycle was completed 3 times in a row
- When "Clear Memory" was performed

### 8. FAIL SAFE

- Front oxygen (A/F) sensor main learning correction: Not allowed to calculate
- Correction when re-starting at high temperature: Normally minimum value 0.3 → 0
- Purge control: Not allowed to purge

### 9. ECM OPERATING AT DTC SETTING

Memorize the freeze frame data. (For test mode \$02)

# Diagnostic Trouble Code (DTC) Detecting Criteria

GENERAL DESCRIPTION

## B: DTC P0031 HO2S HEATER CONTROL CIRCUIT LOW (BANK 1 SENSOR 1)

### 1. OUTLINE OF DIAGNOSIS

Detect the open or short circuit of front oxygen (A/F) sensor heater. Diagnosis is performed using front oxygen (A/F) sensor IC, and communication is established between front oxygen (A/F) sensor IC and main IC. Front oxygen (A/F) sensor IC judges NG when the data of voltage and current is abnormal with heater turned on or off.

### 2. COMPONENT DESCRIPTION

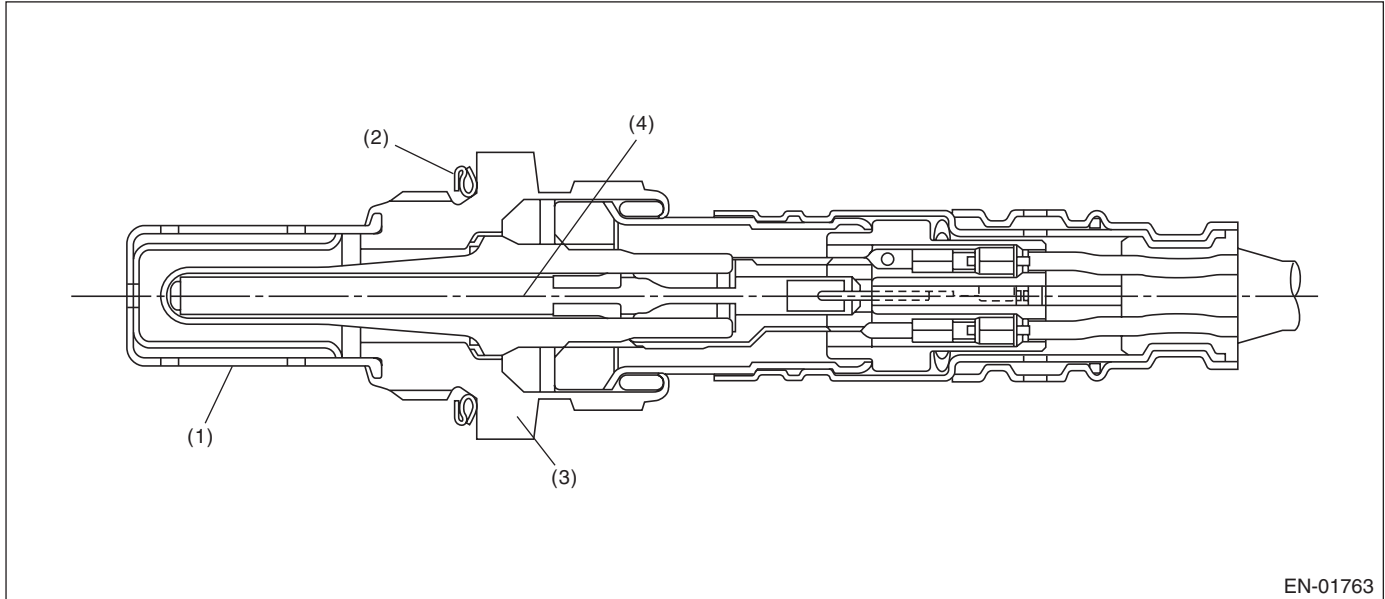

EN-01763

- (1) Protection tube
- (2) Gasket
- (3) Sensor housing
- (4) Ceramic heater

### 3. ENABLE CONDITION

Secondary Parameters	Enable Conditions
None	

### 4. GENERAL DRIVING CYCLE

Always perform diagnosis continuously.

### 5. DIAGNOSTIC METHOD

Front oxygen (A/F) sensor IC judges NG when the continuous time of completing the malfunction criteria below becomes more than the time needed for diagnosis (4.6 seconds). Front oxygen (A/F) sensor IC judges OK and clear NG when the malfunction criteria below are not completed.

#### Judgment Value

Malfunction Criteria	Threshold Value
Heater circuit	ON
• Voltage	< 5 V
• Current	< 1.5 A

**Time Needed for Diagnosis:** 4.6 seconds

**Malfunction Indicator Light Illumination:** Illuminates as soon as the malfunction occurs.

## Diagnostic Trouble Code (DTC) Detecting Criteria

### GENERAL DESCRIPTION

---

#### 6. DTC CLEAR CONDITION

- When the OK idling cycle was completed 40 times in a row
- When "Clear Memory" was performed

#### 7. MALFUNCTION INDICATOR LIGHT CLEAR CONDITION

- When the OK driving cycle was completed 3 times in a row
- When "Clear Memory" was performed

#### 8. FAIL SAFE

- Front oxygen (A/F) sensor IC communication: Not allowed to communicate
- Front oxygen (A/F) sensor main learning correction: Not allowed to calculate
- Correction when re-starting at high temperature: Normally minimum value 0.3 → 0
- Purge control: Not allowed to purge

#### 9. ECM OPERATING AT DTC SETTING

Memorize the freeze frame data. (For test mode \$02)

# Diagnostic Trouble Code (DTC) Detecting Criteria

GENERAL DESCRIPTION

## C: DTC P0032 HO2S HEATER CONTROL CIRCUIT HIGH (BANK 1 SENSOR 1)

### 1. OUTLINE OF DIAGNOSIS

Detect the open or short circuit of front oxygen (A/F) sensor heater. Diagnosis is performed using front oxygen (A/F) sensor IC, and communication is established between front oxygen (A/F) sensor IC and main IC. Front oxygen (A/F) sensor IC judges NG when the data of voltage and current is abnormal with heater turned on or off.

### 2. COMPONENT DESCRIPTION

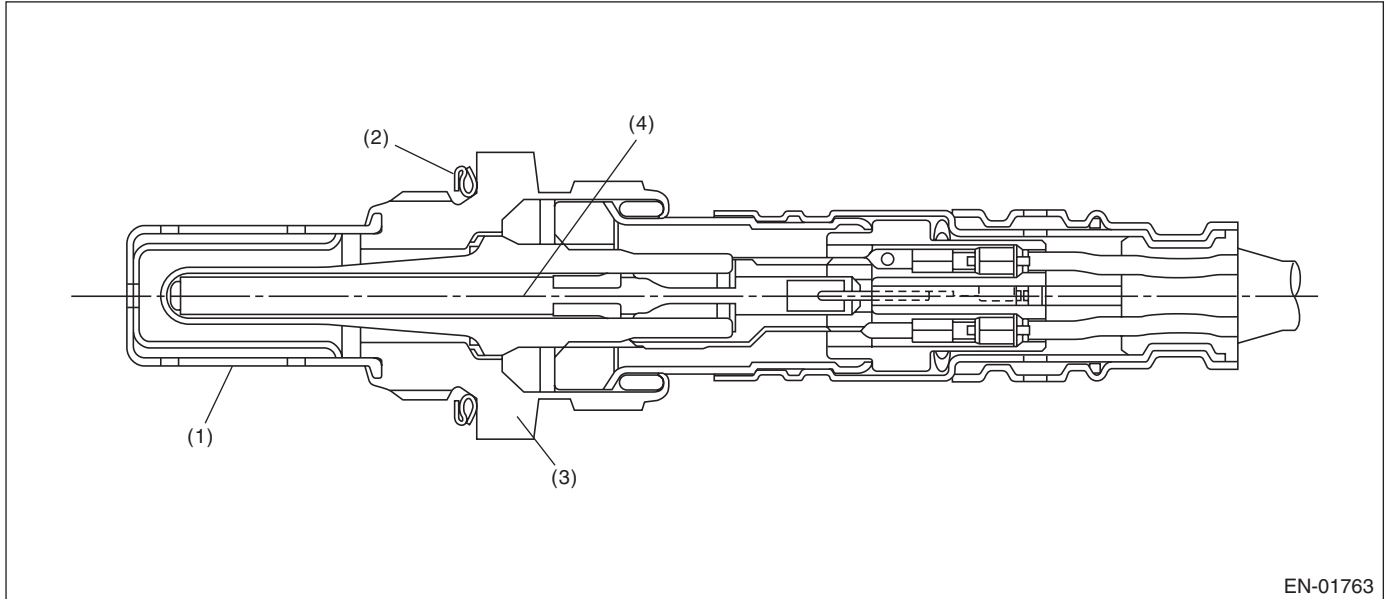

EN-01763

- (1) Protection tube
- (2) Gasket
- (3) Sensor housing
- (4) Ceramic heater

### 3. ENABLE CONDITION

Secondary Parameters	Enable Conditions
None	

### 4. GENERAL DRIVING CYCLE

Always perform diagnosis continuously.

### 5. DIAGNOSTIC METHOD

Front oxygen (A/F) sensor IC judges NG when the continuous time until completing one of the malfunction criteria below becomes more than the time needed for diagnosis (4.6 seconds). Front oxygen (A/F) sensor IC judges OK and clear NG when any of the malfunction criteria below are not completed.

#### Judgment Value

Malfunction Criteria	Threshold Value
Heater circuit	OFF
• Voltage	> 5 V
• Current	> 1.5 A
• Heater current	≥ 23 A

**Time Needed for Diagnosis:** 4.6 seconds

**Malfunction Indicator Light Illumination:** Illuminates as soon as the malfunction occurs.



## Diagnostic Trouble Code (DTC) Detecting Criteria

### GENERAL DESCRIPTION

---

#### 6. DTC CLEAR CONDITION

- When the OK idling cycle was completed 40 times in a row
- When "Clear Memory" was performed

#### 7. MALFUNCTION INDICATOR LIGHT CLEAR CONDITION

- When the OK driving cycle was completed 3 times in a row
- When "Clear Memory" was performed

#### 8. FAIL SAFE

- Front oxygen (A/F) sensor main learning correction: Not allowed to calculate
- Correction when re-starting at high temperature: Normally minimum value 0.3 → 0
- GST communication: Mode\$01 "Failure" is indicated in A/F feedback control condition
- Purge control: Not allowed to purge

#### 9. ECM OPERATING AT DTC SETTING

Memorize the freeze frame data. (For test mode \$02)

# Diagnostic Trouble Code (DTC) Detecting Criteria

GENERAL DESCRIPTION

## D: DTC P0037 HO2S HEATER CONTROL CIRCUIT LOW (BANK 1 SENSOR 2)

### 1. OUTLINE OF DIAGNOSIS

Detect open or short circuit of rear oxygen sensor heater. Rear oxygen sensor heater conducted the duty control, and the output terminal voltage at ON is 0 V and the output terminal voltage at OFF is the battery voltage. Calculate the Max. and Min. values of heater output terminal voltage. When the Max. value does not increased, it means Low malfunction.

### 2. COMPONENT DESCRIPTION

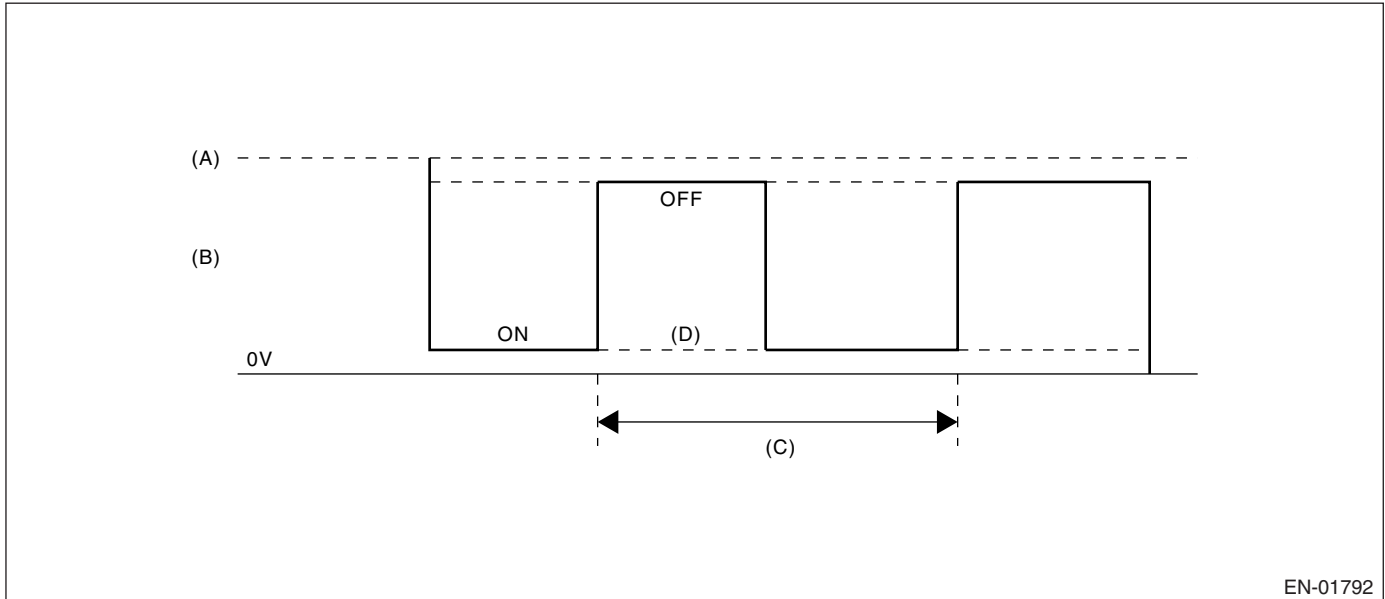

- (A) Battery voltage
- (B) Rear oxygen sensor heater output voltage
- (C) 262 milliseconds (cycles)
- (D) Low malfunction

### 3. ENABLE CONDITION

Secondary Parameters	Enable Conditions
Before or after starting the engine	After starting the engine
Battery voltage	> 10.9 V
Duty ratio of heater output	19.9 ←→ 79.6%
Engine speed	< 4,500 rpm

### 4. GENERAL DRIVING CYCLE

Perform the diagnosis continuously after engine starting.

### 5. DIAGNOSTIC METHOD

Judge NG when the continuous time of completing the malfunction criteria below becomes more than 5 seconds. Judge OK and clear the NG when the malfunction criteria below are not completed.

#### Judgment Value

Malfunction Criteria	Threshold Value
Max. heater voltage	< 10.12 V

**Time Needed for Diagnosis:** 5 seconds

**Malfunction Indicator Light Illumination:** Illuminates when malfunction occurs in 2 continuous driving cycles.

## Diagnostic Trouble Code (DTC) Detecting Criteria

### GENERAL DESCRIPTION

---

#### 6. DTC CLEAR CONDITION

- When the OK idling cycle was completed 40 times in a row
- When "Clear Memory" was performed

#### 7. MALFUNCTION INDICATOR LIGHT CLEAR CONDITION

- When the OK driving cycle was completed 3 times in a row
- When "Clear Memory" was performed

#### 8. FAIL SAFE

Sub feedback control: Not allowed

#### 9. ECM OPERATING AT DTC SETTING

Memorize the freeze frame data. (For test mode \$02)

# Diagnostic Trouble Code (DTC) Detecting Criteria

GENERAL DESCRIPTION

## E: DTC P0038 HO2S HEATER CONTROL CIRCUIT HIGH (BANK 1 SENSOR 2)

### 1. OUTLINE OF DIAGNOSIS

Detect open or short circuit of rear oxygen heater. Rear oxygen heater conducted the duty control, and the output terminal voltage at ON is 0 V and the output terminal voltage at OFF is the battery voltage. Calculate the Max. and Min. values of heater output terminal voltage. When the Min. value does not decreased, it means High malfunction.

### 2. COMPONENT DESCRIPTION

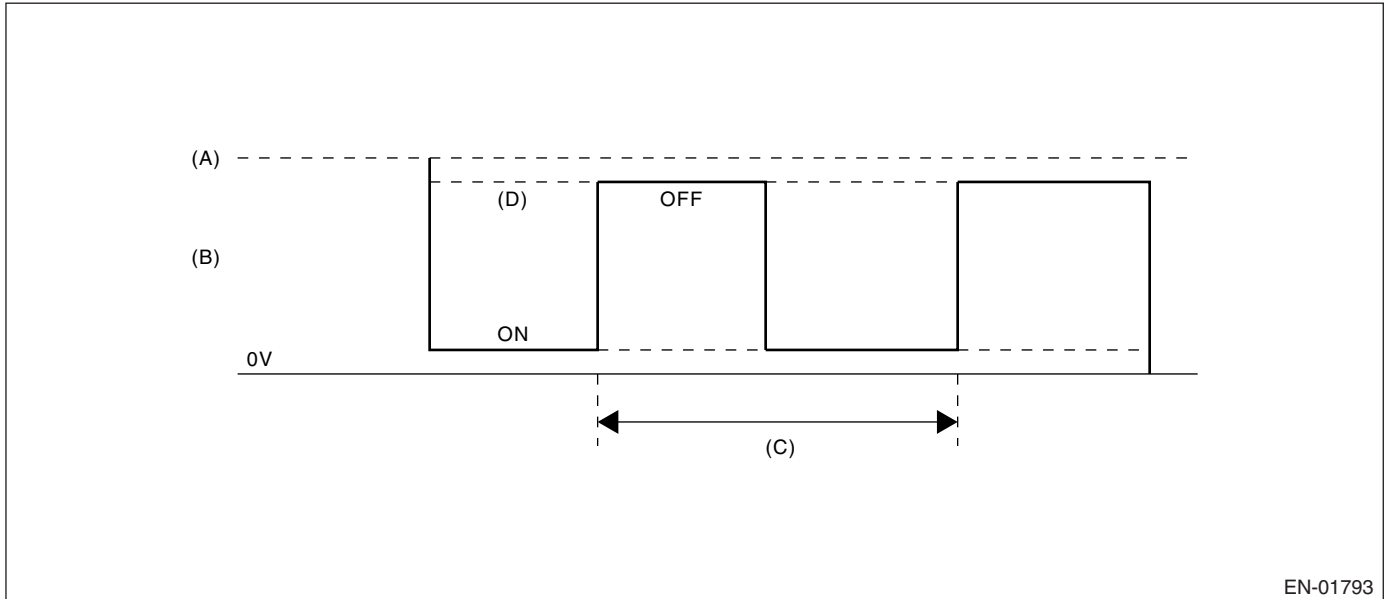

- (A) Battery voltage
- (B) Rear oxygen sensor heater output voltage
- (C) 262 milliseconds (cycles)
- (D) High malfunction

### 3. ENABLE CONDITION

Secondary Parameters	Enable Conditions
Before or after starting the engine	After starting the engine
Battery voltage	> 10.9 V
Duty ratio of heater output	19.9 ←→ 79.6%
Engine speed	< 4,500 rpm

### 4. GENERAL DRIVING CYCLE

Perform the diagnosis continuously after engine starting.

### 5. DIAGNOSTIC METHOD

Judge NG when the continuous time of completing the malfunction criteria below becomes more than 5 seconds. Judge OK and clear the NG when the malfunction criteria below are not completed.

#### Judgment Value

Malfunction Criteria	Threshold Value
Min. heater voltage	> 1.92 V

**Time Needed for Diagnosis:** 5 seconds

**Malfunction Indicator Light Illumination:** Illuminates when malfunction occurs in 2 continuous driving cycles.

## Diagnostic Trouble Code (DTC) Detecting Criteria

### GENERAL DESCRIPTION

---

#### 6. DTC CLEAR CONDITION

- When the OK idling cycle was completed 40 times in a row
- When "Clear Memory" was performed

#### 7. MALFUNCTION INDICATOR LIGHT CLEAR CONDITION

- When the OK driving cycle was completed 3 times in a row
- When "Clear Memory" was performed

#### 8. FAIL SAFE

Sub feedback control: Not allowed

#### 9. ECM OPERATING AT DTC SETTING

Memorize the freeze frame data. (For test mode \$02)



# Diagnostic Trouble Code (DTC) Detecting Criteria

GENERAL DESCRIPTION

## F: DTC P0068 MANIFOLD PRESSURE SENSOR RANGE/PERFORMANCE

### 1. OUTLINE OF DIAGNOSIS

Detect the malfunction of intake manifold pressure sensor output property. Judge NG when the intake air pressure AD value is Low whereas it seemed to be High from the viewpoint of engine condition, or when it is High whereas it seemed to be Low from the engine condition.

### 2. COMPONENT DESCRIPTION

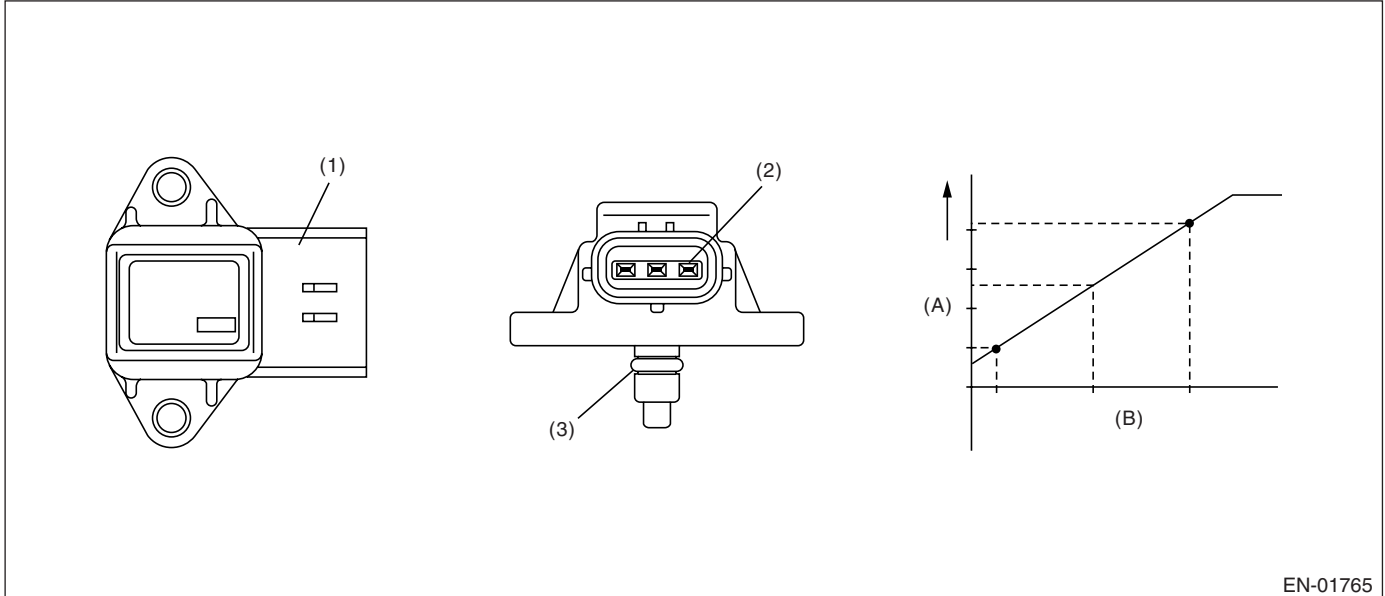

- (1) Connector
- (2) Terminal
- (3) O-ring

- (A) Output voltage
- (B) Absolute pressure

### 3. ENABLE CONDITION

Secondary Parameters	Enable Conditions
Engine coolant temperature	$\geq 75^{\circ}\text{C}$ (167°F)

### 4. GENERAL DRIVING CYCLE

Perform the diagnosis continuously after idling.

### 5. DIAGNOSTIC METHOD

#### • Abnormality Judgment

Judge NG when either Low side or High side becomes NG. Judge NG when the continuous time of completing the malfunction criteria below becomes more than 3 seconds.

#### Judgment Value

Malfunction Criteria	Threshold Value
Low side	
Engine speed	$< 2,500$ rpm
Throttle position	$\geq 10^{\circ}$
Output voltage	$< 1.0$ V
High side	
Engine speed	600 $\leftrightarrow$ 900 rpm
Throttle position	$< 1.3^{\circ}$
Output voltage	$\geq 2.6$ V

# Diagnostic Trouble Code (DTC) Detecting Criteria

## GENERAL DESCRIPTION

**Time Needed for Diagnosis:** 3 seconds

**Malfunction Indicator Light Illumination:** Illuminates when malfunction occurs in 2 continuous driving cycles.

### • Normality Judgment

Judge OK and clear the NG when both Low side and High side become OK. Judge OK when the malfunction criteria below are completed.

### Judgment Value

Malfunction Criteria	Threshold Value
Low side	
Engine speed	< 2,500 rpm
Throttle position	$\geq 10^\circ$
Output voltage	$\geq 1.0 \text{ V}$
High side	
Engine speed	600 $\leftrightarrow$ 900 rpm
Throttle position	< $1.3^\circ$
Output voltage	< 2.6 V

## 6. DTC CLEAR CONDITION

- When the OK idling cycle was completed 40 times in a row
- When "Clear Memory" was performed

## 7. MALFUNCTION INDICATOR LIGHT CLEAR CONDITION

- When the OK driving cycle was completed 3 times in a row
- When "Clear Memory" was performed

## 8. FAIL SAFE

- Intake manifold pressure sensor process: Estimate the pressure from engine load.
- ISC feedback: Not allowed to calculate the amount of feedback.
- Heavy fuel judgment: Not allowed to carry out the heavy judgment.

## 9. ECM OPERATING AT DTC SETTING

Memorize the freeze frame data. (For test mode \$02)

# Diagnostic Trouble Code (DTC) Detecting Criteria

GENERAL DESCRIPTION

## G: DTC P0101 MASS OR VOLUME AIR FLOW CIRCUIT RANGE/PERFORMANCE

### 1. OUTLINE OF DIAGNOSIS

Detect the malfunction of air flow sensor output property. Judge Low side NG when the air flow voltage indicates low value in spite of the driving condition that the air flow voltage might be high; otherwise, judge High side NG when the air flow voltage indicates high value in spite of the driving condition that the air flow voltage might be low. Judge air flow sensor property NG when the Low side or High side becomes NG.

### 2. COMPONENT DESCRIPTION

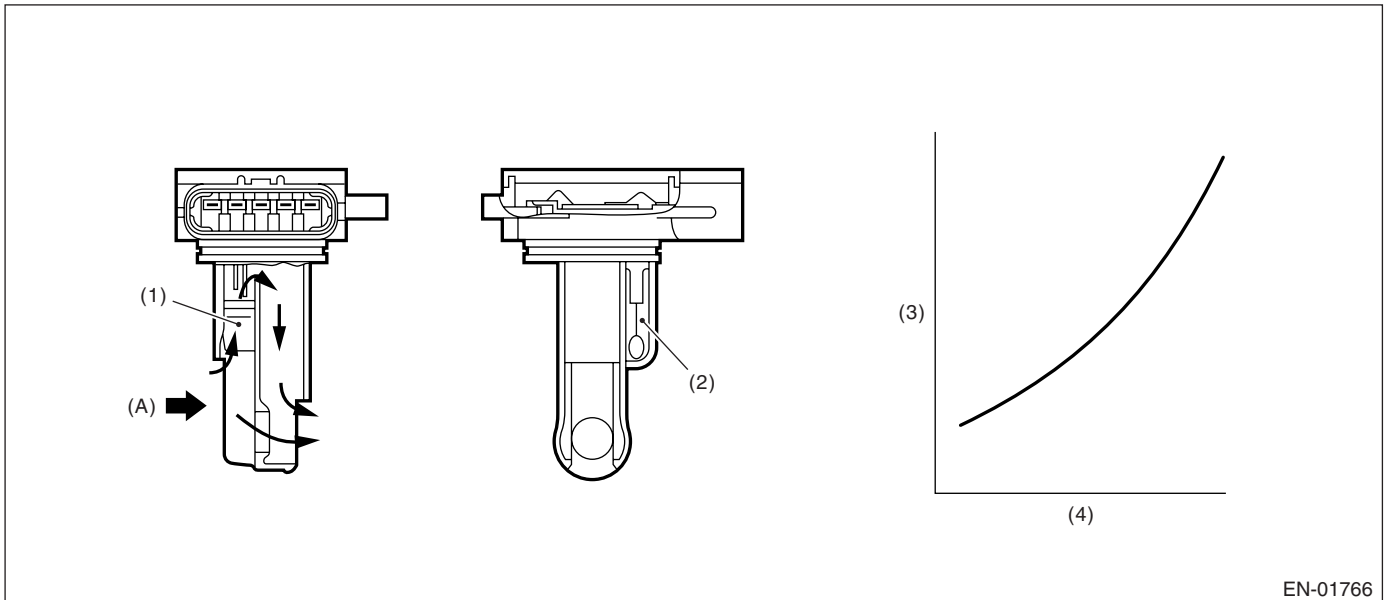

- (1) Air flow sensor
  - (2) Intake air temperature sensor
  - (3) Voltage (V)
  - (4) Intake air volume (kg/s)
- (A) Air

### 3. ENABLE CONDITION

Secondary Parameters	Enable Conditions
Engine coolant temperature	$\geq 75^{\circ}\text{C}$ ( $167^{\circ}\text{F}$ )

### 4. GENERAL DRIVING CYCLE

Perform the diagnosis continuously after idling.

### 5. DIAGNOSTIC METHOD

#### • Abnormality Judgment

Judge NG when the continuous time of completing the malfunction criteria below becomes more than the time needed for diagnosis.

# Diagnostic Trouble Code (DTC) Detecting Criteria

## GENERAL DESCRIPTION

### Judgment Value

Malfunction Criteria	Threshold Value
Low side NG	
Output voltage	< 1.5 V
Engine speed	≥ 2,500 rpm
Throttle angle	≥ 15°
Intake manifold pressure	≥ 53.3 kPa (400 mmHg, 15.7 inHg)
High side NG	
Output voltage	≥ 2.5 V
Engine speed	550 ↔ 900 rpm
Throttle angle	< 1.92°
Intake manifold pressure	< 46.7 kPa (350 mmHg, 13.8 inHg)

### Time Needed for Diagnosis:

Low side	3 seconds
High side	10 seconds

**Malfunction Indicator Light Illumination:** Illuminates when malfunction occurs in 2 continuous driving cycles.

### • Normality Judgment

Judge OK the when the malfunction criteria below are completed.

### Judgment Value

Malfunction Criteria	Threshold Value
Low side NG	
Output voltage	≥ 1.5 V
Engine speed	≥ 2,500 rpm
Throttle angle	≥ 15°
Intake manifold pressure	≥ 53.3 kPa (400 mmHg, 15.7 inHg)
High side NG	
Output voltage	< 2.5 V
Engine speed	550 ↔ 900 rpm
Throttle angle	< 1.92°
Intake manifold pressure	< 46.7 kPa (350 mmHg, 13.8 inHg)

## 6. DTC CLEAR CONDITION

- When the OK idling cycle was completed 40 times in a row
- When "Clear Memory" was performed

## 7. MALFUNCTION INDICATOR LIGHT CLEAR CONDITION

- When the OK driving cycle was completed 3 times in a row
- When "Clear Memory" was performed

## 8. FAIL SAFE

None

## 9. ECM OPERATING AT DTC SETTING

Memorize the freeze frame data. (For test mode \$02)

# Diagnostic Trouble Code (DTC) Detecting Criteria

GENERAL DESCRIPTION

## H: DTC P0102 MASS OR VOLUME AIR FLOW CIRCUIT LOW INPUT

### 1. OUTLINE OF DIAGNOSIS

Detect the open or short circuit of air flow sensor. Judge NG when out of the standard value.

### 2. COMPONENT DESCRIPTION

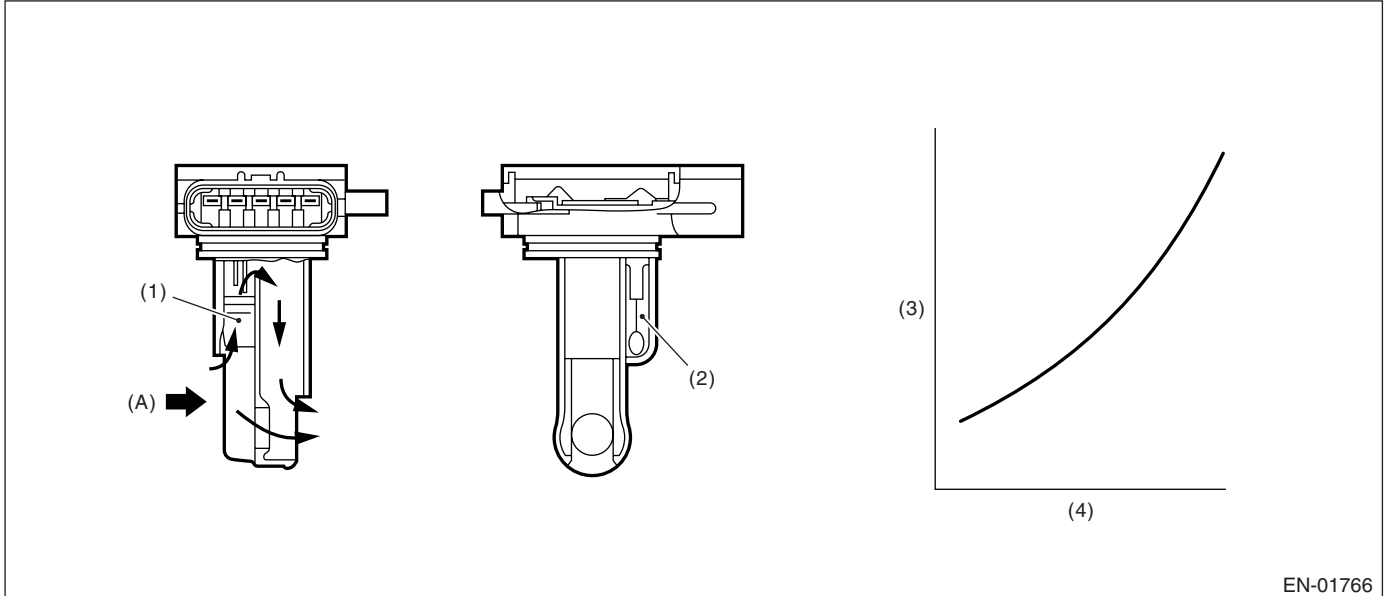

- (1) Air flow sensor
  - (2) Intake air temperature sensor
  - (3) Voltage (V)
  - (4) Intake air volume (kg/s)
- (A) Air

### 3. ENABLE CONDITION

Secondary Parameters	Enable Conditions
Battery voltage	$\geq 10.9 \text{ V}$

### 4. GENERAL DRIVING CYCLE

Always perform the diagnosis continuously.

### 5. DIAGNOSTIC METHOD

Judge NG when the continuous time of completing the malfunction criteria below becomes more than 0.5 seconds. Judge OK and clear the NG when the malfunction criteria below are not completed.

#### Judgment Value

Malfunction Criteria	Threshold Value
Output voltage	$\leq 0.2 \text{ V}$

**Time Needed for Diagnosis:** 0.5 seconds

**Malfunction Indicator Light Illumination:** Illuminates as soon as the malfunction occurs.

### 6. DTC CLEAR CONDITION

- When the OK idling cycle was completed 40 times in a row
- When "Clear Memory" was performed

### 7. MALFUNCTION INDICATOR LIGHT CLEAR CONDITION

- When the OK driving cycle was completed 3 times in a row
- When "Clear Memory" was performed



## Diagnostic Trouble Code (DTC) Detecting Criteria

### GENERAL DESCRIPTION

---

#### 8. FAIL SAFE

None

#### 9. ECM OPERATING AT DTC SETTING

Memorize the freeze frame data. (For test mode \$02)

# Diagnostic Trouble Code (DTC) Detecting Criteria

GENERAL DESCRIPTION

## I: DTC P0103 MASS OR VOLUME AIR FLOW CIRCUIT HIGH INPUT

### 1. OUTLINE OF DIAGNOSIS

Detect the open or short circuit of air flow sensor. Judge NG when out of the standard value.

### 2. COMPONENT DESCRIPTION

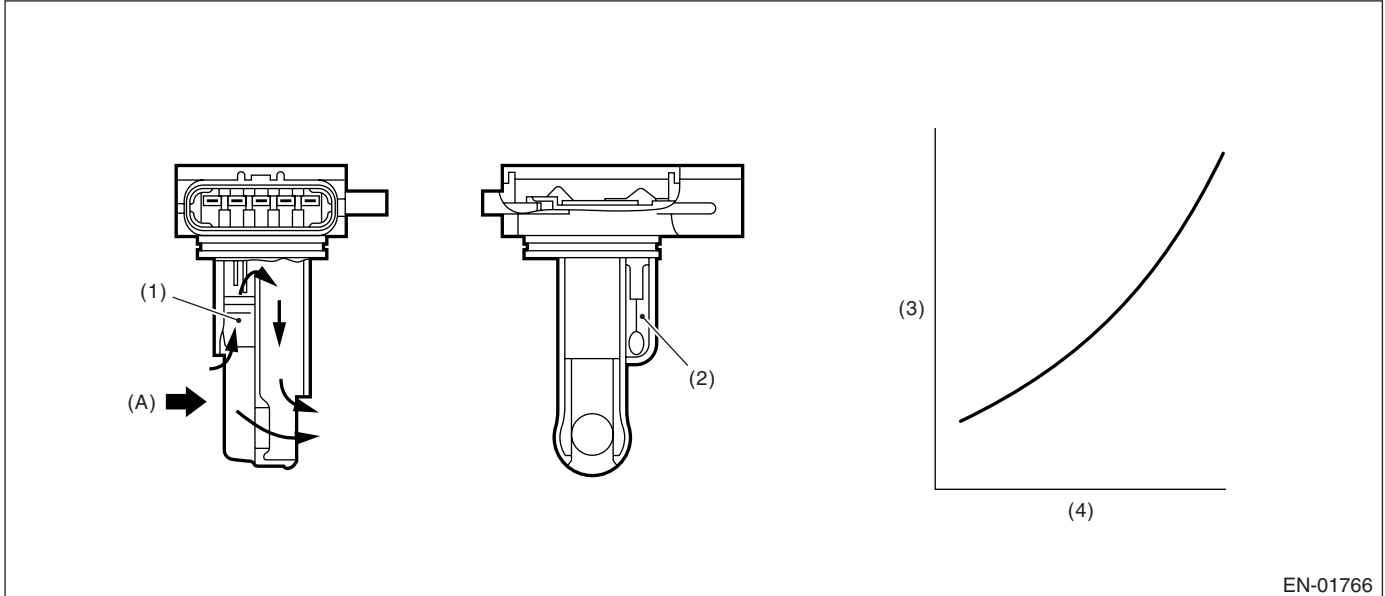

- (1) Air flow sensor
  - (2) Intake air temperature sensor
  - (3) Voltage (V)
  - (4) Intake air volume (kg/s)
- (A) Air

### 3. ENABLE CONDITION

Secondary Parameters	Enable Conditions
Battery voltage	$\geq 10.9 \text{ V}$

### 4. GENERAL DRIVING CYCLE

Always perform the diagnosis continuously.

### 5. DIAGNOSTIC METHOD

Judge NG when the continuous time until completing the malfunction criteria below becomes more than 0.5 seconds. Judge OK and clear the NG when the malfunction criteria below are not completed.

#### Judgment Value

Malfunction Criteria	Threshold Value
Output voltage	$\geq 4.71 \text{ V}$

**Time Needed for Diagnosis:** 0.5 seconds

**Malfunction Indicator Light Illumination:** Illuminates as soon as the malfunction occurs.

### 6. DTC CLEAR CONDITION

- When the OK idling cycle was completed 40 times in a row
- When "Clear Memory" was performed

### 7. MALFUNCTION INDICATOR LIGHT CLEAR CONDITION

- When the OK driving cycle was completed 3 times in a row
- When "Clear Memory" was performed

## Diagnostic Trouble Code (DTC) Detecting Criteria

### GENERAL DESCRIPTION

---

#### 8. FAIL SAFE

None

#### 9. ECM OPERATING AT DTC SETTING

Memorize the freeze frame data. (For test mode \$02)

# Diagnostic Trouble Code (DTC) Detecting Criteria

GENERAL DESCRIPTION

## J: DTC P0107 MANIFOLD ABSOLUTE PRESSURE/BAROMETRIC PRESSURE CIRCUIT LOW INPUT

### 1. OUTLINE OF DIAGNOSIS

Detect the open or short circuit of intake manifold pressure sensor. Judge NG when out of the standard value.

### 2. COMPONENT DESCRIPTION

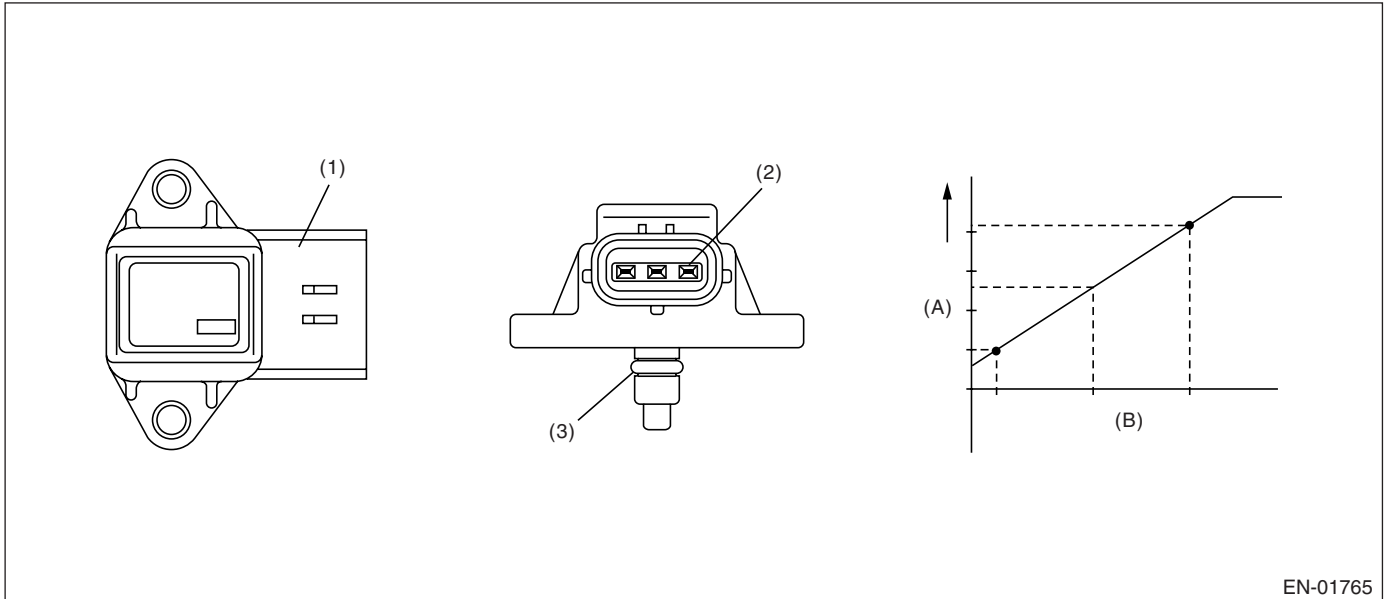

- (1) Connector
- (2) Terminal
- (3) O-ring

- (A) Output voltage
- (B) Absolute pressure

### 3. ENABLE CONDITION

Secondary Parameters	Enable Conditions
None	

### 4. GENERAL DRIVING CYCLE

Always perform the diagnosis continuously.

### 5. DIAGNOSTIC METHOD

Judge NG when the continuous time of completing the malfunction criteria below becomes more than 0.5 seconds. Judge OK and clear the NG when the malfunction criteria below are not completed.

#### Judgment Value

Malfunction Criteria	Threshold Value
Output voltage	< 0.7 V

**Time Needed for Diagnosis:** 0.5 seconds

**Malfunction Indicator Light Illumination:** Illuminates as soon as the malfunction occurs.

### 6. DTC CLEAR CONDITION

- When the OK idling cycle was completed 40 times in a row
- When "Clear Memory" was performed

## Diagnostic Trouble Code (DTC) Detecting Criteria

### GENERAL DESCRIPTION

---

#### 7. MALFUNCTION INDICATOR LIGHT CLEAR CONDITION

- When the OK driving cycle was completed 3 times in a row
- When "Clear Memory" was performed

#### 8. FAIL SAFE

- Intake manifold pressure sensor process: Estimate the pressure from engine load.
- ISC feedback: Not allowed to calculate the amount of feedback.
- Heavy fuel judgment: Not allowed to carry out the heavy judgment.

#### 9. ECM OPERATING AT DTC SETTING

Memorize the freeze frame data. (For test mode \$02)

# Diagnostic Trouble Code (DTC) Detecting Criteria

GENERAL DESCRIPTION

## K: DTC P0108 MANIFOLD ABSOLUTE PRESSURE/BAROMETRIC PRESSURE CIRCUIT HIGH INPUT

### 1. OUTLINE OF DIAGNOSIS

Detect the open or short circuit of intake manifold pressure sensor. Judge NG when out of the standard value.

### 2. COMPONENT DESCRIPTION

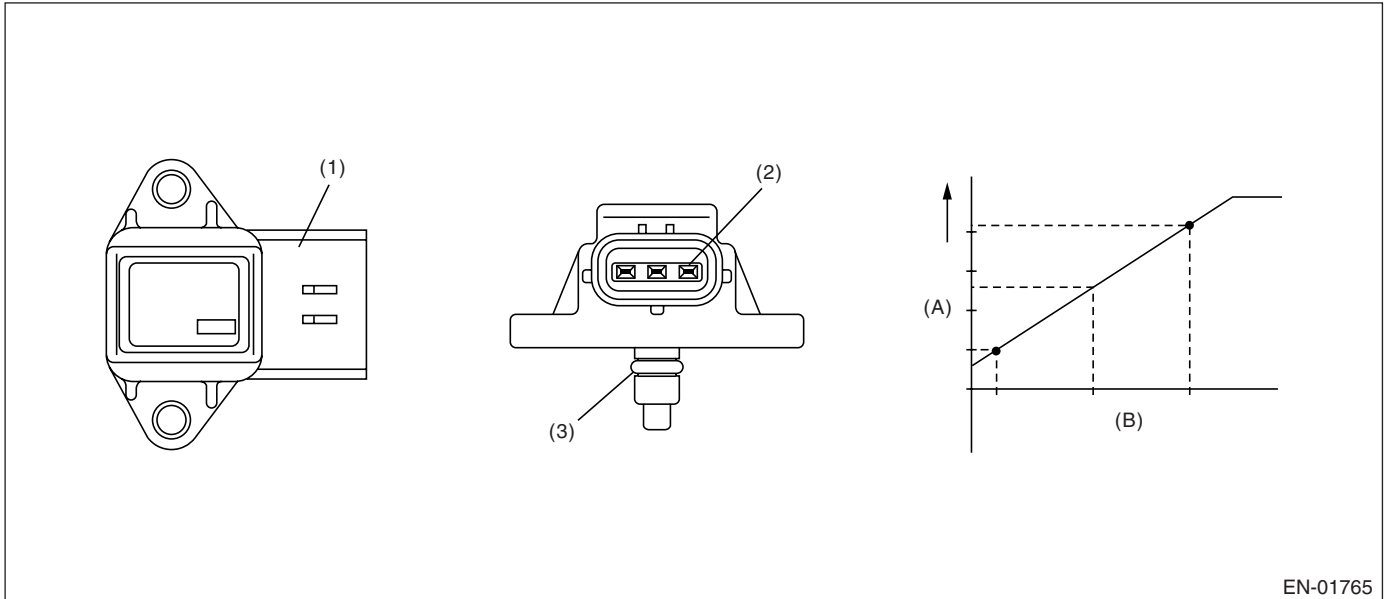

- (1) Connector
- (2) Terminal
- (3) O-ring

- (A) Output voltage
- (B) Absolute pressure

### 3. ENABLE CONDITION

Secondary Parameters	Enable Conditions
None	

### 4. GENERAL DRIVING CYCLE

Always perform the diagnosis continuously.

### 5. DIAGNOSTIC METHOD

Judge NG when the continuous time of completing the malfunction criteria below becomes more than 0.5 seconds. Judge OK and clear the NG when the malfunction criteria below are not completed.

#### Judgment Value

Malfunction Criteria	Threshold Value
Output voltage	$\geq 4.93$ V

**Time Needed for Diagnosis:** 0.5 seconds

**Malfunction Indicator Light Illumination:** Illuminates as soon as the malfunction occurs.

### 6. DTC CLEAR CONDITION

- When the OK idling cycle was completed 40 times in a row
- When "Clear Memory" was performed

## Diagnostic Trouble Code (DTC) Detecting Criteria

### GENERAL DESCRIPTION

---

#### 7. MALFUNCTION INDICATOR LIGHT CLEAR CONDITION

- When the OK driving cycle was completed 3 times in a row
- When "Clear Memory" was performed

#### 8. FAIL SAFE

- Intake manifold pressure sensor process: Estimate the pressure from engine load.
- ISC feedback: Not allowed to calculate the amount of feedback.
- Heavy fuel judgment: Not allowed to carry out the heavy judgment.

#### 9. ECM OPERATING AT DTC SETTING

Memorize the freeze frame data. (For test mode \$02)

# Diagnostic Trouble Code (DTC) Detecting Criteria

GENERAL DESCRIPTION

## L: DTC P0111 INTAKE AIR TEMPERATURE CIRCUIT RANGE/PERFORMANCE

### 1. OUTLINE OF DIAGNOSIS

Detect the malfunction of intake air temperature sensor output property. Judge NG when the intake air temperature is not varied whereas it seemed to be varied from the viewpoint of engine condition.

### 2. COMPONENT DESCRIPTION

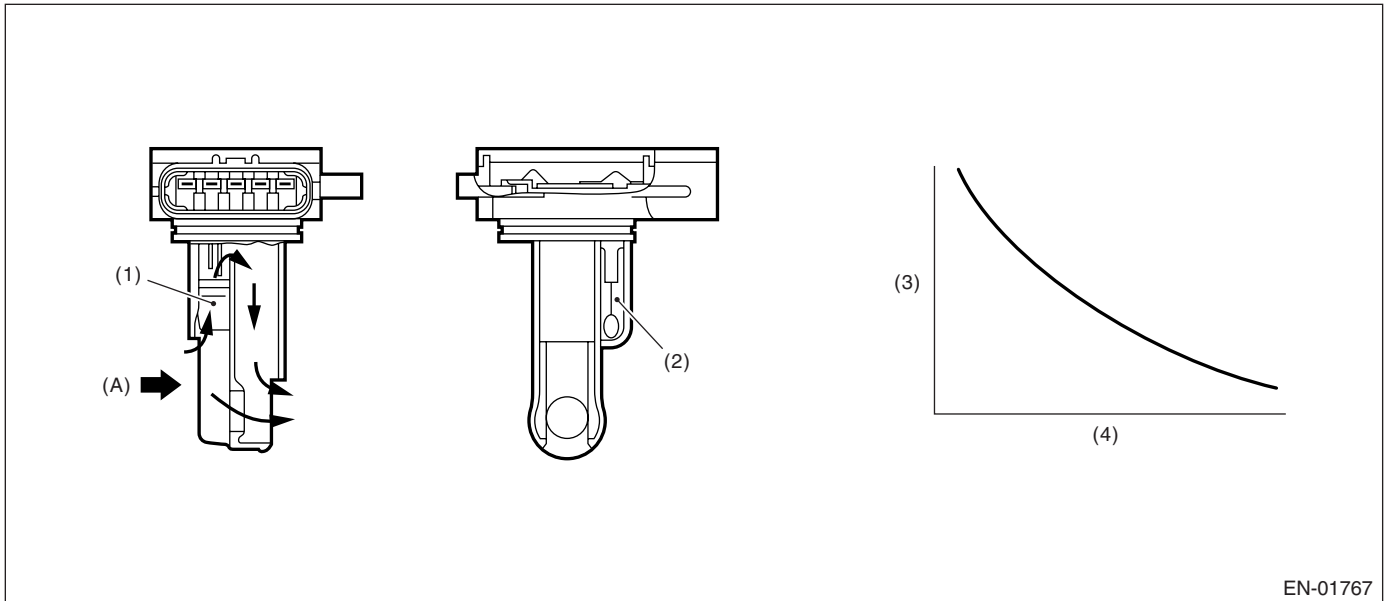

- (1) Air flow sensor
  - (2) Intake air temperature sensor
  - (3) Resistance ( $\Omega$ )
  - (4) Intake air temperature  $^{\circ}\text{C}$  ( $^{\circ}\text{F}$ )
- (A) Air

### 3. ENABLE CONDITION

Secondary Parameters	Enable Conditions
Coolant temp. before engine start	$< 30^{\circ}\text{C}$ ( $86^{\circ}\text{F}$ )
Coolant temperature	$> 75^{\circ}\text{C}$ ( $167^{\circ}\text{F}$ )
Battery voltage	$\geq 10.9\text{ V}$
Continuous time when the vehicle speed is less than 50 km/h (31 MPH)	600 seconds or more

### 4. GENERAL DRIVING CYCLE

Perform the diagnosis when the vehicle speed condition is completed after idling from starting the cooled engine.



# Diagnostic Trouble Code (DTC) Detecting Criteria

## GENERAL DESCRIPTION

### 5. DIAGNOSTIC METHOD

#### • Abnormality Judgment

Judge NG when the continuous time of completing the malfunction criteria below becomes more than 1 second.

#### Judgment Value

Malfunction Criteria	Threshold Value
Output voltage difference between Max. and Min.	< 20 mV (It is equal to approx. 0.5°C (33°F) around 25°.)
Exhaust temperature above 500°C (932°F)	60 seconds or more

**Time Needed for Diagnosis:** 1 second

**Malfunction Indicator Light Illumination:** Illuminates when malfunction occurs in 2 continuous driving cycles.

#### • Normality Judgment

Judge OK and clear the NG when the malfunction criteria below are completed.

#### Judgment Value

Malfunction Criteria	Threshold Value
Output voltage difference between Max. and Min.	≥ 20 mV

### 6. DTC CLEAR CONDITION

- When the OK idling cycle was completed 40 times in a row
- When "Clear Memory" was performed

### 7. MALFUNCTION INDICATOR LIGHT CLEAR CONDITION

- When the OK driving cycle was completed 3 times in a row
- When "Clear Memory" was performed

### 8. FAIL SAFE

Intake air temperature sensor process: Intake air temperature is fixed at 20°C (68°F).

### 9. ECM OPERATING AT DTC SETTING

Memorize the freeze frame data. (For test mode \$02)

# Diagnostic Trouble Code (DTC) Detecting Criteria

GENERAL DESCRIPTION

## M: DTC P0112 INTAKE AIR TEMPERATURE CIRCUIT LOW INPUT

### 1. OUTLINE OF DIAGNOSIS

Detect the open or short circuit of intake air temperature sensor. Judge NG when out of the standard value.

### 2. COMPONENT DESCRIPTION

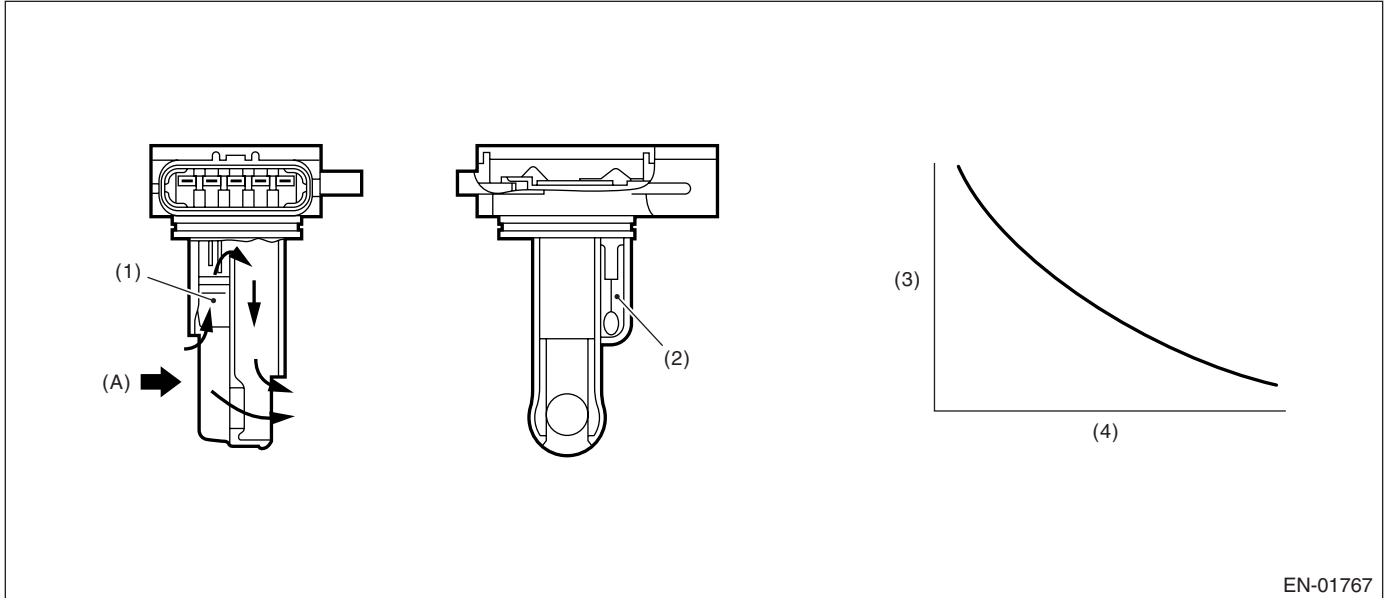

- (1) Air flow sensor
  - (2) Intake air temperature sensor
  - (3) Resistance ( $\Omega$ )
  - (4) Intake air temperature  $^{\circ}\text{C}$  ( $^{\circ}\text{F}$ )
- (A) Air

### 3. ENABLE CONDITION

Secondary Parameters	Enable Conditions
None	

### 4. GENERAL DRIVING CYCLE

Always perform the diagnosis continuously.

### 5. DIAGNOSTIC METHOD

#### • Abnormality Judgment

Judge NG when the continuous time of completing the malfunction criteria below becomes more than 0.5 seconds.

#### Judgment Value

Malfunction Criteria	Threshold Value
Output voltage	< 0.23 V
Ignition switch	ON

**Time Needed for Diagnosis:** 0.5 seconds

**Malfunction Indicator Light Illumination:** Illuminates as soon as the malfunction occurs.

# Diagnostic Trouble Code (DTC) Detecting Criteria

## GENERAL DESCRIPTION

---

### • Normality Judgment

Judge OK and clear the NG when the malfunction criteria below are completed.

### Judgment Value

Malfunction Criteria	Threshold Value
Output voltage	$\geq 0.23$ V
Ignition switch	ON

### 6. DTC CLEAR CONDITION

- When the OK idling cycle was completed 40 times in a row
- When "Clear Memory" was performed

### 7. MALFUNCTION INDICATOR LIGHT CLEAR CONDITION

- When the OK driving cycle was completed 3 times in a row
- When "Clear Memory" was performed

### 8. FAIL SAFE

Intake air temperature sensor process: Intake air temperature is fixed at 20°C (68°F).

### 9. ECM OPERATING AT DTC SETTING

Memorize the freeze frame data. (For test mode \$02)

# Diagnostic Trouble Code (DTC) Detecting Criteria

GENERAL DESCRIPTION

## N: DTC P0113 INTAKE AIR TEMPERATURE CIRCUIT HIGH INPUT

### 1. OUTLINE OF DIAGNOSIS

Detect the open or short circuit of intake air temperature sensor. Judge NG when out of the standard value.

### 2. COMPONENT DESCRIPTION

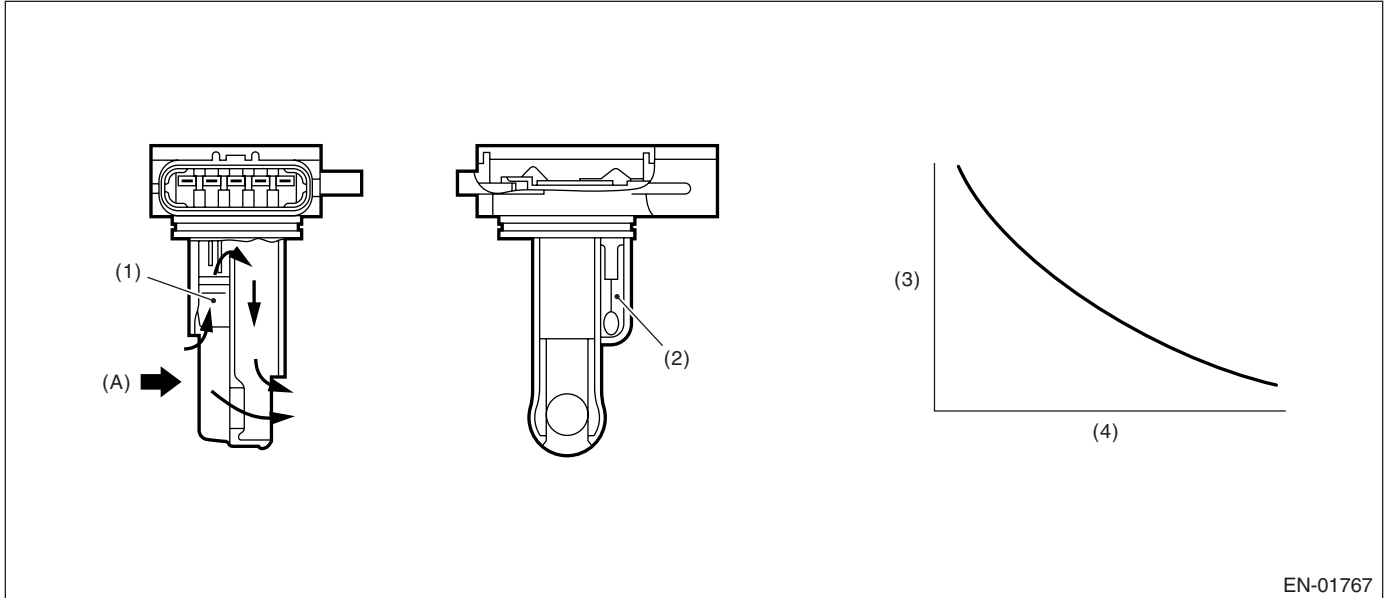

- (1) Air flow sensor
  - (2) Intake air temperature sensor
  - (3) Resistance ( $\Omega$ )
  - (4) Intake air temperature  $^{\circ}\text{C}$  ( $^{\circ}\text{F}$ )
- (A) Air

### 3. ENABLE CONDITION

Secondary Parameters	Enable Conditions
None	

### 4. GENERAL DRIVING CYCLE

Always perform the diagnosis continuously.

### 5. DIAGNOSTIC METHOD

#### • Abnormality Judgment

Judge NG when the continuous time of completing the malfunction criteria below becomes more than 0.5 seconds.

#### Judgment Value

Malfunction Criteria	Threshold Value
Output voltage	$\geq 4.72 \text{ V}$
Ignition switch	ON

**Time Needed for Diagnosis:** 0.5 seconds

**Malfunction Indicator Light Illumination:** Illuminates as soon as the malfunction occurs.

# Diagnostic Trouble Code (DTC) Detecting Criteria

## GENERAL DESCRIPTION

---

### • Normality Judgment

Judge OK and clear the NG when the malfunction criteria below are completed.

### Judgment Value

Malfunction Criteria	Threshold Value
Output voltage	$\geq 0.23$ V
Ignition switch	ON

### 6. DTC CLEAR CONDITION

- When the OK idling cycle was completed 40 times in a row
- When "Clear Memory" was performed

### 7. MALFUNCTION INDICATOR LIGHT CLEAR CONDITION

- When the OK driving cycle was completed 3 times in a row
- When "Clear Memory" was performed

### 8. FAIL SAFE

Intake air temperature sensor process: Intake air temperature is fixed at 20°C (68°F).

### 9. ECM OPERATING AT DTC SETTING

Memorize the freeze frame data. (For test mode \$02)

# Diagnostic Trouble Code (DTC) Detecting Criteria

GENERAL DESCRIPTION

## O: DTC P0117 ENGINE COOLANT TEMPERATURE CIRCUIT LOW INPUT

### 1. OUTLINE OF DIAGNOSIS

Detect the open or short circuit of engine coolant temperature sensor. Judge NG when out of the standard value.

### 2. COMPONENT DESCRIPTION

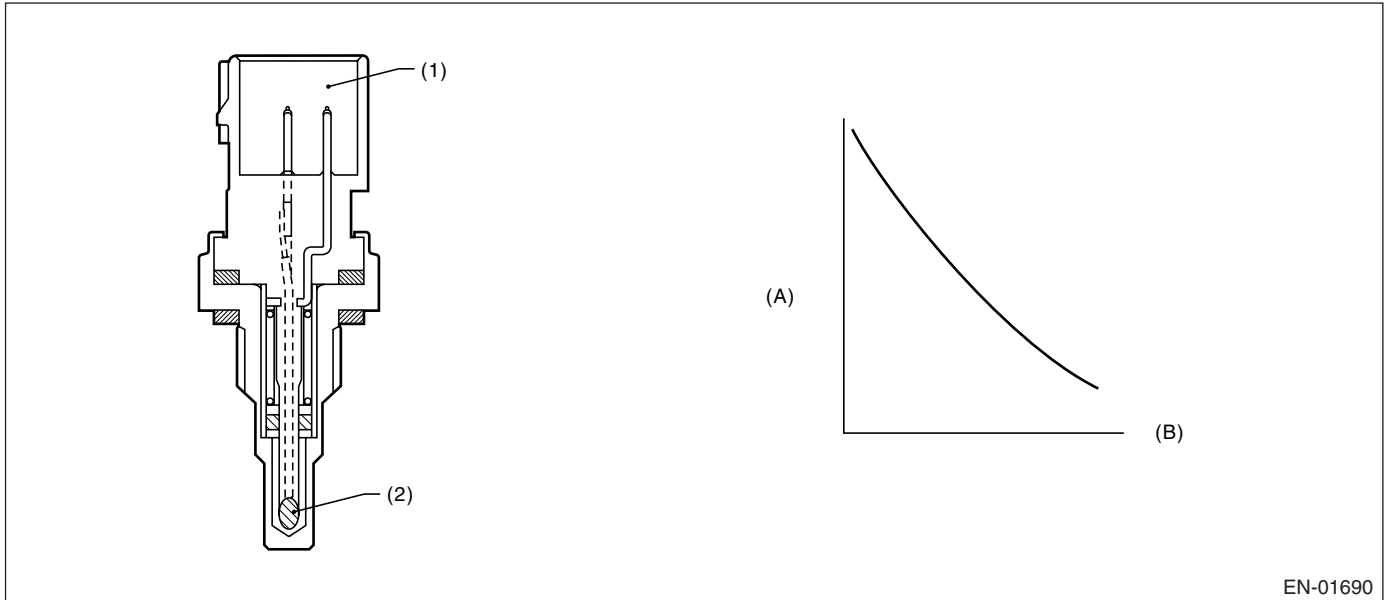

- (1) Connector
- (2) Thermistor element

- (A) Resistance value (kΩ)
- (B) Temperature °C (°F)

EN-01690

### 3. ENABLE CONDITION

Secondary Parameters	Enable Conditions
None	

### 4. GENERAL DRIVING CYCLE

Always perform the diagnosis continuously.

### 5. DIAGNOSTIC METHOD

Judge NG when the continuous time of completing the malfunction criteria below becomes more than 0.5 seconds. Judge OK and clear the NG when the malfunction criteria below are not completed.

#### Judgment Value

Malfunction Criteria	Threshold Value
Output voltage	< 0.23 V

**Time Needed for Diagnosis:** 0.5 seconds

**Malfunction Indicator Light Illumination:** Illuminates as soon as the malfunction occurs.

### 6. DTC CLEAR CONDITION

- When the OK idling cycle was completed 40 times in a row
- When "Clear Memory" was performed

### 7. MALFUNCTION INDICATOR LIGHT CLEAR CONDITION

- When the OK driving cycle was completed 3 times in a row
- When "Clear Memory" was performed

## Diagnostic Trouble Code (DTC) Detecting Criteria

### GENERAL DESCRIPTION

---

#### 8. FAIL SAFE

- Engine coolant temperature process: Fix the engine coolant temperature at 70°C (158°F).
- ISC feedback: Calculate the target engine speed setting the engine coolant temperature to 70°C (158°F).
- ISC learning: Not allowed to learn.
- Heavy fuel judgment control: Not allowed to carry out the heavy judgment.
- Air conditioner control: Not allowed to turn the air conditioner to ON.
- Radiator fan control: Both main and sub fan are in High driving.

#### 9. ECM OPERATING AT DTC SETTING

Memorize the freeze frame data. (For test mode \$02)

# Diagnostic Trouble Code (DTC) Detecting Criteria

GENERAL DESCRIPTION

## P: DTC P0118 ENGINE COOLANT TEMPERATURE CIRCUIT HIGH INPUT

### 1. OUTLINE OF DIAGNOSIS

Detect the open or short circuit of engine coolant temperature sensor. Judge NG when out of the standard value.

### 2. COMPONENT DESCRIPTION

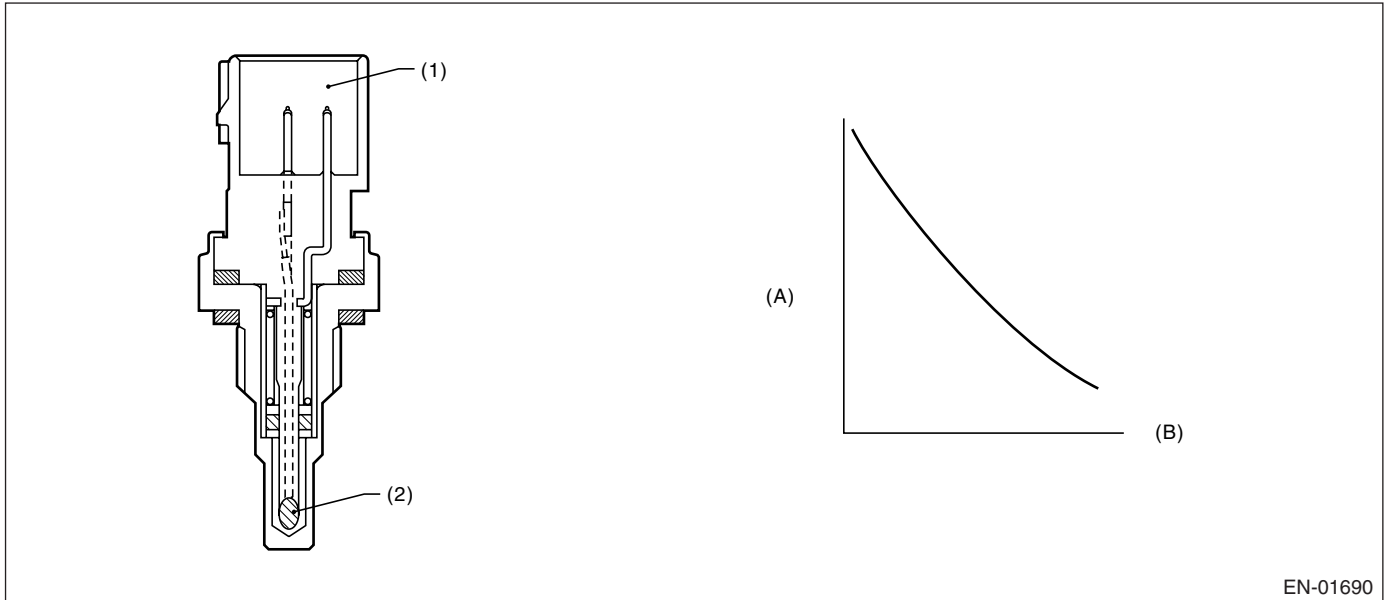

- (1) Connector
- (2) Thermistor element

- (A) Resistance value (kΩ)
- (B) Temperature °C (°F)

EN-01690

### 3. ENABLE CONDITION

Secondary Parameters	Enable Conditions
None	

### 4. GENERAL DRIVING CYCLE

Always perform the diagnosis continuously.

### 5. DIAGNOSTIC METHOD

Judge NG when the continuous time of completing the malfunction criteria below becomes more than 0.5 seconds. Judge OK and clear the NG when the malfunction criteria below are not completed.

#### Judgment Value

Malfunction Criteria	Threshold Value
Output voltage	$\geq 4.72$ V

**Time Needed for Diagnosis:** 0.5 seconds

**Malfunction Indicator Light Illumination:** Illuminates as soon as the malfunction occurs.

### 6. DTC CLEAR CONDITION

- When the OK idling cycle was completed 40 times in a row
- When "Clear Memory" was performed

### 7. MALFUNCTION INDICATOR LIGHT CLEAR CONDITION

- When the OK driving cycle was completed 3 times in a row
- When "Clear Memory" was performed



## Diagnostic Trouble Code (DTC) Detecting Criteria

### GENERAL DESCRIPTION

---

#### 8. FAIL SAFE

- Engine coolant temperature process: Fix the engine coolant temperature at 70°C (158°F).
- ISC feedback: Calculate the target engine speed setting the engine coolant temperature to 70°C (158°F).
- ISC learning: Not allowed to learn.
- Heavy fuel judgment control: Not allowed to carry out the heavy judgment.
- Air conditioner control: Not allowed to turn the air conditioner to ON.
- Radiator fan control: Both main and sub fan are in High driving.

#### 9. ECM OPERATING AT DTC SETTING

Memorize the freeze frame data. (For test mode \$02)

# Diagnostic Trouble Code (DTC) Detecting Criteria

GENERAL DESCRIPTION

## Q: DTC P0121 THROTTLE/PEDAL POSITION SENSOR/SWITCH "A" CIRCUIT RANGE/PERFORMANCE

### 1. OUTLINE OF DIAGNOSIS

Detect the malfunction of throttle position sensor output property. Judge NG when the throttle opening is largely different from the estimated value of throttle opening.

### 2. COMPONENT DESCRIPTION

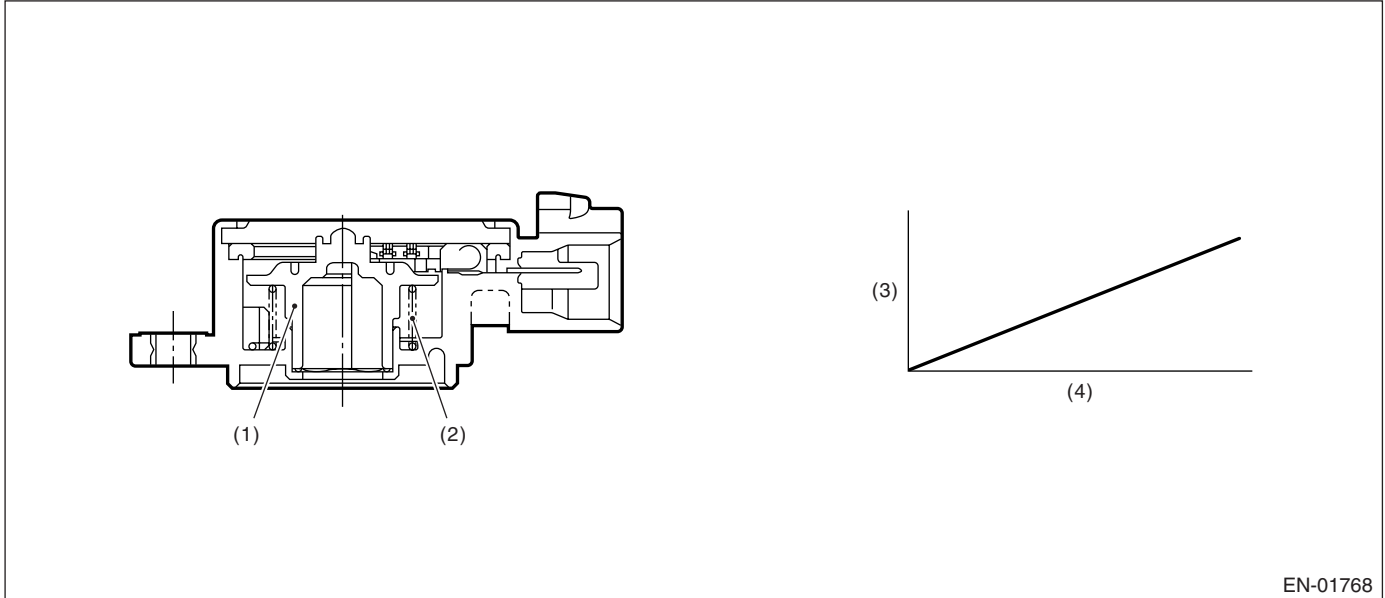

- (1) Rotor
- (2) Return spring
- (3) Voltage (V)
- (4) Throttle valve opening angle (°)

### 3. ENABLE CONDITION

Secondary Parameters	Enable Conditions
Engine coolant temperature	> 75°C (167°F)
Intake air temperature	> -10°C (14°F)
Atmospheric pressure	≥ 75.1 kPa (563 mmHg, 22.2 inHg)
Battery voltage	> 10.9 V
Fuel level	≥ 9 ℓ (2.38 US gal, 1.98 Imp gal)

### 4. GENERAL DRIVING CYCLE

Perform the diagnosis continuously after idling.

# Diagnostic Trouble Code (DTC) Detecting Criteria

## GENERAL DESCRIPTION

### 5. DIAGNOSTIC METHOD

#### • Abnormality Judgment

Judge NG when one of the malfunctions below is completed such as Low malfunction (1), Low malfunction (2) and High malfunction.

#### Judgment Value

Malfunction Criteria	Threshold Value
Low malfunction (1): Judge NG when the continuous time of completing the malfunction criteria below becomes more than 10 seconds. (Estimated value of throttle opening — output) throttle angle Engine speed Engine load (gn) Intake air change during 0.5 engine rev. Manifold absolute pressure	$\geq 20^\circ$ 1,000 $\leftrightarrow$ 3,200 rpm 0.2 $\leftrightarrow$ 1.0 g/rev $< 0.01$ g/rev $<$ Atmosphere -6.67 kPa (-50 mmHg, -1.97 inHg)
Low malfunction (2): Judge NG when the continuous time of completing the malfunction criteria below becomes more than 10 seconds $\times$ 6 times. Engine speed Engine load (gn) Throttle opening Elapsed time after engine starting	$\geq 1,600$ rpm $\geq 0.2$ g/rev $< 2^\circ$ $\geq 5$ seconds
High malfunction: Judge NG when the continuous time of completing the malfunction criteria below becomes more than 10 seconds. (Output — estimated value of throttle opening) throttle angle Engine speed Engine load (gn) Intake air change during 0.5 engine rev. Manifold absolute pressure	$\geq 20^\circ$ 1,000 $\leftrightarrow$ 3,200 rpm 0.2 $\leftrightarrow$ 1.0 g/rev $< 0.01$ g/rev $<$ Atmosphere -6.67 kPa (-50 mmHg, -1.97 inHg)

Estimated value of throttle opening: It is supposed from engine speed and engine load.

#### Time Needed for Diagnosis:

Low malfunction (1),	10 seconds
High malfunction	
Low malfunction (2)	10 seconds $\times$ 6 times.

**Malfunction Indicator Light Illumination:** Illuminates when malfunction occurs in 2 continuous driving cycles.

# Diagnostic Trouble Code (DTC) Detecting Criteria

GENERAL DESCRIPTION

## • Normality Judgment

Judge OK and clear the NG when all of the malfunctions below are not completed such as Low malfunction (1), Low malfunction (2) and High malfunction.

### Judgment Value

Malfunction Criteria	Threshold Value
Low malfunction (1): Judge OK when the continuous time of completing the malfunction criteria below becomes more than 3 seconds. (Estimated value of throttle opening — output) throttle angle Engine speed Engine load (gn) Intake air change during 0.5 engine rev. Manifold absolute pressure	< 20° 1,000 ↔ 3,200 rpm 0.2 ↔ 1.0 g/rev < 0.01 g/rev < Atmosphere -6.67 kPa (-50 mmHg, -1.97 inHg)
Low malfunction (2): Judge OK when the malfunction criteria below are completed. Throttle opening Elapsed time after engine starting	≥ 2° ≥ 5 seconds
High malfunction: Judge OK when the continuous time of completing the malfunction criteria below becomes more than 3 seconds. (Output — estimated value of throttle opening) throttle angle Engine speed Engine load (gn) Intake air change during 0.5 engine rev. Manifold absolute pressure	< 20° 1,000 ↔ 3,200 rpm 0.2 ↔ 1.0 g/rev < 0.01 g/rev < Atmosphere -6.67 kPa (-50 mmHg, -1.97 inHg)

## 6. DTC CLEAR CONDITION

- When the OK idling cycle was completed 40 times in a row
- When “Clear Memory” was performed

## 7. MALFUNCTION INDICATOR LIGHT CLEAR CONDITION

- When the OK driving cycle was completed 3 times in a row
- When “Clear Memory” was performed

## 8. FAIL SAFE

- Throttle position sensor process: Fix the throttle opening at 6.4°.
- ISC open loop compensation: Fix the amount of ISC open loop compensation at 5%.
- ISC feedback compensation: Not allowed to calculate the amount of ISC feedback compensation.

## 9. ECM OPERATING AT DTC SETTING

Memorize the freeze frame data. (For test mode \$02)

# Diagnostic Trouble Code (DTC) Detecting Criteria

## GENERAL DESCRIPTION

### R: DTC P0122 THROTTLE/PEDAL POSITION SENSOR/SWITCH "A" CIRCUIT LOW INPUT

#### 1. OUTLINE OF DIAGNOSIS

Detect the open or short circuit of throttle sensor.  
Judge NG when out of the standard value.

#### 2. COMPONENT DESCRIPTION

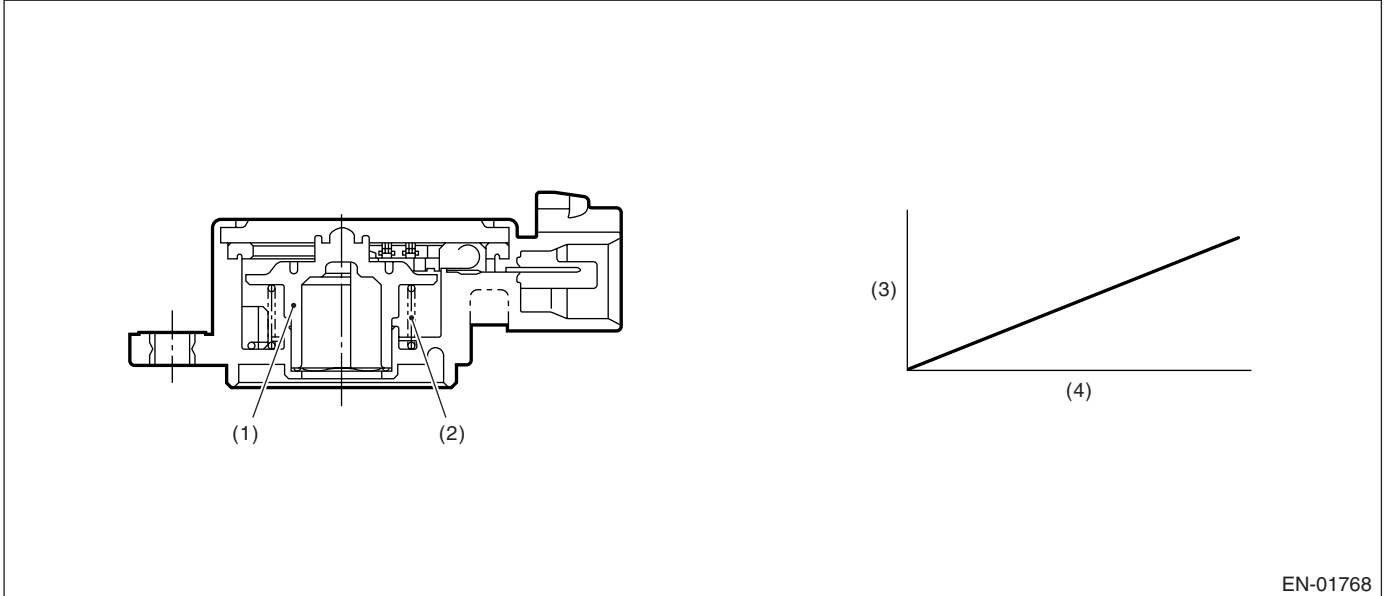

- (1) Rotor
- (2) Return spring
- (3) Voltage (V)
- (4) Throttle valve opening angle (°)

#### 3. ENABLE CONDITION

Secondary Parameters	Enable Conditions
None	

#### 4. GENERAL DRIVING CYCLE

Always perform the diagnosis continuously.

#### 5. DIAGNOSTIC METHOD

##### • Abnormality Judgment

Judge NG when the continuous time of completing the malfunction criteria below becomes more than 0.5 seconds.

##### Judgment Value

Malfunction Criteria	Threshold Value
Output voltage	< 0.15 V
Ignition switch	ON

**Time Needed for Diagnosis:** 0.5 seconds

**Malfunction Indicator Light Illumination:** Illuminates as soon as the malfunction occurs.

# Diagnostic Trouble Code (DTC) Detecting Criteria

GENERAL DESCRIPTION

## • Normality Judgment

Judge OK and clear the NG when the malfunction criteria below are completed.

### Judgment Value

Malfunction Criteria	Threshold Value
Output voltage	$\geq 0.15$ V
Ignition switch	ON

## 6. DTC CLEAR CONDITION

- When the OK idling cycle was completed 40 times in a row
- When "Clear Memory" was performed

## 7. MALFUNCTION INDICATOR LIGHT CLEAR CONDITION

- When the OK driving cycle was completed 3 times in a row
- When "Clear Memory" was performed

## 8. FAIL SAFE

- Throttle position sensor process: Fix the throttle opening at 6.4°.
- ISC open loop compensation: Fix the amount of ISC open loop compensation at 5%.
- ISC feedback compensation: Not allowed to calculate the amount of ISC feedback compensation.

## 9. ECM OPERATING AT DTC SETTING

Memorize the freeze frame data. (For test mode \$02)

# Diagnostic Trouble Code (DTC) Detecting Criteria

## GENERAL DESCRIPTION

### S: DTC P0123 THROTTLE/PEDAL POSITION SENSOR/SWITCH "A" CIRCUIT HIGH INPUT

#### 1. OUTLINE OF DIAGNOSIS

Detect the open or short circuit of throttle sensor.  
Judge NG when out of the standard value.

#### 2. COMPONENT DESCRIPTION

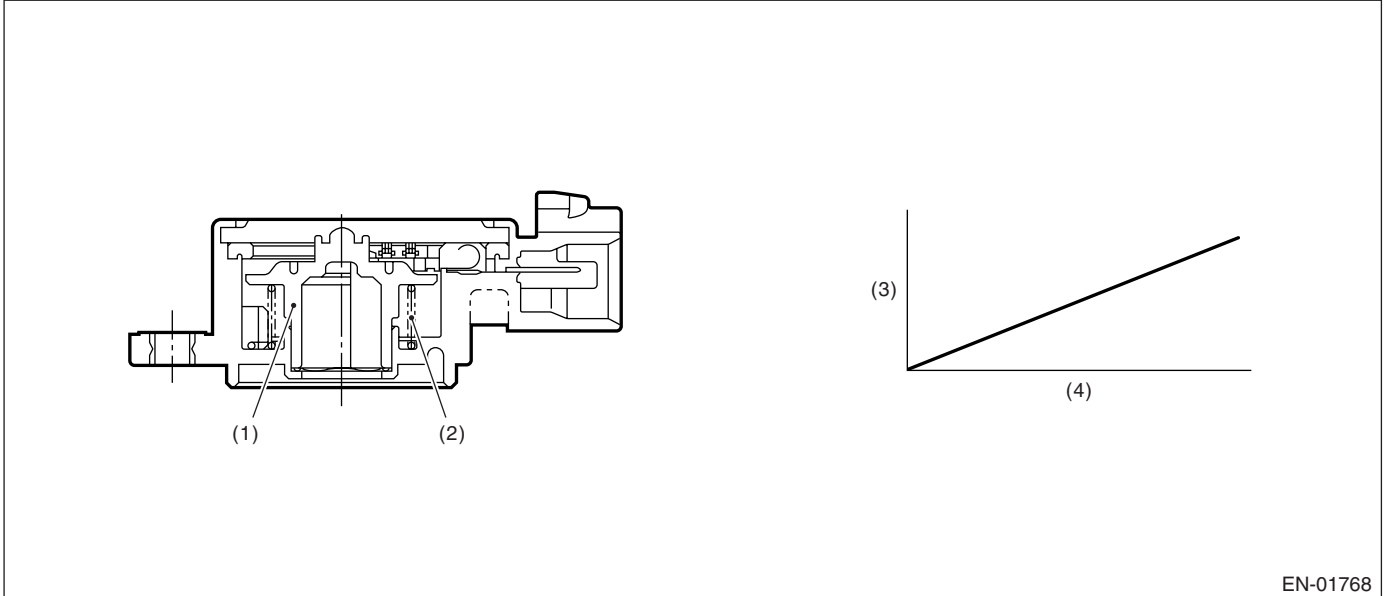

- (1) Rotor
- (2) Return spring
- (3) Voltage (V)
- (4) Throttle valve opening angle (°)

#### 3. ENABLE CONDITION

Secondary Parameters	Enable Conditions
None	

#### 4. GENERAL DRIVING CYCLE

Always perform the diagnosis continuously.

#### 5. DIAGNOSTIC METHOD

##### • Abnormality Judgment

Judge NG when the continuous time of completing the malfunction criteria below becomes more than 0.5 seconds.

##### Judgment Value

Malfunction Criteria	Threshold Value
Output voltage	$\geq 4.71$ V
Ignition switch	ON

**Time Needed for Diagnosis:** 0.5 seconds

**Malfunction Indicator Light Illumination:** Illuminates as soon as the malfunction occurs.

# Diagnostic Trouble Code (DTC) Detecting Criteria

GENERAL DESCRIPTION

## • Normality Judgment

Judge OK and clear the NG when the malfunction criteria below are completed.

### Judgment Value

Malfunction Criteria	Threshold Value
Output voltage	< 4.71 V
Ignition switch	ON

## 6. DTC CLEAR CONDITION

- When the OK idling cycle was completed 40 times in a row
- When "Clear Memory" was performed

## 7. MALFUNCTION INDICATOR LIGHT CLEAR CONDITION

- When the OK driving cycle was completed 3 times in a row
- When "Clear Memory" was performed

## 8. FAIL SAFE

- Throttle position sensor process: Fix the throttle opening at 6.4°.
- ISC open loop compensation: Fix the amount of ISC open loop compensation at 5%.
- ISC feedback compensation: Not allowed to calculate the amount of ISC feedback compensation.

## 9. ECM OPERATING AT DTC SETTING

Memorize the freeze frame data. (For test mode \$02)



# Diagnostic Trouble Code (DTC) Detecting Criteria

## GENERAL DESCRIPTION

### T: DTC P0125 INSUFFICIENT COOLANT TEMPERATURE FOR CLOSED LOOP FUEL CONTROL

#### 1. OUTLINE OF DIAGNOSIS

Detect the malfunction of engine coolant temperature output property. Judge NG when the engine coolant temperature does not rise whereas it seemed to rise from the viewpoint of the engine condition.

#### 2. COMPONENT DESCRIPTION

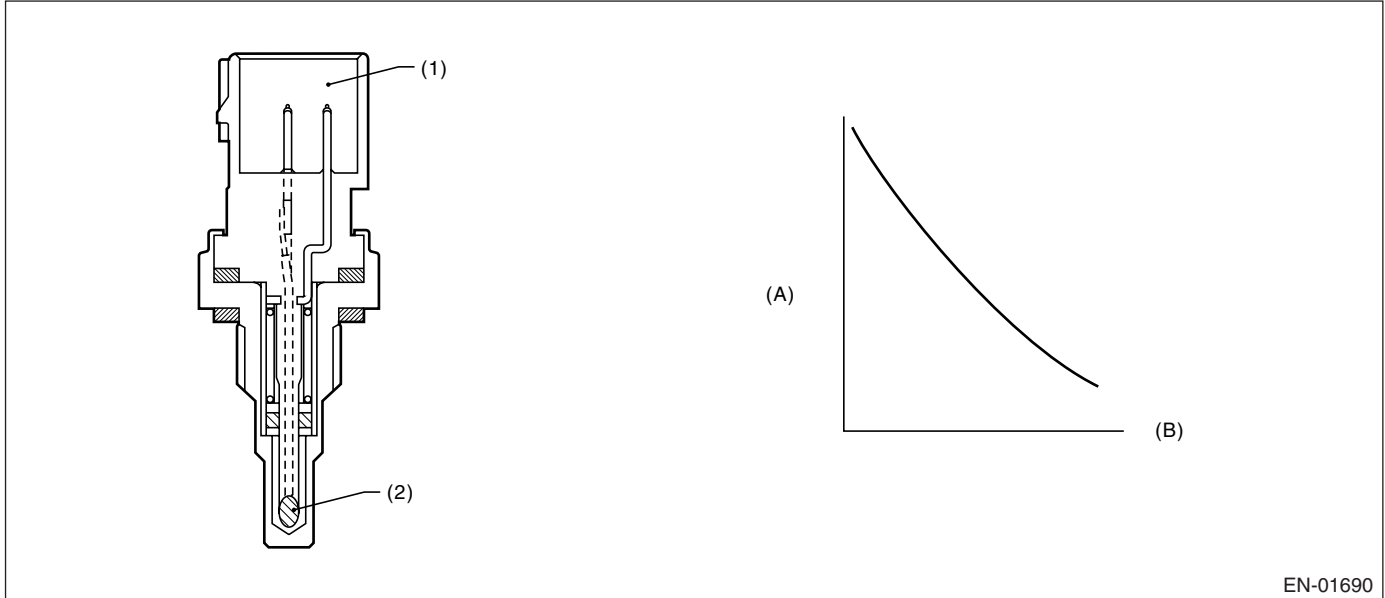

- (1) Connector
- (2) Thermistor element

- (A) Resistance value (kΩ)
- (B) Temperature °C (°F)

EN-01690

#### 3. ENABLE CONDITION

Secondary Parameters	Enable Conditions
Diagnosis of engine coolant temperature sensor property	Not finished
Engine speed	≥ 500 rpm
Battery voltage	> 10.9 V

#### 4. GENERAL DRIVING CYCLE

Perform the diagnosis only once after engine starting.

#### 5. DIAGNOSTIC METHOD

##### • Abnormality Judgment

Judge NG when the malfunction criteria below are completed.

##### Judgment Value

Malfunction Criteria	Threshold Value
Engine coolant temperature	< 20°C (68°F)
Timer for diagnosis after engine starting	≥ Timer judgment value after engine starting

Timer for diagnosis after engine starting

- a) Timer stop at fuel cut mode.
- b) During the driving conditions except a) above, timer count up by 65.5 milliseconds + TWCNT milliseconds at every 65.5 milliseconds.

# Diagnostic Trouble Code (DTC) Detecting Criteria

GENERAL DESCRIPTION

Where, TWCNT is determined as follows,  
TWCNT = 0 at idle switch ON,  
TWCNT show on the following table at idle switch OFF.

Temp. °C (°F)	Vehicle speed km/h (MPH)							
	0 (0)	8 (4.97)	16 (9.94)	24 (14.9)	32 (19.9)	40 (24.9)	48 (29.8)	56 (34.8)
-20 (-4)	0 ms	1.67 ms	3.33 ms	5.00 ms	13.11 ms	10.00 ms	19.66 ms	26.21 ms
-10 (14)	0 ms	13.11 ms	19.66 ms	32.77 ms	52.43 ms	72.09 ms	58.98 ms	45.88 ms
0 (32)	0 ms	18.24 ms	45.88 ms	72.09 ms	111.41 ms	150.73 ms	131.07 ms	104.86 ms
10 (50)	0 ms	39.32 ms	85.2 ms	124.52 ms	190.05 ms	229.38 ms	229.38 ms	183.50 ms

Judgment value of timer after engine starting

$$t = 429.5 - 6.685 \times T_i$$

$T_i$  is the lowest coolant temperature after starting the engine.

**Time Needed for Diagnosis:** To be determined. (It is varied by the Min. engine coolant temperature and engine conditions such as vehicle speed and engine coolant temperature.)

**Malfunction Indicator Light Illumination:** Illuminates when malfunction occurs in 2 continuous driving cycles.

## • Normality Judgment

Judge OK and clear the NG when the malfunction criteria below are completed.

### Judgment Value

Malfunction Criteria	Threshold Value
Engine coolant temperature	$\geq 20^\circ\text{C}$ (68°F)

## 6. DTC CLEAR CONDITION

- When the OK idling cycle was completed 40 times in a row
- When "Clear Memory" was performed

## 7. MALFUNCTION INDICATOR LIGHT CLEAR CONDITION

- When the OK driving cycle was completed 3 times in a row
- When "Clear Memory" was performed

## 8. FAIL SAFE

- Engine coolant temperature process: Fix the engine coolant temperature at 70°C (158°F).
- ISC feedback: Calculate the target engine speed setting the engine coolant temperature to 70°C (158°F).
- ISC learning: Not allowed to learn.
- Heavy fuel judgment control: Not allowed to carry out the heavy judgment.
- Air conditioner control: Not allowed to turn the air conditioner to ON.
- Radiator fan control: Both main and sub fan are in High driving.

## 9. ECM OPERATING AT DTC SETTING

Memorize the freeze frame data. (For test mode \$02)

# Diagnostic Trouble Code (DTC) Detecting Criteria

## GENERAL DESCRIPTION

### U: DTC P0128 COOLANT THERMOSTAT (COOLANT TEMPERATURE BELOW THERMOSTAT REGULATING TEMPERATURE)

#### 1. OUTLINE OF DIAGNOSIS

Detect the malfunction of thermostat function. Judge NG when the engine coolant temperature is lower than the estimated engine coolant temperature and the difference between them is large. Judge OK when the engine coolant temperature becomes 75°C (167°F) and the difference is small before judging NG.

#### 2. COMPONENT DESCRIPTION

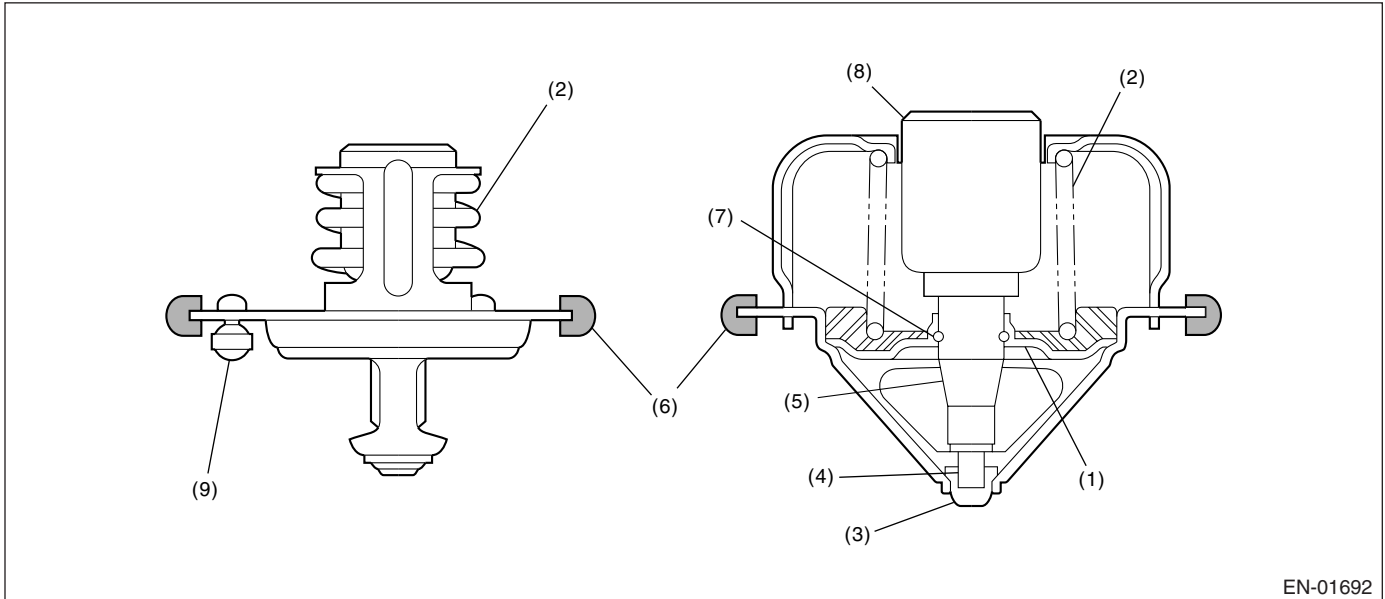

- (1) Valve
- (2) Spring
- (3) Stopper
- (4) Piston
- (5) Guide

- (6) Rubber packing
- (7) Stop ring
- (8) Wax element
- (9) Jiggle valve

#### 3. ENABLE CONDITION

Secondary Parameters	Enable Conditions
None	

#### 4. GENERAL DRIVING CYCLE

Always perform the diagnosis continuously.

# Diagnostic Trouble Code (DTC) Detecting Criteria

GENERAL DESCRIPTION

## 5. DIAGNOSTIC METHOD

### • Abnormality Judgment

Judge NG when the continuous time of completing the malfunction criteria below becomes more than 30 seconds.

### Judgment Value

Malfunction Criteria	Threshold Value
Battery voltage	$\geq 10.9$ V
Estimated ambient air temperature	$\geq -7^{\circ}\text{C}$ (19.4°F)
Thermostat malfunction diagnosis	Not finished
Engine coolant temperature at engine starting	$< 55^{\circ}\text{C}$ (131°F)
Estimated coolant temperature	$\geq 75^{\circ}\text{C}$ (167°F)
Engine coolant temperature	$< 75^{\circ}\text{C}$ (167°F)
(Estimated – measured) coolant temperature	$> 20^{\circ}\text{C}$ (68°F)

**Time Needed for Diagnosis:** 30 seconds

**Malfunction Indicator Light Illumination:** Illuminates when malfunction occurs in 2 continuous driving cycles.

### • Normality Judgment

Judge OK and clear the NG when the malfunction criteria below are completed.

### Judgment Value

Malfunction Criteria	Threshold Value
Battery voltage	$\geq 10.9$ V
Estimated ambient air temperature	$\geq -7^{\circ}\text{C}$ (19.4°F)
Thermostat malfunction diagnosis	Not finished
Engine coolant temperature at engine starting	$< 55^{\circ}\text{C}$ (131°F)
Engine coolant temperature	$\geq 75^{\circ}\text{C}$ (167°F)
(Estimated – measured) coolant temperature	$\leq 20^{\circ}\text{C}$ (68°F)

## 6. DTC CLEAR CONDITION

- When the OK idling cycle was completed 40 times in a row
- When “Clear Memory” was performed

## 7. MALFUNCTION INDICATOR LIGHT CLEAR CONDITION

- When the OK driving cycle was completed 3 times in a row
- When “Clear Memory” was performed

## 8. FAIL SAFE

None

## 9. ECM OPERATING AT DTC SETTING

- Memorize the freeze frame data. (For test mode \$02)
- Memorize the diagnostic value and trouble standard value. (For test mode \$06)

# Diagnostic Trouble Code (DTC) Detecting Criteria

## GENERAL DESCRIPTION

### V: DTC P0129 BAROMETRIC PRESSURE TOO LOW

#### 1. OUTLINE OF DIAGNOSIS

Detect the malfunction of atmospheric pressure sensor output property. Judge NG when the atmospheric pressure sensor output is largely different from the intake manifold pressure at engine starting.

#### 2. COMPONENT DESCRIPTION

Atmospheric pressure sensor is built in ECM.

#### 3. ENABLE CONDITION

Secondary Parameters	Enable Conditions
Engine speed at engine starting	< 300 rpm
Vehicle speed	< 1 km/h (0.62 MPH)
Diagnosis for atmospheric pressure sensor property	Not finished

#### 4. GENERAL DRIVING CYCLE

Perform the diagnosis once turning the ignition switch to ON.

#### 5. DIAGNOSTIC METHOD

##### • Abnormality Judgment

Judge NG when the continuous time of completing the malfunction criteria below becomes more than 0.33 seconds.

##### Judgment Value

Malfunction Criteria	Threshold Value
Atmospheric – manifold absolute pressure	≥ 26.7 kPa (200 mmHg, 7.88 inHg)
Intake manifold pressure at engine starting – manifold absolute pressure	< 1.33 kPa (10 mmHg, 2.95 inHg)

**Time Needed for Diagnosis:** 0.33 seconds

**Malfunction Indicator Light Illumination:** Detect when malfunction occurs in 2 continuous driving cycles.

##### • Normality Judgment

Judge OK and clear the NG when the continuous time of completing the malfunction criteria below becomes more than 0.26 seconds.

##### Judgment Value

Malfunction Criteria	Threshold Value
Atmospheric – manifold absolute pressure	< 26.7 kPa (200 mmHg, 7.88 inHg)

#### 6. DTC CLEAR CONDITION

- When the OK idling cycle was completed 40 times in a row
- When "Clear Memory" was performed

#### 7. MALFUNCTION INDICATOR LIGHT CLEAR CONDITION

- When the OK driving cycle was completed 3 times in a row
- When "Clear Memory" was performed

#### 8. FAIL SAFE

Atmospheric pressure sensor process: Fix the atmospheric pressure to 101 kPa (760 mmHg, 29.8 inHg).

#### 9. ECM OPERATING AT DTC SETTING

Memorize the freeze frame data. (For test mode \$02)

# Diagnostic Trouble Code (DTC) Detecting Criteria

GENERAL DESCRIPTION

## W: DTC P0130 O<sub>2</sub> SENSOR CIRCUIT (BANK 1 SENSOR 1)

### 1. OUTLINE OF DIAGNOSIS

Detect the short circuit of front oxygen (A/F) sensor heater. Diagnosis is performed using front oxygen (A/F) sensor IC, and communication is established between front oxygen (A/F) sensor IC and main IC. Front oxygen (A/F) sensor judges NG when the data of voltage (AFC, AFV) is abnormal.

### 2. COMPONENT DESCRIPTION

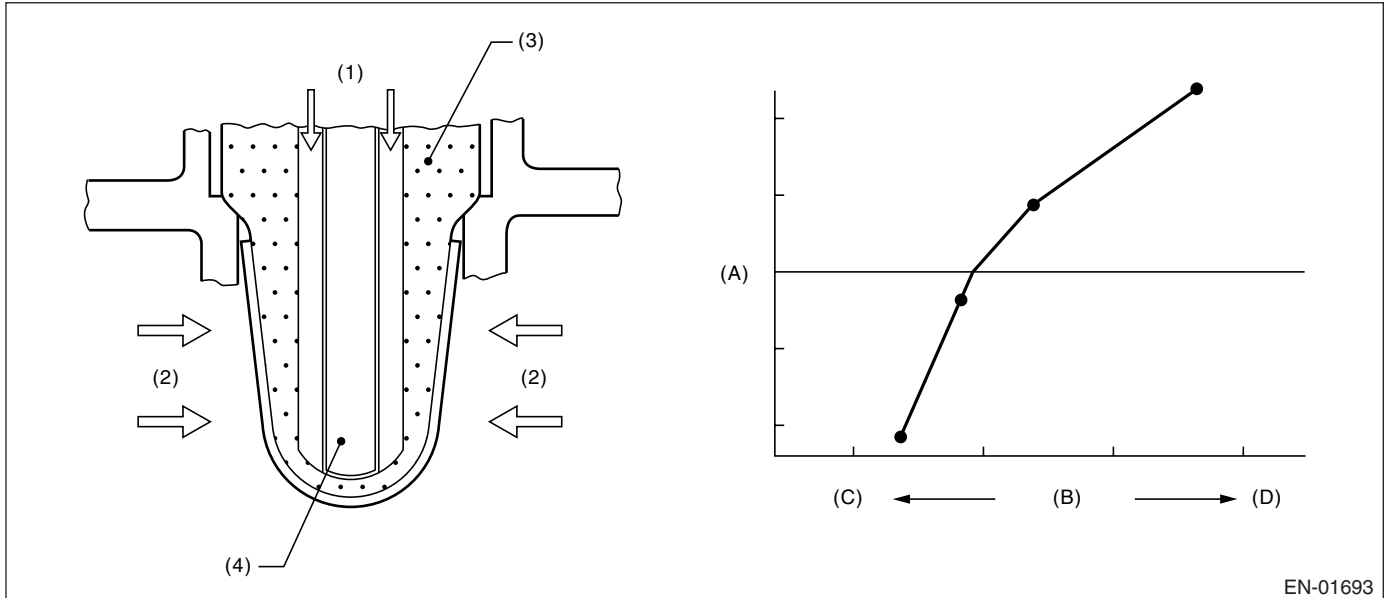

- (1) Atmosphere
- (2) Exhaust
- (3) ZrO<sub>2</sub>
- (4) Ceramic heater

- (A) Electromotive force
- (B) Air fuel ratio
- (C) Lean
- (D) Rich

### 3. ENABLE CONDITION

Secondary Parameters	Enable Conditions
None	

### 4. GENERAL DRIVING CYCLE

Always perform the diagnosis continuously.

### 5. DIAGNOSTIC METHOD

Front oxygen (A/F) sensor judges NG when the continuous time of completing the malfunction criteria below becomes more than the time needed for diagnosis (4.6 seconds). Front oxygen (A/F) sensor judges OK and clear NG when the malfunction criteria below are not completed.

#### Judgment Value

Malfunction Criteria	Threshold Value
Output voltage	(Battery voltage short) AFC > 4.5 V or AFV > 4.95 V (Ground short) AFC < 3.5 V or AFV < 2.5 V

**Time Needed for Diagnosis:** 4.6 seconds

**Malfunction Indicator Light Illumination:** Illuminates as soon as the malfunction occurs.

## Diagnostic Trouble Code (DTC) Detecting Criteria

### GENERAL DESCRIPTION

---

#### 6. DTC CLEAR CONDITION

- When the OK idling cycle was completed 40 times in a row
- When "Clear Memory" was performed

#### 7. MALFUNCTION INDICATOR LIGHT CLEAR CONDITION

- When the OK driving cycle was completed 3 times in a row
- When "Clear Memory" was performed

#### 8. FAIL SAFE

- Front oxygen (A/F) sensor IC communication: Not allowed to communicate
- Front oxygen (A/F) sensor main learning correction: Not allowed to calculate
- Correction when re-starting at high temperature: Normally minimum value 0.3 → 0
- Purge control: Not allowed to purge

#### 9. ECM OPERATING AT DTC SETTING

Memorize the freeze frame data. (For test mode \$02)

# Diagnostic Trouble Code (DTC) Detecting Criteria

GENERAL DESCRIPTION

## X: DTC P0133 O<sub>2</sub> SENSOR CIRCUIT SLOW RESPONSE (BANK 1 SENSOR 1)

### 1. OUTLINE OF DIAGNOSIS

Detect time-lag of front oxygen (A/F) sensor response. Front oxygen (A/F) sensor cover has some ventilation holes for exhaust gas. Clogged ventilation holes are diagnosed. When the holes are clogged, the A/F output variation becomes slow comparing with the actual A/F variation because oxygen which reaches the zirconia layer is insufficient. Therefore, if the cover has clogged holes, the rich to lean judgment in ECM is delayed when the change from rich to lean is caused.

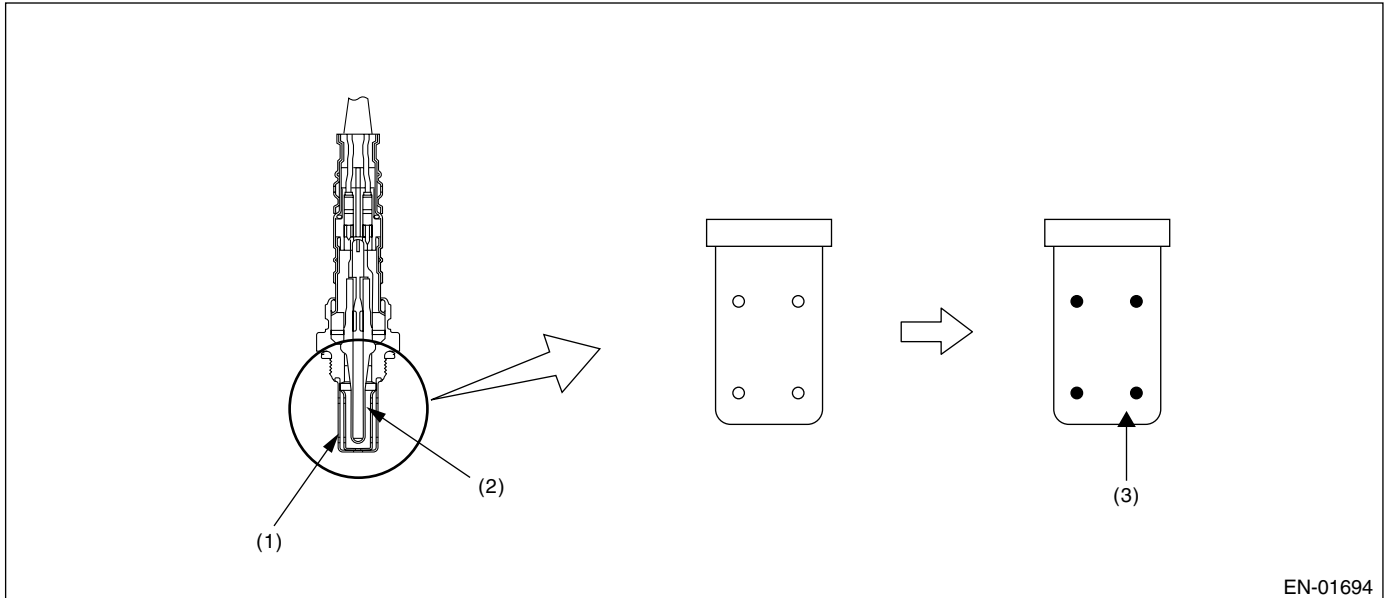

EN-01694

- (1) Cover
- (2) Zirconia
- (3) Clogging



# Diagnostic Trouble Code (DTC) Detecting Criteria

## GENERAL DESCRIPTION

### 2. COMPONENT DESCRIPTION

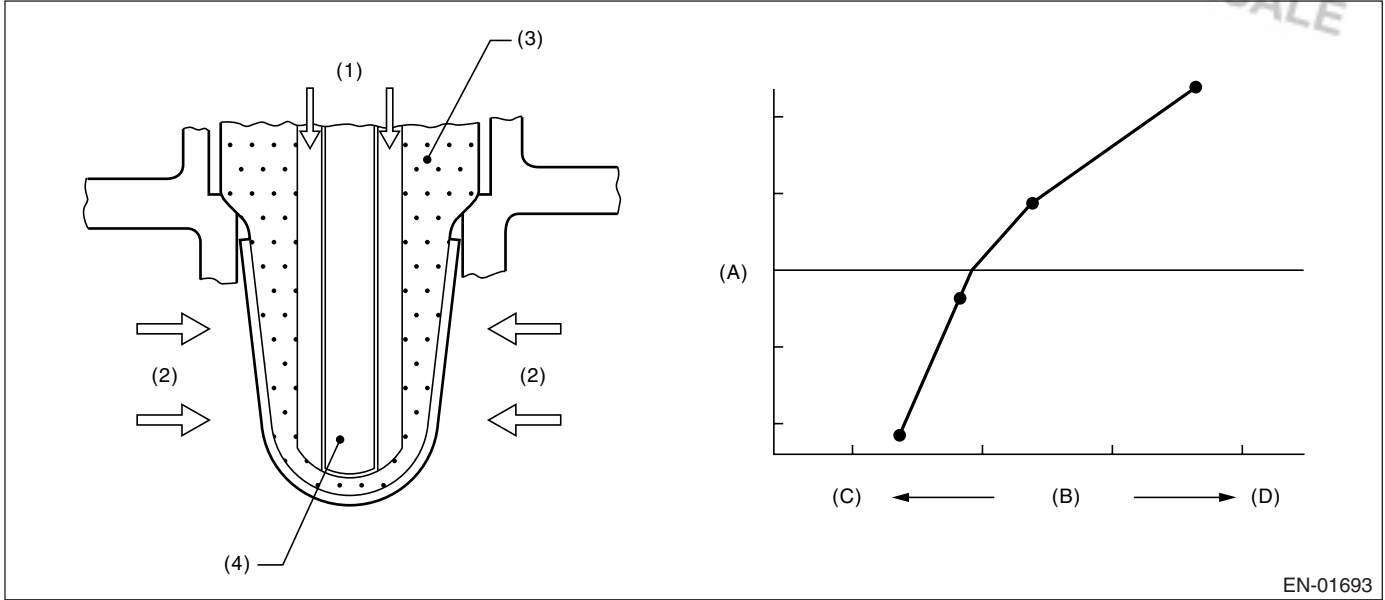

- (1) Atmosphere
- (2) Exhaust
- (3) ZrO<sub>2</sub>
- (4) Ceramic heater

- (A) Electromotive force
- (B) Air fuel ratio
- (C) Lean
- (D) Rich

### 3. ENABLE CONDITION

Secondary Parameters	Enable Conditions
Diagnosis of A/F response	Not done
Battery voltage	> 10.9 V
Atmospheric pressure	> 75.1 kPa (563 mmHg, 22.2 inHg)
Closed loop control with main feedback	operating
Impedance of front oxygen (A/F) sensor	0 ↔ 52 Ω
After engine starting	120 seconds or more
Engine coolant temperature	≥ 75°C (167°F)
Engine speed	1,000 ↔ 3,200 rpm
Vehicle speed	10 ↔ 120 km/h (6.21 ↔ 74.6 MPH)
Amount of intake air	10 ↔ 31 g/s
Engine load change during 0.5 engine rev.	≤ 0.01 g/rev
All conditions for EVAP canister purge	to be in enable
Learning value of EVAP conc. during purge	≤ 0.2
Total time of operating canister purge	20 seconds or more

### 4. GENERAL DRIVING CYCLE

Perform diagnosis only once at a constant speed of 10 to 120 km/h (6.21 to 74.6 MPH) in 120 seconds after starting the engine.

# Diagnostic Trouble Code (DTC) Detecting Criteria

GENERAL DESCRIPTION

## 5. DIAGNOSTIC METHOD

Integrate the difference of  $faf$  in every 131 milliseconds and difference of  $\lambda$  value.

After integrate 1,640 times (215 seconds), calculate the diagnosis value.

Judge NG when the malfunction criteria below are completed. Judge OK and clear NG when the malfunction criteria below are not completed.

### Judgment Value

Malfunction Criteria	Threshold Value
$para_{fca} = td2_{faf}/td2_{lmd}$ where, $td2_{faf}(N) = td2_{faf}(n-1) +  d2_{faf}(n) $ $td2_{lmd}(N) = td2_{lmd}(n-1) +  d2_{lmd}(n) $ add up for a total of 215 seconds $d2_{faf}(n) = (faf(n) - faf(n-1)) - (faf(n-1) - faf(n-2))$ $d2_{lmd}(n) = (lmd(n) - lmd(n-1)) - (lmd(n-1) - lmd(n-2))$ $faf$ = main feedback compensation coefficient every 131 milliseconds $lmd$ = output lambda every 131 milliseconds	$\geq 0.30$

**Time Needed for Diagnosis:** 215 seconds

**Malfunction Indicator Light Illumination:** Illuminates when malfunction occurs in 2 continuous driving cycles.

## 6. DTC CLEAR CONDITION

- When the OK idling cycle was completed 40 times in a row
- When "Clear Memory" was performed

## 7. MALFUNCTION INDICATOR LIGHT CLEAR CONDITION

- When the OK driving cycle was completed 3 times in a row
- When "Clear Memory" was performed

## 8. FAIL SAFE

- Front oxygen (A/F) sensor main learning correction: Not allowed to calculate.
- Correction when re-starting at high temperature: Normally minimum value 0.3  $\rightarrow$  0.
- Purge control: Not allowed to purge.

## 9. ECM OPERATING AT DTC SETTING

- Memorize the freeze frame data. (For test mode \$02)
- Memorize the diagnostic value and trouble standard value. (For test mode \$06)

# Diagnostic Trouble Code (DTC) Detecting Criteria

## GENERAL DESCRIPTION

### Y: DTC P0134 O<sub>2</sub> SENSOR CIRCUIT NO ACTIVITY DETECTED (BANK 1 SENSOR 1)

#### 1. OUTLINE OF DIAGNOSIS

Detect the open circuit of front oxygen (A/F) sensor heater. Diagnosis is performed using front oxygen (A/F) sensor IC, and communication is established between front oxygen (A/F) sensor IC and main IC. Front oxygen (A/F) sensor judges NG when the impedance of front oxygen (A/F) sensor is abnormal.

#### 2. COMPONENT DESCRIPTION

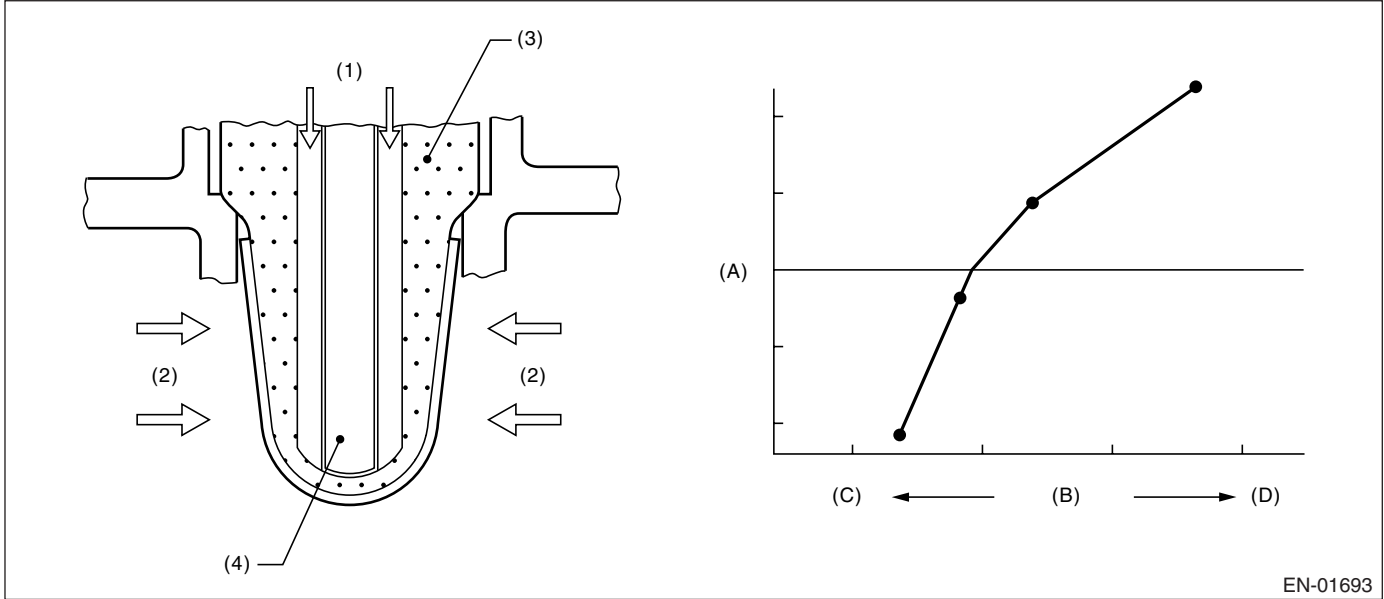

- (1) Atmosphere
- (2) Exhaust
- (3) ZrO<sub>2</sub>
- (4) Ceramic heater

- (A) Electromotive force
- (B) Air fuel ratio
- (C) Lean
- (D) Rich

EN-01693

#### 3. ENABLE CONDITION

Secondary Parameters	Enable Conditions
None	

#### 4. GENERAL DRIVING CYCLE

Always perform the diagnosis continuously.

#### 5. DIAGNOSTIC METHOD

Front oxygen (A/F) sensor judges NG when the continuous time until completing the malfunction criteria below becomes more than the time needed for diagnosis (4.6 seconds). Front oxygen (A/F) sensor judges OK and clear NG when the malfunction criteria below are not completed.

##### Judgment Value

Malfunction Criteria	Threshold Value
Impedance of front oxygen (A/F) sensor	> 500 Ω

**Time Needed for Diagnosis:** 4.6 seconds

**Malfunction Indicator Light Illumination:** Illuminates as soon as the malfunction occurs.

#### 6. DTC CLEAR CONDITION

- When the OK idling cycle was completed 40 times in a row
- When "Clear Memory" was performed

## Diagnostic Trouble Code (DTC) Detecting Criteria

GENERAL DESCRIPTION

### 7. MALFUNCTION INDICATOR LIGHT CLEAR CONDITION

- When the OK driving cycle was completed 3 times in a row
- When "Clear Memory" was performed

### 8. FAIL SAFE

- Front oxygen (A/F) sensor IC communication: Not allowed to communicate
- Front oxygen (A/F) sensor main learning correction: Not allowed to calculate
- Correction when re-starting at high temperature: Normally minimum value 0.3 → 0.
- Purge control: Not allowed to purge

### 9. ECM OPERATING AT DTC SETTING

Memorize the freeze frame data. (For test mode \$02)

# Diagnostic Trouble Code (DTC) Detecting Criteria

## GENERAL DESCRIPTION

### Z: DTC P0137 O<sub>2</sub> SENSOR CIRCUIT LOW VOLTAGE (BANK 1 SENSOR 2)

#### 1. OUTLINE OF DIAGNOSIS

Detect the malfunction of rear oxygen sensor open or short circuit. Judge NG when the rear oxygen sensor voltage may be abnormal from rear oxygen sensor voltage value with considering the conditions such as intake air amount, engine coolant temperature, main feedback control.

#### 2. COMPONENT DESCRIPTION

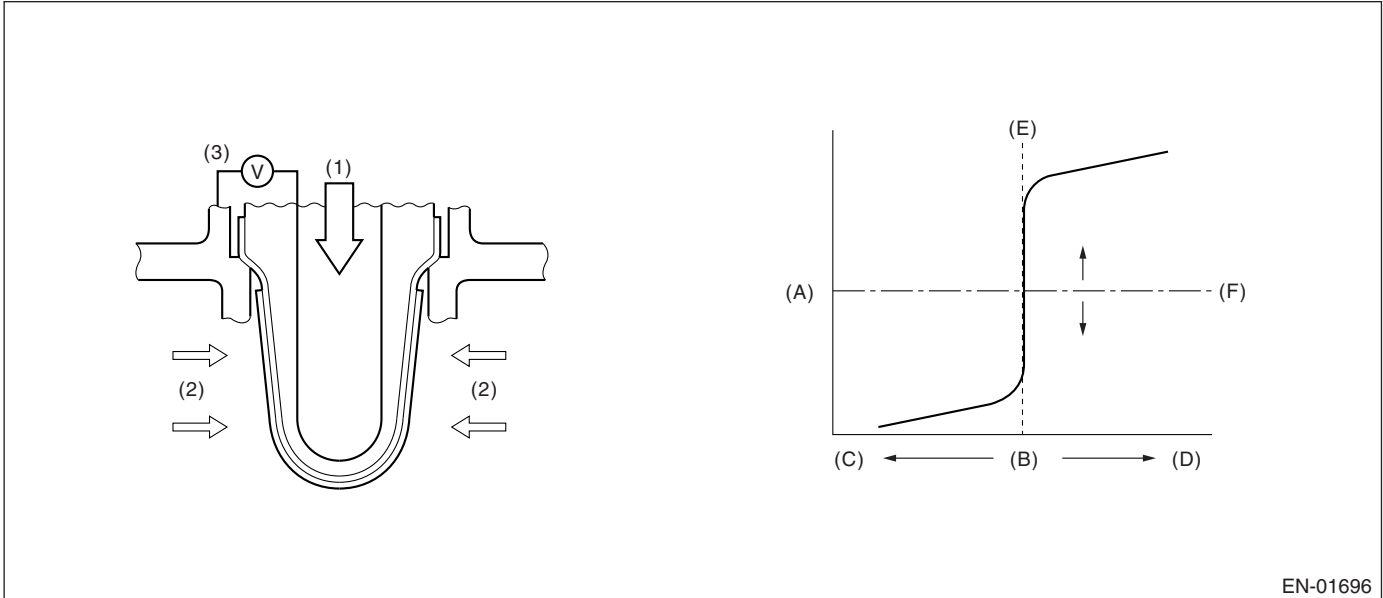

- (1) Atmosphere
- (2) Exhaust
- (3) Electromotive force

- (A) Electromotive force
- (B) Air fuel ratio
- (C) Rich
- (D) Lean
- (E) Theoretical air fuel ratio
- (F) Comparative voltage

#### 3. ENABLE CONDITION (USED ONLY FOR MALFUNCTION JUDGMENT)

Secondary Parameters	Enable Conditions
Low side diagnosis of rear oxygen sensor voltage with main feedback control	Incomplete
Closed loop control with main feedback control	In operation
Target output voltage of rear oxygen sensor with main feedback control	≥ 0.54 V
Amount of intake air with main feedback control	≥ 10 g/s
Engine coolant temperature with main feedback control	≥ 75°C (167°F)
Misfire detection during 200 engine revs.	< 5 times
Compensation factor for front oxygen (A/F) sensor with main feedback control	Not in limit value
Battery voltage with main feedback control	> 10.9 V
Cumulative time for completing the conditions with main feedback control	≥ 200 seconds
5 seconds or more fuel shut-off in decel.	Experienced

# Diagnostic Trouble Code (DTC) Detecting Criteria

GENERAL DESCRIPTION

## 4. GENERAL DRIVING CYCLE

Perform the diagnosis once after starting the engine.

## 5. DIAGNOSTIC METHOD

### • Abnormality Judgment

Judge NG when the malfunction criteria below are completed.

#### Judgment Value

Malfunction Criteria	Threshold Value
Max. output voltage	< 490 mV

**Time Needed for Diagnosis:** 200 seconds

**Malfunction Indicator Light Illumination:** Illuminates when malfunction occurs in 2 continuous driving cycles.

### • Normality Judgment

Judge OK when the malfunction criteria below are completed.

#### Judgment Value

Malfunction Criteria	Threshold Value
Low side diagnosis of rear oxygen sensor voltage	Incomplete
Max. output voltage	$\geq 490$ mV

## 6. DTC CLEAR CONDITION

- When the OK idling cycle was completed 40 times in a row
- When "Clear Memory" was performed

## 7. MALFUNCTION INDICATOR LIGHT CLEAR CONDITION

- When the OK driving cycle was completed 3 times in a row
- When "Clear Memory" was performed

## 8. FAIL SAFE

Sub feedback control: Not allowed

## 9. ECM OPERATING AT DTC SETTING

Memorize the freeze frame data. (For test mode \$02)

# Diagnostic Trouble Code (DTC) Detecting Criteria

## GENERAL DESCRIPTION

### AA:DTC P0138 O<sub>2</sub> SENSOR CIRCUIT HIGH VOLTAGE (BANK 1 SENSOR 2)

#### 1. OUTLINE OF DIAGNOSIS

Detect the malfunction of rear oxygen sensor open or short circuit. Judge NG when the rear oxygen sensor voltage may be abnormal with considering the conditions such as intake air amount, engine coolant temperature, main feedback control.

#### 2. COMPONENT DESCRIPTION

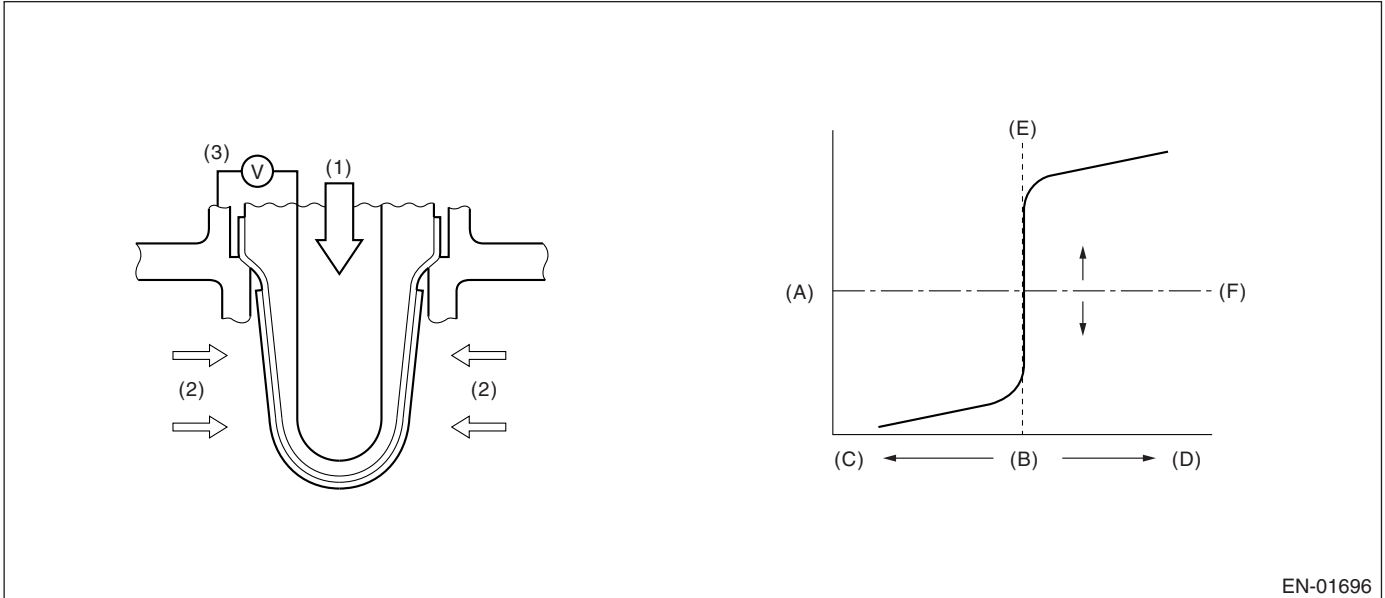

- (1) Atmosphere
- (2) Exhaust
- (3) Electromotive force

- (A) Electromotive force
- (B) Air fuel ratio
- (C) Rich
- (D) Lean
- (E) Theoretical air fuel ratio
- (F) Comparative voltage

#### 3. ENABLE CONDITION (USED ONLY FOR MALFUNCTION JUDGMENT)

Secondary Parameters	Enable Conditions
High side diagnosis of rear oxygen sensor voltage with main feedback control	Incomplete
Closed loop control with main feedback control	In operation
Target output voltage of rear oxygen sensor with main feedback control	≥ 0.54 V
Amount of intake air with main feedback control	≥ 10 g/s
Engine coolant temperature with main feedback control	≥ 75°C (167°F)
Misfire detection during 200 engine revs.	< 5 times
Compensation factor for front oxygen (A/F) sensor with main feedback control	Not in limit value
Battery voltage with main feedback control	> 10.9 V
Cumulative time for completing the conditions with main feedback control	≥ 200 seconds
5 seconds or more fuel shut-off in decel.	Experienced

# Diagnostic Trouble Code (DTC) Detecting Criteria

GENERAL DESCRIPTION

## 4. GENERAL DRIVING CYCLE

Perform the diagnosis once after starting the engine.

## 5. DIAGNOSTIC METHOD

### • Abnormality Judgment

Judge NG when the malfunction criteria below are completed.

#### Judgment Value

Malfunction Criteria	Threshold Value
Min. output voltage	> 250 mV

**Time Needed for Diagnosis:** 200 seconds

**Malfunction Indicator Light Illumination:** Detect when malfunction occurs in 2 continuous driving cycles.

### • Normality Judgment

Judge OK when the malfunction criteria below are completed.

#### Judgment Value

Malfunction Criteria	Threshold Value
High side diagnosis of rear oxygen sensor voltage	Incomplete
Min. output voltage	$\leq$ 250 mV

## 6. DTC CLEAR CONDITION

- When the OK idling cycle was completed 40 times in a row
- When "Clear Memory" was performed

## 7. MALFUNCTION INDICATOR LIGHT CLEAR CONDITION

- When the OK driving cycle was completed 3 times in a row
- When "Clear Memory" was performed

## 8. FAIL SAFE

Sub feedback control: Not allowed

## 9. ECM OPERATING AT DTC SETTING

Memorize the freeze frame data. (For test mode \$02)



# Diagnostic Trouble Code (DTC) Detecting Criteria

## GENERAL DESCRIPTION

### AB:DTC P0139 O<sub>2</sub> SENSOR CIRCUIT SLOW RESPONSE (BANK 1 SENSOR 2)

#### 1. OUTLINE OF DIAGNOSIS

Detect the slow response of rear oxygen sensor.

##### • Diagnostic Method

Measure the response time of the output change of the rear oxygen sensor when the A/F ratio changes from rich to lean. And Judge NG when the measured response time is larger than the threshold value.

#### 2. COMPONENT DESCRIPTION

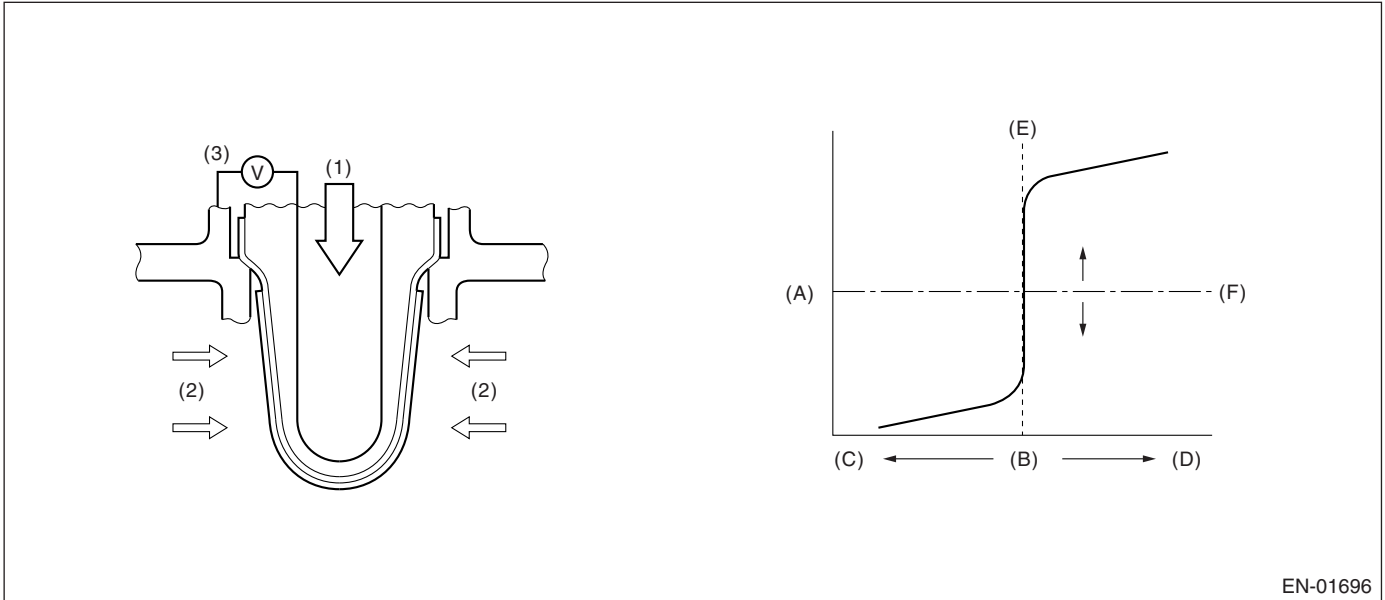

- (1) Atmosphere
- (2) Exhaust
- (3) Electromotive force

- (A) Electromotive force
- (B) Air fuel ratio
- (C) Rich
- (D) Lean
- (E) Theoretical air fuel ratio
- (F) Comparative voltage

#### 3. ENABLE CONDITION

Secondary Parameters	Enable Conditions
Battery voltage	> 10.9 V
A/F main feedback control condition	Completed
Deterioration diagnosis for rear oxygen sensor response	Not completed

#### 4. GENERAL DRIVING CYCLE

Perform the diagnosis only once when fuel shut-off in deceleration after rapid acceleration in order to calculate the diagnostic value. (Pay attention to oxygen sensor voltage for the timing of deceleration.)

# Diagnostic Trouble Code (DTC) Detecting Criteria

GENERAL DESCRIPTION

## 5. DIAGNOSTIC METHOD

When the rear oxygen sensor output voltage changes from 0.5 V (rich) to 0.2 V (lean), calculate the Min. value of response time regarded as judgment value while the output varies from 0.45 V to 0.25 V.

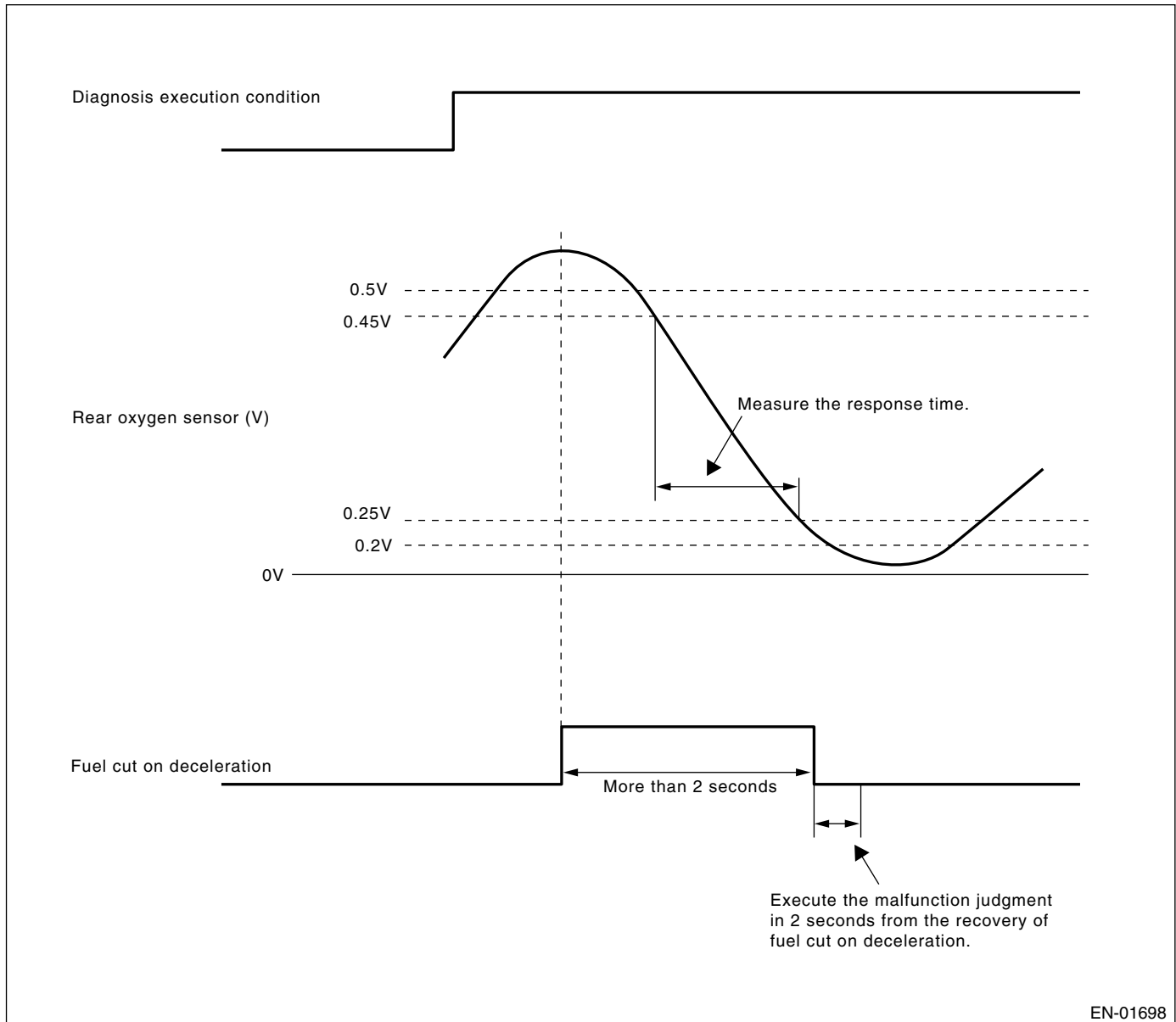

### • Abnormality Judgment

Judge NG when the judgment value is larger than the threshold value after fuel shut-off in deceleration.

Response time (Diagnosis value) > Threshold value → Abnormal

Judge NG when the malfunction criteria below are completed in 2 seconds after the recovery of fuel shut-off in deceleration which requires 5 seconds or more. Judge OK when the malfunction criteria below are not completed regardless of the fuel shut-off in deceleration.

### NOTE:

Variation time of rear oxygen sensor output voltage is short during fuel shut-off in deceleration. Carry out the NG judgment only after the fuel shut-off in deceleration. As for OK judgment, without the condition of fuel shut-off in deceleration, judge OK if the value is below the threshold value.

# Diagnostic Trouble Code (DTC) Detecting Criteria

## GENERAL DESCRIPTION

### Judgment Value

Malfunction Criteria	Threshold Value
Shortest time change from rich (450 mV O <sub>2</sub> output) to lean (250 mV) if voltage reduces from 500 mV to 200 mV.	≥ 327 milliseconds

**Time Needed for Diagnosis:** 5 seconds

**Malfunction Indicator Light Illumination:** Illuminates when malfunction occurs in 2 continuous driving cycles.

### 6. DTC CLEAR CONDITION

- When the OK idling cycle was completed 40 times in a row
- When "Clear Memory" was performed

### 7. MALFUNCTION INDICATOR LIGHT CLEAR CONDITION

- When the OK driving cycle was completed 3 times in a row
- When "Clear Memory" was performed

### 8. FAIL SAFE

Sub feedback control: Not allowed

### 9. ECM OPERATING AT DTC SETTING

- Memorize the freeze frame data. (For test mode \$02)
- Memorize the diagnostic value and trouble standard value. (For test mode \$06)

# Diagnostic Trouble Code (DTC) Detecting Criteria

GENERAL DESCRIPTION

## AC:DTC P0171 SYSTEM TOO LEAN (BANK 1)

### 1. OUTLINE OF DIAGNOSIS

Detect the fuel system malfunction by the amount of main feedback control.

#### • Fuel System Diagnosis

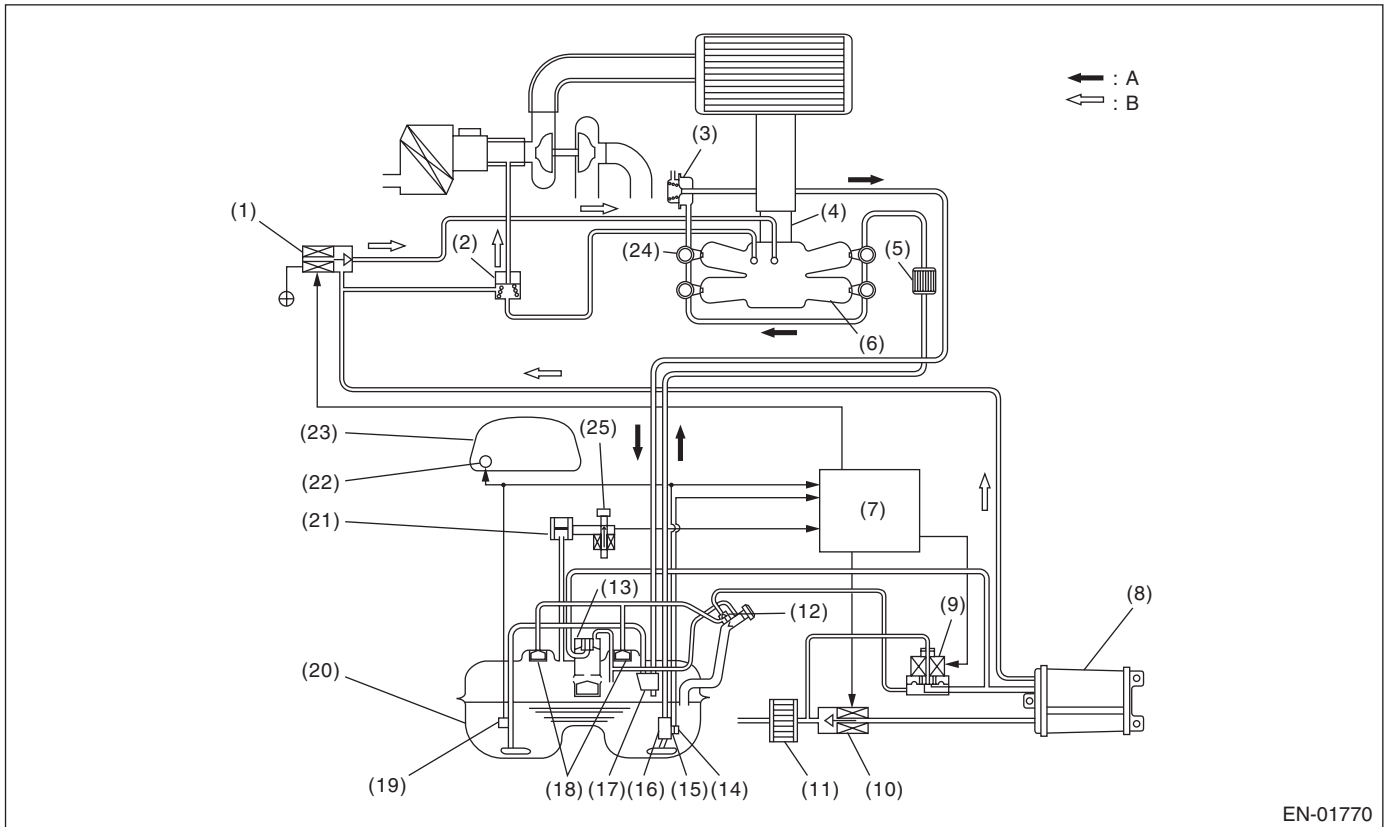

- |                                     |   |
|-------------------------------------|---|
| (1) Purge control solenoid valve    | (14) Fuel temperature sensor                |
| (2) Purge valve                     | (15) Fuel level sensor                      |
| (3) Pressure regulator              | (16) Fuel pump                              |
| (4) Throttle body                   | (17) Jet pump                               |
| (5) Fuel filter                     | (18) Fuel cut valve                         |
| (6) Intake manifold                 | (19) Fuel sub level sensor                  |
| (7) Engine control module (ECM)     | (20) Fuel tank                              |
| (8) Canister                        | (21) Fuel tank pressure sensor              |
| (9) Pressure control solenoid valve | (22) Fuel meter                             |
| (10) Drain valve                    | (23) Combination meter                      |
| (11) Drain filter                   | (24) Fuel injector                          |
| (12) Shut-off valve                 | (25) Tank pressure switching solenoid valve |
| (13) Vent valve                     |   |

#### • Diagnostic Method

Fuel system is diagnosed by comparing the target air fuel ratio calculated by ECM with the actual air fuel ratio measured by sensor.

# Diagnostic Trouble Code (DTC) Detecting Criteria

## GENERAL DESCRIPTION

### 2. ENABLE CONDITION

Secondary Parameters	Enable Conditions
A/F main learning system	In operation
Engine coolant temperature	75 ←→ 119°C (167 ←→ 246°F)
Engine load	Map 5 or more
Intake air change during 0.5 engine rev.	≤ 0.01 g/rev
Learning value of EVAP conc. during purge	≤ 0.1
Cumulative time of canister purge after engine start	20 seconds or more
Continuous period after canister purge starting	30 seconds or more

Map 5

Engine speed (rpm)	idle	800	1,200	1,600	2,000	2,400	2,800	3,200	3,600	4,000	4,400
Measured value (g/rev)	na	0.181	0.173	0.154	0.169	0.171	0.181	0.193	0.201	0.211	0.208

### 3. GENERAL DRIVING CYCLE

Perform the diagnosis continuously at a constant 60 km/h (37.3 MPH).

### 4. DIAGNOSTIC METHOD

#### • Abnormality Judgment

Judge that the fuel system malfunction occurs when the time during completing the malfunction criteria below continues 30 seconds or more by comparing the diagnosed value (fsobd) with threshold value.

#### Judgment Value

Malfunction Criteria	Threshold Value
$fsobd = (sglmd - tglmda) + faf + flaf$ where, sglmd = measured lambda tglmda = target lambda  faf = main feedback compensation coefficient every 64 milliseconds flaf = main feedback learning compensation coefficient	$\geq fsobdL1$ See Map 4  fsobdL1 = lean side threshold value of fsobd

Map 4 Threshold value for fuel system malfunction criteria

Amount of air (g/s)	0	2.4	4.7	7	9.4	11.7	
fsobdL1 (%)	40	40	36.9	32.0	27.0	26.5	

**Time Needed for Diagnosis:** 10 seconds × 3 times

**Malfunction Indicator Light Illumination:** Illuminates when malfunction occurs in 2 continuous driving cycles.

#### • Normality Judgment

Judge OK when the malfunction criteria below are continued for 10 seconds.

#### Judgment Value

Malfunction Criteria	Threshold Value
$fsobd = (sglmd - tglmda) + faf + flaf$	< 19%

### 5. DTC CLEAR CONDITION

- When the OK idling cycle was completed 40 times in a row
- When "Clear Memory" was performed

## Diagnostic Trouble Code (DTC) Detecting Criteria

GENERAL DESCRIPTION

### 6. MALFUNCTION INDICATOR LIGHT CLEAR CONDITION

- When OK with similar drive in 3 driving cycles.
- When "Clear Memory" was performed

### 7. FAIL SAFE

Rich side malfunction

- Purge control solenoid valve control: Not allowed to purge.
- Heavy fuel judgment control: Not allowed to carry out the heavy judgment.

### 8. ECM OPERATING AT DTC SETTING

- Memorize the freeze frame data. (For test mode \$02)
- Memorize the diagnostic value and trouble standard value. (For test mode \$06)

# Diagnostic Trouble Code (DTC) Detecting Criteria

## GENERAL DESCRIPTION

### AD:DTC P0172 SYSTEM TOO RICH (BANK 1)

#### 1. OUTLINE OF DIAGNOSIS

Detect the fuel system malfunction by the amount of main feedback control.

##### • Fuel System Diagnosis

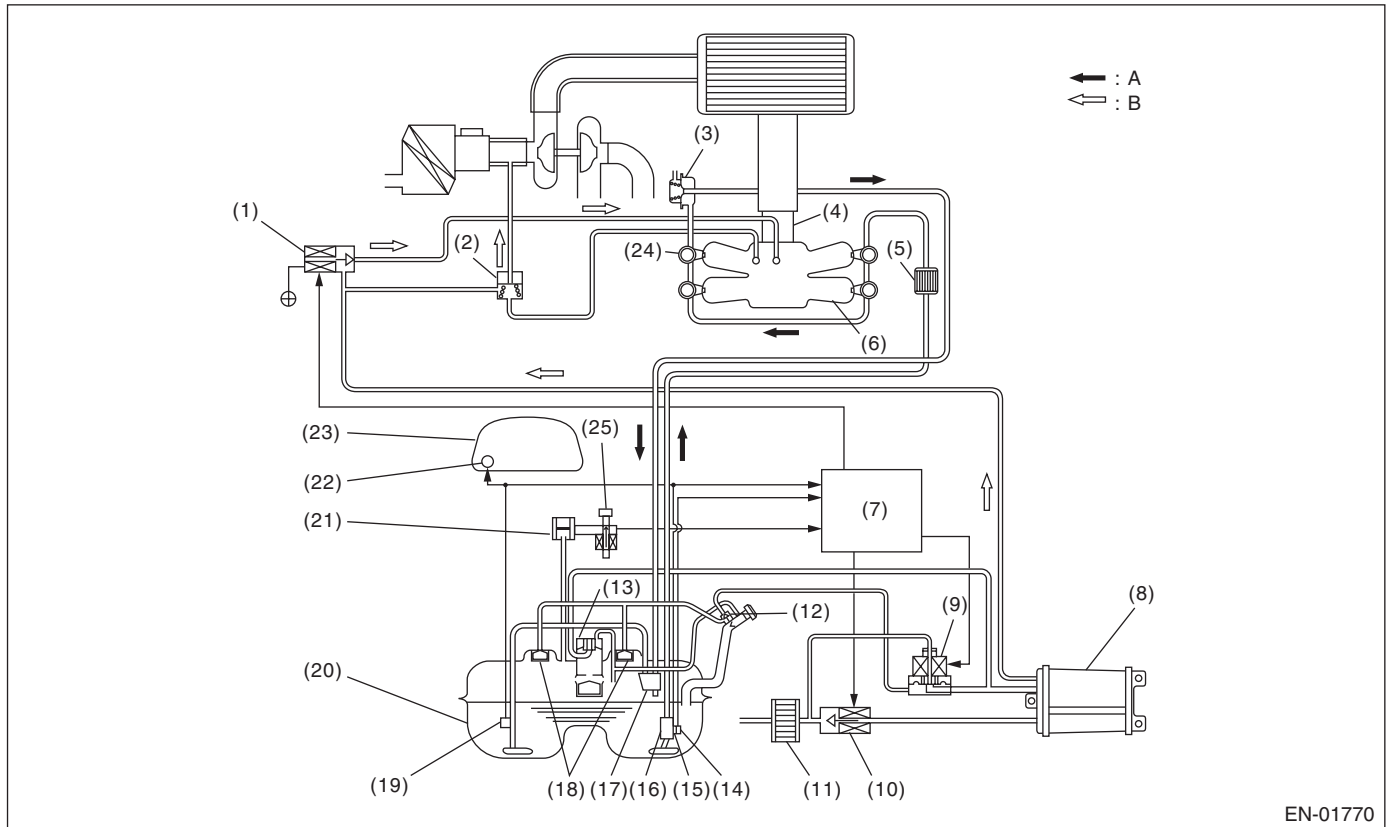

- |                                     |   |
|-------------------------------------|---|
| (1) Purge control solenoid valve    | (14) Fuel temperature sensor                |
| (2) Purge valve                     | (15) Fuel level sensor                      |
| (3) Pressure regulator              | (16) Fuel pump                              |
| (4) Throttle body                   | (17) Jet pump                               |
| (5) Fuel filter                     | (18) Fuel cut valve                         |
| (6) Intake manifold                 | (19) Fuel sub level sensor                  |
| (7) Engine control module (ECM)     | (20) Fuel tank                              |
| (8) Canister                        | (21) Fuel tank pressure sensor              |
| (9) Pressure control solenoid valve | (22) Fuel meter                             |
| (10) Drain valve                    | (23) Combination meter                      |
| (11) Drain filter                   | (24) Fuel injector                          |
| (12) Shut-off valve                 | (25) Tank pressure switching solenoid valve |
| (13) Vent valve                     |   |

##### • Diagnostic Method

Fuel system is diagnosed by comparing the target air fuel ratio calculated by ECM with the actual air fuel ratio measured by sensor.

# Diagnostic Trouble Code (DTC) Detecting Criteria

GENERAL DESCRIPTION

## 2. ENABLE CONDITION

Secondary Parameters	Enable Conditions
A/F main learning system	In operation
Engine coolant temperature	75 ←→ 119°C (167 ←→ 246°F)
Engine load	Map 5 or more
Intake air change during 0.5 engine rev.	≤ 0.01 g/rev
Learning value of EVAP conc. during purge	≤ 0.1
Cumulative time of canister purge after engine start	20 seconds or more
Continuous period after canister purge starting	30 seconds or more

Map 5

Engine speed (rpm)	idle	800	1,200	1,600	2,000	2,400	2,800	3,200	3,600	4,000	4,400
Measured value (g/rev)	na	0.181	0.173	0.154	0.169	0.171	0.181	0.193	0.201	0.211	0.208

## 3. GENERAL DRIVING CYCLE

Perform the diagnosis continuously at a constant 60 km/h (37.3 MPH).

## 4. DIAGNOSTIC METHOD

### • Abnormality Judgment

Judge that the fuel system malfunction occurs when the time during completing the malfunction criteria below continues 30 seconds or more by comparing the diagnosed value (fsobd) with threshold value.

### Judgment Value

Malfunction Criteria	Threshold Value
$fsobd = (sglmd - tglmda) + faf + flaf$ where, sglmd = measured lambda  tglmda = target lambda faf = main feedback compensation coefficient every 64 milliseconds flaf = main feedback learning compensation coefficient	$\leq fsobdR1$ See Map 4 fsobdR1 = rich side threshold value of fsobd

Map 4

Amount of air (g/s)	0	2.4	4.7	7	9.4	11.7	
fsobdR1 (%)	-40	-40	-36.9	-32.0	-27.0	-27.0	

**Time Needed for Diagnosis:** 10 seconds × 3 times

**Malfunction Indicator Light Illumination:** Illuminates when malfunction occurs in 2 continuous driving cycles.

### • Normality Judgment

Judge OK when the malfunction criteria below are continued for 10 seconds.

### Judgment Value

Malfunction Criteria	Threshold Value
$fsobd = (sglmd - tglmda) + faf + flaf$	$\geq -20\%$

## 5. DTC CLEAR CONDITION

- When the OK idling cycle was completed 40 times in a row
- When "Clear Memory" was performed



## Diagnostic Trouble Code (DTC) Detecting Criteria

### GENERAL DESCRIPTION

---

#### 6. MALFUNCTION INDICATOR LIGHT CLEAR CONDITION

- When OK with similar drive in 3 drive cycles.
- When “Clear Memory” was performed

#### 7. FAIL SAFE

Rich side malfunction

- Purge control solenoid valve control: Not allowed to purge.
- Heavy fuel judgment control: Not allowed to carry out the heavy judgment.

#### 8. ECM OPERATING AT DTC SETTING

- Memorize the freeze frame data. (For test mode \$02)
- Memorize the diagnostic value and trouble standard value. (For test mode \$06)

# Diagnostic Trouble Code (DTC) Detecting Criteria

GENERAL DESCRIPTION

## AE:DTC P0181 FUEL TEMPERATURE SENSOR "A" CIRCUIT RANGE/PERFORMANCE

### 1. OUTLINE OF DIAGNOSIS

Detect the malfunction of fuel temperature sensor output property. Perform the diagnosis in two methods; namely, drift diagnosis and stuck diagnosis. Judge NG when either of them results in NG, and judge OK when both of them result in OK.

#### • Drift Diagnosis

Normally fuel temperature is lower than engine coolant temperature. When the fuel temperature becomes higher than the engine coolant temperature, the range is considered to be shifted, and make an NG judgment.

### 2. COMPONENT DESCRIPTION

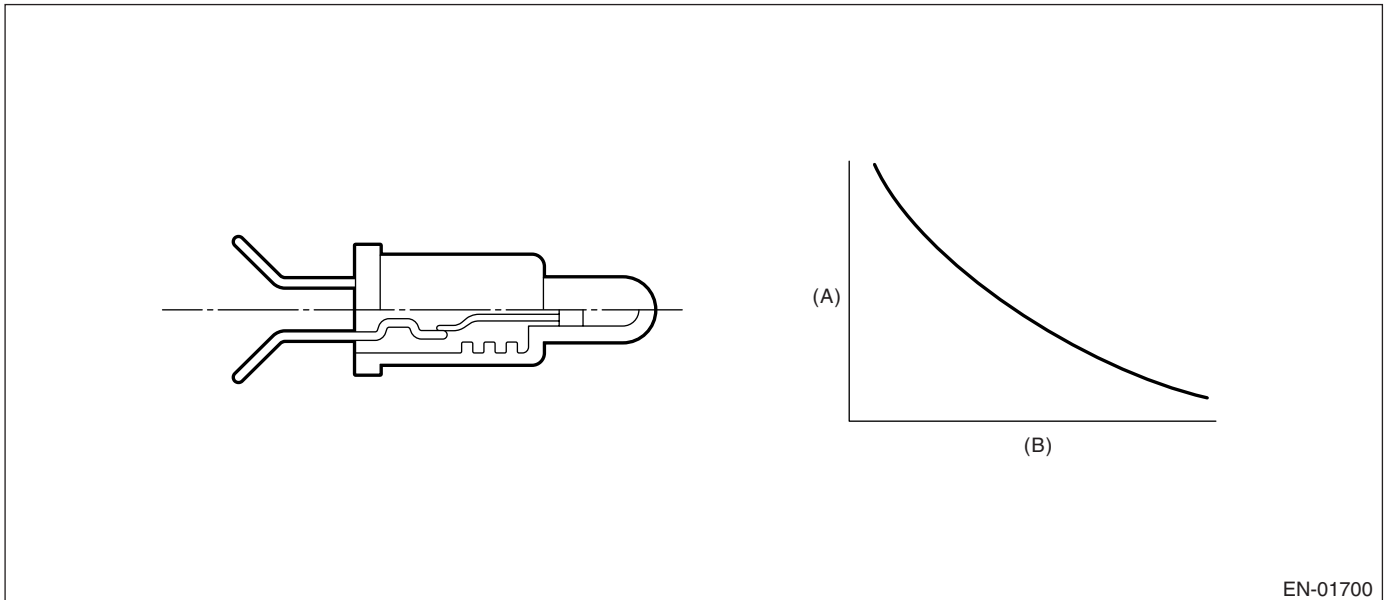

(A) Resistance ( $\Omega$ )

(B) Fuel temperature °C (°F)

### 3. ENABLE CONDITION

Secondary Parameters	Enable Conditions
None	

### 4. GENERAL DRIVING CYCLE

Always perform the diagnosis continuously.

# Diagnostic Trouble Code (DTC) Detecting Criteria

## GENERAL DESCRIPTION

### 5. DIAGNOSTIC METHOD

#### • Abnormality Judgment

Judge NG when the continuous time of completing the malfunction criteria below becomes more than 120 seconds.

#### Judgment Value

Malfunction Criteria	Threshold Value
Fuel level	$\geq 10 \text{ } \emptyset$ (2.64 US gal, 2.20 Imp gal)
After engine starting	20 seconds or more
Engine coolant temperature – engine coolant temperature at engine starting	$> 10^{\circ}\text{C}$ (50°F)
Fuel temperature – engine coolant temperature	$\geq 10^{\circ}\text{C}$ (50°F)
Battery voltage	$> 10.9 \text{ V}$

**Time Needed for Diagnosis:** 120 seconds

**Malfunction Indicator Light Illumination:** Illuminates when malfunction occurs in 2 continuous driving cycles.

#### • Normality Judgment

Judge OK when the malfunction criteria below are completed.

#### Judgment Value

Malfunction Criteria	Threshold Value
Fuel level	$\geq 10 \text{ } \emptyset$ (2.64 US gal, 2.20 Imp gal)
After engine starting	20 seconds or more
Engine coolant temperature – engine coolant temperature at engine starting	$> 10^{\circ}\text{C}$ (50°F)
Fuel temperature – engine coolant temperature	$< 10^{\circ}\text{C}$ (50°F)
Battery voltage	$> 10.9 \text{ V}$

#### • Stuck Diagnosis

If the fuel temperature which might rise along with the engine idling (the cumulative amount of intake air after engine starting is large) does not increase, the engine is considered to be stuck and make an NG judgment.

### 6. ENABLE CONDITION

Secondary Parameters	Enable Conditions
After engine starting	20 seconds or more
Battery voltage	$> 10.9 \text{ V}$

### 7. GENERAL DRIVING CYCLE

Always perform diagnosis continuously.

### 8. DIAGNOSTIC METHOD

#### • Abnormality Judgment

Judge NG when the malfunction criteria below are completed.

#### Judgment Value

Malfunction Criteria	Threshold Value
Accumulated amount of intake air	$\geq 550 \text{ kg}$ (1,212.5 lb)
Fuel temperature difference between Max. and Min.	$< 3^{\circ}\text{C}$ (37.4°F)

**Time Needed for Diagnosis:** To be determined.

# Diagnostic Trouble Code (DTC) Detecting Criteria

GENERAL DESCRIPTION

**Malfunction Indicator Light Illumination:** Illuminates when malfunction occurs in 2 continuous driving cycles.

## • Normality Judgment

Judge OK when the malfunction criteria below are completed.

### Judgment Value

Malfunction Criteria	Threshold Value
Accumulated amount of intake air	$\geq 550$ kg (1,212.5 lb)
Fuel temperature difference between Max. and Min.	$\geq 3^{\circ}\text{C}$ (37.4 $^{\circ}\text{F}$ )

## 9. DTC CLEAR CONDITION

- When the OK idling cycle was completed 40 times in a row
- When "Clear Memory" was performed

## 10.MALFUNCTION INDICATOR LIGHT CLEAR CONDITION

- When the OK driving cycle was completed 3 times in a row
- When "Clear Memory" was performed

## 11.FAIL SAFE

None

## 12.ECM OPERATING AT DTC SETTING

Memorize the freeze frame data. (For test mode \$02)

# Diagnostic Trouble Code (DTC) Detecting Criteria

## GENERAL DESCRIPTION

### AF:DTC P0182 FUEL TEMPERATURE SENSOR "A" CIRCUIT LOW INPUT

#### 1. OUTLINE OF DIAGNOSIS

Detect the open or short circuit of fuel temperature sensor. Judge NG when out of the standard value.

#### 2. COMPONENT DESCRIPTION

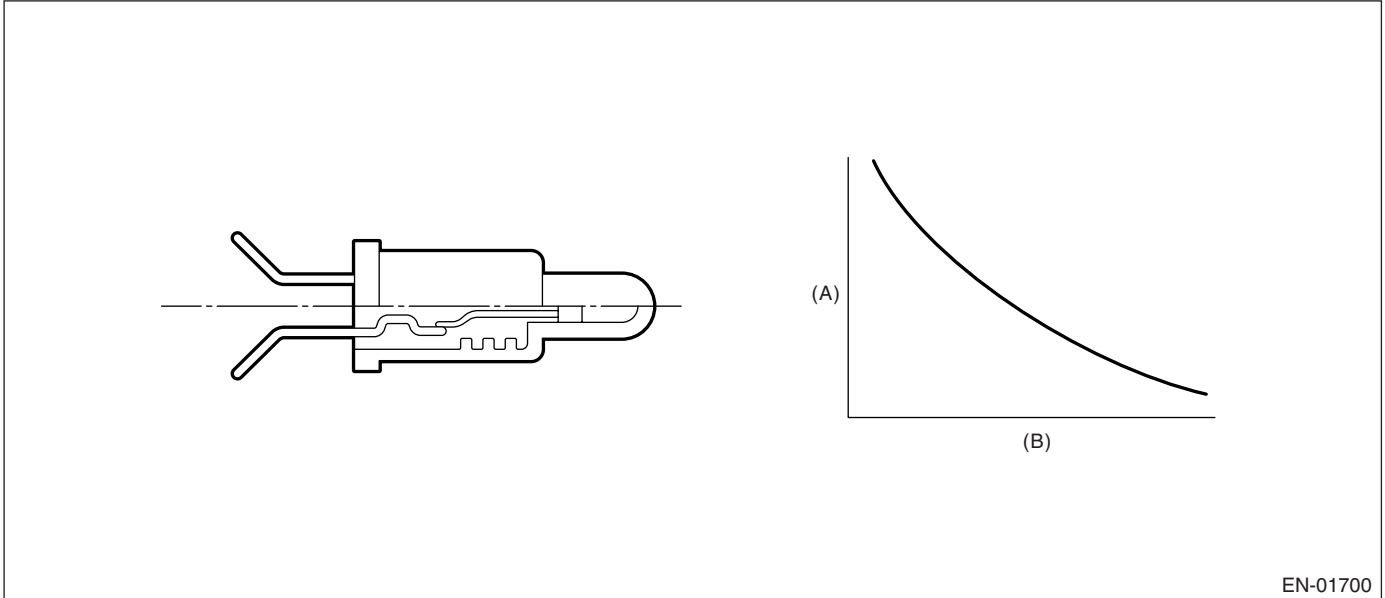

(A) Resistance (Ω)

(B) Fuel temperature °C (°F)

EN-01700

#### 3. ENABLE CONDITION

Secondary Parameters	Enable Conditions
None	

#### 4. GENERAL DRIVING CYCLE

Always perform the diagnosis continuously.

#### 5. DIAGNOSTIC METHOD

##### • Abnormality Judgment

Judge NG when the continuous time of completing the malfunction criteria below becomes more than 2.5 seconds.

##### Judgment Value

Malfunction Criteria	Threshold Value
Output voltage	< 0.245 V
Battery voltage	≥ 10.9 V

**Time Needed for Diagnosis:** 2.5 seconds

**Malfunction Indicator Light Illumination:** Illuminates as soon as the malfunction occurs.

##### • Normality Judgment

Judge OK when the cumulative time until completing the malfunction criteria below becomes more than 2.5 seconds.

##### Judgment Value

Malfunction Criteria	Threshold Value
Output voltage	≥ 0.245 V
Battery voltage	≥ 10.9 V

## Diagnostic Trouble Code (DTC) Detecting Criteria

GENERAL DESCRIPTION

### 6. DTC CLEAR CONDITION

- When the OK idling cycle was completed 40 times in a row
- When "Clear Memory" was performed

### 7. MALFUNCTION INDICATOR LIGHT CLEAR CONDITION

- When the OK driving cycle was completed 3 times in a row
- When "Clear Memory" was performed

### 8. FAIL SAFE

None

### 9. ECM OPERATING AT DTC SETTING

Memorize the freeze frame data. (For test mode \$02)

# Diagnostic Trouble Code (DTC) Detecting Criteria

## GENERAL DESCRIPTION

### AG:DTC P0183 FUEL TEMPERATURE SENSOR "A" CIRCUIT HIGH INPUT

#### 1. OUTLINE OF DIAGNOSIS

Detect the open or short circuit of fuel temperature sensor. Judge NG when out of the standard value.

#### 2. COMPONENT DESCRIPTION

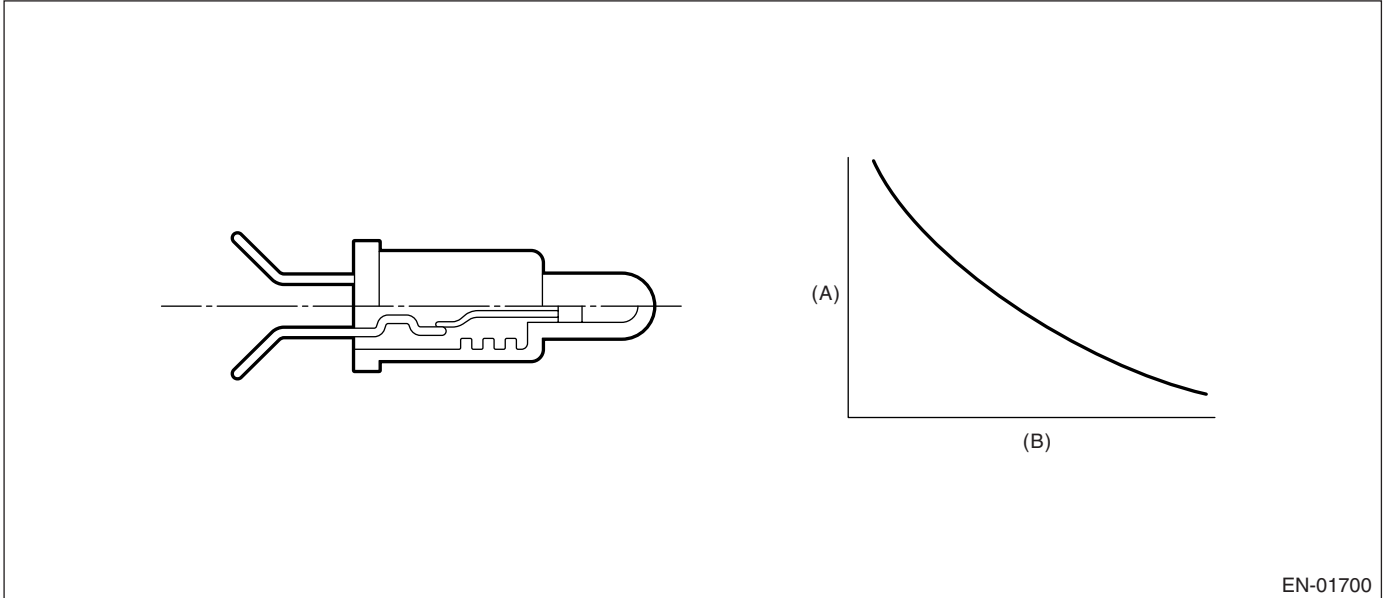

(A) Resistance (Ω)

(B) Fuel temperature °C (°F)

#### 3. ENABLE CONDITION

Secondary Parameters	Enable Conditions
None	

#### 4. GENERAL DRIVING CYCLE

Always perform the diagnosis continuously.

#### 5. DIAGNOSTIC METHOD

##### • Abnormality Judgment

Judge NG when the continuous time of completing the malfunction criteria below becomes more than 2.5 seconds.

##### Judgment Value

Malfunction Criteria	Threshold Value
Output voltage	≥ 4.72 V
Battery voltage	≥ 10.9 V

**Time Needed for Diagnosis:** 2.5 seconds

**Malfunction Indicator Light Illumination:** Illuminates as soon as the malfunction occurs.

##### • Normality Judgment

Judge OK when the cumulative time until completing the malfunction criteria below becomes more than 2.5 seconds.

##### Judgment Value

Malfunction Criteria	Threshold Value
Output voltage	< 4.72 V
Battery voltage	≥ 10.9 V

## Diagnostic Trouble Code (DTC) Detecting Criteria

GENERAL DESCRIPTION

### 6. DTC CLEAR CONDITION

- When the OK idling cycle was completed 40 times in a row
- When "Clear Memory" was performed

### 7. MALFUNCTION INDICATOR LIGHT CLEAR CONDITION

- When the OK driving cycle was completed 3 times in a row
- When "Clear Memory" was performed

### 8. FAIL SAFE

None

### 9. ECM OPERATING AT DTC SETTING

Memorize the freeze frame data. (For test mode \$02)



# Diagnostic Trouble Code (DTC) Detecting Criteria

## GENERAL DESCRIPTION

### AH:DTC P0230 FUEL PUMP PRIMARY CIRCUIT

#### 1. OUTLINE OF DIAGNOSIS

Detect the malfunction of fuel pump control unit. Judge NG when the NG signal is sent through a diagnostic line coming from the fuel pump control unit. Fuel pump control unit detects the open or short circuit malfunction for each line, and then sends NG signals if one of them is found NG.

#### 2. COMPONENT DESCRIPTION

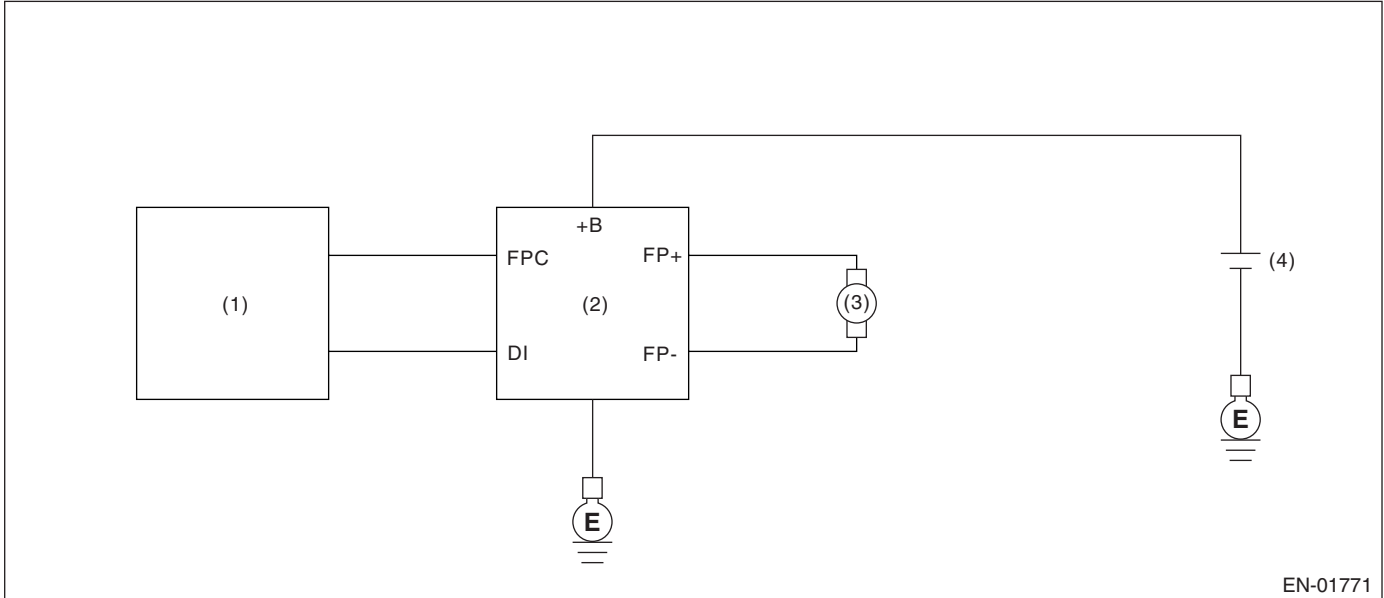

- (1) Engine control module (ECM)
- (2) Fuel pump control unit
- (3) Fuel pump
- (4) Battery

#### 3. ENABLE CONDITION

Secondary Parameters	Enable Conditions
None	

#### 4. GENERAL DRIVING CYCLE

Always perform the diagnosis continuously.

#### 5. DIAGNOSTIC METHOD

##### • Abnormality Judgment

Judge NG when the continuous time of completing the malfunction criteria below becomes more than 2.5 seconds.

##### Judgment Value

Malfunction Criteria	Threshold Value
Battery voltage	≥ 8 V
After engine starting	30 seconds or more
Fuel pump control	ON
Fuel pump control unit output diagnosis signal	Low

**Time Needed for Diagnosis:** 2.5 seconds

**Malfunction Indicator Light Illumination:** Illuminates when malfunction occurs in 2 continuous driving cycles.

# Diagnostic Trouble Code (DTC) Detecting Criteria

GENERAL DESCRIPTION

## • Normality Judgment

Judge OK and clear the NG when the malfunction criteria below are completed.

### Judgment Value

Malfunction Criteria	Threshold Value
Battery voltage	$\geq 8$ V
After engine starting	30 seconds or more
Fuel pump control	ON
Fuel pump control unit output diagnosis signal	High

## 6. DTC CLEAR CONDITION

- When the OK idling cycle was completed 40 times in a row
- When "Clear Memory" was performed

## 7. MALFUNCTION INDICATOR LIGHT CLEAR CONDITION

- When the OK driving cycle was completed 3 times in a row
- When "Clear Memory" was performed

## 8. FAIL SAFE

OFF setting may be needed depending on the NG portion.

## 9. ECM OPERATING AT DTC SETTING

Memorize the freeze frame data. (For test mode \$02)

# Diagnostic Trouble Code (DTC) Detecting Criteria

## GENERAL DESCRIPTION

### AI: DTC P0244 TURBO/SUPER CHARGER WASTEGATE SOLENOID "A" RANGE/PERFORMANCE

#### 1. OUTLINE OF DIAGNOSIS

Detect the malfunction of wastegate control solenoid valve function. Judge NG when becoming high wastegate pressure.

#### 2. COMPONENT DESCRIPTION

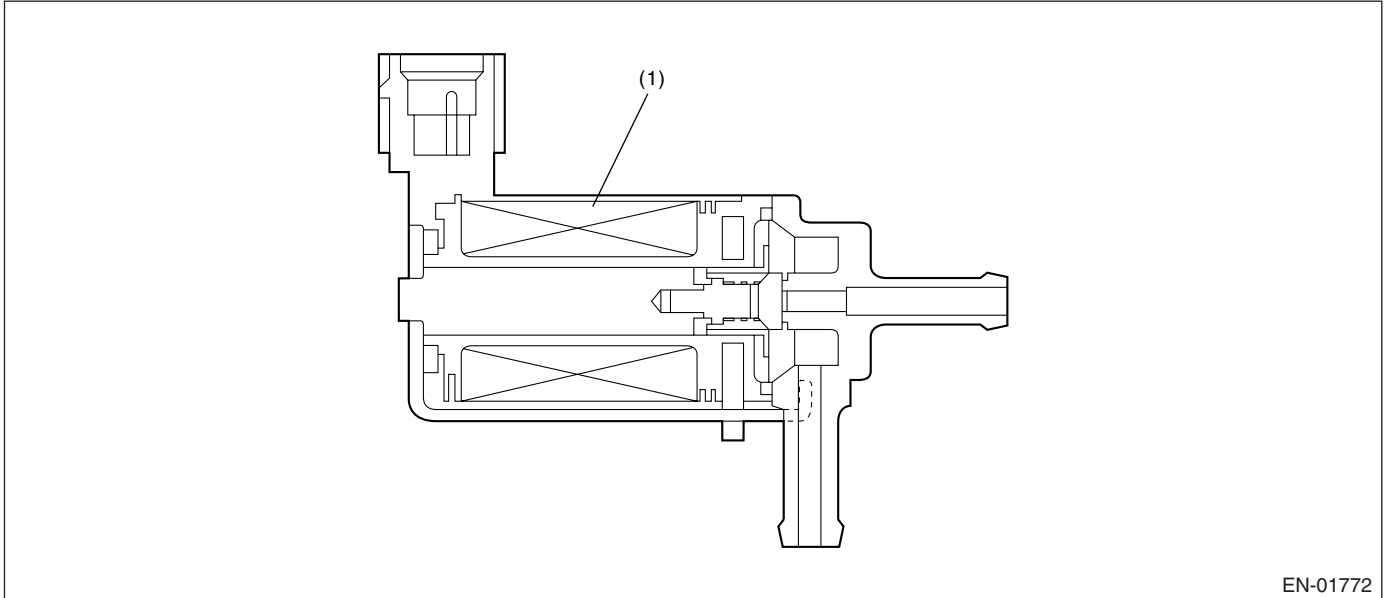

(1) Coil

#### 3. ENABLE CONDITION

Secondary Parameters	Enable Conditions
None	

#### 4. GENERAL DRIVING CYCLE

Always perform the diagnosis continuously.

#### 5. DIAGNOSTIC METHOD

Judge NG when the continuous time of completing the malfunction criteria below becomes more than 1 second. Judge OK and clear the NG when the malfunction criteria below are not completed.

##### Judgment Value

Malfunction Criteria	Threshold Value
Intake manifold pressure	$\geq 240$ kPa (1,800 mmHg, 70.8 inHg)

**Time Needed for Diagnosis:** 1 second

**Malfunction Indicator Light Illumination:** Illuminates as soon as the malfunction occurs.

#### 6. DTC CLEAR CONDITION

- When the OK idling cycle was completed 40 times in a row
- When "Clear Memory" was performed

#### 7. MALFUNCTION INDICATOR LIGHT CLEAR CONDITION

- When the OK driving cycle was completed 3 times in a row
- When "Clear Memory" was performed

## Diagnostic Trouble Code (DTC) Detecting Criteria

GENERAL DESCRIPTION

### 8. FAIL SAFE

None

### 9. ECM OPERATING AT DTC SETTING

Memorize the freeze frame data. (For test mode \$02)

# Diagnostic Trouble Code (DTC) Detecting Criteria

## GENERAL DESCRIPTION

### AJ:DTC P0245 TURBO/SUPER CHARGER WASTEGATE SOLENOID "A" LOW

#### 1. OUTLINE OF DIAGNOSIS

Detect the open or short circuit of wastegate control solenoid valve. Judge NG when the terminal output voltage remains Low during outputting the duty signal.

#### 2. COMPONENT DESCRIPTION

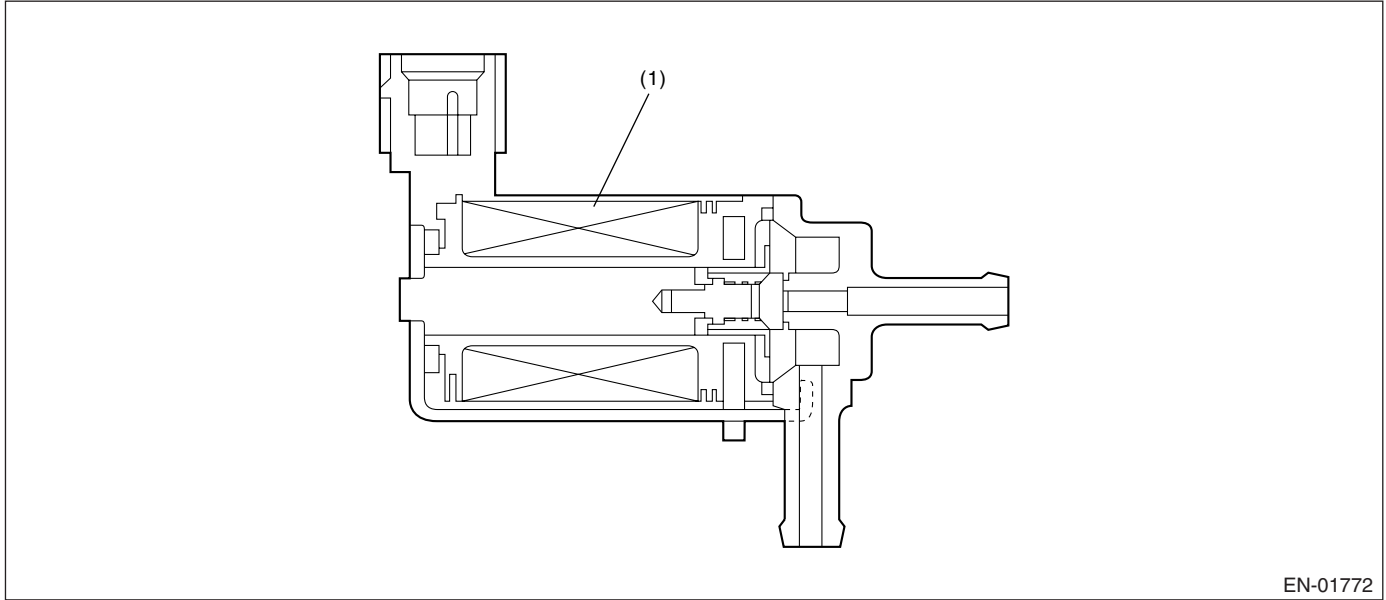

(1) Coil

#### 3. ENABLE CONDITION

Secondary Parameters	Enable Conditions
Battery voltage	> 10.9 V
After engine starting	1 second or more

#### 4. GENERAL DRIVING CYCLE

Perform the diagnosis continuously after engine starts.

#### 5. DIAGNOSTIC METHOD

Judge NG when the continuous time until completing the malfunction criteria below becomes more than 655 milliseconds.

##### Judgment Value

Malfunction Criteria	Threshold Value
Duty ratio for turbocharged pressure control when terminal output voltage is Low	< 75%

**Time Needed for Diagnosis:** 655 milliseconds

**Malfunction Indicator Light Illumination:** Illuminates as soon as the malfunction occurs.

#### 6. DTC CLEAR CONDITION

- When the OK idling cycle was completed 40 times in a row
- When "Clear Memory" was performed

#### 7. MALFUNCTION INDICATOR LIGHT CLEAR CONDITION

- When the OK driving cycle was completed 3 times in a row
- When "Clear Memory" was performed

## Diagnostic Trouble Code (DTC) Detecting Criteria

GENERAL DESCRIPTION

---

### 8. FAIL SAFE

None

### 9. ECM OPERATING AT DTC SETTING

Memorize the freeze frame data. (For test mode \$02)

# Diagnostic Trouble Code (DTC) Detecting Criteria

## GENERAL DESCRIPTION

### AK:DTC P0246 TURBO/SUPER CHARGER WASTEGATE SOLENOID "A" HIGH

#### 1. OUTLINE OF DIAGNOSIS

Detect the open or short circuit of wastegate control solenoid valve. Judge NG when the terminal output voltage remains Low or High during outputting the duty signal.

#### 2. COMPONENT DESCRIPTION

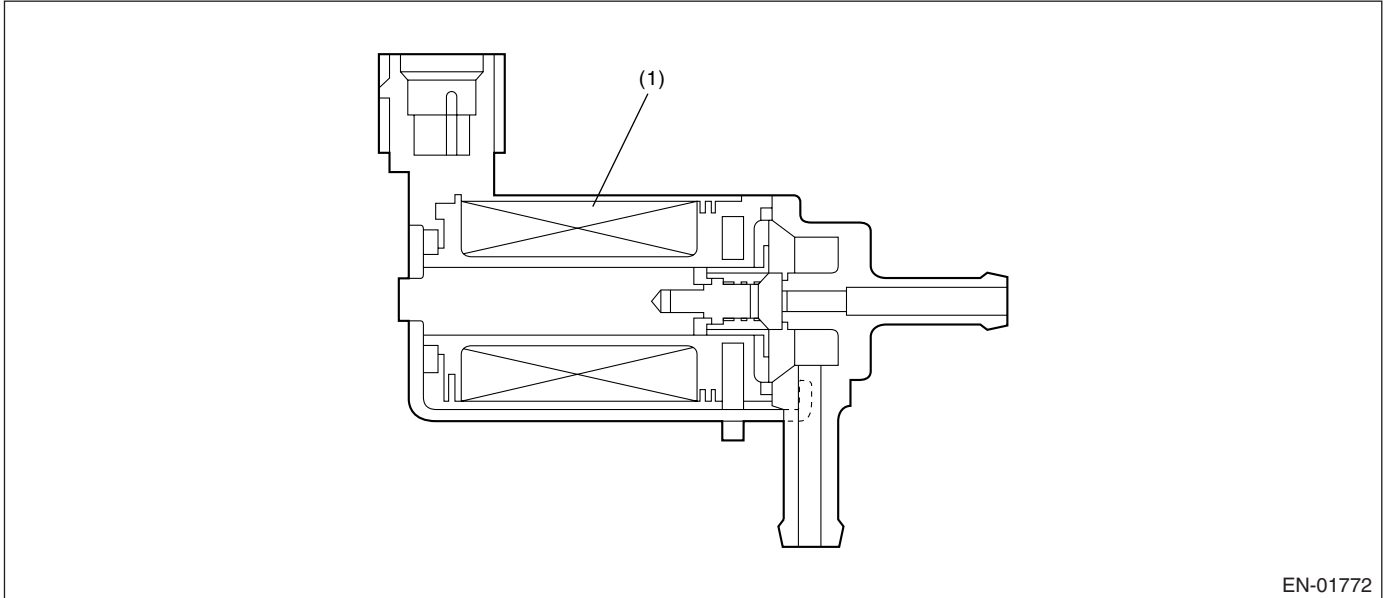

(1) Coil

#### 3. ENABLE CONDITION

Secondary Parameters	Enable Conditions
Battery voltage	> 10.9 V
After engine starting	1 second or more

#### 4. GENERAL DRIVING CYCLE

Perform the diagnosis continuously after engine starts.

#### 5. DIAGNOSTIC METHOD

Judge NG when the continuous time until completing the malfunction criteria below becomes more than 655 milliseconds.

##### Judgment Value

Malfunction Criteria	Threshold Value
Duty ratio for turbocharged pressure control when output terminal voltage is High	> 25%

**Time Needed for Diagnosis:** 655 milliseconds

**Malfunction Indicator Light Illumination:** Illuminates as soon as the malfunction occurs.

#### 6. DTC CLEAR CONDITION

- When the OK idling cycle was completed 40 times in a row
- When "Clear Memory" was performed

#### 7. MALFUNCTION INDICATOR LIGHT CLEAR CONDITION

- When the OK driving cycle was completed 3 times in a row
- When "Clear Memory" was performed

## Diagnostic Trouble Code (DTC) Detecting Criteria

GENERAL DESCRIPTION

### 8. FAIL SAFE

None

### 9. ECM OPERATING AT DTC SETTING

Memorize the freeze frame data. (For test mode \$02)



# Diagnostic Trouble Code (DTC) Detecting Criteria

## GENERAL DESCRIPTION

### AL:DTC P0301 CYLINDER 1 MISFIRE DETECTED

#### 1. OUTLINE OF DIAGNOSIS

Detect whether the misfire occurred or not. (Revolution fluctuation method) Monitoring the misfire which influences exhaust deterioration (1.5 times of FTP) and catalyst damage is made obligatory by the law. Misfire affecting these two has three patterns below.

- Intermittent misfire (The same cylinder misfires in random, or different cylinders misfire in random.): FTP 1.5 times misfire
- Every time misfire (The same cylinder misfires every time.): FTP 1.5 times misfire, Catalyst damage misfire

The following detecting methods are adopted for these detection.

1) Intermittent misfire: FTP 1.5 times misfire

- 180° Interval Difference Method (MT: 1,800 rpm or less; AT: None)
- 360° Interval Difference Method (whole range)
- 720° Interval Difference Method (3,000 rpm or less)

2) Every time misfire: FTP 1.5 times misfire, Catalyst damage misfire

- 360° Interval Difference Method

#### 2. ENABLE CONDITION

Secondary Parameters	Enable Conditions
Intake manifold pressure change during 0.5 engine rev.	< 14.7 kPa (110 mmHg, 4.34 inHg) @AT < 16.0 kPa (120 mmHg, 4.72 inHg) @MT
Engine speed change	< 500 rpm / 32 milliseconds
Throttle position change during 16 milliseconds	< 10°
Fuel shut-off function	Not operating
Atmospheric pressure	≥ 75.1 kPa (563 mmHg, 22.2 inHg)
Fuel level	≥ 9 ℓ (2.38 US gal, 1.98 Imp gal)
AT torque control	Not operating
Air condition	Not switching ON ↔ OFF
Radiator fan	Not switching ON ↔ OFF
Power steering switch	Not switching ON ↔ OFF
Starter	ON or OFF or change from ON to OFF
Evaporative system leak check	Not in operation
Engine speed	500 — 7,000 rpm
Intake manifold pressure	> Map 3 or more
Battery voltage	≥ 8 V

# Diagnostic Trouble Code (DTC) Detecting Criteria

GENERAL DESCRIPTION

## Map3

### MT (Vehicle Speed < 64.4 km/h (40 MPH))

rpm	700	1,000	1,500	2,000	2,500	3,000	3,500	4,000	4,500	5,000	5,500	6,000	6,500	7,000
kPa	29.5	28.5	28.4	28.4	28.4	26.5	29.8	31.6	33.9	35.1	36.6	41.7	46.7	52.3
(mmHg, inHg)	(221, 8.70)	(214, 8.41)	(213, 8.38)	(213, 8.38)	(213, 8.38)	(199, 7.82)	(223.5, 8.79)	(237, 9.32)	(254.5, 10.0)	(263, 10.4)	(274.5, 10.8)	(313, 12.3)	(350.5, 13.8)	(392, 15.4)

### MT (Vehicle Speed ≥ 64.4 km/h (40 MPH))

rpm	700	1,000	1,500	2,000	2,500	3,000	3,500	4,000	700	4,500	5,000	5,500	6,000	6,500
kPa	29.5	28.5	34.9	41.3	43.6	42.4	47.1	46.3	29.5	49.6	49.1	49.9	50.7	51.5
(mmHg, inHg)	(221, 8.70)	(214, 8.41)	(261.8, 10.3)	(309.5, 12.2)	(326.8, 12.9)	(318.1, 12.5)	(353.6, 13.9)	(347.1, 13.7)	(221, 8.70)	(371.9, 14.6)	(368.3, 14.5)	(374.2, 14.7)	(380.2, 15.0)	(386.1, 15.2)

## AT

rpm	700	1,000	1,500	2,000	2,500	3,000	3,500	4,000	4,500	5,000	5,500	6,000	6,500	7,000
kPa	32.7	25.9	26.1	27.5	28.4	26.4	31.8	31.1	35.8	37.6	39.0	43.3	48.6	52.3
(mmHg, inHg)	(242, 9.65)	(194, 7.64)	(196, 7.70)	(206, 8.11)	(213, 8.38)	(198, 7.79)	(238.5, 9.38)	(256, 9.17)	(268.5, 10.6)	(282, 11.1)	(292.5, 11.5)	(325, 12.8)	(364.5, 14.3)	(392, 15.4)

## 3. GENERAL DRIVING CYCLE

- Detecting misfire is able to be carried out in the condition between idling and high revolution; however, idling condition is better for detecting misfire from the viewpoint of engine load and damage.
- Perform the diagnosis continuously.

## 4. DIAGNOSTIC METHOD

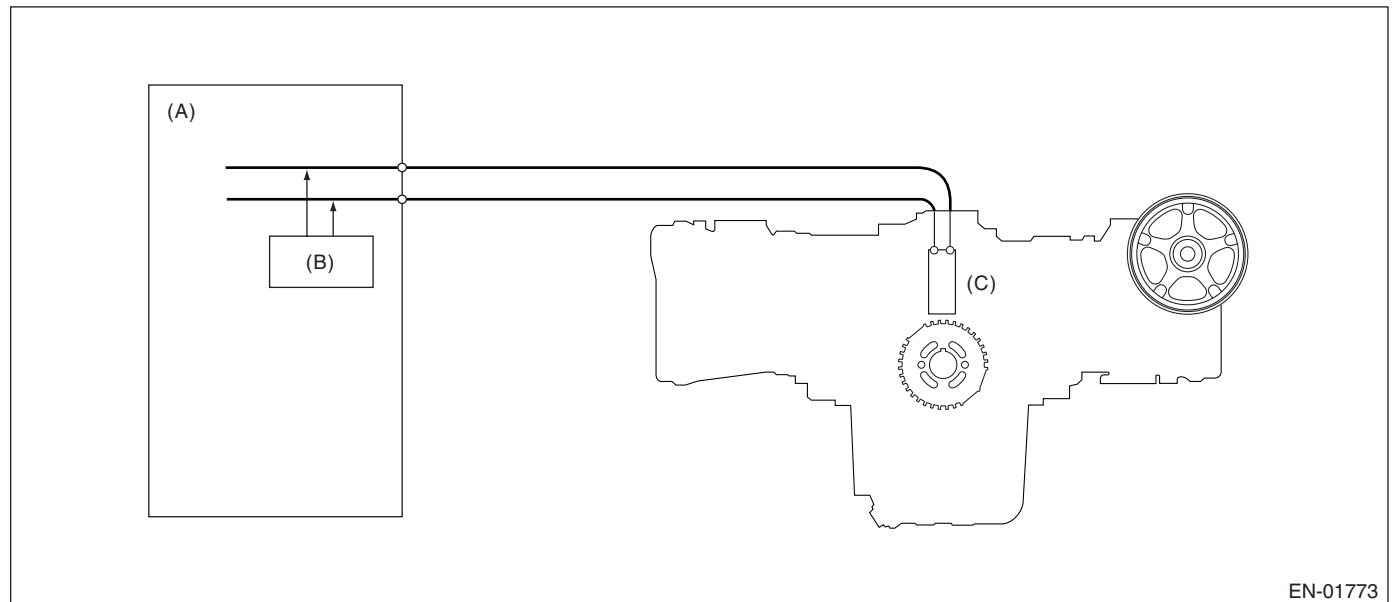

- (A) Engine control module (ECM)
- (B) Diagnosis circuit
- (C) Crankshaft position sensor

When the misfire occurred, the engine speed is decreased and the crankshaft position speed will change. Calculate the interval difference value (diagnostic value) from crankshaft position speed by the following formula, and judge whether the misfire occurs or not comparing the calculated result with judgment value. Counting the number of misfire up, and if the misfire ratio is higher during 1,000 rev. or 200 rev., judge NG for the corresponding cylinder.

# Diagnostic Trouble Code (DTC) Detecting Criteria

## GENERAL DESCRIPTION

Calculate the diagnostic value (from crankshaft position speed)

- Misfire detection every single ignition (Compare diagnostic value with judgment value)
- 180° Interval Difference Method
  - 360° Interval Difference Method
  - 720° Interval Difference Method

- NG judgment (Judge misfire occurrence required by the law) (Compare number of misfire with judgment)
- FTP1.5 times misfire NG judgment
  - Catalyst damage misfire NG judgment

As the following figure, pick out a random cylinder as the standard and name it omg 0. And the former crankshaft position speed is named omg 1, the second former crankshaft position speed is named omg 2, the third is named omg 3, and the following is the same.

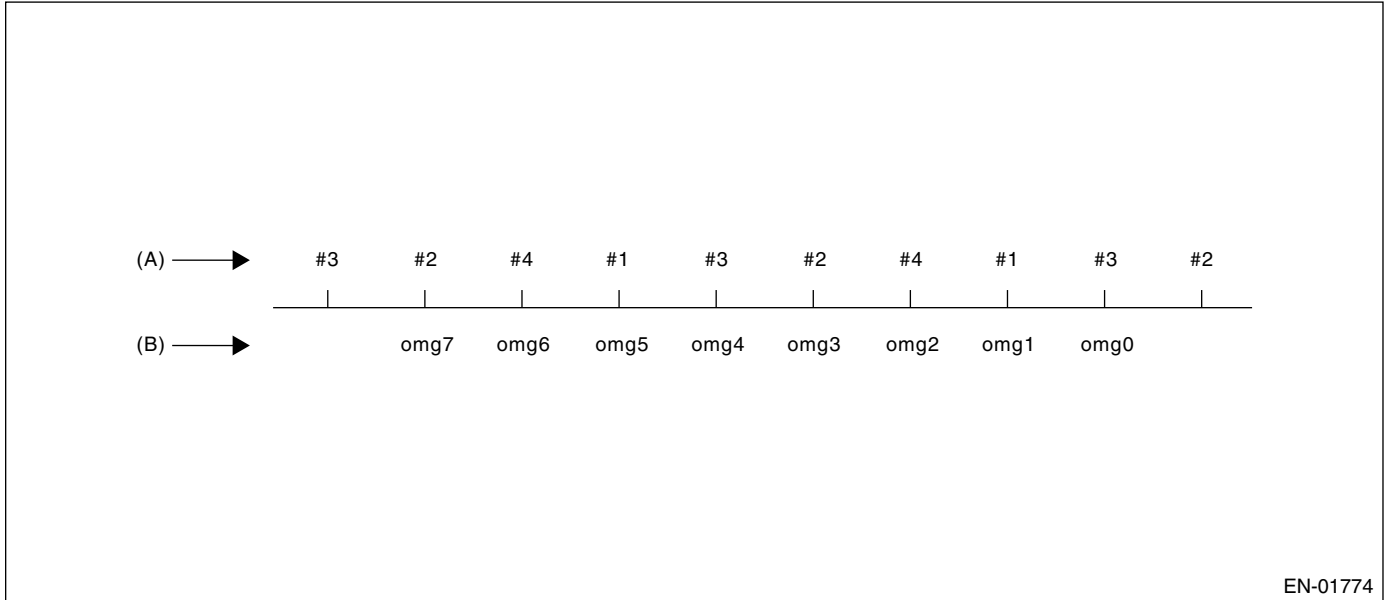

EN-01774

- (A) Ignition order  
(B) Crankshaft position speed

# Diagnostic Trouble Code (DTC) Detecting Criteria

GENERAL DESCRIPTION

## • 180° Interval Difference Method

Diagnosis value  $domg180 = (omg -1 omg 0) - (omg 7 - omg 1)/6$

Judge misfire occurs in the following cases.

- $domg 180 > \text{judgment value of positive side}$
- $domg 180 \leq \text{judgment value of negative side}$   
(judgment value before 180°CA)

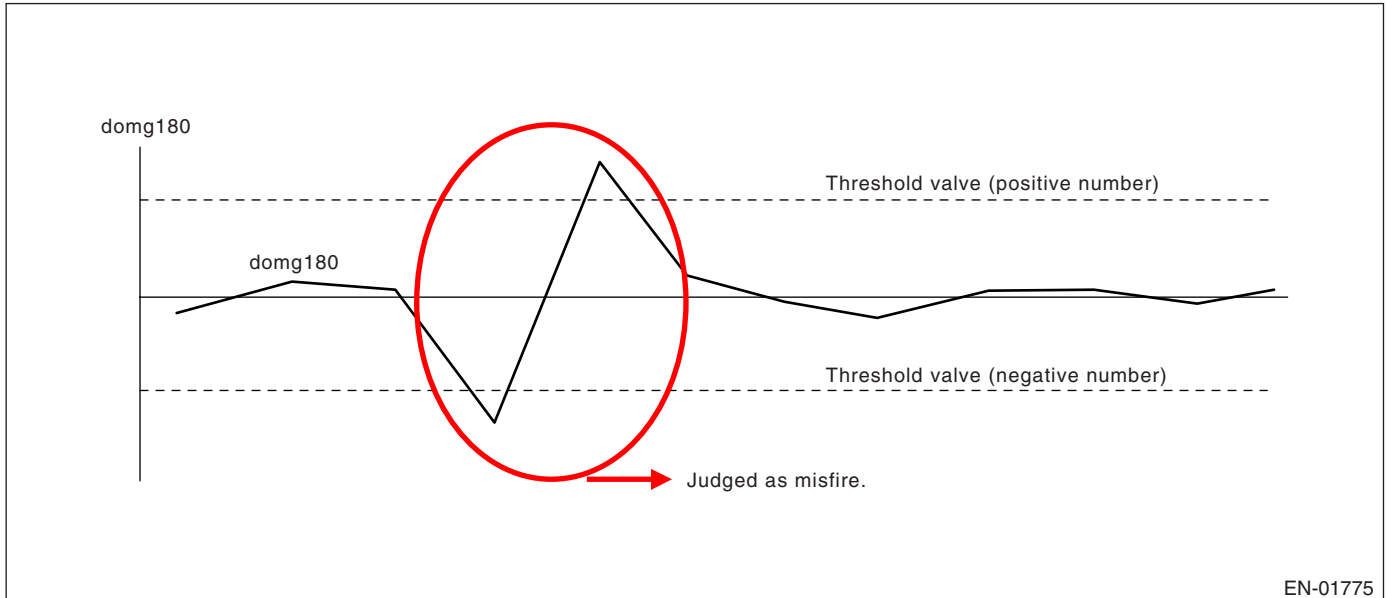

## • 360° Interval Difference Method

Diagnosis value  $domg 360 = (omg 1 - omg 0) - (omg 4 - omg 3)$

Misfire judgment  $domg 360 > \text{judgment value} \rightarrow \text{Misfire occurs}$

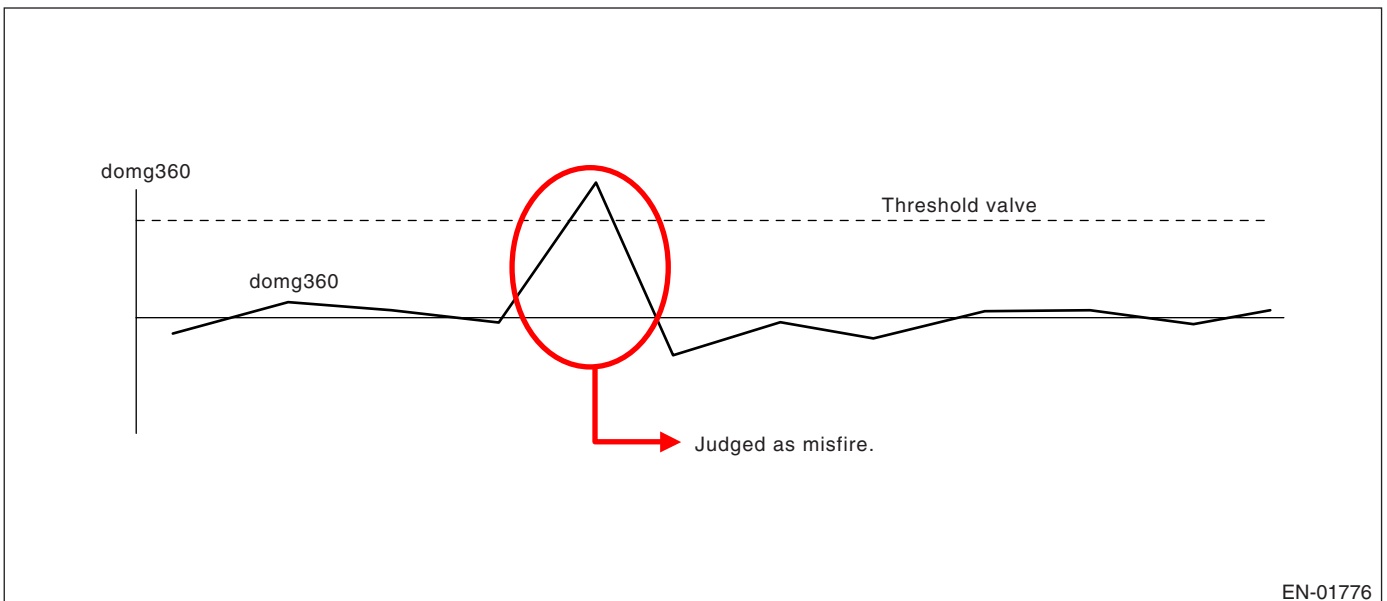

# Diagnostic Trouble Code (DTC) Detecting Criteria

## GENERAL DESCRIPTION

### • 720° Interval Difference Method

Diagnosis value  $domg\ 720 = (omg\ 1 - omg\ 0) - (omg\ 7 - omg\ 6)$   
 Misfire judgment  $domg\ 720 > \text{judgment value} \rightarrow \text{Misfire occurs}$

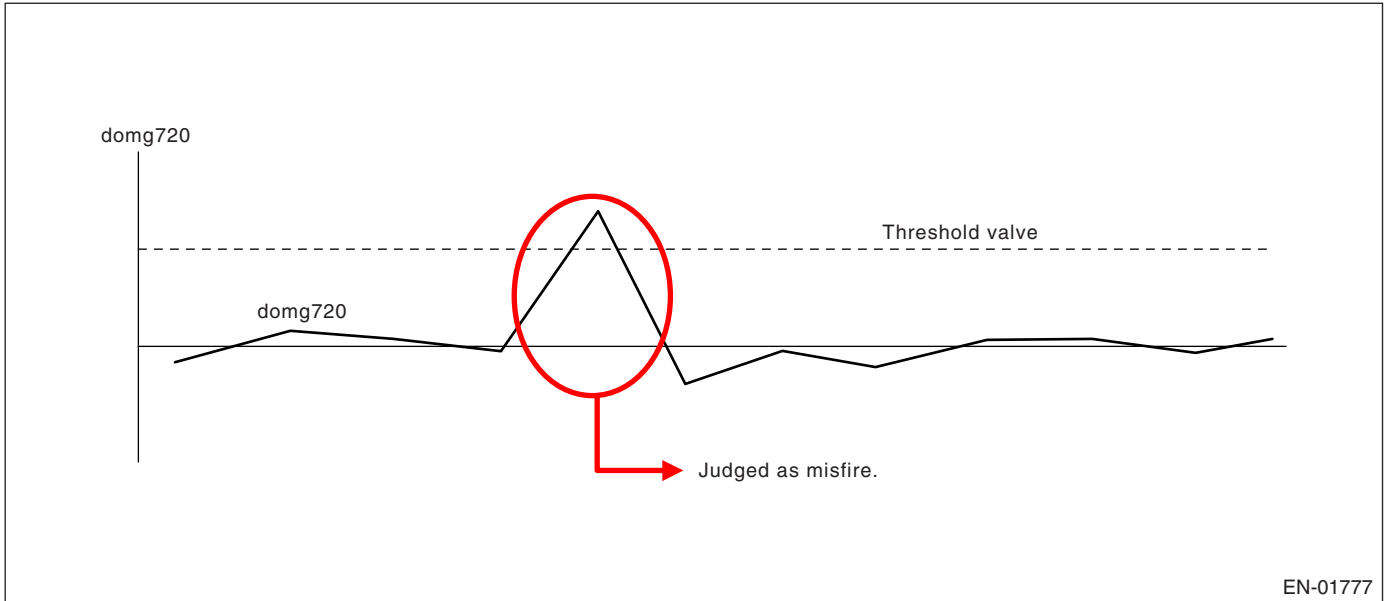

EN-01777

### • FTP 1.5 times misfire (Misfire occurrence level affecting exhaust gas)

**Judgment Value (Judge that malfunction occurs when the misfire ratio is high in 1,000 engine revs.)**

Malfunction Criteria	Threshold Value
FTP emission judgment value	> 1.0% in 1,000 revs.

**Time Needed for Diagnosis:** 1,000 engine revs.

**Malfunction Indicator Light Illumination:** Illuminates when malfunction occurs in 2 continuous driving cycles.

### • Catalyst damage misfire (Misfire occurrence level damaging catalyst)

**Judgment Value (Judge that malfunction occurs when the misfire ratio is high in 200 engine revs. (400 ignitions))**

Malfunction Criteria	Threshold Value
Catalyst damage misfire judgment value	See Map 1

# Diagnostic Trouble Code (DTC) Detecting Criteria

GENERAL DESCRIPTION

Map 1 Fault criteria threshold for misfire which would result in catalyst damage

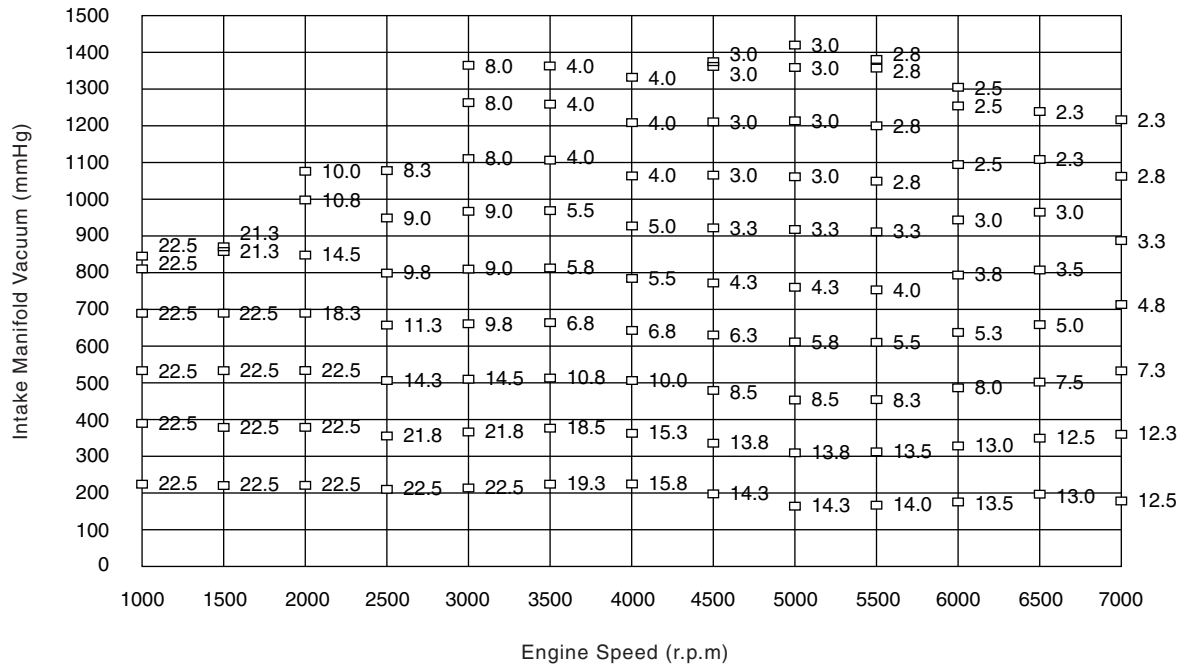

EN-01778

These figures mean the misfire ratio (%) in 400 ignitions; for example, 22.5 (%) means 400 (ignition) × 22.5 (%) = 90 (ignition) or more, so this case is judged misfire.

**Time Needed for Diagnosis:** 200 engine revs.

**Malfunction Indicator Light Illumination:** Illuminates as soon as the malfunction occurs.

## 5. DTC CLEAR CONDITION

- When the OK idling cycle was completed 40 times in a row
- When "Clear Memory" was performed

## 6. MALFUNCTION INDICATOR LIGHT CLEAR CONDITION

- When the OK driving cycle was completed 3 times in a row
- When "Clear Memory" was performed

## 7. FAIL SAFE

None

## Diagnostic Trouble Code (DTC) Detecting Criteria

### GENERAL DESCRIPTION

---

#### 8. ECM OPERATING AT DTC SETTING

Memorize the freeze frame data. (For test mode \$02)

#### **AM:DTC P0302 CYLINDER 2 MISFIRE DETECTED**

NOTE:

For the diagnostic procedure, refer to DTC P0301. <Ref. to GD(H4DOTC)-88, DTC P0301 CYLINDER 1 MISFIRE DETECTED, Diagnostic Trouble Code (DTC) Detecting Criteria.>

#### **AN:DTC P0303 CYLINDER 3 MISFIRE DETECTED**

NOTE:

For the diagnostic procedure, refer to DTC P0301. <Ref. to GD(H4DOTC)-88, DTC P0301 CYLINDER 1 MISFIRE DETECTED, Diagnostic Trouble Code (DTC) Detecting Criteria.>

#### **AO:DTC P0304 CYLINDER 4 MISFIRE DETECTED**

NOTE:

For the diagnostic procedure, refer to DTC P0301. <Ref. to GD(H4DOTC)-88, DTC P0301 CYLINDER 1 MISFIRE DETECTED, Diagnostic Trouble Code (DTC) Detecting Criteria.>

# Diagnostic Trouble Code (DTC) Detecting Criteria

GENERAL DESCRIPTION

## AP:DTC P0327 KNOCK SENSOR 1 CIRCUIT LOW INPUT (BANK 1 OR SINGLE SENSOR)

### 1. OUTLINE OF DIAGNOSIS

Detect the open or short circuit of the knock sensor. Judge NG when out of the standard value.

### 2. COMPONENT DESCRIPTION

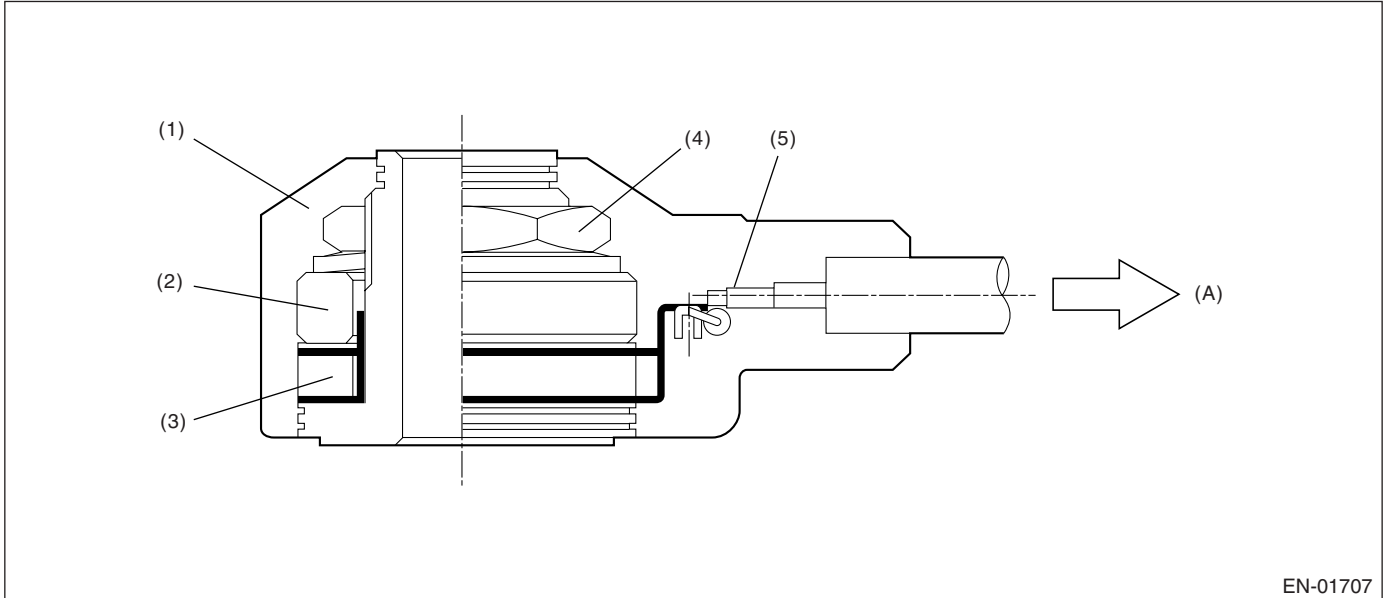

- (1) Case
- (2) Weight
- (3) Piezoelectric element
- (4) Nut
- (5) Resistance

(A) To knock sensor harness

### 3. ENABLE CONDITION

Secondary Parameters	Enable Conditions
None	

### 4. GENERAL DRIVING CYCLE

Always perform the diagnosis continuously.

### 5. DIAGNOSTIC METHOD

#### • Abnormality Judgment

Judge NG when the continuous time of completing the malfunction criteria below becomes more than 1 second.

#### Judgment Value

Malfunction Criteria	Threshold Value
Output voltage	< 0.2 V
Ignition switch	ON

**Time Needed for Diagnosis:** 1 second

**Malfunction Indicator Light Illumination:** Illuminates as soon as the malfunction occurs.



# Diagnostic Trouble Code (DTC) Detecting Criteria

## GENERAL DESCRIPTION

---

### • Normality Judgment

Judge OK and clear NG when the malfunction criteria below are completed.

### Judgment Value

Malfunction Criteria	Threshold Value
Output voltage	$\geq 0.2$ V
Ignition switch	ON

### 6. DTC CLEAR CONDITION

- When the OK idling cycle was completed 40 times in a row
- When "Clear Memory" was performed

### 7. MALFUNCTION INDICATOR LIGHT CLEAR CONDITION

- When the OK driving cycle was completed 3 times in a row
- When "Clear Memory" was performed

### 8. FAIL SAFE

Ignition timing knock correction: Fixed at  $-5^{\circ}\text{CA}$  ( $5^{\circ}\text{CA}$  retarded angle)

### 9. ECM OPERATING AT DTC SETTING

Memorize the freeze frame data. (For test mode \$02)

# Diagnostic Trouble Code (DTC) Detecting Criteria

GENERAL DESCRIPTION

## AQ:DTC P0328 KNOCK SENSOR 1 CIRCUIT HIGH INPUT (BANK 1 OR SINGLE SENSOR)

### 1. OUTLINE OF DIAGNOSIS

Detect the open or short circuit of the knock sensor. Judge NG when out of the standard value.

### 2. COMPONENT DESCRIPTION

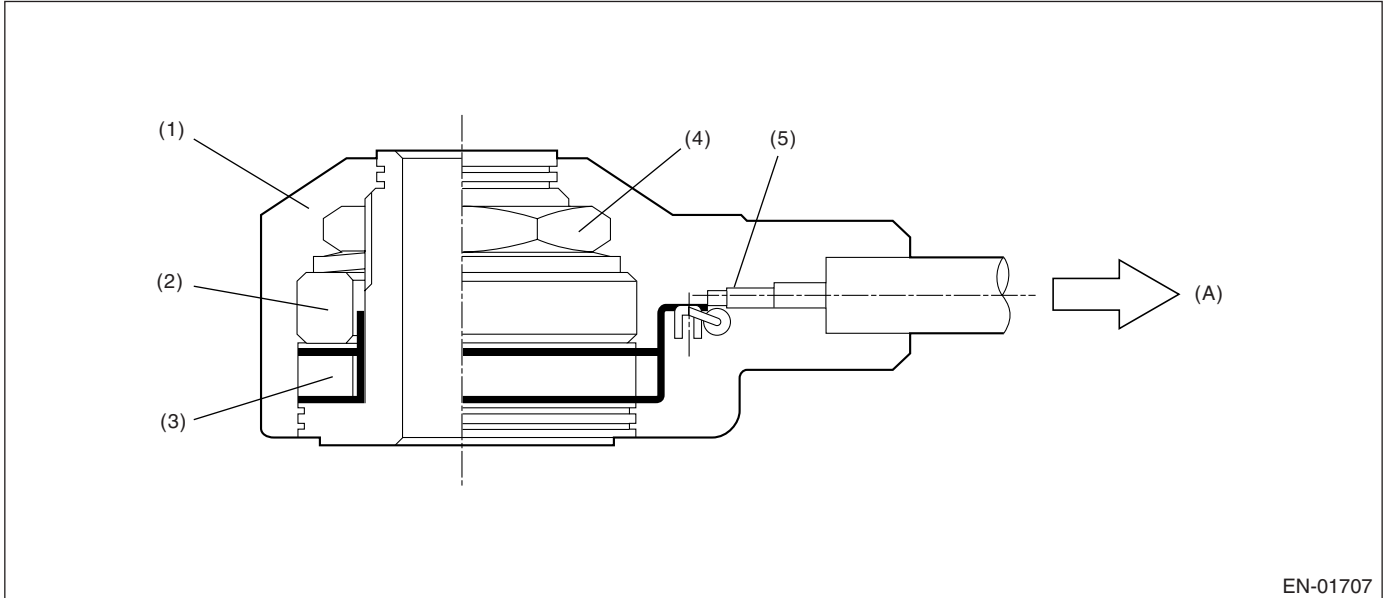

- (1) Case
- (2) Weight
- (3) Piezoelectric element
- (4) Nut
- (5) Resistance

(A) To knock sensor harness

### 3. ENABLE CONDITION

Secondary Parameters	Enable Conditions
None	

### 4. GENERAL DRIVING CYCLE

Always perform diagnosis continuously.

### 5. DIAGNOSTIC METHOD

#### • Abnormality Judgment

Judge NG when the continuous time of completing the malfunction criteria below becomes more than 1 second.

#### Judgment Value

Malfunction Criteria	Threshold Value
Output voltage	$\geq 4.8$ V
Ignition switch	ON

**Time Needed for Diagnosis:** 1 second

**Malfunction Indicator Light Illumination:** Illuminates as soon as the malfunction occurs.

# Diagnostic Trouble Code (DTC) Detecting Criteria

## GENERAL DESCRIPTION

---

### • Normality Judgment

Judge OK and clear NG when the malfunction criteria below are completed.

### Judgment Value

Malfunction Criteria	Threshold Value
Output voltage	< 4.8 V
Ignition switch	ON

### 6. DTC CLEAR CONDITION

- When the OK idling cycle was completed 40 times in a row
- When "Clear Memory" was performed

### 7. MALFUNCTION INDICATOR LIGHT CLEAR CONDITION

- When the OK driving cycle was completed 3 times in a row
- When "Clear Memory" was performed

### 8. FAIL SAFE

Ignition timing knock correction: Fixed at  $-5^{\circ}\text{CA}$  ( $5^{\circ}\text{CA}$  retarded angle)

### 9. ECM OPERATING AT DTC SETTING

Memorize the freeze frame data. (For test mode \$02)

# Diagnostic Trouble Code (DTC) Detecting Criteria

GENERAL DESCRIPTION

## AR:DTC P0335 CRANKSHAFT POSITION SENSOR "A" CIRCUIT

### 1. OUTLINE OF DIAGNOSIS

Detect the open or short circuit of crankshaft position sensor. Judge NG when the crankshaft signal does not input regardless of turning the starter.

### 2. COMPONENT DESCRIPTION

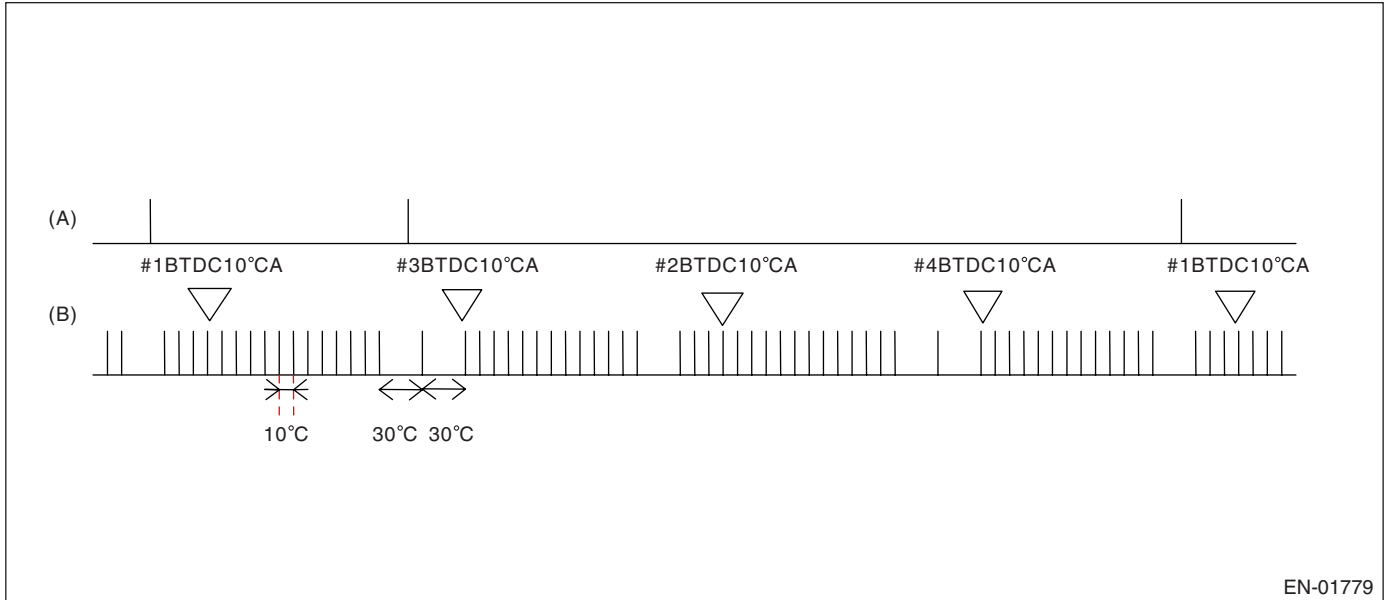

- (A) Camshaft signal
- (B) Crankshaft signal

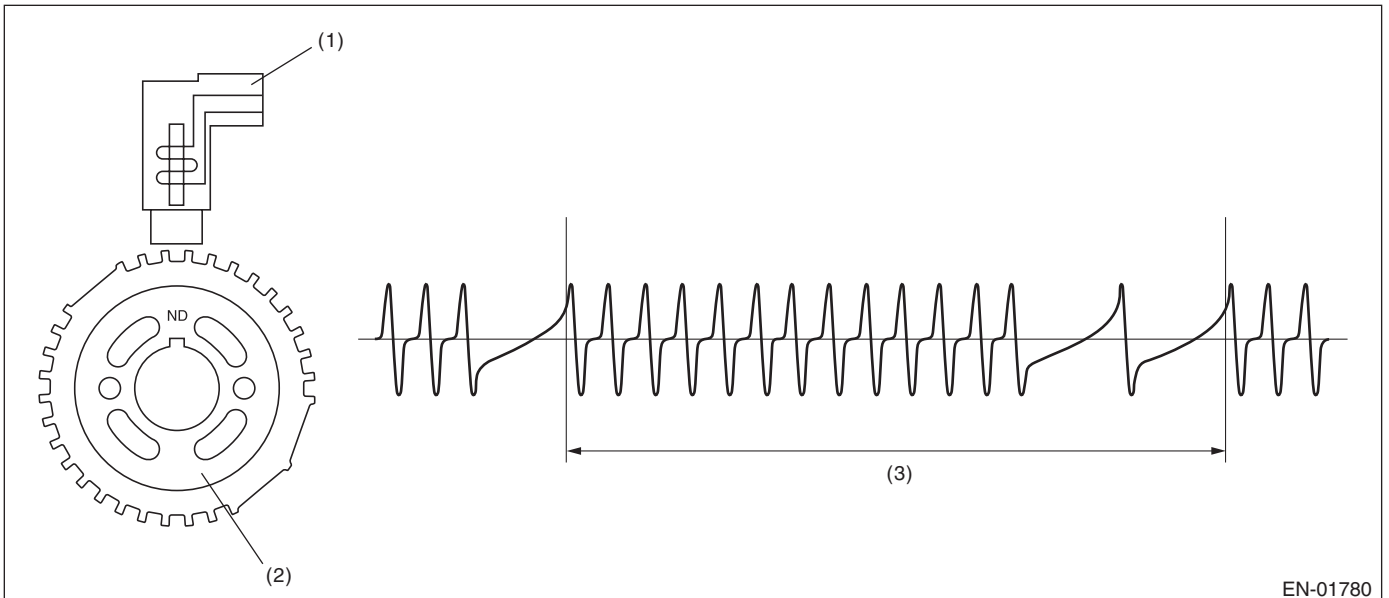

- (1) Crankshaft position sensor
- (2) Crankshaft sprocket
- (3) Crankshaft half-turn

# Diagnostic Trouble Code (DTC) Detecting Criteria

## GENERAL DESCRIPTION

### 3. ENABLE CONDITION

Secondary Parameters	Enable Conditions
None	

### 4. GENERAL DRIVING CYCLE

Always perform the diagnosis continuously.

### 5. DIAGNOSTIC METHOD

#### • Abnormality Judgment

Judge NG when the continuous time of completing the malfunction criteria below becomes more than 3 seconds.

#### Judgment Value

Malfunction Criteria	Threshold Value
Starter switch	ON
Crankshaft position sensor signal	Not detected
Battery voltage	$\geq 8$ V

**Time Needed for Diagnosis:** 3 seconds

**Malfunction Indicator Light Illumination:** Illuminates as soon as the malfunction occurs.

#### • Normality Judgment

Judge OK when the continuous time of completing the malfunction criteria below becomes more than 3 seconds.

#### Judgment Value

Malfunction Criteria	Threshold Value
Crankshaft position sensor signal	Input exists
Battery voltage	$\geq 8$ V

### 6. DTC CLEAR CONDITION

- When the OK idling cycle was completed 40 times in a row
- When "Clear Memory" was performed

### 7. MALFUNCTION INDICATOR LIGHT CLEAR CONDITION

- When the OK driving cycle was completed 3 times in a row
- When "Clear Memory" was performed

### 8. FAIL SAFE

None

### 9. ECM OPERATING AT DTC SETTING

Memorize the freeze frame data. (For test mode \$02)

# Diagnostic Trouble Code (DTC) Detecting Criteria

GENERAL DESCRIPTION

## AS:DTC P0336 CRANKSHAFT POSITION SENSOR "A" CIRCUIT RANGE/PERFORMANCE

### 1. OUTLINE OF DIAGNOSIS

Detect the malfunction of crankshaft position sensor output property. Judge NG when the number of crankshaft signal every 1 revolution becomes abnormal.

### 2. COMPONENT DESCRIPTION

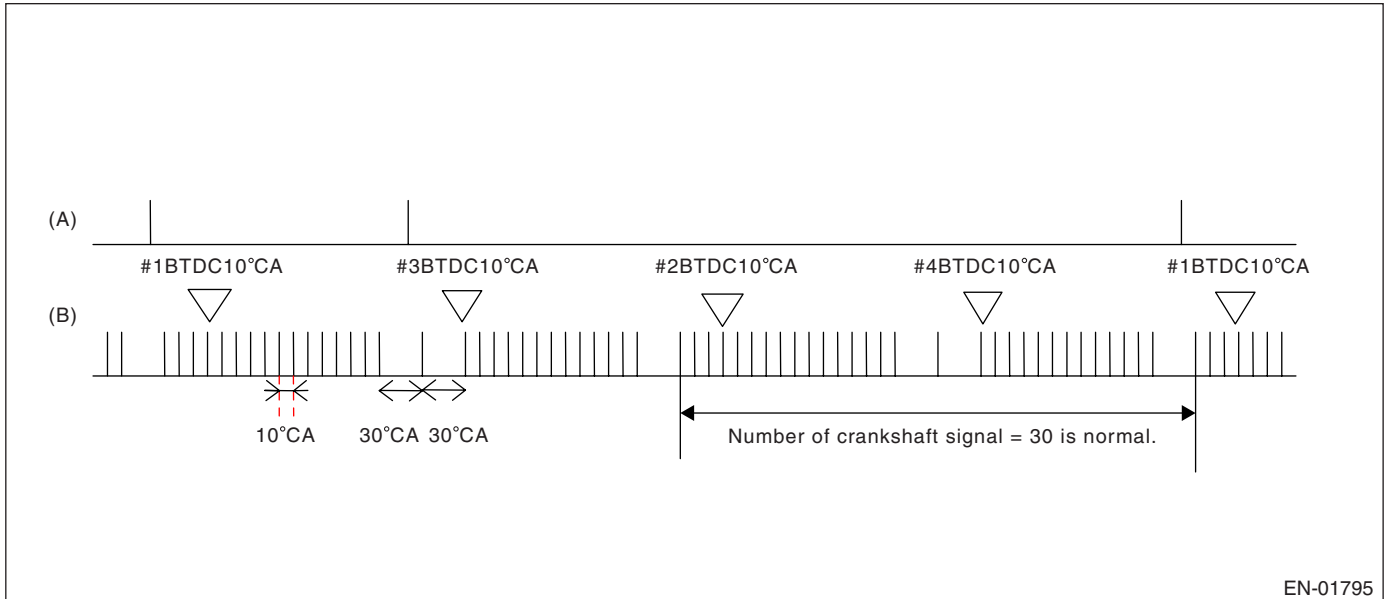

- (A) Camshaft signal
- (B) Crankshaft signal

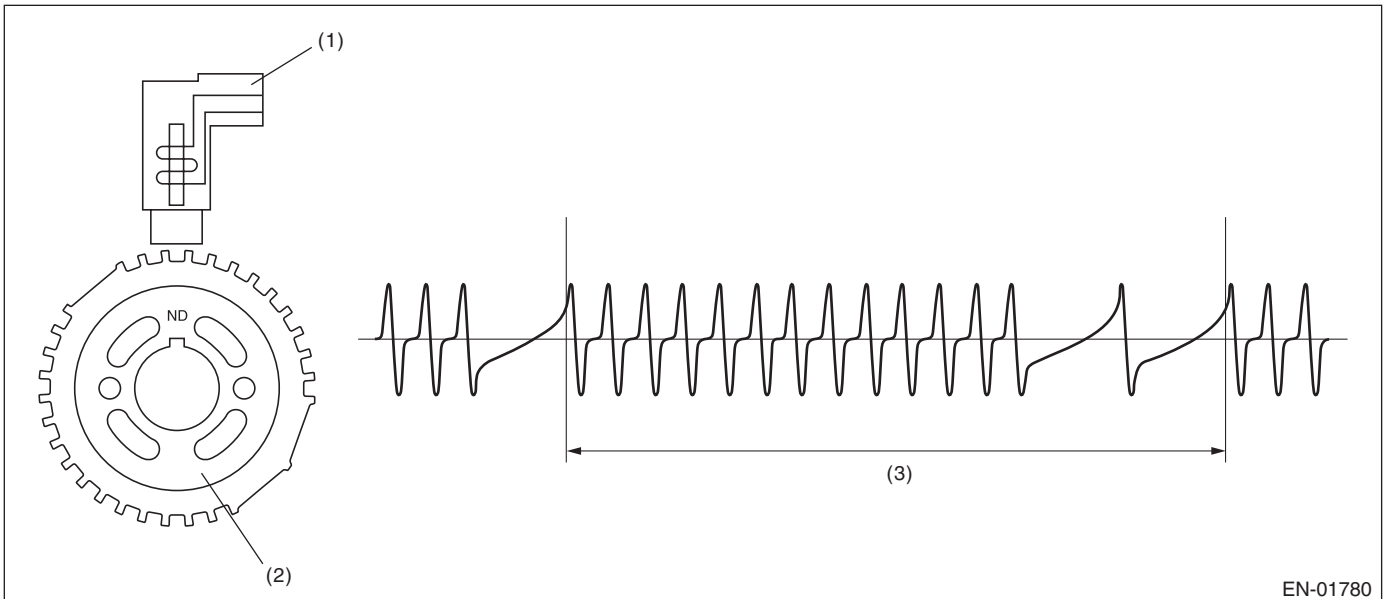

- (1) Crankshaft position sensor
- (2) Crankshaft sprocket
- (3) Crankshaft half-turn

# Diagnostic Trouble Code (DTC) Detecting Criteria

## GENERAL DESCRIPTION

### 3. ENABLE CONDITION

Secondary Parameters	Enable Conditions
Battery voltage	$\geq 8 \text{ V}$
Engine speed	$< 3,000 \text{ rpm}$

### 4. GENERAL DRIVING CYCLE

Perform the diagnosis continuously under 3,000 rpm engine speed.

### 5. DIAGNOSTIC METHOD

#### • Abnormality Judgment

Judge NG when all the malfunction criteria below are completed more than 10 times in a row.

#### Judgment Value

Malfunction Criteria	Threshold Value
Cylinder number distinction	Completed
Amount of crank sensor signal during 1 rev.	Not = 30

**Time Needed for Diagnosis:** 10 engine revs.

**Malfunction Indicator Light Illumination:** Illuminates when malfunction occurs in 2 continuous driving cycles.

#### • Normality Judgment

Judge OK and clear the NG when the malfunction criteria below are completed.

#### Judgment Value

Malfunction Criteria	Threshold Value
Cylinder number distinction	Completed
Amount of crank sensor signal during 1 rev.	= 30

### 6. DTC CLEAR CONDITION

- When the OK idling cycle was completed 40 times in a row
- When "Clear Memory" was performed

### 7. MALFUNCTION INDICATOR LIGHT CLEAR CONDITION

- When the OK driving cycle was completed 3 times in a row
- When "Clear Memory" was performed

### 8. FAIL SAFE

None

### 9. ECM OPERATING AT DTC SETTING

Memorize the freeze frame data. (For test mode \$02)

# Diagnostic Trouble Code (DTC) Detecting Criteria

GENERAL DESCRIPTION

## AT:DTC P0340 CAMSHAFT POSITION SENSOR "A" CIRCUIT (BANK 1 OR SINGLE SENSOR)

### 1. OUTLINE OF DIAGNOSIS

Detect the open or short circuit of camshaft position sensor. Judge NG when the number of camshaft signal remains to be abnormal.

### 2. COMPONENT DESCRIPTION

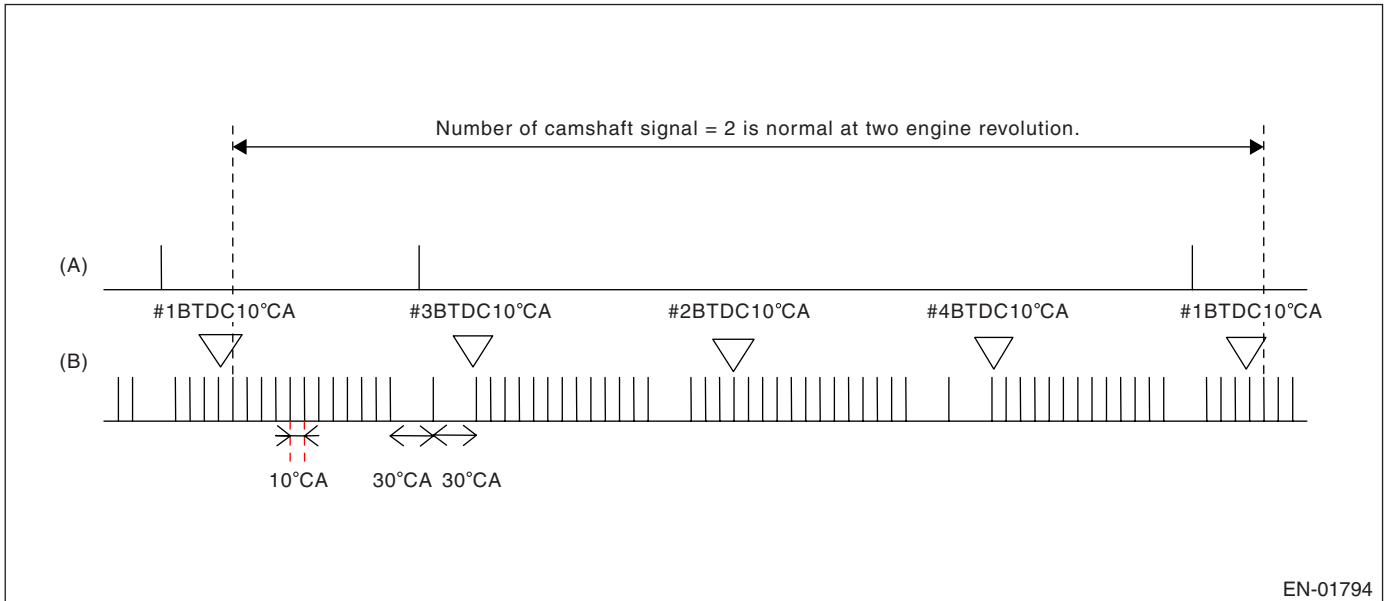

- (A) Camshaft signal
- (B) Crankshaft signal

EN-01794



# Diagnostic Trouble Code (DTC) Detecting Criteria

## GENERAL DESCRIPTION

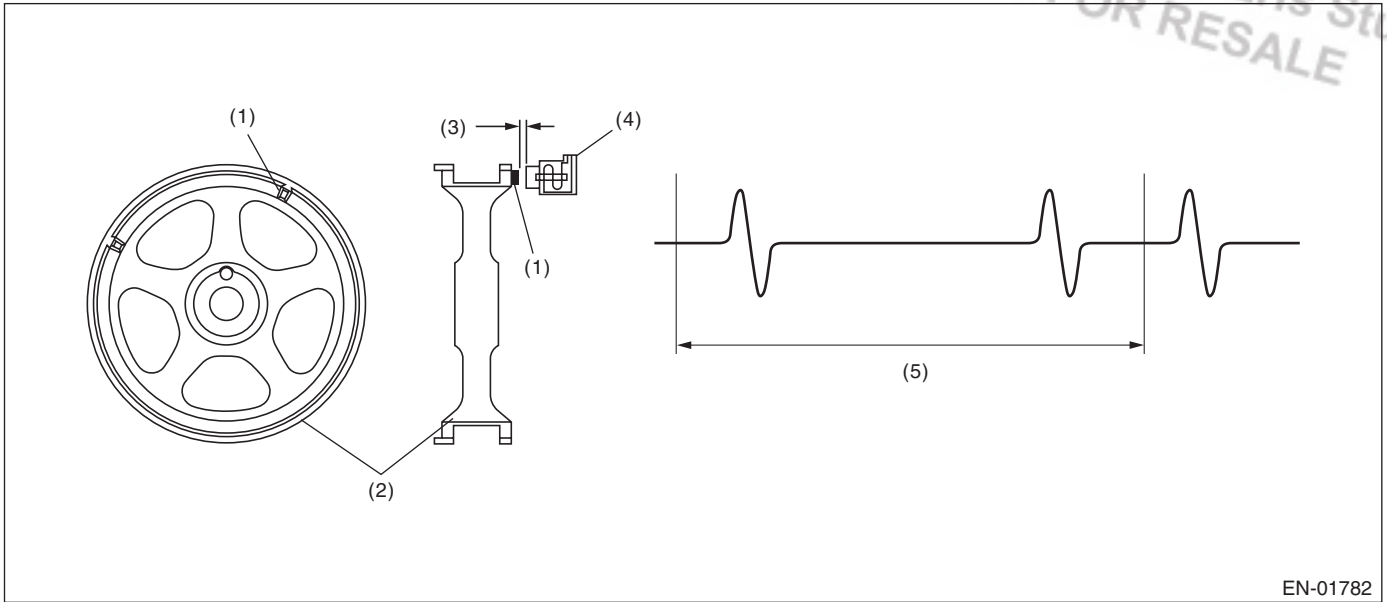

- (1) Boss
- (2) Camshaft sprocket
- (3) Air gap
- (4) Camshaft position sensor
- (5) Camshaft one revolution (Engine two revolutions)

### 3. ENABLE CONDITION

Secondary Parameters	Enable Conditions
None	

### 4. GENERAL DRIVING CYCLE

Always perform the diagnosis continuously.

### 5. DIAGNOSTIC METHOD

#### • Abnormality Judgment

Judge NG when the engine speed continues more than 8 revolutions.

#### Judgment Value

Malfunction Criteria	Threshold Value
Battery voltage	$\geq 8 \text{ V}$
Amount of camshaft sensor signal during 2 revs.	$\neq 2$

**Time Needed for Diagnosis:** 8 revs.

**Malfunction Indicator Light Illumination:** Illuminates as soon as the malfunction occurs.

#### • Normality Judgment

Judge OK and clear the NG when the malfunction criteria below are completed.

#### Judgment Value

Malfunction Criteria	Threshold Value
Battery voltage	$\geq 8 \text{ V}$
Amount of camshaft sensor signal during 2 revs.	$= 2$

## Diagnostic Trouble Code (DTC) Detecting Criteria

GENERAL DESCRIPTION

### 6. DTC CLEAR CONDITION

- When the OK idling cycle was completed 40 times in a row
- When "Clear Memory" was performed

### 7. MALFUNCTION INDICATOR LIGHT CLEAR CONDITION

- When the OK driving cycle was completed 3 times in a row
- When "Clear Memory" was performed

### 8. FAIL SAFE

None

### 9. ECM OPERATING AT DTC SETTING

Memorize the freeze frame data. (For test mode \$02)

# Diagnostic Trouble Code (DTC) Detecting Criteria

## GENERAL DESCRIPTION

### AU:DTC P0341 CAMSHAFT POSITION SENSOR "A" CIRCUIT RANGE/PERFORMANCE (BANK 1 OR SINGLE SENSOR)

#### 1. OUTLINE OF DIAGNOSIS

Detect the malfunction of camshaft position sensor output property. Judge NG when the camshaft line signal input timing is shifted from the crankshaft signal because of timing belt tooth chip, etc.

#### 2. COMPONENT DESCRIPTION

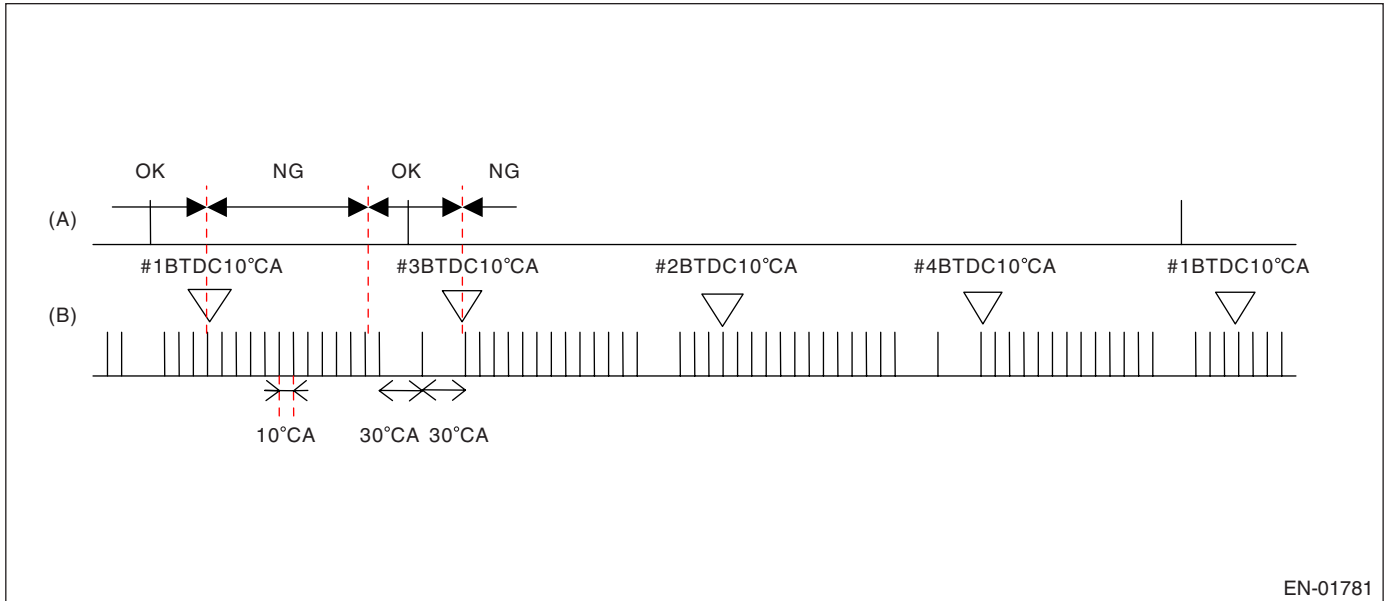

- (A) Camshaft signal
- (B) Crankshaft signal

EN-01781

# Diagnostic Trouble Code (DTC) Detecting Criteria

GENERAL DESCRIPTION

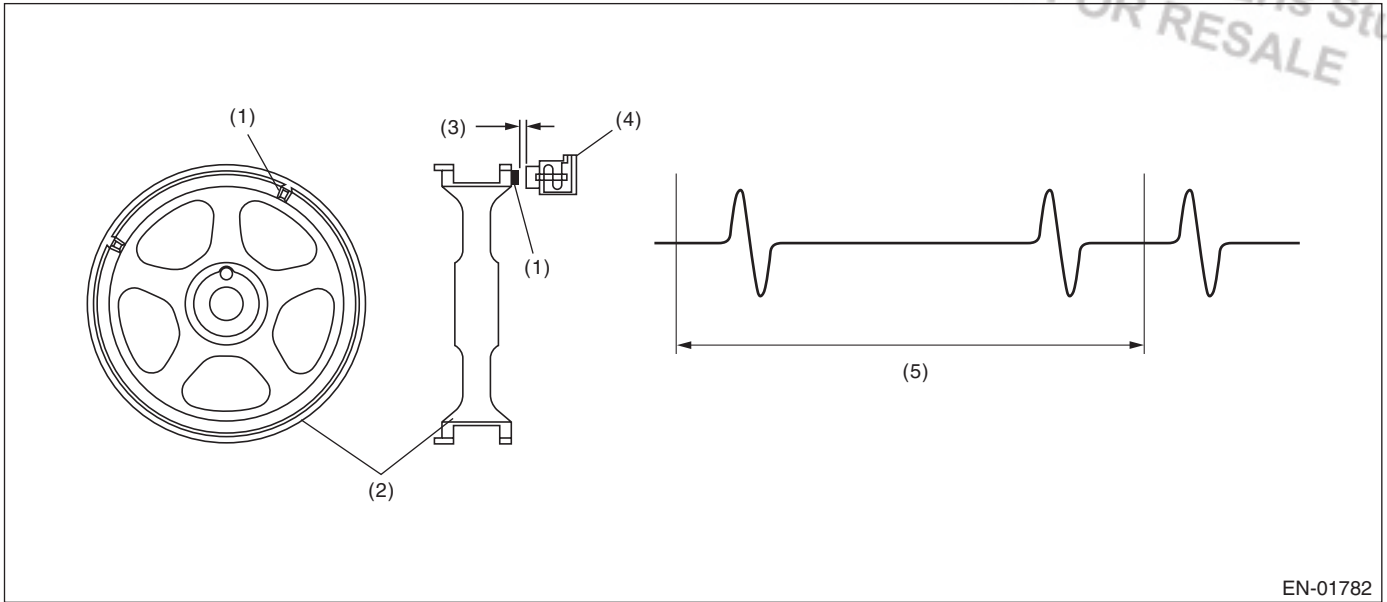

EN-01782

- (1) Boss
- (2) Camshaft sprocket
- (3) Air gap
- (4) Camshaft position sensor
- (5) Camshaft one revolution (Engine two revolutions)

## 3. ENABLE CONDITION

Secondary Parameters	Enable Conditions
Cylinder number distinction	Completed
Battery voltage	$\geq 8 \text{ V}$
Engine speed	550 $\leftrightarrow$ 1,000 rpm
Engine operation	In idle
Misfire	Not detect

## 4. GENERAL DRIVING CYCLE

Perform the diagnosis at idling continuously.

## 5. DIAGNOSTIC METHOD

Judge NG when the engine speed continues 5 revolutions for the malfunction criteria below. Judge OK and clear the NG when the malfunction criteria below are not completed.

### Judgment Value

Malfunction Criteria	Threshold Value
Position of camshaft position sensor signal	Not between BTDC 10°CA and BTDC 80°CA

**Time Needed for Diagnosis:** 5 revs.

**Malfunction Indicator Light Illumination:** Illuminates when malfunction occurs in 2 continuous driving cycles.

## 6. DTC CLEAR CONDITION

- When the OK idling cycle was completed 40 times in a row
- When "Clear Memory" was performed

## Diagnostic Trouble Code (DTC) Detecting Criteria

### GENERAL DESCRIPTION

---

#### 7. MALFUNCTION INDICATOR LIGHT CLEAR CONDITION

- When the OK driving cycle was completed 3 times in a row
- When "Clear Memory" was performed

#### 8. FAIL SAFE

None

#### 9. ECM OPERATING AT DTC SETTING

Memorize the freeze frame data. (For test mode \$02)

# Diagnostic Trouble Code (DTC) Detecting Criteria

GENERAL DESCRIPTION

## AV:DTC P0420 CATALYST SYSTEM EFFICIENCY BELOW THRESHOLD (BANK 1)

### 1. OUTLINE OF DIAGNOSIS

Detect the deterioration of catalyst function.

Though the rear oxygen sensor output would change slowly with a new catalyst, the sensor output with a deteriorated catalyst becomes high and the inversion time is shortened. For this reason, the catalyst diagnosis is carried out by monitoring the rear oxygen sensor output and comparing it with the front A/F sensor output.

### 2. COMPONENT DESCRIPTION

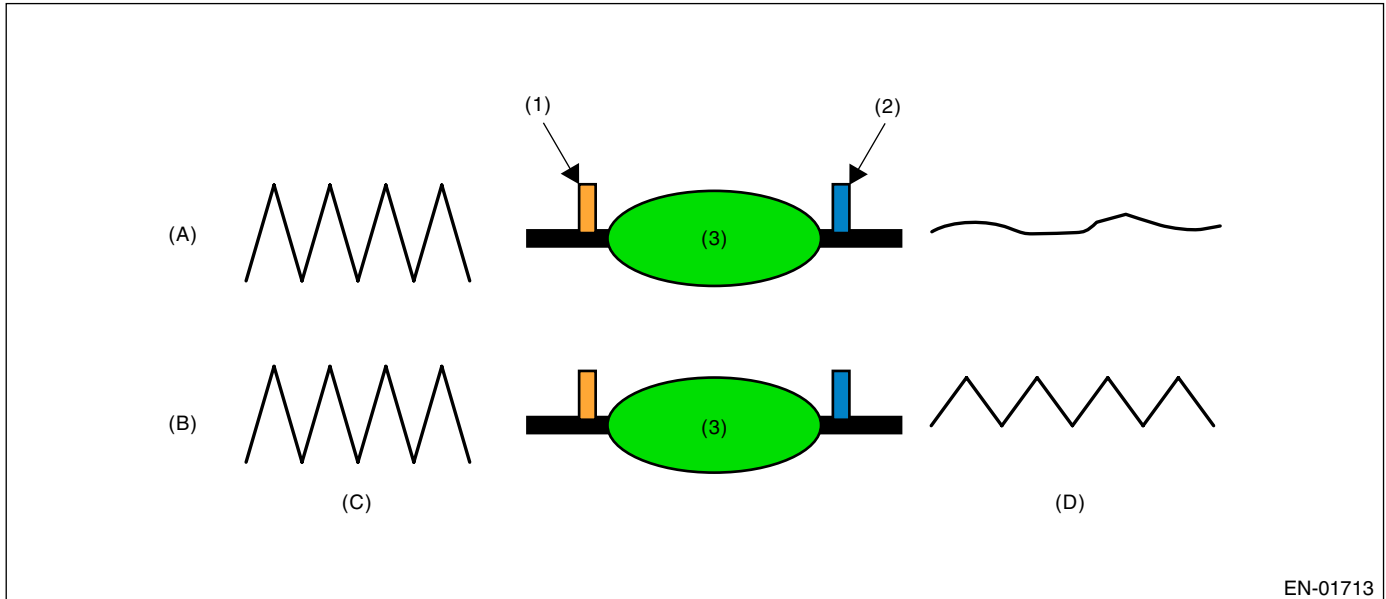

- (1) Front oxygen (A/F) sensor
- (2) Rear oxygen sensor
- (3) Catalyst

- (A) Normal
- (B) Deterioration
- (C) Front oxygen (A/F) sensor waveform
- (D) Rear oxygen sensor waveform

EN-01713

# Diagnostic Trouble Code (DTC) Detecting Criteria

## GENERAL DESCRIPTION

### 3. ENABLE CONDITION

Secondary Parameters	Enable Conditions
Time for keep completing all secondary parameters	1.2 seconds or more
Catalyst deterioration diagnosis	Not finished
Battery voltage	> 10.9 V
Atmospheric pressure	> 75.1 kPa (563 mmHg, 22.2 inHg)
Engine coolant temperature	≥ 65°C (149°F)
Catalyst warm-up counter on Map 2	≥ 7,600
Misfire detection during 200 engine revs.	< 5 times
Learning value of evaporation gas density	< 0.20
Sub feedback	Operating
Evaporative system diagnostic	Not in operation
Difference between actual and target time lambda < 0.10	1,000 milliseconds or more
Vehicle speed	≥ 75 km/h (46.6 MPH)
Engine speed	1,600 ↔ 3,500 rpm
Amount of intake air	10 ↔ 36 g/s
Engine load change every 0.5 engine revs.	< 0.03 g/rev
Rear O <sub>2</sub> output change from below 600 mV to over	Experienced after fuel cut

#### • Map 2

Add the following value every 524.288 milliseconds.

#### Catalyst warm-up counter ≤ 7,500

Amount of intake air (g/s)	0	4.7	9.4	14.1	18.8	23.4	28.1	32.8	37.5	42.2	46.9	51.6
Integrated value for warm-up counter	-15.7	-1	15.9	31.7	47.5	63.3	79.1	94.8	111	126	126	126

#### Catalyst warm-up counter > 7,500

Amount of intake air (g/s)	0	4.7	9.4	14.1	18.8	23.4	28.1	32.8	37.5	42.2	46.9	51.6
Integrated value for warm-up counter	-5.3	-2	6.3	8.4	9.9	11.0	12.0	12.8	13.5	14.1	14.6	15.1

### 4. GENERAL DRIVING CYCLE

Perform the diagnosis once at the constant vehicle speed from 80 to 100 km/h (49.7 to 62.1 MPH).

### 5. DIAGNOSTIC METHOD

After the malfunction criterias are completed, calculate the output fluctuation value of front oxygen (A/F) sensor and output fluctuation value of rear oxygen sensor.

Calculate the diagnosis value when the front oxygen (A/F) sensor output fluctuation value more than specified value.

Regard the A/F response properties and diagnosis value as parameters for judgment value.

Judge NG when the malfunction criteria below are completed, and judge OK when they are not completed.

# Diagnostic Trouble Code (DTC) Detecting Criteria

GENERAL DESCRIPTION

## Judgment Value

Malfunction Criteria	Threshold Value
Accumulated variation of output voltage of rear oxygen sensor per 32 milliseconds $\times$ 4 divided by accumulated variation of lambda of front oxygen (A/F) sensor per 32 milliseconds $\times$ 4	$\geq$ Map 3

## Map 3

Diagnosis value	0.15	0.2	0.25	0.3
Judgment value	4	6.5	9	12

**Time Needed for Diagnosis:** 20 seconds

**Malfunction Indicator Light Illumination:** Illuminates when malfunction occurs in 2 continuous driving cycles.

## 6. DTC CLEAR CONDITION

- When the OK idling cycle was completed 40 times in a row
- When "Clear Memory" was performed

## 7. MALFUNCTION INDICATOR LIGHT CLEAR CONDITION

- When the OK driving cycle was completed 3 times in a row
- When "Clear Memory" was performed

## 8. FAIL SAFE

None

## 9. ECM OPERATION AT DTC SETTING

- Memorize the freeze frame data. (For test mode \$02)
- Memorize the diagnostic value and trouble standard value. (For test mode \$06)



# Diagnostic Trouble Code (DTC) Detecting Criteria

## GENERAL DESCRIPTION

### AW:DTC P0442 EVAPORATIVE EMISSION CONTROL SYSTEM LEAK DETECTED (SMALL LEAK)

#### 1. OUTLINE OF DIAGNOSIS

Perform the diagnosis of leakage of fuels system and valve functions.

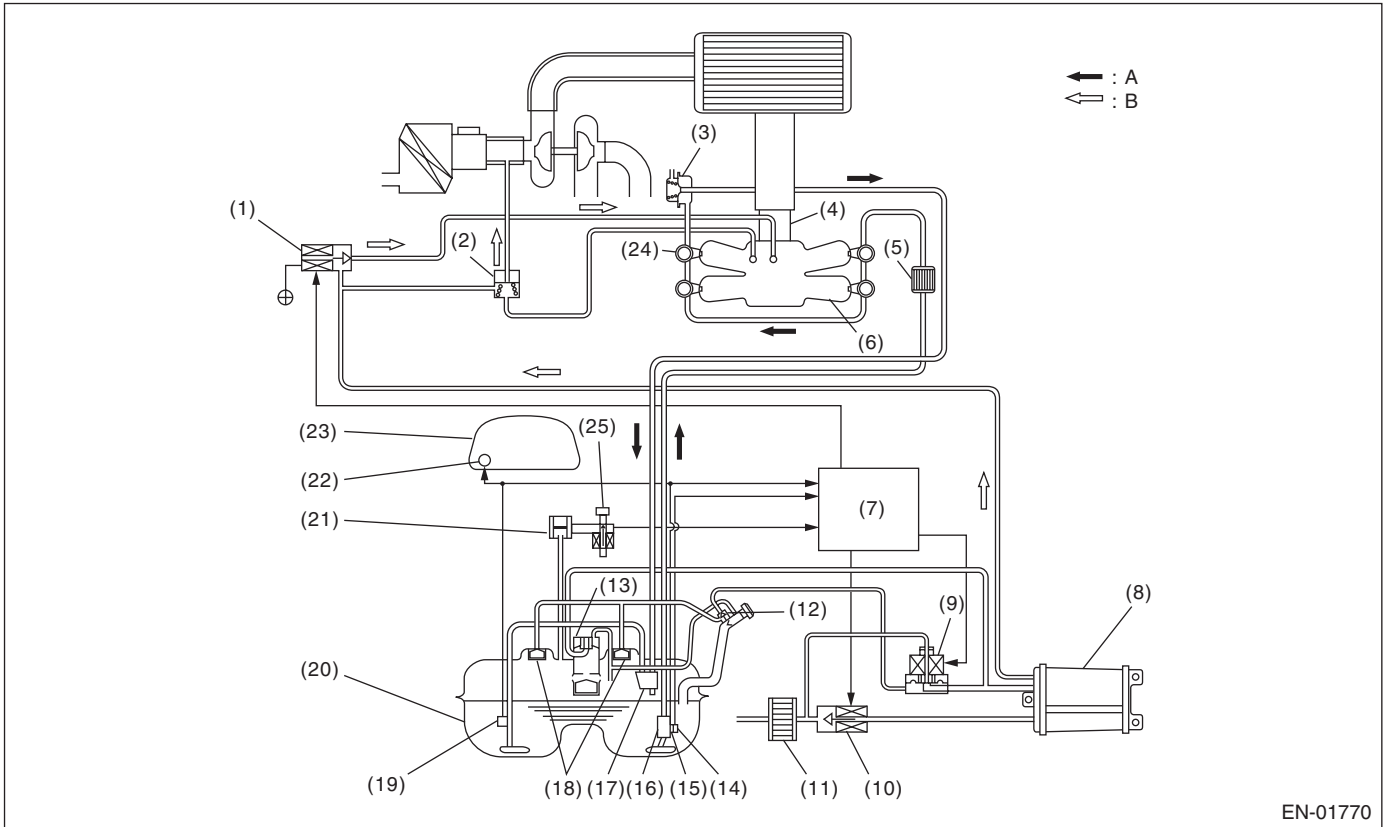

- |                                     |   |
|-------------------------------------|---|
| (1) Purge control solenoid valve    | (14) Fuel temperature sensor                |
| (2) Purge valve                     | (15) Fuel level sensor                      |
| (3) Pressure regulator              | (16) Fuel pump                              |
| (4) Throttle body                   | (17) Jet pump                               |
| (5) Fuel filter                     | (18) Fuel cut valve                         |
| (6) Intake manifold                 | (19) Fuel sub level sensor                  |
| (7) Engine control module (ECM)     | (20) Fuel tank                              |
| (8) Canister                        | (21) Fuel tank pressure sensor              |
| (9) Pressure control solenoid valve | (22) Fuel meter                             |
| (10) Drain valve                    | (23) Combination meter                      |
| (11) Drain filter                   | (24) Fuel injector                          |
| (12) Shut-off valve                 | (25) Tank pressure switching solenoid valve |
| (13) Vent valve                     |   |

# Diagnostic Trouble Code (DTC) Detecting Criteria

GENERAL DESCRIPTION

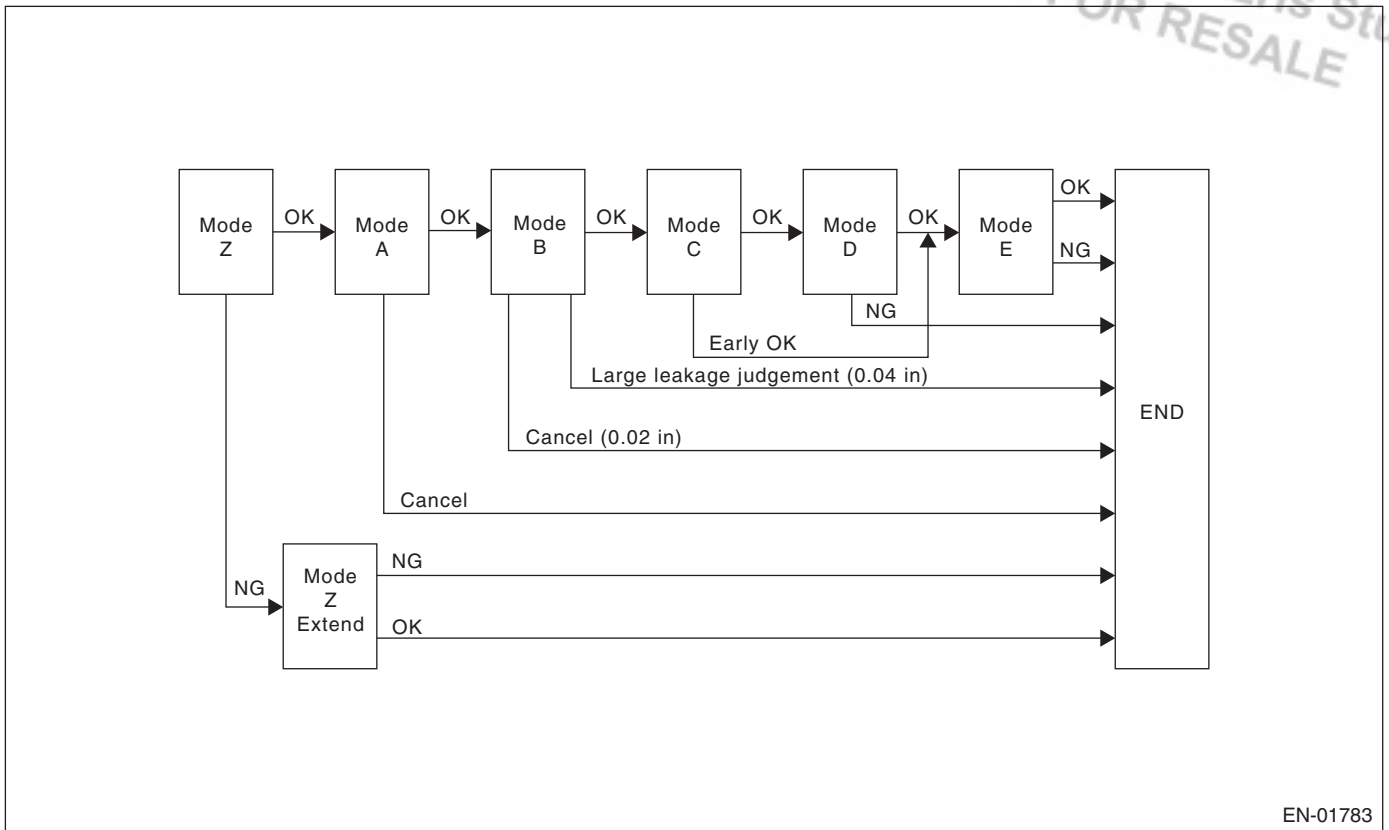

EN-01783

In this system diagnosis, filter tank pressure is changed. And leakage and normality & abnormality of valve operation are judged by monitoring the pressure change status using the fuel tank pressure sensor. The diagnosis is performed in the order of Z (0.04-inch diagnosis only), Mode A, Mode B, Mode C, Mode D and Mode E.

## 0.04-inch Diagnosis

Mode	Mode Description	Diagnosis Period
Mode Z (Purge control solenoid valve open fail diagnosis/drain valve closed fail diagnosis)	Perform the diagnosis of purge control solenoid valve open fail and drain valve closed fail depending on the magnitude of the tank pressure change after diagnosis started.	3 — 16 seconds
Mode A (Evaluation of EVAP. generation amount)	Calculate the tank pressure change amount (P1).	16 seconds
Mode B (Negative pressure sealed/large leak judgment)	Introduce the intake manifold pressure into the fuel tank. If the tank pressure cannot be reduced, diagnose that there is large leakage.	4 — 35 seconds
Mode C (Pressure increase check/premature OK judgment)	Wait until the tank pressure returns to the target value. If the pressure does not return, perform the premature OK judgment.	4 — 15 seconds
Mode D (Negative pressure change amount measurement/EVAP. leakage diagnosis)	Calculate the tank pressure change amount (P2), and measure the diagnosis value using P1 calculated in Mode A. Perform the EVAP. leakage diagnosis using the diagnosis value.	12 — 16 seconds
Mode E (Drain valve property abnormality diagnosis)	Perform the drain valve property abnormality diagnosis depending on the magnitude of the tank pressure change after the leakage diagnosis completed.	4 seconds

# Diagnostic Trouble Code (DTC) Detecting Criteria

## GENERAL DESCRIPTION

### 0.02-inch Diagnosis

Mode	Mode Description	Diagnosis Period
Mode A (Evaluation of EVAP. generation amount)	Calculate the tank pressure change amount (P1).	29 seconds
Mode B (Negative pressure seal)	Introduce the intake manifold pressure into the fuel tank, and reduce the tank pressure to the target pressure.	10 — 20 seconds
Mode C (Pressure increase check/premature OK judgment)	Wait until the tank pressure returns to the target value. If the tank pressure does not return, perform the premature OK judgment.	5 — 20 seconds
Mode D (Negative pressure change amount measurement/EVAP. leakage diagnosis)	Calculate the tank pressure change value (P2), measure the diagnosis value using P1 calculated in Mode A. Perform the EVAP. leakage diagnosis using the diagnosis value.	20 — 25 seconds
Mode E (Drain valve property abnormality diagnosis)	Perform the drain valve property abnormality diagnosis depending on the magnitude of the tank pressure change after the leakage diagnosis completed.	4 seconds

### Mode table for Evaporative Emission Control System diagnosis

Mode	Normal conditions	Diagnostic item	DTC
Mode Z	Nearly same as atmospheric pressure (equivalent pressure of 0 kPa (0 mmHg, 0 inHg))	CCV is judged to be stuck closed.	P1443
		CPC is judged to be stuck open.	P0457
Mode A	Pressure is in proportion to amount of evaporative emission.	—	—
Mode B	Negative pressure is formed due to intake manifold negative pressure	Judged as large leak	P0457
Mode C	Target pressure is reached.	—	—
Mode D	Pressure change is small.	EVAP system is judged to have large leak [1.0 mm (0.04 in.)].	P0442
		EVAP system is judged to have small leak [0.5 mm (0.02 in.)].	P0456
Mode E	Return to atmospheric pressure	CCV property	P1443

# Diagnostic Trouble Code (DTC) Detecting Criteria

GENERAL DESCRIPTION

## 2. COMPONENT DESCRIPTION

### • Pressure Control Solenoid Valve

Pressure control solenoid valve maintains the fuel tank pressure equal to the atmospheric air pressure. Normally, the solenoid is set to OFF, and the valve mechanically opens and closes in accordance with the difference between the tank pressure and atmospheric air pressure, and the tank pressure and canister pressure.

The solenoid which is set to ON forces to open the valve.

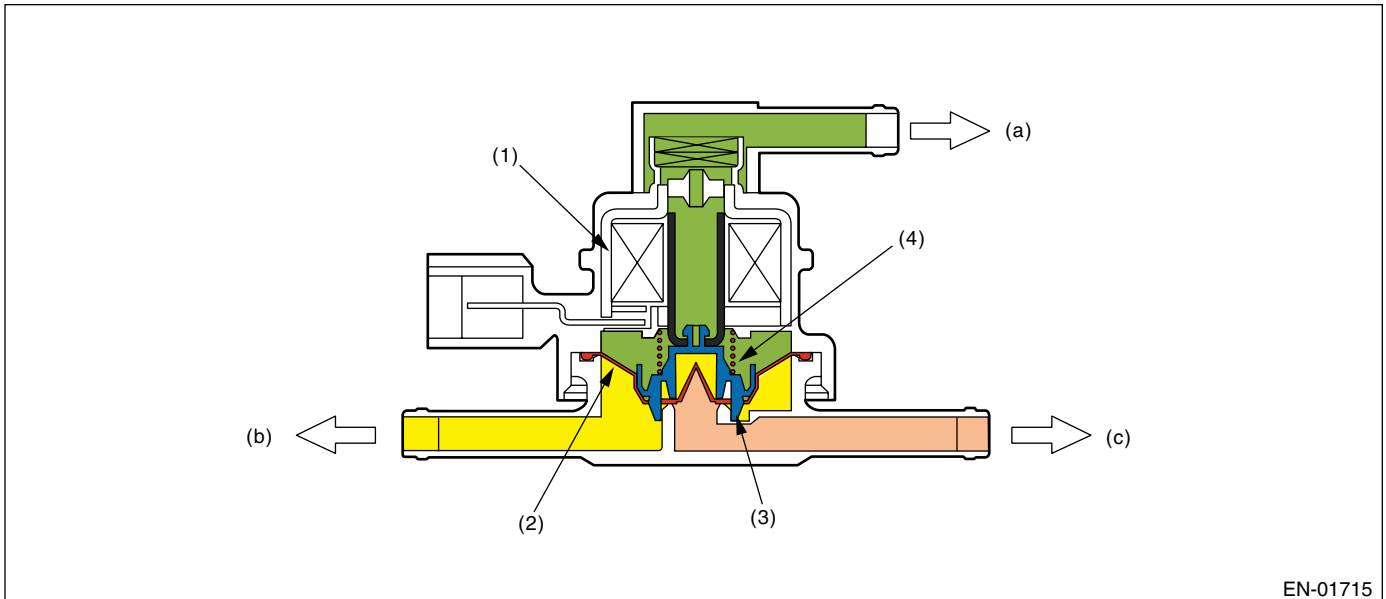

- (1) Solenoid
- (2) Diaphragm
- (3) Valve
- (4) Spring

- (a) Atmospheric pressure
- (b) Fuel tank
- (c) Canister

# Diagnostic Trouble Code (DTC) Detecting Criteria

## GENERAL DESCRIPTION

### • Valve Operation and Air Flow

As in the X parts below, there are the area with atmospheric air pressure above the diaphragm and the area with tank pressure below the diaphragm. Also, as in the Y parts below, there are the area with tank pressure above the diaphragm and the area with canister pressure below the diaphragm. In the table below the air flow from each port in accordance with pressure difference is shown with the atmospheric air pressure port A, tank pressure port B and canister pressure port C.

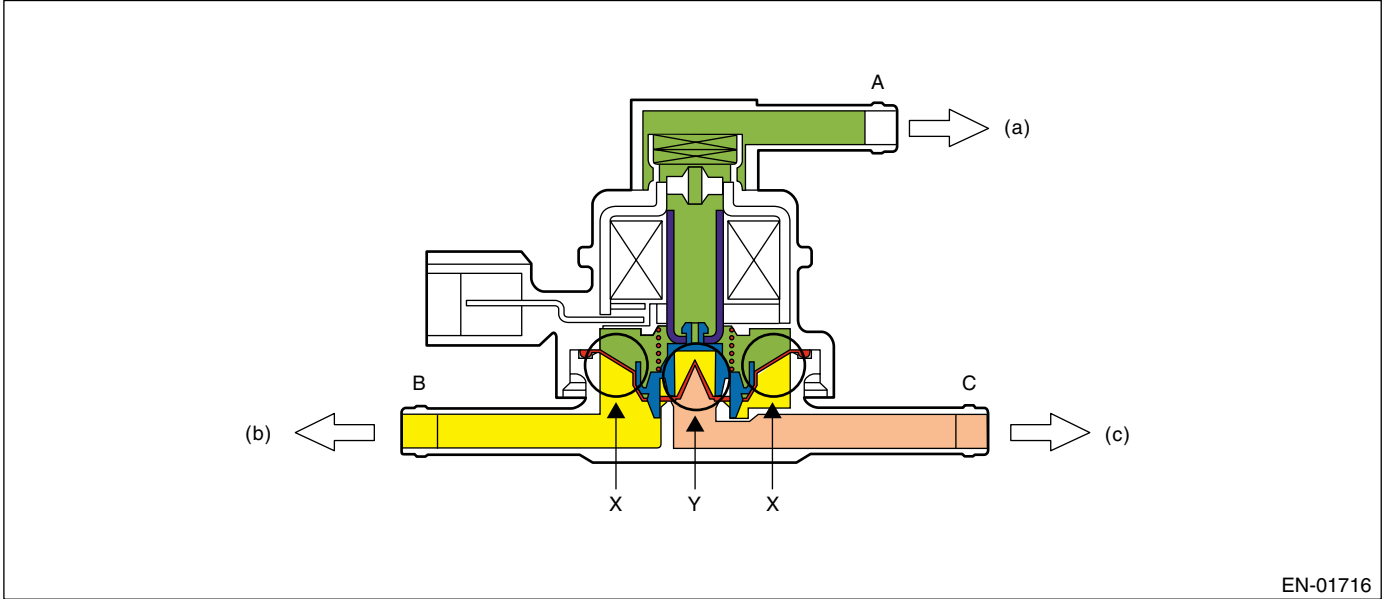

- (a) Atmospheric pressure
- (b) Fuel tank
- (c) Canister

Pressure Status	Flow
$A < B$ (Solenoid OFF)	$B \rightarrow C$
$B < C$ (Solenoid OFF)	$C \rightarrow B$
Solenoid ON	$B \leftrightarrow C$

# Diagnostic Trouble Code (DTC) Detecting Criteria

GENERAL DESCRIPTION

## When $A < B$ (Solenoid OFF)

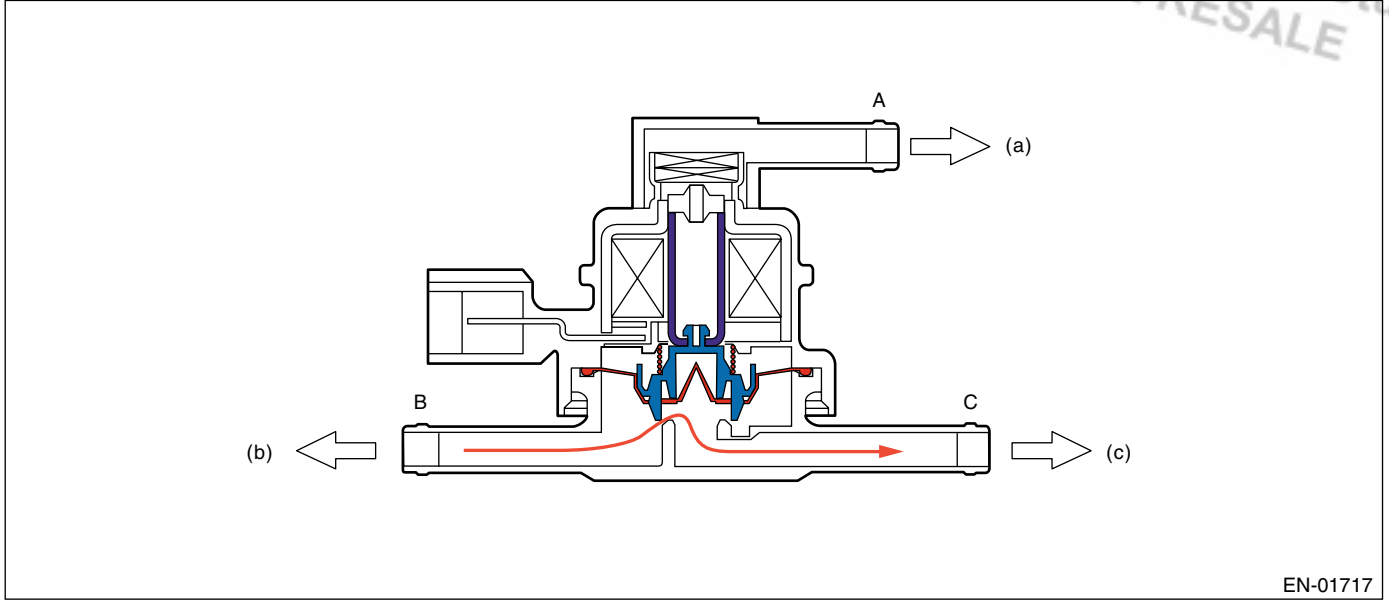

- (a) Atmospheric pressure
- (b) Fuel tank
- (c) Canister

## When $B < C$ (Solenoid OFF)

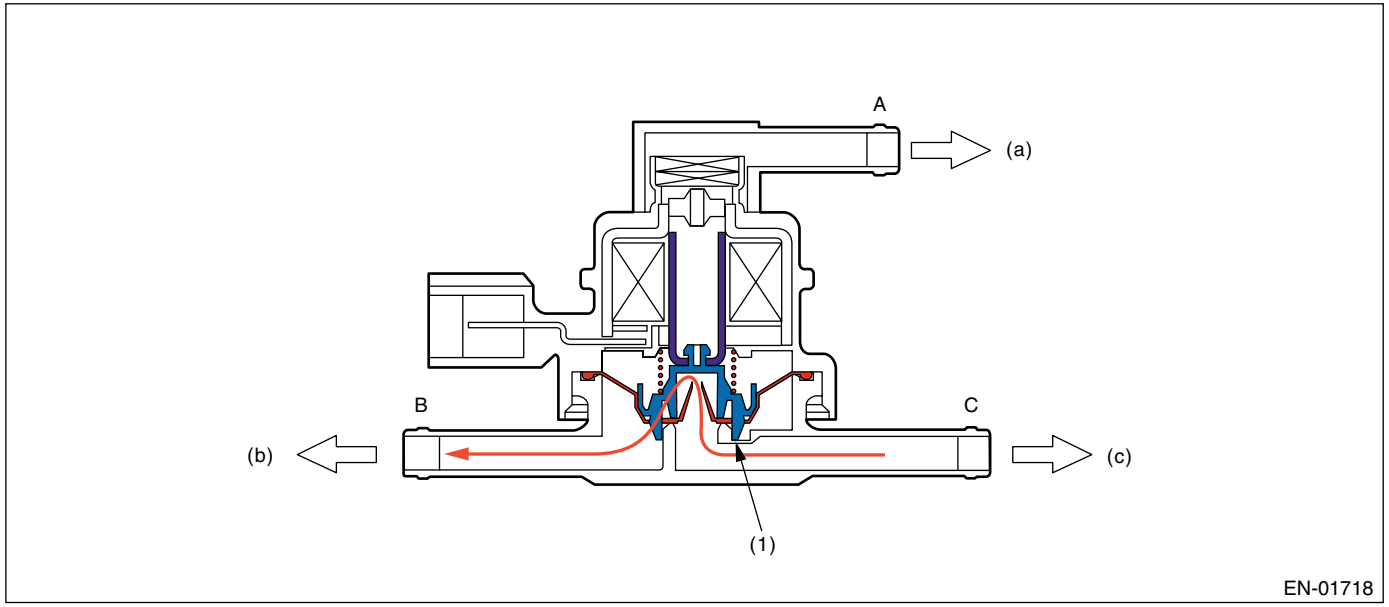

- (1) Valve
- (a) Atmospheric pressure
- (b) Fuel tank
- (c) Canister

# Diagnostic Trouble Code (DTC) Detecting Criteria

## GENERAL DESCRIPTION

### When solenoid is ON

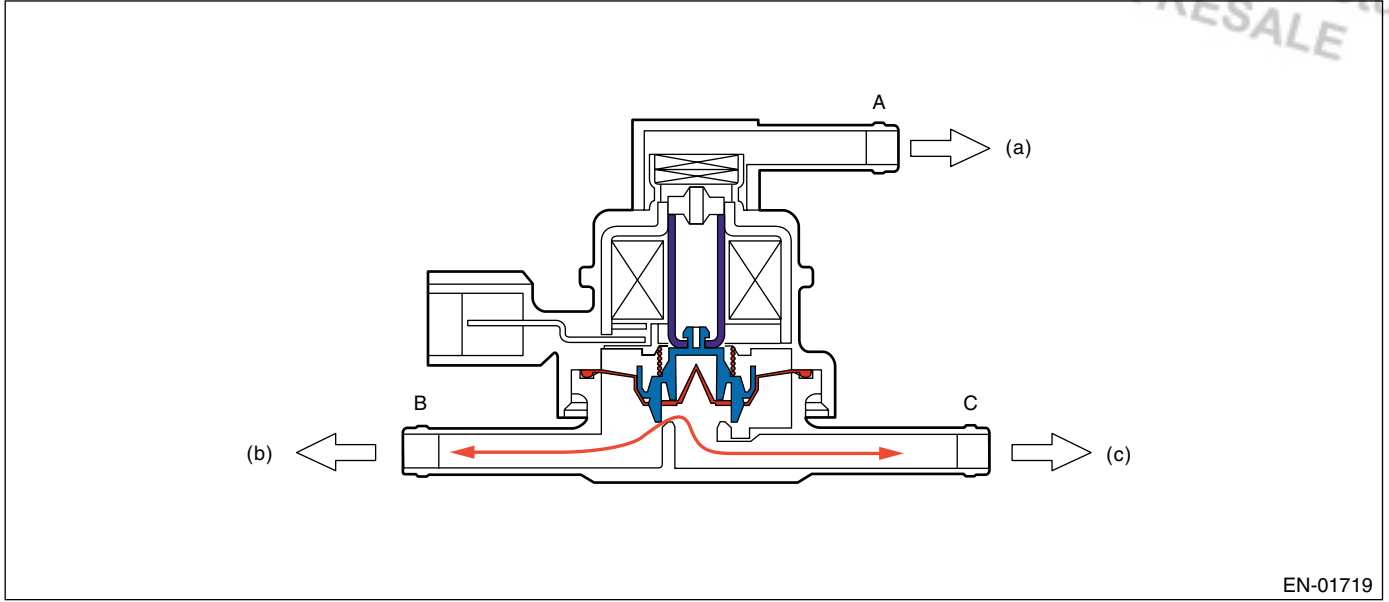

- (a) Atmospheric pressure
- (b) Fuel tank
- (c) Canister

# Diagnostic Trouble Code (DTC) Detecting Criteria

GENERAL DESCRIPTION

## • CCV

CCV controls the ambient air to be introduced to the canister.

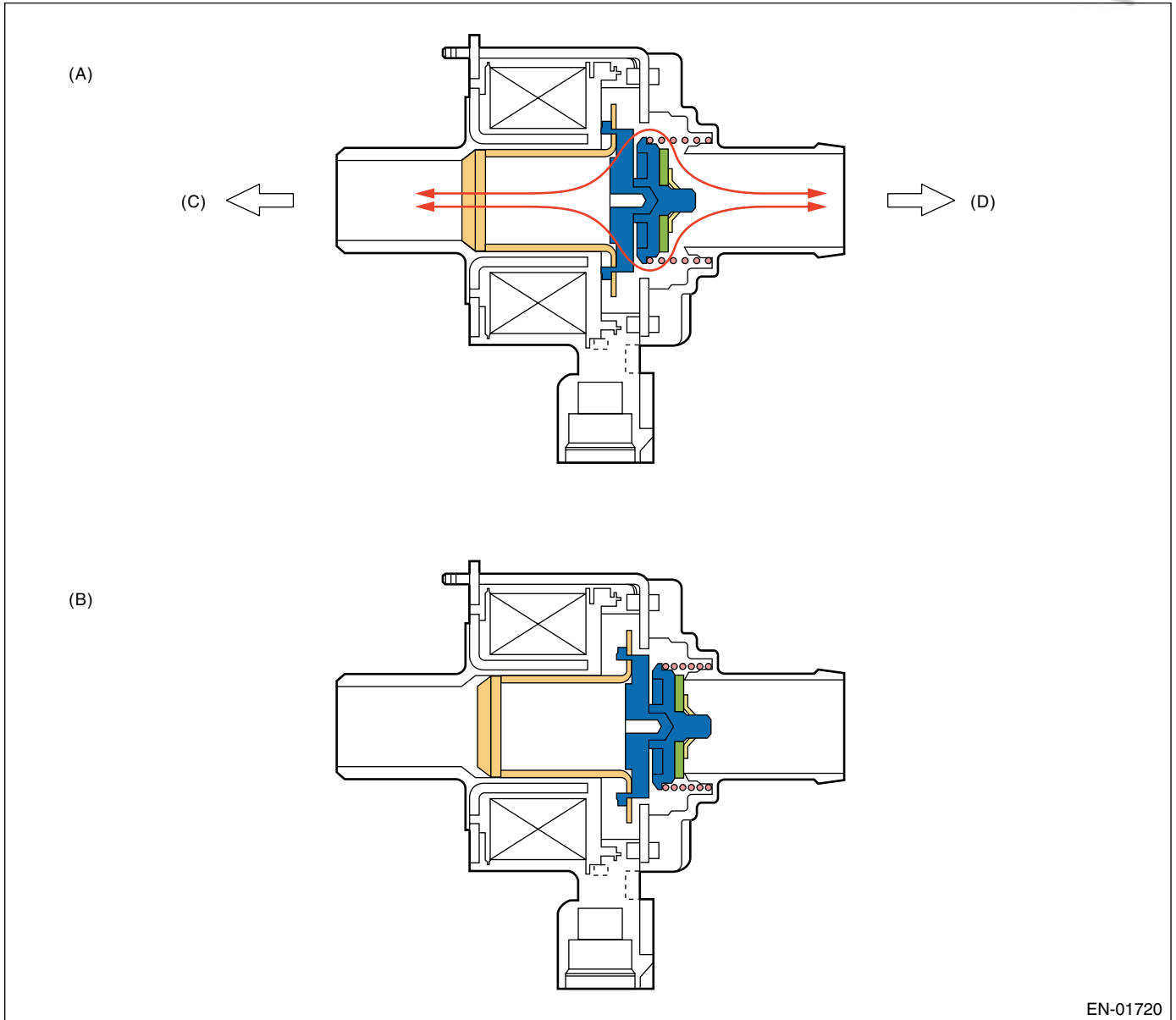

EN-01720

- (A) Open (Solenoid OFF)
- (B) Close (Solenoid ON)
- (C) Filter
- (D) Canister



# Diagnostic Trouble Code (DTC) Detecting Criteria

## GENERAL DESCRIPTION

### • Tank Pressure Switching Solenoid

One of the atmospheric pressure switching solenoid valves is connected to fuel tank pressure sensor and the other is released to atmosphere. The passage to fuel tank pressure sensor is usually released to atmosphere because the solenoid is set to OFF, but the solenoid which is set to ON closes the passage open to atmosphere.

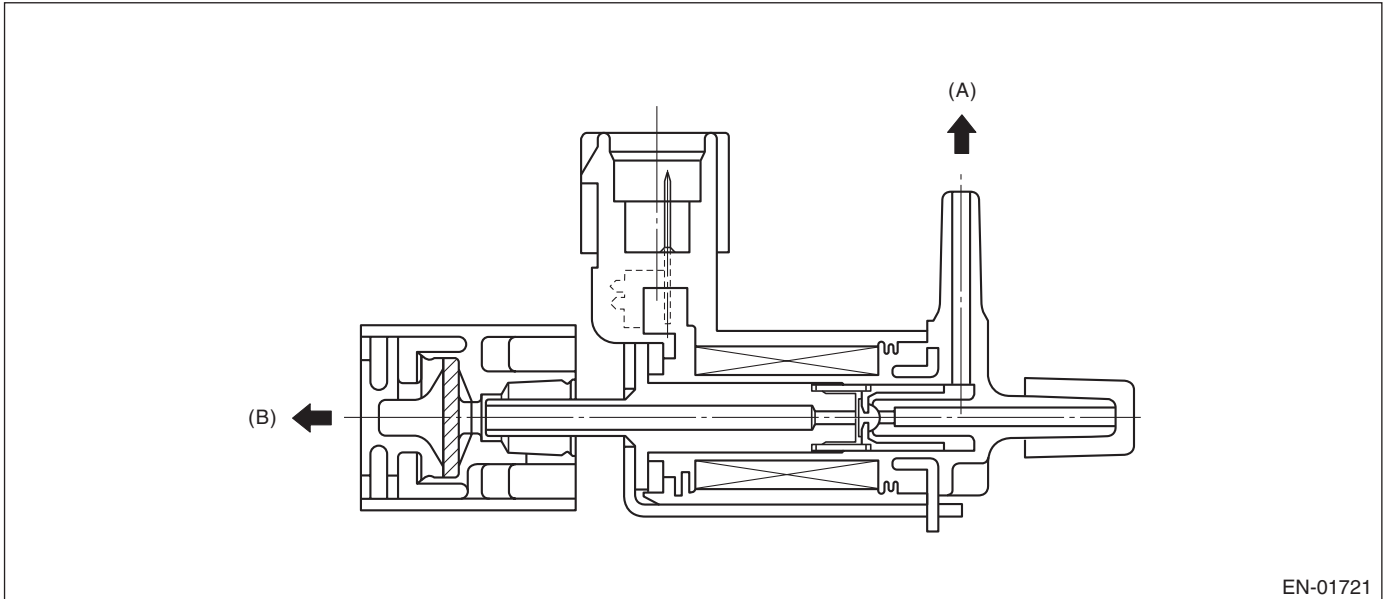

- (A) Fuel tank pressure sensor
- (B) Ambient air

# Diagnostic Trouble Code (DTC) Detecting Criteria

GENERAL DESCRIPTION

## Purpose of this solenoid

Fuel tank pressure sensor detects the difference between the atmospheric air pressure and the tank pressure, and the ECM monitors the pressure difference.

Even if the tank pressure is constant, the atmospheric air pressure varies depending on the driving height, and the pressure signal transmitted to ECM will change.

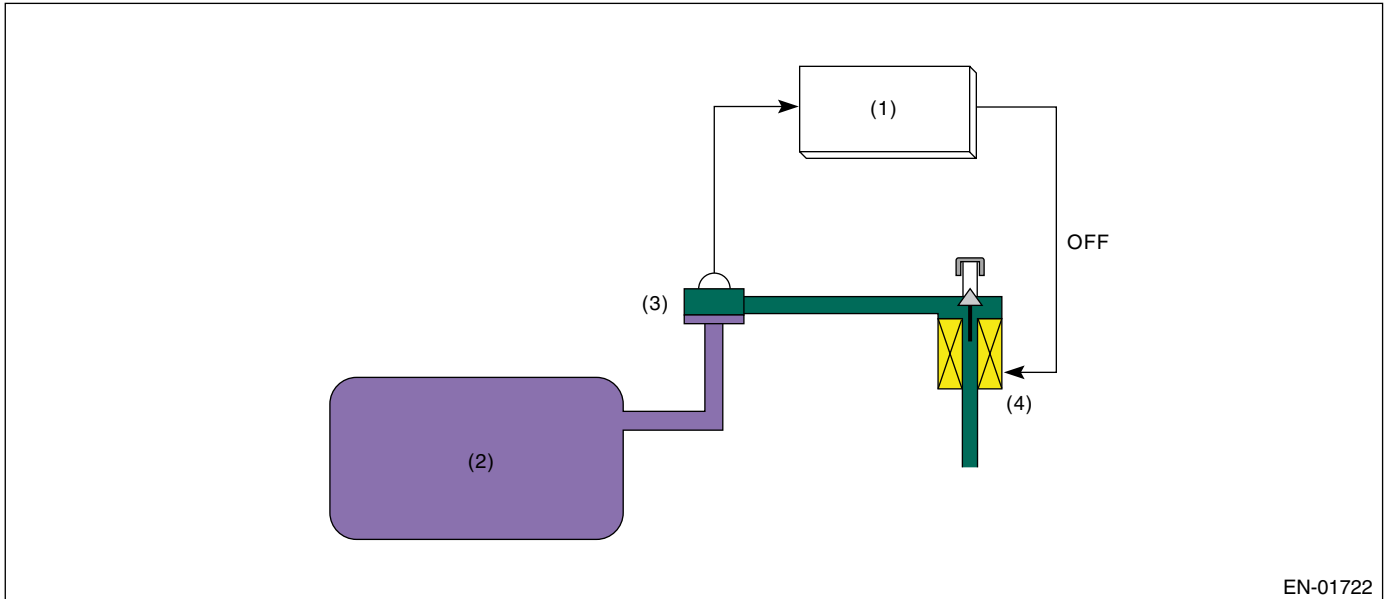

EN-01722

- (1) Engine control module (ECM)
- (2) Fuel tank
- (3) Fuel tank pressure sensor
- (4) Atmospheric pressure switching solenoid

## Diagnostic Trouble Code (DTC) Detecting Criteria

### GENERAL DESCRIPTION

Especially, in the small leakage [0.5 mm (0.02 inch)], minute change in the tank pressure has to be detected. This diagnosis period is long (approx. 29 seconds). And if the driving height changes during the diagnosis, the atmospheric air pressure changes. In this case, it becomes difficult to precisely detect the tank pressure variation, causing erroneous diagnosis. Therefore, using the atmospheric pressure switching solenoid, atmospheric air is sealed between the fuel tank pressure sensor and atmospheric pressure switching solenoid, maintaining the air pressure constant and enabling the detection of minute variation of tank pressure.

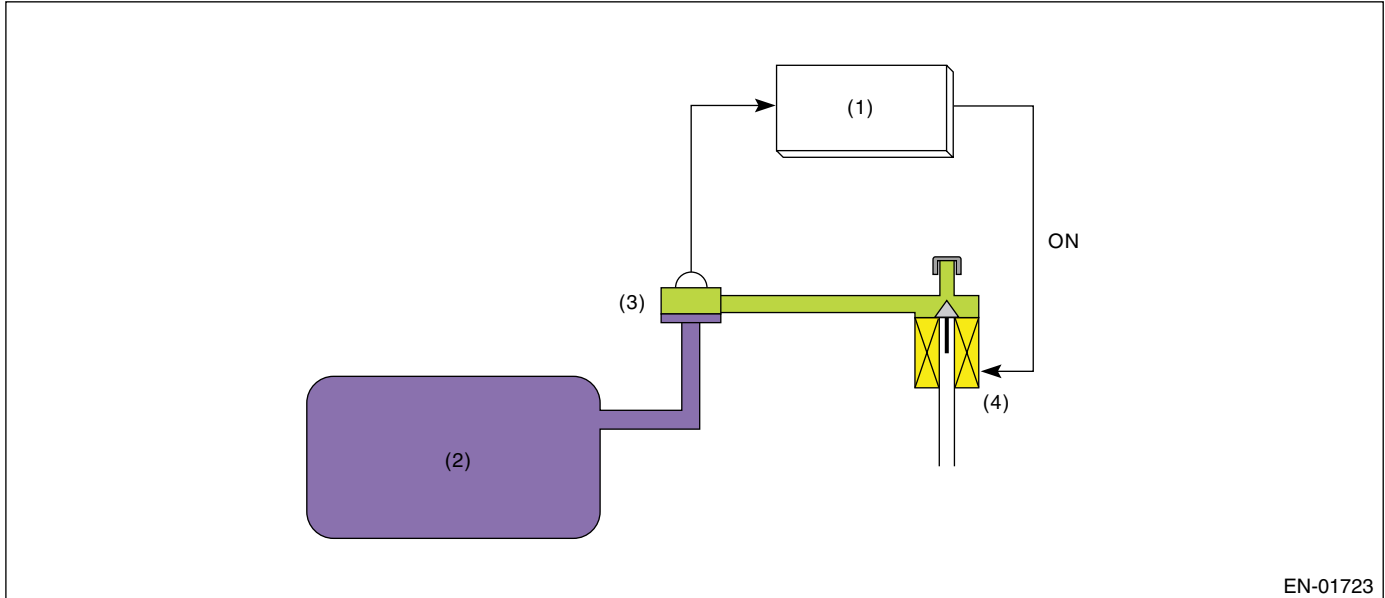

- (1) Engine control module (ECM)
- (2) Fuel tank
- (3) Fuel tank pressure sensor
- (4) Atmospheric pressure switching solenoid

#### NOTE:

ECM also has the atmospheric air pressure sensor, and always monitors atmospheric air. However, as the monitoring range is large, that is, 53.3 to 107 kPa (400 to 800 mmHg, 15.7 to 31.6 inHg), it is not suitable for detection of minute pressure variation.

In the case of small leakage diagnosis, the tank pressure variation is very small, that is, 0.13 to 0.26 kPa (1 to 2 mmHg, 0.04 to 0.08 inHg), and the fuel tank pressure sensor is equipped.

# Diagnostic Trouble Code (DTC) Detecting Criteria

GENERAL DESCRIPTION

## 3. ENABLE CONDITION

### 0.04-inch Diagnosis

Secondary Parameters	Enable Conditions
Evaporation diagnosis	Incomplete
Battery voltage	$\geq 10.9$ V
Barometric pressure	$\geq 75.1$ kPa (563 mmHg, 22.2 inHg)
Total time of canister purge operation	120 seconds or more
After engine starting	856 seconds or more
Learning value of evaporation gas density	$\leq 0.08$
Engine speed	1,050 $\longleftrightarrow$ 6,500 rpm
Fuel tank pressure	$\geq -4.0$ kPa (-30 mmHg, -1.2 inHg)
Atmospheric pressure – Intake manifold vacuum (relative pressure)	$\geq 13.3$ kPa (100 mmHg, 3.92 inHg)
Vehicle speed	$\geq 32$ km/h (20 MPH)
Fuel level	9 $\longleftrightarrow$ 51 $\ell$ (2.38 $\longleftrightarrow$ 13.5 US gal, 1.98 $\longleftrightarrow$ 11.2 Imp gal)
A/F feedback control	In operation
Fuel temperature	-10 $\longleftrightarrow$ 45°C (14 $\longleftrightarrow$ 113°F)
Intake air temperature	$\geq -10$ °C (14°F)
Pressure change per second	$< 0.13$ kPa (0.95 mmHg, 0.04 inHg)
Min. pressure change per second – Max. pressure change per second	$< 0.23$ kPa (1.75 mmHg, 0.07 inHg)
Fuel level change	$< 3$ $\ell$ (0.79 US gal, 0.66 Imp gal)/131 milliseconds
Air fuel ratio	$> 0.76$

# Diagnostic Trouble Code (DTC) Detecting Criteria

## GENERAL DESCRIPTION

### 0.02-inch Diagnosis

Secondary Parameters	Enable Conditions
(At starting a diagnosis)	
EVAP. diagnosis	Incomplete
Battery voltage	≥ 10.9 V
Atmospheric pressure	≥ 75.1 kPa (563 mmHg, 22.2 inHg)
Since last incomplete diagnosis event of 0.02-inch leakage	≥ 120 seconds
Total time of canister purge operation	120 second or more
After engine starting	335 second or more
Fuel temperature, or the time after engine start with coolant temperature of 40°C (104°F) or below	-10 ↔ 35°C (14 ↔ 95°F) < 2,400 seconds
Fuel level	9 ↔ 51 ℓ (2.38 ↔ 13.5 US gal, 1.98 ↔ 11.2 Imp gal)
(Ambient (estimate) – fuel) temperature	< 1°C (1.8°F)
Fuel tank pressure below -3.01 kPa (-22.8 mmHg, -0.88 inHg) (during same driving cycle, Intake manifold vacuum (relative pressure))	Up to 2 times
Atmospheric – Intake manifold vacuum (relative pressure)	≥ 13.3 kPa (100 mmHg, 3.92 inHg)
Fuel tank pressure	-0.67 to 0.93 kPa (-5 to 7 mmHg, -0.20 to 0.27 inHg)
Vehicle speed	≥ 68 km/h (42 MPH)
A/F feedback control	In operation
Ambient temperature (estimate)	≥ -10°C (14°F)
(During diagnosis)	
P1	-0.07 ↔ 0.13 kPa (-0.5 ↔ 1 mmHg, -0.02 ↔ 0.04 inHg)
Pressure change per second	< 0.13 kPa (0.95 mmHg, 0.04 inHg)
Fuel level change	1.5 ↔ 3 ℓ (0.4 ↔ 0.8 US gal, 0.3 ↔ 0.7 Imp gal)
Tank pressure	< 0.93 kPa (7 mmHg, 0.27 inHg)
Min. tank pressure change per second – Max. tank pressure change per second	< 0.23 kPa (1.75 mmHg, 0.07 inHg)
Change of atmospheric pressure during P1 calculation	-0.07 ↔ 0.15 kPa (-0.5 ↔ 1.125 mmHg, -0.02 ↔ 0.04 inHg)
Change of atmospheric pressure during P2 calculation	-0.15 ↔ 0.15 kPa (-1.125 ↔ 1.125 mmHg, -0.04 ↔ 0.04 inHg)

# Diagnostic Trouble Code (DTC) Detecting Criteria

GENERAL DESCRIPTION

## 4. GENERAL DRIVING CYCLE

### 0.04-inch Diagnosis

Perform the diagnosis only once in 856 seconds or more after starting the engine constantly at 32 km/h (20 MPH) or more.

Pay attention to the fuel temperature and fuel level.

### 0.02-inch Diagnosis

Perform the diagnosis in 335 seconds after starting the engine constantly at 68 km/h (42 MPH) or more, and perform OK/NG judgment.

If OK/NG judgment is not possible, repeat the diagnosis.

Pay attention to the fuel temperature and fuel level.

## 5. DIAGNOSTIC METHOD

### • Diagnosing Function of Drain Valve and Purge Control Solenoid Valve

#### DTC

P0457 Evaporative Emission Control System Leak Detected (Fuel Cap Loose/Off)

P1443 Vent Control Solenoid Valve Function Problem

#### Purpose of Mode Z

When performing the leakage diagnosis of EVAP system, CCV and CPC have to operate normally. Therefore, mode Z is used to diagnose the CCV close fixation and CPC open fixation.

If the CCV closed fixation trouble or CPC open fixation trouble is detected, the evaporation system leakage diagnosis is cancelled.

If the CCV closed fixation trouble occurred, negative pressure is generated from the engine to PCV when PCV is closed and CPC is opened. In this status, the pressure control solenoid valve solenoid, which is set to ON, does not open the valve for its structure when the negative pressure is larger than electromagnetic force.

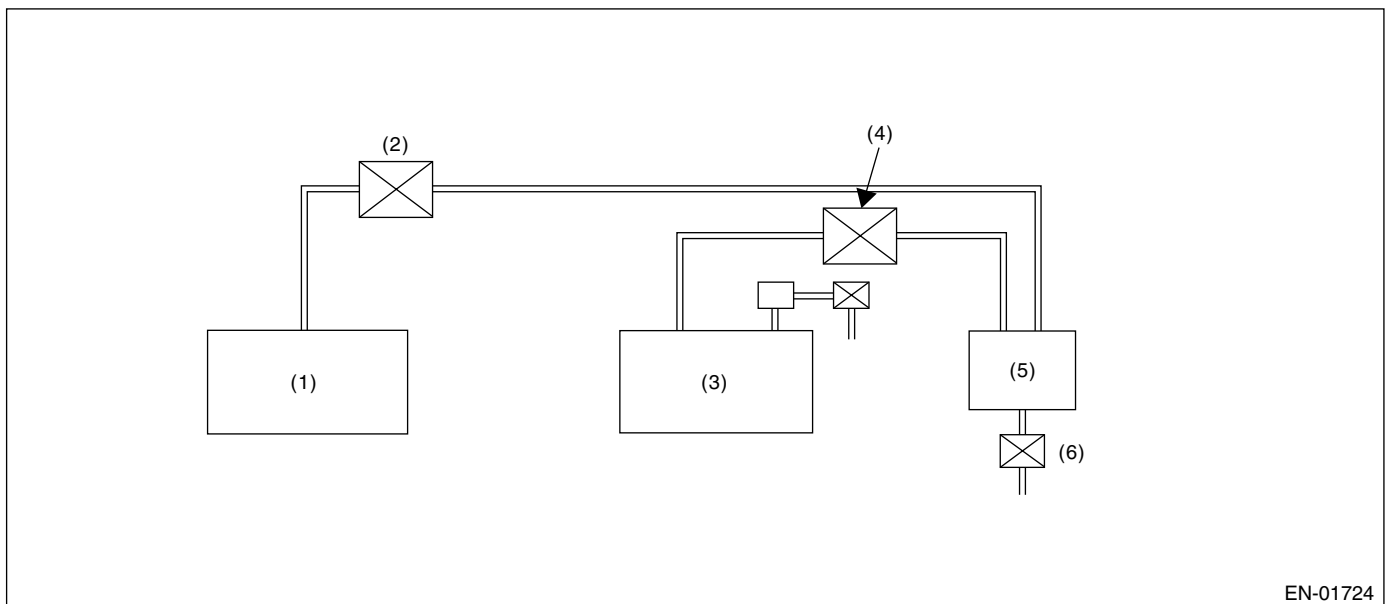

- (1) Engine
- (2) Purge control solenoid valve (Open)
- (3) Fuel tank

- (4) Pressure control solenoid valve (Close)
- (5) Canister
- (6) Drain valve (Stuck close)

# Diagnostic Trouble Code (DTC) Detecting Criteria

## GENERAL DESCRIPTION

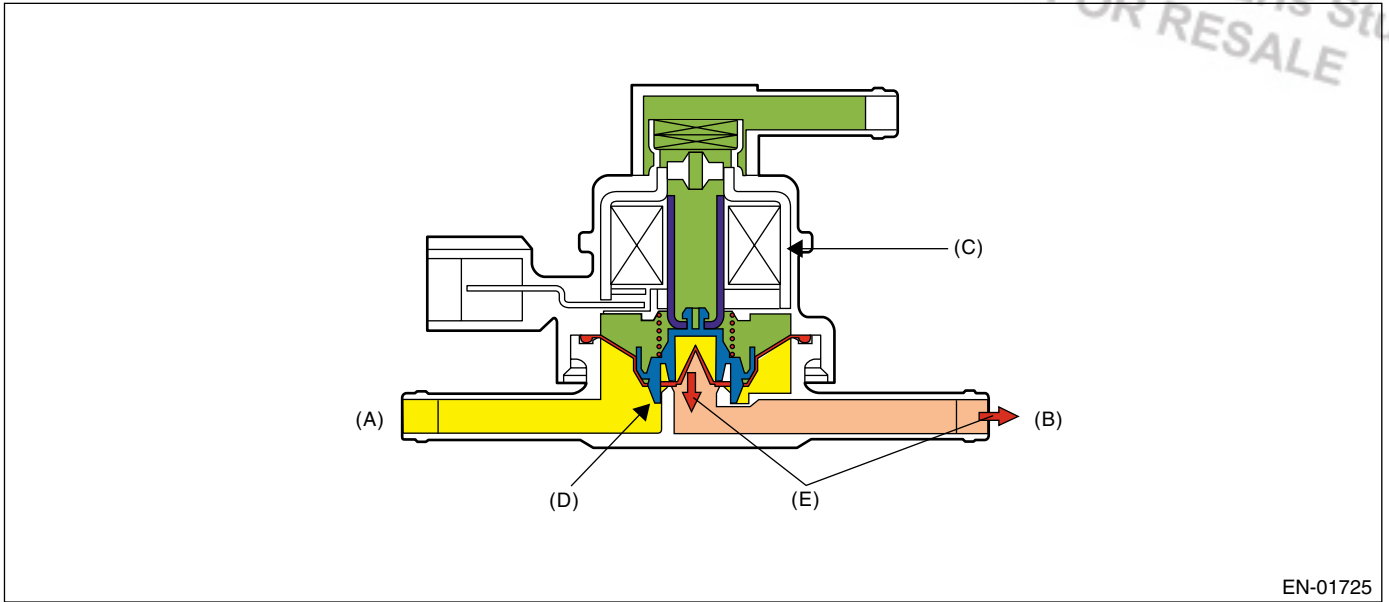

EN-01725

- (A) To fuel tank
- (B) To canister (Negative pressure)
- (C) Solenoid ON
- (D) Valve cannot be open.
- (E) Negative pressure

### Diagnostic method

CCV closed fixation diagnosis and CPC open fixation diagnosis are performed in mode Z as shown in the figure below.

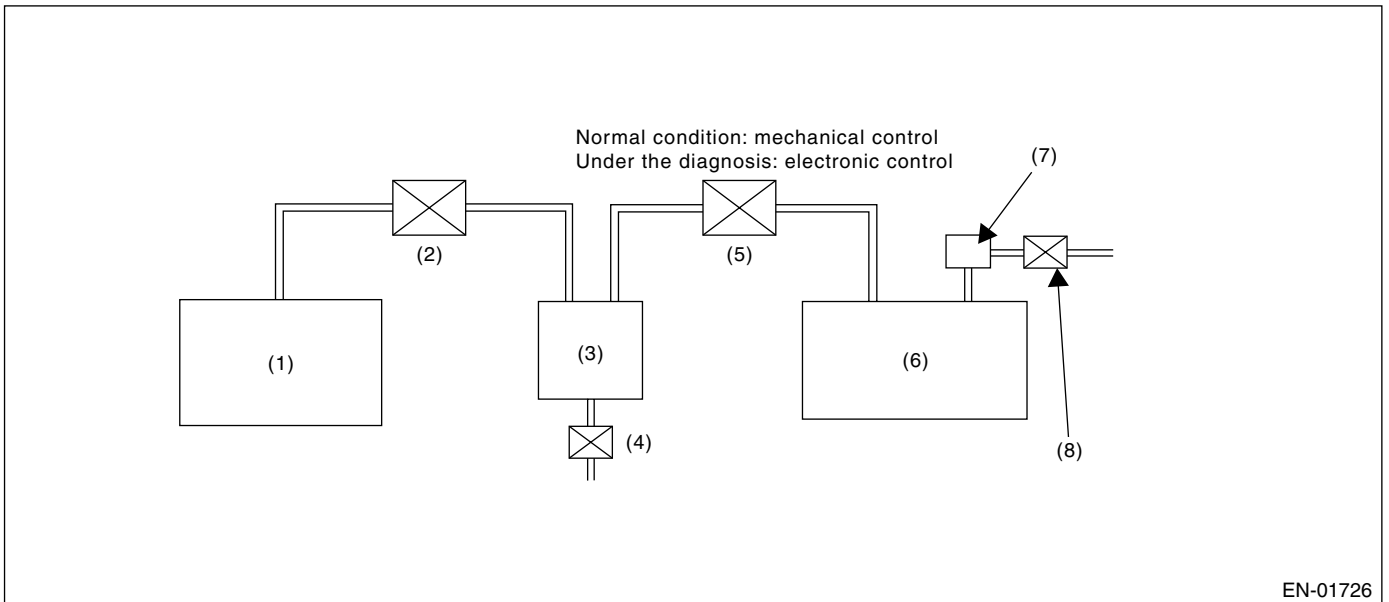

EN-01726

- (1) Engine
- (2) Purge control solenoid valve
- (3) Canister
- (4) Drain valve
- (5) Pressure control solenoid valve
- (6) Fuel tank
- (7) Fuel tank pressure sensor
- (8) Atmospheric pressure switching solenoid

# Diagnostic Trouble Code (DTC) Detecting Criteria

GENERAL DESCRIPTION

• Normal

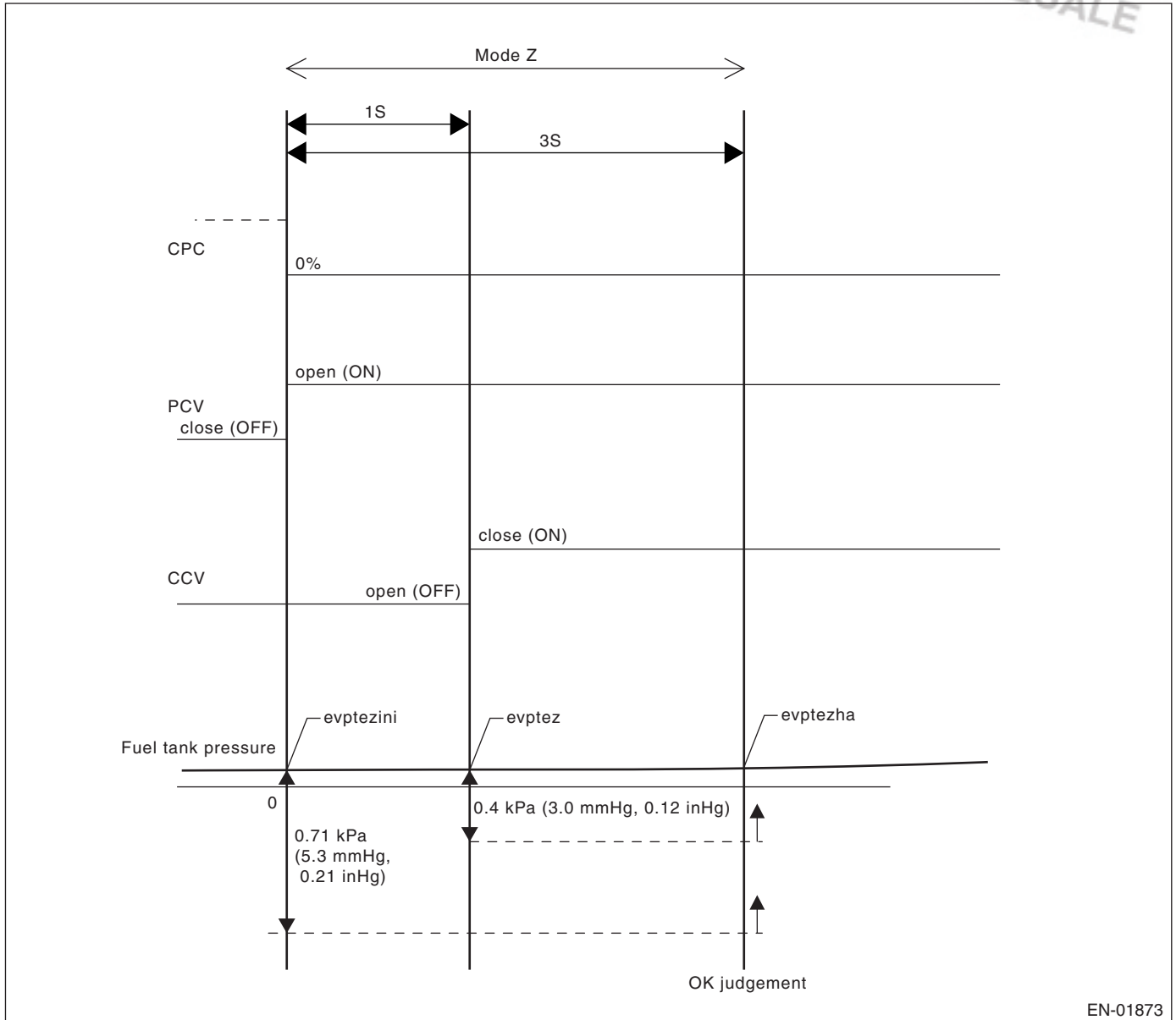

EN-01873

Judge normal when the following conditions are completed at once.

- $evptez - evptezha \leq 0.4 \text{ kPa (3.0 mmHg, 0.12 inHg)}$
- $evptezini - evptezha \leq 0.71 \text{ kPa (5.3 mmHg, 0.21 inHg)}$



# Diagnostic Trouble Code (DTC) Detecting Criteria

## GENERAL DESCRIPTION

### • Purge control solenoid valve open fixation

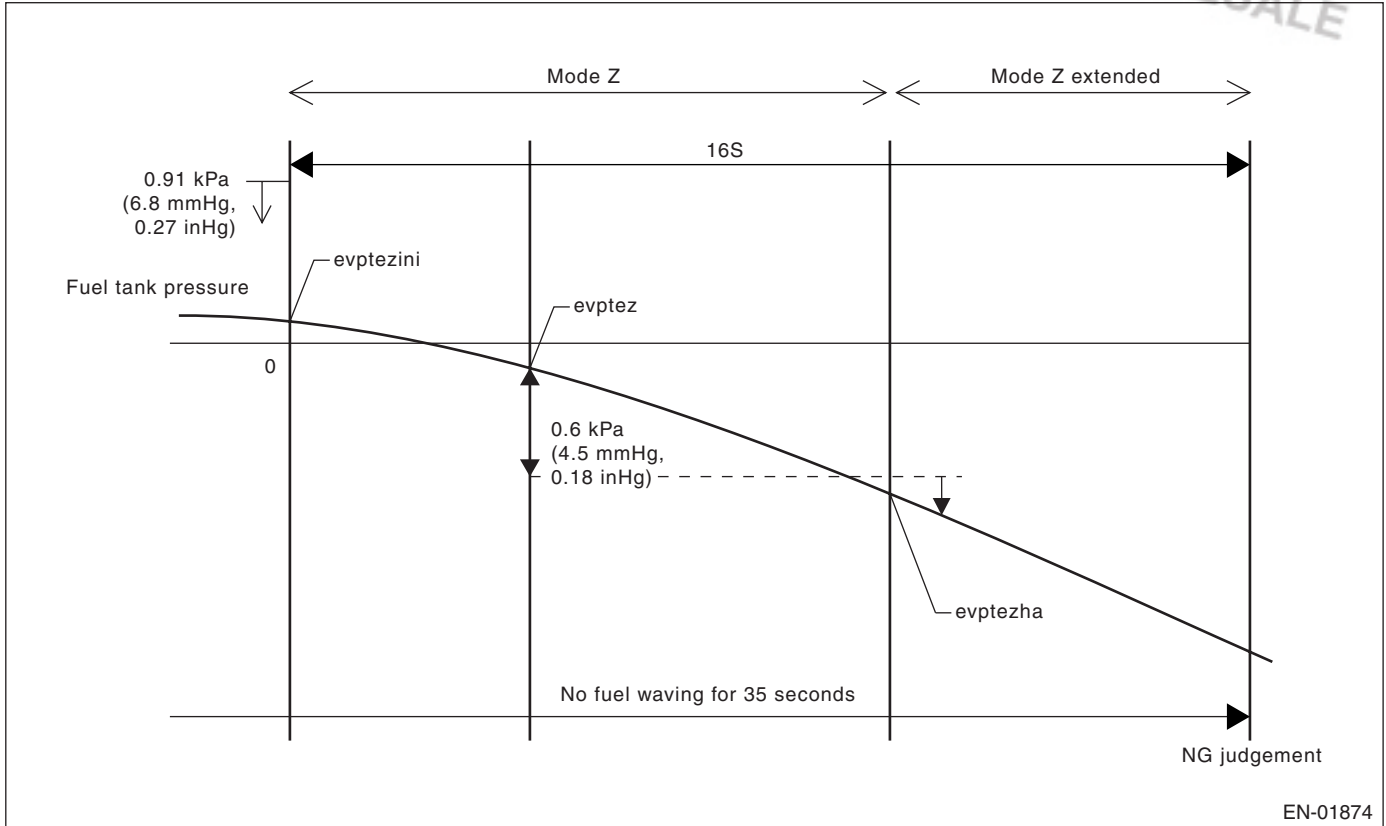

Judge NG when the following conditions are completed at once.

- $evptez - evptezha > 0.6 \text{ kPa (4.5 mmHg, 0.18 inHg)}$
- $evptezini \leq 0.91 \text{ kPa (6.8 mmHg, 0.27 inHg)}$
- Period without 3  $\ell$  (0.79 US gal, 0.67 Imp gal) or more fuel waving is 35 seconds or more.

# Diagnostic Trouble Code (DTC) Detecting Criteria

GENERAL DESCRIPTION

## • Drain valve close fixation

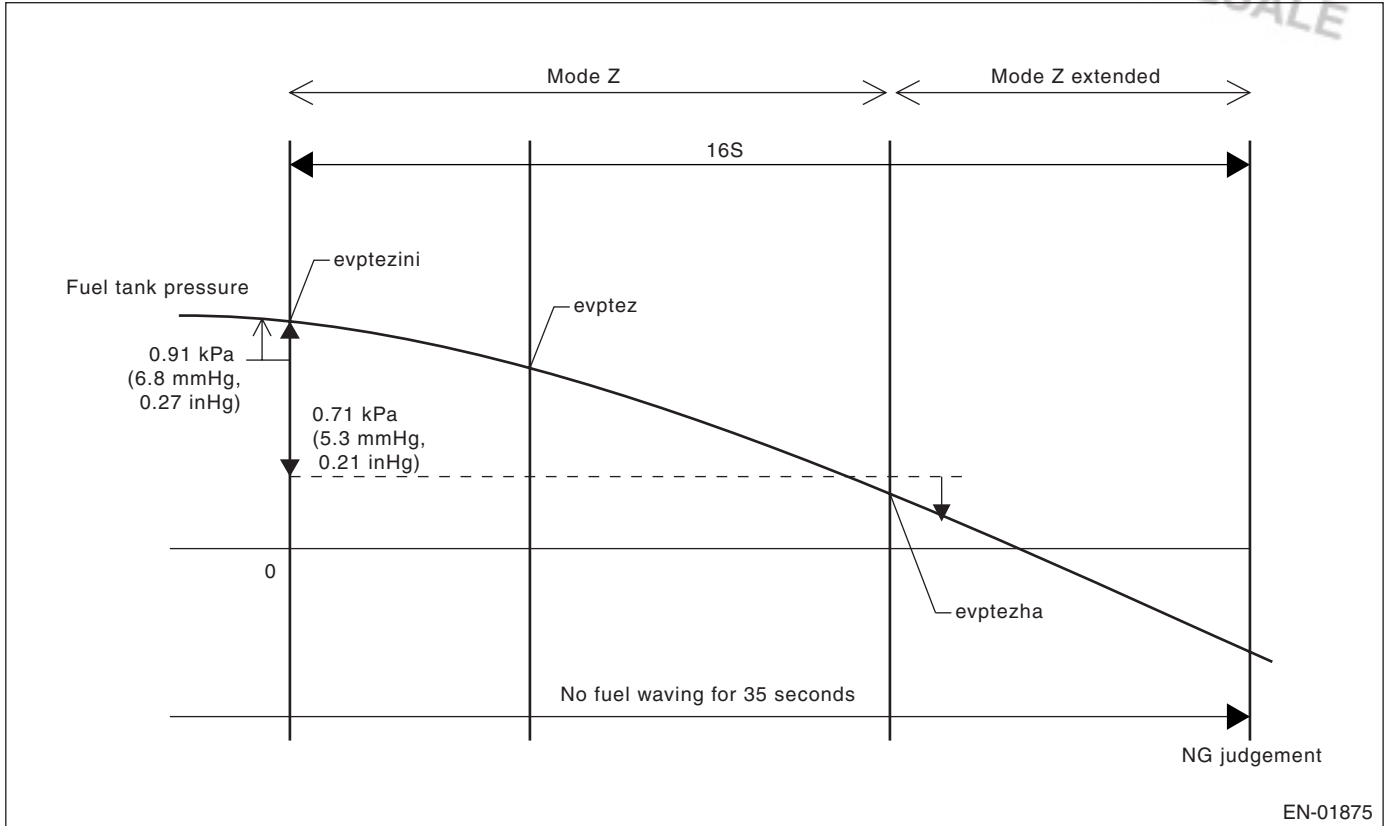

Judge NG when the following conditions are completed at once.

- $evptez - evptezha > 0.71 \text{ kPa (5.3 mmHg, 0.21 inHg)}$
- $evptezini > 0.91 \text{ kPa (6.8 mmHg, 0.27 inHg)}$
- Period without 3 L or more fuel waving is 35 seconds or more.

### • Diagnosing Function of Drain Valve [P1443]

Perform the drain valve function diagnosis by monitoring the tank pressure variation in Mode Z.

#### Normality Judgment

Judge OK when following malfunction criterias are completed within 3 seconds after starting Mode Z, and move to Mode A in case of OK.

#### Judgment Value

Malfunction Criteria	Threshold Value	DTC
(Tank pressure in 1 second after Mode Z started) – (Tank pressure when terminating Mode Z)	$\leq 0.40 \text{ kPa (3 mmHg, 0.12 inHg)}$	P1443
(Tank pressure when starting Mode Z) – (Tank pressure when terminating Mode Z)	$\leq 0.71 \text{ kPa (5.3 mmHg, 0.21 inHg)}$	P0457

#### Abnormality Judgment

If OK judgment is not possible, prolong Mode Z (16 seconds), and judge NG when all of malfunction criterias are completed with considering the following conditions in 16 seconds.

#### Judgment Value

Malfunction Criteria	Threshold Value	DTC
Tank pressure when starting Mode Z	$> 0.91 \text{ kPa (6.8 mmHg, 0.27 inHg)}$	P1443
(Tank pressure when starting Mode Z) – (Tank pressure when terminating Mode Z)	$> 0.71 \text{ kPa (5.3 mmHg, 0.21 inHg)}$	
Period without fuel waving	$\geq 35 \text{ seconds}$	

# Diagnostic Trouble Code (DTC) Detecting Criteria

## GENERAL DESCRIPTION

**Time Needed for Diagnosis:** 16 seconds

**Malfunction Indicator Light Illumination:** Illuminates when malfunction occurs in two continuous drive cycles.

When the drain valve closed fixation NG judgment is performed, terminate the evaporation diagnosis.

Cancel the Evap. diagnosis when the OK/NG judgment for drain valve close fixation and purge control solenoid valve open fixation cannot be made in Mode Z.

### • Diagnosing Function of Purge Control Solenoid Valve [P0457]

Perform the function diagnosis of the purge control solenoid valve by monitoring the tank pressure in Mode Z.

#### Normality Judgment

Perform OK judgment in 3 seconds after starting Mode Z and move to Mode A if OK.

Diagnostic method and judgment value are the same as in case of purge control solenoid valve normal.

#### Abnormality Judgment

If OK judgment is not possible, prolong Mode Z (16 seconds), and judge NG when all of malfunction criterias are completed after 16 seconds considering the following conditions.

#### Judgment Value

Malfunction Criteria	Threshold Value	DTC
(Tank pressure in 1 second after Mode Z started) – (Tank pressure when terminating Mode Z)	> 0.60 kPa (4.5 mmHg, 0.18 inHg)	P0457
Tank pressure when starting Mode Z	≤ 0.91 kPa (6.8 mmHg, 0.27 inHg)	
Period without fuel waving	≥ 35 seconds	

**Time Needed for Diagnosis:** 16 seconds

**Malfunction Indicator Light Illumination:** Detect when malfunction occurs in two continuous drive cycles.

If the purge control solenoid valve open fixation NG judgment is performed, terminate the EVAP. diagnosis.

If OK/NG judgment of the drain valve closed fixation and purge control solenoid valve open fixation is not possible in Mode Z, cancel the EVAP. diagnosis.

### • Leakage Diagnosis

#### DTC

P0442 Evaporative Emission Control System Leak Detected (Small Leak)

P0456 Evaporative Emission Control System Leak Detected (Very Small Leak)

P0457 Evaporative Emission Control System Leak Detected (Fuel Cap Loose/Off)

#### Diagnostic Method

The diagnostic method consists of creating a sealed vacuum in the fuel tank and then determining the presence of leakage from the speed at which the tank internal pressure returns to atmospheric pressure.

#### Mode A; (Estimation of evaporation abundance)

Calculate the tank pressure variation amount (P1). Move to Mode B after calculating P1.

#### Mode B; (Seal negative pressure)

Introduce the negative pressure of the intake manifold into the tank.

Approx. 0 → -1.4 kPa (0 → -10.5 mmHg, 0 → -0.41 inHg) (0.04-inch diagnosis)

Approx. 0 → -3.05 kPa (0 → -22.875 mmHg, 0 → -0.9 inHg) (0.02-inch diagnosis)

Move to Mode C when reaching the pressure above (target pressure).

Then, if the tank pressure does not become negative, judge that there is large leakage in the system. In 0.04-inch diagnosis, judge that there is large leakage (10 seconds or 25 seconds) and terminate the EVAP. diagnosis. In 0.02-inch diagnosis, cancel the diagnosis (20 seconds).

#### Abnormality Judgment

Judge NG (large leakage) when the malfunction criteria below is completed.

# Diagnostic Trouble Code (DTC) Detecting Criteria

GENERAL DESCRIPTION

## Judgment Value

Malfunction Criteria	Threshold Value	DTC
(0.04-inch diagnosis) Period until reaching target negative pressure OR, Mode B period (Tank Pressure Min. Value in Mode B) – (Tank Pressure when starting Mode B)	≥ 25 seconds ≥ 10 seconds > –0.53 kPa (–4 mmHg, –0.16 inHg)	P0457

### Mode C; (Check increasing pressure)

Stop the introduction of negative pressure. (Wait until returning to target pressure)

When returning to target pressure, move to Mode D.

Judge premature OK and move to Mode E when not returning in the determined period of time.

	Target Pressure	Premature OK Judgment Period
0.04-inch Diagnosis	–1.30 kPa (–9.75 mmHg, –0.38 inHg)	15 seconds
0.02-inch Diagnosis	–3.00 kPa (–22.5 mmHg, –0.89 inHg)	20 seconds

### Mode D; (Measurement of negative pressure variation)

Monitor the tank pressure variation in Mode D. In this case, the tank pressure increases (close to atmospheric pressure) because the evaporator is generated. However, if there is leakage, the pressure increases additionally. P2 means the variation amount of this tank pressure. After calculating P2, perform the small leakage diagnosis, and move to Mode E if normal. Terminate the EVAP. diagnosis if abnormal.

#### When Terminating Mode D

By assigning the variation values of tank pressure, P1 and P2, in the following formula, judge the system small leakage. If the calculated judgment value is larger than the threshold value, judge that there is a failure.

0.04-inch Diagnosis

Judge NG when the malfunction criteria below is completed, and judge OK when the malfunction criteria below is not completed.

#### Judgment Value

Malfunction Criteria	Threshold Value	DTC
P2 – 1.5 × P1 P2 = Change of tank pressure in 16 seconds at mode D. P1 = Change of tank pressure in 16 seconds at mode A.	> 0.38 ↔ 0.81 kPa* (2.86 ↔ 6.08 mmHg, 0.11 ↔ 0.24 inHg) *Threshold value: Map (fuel level vs tank temperature)	P0442

\*1.5: Correction value of the evaporator generation amount under negative pressure. (The more the negative pressure increases, the more the generation amount increases.)

0.02-inch Diagnosis

#### Abnormality Judgment

Judge NG when the malfunction criteria below is completed, and judge OK when the malfunction criteria below is not completed.

#### Judgment Value

Malfunction Criteria	Threshold Value	DTC
P2 – 1.5 × P1 P2 = Change of tank pressure in 22 seconds at mode D. P1 = Change of tank pressure in 22 seconds at mode A.	≥ 0.40 ↔ 0.97 kPa* (3 ↔ 7.3 mmHg, 0.12 ↔ 0.29 inHg) *Threshold value: Map (fuel level vs tank temperature)	P0456

#### Normality Judgment

Judge OK when the malfunction criteria below is not completed.

# Diagnostic Trouble Code (DTC) Detecting Criteria

## GENERAL DESCRIPTION

### Judgment Value

Malfunction Criteria	Threshold Value	DTC
$P2 - 1.5 \times P1$ P2 = Change of tank pressure in 22 seconds at mode A. P1 = Change of tank pressure in 22 seconds at mode A.	$< 0.31 \leftrightarrow 0.60 \text{ kPa}^*$ $(2.3 \leftrightarrow 4.5 \text{ mmHg},$ $0.09 \leftrightarrow 0.18 \text{ inHg})$ *Threshold value: Map (fuel level vs tank temperature)	P0456

If OK/NG judgment is not possible, repeat the diagnosis.

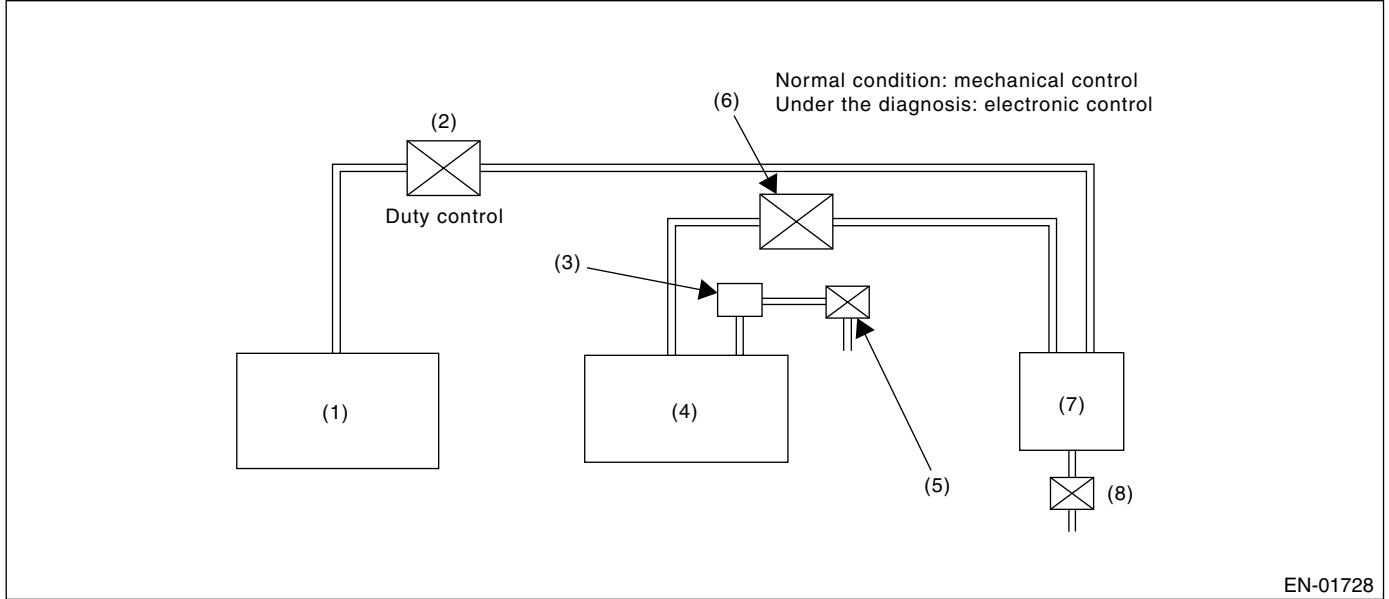

EN-01728

- (1) Engine
- (2) Purge control solenoid valve
- (3) Fuel tank pressure sensor
- (4) Fuel tank
- (5) Atmospheric pressure switching solenoid
- (6) Pressure control solenoid valve
- (7) Canister
- (8) Drain valve

# Diagnostic Trouble Code (DTC) Detecting Criteria

GENERAL DESCRIPTION

## 0.04-inch Diagnosis

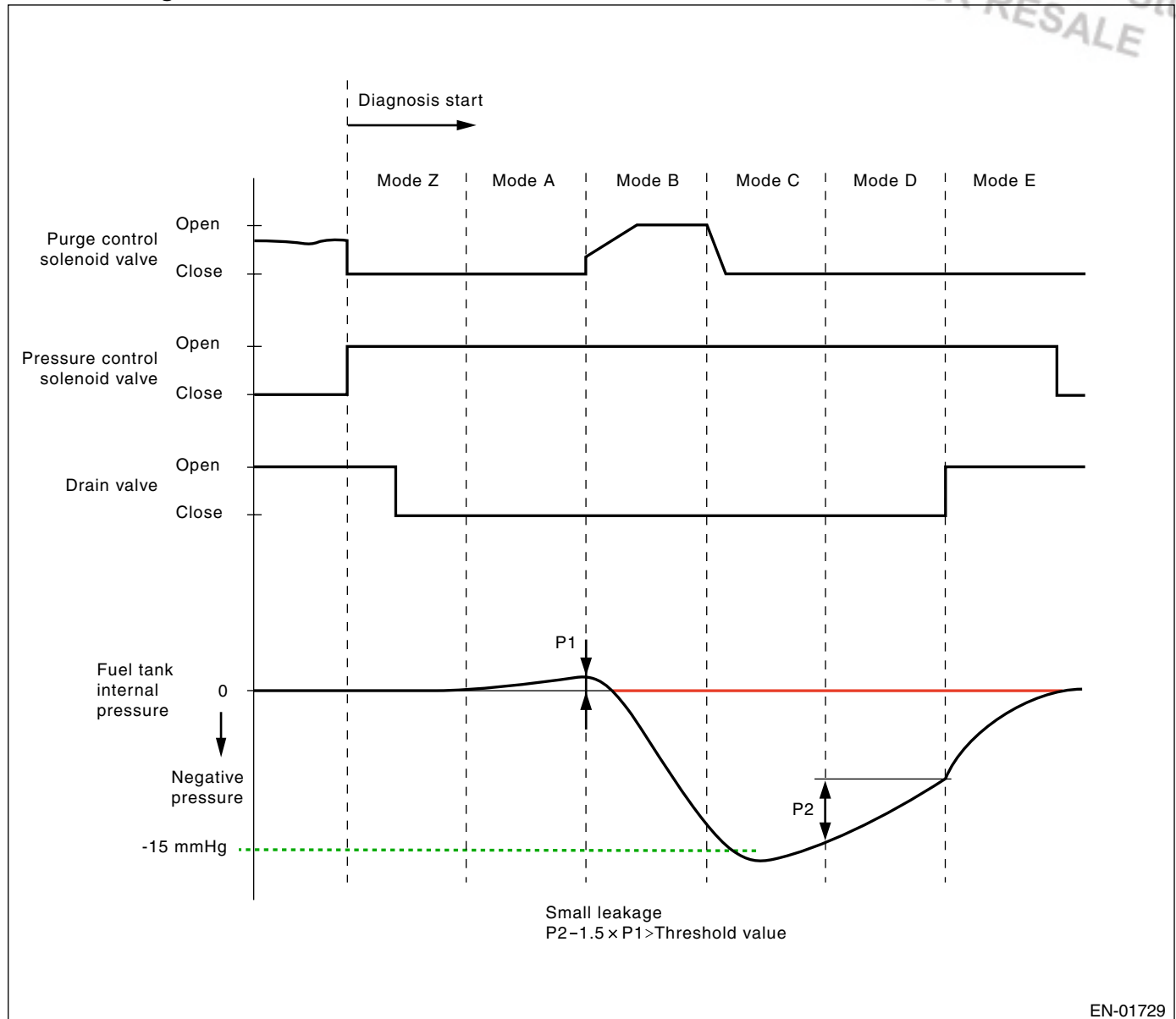

### • Drain Valve Property Diagnosis [P1443]

#### Mode E;

The tank pressure should return to the value equal to the atmospheric pressure after the evaporation diagnosis is terminated (Mode C normal judgment or Mode D termination). If the value does not return, judge that the drain valve is closed.

Judge NG when the following malfunction criteria is completed.

#### Judgment Value

Malfunction Criteria	Threshold Value	DTC
Fuel tank pressure difference between at the end of EVAP. system diagnosis and 4 seconds later.	< 0.36 kPa (2.72 mmHg, 0.11 inHg)	P1443

#### Time Needed for Diagnosis:

0.04 inches:	50 to 70 seconds
0.02 inches:	75 to 90 seconds

**Malfunction Indicator Light Illumination:** Detect when malfunction occurs in two continuous drive cycles.

## Diagnostic Trouble Code (DTC) Detecting Criteria

### GENERAL DESCRIPTION

---

#### 6. DTC CLEAR CONDITION

- When the OK idling cycle was completed 40 times in a row
- When "Clear Memory" was performed

#### 7. MALFUNCTION INDICATOR LIGHT CLEAR CONDITION

- When the OK driving cycle was completed 3 times in a row
- When "Clear Memory" was performed

#### 8. FAIL SAFE

Open the PCV when the drain valve malfunction occur.

#### 9. ECM OPERATION AT DTC SETTING

- Memorize the freeze frame data. (For test mode \$02)
- Memorize the diagnostic value and trouble standard value. (For test mode \$06)

# Diagnostic Trouble Code (DTC) Detecting Criteria

GENERAL DESCRIPTION

## AX:DTC P0447 EVAPORATIVE EMISSION CONTROL SYSTEM VENT CONTROL CIRCUIT OPEN

### 1. OUTLINE OF DIAGNOSIS

Detect the open or short circuit of drain valve.

Judge NG when the ECM output level is different from the actual terminal level.

### 2. COMPONENT DESCRIPTION

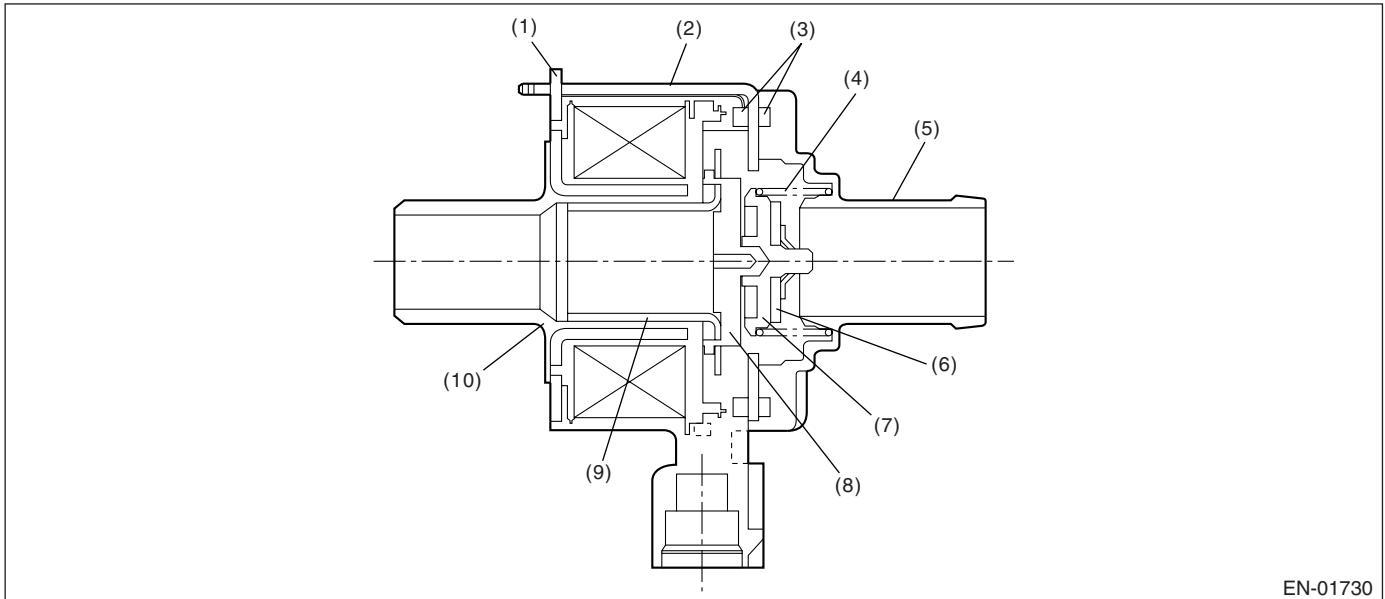

- (1) Magnetic plate
- (2) Yoke
- (3) Packing
- (4) Spring
- (5) Valve seat

- (6) Valve
- (7) Plate
- (8) Retainer
- (9) Movable core
- (10) Bobbin

### 3. ENABLE CONDITION

Secondary Parameters	Enable Conditions
None	

### 4. GENERAL DRIVING CYCLE

Always perform the diagnosis continuously.

### 5. DIAGNOSTIC METHOD

#### • Abnormality Judgment

Judge NG when the continuous time of completing the malfunction criteria below becomes more than 2.5 seconds.

#### Judgment Value

Malfunction Criteria	Threshold Value
Ignition switch	ON
Battery voltage	$\geq 10.9$ V
After engine starting	1 second or more
Terminal output voltage when ECM sends OFF signal	Low

**Time Needed for Diagnosis:** 2.5 seconds



# Diagnostic Trouble Code (DTC) Detecting Criteria

## GENERAL DESCRIPTION

**Malfunction Indicator Light Illumination:** Illuminates as soon as the malfunction occurs.

• **Normality Judgment**

Judge OK and clear the NG when the malfunction criteria below are completed.

**Judgment Value**

Malfunction Criteria	Threshold Value
Ignition switch	ON
Battery voltage	$\geq 10.9$ V
After engine starting	1 second or more
Terminal output voltage when ECM sends OFF signal	High

### 6. DTC CLEAR CONDITION

- When the OK idling cycle was completed 40 times in a row
- When "Clear Memory" was performed

### 7. MALFUNCTION INDICATOR LIGHT CLEAR CONDITION

- When the OK driving cycle was completed 3 times in a row
- When "Clear Memory" was performed

### 8. FAIL SAFE

PCV control: Open the PCV solenoid.

### 9. ECM OPERATION AT DTC SETTING

Memorize the freeze frame data. (For test mode \$02)

# Diagnostic Trouble Code (DTC) Detecting Criteria

GENERAL DESCRIPTION

## AY:DTC P0448 EVAPORATIVE EMISSION CONTROL SYSTEM VENT CONTROL CIRCUIT SHORTED

### 1. OUTLINE OF DIAGNOSIS

Detect the open or short circuit of drain valve.

Judge NG when the ECM output level is different from the actual terminal level.

### 2. COMPONENT DESCRIPTION

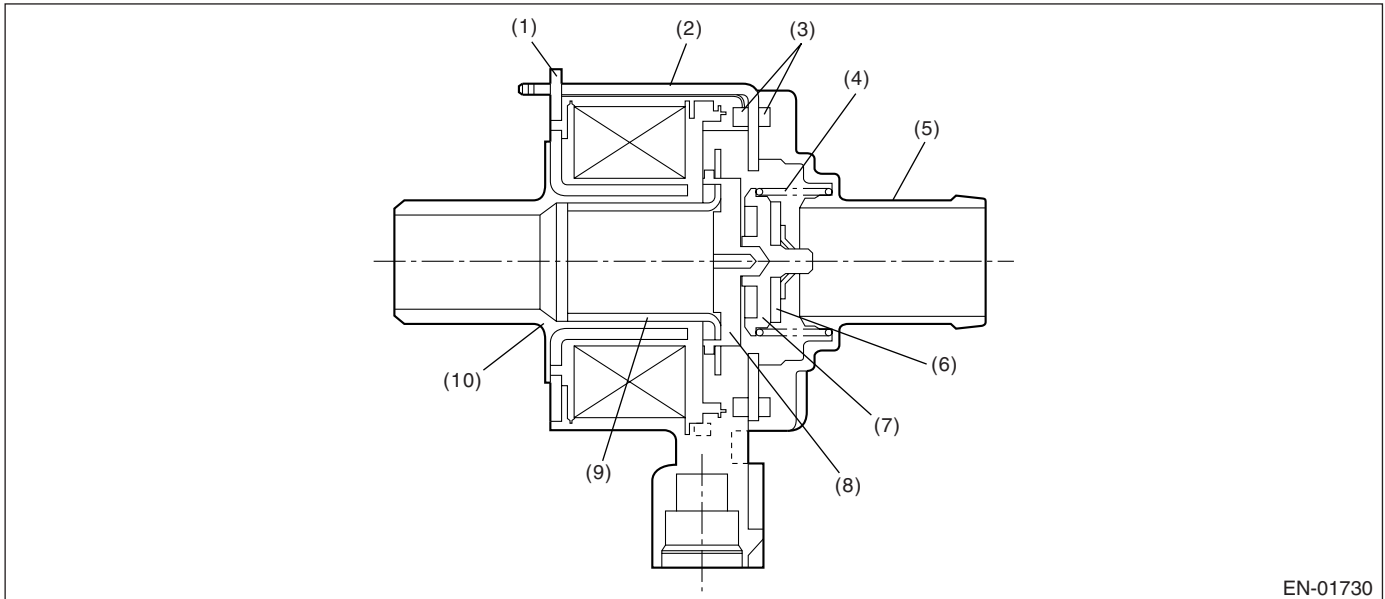

- (1) Magnetic plate
- (2) Yoke
- (3) Packing
- (4) Spring
- (5) Valve seat

- (6) Valve
- (7) Plate
- (8) Retainer
- (9) Movable core
- (10) Bobbin

### 3. ENABLE CONDITION

Secondary Parameters	Enable Conditions
None	

### 4. GENERAL DRIVING CYCLE

Always perform the diagnosis continuously.

### 5. DIAGNOSTIC METHOD

#### • Abnormality Judgment

Judge NG when the continuous time of completing the malfunction criteria below becomes more than 2.5 seconds.

#### Judgment Value

Malfunction Criteria	Threshold Value
Ignition switch	ON
Battery voltage	$\geq 10.9$ V
After engine starting	1 second or more
Terminal output voltage when ECM sends ON signal	High

**Time Needed for Diagnosis:** 2.5 seconds

# Diagnostic Trouble Code (DTC) Detecting Criteria

## GENERAL DESCRIPTION

**Malfunction Indicator Light Illumination:** Illuminates as soon as the malfunction occurs.

• **Normality Judgment**

Judge OK and clear the NG when the malfunction criteria below are completed.

**Judgment Value**

Malfunction Criteria	Threshold Value
Ignition switch	ON
Battery voltage	$\geq 10.9$ V
After engine starting	1 second or more
Terminal output voltage when ECM sends ON signal	Low

### 6. DTC CLEAR CONDITION

- When the OK idling cycle was completed 40 times in a row
- When "Clear Memory" was performed

### 7. MALFUNCTION INDICATOR LIGHT CLEAR CONDITION

- When the OK driving cycle was completed 3 times in a row
- When "Clear Memory" was performed

### 8. FAIL SAFE

PCV control: Open the PCV solenoid.

### 9. ECM OPERATION AT DTC SETTING

Memorize the freeze frame data. (For test mode \$02)

# Diagnostic Trouble Code (DTC) Detecting Criteria

GENERAL DESCRIPTION

## AZ:DTC P0451 EVAPORATIVE EMISSION CONTROL SYSTEM PRESSURE SENSOR RANGE/PERFORMANCE

### 1. OUTLINE OF DIAGNOSIS

Detect the tank pressure sensor output property abnormality.

Judge NG when there is no pressure variation, which should exist in the tank, considering the engine status.

### 2. COMPONENT DESCRIPTION

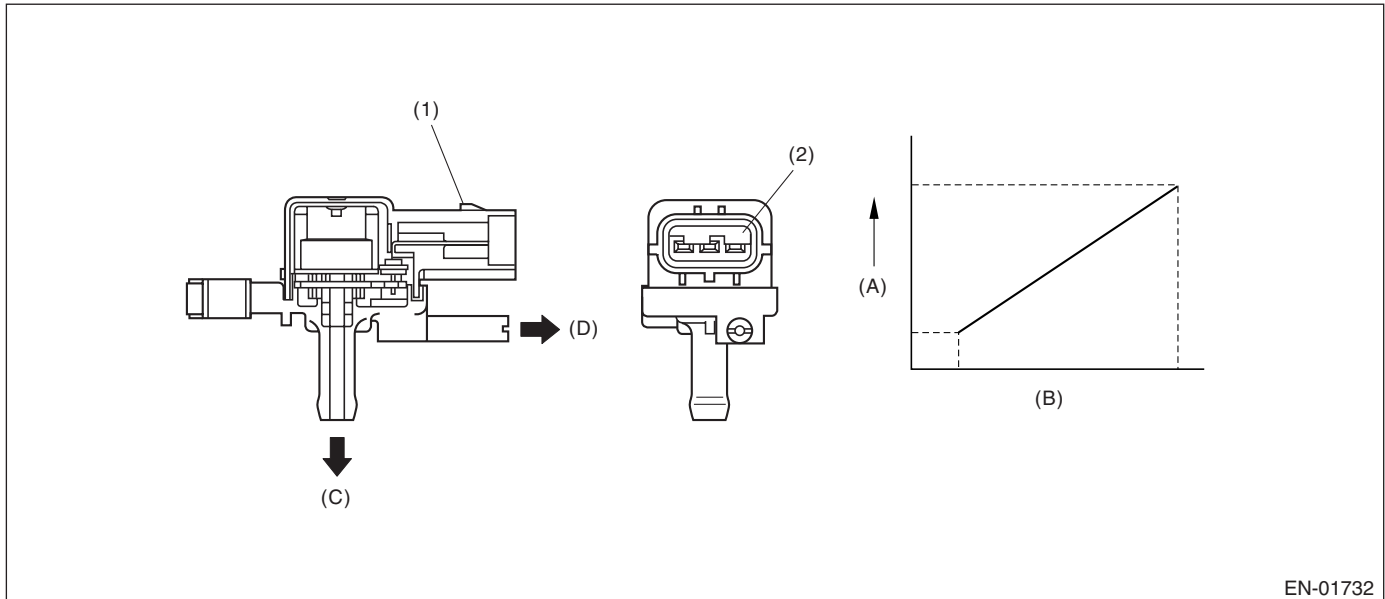

- (1) Connector
- (2) Terminal

- (A) Output voltage
- (B) Input voltage
- (C) To fuel tank
- (D) To atmospheric pressure switching solenoid

### 3. ENABLE CONDITION

Secondary Parameters	Enable Conditions
After starting the engine	60 second or more
Fuel level	$\geq 18 \text{ l}$ (4.76 US gal, 3.96 Imp gal)
Fuel temperature	$< 35^{\circ}\text{C}$ ( $95^{\circ}\text{F}$ )
Battery voltage	$\geq 10.9 \text{ V}$
Atmospheric pressure	$> 75.1 \text{ kPa}$ (563 mmHg, 22.2 inHg)
Engine speed	$< 6,500 \text{ rpm}$

### 4. GENERAL DRIVING CYCLE

- Perform the diagnosis continuously in 60 seconds or more after starting the engine.
- Be sure to check the fuel level and fuel temperature.

### 5. DIAGNOSTIC METHOD

#### • Abnormality Judgment

Judge NG when the malfunction criteria below is completed.

# Diagnostic Trouble Code (DTC) Detecting Criteria

## GENERAL DESCRIPTION

### Judgment Value

Malfunction Criteria	Threshold Value
Number of times when the difference between the Max. fuel level and the Min. fuel level every 60 seconds is 2 ℓ (0.53 US gal, 0.44 Imp gal) or more (with enable condition completed)	≥ 16 times
Max. – Min. tank pressure (with enable condition completed)	< 0.05 kPa (0.375 mmHg, 0.02 inHg)
Max. – Min. fuel temperature (with enable condition completed)	≥ 7°C (44.6 °F)

If the fuel level (Max. – Min.) in every 60 seconds is less than 2 ℓ, extend 60 seconds more and make judgment with the Max. and Min. fuel level in 120 seconds.

If the difference did not appear though the time extended, extend the time (180, 240, 300 seconds) and continue the judgment.

Diagnosis counter will count up when the difference of fuel level (Max. – Min.) is more than 2 ℓ.

**Time Needed for Diagnosis:** 1 second × 16 times or more

**Malfunction Indicator Light Illumination:** Illuminates when malfunction occurs in two continuous drive cycles.

### • Normality Judgment

Judge OK when the malfunction criteria below is completed.

### Judgment Value

Malfunction Criteria	Threshold Value
Max. – Min. tank pressure	≥ 0.05 kPa (0.375 mmHg, 0.02 inHg)

## 6. DTC CLEAR CONDITION

- When the OK idling cycle was completed 40 times in a row
- When “Clear Memory” was performed

## 7. MALFUNCTION INDICATOR LIGHT CLEAR CONDITION

- When the OK driving cycle was completed 3 times in a row
- When “Clear Memory” was performed

## 8. FAIL SAFE

Purge control solenoid valve control: Purge fixation mode is prohibited.

## 9. ECM OPERATION AT DTC SETTING

Memorize the freeze frame data. (For test mode \$02)

# Diagnostic Trouble Code (DTC) Detecting Criteria

GENERAL DESCRIPTION

## BA:DTC P0452 EVAPORATIVE EMISSION CONTROL SYSTEM PRESSURE SENSOR LOW INPUT

### 1. OUTLINE OF DIAGNOSIS

Detect the open or short circuit of the fuel tank pressure sensor.  
Judge NG when out of the standard value.

### 2. COMPONENT DESCRIPTION

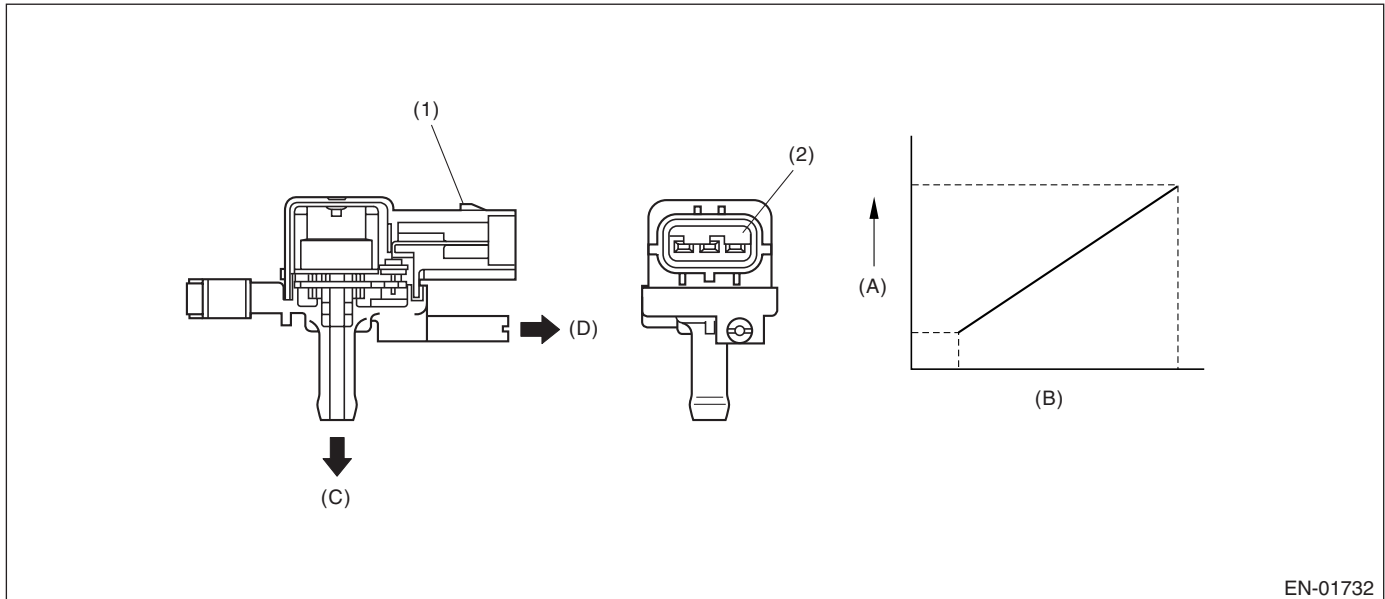

- (1) Connector
- (2) Terminal

- (A) Output voltage
- (B) Input voltage
- (C) To fuel tank
- (D) To atmospheric pressure switching solenoid

### 3. ENABLE CONDITION (USED WITH HIGH SIDE NORMAL/ABNORMAL JUDGMENT)

Secondary Parameters	Enable Conditions
None	

### 4. GENERAL DRIVING CYCLE

Always perform the diagnosis continuously.

### 5. DIAGNOSTIC METHOD

#### • Abnormality Judgment

Judge NG when the continuous time of completing the malfunction criteria below becomes more than 15 seconds.

#### Judgment Value

Malfunction Criteria	Threshold Value
Fuel tank pressure	< -7.33 kPa (-55 mmHg, -2.17 inHg)

**Time Needed for Diagnosis:** 15 seconds

**Malfunction Indicator Light Illumination:** Illuminates as soon as malfunction occurs.

# Diagnostic Trouble Code (DTC) Detecting Criteria

## GENERAL DESCRIPTION

---

### • Normality Judgment

Judge OK when the malfunction criteria below is completed.

#### Judgment Value

Malfunction Criteria	Threshold Value
Fuel tank pressure	$\geq -7.33$ kPa ( $-55$ mmHg, $-2.17$ inHg)

### 6. DTC CLEAR CONDITION

- When the OK idling cycle was completed 40 times in a row
- When "Clear Memory" was performed

### 7. MALFUNCTION INDICATOR LIGHT CLEAR CONDITION

- When the OK driving cycle was completed 3 times in a row
- When "Clear Memory" was performed

### 8. FAIL SAFE

Purge control solenoid valve control: Purge fixation mode is prohibited.

### 9. ECM OPERATION AT DTC SETTING

Memorize the freeze frame data. (For test mode \$02)

# Diagnostic Trouble Code (DTC) Detecting Criteria

GENERAL DESCRIPTION

## BB:DTC P0453 EVAPORATIVE EMISSION CONTROL SYSTEM PRESSURE SENSOR HIGH INPUT

### 1. OUTLINE OF DIAGNOSIS

Detect the breaking/shortage of the fuel tank pressure sensor.  
Judge NG when out of the standard value.

### 2. COMPONENT DESCRIPTION

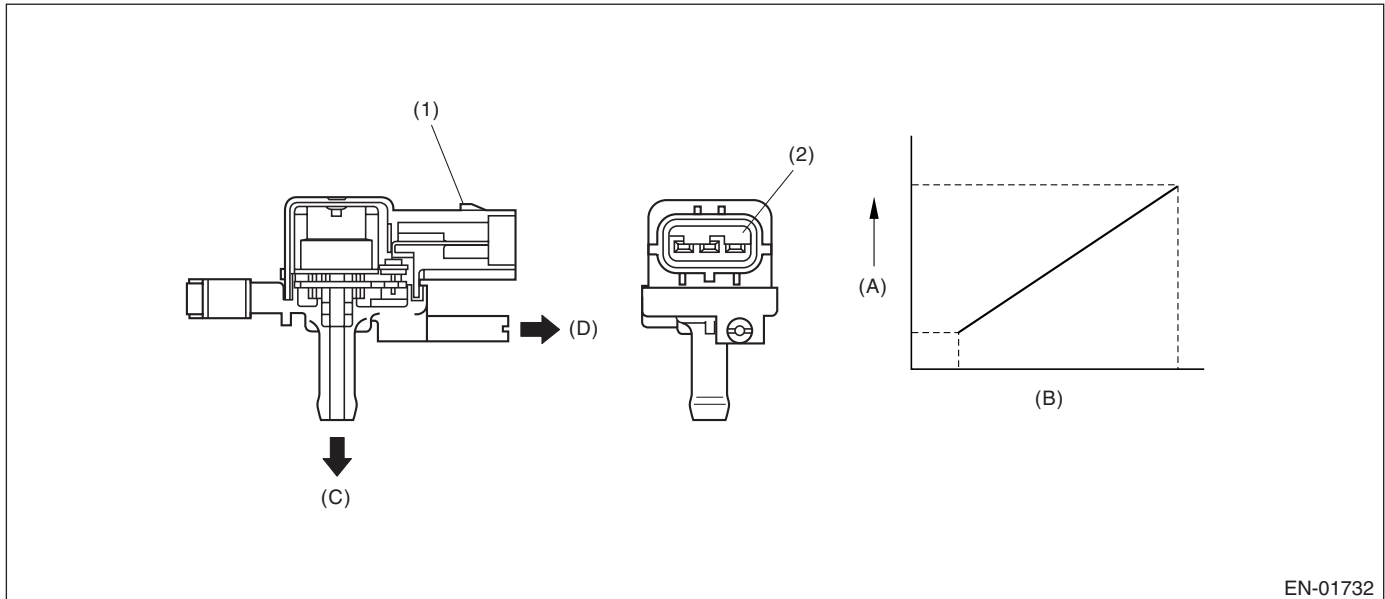

- (1) Connector
- (2) Terminal

- (A) Output voltage
- (B) Input voltage
- (C) To fuel tank
- (D) To atmospheric pressure switching solenoid

### 3. ENABLE CONDITION

Secondary Parameters	Enable Conditions
Continuous time when all conditions are completed.	$\geq 5$ seconds
Vehicle speed	$\geq 2$ km/h (1.24 MPH)
All conditions of EVAP canister purge	Complete
Evaporation gas density learning value	$\leq 0.08$
Main feedback compensation coefficient	$\geq 0.9$
Battery voltage	$\geq 10.9$ V

### 4. GENERAL DRIVING CYCLE

Perform the diagnosis when purging.



# Diagnostic Trouble Code (DTC) Detecting Criteria

## GENERAL DESCRIPTION

### 5. DIAGNOSTIC METHOD

#### • Abnormality Judgment

Judge NG when the continuous time until completing the malfunction criteria below becomes more than 15 seconds.

#### Judgment Value

Malfunction Criteria	Threshold Value
Fuel tank pressure	$\geq 7.33$ kPa (55 mmHg, 2.17 inHg)
Fuel temperature	$< 35^{\circ}\text{C}$ (95°F)
Atmospheric pressure	$\geq 75.1$ kPa (563 mmHg, 22.2 inHg)

**Time Needed for Diagnosis:** 15 seconds

**Malfunction Indicator Light Illumination:** Illuminates as soon as malfunction occurs.

#### • Normality Judgment

Judge OK when the malfunction criteria below is completed.

#### Judgment Value

Malfunction Criteria	Threshold Value
Fuel tank pressure	$\geq 7.33$ kPa (55 mmHg, 2.17 inHg)

### 6. DTC CLEAR CONDITION

- When the OK idling cycle was completed 40 times in a row
- When "Clear Memory" was performed

### 7. MALFUNCTION INDICATOR LIGHT CLEAR CONDITION

- When the OK driving cycle was completed 3 times in a row
- When "Clear Memory" was performed

### 8. FAIL SAFE

Purge control solenoid valve control: Purge fixation mode is prohibited.

### 9. ECM OPERATION AT DTC SETTING

Memorize the freeze frame data. (For test mode \$02)

## BC:DTC P0456 EVAPORATIVE EMISSION CONTROL SYSTEM LEAK DETECTED (VERY SMALL LEAK)

### 1. OUTLINE OF DIAGNOSIS

For detecting conditions, refer to DTC P0442 EVAPORATIVE EMISSION CONTROL SYSTEM LEAK DETECTED (SMALL LEAK). <Ref. to GD(H4DOTC)-112, DTC P0442 EVAPORATIVE EMISSION CONTROL SYSTEM LEAK DETECTED (SMALL LEAK), Diagnostic Trouble Code (DTC) Detecting Criteria.>

## BD:DTC P0457 EVAPORATIVE EMISSION CONTROL SYSTEM LEAK DETECTED (FUEL CAP LOOSE/OFF)

### 1. OUTLINE OF DIAGNOSIS

For detecting conditions, refer to DTC P0442 EVAPORATIVE EMISSION CONTROL SYSTEM LEAK DETECTED (SMALL LEAK). <Ref. to GD(H4DOTC)-112, DTC P0442 EVAPORATIVE EMISSION CONTROL SYSTEM LEAK DETECTED (SMALL LEAK), Diagnostic Trouble Code (DTC) Detecting Criteria.>

# Diagnostic Trouble Code (DTC) Detecting Criteria

GENERAL DESCRIPTION

## BE:DTC P0458 EVAPORATIVE EMISSION CONTROL SYSTEM PURGE CONTROL VALVE CIRCUIT LOW

### 1. OUTLINE OF DIAGNOSIS

Detect open or short circuit of purge control solenoid valve.

Judge NG when ECM output level is different from actual terminal level.

### 2. COMPONENT DESCRIPTION

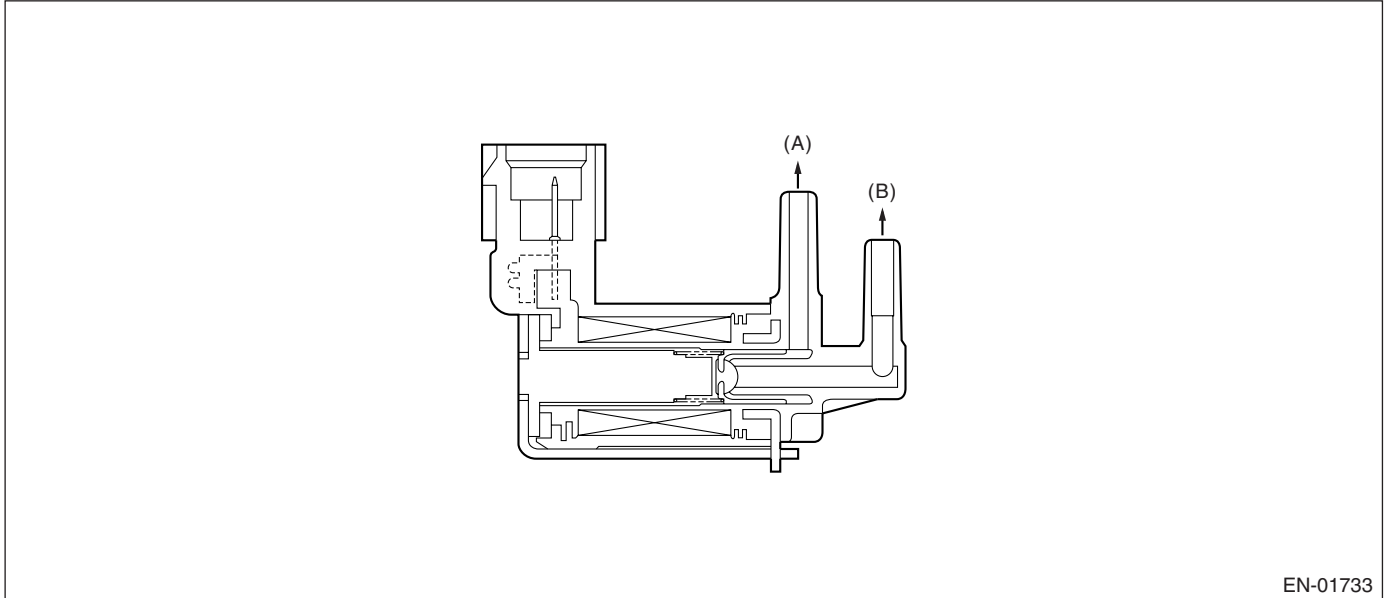

EN-01733

(A) To canister

(B) To intake manifold

### 3. ENABLE CONDITION

Secondary Parameters	Enable Conditions
Ignition switch	ON
Battery voltage	$\geq 10.9$ V
After engine starting	1 second or more

### 4. GENERAL DRIVING CYCLE

Always perform the diagnosis after starting the engine.

### 5. DIAGNOSTIC METHOD

#### • Abnormality Judgment

Judge NG when the continuous time of completing the malfunction criteria below becomes more than the time needed for diagnosis (2.5 seconds).

#### Judgment Value

Malfunction Criteria	Threshold Value
Duty ratio of 'ON'	$< 75\%$
Terminal output voltage	Low

**Time Needed for Diagnosis:** 2.5 seconds

**Malfunction Indicator Light Illumination:** Illuminates as soon as malfunction occurs.

# Diagnostic Trouble Code (DTC) Detecting Criteria

## GENERAL DESCRIPTION

---

### • Normality Judgment

Judge OK and clear NG when the malfunction criterion below is completed.

### Judgment Value

Malfunction Criteria	Threshold Value
Terminal output voltage	High

### 6. DTC CLEAR CONDITION

- When the OK idling cycle was completed 40 times in a row
- When "Clear Memory" was performed

### 7. MALFUNCTION INDICATOR LIGHT CLEAR CONDITION

- When the OK driving cycle was completed 3 times in a row
- When "Clear Memory" was performed

### 8. FAIL SAFE

None

### 9. ECM OPERATION AT DTC SETTING

Memorize the freeze frame data. (For test mode \$02)

# Diagnostic Trouble Code (DTC) Detecting Criteria

GENERAL DESCRIPTION

## BF:DTC P0459 EVAPORATIVE EMISSION CONTROL SYSTEM PURGE CONTROL VALVE CIRCUIT HIGH

### 1. OUTLINE OF DIAGNOSIS

Detect open or short circuit of purge control solenoid valve.

Judge NG when ECM output level is different from actual terminal level.

### 2. COMPONENT DESCRIPTION

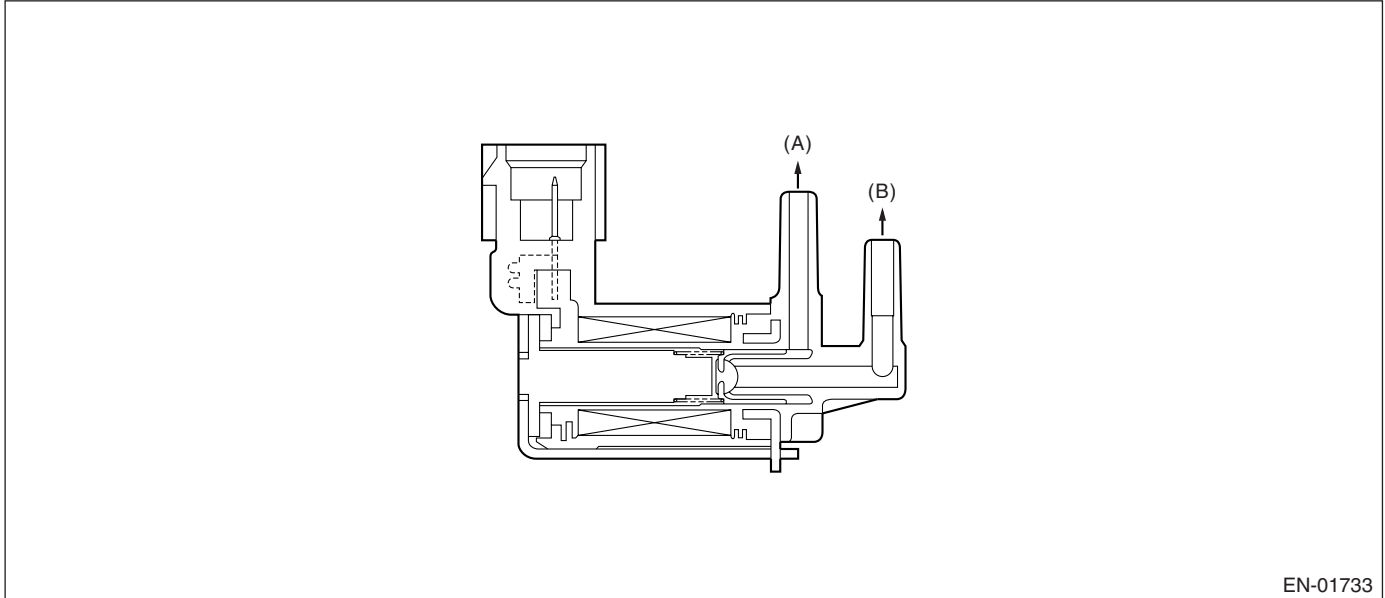

EN-01733

(A) To canister

(B) To intake manifold

### 3. ENABLE CONDITION

Secondary Parameters	Enable Conditions
Ignition switch	ON
Battery voltage	$\geq 10.9$ V
After engine starting	1 second or more

### 4. GENERAL DRIVING CYCLE

Always perform the diagnosis after starting the engine.

### 5. DIAGNOSTIC METHOD

#### • Abnormality Judgment

Judge NG when the continuous time of completing the malfunction criteria below becomes more than the time needed for diagnosis (2.5 seconds).

#### Judgment Value

Malfunction Criteria	Threshold Value
Duty ratio of 'ON'	$\geq 25\%$
Terminal output voltage	High

**Time Needed for Diagnosis:** 2.5 seconds

**Malfunction Indicator Light Illumination:** Illuminates when malfunction occurs in 2 continuous driving cycles.

# Diagnostic Trouble Code (DTC) Detecting Criteria

## GENERAL DESCRIPTION

---

### • Normality Judgment

Judge OK and clear NG when the malfunction criterion below is completed.

### Judgment Value

Malfunction Criteria	Threshold Value
Terminal output voltage	Low

### 6. DTC CLEAR CONDITION

- When the OK idling cycle was completed 40 times in a row
- When "Clear Memory" was performed

### 7. MALFUNCTION INDICATOR LIGHT CLEAR CONDITION

- When the OK driving cycle was completed 3 times in a row
- When "Clear Memory" was performed

### 8. FAIL SAFE

None

### 9. ECM OPERATION AT DTC SETTING

Memorize the freeze frame data. (For test mode \$02)

# Diagnostic Trouble Code (DTC) Detecting Criteria

GENERAL DESCRIPTION

## BG:DTC P0461 FUEL LEVEL SENSOR CIRCUIT RANGE/PERFORMANCE

### 1. OUTLINE OF DIAGNOSIS

Detect the malfunction of fuel level sensor output property.

Judge NG when the fuel level does not vary whereas it seemed to vary be in a usual driving speed.

### 2. COMPONENT DESCRIPTION

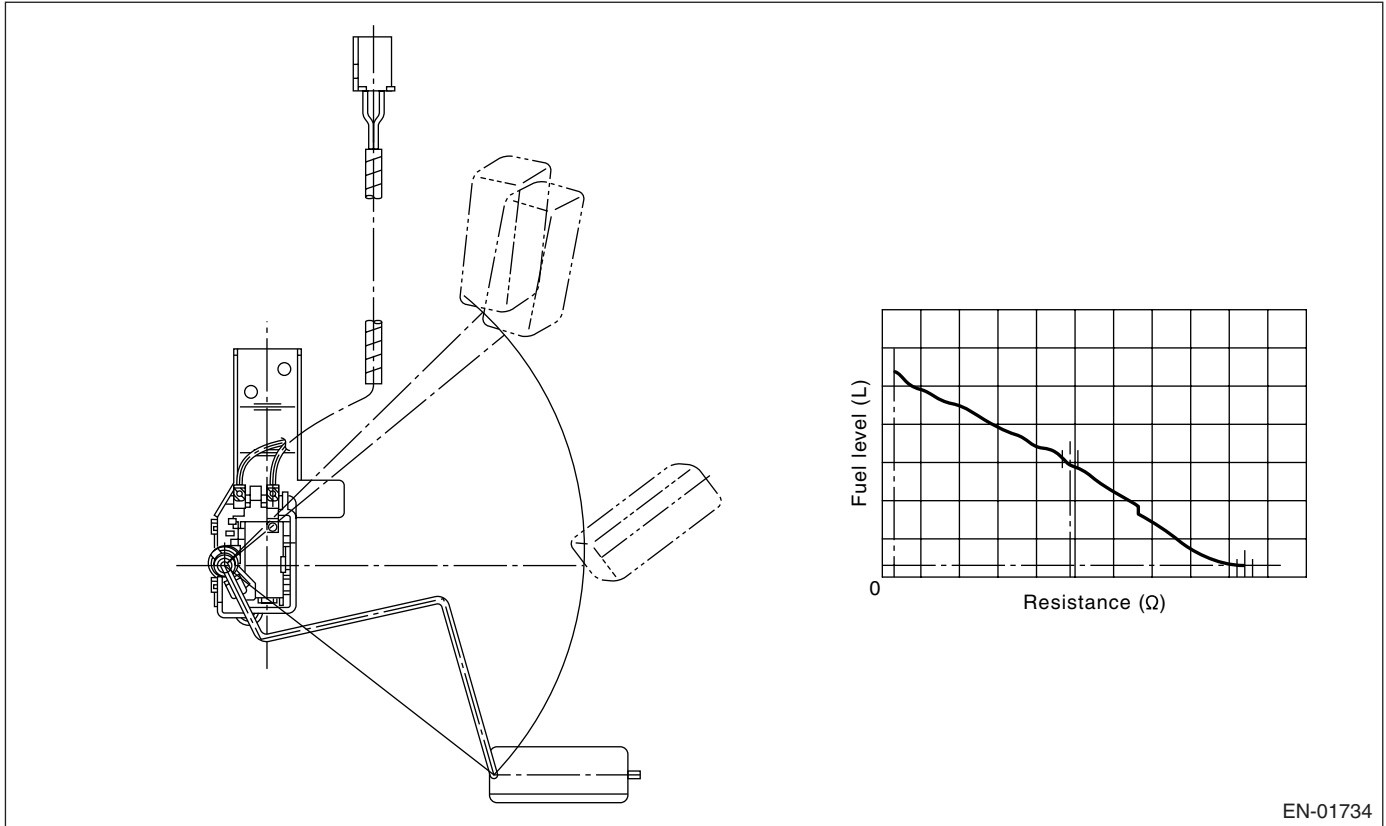

EN-01734

### 3. ENABLE CONDITION

Secondary Parameters	Enable Conditions
None	

### 4. GENERAL DRIVING CYCLE

Always perform the diagnosis continuously.

### 5. DIAGNOSTIC METHOD

#### • Abnormality Judgment

Judge NG when the malfunction criteria below are completed.

#### Judgment Value

Malfunction Criteria	Threshold Value
Accumulated amount of intake air	> 331 kg (729.7 lb)
Max. – Min. fuel level output	< 2.6 ℓ (0.69 US gal, 0.57 Imp gal)
Battery voltage	≥ 10.9 V
Engine speed	< 6,500 rpm

**Time Needed for Diagnosis:** To be determined.

**Malfunction Indicator Light Illumination:** Illuminates when malfunction occurs in 2 continuous driving cycles.

# Diagnostic Trouble Code (DTC) Detecting Criteria

## GENERAL DESCRIPTION

---

### • Normality Judgment

Judge OK and clear the NG when the malfunction criteria below are completed.

### Judgment Value

Malfunction Criteria	Threshold Value
Accumulated amount of intake air	> 331 kg (729.7 lb)
Max.– Min. fuel level output	≥ 2.6 ℓ (0.69 US gal, 0.57 Imp gal)
Battery voltage	≥ 10.9 V
Engine speed	< 6,500 rpm

### 6. DTC CLEAR CONDITION

- When the OK idling cycle was completed 40 times in a row
- When “Clear Memory” was performed

### 7. MALFUNCTION INDICATOR LIGHT CLEAR CONDITION

- When the OK driving cycle was completed 3 times in a row
- When “Clear Memory” was performed

### 8. FAIL SAFE

None

### 9. ECM OPERATION AT DTC SETTING

Memorize the freeze frame data. (For test mode \$02)

# Diagnostic Trouble Code (DTC) Detecting Criteria

GENERAL DESCRIPTION

## BH:DTC P0462 FUEL LEVEL SENSOR CIRCUIT LOW INPUT

### 1. OUTLINE OF DIAGNOSIS

Detect the open or short circuit of fuel level sensor. Judge NG when out of the standard value.

### 2. COMPONENT DESCRIPTION

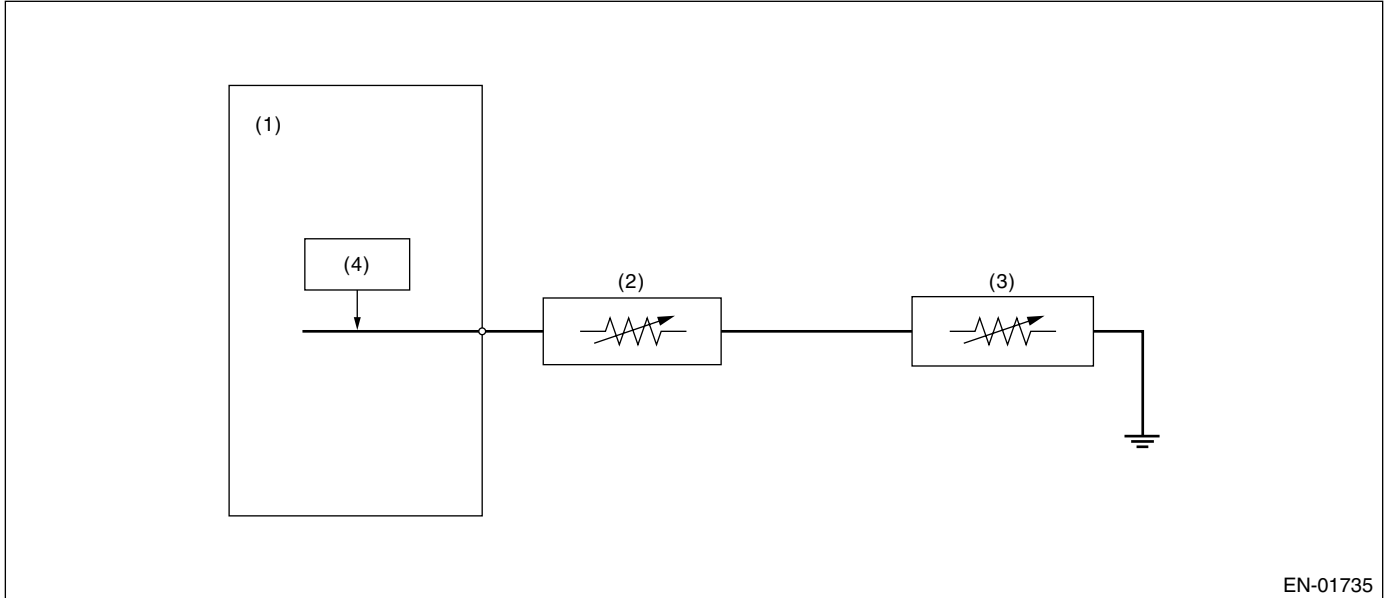

- (1) Engine control module (ECM)
- (2) Fuel level sensor
- (3) Fuel sub level sensor
- (4) Detecting circuit

### 3. ENABLE CONDITION

Secondary Parameters	Enable Conditions
None	

### 4. GENERAL DRIVING CYCLE

Always perform the diagnosis continuously

### 5. DIAGNOSTIC METHOD

#### • Abnormality Judgment

Judge NG when the continuous time of completing the malfunction criteria below becomes more than the time needed for diagnosis (2.5 seconds).

#### Judgment Value

Malfunction Criteria	Threshold Value
Ignition switch	ON
Battery voltage	$\geq 10.9$ V
After engine starting	3 seconds or more $< 0.01$ V

**Time Needed for Diagnosis:** 2.5 seconds

**Malfunction Indicator Light Illumination:** Illuminates when malfunction occurs in 2 continuous driving cycles.



# Diagnostic Trouble Code (DTC) Detecting Criteria

## GENERAL DESCRIPTION

---

### • Normality Judgment

Judge OK and clear the NG when the malfunction criteria below are completed.

### Judgment Value

Malfunction Criteria	Threshold Value
Ignition switch	ON
Battery voltage	$\geq 10.9$ V
After engine starting	3 seconds or more
	$\geq 0.01$ V

### 6. DTC CLEAR CONDITION

- When the OK idling cycle was completed 40 times in a row
- When "Clear Memory" was performed

### 7. MALFUNCTION INDICATOR LIGHT CLEAR CONDITION

- When the OK driving cycle was completed 3 times in a row
- When "Clear Memory" was performed

### 8. FAIL SAFE

None

### 9. ECM OPERATION AT DTC SETTING

Memorize the freeze frame data. (For test mode \$02)

# Diagnostic Trouble Code (DTC) Detecting Criteria

GENERAL DESCRIPTION

## BI: DTC P0463 FUEL LEVEL SENSOR CIRCUIT HIGH INPUT

### 1. OUTLINE OF DIAGNOSIS

Detect the open or short circuit of fuel level sensor. Judge NG when out of the standard value.

### 2. COMPONENT DESCRIPTION

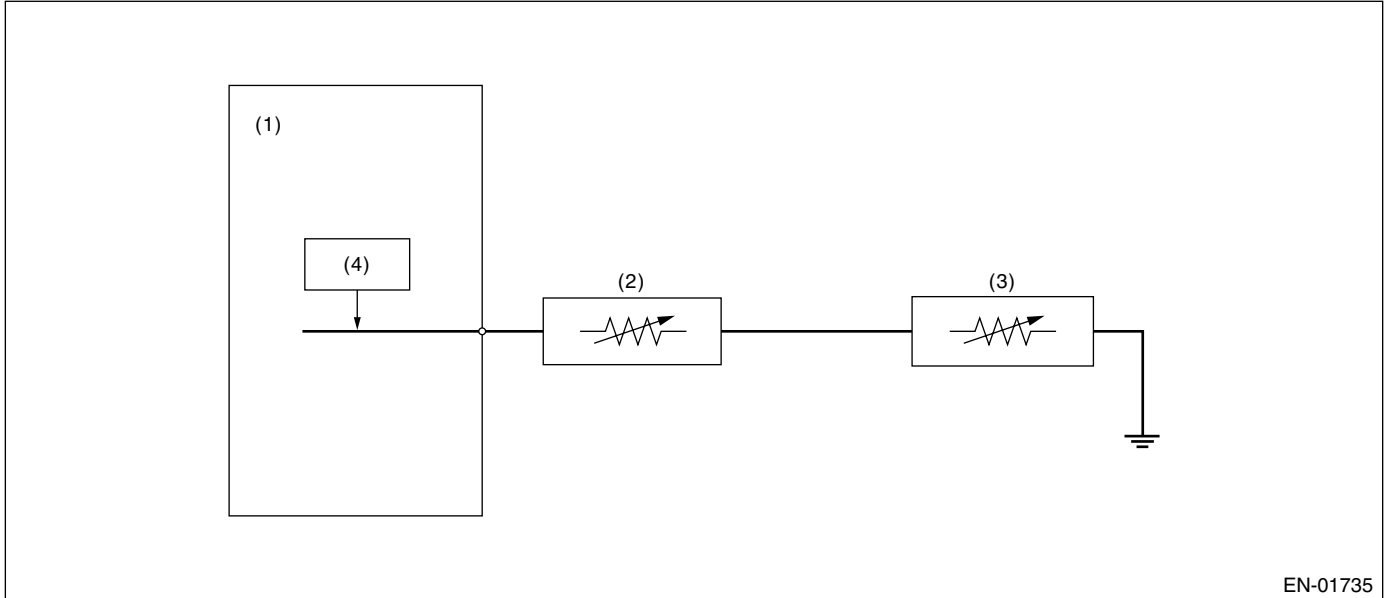

- (1) Engine control module (ECM)
- (2) Fuel level sensor
- (3) Fuel sub level sensor
- (4) Detecting circuit

### 3. ENABLE CONDITION

Secondary Parameters	Enable Conditions
None	

### 4. GENERAL DRIVING CYCLE

Always perform the diagnosis continuously

### 5. DIAGNOSTIC METHOD

#### • Abnormality Judgment

Judge NG when the continuous time of completing the malfunction criteria below becomes more than the time needed for diagnosis (one second).

#### Judgment Value

Malfunction Criteria	Threshold Value
Ignition switch	ON
Battery voltage	$\geq 10.9$ V
After engine starting	3 seconds or more
Output voltage	$\geq 4.95$ V

**Time Needed for Diagnosis:** 1 second

**Malfunction Indicator Light Illumination:** Illuminates when malfunction occurs in 2 continuous driving cycles.

# Diagnostic Trouble Code (DTC) Detecting Criteria

## GENERAL DESCRIPTION

---

### • Normality Judgment

Judge OK and clear the NG when the malfunction criteria below are completed.

### Judgment Value

Malfunction Criteria	Threshold Value
Ignition switch	ON
Battery voltage	$\geq 10.9$ V
After engine starting	3 seconds or more
Output voltage	$< 4.95$ V

### 6. DTC CLEAR CONDITION

- When the OK idling cycle was completed 40 times in a row
- When "Clear Memory" was performed

### 7. MALFUNCTION INDICATOR LIGHT CLEAR CONDITION

- When the OK driving cycle was completed 3 times in a row
- When "Clear Memory" was performed

### 8. FAIL SAFE

None

### 9. ECM OPERATION AT DTC SETTING

Memorize the freeze frame data. (For test mode \$02)

# Diagnostic Trouble Code (DTC) Detecting Criteria

GENERAL DESCRIPTION

## BJ:DTC P0464 FUEL LEVEL SENSOR CIRCUIT INTERMITTENT

### 1. OUTLINE OF DIAGNOSIS

Detect the malfunction of unstable output from fuel level sensor caused by noise.

Judge NG when the max. value and cumulative value of output voltage variation of fuel level sensor is larger than the threshold value.

### 2. ENABLE CONDITION

Secondary Parameters	Enable Conditions
Engine speed	≥ 500 rpm
After engine starting	1 second or more
Ignition switch	ON
Battery voltage	> 10.9 V
Idle switch	ON
Fuel level	9 ↔ 51 ℓ (2.4 ↔ 13.4 US gal, 1.98 ↔ 11.2 Imp gal)
Vehicle speed = 0 km/h (0 MPH)	10 seconds or more

### 3. GENERAL DRIVING CYCLE

- Perform the diagnosis continuously in idling condition.
- Pay attention to the fuel level.

# Diagnostic Trouble Code (DTC) Detecting Criteria

## GENERAL DESCRIPTION

### 4. DIAGNOSTIC METHOD

Calculate the Max. value (delflmax) and cumulative value (sumfl) of output voltage variation of fuel level sensor during 4,369 milliseconds. Judge it normal when both max. and cumulative values are not over the threshold value. Otherwise, when either of them is over the threshold value, count the diagnosis counter up. And judge NG if the counter indicated 6 counts.

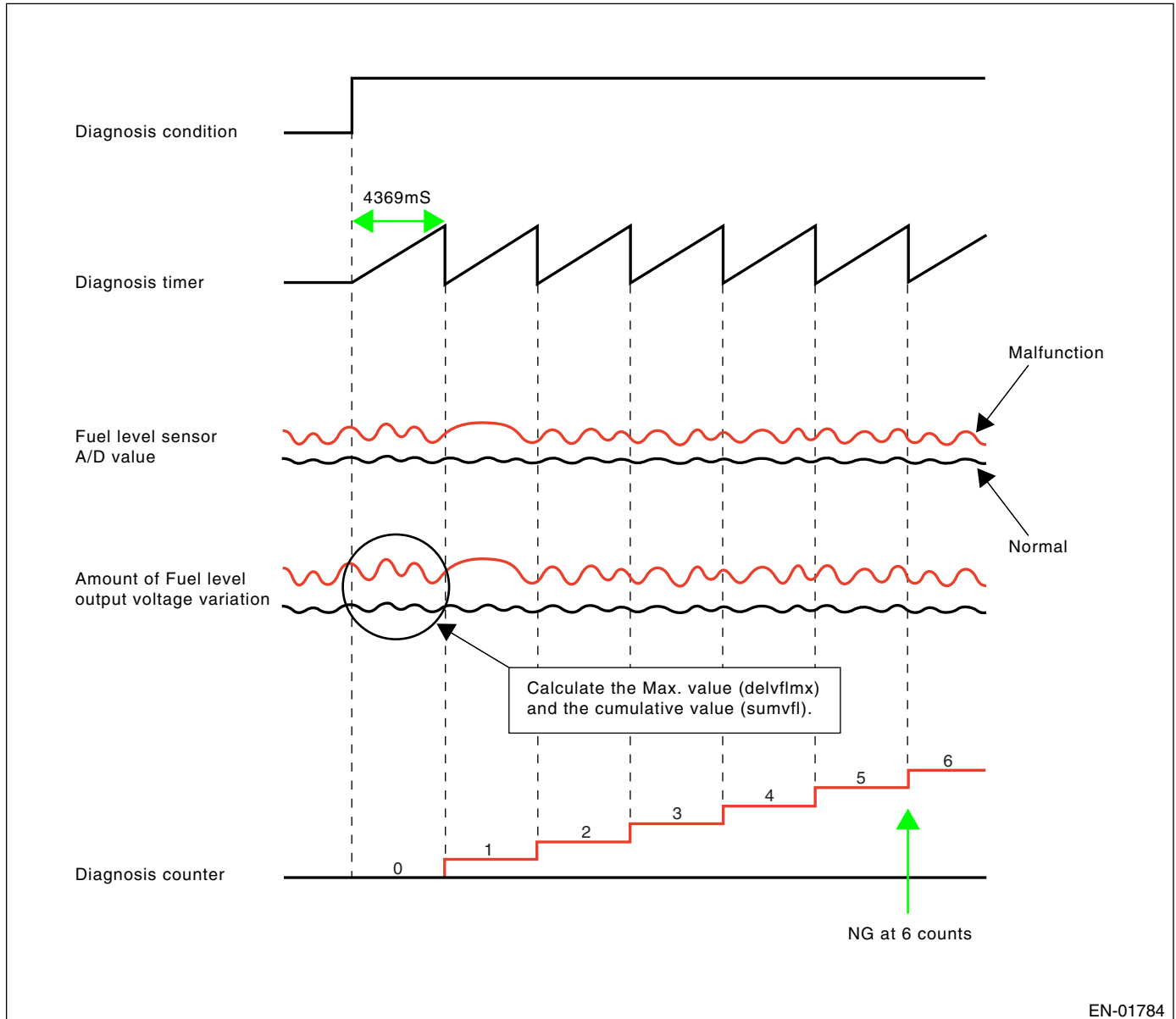

EN-01784

#### • Abnormality Judgment

Judge NG when the malfunction criteria below are completed.

#### Judgment Value

Malfunction Criteria	Threshold Value
Integrated times of the condition reaching follows, $DELFLMAX \geq 0.2 \text{ V}$ or $SUMFL \geq 5 \text{ V}$ where, DELFLMAX is Max. deviation of sensor output during 4,369 milliseconds. SUMFL is integrated value of sensor output deviation during 4,369 milliseconds.	$\geq 6$ times

# Diagnostic Trouble Code (DTC) Detecting Criteria

GENERAL DESCRIPTION

Do not count the diagnosis counter up when the following conditions are completed during 4,369 milliseconds.

Max – Min of tank pressure during 4,369 milliseconds	$\geq 0.05$ kPa (0.375 mmHg, 0.02 inHg)
Max – Min of battery voltage during 4,369 milliseconds	$\geq 0.4$ V

**Time Needed for Diagnosis:** 4,369 milliseconds  $\times$  6 times

**Malfunction Indicator Light Illumination:** Illuminates when malfunction occurs in 2 continuous driving cycles.

## • Normality Judgment

Judge OK and clear the NG when the malfunction criteria below are completed.

## Judgment Value

Malfunction Criteria	Threshold Value
DELFLMAX	$< 0.2$ V
SUMFL Where, DELFLMAX is Max. deviation of sensor output during 4,369 milliseconds. SUMFL is integrated value of sensor output deviation during 4,369 milliseconds.	$< 5$ V

## 5. DTC CLEAR CONDITION

- When the OK idling cycle was completed 40 times in a row
- When "Clear Memory" was performed

## 6. MALFUNCTION INDICATOR LIGHT CLEAR CONDITION

- When the OK driving cycle was completed 3 times in a row
- When "Clear Memory" was performed

## 7. FAIL SAFE

None

## 8. ECM OPERATION AT DTC SETTING

Memorize the freeze frame data. (For test mode \$02)

# Diagnostic Trouble Code (DTC) Detecting Criteria

## GENERAL DESCRIPTION

### BK:DTC P0483 COOLING FAN RATIONALITY CHECK

#### 1. OUTLINE OF DIAGNOSIS

Detect the function abnormality of the radiator fan.

Judge NG when the engine coolant temperature slowly decreases even when the radiator fan is rotating.

#### 2. ENABLE CONDITION

Diagnostic enable condition is completed if the radiator fan changes from OFF to ON when all of the conditions below are completed. When one of the conditions below is not completed, the diagnostic enable condition is not completed.

Secondary Parameters	Enable Conditions
Engine Speed	600 — 900 rpm
Idle switch	ON
Vehicle speed	< 2 km/h (1.2 MPH)
Battery voltage	≥ 0.9 V

#### 3. GENERAL DRIVING CYCLE

Perform the diagnosis continuously when the radiator fan changes from OFF to ON when idling.

#### 4. DIAGNOSTIC METHOD

##### • Abnormality Judgment

Judge NG when the continuous time of completing the malfunction criteria below becomes more than 5 minutes.

##### Judgment Value

Malfunction Criteria	Threshold Value
Engine coolant temperature	≥ 96°C (204.8°F)
Engine coolant temperature sensor A/D value – Engine coolant temperature sensor A/D value Min. value (Min. value with radiator fan OFF → ON)	< 15 mV (Approx. 1°C (1.8°F))

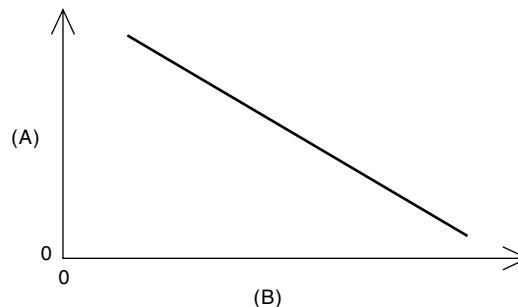

EN-01737

(A) Engine coolant temperature °C (°F)

(B) A/D value (V)

**Time Needed for Diagnosis:** 5 minutes

# Diagnostic Trouble Code (DTC) Detecting Criteria

GENERAL DESCRIPTION

**Malfunction Indicator Light Illumination:** Illuminates when malfunction occurs in 2 continuous driving cycles.

## • Normality Judgment

Judge OK and clear NG when the malfunction criteria below are completed.

## Judgment Value

Malfunction Criteria	Threshold Value
Engine coolant temperature sensor A/D value – Engine coolant temperature sensor A/D value Min. value (Min. value with radiator fan OFF → ON)	≥ 15 mV (Approx. 1°C (1.8°F))

## 5. DTC CLEAR CONDITION

- When the OK idling cycle was completed 40 times in a row
- When “Clear Memory” was performed

## 6. MALFUNCTION INDICATOR LIGHT CLEAR CONDITION

- When the OK driving cycle was completed 3 times in a row
- When “Clear Memory” was performed

## 7. FAIL SAFE

None

## 8. ECM OPERATION AT DTC SETTING

Memorize the freeze frame data. (For test mode \$02)



# Diagnostic Trouble Code (DTC) Detecting Criteria

## GENERAL DESCRIPTION

### BL:DTC P0502 VEHICLE SPEED SENSOR CIRCUIT LOW INPUT

#### 1. OUTLINE OF DIAGNOSIS

Detect the open or short circuit of vehicle speed sensor.

Judge NG when low vehicle speed (0 km/h (0 MPH)) remains whereas it seemed to be in a usual driving speed.

#### 2. ENABLE CONDITION

Secondary Parameters	Enable Conditions
Engine speed	< 4,000 rpm
Fuel cut in decel.	Operating
Battery voltage	≥ 10.9 V

#### 3. GENERAL DRIVING CYCLE

Perform the diagnosis continuously during fuel cut in deceleration.

#### 4. DIAGNOSTIC METHOD

Judge NG when the continuous time of completing the malfunction criteria below becomes more than 4 seconds. Judge OK and clear the NG when the malfunction criteria below are not completed.

##### Judgment Value

Malfunction Criteria	Threshold Value
Vehicle speed	< 1

**Time Needed for Diagnosis:** 4 seconds

**Malfunction Indicator Light Illumination:** Illuminates as soon as the malfunction occurs.

#### 5. DTC CLEAR CONDITION

- When the OK idling cycle was completed 40 times in a row
- When "Clear Memory" was performed

#### 6. MALFUNCTION INDICATOR LIGHT CLEAR CONDITION

- When the OK driving cycle was completed 3 times in a row
- When "Clear Memory" was performed

#### 7. FAIL SAFE

- Throttle position sensor signal process: All closed points learning / Not allowed to increase.
- Vehicle speed sensor signal process: Vehicle speed = 0 km/h (0 MPH)
- Fuel cut control: Vehicle speed = 0 km/h (0 MPH) / Not allowed to carry out the fuel cut. High vehicle speed / Not allowed to carry out the fuel cut.
- ISC open loop compensation: Fix the open loop compensation at 5%
- ISC feedback control: Not allowed to calculate the amount of ISC feedback.
- Air conditioner control: Not allowed to resume the air conditioner that is cut with the throttle fully opened.
- Radiator fan control: Both main and sub fan are in High driving.

#### 8. ECM OPERATION AT DTC SETTING

Memorize the freeze frame data. (For test mode \$02)

# Diagnostic Trouble Code (DTC) Detecting Criteria

GENERAL DESCRIPTION

## BM:DTC P0503 VEHICLE SPEED SENSOR INTERMITTENT/ERRATIC/HIGH

### 1. OUTLINE OF DIAGNOSIS

Detect the open or short circuit of vehicle speed sensor.

Judge NG when high vehicle speed (240 km/h (149.1 MPH) or more) remains whereas it seemed to be in a usual driving speed.

### 2. ENABLE CONDITION

Secondary Parameters	Enable Conditions
Engine speed	< 4,000 rpm
Fuel cut in decel.	Operating
Battery voltage	≥ 10.9 V

### 3. GENERAL DRIVING CYCLE

Perform the diagnosis continuously during fuel cut in deceleration.

### 4. DIAGNOSTIC METHOD

Judge NG when the cumulative time of completing the malfunction criteria below becomes more than 4 seconds. Judge OK and clear the NG when the malfunction criteria below are not completed.

#### Judgment Value

Malfunction Criteria	Threshold Value
Vehicle speed	≥ 240

**Time Needed for Diagnosis:** 4 seconds

**Malfunction Indicator Light Illumination:** Illuminates as soon as the malfunction occurs.

### 5. DTC CLEAR CONDITION

- When the OK idling cycle was completed 40 times in a row
- When "Clear Memory" was performed

### 6. MALFUNCTION INDICATOR LIGHT CLEAR CONDITION

- When the OK driving cycle was completed 3 times in a row
- When "Clear Memory" was performed

### 7. FAIL SAFE

- Throttle position sensor signal process: All closed points learning / Not allowed to increase.
- Vehicle speed sensor signal process: Vehicle speed = 0 km/h (0 MPH)
- Fuel cut control: Vehicle speed = 0 km/h (0 MPH) / Not allowed to carry out the fuel cut. High vehicle speed / Not allowed to carry out the fuel cut.
- ISC open loop compensation: Fix the open loop compensation at 5%
- ISC feedback control: Not allowed to calculate the amount of ISC feedback.
- Air conditioner control: Not allowed to resume the air conditioner that is cut with the throttle fully opened.
- Radiator fan control: Both main and sub fan are in High driving.

### 8. ECM OPERATION AT DTC SETTING

Memorize the freeze frame data. (For test mode \$02)

# Diagnostic Trouble Code (DTC) Detecting Criteria

## GENERAL DESCRIPTION

### BN:DTC P0506 IDLE CONTROL SYSTEM RPM LOWER THAN EXPECTED

#### 1. OUTLINE OF DIAGNOSIS

Detect the malfunction that actual engine speed is not close to target engine speed during idling.  
Judge NG when actual engine speed is not close to target engine speed during idling.

#### 2. COMPONENT DESCRIPTION

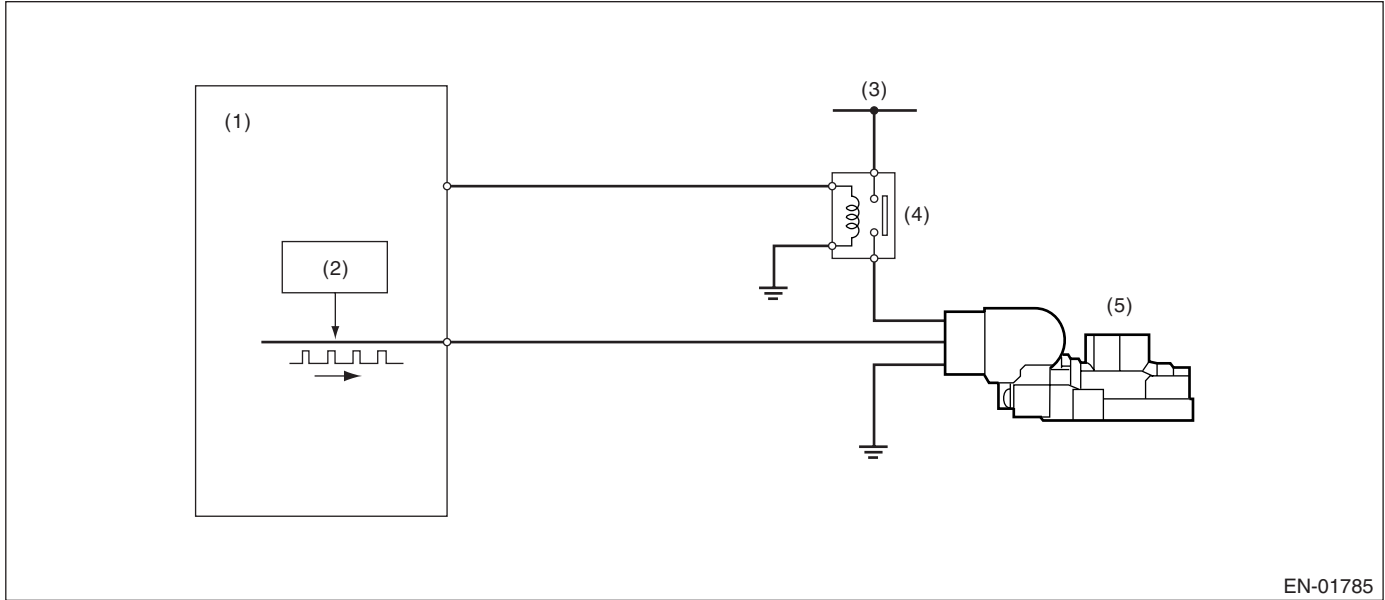

- (1) Engine control module (ECM)
- (2) Detecting circuit
- (3) Battery voltage
- (4) Main relay
- (5) Idle air control solenoid valve

#### 3. ENABLE CONDITION

Secondary Parameters	Enable Conditions
Engine coolant temperature	≥ 75°C (167°F)
Battery voltage	≥ 10.9 V
Atmospheric pressure	> 75.1 kPa (563 mmHg, 22.2 inHg)
Fuel level	≥ 9 ℓ (2.38 US gal, 1.98 Imp gal)
After engine starting	10 seconds or more
Feedback in ISC	In operation
Measured lambda	0.90 ↔ 1.1
After air condition switching ON-OFF, OFF-ON	5 seconds or more
After in-manifold pressure change more than 4 kPa (30 mmHg, 1.2 inHg)	> 5 seconds
After neutral switch ON-OFF event	> 5 seconds
Vehicle speed	0 km/h (0 MPH)

#### 4. GENERAL DRIVING CYCLE

Always perform diagnosis during idling after engine starting.

# Diagnostic Trouble Code (DTC) Detecting Criteria

GENERAL DESCRIPTION

## 5. DIAGNOSTIC METHOD

### • Abnormality Judgment

Judge NG when the cumulative time of completing the malfunction criterion below becomes more than the time needed for diagnosis (10 seconds × 3 times).

### Judgment Value

Malfunction Criteria	Threshold Value
Actual – target engine speed	< –100 rpm
Feedback correction for idle air control solenoid valve	Max.

**Time Needed for Diagnosis:** 10 seconds × 3 times

**Malfunction Indicator Light Illumination:** Illuminates when malfunction occurs in 2 continuous driving cycles.

### • Normality Judgment

Judge OK and clear NG when the continuous time of completing the malfunction criterion below becomes more than the time needed for diagnosis (10 seconds).

### Judgment Value

Malfunction Criteria	Threshold Value
Actual – target engine speed	≥ –100 rpm

## 6. DTC CLEAR CONDITION

- When the OK idling cycle was completed 40 times in a row
- When “Clear Memory” was performed

## 7. MALFUNCTION INDICATOR LIGHT CLEAR CONDITION

- When the OK driving cycle was completed 3 times in a row
- When “Clear Memory” was performed

## 8. FAIL SAFE

Judgment of heavy fuel: Not allowed to make the judgment of heavy fuel.

## 9. ECM OPERATION AT DTC SETTING

Memorize the freeze frame data. (For test mode \$02)

# Diagnostic Trouble Code (DTC) Detecting Criteria

## GENERAL DESCRIPTION

### BO:DTC P0507 IDLE CONTROL SYSTEM RPM HIGHER THAN EXPECTED

#### 1. OUTLINE OF DIAGNOSIS

Detect the malfunction that actual engine speed is not close to target engine speed during idling.  
Judge NG when actual engine speed is not close to target engine speed during idling.

#### 2. COMPONENT DESCRIPTION

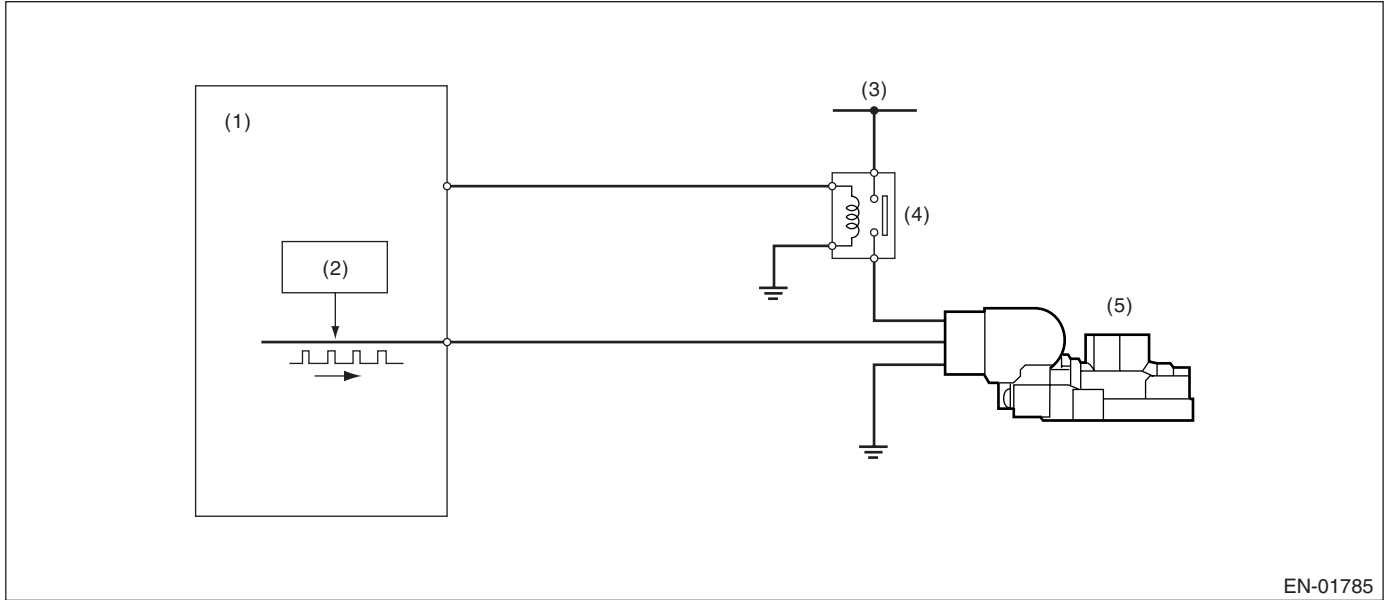

- (1) Engine control module (ECM)
- (2) Detecting circuit
- (3) Battery voltage
- (4) Main relay
- (5) Idle air control solenoid valve

#### 3. ENABLE CONDITION

Secondary Parameters	Enable Conditions
Engine coolant temperature	≥ 75°C (167°F)
Battery voltage	≥ 10.9 V
Atmospheric pressure	> 75.1 kPa (563 mmHg, 22.2 inHg)
Fuel level	≥ 9 ℓ (2.38 US gal, 1.98 Imp gal)
After engine starting	10 seconds or more
Feedback in ISC	In operation
Lambda	0.90 ↔ 1.1
After air condition switching ON-OFF, OFF-ON	5 seconds or more
After in-manifold pressure change more than 4 kPa (30 mmHg, 1.2 inHg)	> 5 seconds
After neutral switch ON-OFF event	> 5 seconds
Vehicle speed	0 km/h (0 MPH)

#### 4. GENERAL DRIVING CYCLE

Always perform diagnosis during idling after engine starting.

# Diagnostic Trouble Code (DTC) Detecting Criteria

GENERAL DESCRIPTION

## 5. DIAGNOSTIC METHOD

### • Abnormality Judgment

Judge NG when the continuous time of completing the malfunction criterion below becomes more than the time needed for diagnosis (10 seconds × 3 times).

### Judgment Value

Malfunction Criteria	Threshold Value
Actual – target eng. speed	≥ 200 rpm
Feedback correction for idle air control solenoid valve	Min.

**Time Needed for Diagnosis:** 10 seconds × 3 times

**Malfunction Indicator Light Illumination:** Illuminates when malfunction occurs in 2 continuous driving cycles.

### • Normality Judgment

Judge OK and clear NG when the continuous time of completing the malfunction criterion below becomes more than the time needed for diagnosis (10 seconds).

### Judgment Value

Malfunction Criteria	Threshold Value
Actual – target eng. speed	< 200 rpm

## 6. DTC CLEAR CONDITION

- When the OK idling cycle was completed 40 times in a row
- When “Clear Memory” was performed

## 7. MALFUNCTION INDICATOR LIGHT CLEAR CONDITION

- When the OK driving cycle was completed 3 times in a row
- When “Clear Memory” was performed

## 8. FAIL SAFE

Judgment of heavy fuel: Not allowed to make the judgment of heavy fuel.

## 9. ECM OPERATION AT DTC SETTING

Memorize the freeze frame data. (For test mode \$02)

# Diagnostic Trouble Code (DTC) Detecting Criteria

## GENERAL DESCRIPTION

### BP:DTC P0508 IDLE CONTROL SYSTEM CIRCUIT LOW

#### 1. OUTLINE OF DIAGNOSIS

Detect open or short circuit in idle air control solenoid valve.  
 Period of idle air control solenoid valve is 4 milliseconds and it is too short.  
 Judge OK/NG in accordance with the number of change of OFF to ON signal.

#### 2. COMPONENT DESCRIPTION

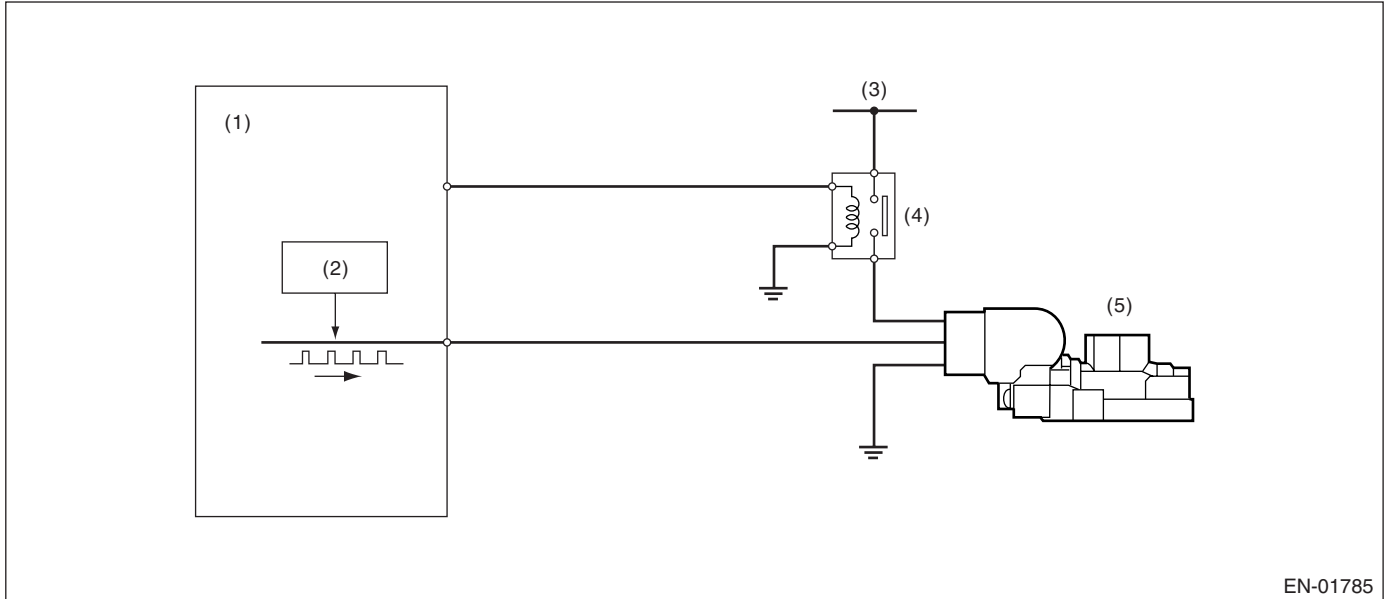

EN-01785

- (1) Engine control module (ECM)
- (2) Detecting circuit
- (3) Battery voltage
- (4) Main relay
- (5) Idle air control solenoid valve

#### 3. ENABLE CONDITION

Secondary Parameters	Enable Conditions
After engine starting	1 second or more
Idle air control solenoid valve duty ratio	5 — 95%
Battery voltage	$\geq 10.9$ V

#### 4. GENERAL DRIVING CYCLE

Perform the diagnosis after starting the engine.

#### 5. DIAGNOSTIC METHOD

Judge NG when the malfunction criteria below are completed. Judge OK and clear NG when the malfunction criteria below are not completed.

##### Judgment Value

Malfunction Criteria	Threshold Value
Number of change that idle air control solenoid valve signal during 64 milliseconds.	$\leq 8$ (160 at normal since the cycle is 4 milliseconds)

**Time Needed for Diagnosis:** 64 milliseconds

**Malfunction Indicator Light Illumination:** Illuminates as soon as malfunction occurs.

## Diagnostic Trouble Code (DTC) Detecting Criteria

GENERAL DESCRIPTION

### 6. DTC CLEAR CONDITION

- When the OK idling cycle was completed 40 times in a row
- When "Clear Memory" was performed

### 7. MALFUNCTION INDICATOR LIGHT CLEAR CONDITION

- When the OK driving cycle was completed 3 times in a row
- When "Clear Memory" was performed

### 8. FAIL SAFE

- Idle air control solenoid valve feedback correction: Not allowed to calculate ifb (idle air control solenoid valve feedback amount)
- Fuel shut-off: Shut-off fuel for only #1 and #2 cylinder, or for all cylinder in accordance with vehicle speed, engine speed, throttle position
- Judgment of heavy fuel: Not allowed to make the judgment of heavy fuel

### 9. ECM OPERATION AT DTC SETTING

Memorize the freeze frame data. (For test mode \$02)



# Diagnostic Trouble Code (DTC) Detecting Criteria

## GENERAL DESCRIPTION

### BQ:DTC P0509 IDLE CONTROL SYSTEM CIRCUIT HIGH

#### 1. OUTLINE OF DIAGNOSIS

Detect open or short circuit in idle air control solenoid valve.  
 Period of idle air control solenoid valve is 4 milliseconds and it is too short.  
 Judge OK/NG in accordance with the number of change of OFF to ON signal.

#### 2. COMPONENT DESCRIPTION

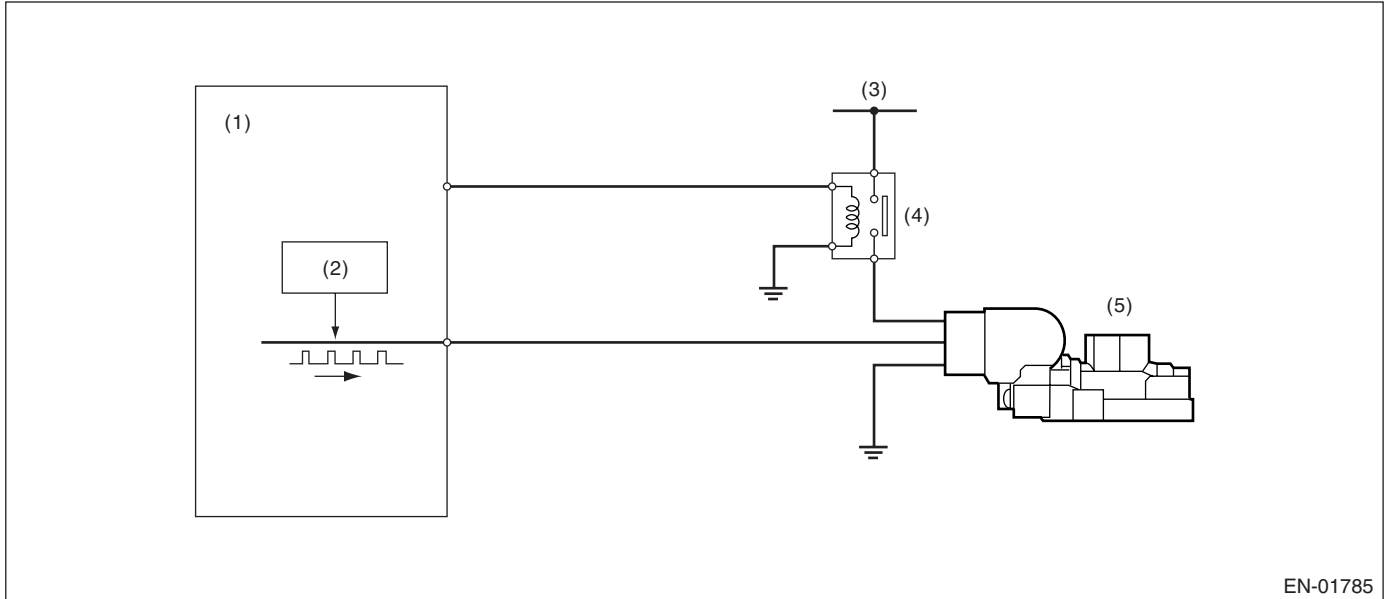

- (1) Engine control module (ECM)
- (2) Detecting circuit
- (3) Battery voltage
- (4) Main relay
- (5) Idle air control solenoid valve

#### 3. ENABLE CONDITION

Secondary Parameters	Enable Conditions
After engine starting	1 second or more
Idle air control solenoid valve duty ratio	5 — 95%
Battery voltage	≥ 10.9 V

#### 4. GENERAL DRIVING CYCLE

Perform the diagnosis after starting the engine.

#### 5. DIAGNOSTIC METHOD

Judge NG when the malfunction criteria below are completed. Judge OK and clear NG when the malfunction criteria below are not completed.

##### Judgment Value

Malfunction Criteria	Threshold Value
Number of change that idle air control solenoid valve signal during 64 milliseconds	≥ 225 (160 at normal since the cycle is 4 milliseconds)

**Time Needed for Diagnosis:** 64 milliseconds

**Malfunction Indicator Light Illumination:** Illuminates as soon as malfunction occurs.

## Diagnostic Trouble Code (DTC) Detecting Criteria

GENERAL DESCRIPTION

### 6. DTC CLEAR CONDITION

- When the OK idling cycle was completed 40 times in a row
- When "Clear Memory" was performed

### 7. MALFUNCTION INDICATOR LIGHT CLEAR CONDITION

- When the OK driving cycle was completed 3 times in a row
- When "Clear Memory" was performed

### 8. FAIL SAFE

- Idle air control solenoid valve feedback correction: Not allowed to calculate ifb (idle air control solenoid valve feedback amount)
- Fuel shut-off: Shut-off fuel for only #1 and #2 cylinder, or for all cylinder in accordance with vehicle speed, engine speed, throttle position
- Judgment of heavy fuel: Not allowed to make the judgment of heavy fuel

### 9. ECM OPERATION AT DTC SETTING

Memorize the freeze frame data. (For test mode \$02)

# Diagnostic Trouble Code (DTC) Detecting Criteria

## GENERAL DESCRIPTION

### BR:DTC P0512 STARTER REQUEST CIRCUIT

#### 1. OUTLINE OF DIAGNOSIS

Detect the open or short circuit of starter SW.

Judge ON NG when the starter SW signal remains to be on.

Judge OFF NG when the engine starts without starter experience.

#### 2. ENABLE CONDITION

Secondary Parameters	Enable Conditions
None	

#### 3. GENERAL DRIVING CYCLE

Always perform the diagnosis continuously.

#### 4. DIAGNOSTIC METHOD

##### • Abnormality Judgment

Judge NG when the continuous time of completing the malfunction criteria below becomes more than 3 minutes.

##### Judgment Value

Malfunction Criteria	Threshold Value
Engine speed	> 500 rpm
Starter SW	ON
Battery voltage	> 8 V

**Time Needed for Diagnosis:** 180 seconds

**Malfunction Indicator Light Illumination:** Illuminates when malfunction occurs in 2 continuous driving cycles.

##### • Normality Judgment

Judge ON OK and clear the NG when the malfunction criteria below are completed.

##### Judgment Value

Malfunction Criteria	Threshold Value
Starter SW	OFF
Battery voltage	> 8 V

#### 5. DTC CLEAR CONDITION

- When the OK idling cycle was completed 40 times in a row
- When "Clear Memory" was performed

#### 6. MALFUNCTION INDICATOR LIGHT CLEAR CONDITION

- When the OK driving cycle was completed 3 times in a row
- When "Clear Memory" was performed

#### 7. FAIL SAFE

None

#### 8. ECM OPERATION AT DTC SETTING

Memorize the freeze frame data. (For test mode \$02)

# Diagnostic Trouble Code (DTC) Detecting Criteria

GENERAL DESCRIPTION

## BS:DTC P0519 IDLE CONTROL SYSTEM MALFUNCTION (FAIL-SAFE)

### 1. OUTLINE OF DIAGNOSIS

Detect the malfunction that engine speed increases more than that in normal condition during idling.

### 2. COMPONENT DESCRIPTION

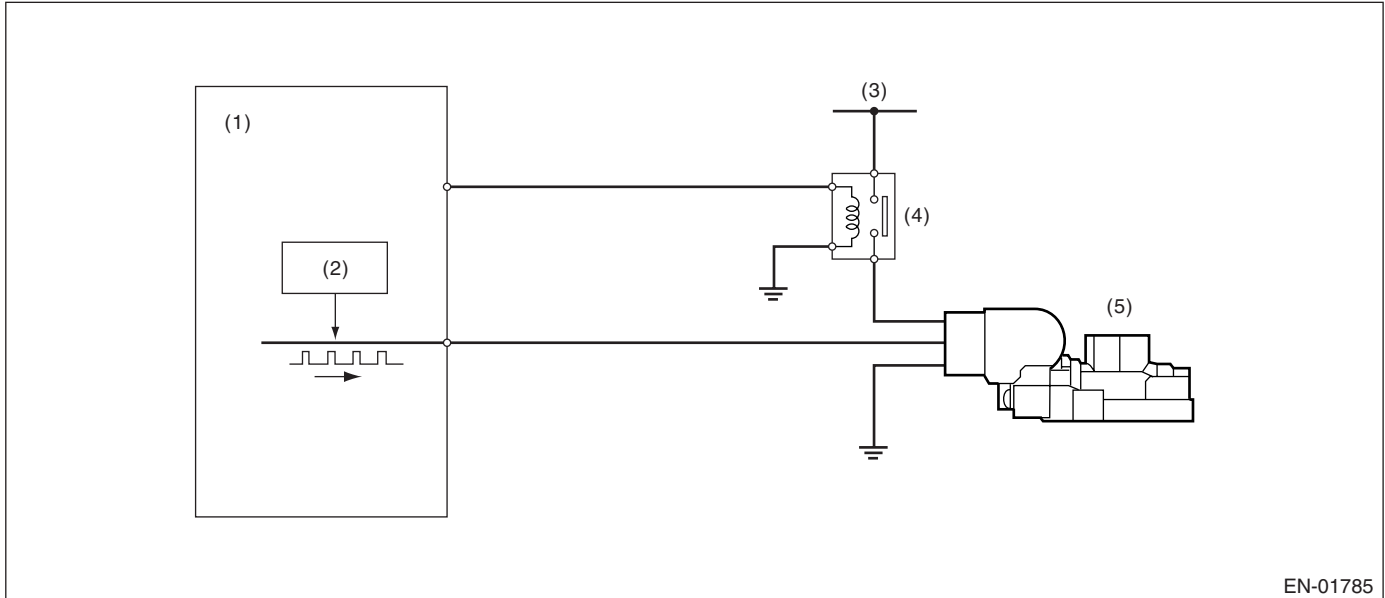

- (1) Engine control module (ECM)
- (2) Detecting circuit
- (3) Battery voltage
- (4) Main relay
- (5) Idle air control solenoid valve

### 3. ENABLE CONDITION

Secondary Parameters	Enable Conditions
Battery voltage	$\geq 10.9 \text{ V}$
Feedback in ISC	In operation
Vehicle speed	$< 4 \text{ km/h (2.49 MPH)}$
After engine starting	1 seconds or more

### 4. GENERAL DRIVING CYCLE

Always perform diagnosis at less than 4 km/h (2.49 MPH) of vehicle speed.

### 5. DIAGNOSTIC METHOD

#### • Abnormality Judgment 1

Judge NG when the continuous time until completing the all malfunction criteria below becomes more than the time needed for diagnosis (2 seconds).

#### Judgment Value

Malfunction Criteria	Threshold Value
Engine speed – target eng. speed	$\geq 1,000 \text{ rpm}$
Feedback value for ISC	$\leq 0$
Engine speed change every 180 degree engine rev.	$\geq -5 \text{ rpm}$

# Diagnostic Trouble Code (DTC) Detecting Criteria

## GENERAL DESCRIPTION

### • Abnormality Judgment 2

Judge NG when the continuous time until completing the all malfunction criteria below becomes more than the time needed for diagnosis (5 seconds).

#### Judgment Value

Malfunction Criteria	Threshold Value
Engine speed – target eng. speed	$\geq 1,000$ rpm
Feedback value for ISC	$\leq 0$

**Time Needed for Diagnosis:** 2 seconds or 5 seconds

**Malfunction Indicator Light Illumination:** Illuminates as soon as malfunction occurs.

### • Normality Judgment

Judge OK and clear NG when the continuous time until completing the malfunction criteria below becomes more than the time needed for diagnosis (5 seconds).

#### Judgment Value

Malfunction Criteria	Threshold Value
Engine speed – target eng. speed	$< 200$ rpm

## 6. DTC CLEAR CONDITION

- When the OK idling cycle was completed 40 times in a row
- When “Clear Memory” was performed

## 7. MALFUNCTION INDICATOR LIGHT CLEAR CONDITION

- When the OK driving cycle was completed 3 times in a row
- When “Clear Memory” was performed

## 8. FAIL SAFE

Fuel shut-off: Shut-off fuel for only #1 and #2 cylinder, or for all cylinder in accordance with vehicle speed, engine speed, throttle position

## 9. ECM OPERATION AT DTC SETTING

Memorize the freeze frame data. (For test mode \$02)

# Diagnostic Trouble Code (DTC) Detecting Criteria

GENERAL DESCRIPTION

## BT:DTC P0545 EXHAUST GAS TEMPERATURE SENSOR CIRCUIT LOW-BANK 1

### 1. OUTLINE OF DIAGNOSIS

Detect the open or short circuit of exhaust temperature sensor.  
Judge NG when out of the standard value.

### 2. COMPONENT DESCRIPTION

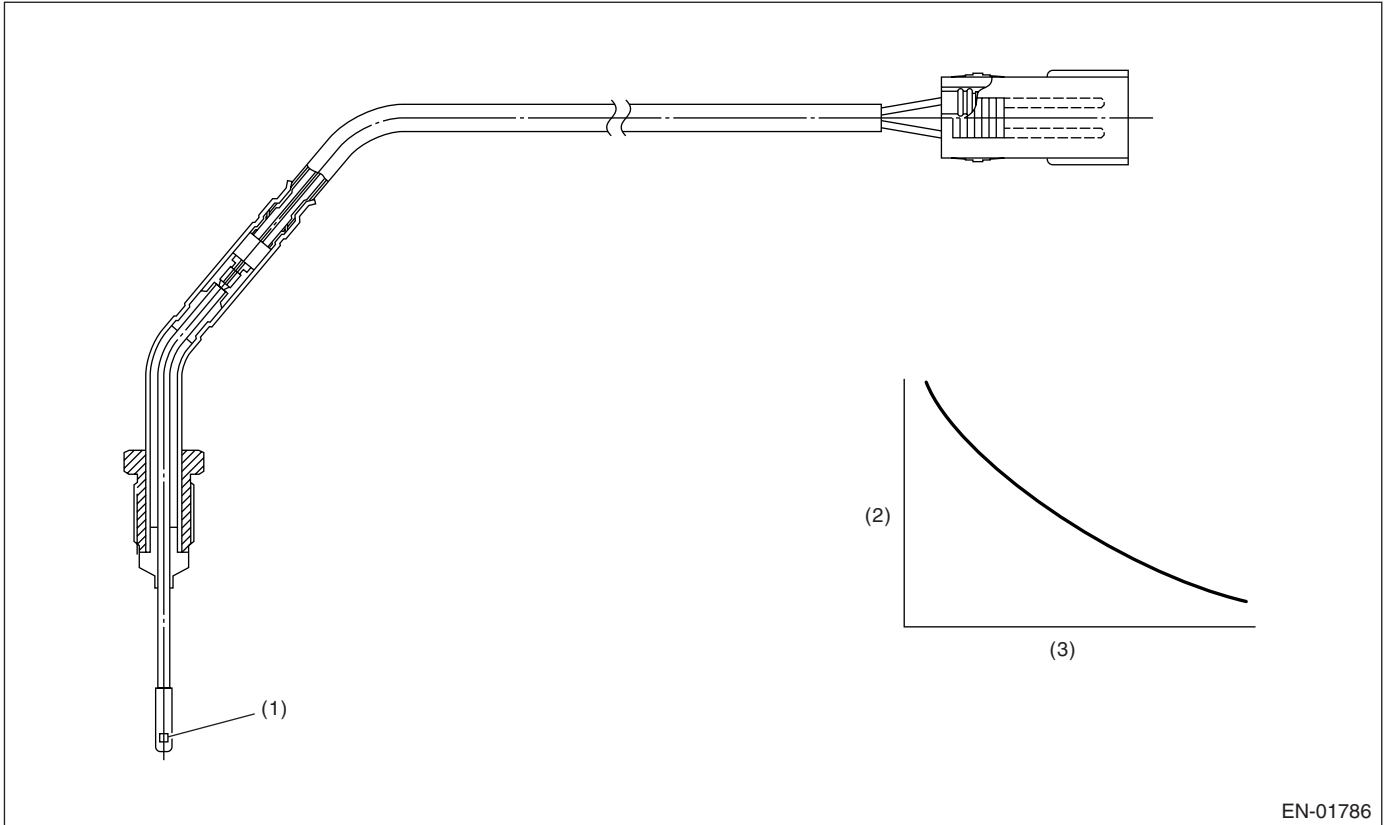

EN-01786

- (1) Thermistor
- (2) Resistance value (k $\Omega$ )
- (3) Exhaust temperature  $^{\circ}\text{C}$  ( $^{\circ}\text{F}$ )

### 3. ENABLE CONDITION

Secondary Parameters	Enable Conditions
None	

### 4. GENERAL DRIVING CYCLE

Always perform the diagnosis continuously.

### 5. DIAGNOSTIC METHOD

#### • Abnormality Judgment

Judge NG when the continuous time of completing the malfunction criteria below becomes more than the time needed for diagnosis (5 seconds).

#### Judgment Value

Malfunction Criteria	Threshold Value
Sensor output voltage	< 0.15 V
Amount of intake air	< 100 g/s

# Diagnostic Trouble Code (DTC) Detecting Criteria

## GENERAL DESCRIPTION

---

**Time Needed for Diagnosis:** 5 seconds

**Malfunction Indicator Light Illumination:** Illuminates as soon as the malfunction occurs.

• **Normality Judgment**

Judge OK and clear the NG when the malfunction criteria below are completed.

**Judgment Value**

Malfunction Criteria	Threshold Value
Sensor output voltage	$\geq 0.15$ V

### 6. DTC CLEAR CONDITION

- When the OK idling cycle was completed 40 times in a row
- When "Clear Memory" was performed

### 7. MALFUNCTION INDICATOR LIGHT CLEAR CONDITION

- When the OK driving cycle was completed 3 times in a row
- When "Clear Memory" was performed

### 8. FAIL SAFE

None

### 9. ECM OPERATION AT DTC SETTING

Memorize the freeze frame data. (For test mode \$02)

# Diagnostic Trouble Code (DTC) Detecting Criteria

GENERAL DESCRIPTION

## BU:DTC P0546 EXHAUST GAS TEMPERATURE SENSOR CIRCUIT HIGH-BANK 1

### 1. OUTLINE OF DIAGNOSIS

Detect the open or short circuit of exhaust temperature sensor.  
Judge NG when out of the standard value.

### 2. COMPONENT DESCRIPTION

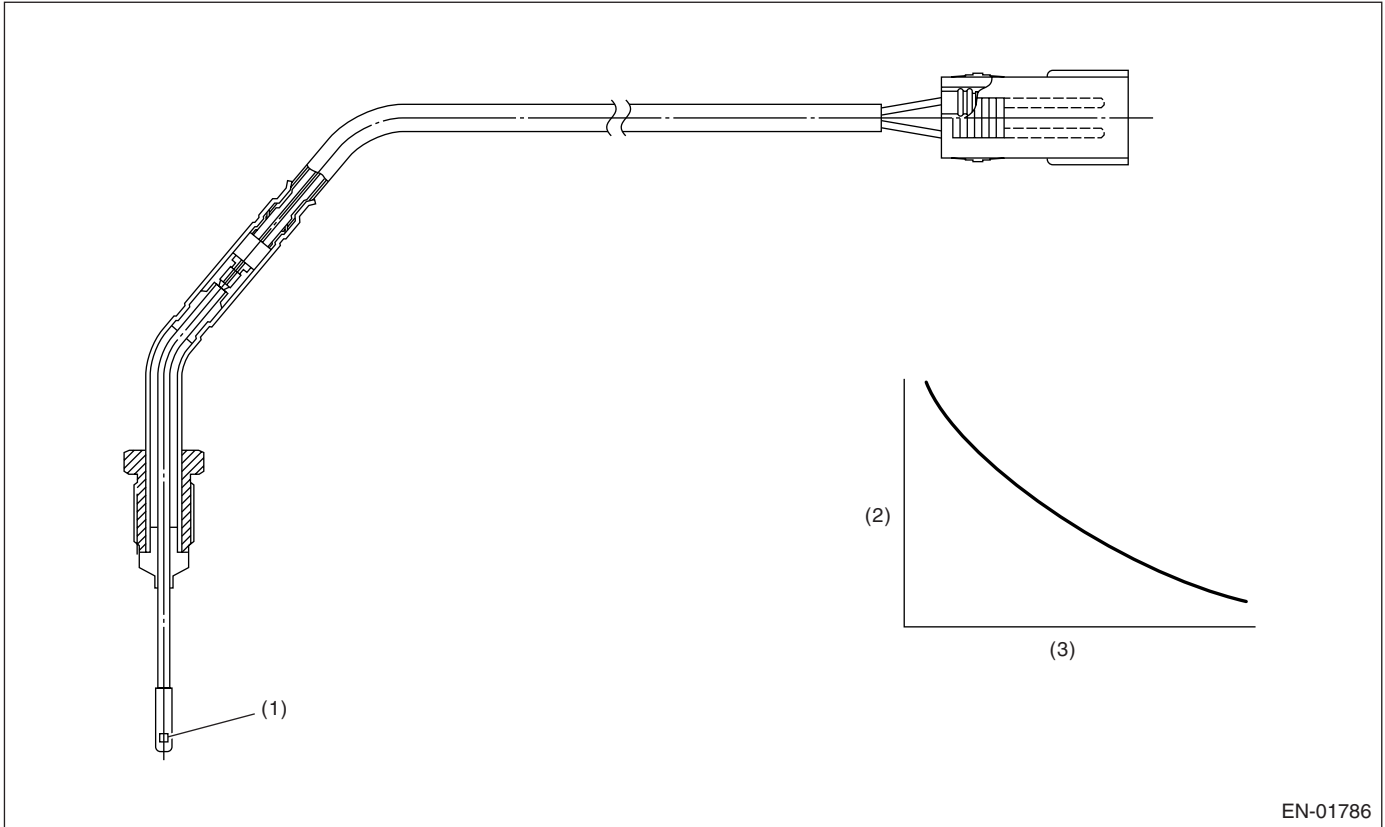

- (1) Thermistor
- (2) Resistance value (k $\Omega$ )
- (3) Exhaust temperature °C (°F)

### 3. ENABLE CONDITION

Secondary Parameters	Enable Conditions
None	

### 4. GENERAL DRIVING CYCLE

Always perform the diagnosis continuously.



# Diagnostic Trouble Code (DTC) Detecting Criteria

## GENERAL DESCRIPTION

### 5. DIAGNOSTIC METHOD

#### • Abnormality Judgment

Judge NG when the cumulative time of completing the malfunction criteria below becomes more than the time needed for diagnosis (30 seconds).

#### Judgment Value

Malfunction Criteria	Threshold Value
After engine starting	240 seconds or more
Engine coolant temperature	≥ 75°C (167°F)
Vehicle speed	≥ 65 km/h (40.4 MPH)
Engine speed	≥ 1,800 rpm
Engine load (gn)	≥ 0.6 g/rev
Fuel cut event	Not operating
After the recovery from fuel cut event	30 seconds or more
Sensor output voltage	≥ 4.72 V

**Time Needed for Diagnosis:** 30 seconds

**Malfunction Indicator Light Illumination:** Illuminates as soon as the malfunction occurs.

#### • Normality Judgment

Judge OK and clear the NG when the malfunction criteria below are completed.

#### Judgment Value

Malfunction Criteria	Threshold Value
Sensor output voltage	< 4.72 V

### 6. DTC CLEAR CONDITION

- When the OK idling cycle was completed 40 times in a row
- When "Clear Memory" was performed

### 7. MALFUNCTION INDICATOR LIGHT CLEAR CONDITION

- When the OK driving cycle was completed 3 times in a row
- When "Clear Memory" was performed

### 8. FAIL SAFE

None

### 9. ECM OPERATION AT DTC SETTING

Memorize the freeze frame data. (For test mode \$02)

# Diagnostic Trouble Code (DTC) Detecting Criteria

GENERAL DESCRIPTION

## BV:DTC P0565 CRUISE CONTROL ON SIGNAL

### 1. OUTLINE OF DIAGNOSIS

Judge NG when the cruise control set signal is continued to be ON for a certain period of time at the vehicle speed less than 20 km/h (12 MPH).

### 2. ENABLE CONDITION

Secondary Parameters	Enable Conditions
Vehicle speed	≤ 20 km/h (12.4 MPH)

### 3. GENERAL DRIVING CYCLE

Always perform diagnosis at vehicle speed 20 km/h (12.4 MPH) or less.

### 4. DIAGNOSTIC METHOD

#### Judgment Value

Malfunction Criteria	Threshold Value
Canceling signal	No signal

**Time Needed for Diagnosis:** 10 seconds

**Malfunction Indicator Light Illumination:** Illuminates when malfunction occurs in 2 continuous driving cycles.

### 5. DTC CLEAR CONDITION

- When the OK idling cycle was completed 40 times in a row
- When "Clear Memory" was performed

### 6. MALFUNCTION INDICATOR LIGHT CLEAR CONDITION

- When the OK driving cycle was completed 3 times in a row
- When "Clear Memory" was performed

### 7. FAIL SAFE

None

### 8. ECM OPERATION AT DTC SETTING

Memorize the freeze frame data. (For test mode \$02)

# Diagnostic Trouble Code (DTC) Detecting Criteria

## GENERAL DESCRIPTION

### **BW:DTC P0604 INTERNAL CONTROL MODULE RANDOM ACCESS MEMORY (RAM) ERROR**

#### **1. OUTLINE OF DIAGNOSIS**

Detect the function abnormality of the micro-computer (RAM).

Normally, zero-clear all the RAM area in the initial routine. And judge NG when the total of all the RAM after the clear is not \$0000.

#### **2. ENABLE CONDITION**

Secondary Parameters	Enable Conditions
None	

Perform the diagnosis in the initial routine.

#### **3. GENERAL DRIVING CYCLE**

Perform the diagnosis immediately after IG key SW is turned ON.

#### **4. DIAGNOSTIC METHOD**

Judge NG when the malfunction criteria below are completed. Judge OK and clear NG when the malfunction criteria below are not completed.

##### **Judgment Value**

Malfunction Criteria	Threshold Value
Total of all the RAM after the zero-clear the all the normal RAM area.	Not to 0

**Time Needed for Diagnosis:** Undecided

**Malfunction Indicator Light Illumination:** Illuminates as soon as malfunction occurs.

#### **5. DTC CLEAR CONDITION**

- When the OK idling cycle was completed 40 times in a row
- When "Clear Memory" was performed

#### **6. MALFUNCTION INDICATOR LIGHT CLEAR CONDITION**

- When the OK driving cycle was completed 3 times in a row
- When "Clear Memory" was performed

#### **7. FAIL SAFE**

None

#### **8. ECM OPERATION AT DTC SETTING**

Memorize the freeze frame data. (For test mode \$02)

# Diagnostic Trouble Code (DTC) Detecting Criteria

GENERAL DESCRIPTION

## BX:DTC P0691 COOLING FAN 1 CONTROL CIRCUIT LOW

### 1. OUTLINE OF DIAGNOSIS

Detect the open or short circuit of the radiator fan circuit.

Judge NG when the ECM output level differs from the actual terminal level.

### 2. ENABLE CONDITION

Secondary Parameters	Enable Conditions
None	

### 3. GENERAL DRIVING CYCLE

Always perform the diagnosis continuously.

### 4. DIAGNOSTIC METHOD

#### • Abnormality Judgment

Judge NG when the cumulative time of completing the malfunction criteria below becomes more than 2.5 seconds.

#### Judgment Value

Malfunction Criteria	Threshold Value
After starting the engine	1 seconds or more
Engine speed	≥ 500 rpm
Ignition switch	ON
Battery voltage	≥ 10.9 V
Terminal voltage level when ECM transmits OFF signal	Low level

**Time Needed for Diagnosis:** 2.5 seconds

**Malfunction Indicator Light Illumination:** Illuminates when malfunction occurs in 2 continuous driving cycles.

#### • Normality Judgment

Judge OK and clear NG when the malfunction criteria below are completed.

#### Judgment Value

Malfunction Criteria	Threshold Value
After starting the engine	1 seconds or more
Engine speed	≥ 500 rpm
Ignition switch	ON
Battery voltage	≥ 10.9 V
Terminal voltage level when ECM transmits OFF signal	High level

### 5. DTC CLEAR CONDITION

- When the OK idling cycle was completed 40 times in a row
- When "Clear Memory" was performed

### 6. MALFUNCTION INDICATOR LIGHT CLEAR CONDITION

- When the OK driving cycle was completed 3 times in a row
- When "Clear Memory" was performed

### 7. FAIL SAFE

None

### 8. ECM OPERATION AT DTC SETTING

Memorize the freeze frame data. (For test mode \$02)

# Diagnostic Trouble Code (DTC) Detecting Criteria

## GENERAL DESCRIPTION

### BY:DTC P0692 COOLING FAN 1 CONTROL CIRCUIT HIGH

#### 1. OUTLINE OF DIAGNOSIS

Detect the open or short circuit of the radiator fan circuit.

Judge NG when the ECM output level differs from the actual terminal level.

#### 2. ENABLE CONDITION

Secondary Parameters	Enable Conditions
None	

#### 3. GENERAL DRIVING CYCLE

Always perform the diagnosis continuously.

#### 4. DIAGNOSTIC METHOD

##### • Abnormality Judgment

Judge NG when the cumulative time of completing the malfunction criteria below becomes more than 2.5 seconds.

##### Judgment Value

Malfunction Criteria	Threshold Value
After starting the engine	1 seconds or more
Engine speed	≥ 500 rpm
Ignition switch	ON
Battery voltage	≥ 10.9 V
Terminal voltage level when ECM transmits ON signal	High level

**Time Needed for Diagnosis:** 2.5 seconds

**Malfunction Indicator Light Illumination:** Illuminates when malfunction occurs in 2 continuous driving cycles.

##### • Normality Judgment

Judge OK and clear NG when the malfunction criteria below are completed.

##### Judgment Value

Malfunction Criteria	Threshold Value
After starting the engine	1 seconds or more
Engine speed	≥ 500 rpm
Ignition switch	ON
Battery voltage	≥ 10.9 V
Terminal voltage level when ECM transmits ON signal	Low level

#### 5. DTC CLEAR CONDITION

- When the OK idling cycle was completed 40 times in a row
- When "Clear Memory" was performed

#### 6. MALFUNCTION INDICATOR LIGHT CLEAR CONDITION

- When the OK driving cycle was completed 3 times in a row
- When "Clear Memory" was performed

#### 7. FAIL SAFE

None

#### 8. ECM OPERATION AT DTC SETTING

Memorize the freeze frame data. (For test mode \$02)

# Diagnostic Trouble Code (DTC) Detecting Criteria

GENERAL DESCRIPTION

## BZ:DTC P0703 TORQUE CONVERTER/BRAKE SWITCH “B” CIRCUIT

### 1. OUTLINE OF DIAGNOSIS

Judge NG when the AT brake switch circuit becomes battery short, ground short or open circuit.

### 2. ENABLE CONDITION

Secondary Parameters	Enable Conditions
Vehicle speed change	30 to 0 km/h (18.6 to 0 MPH) 0 to 30 km/h (0 to 18.6 MPH)

### 3. GENERAL DRIVING CYCLE

Always perform the diagnosis continuously.

### 4. DIAGNOSTIC METHOD

#### Judgment Value

Malfunction Criteria	Threshold Value
ON signal	No signal
OFF signal	No signal

**Time Needed for Diagnosis:** 10 times

**Malfunction Indicator Light Illumination:** Illuminates when malfunction occurs in 2 continuous driving cycles.

### 5. DTC CLEAR CONDITION

- When the OK idling cycle was completed 40 times in a row
- When “Clear Memory” was performed

### 6. MALFUNCTION INDICATOR LIGHT CLEAR CONDITION

- When the OK driving cycle was completed 3 times in a row
- When “Clear Memory” was performed

### 7. FAIL SAFE

None

### 8. ECM OPERATION AT DTC SETTING

Memorize the freeze frame data. (For test mode \$02)

# Diagnostic Trouble Code (DTC) Detecting Criteria

## GENERAL DESCRIPTION

### CA:DTC P0705 TRANSMISSION RANGE SENSOR CIRCUIT (PRNDL INPUT)

#### 1. OUTLINE OF DIAGNOSIS

Judge NG when the “D” range switch becomes ground short or open circuit.

#### 2. COMPONENT DESCRIPTION

Inhibitor switch ensures the safety at engine start. This switch is installed to the right side of transmission case, and operated by selector lever. When the selector lever is in the “P” or “N” range, the engine will start because the electric circuit in inhibitor switch is closed and the starter circuit is connected. When the selector lever is in the “R”, “D”, “3”, “2” or “1” range, the electric circuit in inhibitor switch is open; therefore, the engine cannot be cranked. In the “R” range, the back-up light will illuminate because the back-up light circuit in the switch is connected. In addition to the functions above, the inhibitor switch has the circuit which detects the selected range position at the present and transmits the range signal to the TCM.

#### 3. ENABLE CONDITION

Secondary Parameters	Enable Conditions
Shift	“N” to “3”
Vehicle speed	≥ 60 km/h (37 MPH)
Engine speed	> 500 rpm
Battery voltage	> 10.9 V

#### 4. GENERAL DRIVING CYCLE

Always perform the diagnosis continuously.

#### 5. DIAGNOSTIC METHOD

##### Judgment Value

Malfunction Criteria	Threshold Value
“D” signal continuously	Not detected
Simultaneous signal	≥ 2

##### Time Needed for Diagnosis:

- 63.75 seconds
- 10 seconds

**Malfunction Indicator Light Illumination:** Illuminates when malfunction occurs in 2 continuous driving cycles.

#### 6. DTC CLEAR CONDITION

- When the OK idling cycle was completed 40 times in a row
- When “Clear Memory” was performed

#### 7. MALFUNCTION INDICATOR LIGHT CLEAR CONDITION

- When the OK driving cycle was completed 3 times in a row
- When “Clear Memory” was performed

#### 8. FAIL SAFE

None

#### 9. ECM OPERATION AT DTC SETTING

Memorize the freeze frame data. (For test mode \$02)

# Diagnostic Trouble Code (DTC) Detecting Criteria

GENERAL DESCRIPTION

## CB:DTC P0710 TRANSMISSION FLUID TEMPERATURE SENSOR CIRCUIT

### 1. OUTLINE OF DIAGNOSIS

- Judge NG when ATF temperature sensor becomes open circuit, battery short or ground short.
- Judge NG when ATF temperature sensor is faulty.

### 2. COMPONENT DESCRIPTION

ATF temperature sensor is installed to the hydraulic control valve body of transmission as a unit with transmission harness. This sensor detects ATF temperature and outputs it as electric resistance signal.

### 3. ENABLE CONDITION

Secondary Parameters	Enable Conditions
None	

### 4. GENERAL DRIVING CYCLE

Always perform the diagnosis continuously.

### 5. DIAGNOSTIC METHOD

#### Judgment Value

Malfunction Criteria	Threshold Value
Output voltage	$\leq 0.1$ V
Output at $\geq 80$ km/h (50 MPH) after 5 minutes from reaching more than 4.8 V	$\geq 4.7$ V

**Time Needed for Diagnosis:** 63.75 seconds

**Malfunction Indicator Light Illumination:** Illuminates when malfunction occurs in 2 continuous driving cycles.

### 6. DTC CLEAR CONDITION

- When the OK idling cycle was completed 40 times in a row
- When "Clear Memory" was performed

### 7. MALFUNCTION INDICATOR LIGHT CLEAR CONDITION

- When the OK driving cycle was completed 3 times in a row
- When "Clear Memory" was performed

### 8. FAIL SAFE

Control ATF temperature at a constant temperature 80°C (176°F)

### 9. ECM OPERATION AT DTC SETTING

Memorize the freeze frame data. (For test mode \$02)



# Diagnostic Trouble Code (DTC) Detecting Criteria

## GENERAL DESCRIPTION

### CC:DTC P0716 INPUT/TURBINE SPEED SENSOR CIRCUIT RANGE/PERFORMANCE

#### 1. OUTLINE OF DIAGNOSIS

Judge NG when the turbine speed signal is not transmitted for some reasons.

#### 2. COMPONENT DESCRIPTION

Torque converter turbine speed sensor (output shaft speed sensor) is installed to the outside of transmission case. This sensor detects the turbine speed of torque converter by the peripheral speed of high clutch drum connected to input shaft. And then it transmits the sine wave signal (32 pulses per rev.) to TCM. TCM calculates the ratio of the input shaft speed to vehicle speed, and then makes a judgment whether to shift or not.

#### 3. ENABLE CONDITION

Secondary Parameters	Enable Conditions
Engine speed	≥ 1,500 rpm
Vehicle speed	≥ 40 km/h (25 MPH)
Range switch	"D", "3", "2" or "1"

#### 4. GENERAL DRIVING CYCLE

Always perform the diagnosis continuously.

#### 5. DIAGNOSTIC METHOD

Perform the diagnosis when the conditions below were continued for 2 seconds.

- (1) Except "P", "N", "R" ranges and inhibitor switch is normal.
- (2) Engine speed is more than 3,000 rpm.
- (3) Vehicle speed is 30 km/h (19 MPH) and vehicle speed sensor is normal.
- (4) Turbine speed is more than 600 rpm.

#### Judgment Value

Malfunction Criteria	Threshold Value
Output from turbine shaft speed	< 600 rpm

**Time Needed for Diagnosis:** 2 seconds

**Malfunction Indicator Light Illumination:** Illuminates when malfunction occurs in 2 continuous driving cycles.

#### 6. DTC CLEAR CONDITION

- When the OK idling cycle was completed 40 times in a row
- When "Clear Memory" was performed

#### 7. MALFUNCTION INDICATOR LIGHT CLEAR CONDITION

- When the OK driving cycle was completed 3 times in a row
- When "Clear Memory" was performed

#### 8. FAIL SAFE

None

#### 9. ECM OPERATION AT DTC SETTING

Memorize the freeze frame data. (For test mode \$02)

# Diagnostic Trouble Code (DTC) Detecting Criteria

GENERAL DESCRIPTION

## CD:DTC P0720 OUTPUT SPEED SENSOR CIRCUIT

### 1. OUTLINE OF DIAGNOSIS

Judge NG when an abnormal large signal is input to the front vehicle speed sensor, or no signal is input to the rear vehicle speed sensor.

### 2. COMPONENT DESCRIPTION

This vehicle speed sensor (output shaft speed sensor) is installed to the outside of transmission case. This sensor detects the front wheel speed, and transmits the sine wave signal (32 pulses per rev.) to TCM. TCM converts the signal to pulse signal, and transmits to both of the ECM and the combination meter.

### 3. ENABLE CONDITION

Secondary Parameters	Enable Conditions
Vehicle speed	≥ 20 km/h (12 MPH)

### 4. GENERAL DRIVING CYCLE

Always perform the diagnosis with more than 20 km/h (12 MPH) vehicle speed.

### 5. DIAGNOSTIC METHOD

#### Judgment Value

Malfunction Criteria	Threshold Value
Vehicle speed sensor	
Front	≥ 255 km/h (158 MPH)
Rear	= 0 km/h (0 MPH)
Front vehicle speed sensor(During vehicle running at 20 km/h)	= 0 km/h (0 MPH)

**Time Needed for Diagnosis:** 63.75 seconds

**Malfunction Indicator Light Illumination:** Illuminates when malfunction occurs in 2 continuous driving cycles.

### 6. DTC CLEAR CONDITION

- When the OK idling cycle was completed 40 times in a row
- When "Clear Memory" was performed

### 7. MALFUNCTION INDICATOR LIGHT CLEAR CONDITION

- When the OK driving cycle was completed 3 times in a row
- When "Clear Memory" was performed

### 8. FAIL SAFE

- Use the normal vehicle speed sensor signal when either of them is normal.
- Use the vehicle speed calculated from the current gear position and turbine speed when both front and rear wheels are troubled.

### 9. ECM OPERATION AT DTC SETTING

Memorize the freeze frame data. (For test mode \$02)

# Diagnostic Trouble Code (DTC) Detecting Criteria

## GENERAL DESCRIPTION

### CE:DTC P0726 ENGINE SPEED INPUT CIRCUIT RANGE/PERFORMANCE

#### 1. OUTLINE OF DIAGNOSIS

Judge NG when the engine speed is not input in the status of running the engine.

#### 2. COMPONENT DESCRIPTION

Engine speed sensor is installed to the outside of engine body and crank part. This sensor detects the crank speed, and transmits the sine wave signal (2 pulses per rev.) to TCM.

#### 3. ENABLE CONDITION

Secondary Parameters	Enable Conditions
Output from mass air flow sensor	$\geq 1.12 - 1.52$ V

#### 4. GENERAL DRIVING CYCLE

Always perform the diagnosis continuously.

#### 5. DIAGNOSTIC METHOD

##### Judgment Value

Malfunction Criteria	Threshold Value
Engine speed	$\leq 400$ rpm

**Time Needed for Diagnosis:** 63.75 seconds

**Malfunction Indicator Light Illumination:** Illuminates when malfunction occurs in 2 continuous driving cycles.

#### 6. DTC CLEAR CONDITION

- When the OK idling cycle was completed 40 times in a row
- When "Clear Memory" was performed

#### 7. MALFUNCTION INDICATOR LIGHT CLEAR CONDITION

- When the OK driving cycle was completed 3 times in a row
- When "Clear Memory" was performed

#### 8. FAIL SAFE

None

#### 9. ECM OPERATION AT DTC SETTING

Memorize the freeze frame data. (For test mode \$02)

# Diagnostic Trouble Code (DTC) Detecting Criteria

GENERAL DESCRIPTION

## CF:DTC P0731 GEAR 1 INCORRECT RATIO

### 1. OUTLINE OF DIAGNOSIS

Judge NG when the expected present gear is different from the actual gear.

### 2. ENABLE CONDITION

Secondary Parameters	Enable Conditions
Throttle angle	$\geq 15^\circ$
Vehicle speed	$\geq 10$ km/h (6 MPH)
Range switch	"D", "3", "2" or "1"
Upshift or downshift events	Not in operation

### 3. GENERAL DRIVING CYCLE

Always perform the diagnosis with less than 10 km/h (6 MPH) vehicle speed.

### 4. DIAGNOSTIC METHOD

Perform the diagnosis when the conditions below are not completed for more than 40 milliseconds on normal control.

- (1) Vehicle speed is more than 10 km/h (6 MPH).
- (2) Throttle sensor is more than a certain angle.
- (3) Shifted to "D", "3", "2" or "1" range, and range signal is normal.
- (4) More than 1 second passed after shift change finished.

#### Judgment Value

Malfunction Criteria	Threshold Value
GR/(1st gear ratio) where, GR = (vehicle speed sensor 1 output)/ (turbine shaft speed sensor output)	$> 110\%$ or $< 90\%$

**Time Needed for Diagnosis:** 3 seconds

**Malfunction Indicator Light Illumination:** Illuminates when malfunction occurs in 2 continuous driving cycles.

### 5. DTC CLEAR CONDITION

- When the OK idling cycle was completed 40 times in a row
- When "Clear Memory" was performed

### 6. MALFUNCTION INDICATOR LIGHT CLEAR CONDITION

- When the OK driving cycle was completed 3 times in a row
- When "Clear Memory" was performed

### 7. FAIL SAFE

None

### 8. ECM OPERATION AT DTC SETTING

Memorize the freeze frame data. (For test mode \$02)

# Diagnostic Trouble Code (DTC) Detecting Criteria

## GENERAL DESCRIPTION

### CG:DTC P0732 GEAR 2 INCORRECT RATIO

#### 1. OUTLINE OF DIAGNOSIS

Judge NG when the expected present gear is different from the actual gear.

#### 2. ENABLE CONDITION

Secondary Parameters	Enable Conditions
Throttle angle	$\geq 15^\circ$
Vehicle speed	$\geq 10$ km/h (6 MPH)
Range switch	"D", "3", "2" or "1"
Upshift or downshift events	Not in operation

#### 3. GENERAL DRIVING CYCLE

Always perform the diagnosis with less than 10 km/h (6 MPH) vehicle speeds.

#### 4. DIAGNOSTIC METHOD

Perform the diagnosis when the conditions below are not completed for more than 40 milliseconds on normal control.

- (1) Vehicle speed is more than 10 km/h (6 MPH).
- (2) Throttle sensor is more than a certain angle.
- (3) Shifted to "D", "3", "2" or "1" range, and range signal is normal.
- (4) More than 1 second passed after shift change finished.

#### Judgment Value

Malfunction Criteria	Threshold Value
GR/(2nd gear ratio) Where, GR = (Vehicle speed sensor 1 output)/ (Turbine shaft speed sensor output)	$> 110\%$ or $< 90\%$

**Time Needed for Diagnosis:** 3 seconds

**Malfunction Indicator Light Illumination:** Illuminates when malfunction occurs in 2 continuous driving cycles.

#### 5. DTC CLEAR CONDITION

- When the OK idling cycle was completed 40 times in a row
- When "Clear Memory" was performed

#### 6. MALFUNCTION INDICATOR LIGHT CLEAR CONDITION

- When the OK driving cycle was completed 3 times in a row
- When "Clear Memory" was performed

#### 7. FAIL SAFE

None

#### 8. ECM OPERATION AT DTC SETTING

Memorize the freeze frame data. (For test mode \$02)

# Diagnostic Trouble Code (DTC) Detecting Criteria

GENERAL DESCRIPTION

## CH:DTC P0733 GEAR 3 INCORRECT RATIO

### 1. OUTLINE OF DIAGNOSIS

Judge NG when the expected present gear is different from the actual gear.

### 2. ENABLE CONDITION

Secondary Parameters	Enable Conditions
Throttle angle	≥ 15°
Vehicle speed	≥ 10 km/h (6 MPH)
Range switch	"D", "3", "2" or "1"
Upshift or downshift events	Not in operation

### 3. GENERAL DRIVING CYCLE

Always perform the diagnosis with less than 10 km/h (6 MPH) vehicle speeds.

### 4. DIAGNOSTIC METHOD

Perform the diagnosis when the conditions below are not completed for more than 40 milliseconds on normal control.

- (1) Vehicle speed is more than 10 km/h (6 MPH).
- (2) Throttle sensor is more than a certain angle.
- (3) Shifted to "D", "3", "2" or "1" range, and range signal is normal.
- (4) More than 1 second passed after shift change finished.

#### Judgment Value

Malfunction Criteria	Threshold Value
GR/(3rd gear ratio) Where, GR = (Vehicle speed sensor 1 output)/ (Turbine shaft speed sensor output)	> 110% or < 90%

**Time Needed for Diagnosis:** 3 seconds

**Malfunction Indicator Light Illumination:** Illuminates when malfunction occurs in 2 continuous driving cycles.

### 5. DTC CLEAR CONDITION

- When the OK idling cycle was completed 40 times in a row
- When "Clear Memory" was performed

### 6. MALFUNCTION INDICATOR LIGHT CLEAR CONDITION

- When the OK driving cycle was completed 3 times in a row
- When "Clear Memory" was performed

### 7. FAIL SAFE

None

### 8. ECM OPERATION AT DTC SETTING

Memorize the freeze frame data. (For test mode \$02)

# Diagnostic Trouble Code (DTC) Detecting Criteria

## GENERAL DESCRIPTION

### CI: DTC P0734 GEAR 4 INCORRECT RATIO

#### 1. OUTLINE OF DIAGNOSIS

Judge NG when the expected present gear is different from the actual gear.

#### 2. ENABLE CONDITION

Secondary Parameters	Enable Conditions
Throttle angle	$\geq 15^\circ$
Vehicle speed	$\geq 10$ km/h (6 MPH)
Range switch	"D", "3", "2" or "1"
Upshift or downshift events	Not in operation

#### 3. GENERAL DRIVING CYCLE

Always perform the diagnosis with less than 10 km/h (6 MPH) vehicle speeds.

#### 4. DIAGNOSTIC METHOD

Perform the diagnosis when the conditions below are not completed for more than 40 milliseconds on normal control.

- (1) Vehicle speed is more than 10 km/h (6 MPH).
- (2) Throttle sensor is more than a certain angle.
- (3) Shifted to "D", "3", "2" or "1" range, and range signal is normal.
- (4) More than 1 second passed after shift change finished.

#### Judgment Value

Malfunction Criteria	Threshold Value
GR/(4th gear ratio) Where, GR = (Vehicle speed sensor 1 output)/ (Turbine shaft speed sensor output)	$> 110\%$ or $< 90\%$

**Time Needed for Diagnosis:** 3 seconds

**Malfunction Indicator Light Illumination:** Illuminates when malfunction occurs in 2 continuous driving cycles.

#### 5. DTC CLEAR CONDITION

- When the OK idling cycle was completed 40 times in a row
- When "Clear Memory" was performed

#### 6. MALFUNCTION INDICATOR LIGHT CLEAR CONDITION

- When the OK driving cycle was completed 3 times in a row
- When "Clear Memory" was performed

#### 7. FAIL SAFE

None

#### 8. ECM OPERATION AT DTC SETTING

Memorize the freeze frame data. (For test mode \$02)

# Diagnostic Trouble Code (DTC) Detecting Criteria

GENERAL DESCRIPTION

## CJ:DTC P0741 TORQUE CONVERTER CLUTCH CIRCUIT PERFORMANCE OR STUCK OFF

### 1. OUTLINE OF DIAGNOSIS

Judge NG when the engine speed is different from the turbine speed for some reasons at AT lock-up.

### 2. ENABLE CONDITION

Secondary Parameters	Enable Conditions
In 4th gear position, duty ratio for duty solenoid valve	$\geq 90\%$

### 3. GENERAL DRIVING CYCLE

Always perform the diagnosis continuously.

### 4. DIAGNOSTIC METHOD

#### Judgment Value

Malfunction Criteria	Threshold Value
Engine speed $\geq$ (output shaft speed $\times$ 4th gear ratio $\times 9/8$ )	

**Time Needed for Diagnosis:** 10.2 seconds

**Malfunction Indicator Light Illumination:** Illuminates when malfunction occurs in 2 continuous driving cycles.

### 5. DTC CLEAR CONDITION

- When the OK idling cycle was completed 40 times in a row
- When "Clear Memory" was performed

### 6. MALFUNCTION INDICATOR LIGHT CLEAR CONDITION

- When the OK driving cycle was completed 3 times in a row
- When "Clear Memory" was performed

### 7. FAIL SAFE

Not allowed to lock up.

### 8. ECM OPERATION AT DTC SETTING

Memorize the freeze frame data. (For test mode \$02)



# Diagnostic Trouble Code (DTC) Detecting Criteria

## GENERAL DESCRIPTION

### CK:DTC P0743 TORQUE CONVERTER CLUTCH CIRCUIT ELECTRICAL

#### 1. OUTLINE OF DIAGNOSIS

Judge NG when the lock-up duty solenoid becomes battery short, ground short or open circuit.

#### 2. COMPONENT DESCRIPTION

Lock-up duty solenoid is installed to the transmission hydraulic control valve body. The duty ratio is controlled by the signal from TCM. This allows the lock-up clutch to be connected or released smoothly by controlling the lock-up control valve.

#### 3. ENABLE CONDITION

Secondary Parameters	Enable Conditions
None	

#### 4. GENERAL DRIVING CYCLE

Always perform the diagnosis continuously.

#### 5. DIAGNOSTIC METHOD

##### Judgment Value

Malfunction Criteria	Threshold Value
Vc at "ON" signal from ECM	Low level
Vc at "OFF" signal from ECM	High level

**Time Needed for Diagnosis:** 0.14 seconds

**Malfunction Indicator Light Illumination:** Illuminates when malfunction occurs in 2 continuous driving cycles.

#### 6. DTC CLEAR CONDITION

- When the OK idling cycle was completed 40 times in a row
- When "Clear Memory" was performed

#### 7. MALFUNCTION INDICATOR LIGHT CLEAR CONDITION

- When the OK driving cycle was completed 3 times in a row
- When "Clear Memory" was performed

#### 8. FAIL SAFE

None

#### 9. ECM OPERATION AT DTC SETTING

Memorize the freeze frame data. (For test mode \$02)

# Diagnostic Trouble Code (DTC) Detecting Criteria

GENERAL DESCRIPTION

## CL:DTC P0748 PRESSURE CONTROL SOLENOID "A" ELECTRICAL

### 1. OUTLINE OF DIAGNOSIS

Judge NG when the line pressure duty solenoid becomes battery short, ground short or open circuit.

### 2. COMPONENT DESCRIPTION

Line pressure duty solenoid is installed to the transmission hydraulic control valve body. The duty ratio is controlled by the signal from TCM. This allows controlling the pressure modifier valve and accumulator control valve A, and allows the line pressure to be adjusted to the pressure appropriate for driving condition.

### 3. ENABLE CONDITION

Secondary Parameters	Enable Conditions
None	

### 4. GENERAL DRIVING CYCLE

Always perform the diagnosis continuously.

### 5. DIAGNOSTIC METHOD

#### Judgment Value

Malfunction Criteria	Threshold Value
Vc at "ON" signal from ECM	Low level
Vc at "OFF" signal from ECM	High level

**Time Needed for Diagnosis:** 0.14 seconds

**Malfunction Indicator Light Illumination:** Illuminates when malfunction occurs in 2 continuous driving cycles.

### 6. DTC CLEAR CONDITION

- When the OK idling cycle was completed 40 times in a row
- When "Clear Memory" was performed

### 7. MALFUNCTION INDICATOR LIGHT CLEAR CONDITION

- When the OK driving cycle was completed 3 times in a row
- When "Clear Memory" was performed

### 8. FAIL SAFE

Control the shift to be fixed in 3rd gear.

### 9. ECM OPERATION AT DTC SETTING

Memorize the freeze frame data. (For test mode \$02)

# Diagnostic Trouble Code (DTC) Detecting Criteria

## GENERAL DESCRIPTION

### CM:DTC P0753 SHIFT SOLENOID “A” ELECTRICAL

#### 1. OUTLINE OF DIAGNOSIS

Judge NG when the shift solenoid 1 becomes battery short, ground short or open circuit.

#### 2. COMPONENT DESCRIPTION

Shift solenoid 1 Shift solenoid is installed to the transmission hydraulic control valve body. This solenoid is switched on or off by the signal from TCM. Gear positions will change depending on the solenoid condition which is ON or OFF.

#### 3. ENABLE CONDITION

Secondary Parameters	Enable Conditions
None	

#### 4. GENERAL DRIVING CYCLE

Always perform the diagnosis continuously.

#### 5. DIAGNOSTIC METHOD

##### Judgment Value

Malfunction Criteria	Threshold Value
Collector voltage of transistor (Vc) for solenoid valve is inconsistent with signal from ECM	

**Time Needed for Diagnosis:** 30 milliseconds

**Malfunction Indicator Light Illumination:** Illuminates when malfunction occurs in 2 continuous driving cycles.

#### 6. DTC CLEAR CONDITION

- When the OK idling cycle was completed 40 times in a row
- When “Clear Memory” was performed

#### 7. MALFUNCTION INDICATOR LIGHT CLEAR CONDITION

- When the OK driving cycle was completed 3 times in a row
- When “Clear Memory” was performed

#### 8. FAIL SAFE

Control the shift to be fixed in 3rd gear.

#### 9. ECM OPERATION AT DTC SETTING

Memorize the freeze frame data. (For test mode \$02)

# Diagnostic Trouble Code (DTC) Detecting Criteria

GENERAL DESCRIPTION

## CN:DTC P0758 SHIFT SOLENOID “B” ELECTRICAL

### 1. OUTLINE OF DIAGNOSIS

Judge NG when the shift solenoid 2 becomes battery short, ground short or open circuit.

### 2. COMPONENT DESCRIPTION

Shift solenoid 2 Shift solenoid is installed to the transmission hydraulic control valve body. This solenoid is switched on or off by the signal from TCM. Gear positions will change depending on the solenoid condition which is ON or OFF.

### 3. ENABLE CONDITION

Secondary Parameters	Enable Conditions
None	

### 4. GENERAL DRIVING CYCLE

Always perform the diagnosis continuously.

### 5. DIAGNOSTIC METHOD

#### Judgment Value

Malfunction Criteria	Threshold Value
Vc for solenoid valve is inconsistent with signal from ECM	

**Time Needed for Diagnosis:** 30 milliseconds

**Malfunction Indicator Light Illumination:** Illuminates when malfunction occurs in 2 continuous driving cycles.

### 6. DTC CLEAR CONDITION

- When the OK idling cycle was completed 40 times in a row
- When “Clear Memory” was performed

### 7. MALFUNCTION INDICATOR LIGHT CLEAR CONDITION

- When the OK driving cycle was completed 3 times in a row
- When “Clear Memory” was performed

### 8. FAIL SAFE

Control the shift to be fixed in 3rd gear.

### 9. ECM OPERATION AT DTC SETTING

Memorize the freeze frame data. (For test mode \$02)

# Diagnostic Trouble Code (DTC) Detecting Criteria

## GENERAL DESCRIPTION

### CO:DTC P0771 SHIFT SOLENOID “E” PERFORMANCE OR STUCK OFF

#### 1. OUTLINE OF DIAGNOSIS

Judge NG when the low clutch timing solenoid becomes battery short, ground short or open circuit.

#### 2. COMPONENT DESCRIPTION

Low clutch timing solenoid Low clutch timing solenoid is installed to the transmission hydraulic control valve body. This solenoid is switched on or off by the signal from TCM. This allows controlling the low clutch timing valve B and reverse inhibitor valve.

#### 3. ENABLE CONDITION

Secondary Parameters	Enable Conditions
None	

#### 4. GENERAL DRIVING CYCLE

Always perform the diagnosis continuously.

#### 5. DIAGNOSTIC METHOD

##### Judgment Value

Malfunction Criteria	Threshold Value
Vc at “ON” signal from ECM	Low level
Vc at “OFF” signal from ECM	High level

**Time Needed for Diagnosis:** 30 milliseconds

**Malfunction Indicator Light Illumination:** Illuminates when malfunction occurs in 2 continuous driving cycles.

#### 6. DTC CLEAR CONDITION

- When the OK idling cycle was completed 40 times in a row
- When “Clear Memory” was performed

#### 7. MALFUNCTION INDICATOR LIGHT CLEAR CONDITION

- When the OK driving cycle was completed 3 times in a row
- When “Clear Memory” was performed

#### 8. FAIL SAFE

None

#### 9. ECM OPERATION AT DTC SETTING

Memorize the freeze frame data. (For test mode \$02)

# Diagnostic Trouble Code (DTC) Detecting Criteria

GENERAL DESCRIPTION

## CP:DTC P0778 PRESSURE CONTROL SOLENOID “B” ELECTRICAL

### 1. OUTLINE OF DIAGNOSIS

Judge NG when the 2-4 brake duty solenoid becomes battery short, ground short or open circuit.

### 2. COMPONENT DESCRIPTION

2-4 brake duty solenoid is installed to the transmission hydraulic control valve body. The duty ratio is controlled by the signal from TCM. This solenoid decreases the change gear shock by adjusting the 2-4 brake pressure during 2-4 brake operation.

### 3. ENABLE CONDITION

Secondary Parameters	Enable Conditions
None	

### 4. GENERAL DRIVING CYCLE

Always perform the diagnosis continuously.

### 5. DIAGNOSTIC METHOD

#### Judgment Value

Malfunction Criteria	Threshold Value
Vc at “ON” signal from ECM	Low level
Vc at “OFF” signal from ECM	High level

**Time Needed for Diagnosis:** 0.14 seconds

**Malfunction Indicator Light Illumination:** Illuminates when malfunction occurs in 2 continuous driving cycles.

### 6. DTC CLEAR CONDITION

- When the OK idling cycle was completed 40 times in a row
- When “Clear Memory” was performed

### 7. MALFUNCTION INDICATOR LIGHT CLEAR CONDITION

- When the OK driving cycle was completed 3 times in a row
- When “Clear Memory” was performed

### 8. FAIL SAFE

Control the shift to be fixed in 3rd gear.

### 9. ECM OPERATION AT DTC SETTING

Memorize the freeze frame data. (For test mode \$02)

# Diagnostic Trouble Code (DTC) Detecting Criteria

## GENERAL DESCRIPTION

### CQ:DTC P0785 SHIFT/TIMING SOLENOID

#### 1. OUTLINE OF DIAGNOSIS

Judge NG when the 2-4 brake timing solenoid becomes battery short, ground short or open circuit.

#### 2. COMPONENT DESCRIPTION

2-4 brake timing solenoid is installed to the transmission hydraulic control valve body. This solenoid is switched on or off by the signal from TCM. This allows controlling the 2-4 brake timing valve B and decreases the change gear shock.

#### 3. ENABLE CONDITION

Secondary Parameters	Enable Conditions
None	

#### 4. GENERAL DRIVING CYCLE

Always perform the diagnosis continuously.

#### 5. DIAGNOSTIC METHOD

##### Judgment Value

Malfunction Criteria	Threshold Value
Vc at "ON" signal from ECM	Low level
Vc at "OFF" signal from ECM	High level

**Time Needed for Diagnosis:** 30 milliseconds

**Malfunction Indicator Light Illumination:** Illuminates when malfunction occurs in 2 continuous driving cycles.

#### 6. DTC CLEAR CONDITION

- When the OK idling cycle was completed 40 times in a row
- When "Clear Memory" was performed

#### 7. MALFUNCTION INDICATOR LIGHT CLEAR CONDITION

- When the OK driving cycle was completed 3 times in a row
- When "Clear Memory" was performed

#### 8. FAIL SAFE

None

#### 9. ECM OPERATION AT DTC SETTING

Memorize the freeze frame data. (For test mode \$02)

# Diagnostic Trouble Code (DTC) Detecting Criteria

GENERAL DESCRIPTION

## CR:DTC P0851 NEUTRAL SWITCH INPUT CIRCUIT LOW (AT MODEL)

### 1. OUTLINE OF DIAGNOSIS

Detect the open or short circuit of the neutral SW.

Judge NG when the ECM neutral terminal input differs from the reception data from TCM.

### 2. ENABLE CONDITION

Secondary Parameters	Enable Conditions
Ignition switch	ON
Battery voltage	$\geq 10.9 \text{ V}$
After starting the engine	2 seconds or more
Starter switch	OFF
Engine speed	$\geq 500 \text{ rpm}$

### 3. GENERAL DRIVING CYCLE

Perform the diagnosis continuously in 2 seconds or more after starting the engine.

### 4. DIAGNOSTIC METHOD

Judge NG when the continuous time of completing the malfunction criteria below becomes more than 100 seconds. Judge OK and clear NG when the malfunction criteria below are not completed.

#### Judgment Value

Malfunction Criteria	Threshold Value
Neutral switch signal when park/neutral = "ON" & any other switches = "OFF" on AT	OFF

**Time Needed for Diagnosis:** 100 seconds

**Malfunction Indicator Light Illumination:** Illuminates when malfunction occurs in 2 continuous driving cycles.

### 5. DTC CLEAR CONDITION

- When the OK idling cycle was completed 40 times in a row
- When "Clear Memory" was performed

### 6. MALFUNCTION INDICATOR LIGHT CLEAR CONDITION

- When the OK driving cycle was completed 3 times in a row
- When "Clear Memory" was performed

### 7. FAIL SAFE

None

### 8. ECM OPERATION AT DTC SETTING

Memorize the freeze frame data. (For test mode \$02)



# Diagnostic Trouble Code (DTC) Detecting Criteria

## GENERAL DESCRIPTION

### CS:DTC P0851 NEUTRAL SWITCH INPUT CIRCUIT LOW (MT MODEL)

#### 1. OUTLINE OF DIAGNOSIS

Judge the open or short circuit of the neutral SW.

Judge NG when there is no change in the neutral SW even if the driving shift was applied. (There is neutral SW ON/OFF inversion from the vehicle speed and engine speed.)

#### 2. ENABLE CONDITION

Secondary Parameters	Enable Conditions
Ignition switch	ON
Battery voltage	$\geq 10.9 \text{ V}$
After starting the engine	2 seconds or more
Starter switch	OFF
Engine speed	$\geq 500 \text{ rpm}$

#### 3. GENERAL DRIVING CYCLE

Perform the diagnosis continuously in 2 seconds or more after starting the engine.

#### 4. DIAGNOSTIC METHOD

Judge NG when the malfunction criteria below are completed 3 time or more after the neutral SW change. And clear NG if there is change in the neutral SW.

##### Judgment Value

Malfunction Criteria	Threshold Value
Neutral switch signal (while changing from a to b below)	ON continues
Driving condition change	a) to b)
a) Vehicle speed = 0 km/h (0 MPH) & engine speed 600 — 900 rpm	
b) Vehicle speed = 64 km/h (40 MPH) & engine speed 1,600 — 2,550 rpm	

**Time Needed for Diagnosis:** 3 monitoring

**Malfunction Indicator Light Illumination:** Illuminates when malfunction occurs in 2 continuous driving cycles.

#### 5. DTC CLEAR CONDITION

- When the OK idling cycle was completed 40 times in a row
- When "Clear Memory" was performed

#### 6. MALFUNCTION INDICATOR LIGHT CLEAR CONDITION

- When the OK driving cycle was completed 3 times in a row
- When "Clear Memory" was performed

#### 7. FAIL SAFE

None

#### 8. ECM OPERATION AT DTC SETTING

Memorize the freeze frame data. (For test mode \$02)

# Diagnostic Trouble Code (DTC) Detecting Criteria

GENERAL DESCRIPTION

## CT:DTC P0852 NEUTRAL SWITCH INPUT CIRCUIT HIGH (AT MODEL)

### 1. OUTLINE OF DIAGNOSIS

Detect the open or short circuit of the neutral SW.

Judge NG when the ECM neutral terminal input differs from the reception data from TCM.

### 2. ENABLE CONDITION

Secondary Parameters	Enable Conditions
Ignition switch	ON
Battery voltage	$\geq 10.9 \text{ V}$
After starting the engine	2 seconds or more
Starter switch	OFF
Engine speed	$\geq 500 \text{ rpm}$

### 3. GENERAL DRIVING CYCLE

Perform the diagnosis continuously in 2 seconds or more after starting the engine.

### 4. DIAGNOSTIC METHOD

Judge NG when the continuous time until completing the malfunction criteria below becomes more than 100 seconds. Judge OK and clear NG when the malfunction criteria below are not completed.

#### Judgment Value

Malfunction Criteria	Threshold Value
Neutral switch signal when park/neutral = "OFF" & any other switches = "ON" on AT	ON

**Time Needed for Diagnosis:** 100 seconds

**Malfunction Indicator Light Illumination:** Illuminates when malfunction occurs in 2 continuous driving cycles.

### 5. DTC CLEAR CONDITION

- When the OK idling cycle was completed 40 times in a row
- When "Clear Memory" was performed

### 6. MALFUNCTION INDICATOR LIGHT CLEAR CONDITION

- When the OK driving cycle was completed 3 times in a row
- When "Clear Memory" was performed

### 7. FAIL SAFE

None

### 8. ECM OPERATION AT DTC SETTING

Memorize the freeze frame data. (For test mode \$02)

# Diagnostic Trouble Code (DTC) Detecting Criteria

## GENERAL DESCRIPTION

### CU:DTC P0852 NEUTRAL SWITCH INPUT CIRCUIT HIGH (MT MODEL)

#### 1. OUTLINE OF DIAGNOSIS

Judge the open or short circuit of the neutral SW.

Judge NG when there is no change in the neutral SW even if the driving shift was applied. (There is neutral SW ON/OFF inversion from the vehicle speed and engine speed.)

#### 2. ENABLE CONDITION

Secondary Parameters	Enable Conditions
Ignition switch	ON
Battery voltage	$\geq 10.9 \text{ V}$
After starting the engine	2 seconds or more
Starter switch	OFF
Engine speed	$\geq 500 \text{ rpm}$

#### 3. GENERAL DRIVING CYCLE

Perform the diagnosis continuously in 2 seconds or more after starting the engine.

#### 4. DIAGNOSTIC METHOD

Judge NG when the malfunction criteria below are completed 3 time or more after the neutral SW change. And clear NG if there is change in the neutral SW.

##### Judgment Value

Malfunction Criteria	Threshold Value
Neutral switch signal (while changing from a to b below)	OFF continues
Driving condition change	a) to b)
a) Vehicle speed = 0 km/h (0 MPH) & engine speed 600 — 900 rpm	
b) Vehicle speed = 64 km/h (40 MPH) & engine speed 1,600 — 2,550 rpm	

**Time Needed for Diagnosis:** 3 monitoring

**Malfunction Indicator Light Illumination:** Illuminates when malfunction occurs in 2 continuous driving cycles.

#### 5. DTC CLEAR CONDITION

- When the OK idling cycle was completed 40 times in a row
- When "Clear Memory" was performed

#### 6. MALFUNCTION INDICATOR LIGHT CLEAR CONDITION

- When the OK driving cycle was completed 3 times in a row
- When "Clear Memory" was performed

#### 7. FAIL SAFE

None

#### 8. ECM OPERATION AT DTC SETTING

Memorize the freeze frame data. (For test mode \$02)

# Diagnostic Trouble Code (DTC) Detecting Criteria

GENERAL DESCRIPTION

## CV:DTC P0864 TCM COMMUNICATION CIRCUIT RANGE/PERFORMANCE

### 1. OUTLINE OF DIAGNOSIS

Detect malfunction of communication of AT diagnosis.  
Judge NG when communication format is disagreement.

### 2. ENABLE CONDITION

Secondary Parameters	Enable Conditions
Ignition switch	ON
Battery voltage	$\geq 10.9 \text{ V}$
Engine speed	$\geq 500 \text{ rpm}$
Vehicle speed	$> 0 \text{ km/h (0 MPH)}$

### 3. GENERAL DRIVING CYCLE

Perform diagnosis during the vehicle running.

### 4. DIAGNOSTIC METHOD

Judge NG when the continuous time of completing the malfunction criteria below becomes more than the time needed for diagnosis (60 seconds). Judge OK and clear NG when receiving normal data.

#### Judgment Value

Malfunction Criteria	Threshold Value
AT malfunction data reception control	Not receive normal data

**Time Needed for Diagnosis:** 60 seconds

**Malfunction Indicator Light Illumination:** Illuminates when malfunction occurs in 2 continuous driving cycles.

### 5. DTC CLEAR CONDITION

- When the OK idling cycle was completed 40 times in a row
- When "Clear Memory" was performed

### 6. MALFUNCTION INDICATOR LIGHT CLEAR CONDITION

- When the OK driving cycle was completed 3 times in a row
- When "Clear Memory" was performed

### 7. FAIL SAFE

None

### 8. ECM OPERATION AT DTC SETTING

Memorize the freeze frame data. (For test mode \$02)

# Diagnostic Trouble Code (DTC) Detecting Criteria

## GENERAL DESCRIPTION

### CW:DTC P0865 TCM COMMUNICATION CIRCUIT LOW

#### 1. OUTLINE OF DIAGNOSIS

Detect open or short circuit in AT diagnosis line.  
Judge NG when the AT diagnosis input line signal remains Low.

#### 2. COMPONENT DESCRIPTION

Data frame as “Start signal (Low\_40 ms + High\_20 ms) → Data → End signal” is transmitted every approx. 1 second.

#### 3. ENABLE CONDITION

Secondary Parameters	Enable Conditions
Ignition switch	ON
Battery voltage	≥ 10.9 V
Engine speed	≥ 500 rpm
Vehicle speed	> 0 km/h (0 MPH)

#### 4. GENERAL DRIVING CYCLE

Perform diagnosis during the vehicle running.

#### 5. DIAGNOSTIC METHOD

Judge NG when the continuous time of completing the malfunction criteria below becomes more than the time needed for diagnosis (3 seconds). Judge OK and clear NG when the malfunction criteria below are not completed.

##### Judgment Value

Malfunction Criteria	Threshold Value
AT diagnosis input line signal	Low

**Time Needed for Diagnosis:** 3 seconds

**Malfunction Indicator Light Illumination:** Illuminates when malfunction occurs in two continuous drive cycles.

#### 6. DTC CLEAR CONDITION

- When the OK idling cycle was completed 40 times in a row
- When “Clear Memory” was performed

#### 7. MALFUNCTION INDICATOR LIGHT CLEAR CONDITION

- When the OK driving cycle was completed 3 times in a row
- When “Clear Memory” was performed

#### 8. FAIL SAFE

None

#### 9. ECM OPERATION AT DTC SETTING

Memorize the freeze frame data. (For test mode \$02)

# Diagnostic Trouble Code (DTC) Detecting Criteria

GENERAL DESCRIPTION

## CX:DTC P0866 TCM COMMUNICATION CIRCUIT HIGH

### 1. OUTLINE OF DIAGNOSIS

Detect open or short circuit in AT diagnosis line.

Judge NG when the AT diagnosis input line signal remains High.

### 2. COMPONENT DESCRIPTION

Data frame as "Start signal (Low\_40 ms + High\_20 ms) → Data → End signal" is transmitted every approx. 1 second.

### 3. ENABLE CONDITION

Secondary Parameters	Enable Conditions
Ignition switch	ON
Battery voltage	≥ 10.9 V
Engine speed	≥ 500 rpm
Vehicle speed	> 0 km/h (0 MPH)

### 4. GENERAL DRIVING CYCLE

Perform diagnosis during the vehicle running.

### 5. DIAGNOSTIC METHOD

Judge NG when the continuous time until completing the malfunction criteria below becomes more than the time needed for diagnosis (3 seconds). Judge OK and clear NG when the malfunction criteria below are not completed.

#### Judgment Value

Malfunction Criteria	Threshold Value
AT diagnosis input line signal	High

**Time Needed for Diagnosis:** 3 seconds

**Malfunction Indicator Light Illumination:** Illuminates when malfunction occurs in two continuous drive cycles.

### 6. DTC CLEAR CONDITION

- When the OK idling cycle was completed 40 times in a row
- When "Clear Memory" was performed

### 7. MALFUNCTION INDICATOR LIGHT CLEAR CONDITION

- When the OK driving cycle was completed 3 times in a row
- When "Clear Memory" was performed

### 8. FAIL SAFE

None

### 9. ECM OPERATION AT DTC SETTING

Memorize the freeze frame data. (For test mode \$02)

# Diagnostic Trouble Code (DTC) Detecting Criteria

## GENERAL DESCRIPTION

### CY:DTC P1086 TUMBLE GENERATED VALVE POSITION SENSOR 2 CIRCUIT LOW

#### 1. OUTLINE OF DIAGNOSIS

Detect open or short circuit of tumble generated valve position sensor.  
Judge NG when the value is out of standard range.

#### 2. COMPONENT DESCRIPTION

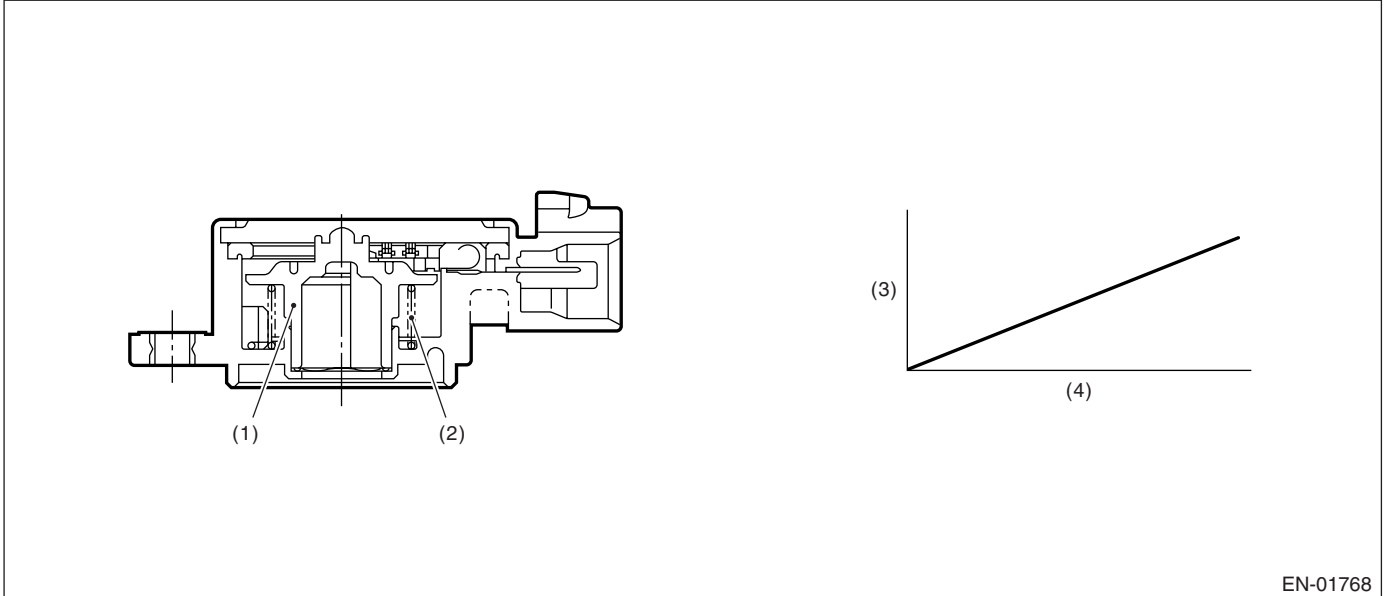

- (1) Rotor
- (2) Return spring
- (3) Voltage (V)
- (4) Tumble generated valve angle (°)

#### 3. ENABLE CONDITION

Secondary Parameters	Enable Conditions
None	

#### 4. GENERAL DRIVING CYCLE

Always perform diagnosis.

#### 5. DIAGNOSTIC METHOD

Judge NG when the continuous time of completing the malfunction criteria below becomes more than the time needed for diagnosis (0.5 seconds). Judge OK and clear NG when the malfunction criteria below are not completed.

##### Judgment Value

Malfunction Criteria	Threshold Value
Output voltage	< 0.135 V

**Time Needed for Diagnosis:** 0.5 seconds

**Malfunction Indicator Light Illumination:** Illuminates as soon as malfunction occurs.

#### 6. DTC CLEAR CONDITION

- When the OK idling cycle was completed 40 times in a row
- When "Clear Memory" was performed

## Diagnostic Trouble Code (DTC) Detecting Criteria

GENERAL DESCRIPTION

### 7. MALFUNCTION INDICATOR LIGHT CLEAR CONDITION

- When the OK driving cycle was completed 3 times in a row
- When "Clear Memory" was performed

### 8. FAIL SAFE

Tumble generated valve position

- Learning of tumble generated valve position fully closed and date renewed to close side.
- Learning of tumble generated valve position fully opened and date renewed to open side.

### 9. ECM OPERATION AT DTC SETTING

Memorize the freeze frame data. (For test mode \$02)



# Diagnostic Trouble Code (DTC) Detecting Criteria

## GENERAL DESCRIPTION

### CZ:DTC P1087 TUMBLE GENERATED VALVE POSITION SENSOR 2 CIRCUIT HIGH

#### 1. OUTLINE OF DIAGNOSIS

Detect open or short circuit of tumble generated valve position sensor.  
Judge NG when the value is out of standard range.

#### 2. COMPONENT DESCRIPTION

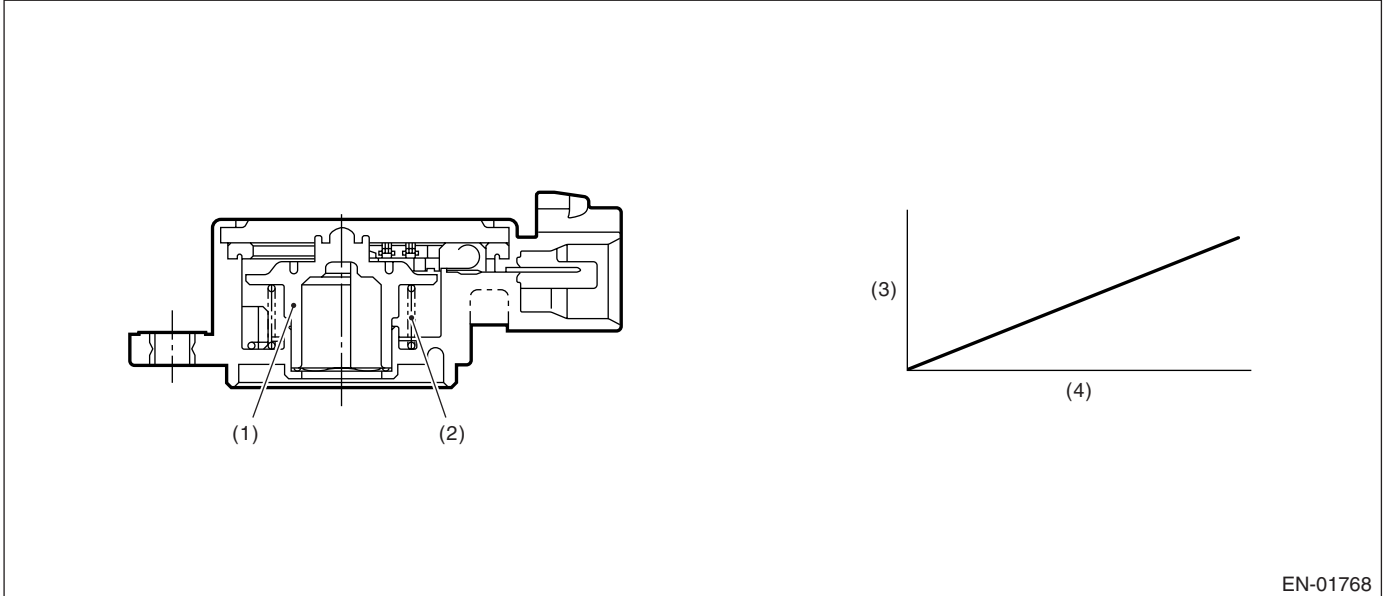

- (1) Rotor
- (2) Return spring
- (3) Voltage (V)
- (4) Tumble generated valve angle (°)

#### 3. ENABLE CONDITION

Secondary Parameters	Enable Conditions
None	

#### 4. GENERAL DRIVING CYCLE

Always perform diagnosis.

#### 5. DIAGNOSTIC METHOD

Judge NG when the continuous time of completing the malfunction criteria below becomes more than the time needed for diagnosis (0.5 seconds). Judge OK and clear NG when the malfunction criteria below are not completed.

##### Judgment Value

Malfunction Criteria	Threshold Value
Output voltage	$\geq 4.85$ V

**Time Needed for Diagnosis:** 0.5 seconds

**Malfunction Indicator Light Illumination:** Illuminates as soon as malfunction occurs.

#### 6. DTC CLEAR CONDITION

- When the OK idling cycle was completed 40 times in a row
- When "Clear Memory" was performed

## Diagnostic Trouble Code (DTC) Detecting Criteria

GENERAL DESCRIPTION

### 7. MALFUNCTION INDICATOR LIGHT CLEAR CONDITION

- When the OK driving cycle was completed 3 times in a row
- When "Clear Memory" was performed

### 8. FAIL SAFE

Tumble generated valve position

- Learning of tumble generated valve position fully closed and date renewed to close side.
- Learning of tumble generated valve position fully opened and date renewed to open side.

### 9. ECM OPERATION AT DTC SETTING

Memorize the freeze frame data. (For test mode \$02)

# Diagnostic Trouble Code (DTC) Detecting Criteria

## GENERAL DESCRIPTION

### DA:DTC P1088 TUMBLE GENERATED VALVE POSITION SENSOR 1 CIRCUIT LOW

#### 1. OUTLINE OF DIAGNOSIS

Detect open or short circuit of tumble generated valve position sensor.  
Judge NG when the value is out of standard range.

#### 2. COMPONENT DESCRIPTION

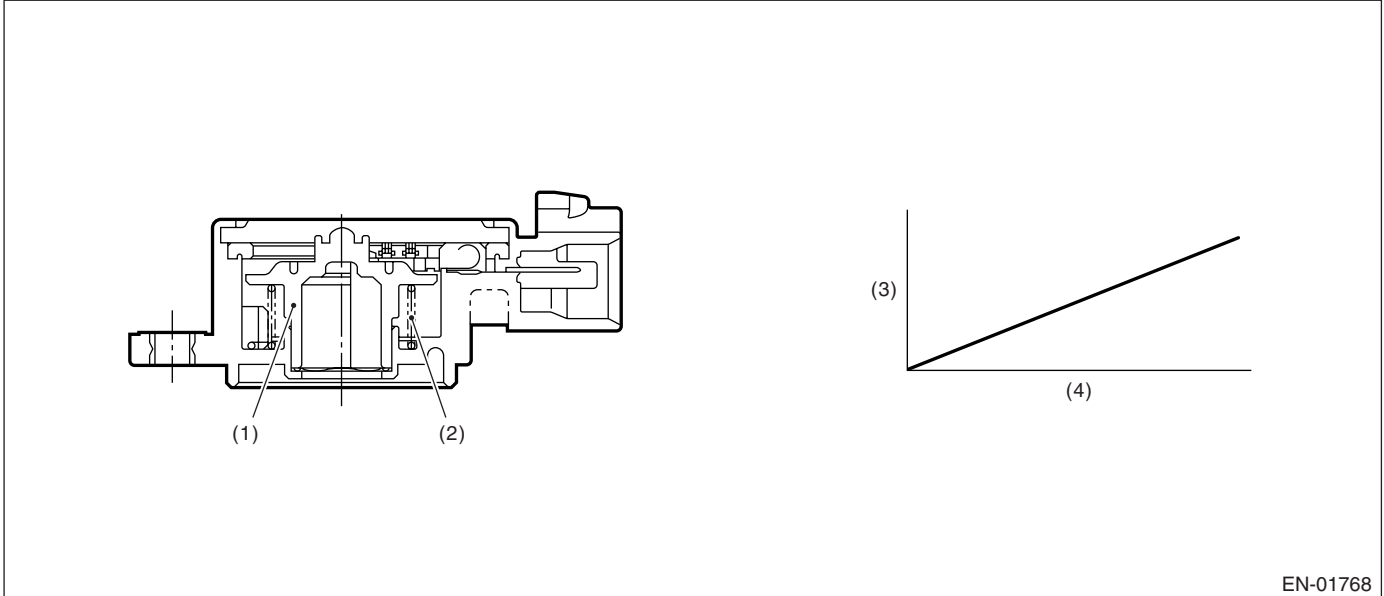

- (1) Rotor
- (2) Return spring
- (3) Voltage (V)
- (4) Tumble generated valve angle (°)

#### 3. ENABLE CONDITION

Secondary Parameters	Enable Conditions
None	

#### 4. GENERAL DRIVING CYCLE

Always perform diagnosis.

#### 5. DIAGNOSTIC METHOD

Judge NG when the continuous time of completing the malfunction criteria below becomes more than the time needed for diagnosis (0.5 seconds). Judge OK and clear NG when the malfunction criteria below are not completed.

##### Judgment Value

Malfunction Criteria	Threshold Value
Output voltage	< 0.135 V

**Time Needed for Diagnosis:** 0.5 seconds

**Malfunction Indicator Light Illumination:** Illuminates as soon as malfunction occurs.

#### 6. DTC CLEAR CONDITION

- When the OK idling cycle was completed 40 times in a row
- When "Clear Memory" was performed

## Diagnostic Trouble Code (DTC) Detecting Criteria

GENERAL DESCRIPTION

### 7. MALFUNCTION INDICATOR LIGHT CLEAR CONDITION

- When the OK driving cycle was completed 3 times in a row
- When "Clear Memory" was performed

### 8. FAIL SAFE

Tumble generated valve position

- Learning of tumble generated valve position fully closed and date renewed to close side.
- Learning of tumble generated valve position fully opened and date renewed to open side.

### 9. ECM OPERATION AT DTC SETTING

Memorize the freeze frame data. (For test mode \$02)

# Diagnostic Trouble Code (DTC) Detecting Criteria

GENERAL DESCRIPTION

## DB:DTC P1089 TUMBLE GENERATED VALVE POSITION SENSOR 1 CIRCUIT HIGH

### 1. OUTLINE OF DIAGNOSIS

Detect open or short circuit of tumble generated valve position sensor.  
Judge NG when the value is out of standard range.

### 2. COMPONENT DESCRIPTION

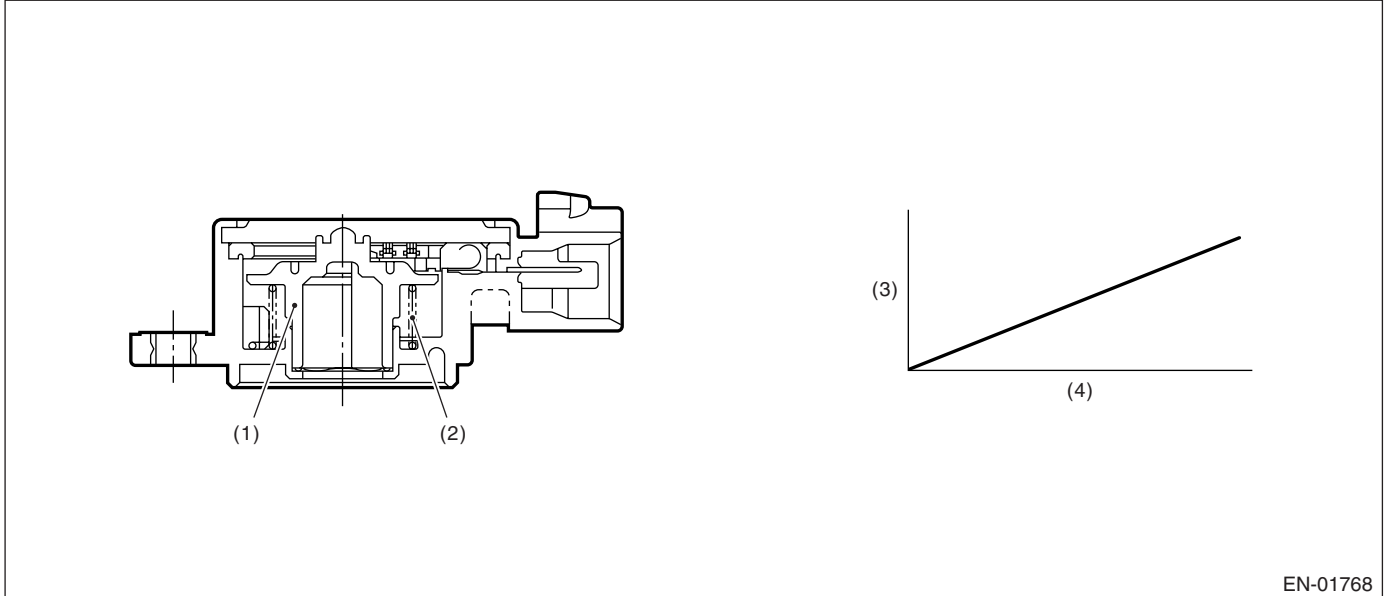

- (1) Rotor
- (2) Return spring
- (3) Voltage (V)
- (4) Tumble generated valve angle (°)

### 3. ENABLE CONDITION

Secondary Parameters	Enable Conditions
None	

### 4. GENERAL DRIVING CYCLE

Always perform diagnosis.

### 5. DIAGNOSTIC METHOD

Judge NG when the continuous time of completing the malfunction criteria below becomes more than the time needed for diagnosis (0.5 seconds). Judge OK and clear NG when the malfunction criteria below are not completed.

#### Judgment Value

Malfunction Criteria	Threshold Value
Output voltage	$\geq 4.85$ V

**Time Needed for Diagnosis:** 0.5 seconds

**Malfunction Indicator Light Illumination:** Illuminates as soon as malfunction occurs.

### 6. DTC CLEAR CONDITION

- When the OK idling cycle was completed 40 times in a row
- When "Clear Memory" was performed

## Diagnostic Trouble Code (DTC) Detecting Criteria

GENERAL DESCRIPTION

### 7. MALFUNCTION INDICATOR LIGHT CLEAR CONDITION

- When the OK driving cycle was completed 3 times in a row
- When "Clear Memory" was performed

### 8. FAIL SAFE

Tumble generated valve position

- Learning of tumble generated valve position fully closed and date renewed to close side.
- Learning of tumble generated valve position fully opened and date renewed to open side.

### 9. ECM OPERATION AT DTC SETTING

Memorize the freeze frame data. (For test mode \$02)

# Diagnostic Trouble Code (DTC) Detecting Criteria

## GENERAL DESCRIPTION

### DC:DTC P1090 TUMBLE GENERATED VALVE SYSTEM 1 (VALVE OPEN)

#### 1. OUTLINE OF DIAGNOSIS

Detect the malfunction of tumble generated valve motor function.

Judge open fixing malfunction when the opening degree is large even after finishing the tumble generated valve open driving.

#### 2. ENABLE CONDITION

Secondary Parameters	Enable Conditions
Battery voltage	$\geq 10.9 \text{ V}$
Engine coolant temperature	$\geq 0^{\circ}\text{C}$ (32°F)

#### 3. GENERAL DRIVING CYCLE

Always perform the diagnosis continuously.

#### 4. DIAGNOSTIC METHOD

##### • Abnormality Judgment

Judge NG when the continuous time of completing the malfunction criteria below becomes more than 3 seconds.

##### Judgment Value

Malfunction Criteria	Threshold Value
Tumble generated valve angle	$\geq 67.4^{\circ}$
Tumble generated valve "close" signal output	1.4 seconds or more

**Time Needed for Diagnosis:** 3 seconds

**Malfunction Indicator Light Illumination:** Illuminates as soon as malfunction occurs.

##### • Normality Judgment

Judge OK and clear the NG when the malfunction criteria below are completed.

##### Judgment Value

Malfunction Criteria	Threshold Value
Tumble generated valve angle	$< 67.4^{\circ}$
Tumble generated valve "close" signal output	1.4 seconds or more

#### 5. DTC CLEAR CONDITION

- When the OK idling cycle was completed 40 times in a row
- When "Clear Memory" was performed

#### 6. MALFUNCTION INDICATOR LIGHT CLEAR CONDITION

- When the OK driving cycle was completed 3 times in a row
- When "Clear Memory" was performed

#### 7. FAIL SAFE

Tumble generated valve opening

- For tumble generated valve all closing points learning, not allowed to update to the closing side.
- For tumble generated valve all opening points learning, not allowed to update to the opening side.

Tumble generated valve control

- Output the open signal.

#### 8. ECM OPERATION AT DTC SETTING

Memorize the freeze frame data. (For test mode \$02)

# Diagnostic Trouble Code (DTC) Detecting Criteria

GENERAL DESCRIPTION

## DD:DTC P1091 TUMBLE GENERATED VALVE SYSTEM 1 (VALVE CLOSE)

### 1. OUTLINE OF DIAGNOSIS

Detect the malfunction of tumble generated valve motor function.

Judge close fixing malfunction when the opening degree is small even after finishing the tumble generated valve open driving.

### 2. ENABLE CONDITION

Secondary Parameters	Enable Conditions
Battery voltage	$\geq 10.9$ V
Engine coolant temperature	$\geq 0^{\circ}\text{C}$ ( $32^{\circ}\text{F}$ )

### 3. GENERAL DRIVING CYCLE

Always perform the diagnosis continuously.

### 4. DIAGNOSTIC METHOD

#### • Abnormality Judgment

Judge NG when the continuous time of completing the malfunction criteria below becomes more than 3 seconds.

#### Judgment Value

Malfunction Criteria	Threshold Value
Tumble generated valve angle	$< 67.4^{\circ}$
Tumble generated valve "open" signal output	1.4 seconds or more

**Time Needed for Diagnosis:** 3 seconds

**Malfunction Indicator Light Illumination:** Illuminates as soon as malfunction occurs.

#### • Normality Judgment

Judge OK and clear the NG when the malfunction criteria below are completed.

#### Judgment Value

Malfunction Criteria	Threshold Value
Tumble generated valve angle	$\geq 67.4^{\circ}$
Tumble generated valve "open" signal output	1.4 seconds or more

### 5. DTC CLEAR CONDITION

- When the OK idling cycle was completed 40 times in a row
- When "Clear Memory" was performed

### 6. MALFUNCTION INDICATOR LIGHT CLEAR CONDITION

- When the OK driving cycle was completed 3 times in a row
- When "Clear Memory" was performed

### 7. FAIL SAFE

Tumble generated valve opening

- For tumble generated valve all closing points learning, not allowed to update to the closing side.
- For tumble generated valve all opening points learning, not allowed to update to the opening side.

Tumble generated valve control

- Output the close signal.

### 8. ECM OPERATION AT DTC SETTING

Memorize the freeze frame data. (For test mode \$02)



# Diagnostic Trouble Code (DTC) Detecting Criteria

## GENERAL DESCRIPTION

### DE:DTC P1092 TUMBLE GENERATED VALVE SYSTEM 2 (VALVE OPEN)

#### 1. OUTLINE OF DIAGNOSIS

Detect the malfunction of tumble generated valve motor function.

Judge open fixing malfunction when the opening degree is large even after finishing the tumble generated valve closing driving.

#### 2. ENABLE CONDITION

Secondary Parameters	Enable Conditions
Battery voltage	$\geq 10.9 \text{ V}$
Engine coolant temperature	$\geq 0^{\circ}\text{C}$ (32°F)

#### 3. GENERAL DRIVING CYCLE

Always perform the diagnosis continuously.

#### 4. DIAGNOSTIC METHOD

##### • Abnormality Judgment

Judge NG when the continuous time of completing the malfunction criteria below becomes more than 3 seconds.

##### Judgment Value

Malfunction Criteria	Threshold Value
Tumble generated valve angle	$\geq 67.4^{\circ}$
Tumble generated valve "close" signal output	1.4 seconds or more

**Time Needed for Diagnosis:** 3 seconds

**Malfunction Indicator Light Illumination:** Illuminates as soon as malfunction occurs.

##### • Normality Judgment

Judge OK and clear the NG when the malfunction criteria below are completed.

##### Judgment Value

Malfunction Criteria	Threshold Value
Tumble generated valve angle	$< 67.4^{\circ}$
Tumble generated valve "close" signal output	1.4 seconds or more

#### 5. DTC CLEAR CONDITION

- When the OK idling cycle was completed 40 times in a row
- When "Clear Memory" was performed

#### 6. MALFUNCTION INDICATOR LIGHT CLEAR CONDITION

- When the OK driving cycle was completed 3 times in a row
- When "Clear Memory" was performed

#### 7. FAIL SAFE

Tumble generated valve opening

- For tumble generated valve all closing points learning, not allowed to update to the closing side.
- For tumble generated valve all opening points learning, not allowed to update to the opening side.

Tumble generated valve control

- Output the open signal.

#### 8. ECM OPERATION AT DTC SETTING

Memorize the freeze frame data. (For test mode \$02)

# Diagnostic Trouble Code (DTC) Detecting Criteria

GENERAL DESCRIPTION

## DF:DTC P1093 TUMBLE GENERATED VALVE SYSTEM 2 (VALVE CLOSE)

### 1. OUTLINE OF DIAGNOSIS

Detect the malfunction of tumble generated valve motor function.

Judge close fixing malfunction when the opening degree is small even after finishing the tumble generated valve open driving.

### 2. ENABLE CONDITION

Secondary Parameters	Enable Conditions
Battery voltage	$\geq 10.9$ V
Engine coolant temperature	$\geq 0^{\circ}\text{C}$ ( $32^{\circ}\text{F}$ )

### 3. GENERAL DRIVING CYCLE

Always perform the diagnosis continuously.

### 4. DIAGNOSTIC METHOD

#### • Abnormality Judgment

Judge NG when the continuous time of completing the malfunction criteria below becomes more than 3 seconds.

#### Judgment Value

Malfunction Criteria	Threshold Value
Tumble generated valve angle	$< 67.4^{\circ}$
Tumble generated valve "open" signal output	1.4 seconds or more

**Time Needed for Diagnosis:** 3 seconds

**Malfunction Indicator Light Illumination:** Illuminates as soon as malfunction occurs.

#### • Normality Judgment

Judge OK and clear the NG when the malfunction criteria below are completed.

#### Judgment Value

Malfunction Criteria	Threshold Value
Tumble generated valve angle	$\geq 67.4^{\circ}$
Tumble generated valve "open" signal output	1.4 seconds or more

### 5. DTC CLEAR CONDITION

- When the OK idling cycle was completed 40 times in a row
- When "Clear Memory" was performed

### 6. MALFUNCTION INDICATOR LIGHT CLEAR CONDITION

- When the OK driving cycle was completed 3 times in a row
- When "Clear Memory" was performed

### 7. FAIL SAFE

Tumble generated valve opening

- For tumble generated valve all closing points learning, not allowed to update to the closing side.
- For tumble generated valve all opening points learning, not allowed to update to the opening side.

Tumble generated valve control

- Output the close signal.

### 8. ECM OPERATION AT DTC SETTING

Memorize the freeze frame data. (For test mode \$02)

# Diagnostic Trouble Code (DTC) Detecting Criteria

## GENERAL DESCRIPTION

### DG:DTC P1094 TUMBLE GENERATED VALVE SIGNAL 1 CIRCUIT MALFUNCTION (OPEN)

#### 1. OUTLINE OF DIAGNOSIS

Detect the open or short circuit of tumble generated valve motor.

Judge NG when the open signal is sent from IC after tumble generated valve driving IC diagnosis.

#### 2. COMPONENT DESCRIPTION

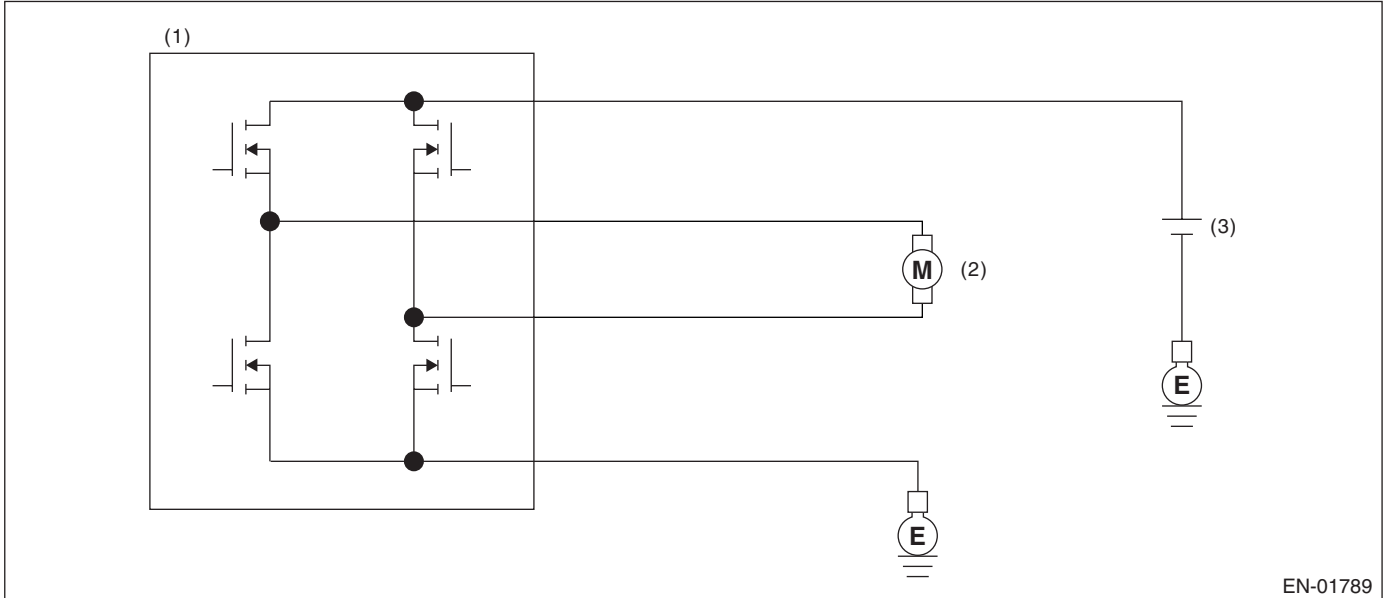

- (1) Engine control module (ECM)
- (2) Tumble generated valve
- (3) Battery

#### 3. ENABLE CONDITION

Secondary Parameters	Enable Conditions
Battery voltage	$\geq 10.9$ V

#### 4. GENERAL DRIVING CYCLE

Always perform the diagnosis continuously.

#### 5. DIAGNOSTIC METHOD

Judge NG when the malfunction criteria below are completed by tumble generated valve driving IC, and then NG signal is sent to main IC. At the main IC, judge NG when the NG signal is sent for 1 second in a row. Judge OK and clear the NG when the OK signal is sent.

##### Judgment Value

Malfunction Criteria	Threshold Value
Current	$< 5$ mA

**Time Needed for Diagnosis:** 10 seconds

**Malfunction Indicator Light Illumination:** Illuminates as soon as malfunction occurs.

#### 6. DTC CLEAR CONDITION

- When the OK idling cycle was completed 40 times in a row
- When "Clear Memory" was performed

## Diagnostic Trouble Code (DTC) Detecting Criteria

GENERAL DESCRIPTION

### 7. MALFUNCTION INDICATOR LIGHT CLEAR CONDITION

- When the OK driving cycle was completed 3 times in a row
- When "Clear Memory" was performed

### 8. FAIL SAFE

Tumble generated valve opening

- For tumble generated valve all closing points learning, not allowed to update to closing side.
- For tumble generated valve all opening points learning, not allowed to update to opening side.

Tumble generated valve control

- Not allowed to move.

### 9. ECM OPERATION AT DTC SETTING

Memorize the freeze frame data. (For test mode \$02)

# Diagnostic Trouble Code (DTC) Detecting Criteria

## GENERAL DESCRIPTION

### DH:DTC P1095 TUMBLE GENERATED VALVE SIGNAL 1 CIRCUIT MALFUNCTION (SHORT)

#### 1. OUTLINE OF DIAGNOSIS

Detect the open or short circuit of tumble generated valve motor.

Judge NG when the overcurrent signal is sent from IC after tumble generated valve driving IC diagnosis.

#### 2. COMPONENT DESCRIPTION

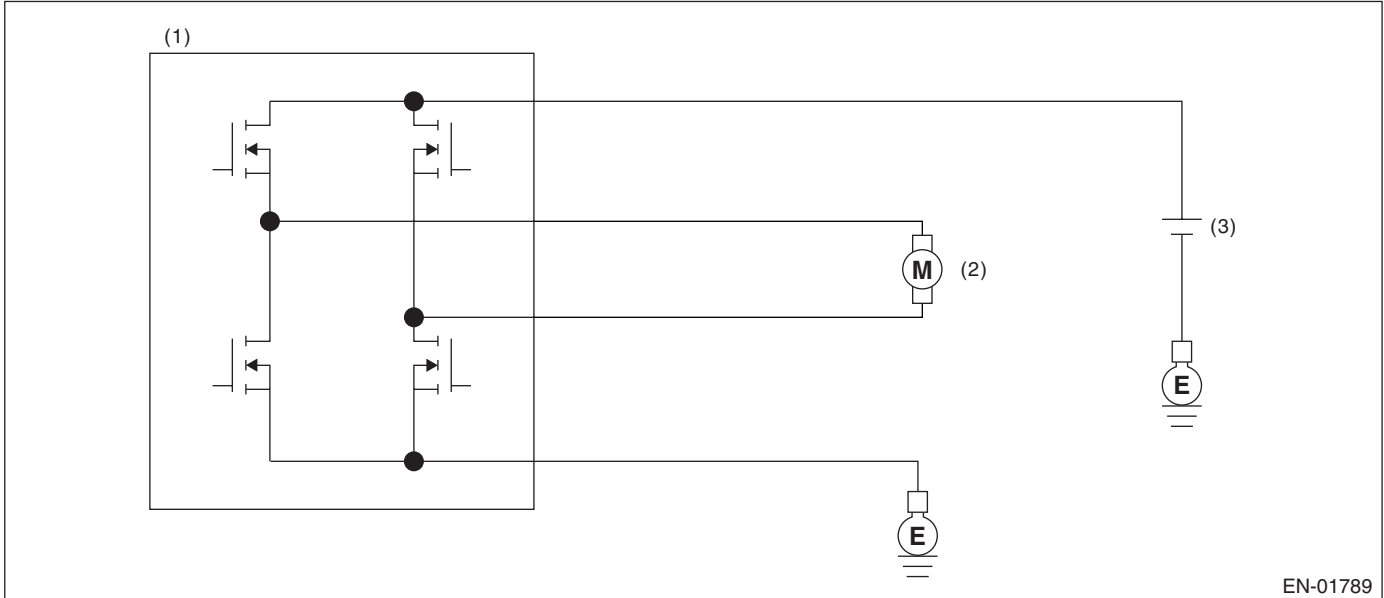

- (1) Engine control module (ECM)
- (2) Tumble generated valve
- (3) Battery

#### 3. ENABLE CONDITION

Secondary Parameters	Enable Conditions
Battery voltage	$\geq 10.9$ V

#### 4. GENERAL DRIVING CYCLE

Always perform the diagnosis continuously.

#### 5. DIAGNOSTIC METHOD

Judge NG when the malfunction criteria below are completed by tumble generated valve driving IC, and then NG signal is sent to main IC. At the main IC, judge NG when the NG signal is sent for 1 second in a row. Judge OK and clear the NG when the OK signal is sent.

##### Judgment Value

Malfunction Criteria	Threshold Value
Current	$> 3$ A

**Time Needed for Diagnosis:** 10 seconds

**Malfunction Indicator Light Illumination:** Illuminates as soon as malfunction occurs.

#### 6. DTC CLEAR CONDITION

- When the OK idling cycle was completed 40 times in a row
- When "Clear Memory" was performed

## Diagnostic Trouble Code (DTC) Detecting Criteria

GENERAL DESCRIPTION

### 7. MALFUNCTION INDICATOR LIGHT CLEAR CONDITION

- When the OK driving cycle was completed 3 times in a row
- When "Clear Memory" was performed

### 8. FAIL SAFE

Tumble generated valve opening

- For tumble generated valve all closing points learning, not allowed to update to closing side.
- For tumble generated valve all opening points learning, not allowed to update to opening side.

Tumble generated valve control

- Not allowed to move.

### 9. ECM OPERATION AT DTC SETTING

Memorize the freeze frame data. (For test mode \$02)

# Diagnostic Trouble Code (DTC) Detecting Criteria

## GENERAL DESCRIPTION

### DI: DTC P1096 TUMBLE GENERATED VALVE SIGNAL 2 CIRCUIT MALFUNCTION (OPEN)

#### 1. OUTLINE OF DIAGNOSIS

Detect the open or short circuit of tumble generated valve motor.

Judge NG when the open signal is sent from IC after tumble generated valve driving IC diagnosis.

#### 2. COMPONENT DESCRIPTION

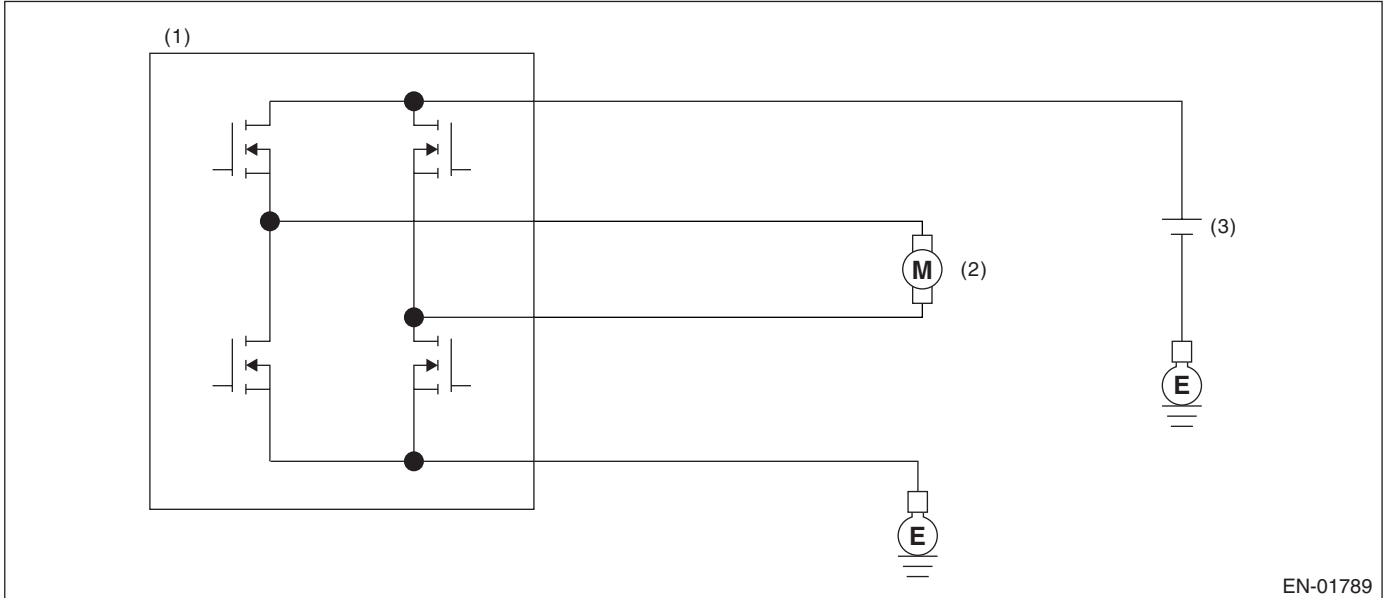

- (1) Engine control module (ECM)
- (2) Tumble generated valve
- (3) Battery

#### 3. ENABLE CONDITION

Secondary Parameters	Enable Conditions
Battery voltage	$\geq 10.9$ V

#### 4. GENERAL DRIVING CYCLE

Always perform the diagnosis continuously.

#### 5. DIAGNOSTIC METHOD

Judge NG when the malfunction criteria below are completed by tumble generated valve driving IC, and then NG signal is sent to main IC. At the main IC, judge NG when the NG signal is sent for 1 second in a row. Judge OK and clear the NG when the OK signal is sent.

##### Judgment Value

Malfunction Criteria	Threshold Value
Current	$< 5$ mA

**Time Needed for Diagnosis:** 10 seconds

**Malfunction Indicator Light Illumination:** Illuminates as soon as malfunction occurs.

#### 6. DTC CLEAR CONDITION

- When the OK idling cycle was completed 40 times in a row
- When "Clear Memory" was performed

## Diagnostic Trouble Code (DTC) Detecting Criteria

GENERAL DESCRIPTION

### 7. MALFUNCTION INDICATOR LIGHT CLEAR CONDITION

- When the OK driving cycle was completed 3 times in a row
- When "Clear Memory" was performed

### 8. FAIL SAFE

Tumble generated valve opening

- For tumble generated valve all closing points learning, not allowed to update to closing side.
- For tumble generated valve all opening points learning, not allowed to update to opening side.

Tumble generated valve control

- Not allowed to move.

### 9. ECM OPERATION AT DTC SETTING

Memorize the freeze frame data. (For test mode \$02)



# Diagnostic Trouble Code (DTC) Detecting Criteria

## GENERAL DESCRIPTION

### DJ:DTC P1097 TUMBLE GENERATED VALVE SIGNAL 2 CIRCUIT MALFUNCTION (SHORT)

#### 1. OUTLINE OF DIAGNOSIS

Detect the open or short circuit of tumble generated valve motor.

Judge NG when the overcurrent signal is sent from IC after tumble generated valve driving IC diagnosis.

#### 2. COMPONENT DESCRIPTION

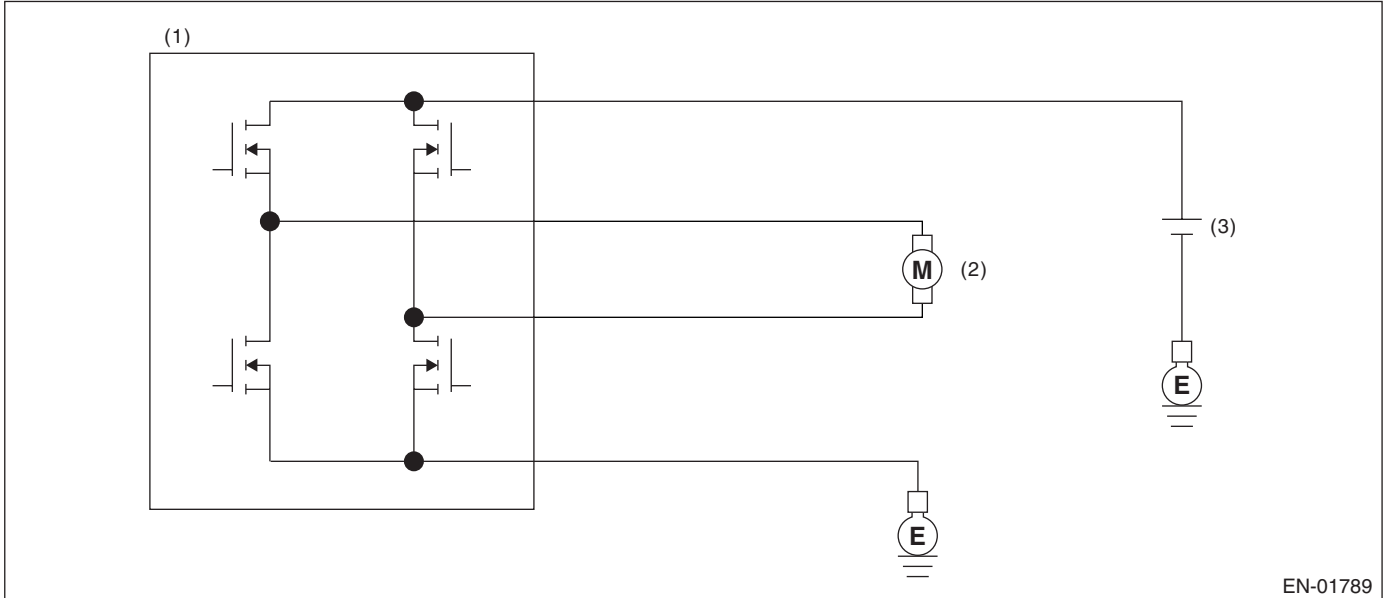

- (1) Engine control module (ECM)
- (2) Tumble generated valve
- (3) Battery

#### 3. ENABLE CONDITION

Secondary Parameters	Enable Conditions
Battery voltage	$\geq 10.9 \text{ V}$

#### 4. GENERAL DRIVING CYCLE

Always perform the diagnosis continuously.

#### 5. DIAGNOSTIC METHOD

Judge NG when the malfunction criteria below are completed by tumble generated valve driving IC, and then NG signal is sent to main IC. At the main IC, judge NG when the NG signal is sent for 1 second in a row. Judge OK and clear the NG when the OK signal is sent.

##### Judgment Value

Malfunction Criteria	Threshold Value
Current	$> 3 \text{ A}$

**Time Needed for Diagnosis:** 10 seconds

**Malfunction Indicator Light Illumination:** Illuminates as soon as malfunction occurs.

#### 6. DTC CLEAR CONDITION

- When the OK idling cycle was completed 40 times in a row
- When "Clear Memory" was performed

## Diagnostic Trouble Code (DTC) Detecting Criteria

GENERAL DESCRIPTION

### 7. MALFUNCTION INDICATOR LIGHT CLEAR CONDITION

- When the OK driving cycle was completed 3 times in a row
- When "Clear Memory" was performed

### 8. FAIL SAFE

Tumble generated valve opening

- For tumble generated valve all closing points learning, not allowed to update to closing side.
- For tumble generated valve all opening points learning, not allowed to update to opening side.

Tumble generated valve control

- Not allowed to move.

### 9. ECM OPERATION AT DTC SETTING

Memorize the freeze frame data. (For test mode \$02)

# Diagnostic Trouble Code (DTC) Detecting Criteria

## GENERAL DESCRIPTION

### DK:DTC P1110 ATMOSPHERIC PRESSURE SENSOR CIRCUIT MALFUNCTION (LOW INPUT)

#### 1. OUTLINE OF DIAGNOSIS

Detect the open or short circuit of atmospheric pressure sensor.  
Judge NG when out of the standard value.

#### 2. COMPONENT DESCRIPTION

Atmospheric pressure sensor is built in ECM.

#### 3. ENABLE CONDITION

Secondary Parameters	Enable Conditions
None	

#### 4. GENERAL DRIVING CYCLE

Always perform the diagnosis continuously.

#### 5. DIAGNOSTIC METHOD

##### • Abnormality Judgment

Judge NG when the continuous time of completing the malfunction criteria below becomes more than 0.5 seconds.

##### Judgment Value

Malfunction Criteria	Threshold Value
Ignition switch	ON
Output voltage	< 1.0 V

**Time Needed for Diagnosis:** 0.5 seconds

**Malfunction Indicator Light Illumination:** Illuminates as soon as malfunction occurs.

##### • Normality Judgment

Judge OK and clear the NG when the malfunction criteria below are completed.

##### Judgment Value

Malfunction Criteria	Threshold Value
Ignition switch	ON
Output voltage	≥ 1.0 V

#### 6. DTC CLEAR CONDITION

- When the OK idling cycle was completed 40 times in a row
- When "Clear Memory" was performed

#### 7. MALFUNCTION INDICATOR LIGHT CLEAR CONDITION

- When the OK driving cycle was completed 3 times in a row
- When "Clear Memory" was performed

#### 8. FAIL SAFE

Atmospheric pressure sensor process: Fix the atmospheric pressure to 101.3 kPa (760 mmHg, 29.9 inHg).

#### 9. ECM OPERATION AT DTC SETTING

Memorize the freeze frame data. (For test mode \$02)

# Diagnostic Trouble Code (DTC) Detecting Criteria

GENERAL DESCRIPTION

## DL:DTC P1111 ATMOSPHERIC PRESSURE SENSOR CIRCUIT MALFUNCTION (HIGH INPUT)

### 1. OUTLINE OF DIAGNOSIS

Detect the open or short circuit of atmospheric pressure sensor.  
Judge NG when out of the standard value.

### 2. COMPONENT DESCRIPTION

Atmospheric pressure sensor is built in ECM.

### 3. ENABLE CONDITION

Secondary Parameters	Enable Conditions
None	

### 4. GENERAL DRIVING CYCLE

Always perform the diagnosis continuously.

### 5. DIAGNOSTIC METHOD

#### • Abnormality Judgment

Judge NG when the continuous time of completing the malfunction criteria below becomes more than 0.5 seconds.

#### Judgment Value

Malfunction Criteria	Threshold Value
Ignition switch	ON
Output voltage	$\geq 4.78$ V

**Time Needed for Diagnosis:** 0.5 seconds

**Malfunction Indicator Light Illumination:** Illuminates as soon as malfunction occurs.

#### • Normality Judgment

Judge OK and clear the NG when the malfunction criteria below are completed.

#### Judgment Value

Malfunction Criteria	Threshold Value
Ignition switch	ON
Output voltage	$< 4.78$ V

### 6. DTC CLEAR CONDITION

- When the OK idling cycle was completed 40 times in a row
- When "Clear Memory" was performed

### 7. MALFUNCTION INDICATOR LIGHT CLEAR CONDITION

- When the OK driving cycle was completed 3 times in a row
- When "Clear Memory" was performed

### 8. FAIL SAFE

Atmospheric pressure sensor process: Fix the atmospheric pressure to 101.3 kPa (760 mmHg, 29.9 inHg).

### 9. ECM OPERATION AT DTC SETTING

Memorize the freeze frame data. (For test mode \$02)

# Diagnostic Trouble Code (DTC) Detecting Criteria

## GENERAL DESCRIPTION

### DM:DTC P1134 A/F SENSOR MICRO-COMPUTER PROBLEM

#### 1. OUTLINE OF DIAGNOSIS

Detect the malfunction of IC communication.  
Judge NG when the IC communication malfunction occurs.

#### 2. COMPONENT DESCRIPTION

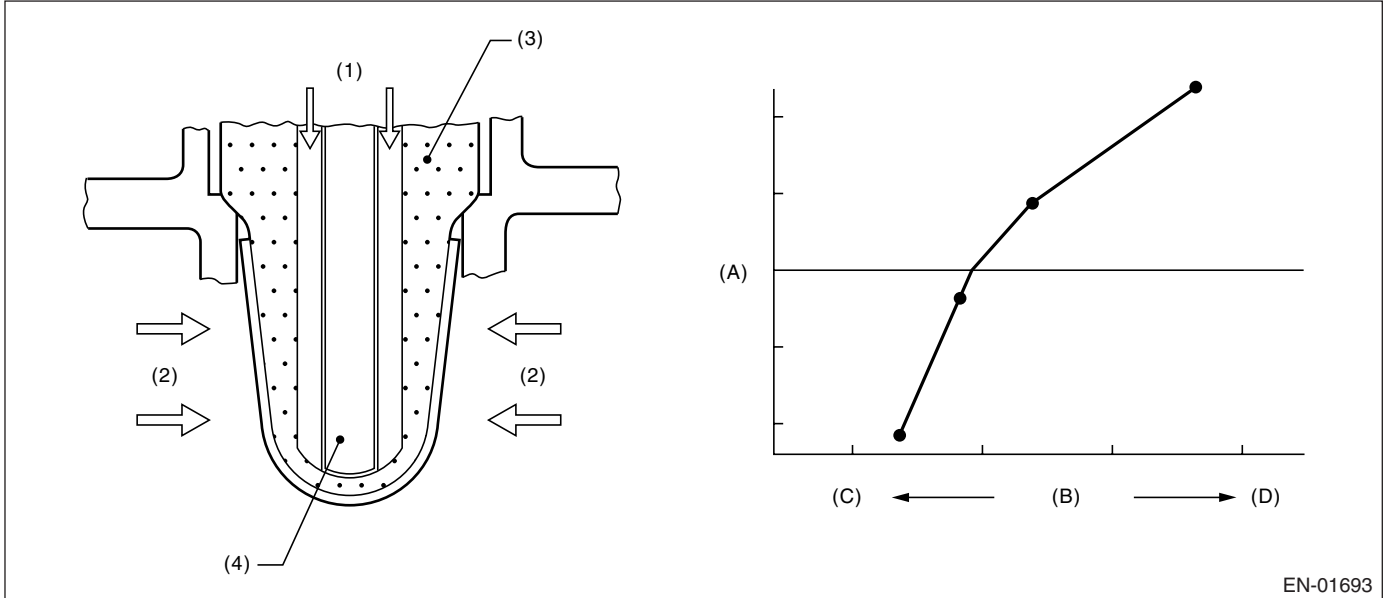

- (1) Atmosphere
- (2) Exhaust gas
- (3) ZrO<sub>2</sub>
- (4) Ceramic heater

- (A) Electromotive force
- (B) Air fuel ratio
- (C) Lean
- (D) Rich

#### 3. ENABLE CONDITION

Secondary Parameters	Enable Conditions
None	

#### 4. GENERAL DRIVING CYCLE

Always perform the diagnosis continuously.

#### 5. DIAGNOSTIC METHOD

##### • Abnormality Judgment

Judge NG when the malfunction criteria below are completed.

##### Judgment Value

Malfunction Criteria	Threshold Value
Continuous 6 times communication error to main CPU	≥ 2 sets

**Time Needed for Diagnosis:** Not determined

**Malfunction Indicator Light Illumination:** Illuminates as soon as malfunction occurs.

##### • Normality Judgment

Judge OK when the malfunction criteria below are completed.

##### Judgment Value

Malfunction Criteria	Threshold Value
Normal communication	2 times in a row

## Diagnostic Trouble Code (DTC) Detecting Criteria

GENERAL DESCRIPTION

### 6. DTC CLEAR CONDITION

- When the OK idling cycle was completed 40 times in a row
- When "Clear Memory" was performed

### 7. MALFUNCTION INDICATOR LIGHT CLEAR CONDITION

- When the OK driving cycle was completed 3 times in a row
- When "Clear Memory" was performed

### 8. FAIL SAFE

- A/F IC communication: Not allowed to communicate.
- A/F main learning compensation: Not allowed to calculate.
- Compensation at high temperature restart: Set min. value 0.3 → usually.
- Purge control: Not allowed to purge.

### 9. ECM OPERATION AT DTC SETTING

Memorize the freeze frame data. (For test mode \$02)

# Diagnostic Trouble Code (DTC) Detecting Criteria

## GENERAL DESCRIPTION

### DN:DTC P1152 O<sub>2</sub> SENSOR CIRCUIT RANGE/PERFORMANCE (LOW) (BANK1 SENSOR1)

#### 1. OUTLINE OF DIAGNOSIS

Detect that lambda value remains Low.

Judge NG when lambda value is abnormal in accordance with lambda value of front oxygen (A/F) sensor and running condition that is vehicle speed, amount of intake air engine coolant temperature, sub feedback control, etc.

**Lambda value = Actual air fuel ratio/Theoretical air fuel ratio**

Lambda > 1: Lean

Lambda < 1: Rich

#### 2. COMPONENT DESCRIPTION

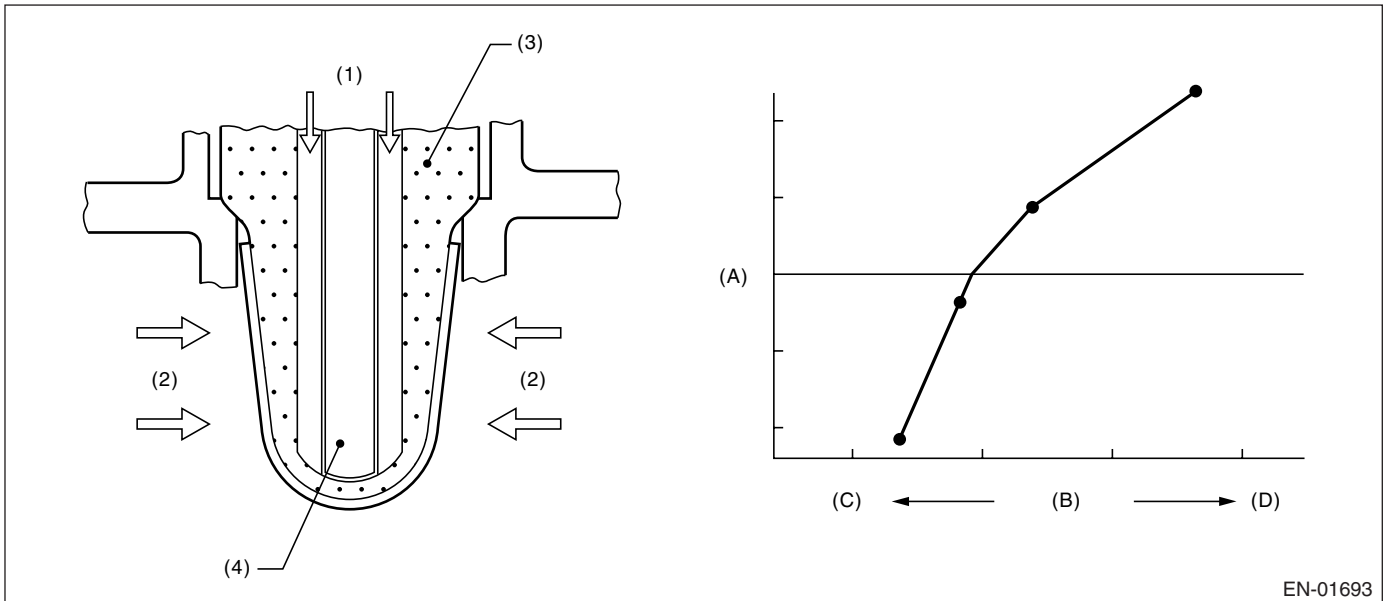

- (1) Atmosphere
- (2) Exhaust
- (3) ZrO<sub>2</sub>
- (4) Ceramic heater

- (A) Electromotive force
- (B) Air fuel ratio
- (C) Lean
- (D) Rich

EN-01693

# Diagnostic Trouble Code (DTC) Detecting Criteria

GENERAL DESCRIPTION

## 3. ENABLE CONDITION

Secondary Parameters	Enable Conditions
All secondary parameters to be in enable conditions	4 seconds or more
Battery voltage	> 10.9 V
Atmospheric pressure	> 75.1 kPa (563 mmHg, 22.2 inHg)
Rear oxygen sensor sub feedback	Operating
Rear oxygen sensor output voltage – feedback target voltage	–0.2 V ↔ 0.1 V
or rear oxygen sensor sub feedback compensation coefficient	On Min.
or rear oxygen sensor sub feedback compensation coefficient	On Max.
After engine starting	60 seconds or more
Engine coolant temperature	≥ 75°C (167°F)
Vehicle speed	≥ 20 km/h (12 MPH)
Amount of intake air	≥ 6 g/s
Load change during 0.5 engine rev.	≤ 0.01 g/rev
Impedance of front oxygen (A/F) sensor	0 ↔ 52 Ω
Learning value of evaporation gas density	≤ 0.2
Total time of operating canister purge	20 seconds or more

## 4. GENERAL DRIVING CYCLE

Perform diagnosis continuously at a constant speed of 20 km/h (12 MPH) or more since 60 seconds after starting the engine.

## 5. DIAGNOSTIC METHOD

Judge NG when the continuous time of completing the malfunction criteria below becomes more than the time needed for diagnosis (10 seconds). Judge OK and clear NG when the malfunction criteria below are not completed.

### Judgment Value

Malfunction Criteria	Threshold Value
Output lambda when rear oxygen sensor sub feedback compensation coefficient being at not high limit	≤ 0.85

**Time Needed for Diagnosis:** 10 seconds

**Malfunction Indicator Light Illumination:** Illuminates when malfunction occurs in 2 continuous driving cycles.

## 6. DTC CLEAR CONDITION

- When the OK idling cycle was completed 40 times in a row
- When “Clear Memory” was performed

## 7. MALFUNCTION INDICATOR LIGHT CLEAR CONDITION

- When the OK driving cycle was completed 3 times in a row
- When “Clear Memory” was performed

## 8. FAIL SAFE

- Front oxygen (A/F) sensor main learning correction: Not allowed to calculate
- Correction when re-starting at high temperature: Normally minimum value 0.3 → 0
- Purge control: Not allowed to purge



## Diagnostic Trouble Code (DTC) Detecting Criteria

GENERAL DESCRIPTION

---

### 9. ECM OPERATION AT DTC SETTING

Memorize the freeze frame data. (For test mode \$02)

# Diagnostic Trouble Code (DTC) Detecting Criteria

GENERAL DESCRIPTION

## DO:DTC P1153 O<sub>2</sub> SENSOR CIRCUIT RANGE/PERFORMANCE (HIGH) (BANK1 SENSOR1)

### 1. OUTLINE OF DIAGNOSIS

Detect that lambda value remains High.

Judge NG when lambda value is abnormal in accordance with lambda value of front oxygen (A/F) sensor and running condition that is vehicle speed, amount of intake air engine coolant temperature, sub feedback control, etc.

**Lambda value = Actual air fuel ratio/Theoretical air fuel ratio**

Lambda > 1: Lean

Lambda < 1: Rich

### 2. COMPONENT DESCRIPTION

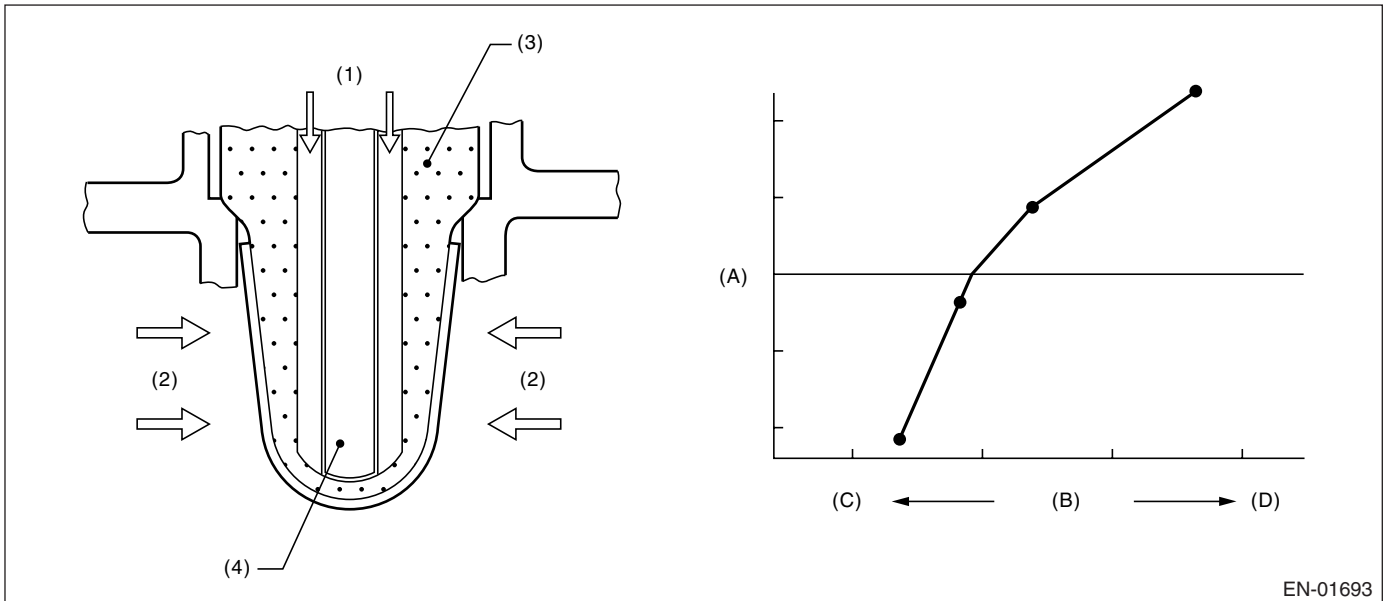

- (1) Atmosphere
- (2) Exhaust
- (3) ZrO<sub>2</sub>
- (4) Ceramic heater

- (A) Electromotive force
- (B) Air fuel ratio
- (C) Lean
- (D) Rich

EN-01693

# Diagnostic Trouble Code (DTC) Detecting Criteria

## GENERAL DESCRIPTION

### 3. ENABLE CONDITION

Secondary Parameters	Enable Conditions
All secondary parameters to be in enable conditions	4 seconds or more
Battery voltage	> 10.9 V
Atmospheric pressure	> 75.1 kPa (563 mmHg, 22.2 inHg)
Rear oxygen sensor sub feedback	Operating
Rear oxygen sensor output voltage – feedback target voltage	–0.2 V ↔ 0.1 V
or rear oxygen sensor sub feedback compensation coefficient	On Min.
or rear oxygen sensor sub feedback compensation coefficient	On Max.
After engine starting	60 seconds or more
Engine coolant temperature	≥ 75°C (167°F)
Vehicle speed	≥ 20 km/h (12 MPH)
Amount of intake air	≥ 6 g/s
Load change during 0.5 engine rev.	≤ 0.01 g/rev
Impedance of front oxygen (A/F) sensor	0 ↔ 52 Ω
Learning value of evaporation gas density	≤ 0.2
Total time of operating canister purge	20 seconds or more

### 4. GENERAL DRIVING CYCLE

Perform diagnosis continuously at a constant speed of 20 km/h (12 MPH) or more since 60 seconds after starting the engine.

### 5. DIAGNOSTIC METHOD

Judge NG when the continuous time of completing the malfunction criteria below becomes more than the time needed for diagnosis (10 seconds). Judge OK and clear NG when the malfunction criteria below are not completed.

#### Judgment Value

Malfunction Criteria	Threshold Value
Output lambda when rear O <sub>2</sub> sensor sub feedback compensation coefficient value being at not low limit	≥ 1.15

**Time Needed for Diagnosis:** 10 seconds

**Malfunction Indicator Light Illumination:** Illuminates when malfunction occurs in 2 continuous driving cycles.

### 6. DTC CLEAR CONDITION

- When the OK idling cycle was completed 40 times in a row
- When “Clear Memory” was performed

### 7. MALFUNCTION INDICATOR LIGHT CLEAR CONDITION

- When the OK driving cycle was completed 3 times in a row
- When “Clear Memory” was performed

### 8. FAIL SAFE

- Front oxygen (A/F) sensor main learning correction: Not allowed to calculate
- Correction when re-starting at high temperature: Normally minimum value 0.3 → 0
- Purge control: Not allowed to purge

## Diagnostic Trouble Code (DTC) Detecting Criteria

GENERAL DESCRIPTION

### 9. ECM OPERATION AT DTC SETTING

Memorize the freeze frame data. (For test mode \$02)

# Diagnostic Trouble Code (DTC) Detecting Criteria

## GENERAL DESCRIPTION

### DP:DTC P1301 MISFIRE DETECTED (HIGH TEMPERATURE EXHAUST GAS)

#### 1. OUTLINE OF DIAGNOSIS

Detect whether the misfire occurred or not. (Exhaust temperature method)  
Judge NG when the exhaust temperature is high.

#### 2. ENABLE CONDITION

Secondary Parameters	Enable Conditions
Ignition SW	ON
Battery voltage	≥ 10.9 V
Atmosphere	≥ 75.1 kPa (563 mmHg, 22.2 inHg)
Starter	OFF

#### 3. GENERAL DRIVING CYCLE

Always perform the diagnosis continuously.

#### 4. DIAGNOSTIC METHOD

Judge NG when the malfunction criteria below continue 200 engine revs. (400 ignitions) in a row.

##### Judgment Value

Malfunction Criteria	Threshold Value
Amount of intake air	< 60 g/s
Exhaust temperature	> 1,050°C (1,922°F)

**Time Needed for Diagnosis:** 200 engine revs.

**Malfunction Indicator Light Illumination:** Illuminates as soon as malfunction occurs.

#### 5. DTC CLEAR CONDITION

- When the OK idling cycle was completed 40 times in a row
- When "Clear Memory" was performed

#### 6. MALFUNCTION INDICATOR LIGHT CLEAR CONDITION

- When the OK driving cycle was completed 3 times in a row
- When "Clear Memory" was performed

#### 7. FAIL SAFE

None

#### 8. ECM OPERATION AT DTC SETTING

Memorize the freeze frame data. (For test mode \$02)

# Diagnostic Trouble Code (DTC) Detecting Criteria

GENERAL DESCRIPTION

## DQ:DTC P1312 EXHAUST GAS TEMPERATURE SENSOR MALFUNCTION

### 1. OUTLINE OF DIAGNOSIS

Detect the malfunction of exhaust temperature sensor output property.

Judge NG when the exhaust temperature remains high or low whereas it seemed to vary from the viewpoint of driving condition.

### 2. ENABLE CONDITION

Secondary Parameters	Enable Conditions
After engine starting	240 seconds or more
Engine coolant temperature at engine start	$\leq 40^{\circ}\text{C}$ ( $104^{\circ}\text{F}$ )
Engine coolant temperature	$\geq 75^{\circ}\text{C}$ ( $167^{\circ}\text{F}$ )
Intake air temperature at engine start	$\geq 0^{\circ}\text{C}$ ( $32^{\circ}\text{F}$ )
Estimate ambient temperature	$\geq 0^{\circ}\text{C}$ ( $32^{\circ}\text{F}$ )
Vehicle speed	$\geq 65$ km/h (40 MPH)
Engine speed	$\geq 2,400$ rpm
Engine load	$\geq 0.85$ g/rev
Lambda value	0.75 $\longleftrightarrow$ 1.25

### 3. GENERAL DRIVING CYCLE

Perform the diagnosis continuously at more than 65 km/h (40 MPH) in 240 seconds and more after starting the engine in cool condition.

Pay attention to the coolant temperature at engine starting.

### 4. DIAGNOSTIC METHOD

Judge NG when one of the malfunction criteria below is completed, and judge OK and clear the NG when all of the malfunction criteria below are not completed.

#### Judgment Value

Malfunction Criteria	Threshold Value
Min. exhaust temperature from engine starting	$\geq 700^{\circ}\text{C}$ ( $1,292^{\circ}\text{F}$ )
Max. exhaust temperature from engine starting	$< 500^{\circ}\text{C}$ ( $932^{\circ}\text{F}$ )

**Time Needed for Diagnosis:** 0 seconds

**Malfunction Indicator Light Illumination:** Illuminates as soon as malfunction occurs.

### 5. DTC CLEAR CONDITION

- When the OK idling cycle was completed 40 times in a row
- When "Clear Memory" was performed

### 6. MALFUNCTION INDICATOR LIGHT CLEAR CONDITION

- When the OK driving cycle was completed 3 times in a row
- When "Clear Memory" was performed

### 7. FAIL SAFE

None

### 8. ECM OPERATION AT DTC SETTING

Memorize the freeze frame data. (For test mode \$02)

# Diagnostic Trouble Code (DTC) Detecting Criteria

## GENERAL DESCRIPTION

### DR:DTC P1400 FUEL TANK PRESSURE CONTROL SOLENOID VALVE CIRCUIT LOW

#### 1. OUTLINE OF DIAGNOSIS

Detect open or short circuit of pressure control solenoid valve. Judge NG when ECM output level is different from actual terminal level.

#### 2. COMPONENT DESCRIPTION

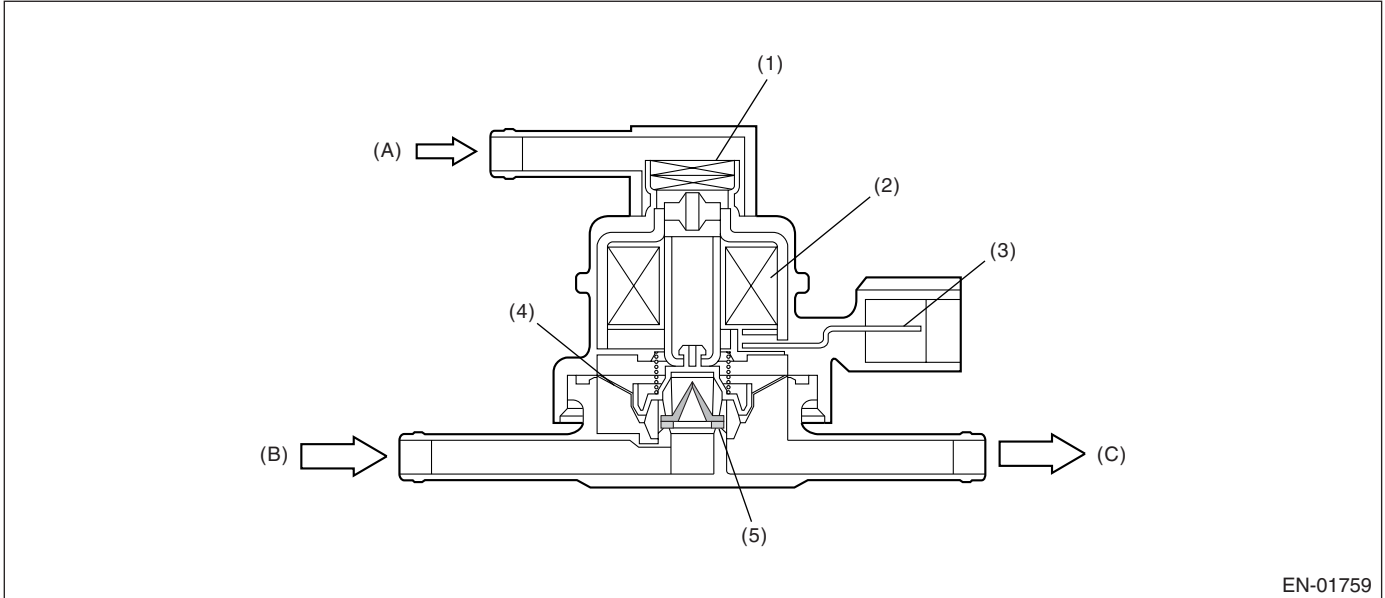

- (1) Filter
- (2) Coil
- (3) Connector terminal
- (4) Diaphragm
- (5) Valve

- (A) Atmospheric pressure
- (B) Shut off valve
- (C) To fuel tank

#### 3. ENABLE CONDITION

Secondary Parameters	Enable Conditions
Ignition switch	ON
Battery voltage	$\geq 10.9 \text{ V}$
After engine starting	1 second or more

#### 4. GENERAL DRIVING CYCLE

Always perform the diagnosis after starting the engine.

#### 5. DIAGNOSTIC METHOD

Judge NG when the continuous time of completing the malfunction criteria below becomes more than time needed for diagnosis (2.5 seconds). Judge OK and clear the NG when the malfunction criteria below are not completed.

##### Judgment Value

Malfunction Criteria	Threshold Value
Terminal voltage when ECM outputs off signal	Low

**Time Needed for Diagnosis:** 2.5 seconds

**Malfunction Indicator Light Illumination:** Illuminates when malfunction occurs in two continuous drive cycles.

## Diagnostic Trouble Code (DTC) Detecting Criteria

GENERAL DESCRIPTION

### 6. DTC CLEAR CONDITION

- When the OK idling cycle was completed 40 times in a row
- When "Clear Memory" was performed

### 7. MALFUNCTION INDICATOR LIGHT CLEAR CONDITION

- When the OK driving cycle was completed 3 times in a row
- When "Clear Memory" was performed

### 8. FAIL SAFE

None

### 9. ECM OPERATING AT DTC SETTING

Memorize the freeze frame data. (For test mode \$02)



# Diagnostic Trouble Code (DTC) Detecting Criteria

## GENERAL DESCRIPTION

### DS:DTC P1420 FUEL TANK PRESSURE CONTROL SOL. VALVE CIRCUIT HIGH

#### 1. OUTLINE OF DIAGNOSIS

Detect open or short circuit of pressure control solenoid valve.  
Judge NG when ECM output level is different from actual terminal level.

#### 2. COMPONENT DESCRIPTION

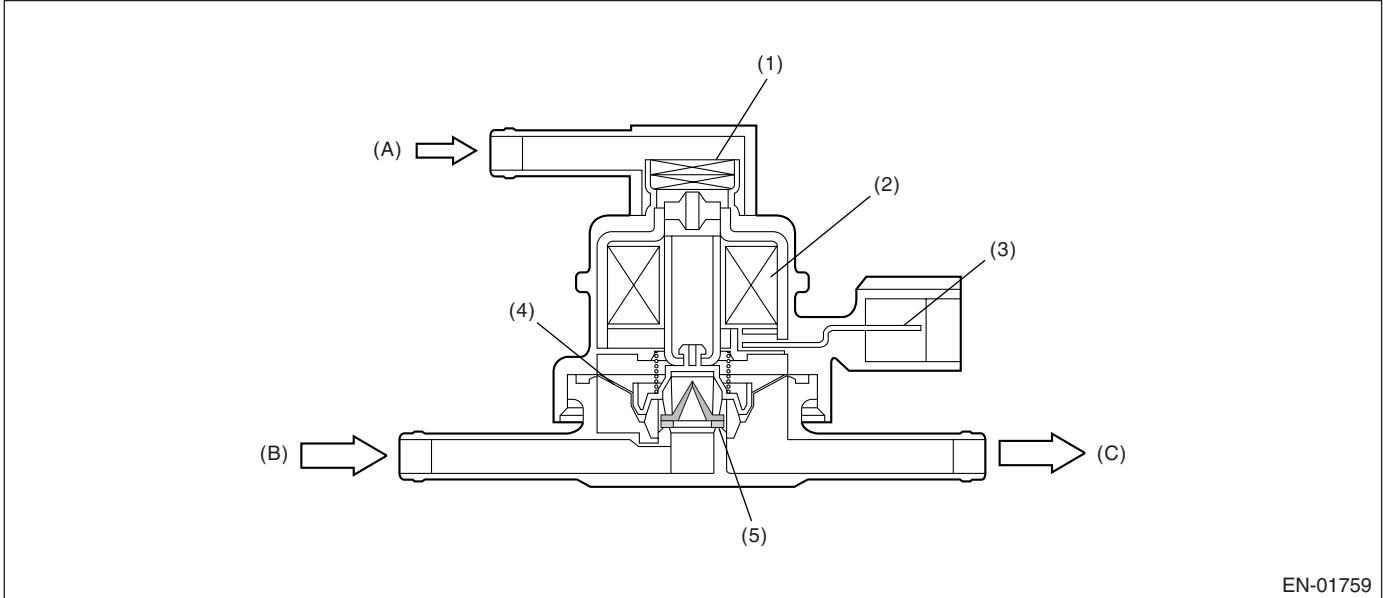

- (1) Filter
- (2) Coil
- (3) Connector terminal
- (4) Diaphragm
- (5) Valve
- (A) Atmospheric pressure
- (B) Shut off valve
- (C) To fuel tank

#### 3. ENABLE CONDITION

Secondary Parameters	Enable Conditions
Ignition switch	ON
Battery voltage	$\geq 10.9 \text{ V}$
After engine starting	1 second or more

#### 4. GENERAL DRIVING CYCLE

Always perform the diagnosis after starting the engine.

#### 5. DIAGNOSTIC METHOD

Judge NG when the continuous time of completing the malfunction criteria below becomes more than time needed for diagnosis (2.5 seconds). Judge OK and clear the NG when the malfunction criteria below are not completed.

##### Judgment Value

Malfunction Criteria	Threshold Value
Terminal voltage when ECM outputs off signal	High

**Time Needed for Diagnosis:** 2.5 seconds

**Malfunction Indicator Light Illumination:** Illuminates when malfunction occurs in two continuous drive cycles.

## Diagnostic Trouble Code (DTC) Detecting Criteria

GENERAL DESCRIPTION

### 6. DTC CLEAR CONDITION

- When the OK idling cycle was completed 40 times in a row
- When "Clear Memory" was performed

### 7. MALFUNCTION INDICATOR LIGHT CLEAR CONDITION

- When the OK driving cycle was completed 3 times in a row
- When "Clear Memory" was performed

### 8. FAIL SAFE

None

### 9. ECM OPERATING AT DTC SETTING

Memorize the freeze frame data. (For test mode \$02)

## DT:DTC P1443 VENT CONTROL SOLENOID VALVE FUNCTION PROBLEM

### 1. OUTLINE OF DIAGNOSIS

For detecting conditions, refer to DTC P0442 EVAPORATIVE EMISSION CONTROL SYSTEM LEAK DETECTED (SMALL LEAK). <Ref. to GD(H4DOTC)-112, DTC P0442 EVAPORATIVE EMISSION CONTROL SYSTEM LEAK DETECTED (SMALL LEAK), Diagnostic Trouble Code (DTC) Detecting Criteria.>

# Diagnostic Trouble Code (DTC) Detecting Criteria

## GENERAL DESCRIPTION

### DU:DTC P1446 FUEL TANK SENSOR CONTROL VALVE CIRCUIT LOW

#### 1. OUTLINE OF DIAGNOSIS

Detect the open or short circuit of tank pressure switching solenoid.  
Judge NG when the ECM output level is different from actual terminal level.

#### 2. COMPONENT DESCRIPTION

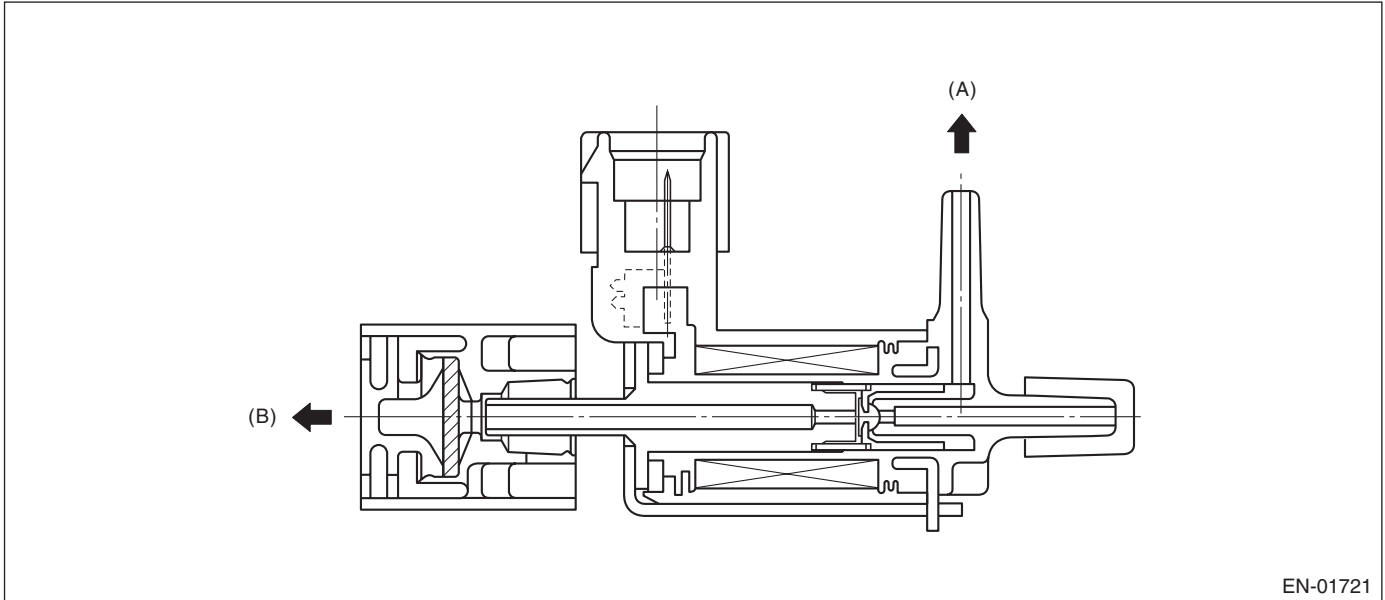

(A) Fuel tank pressure sensor

(B) Ambient air

#### 3. ENABLE CONDITION

Secondary Parameters	Enable Conditions
None	

#### 4. GENERAL DRIVING CYCLE

Always perform the diagnosis continuously.

#### 5. DIAGNOSTIC METHOD

##### • Abnormality Judgment

Judge NG when the continuous time of completing the malfunction criteria below becomes more than 2.5 seconds.

##### Judgment Value

Malfunction Criteria	Threshold Value
Battery voltage	$\geq 10.9 \text{ V}$
After engine starting	1 second or more
Terminal output voltage when ECM sent OFF signals	Low

**Time Needed for Diagnosis:** 2.5 seconds

**Malfunction Indicator Light Illumination:** Illuminates when malfunction occurs in 2 continuous driving cycles.

# Diagnostic Trouble Code (DTC) Detecting Criteria

GENERAL DESCRIPTION

## • Normality Judgment

Judge OK when the malfunction criteria below are completed.

### Judgment Value

Malfunction Criteria	Threshold Value
Battery voltage	$\geq 10.9$ V
After engine starting	1 second or more
Terminal output voltage when ECM sent OFF signals	High

## 6. DTC CLEAR CONDITION

- When the OK idling cycle is completed 40 times in a row
- When "Clear Memory" was performed

## 7. MALFUNCTION INDICATOR LIGHT CLEAR CONDITION

- When the OK driving cycle is completed 3 times in a row
- When "Clear Memory" was performed

## 8. FAIL SAFE

None

## 9. ECM OPERATION AT DTC SETTING

Memorize the freeze frame data. (For test mode \$02)

# Diagnostic Trouble Code (DTC) Detecting Criteria

## GENERAL DESCRIPTION

### DV:DTC P1447 FUEL TANK SENSOR CONTROL VALVE CIRCUIT HIGH

#### 1. OUTLINE OF DIAGNOSIS

Detect the open or short circuit of tank pressure switching solenoid.  
Judge NG when the ECM output level is different from actual terminal level.

#### 2. COMPONENT DESCRIPTION

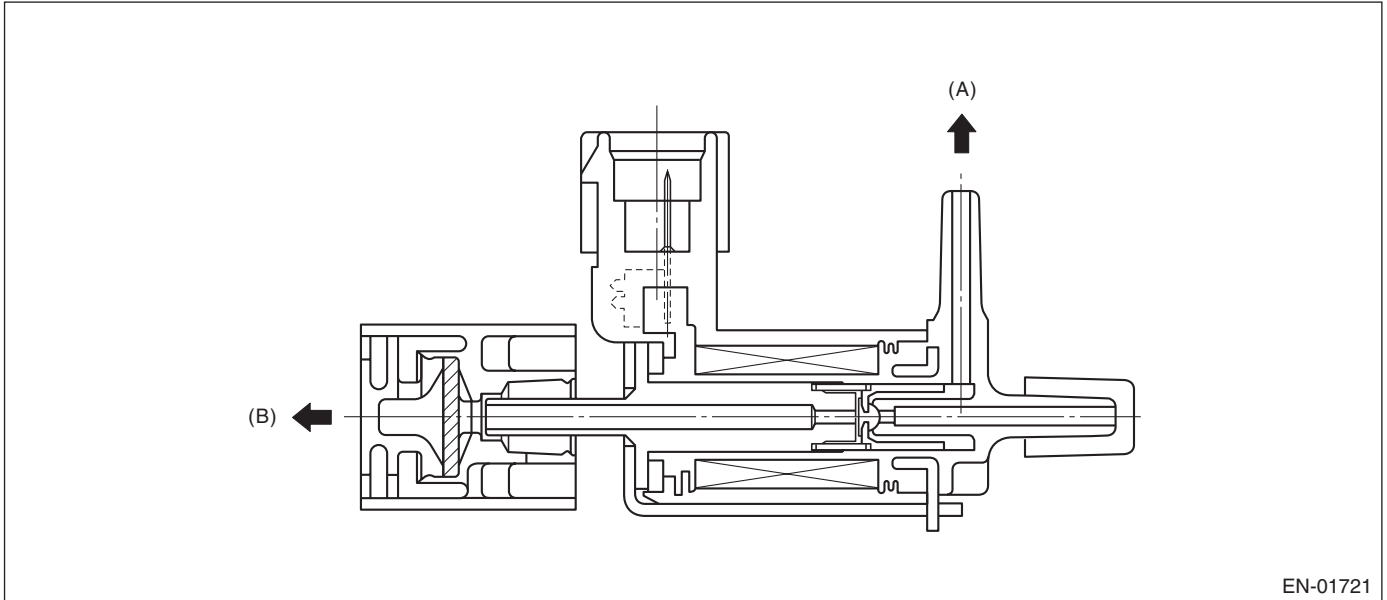

(A) Fuel tank pressure sensor

(B) Ambient air

#### 3. ENABLE CONDITION

Secondary Parameters	Enable Conditions
None	

#### 4. GENERAL DRIVING CYCLE

Always perform the diagnosis continuously.

#### 5. DIAGNOSTIC METHOD

##### • Abnormality Judgment

Judge NG when the cumulative time of completing the malfunction criteria below becomes more than 2.5 seconds.

##### Judgment Value

Malfunction Criteria	Threshold Value
Battery voltage	$\geq 10.9$ V
After engine starting	1 second or more
Terminal output voltage when ECM sent ON signals	High

**Time Needed for Diagnosis:** 2.5 seconds

**Malfunction Indicator Light Illumination:** Illuminates when malfunction occurs in two continuous drive cycles.

# Diagnostic Trouble Code (DTC) Detecting Criteria

GENERAL DESCRIPTION

## • Normality Judgment

Judge OK when the malfunction criteria below are completed.

### Judgment Value

Malfunction Criteria	Threshold Value
Battery voltage	$\geq 10.9$ V
After engine starting	1 second or more
Terminal output voltage when ECM sent OFF signals	Low

## 6. DTC CLEAR CONDITION

- When the OK idling cycle is completed 40 times in a row
- When "Clear Memory" was performed

## 7. MALFUNCTION INDICATOR LIGHT CLEAR CONDITION

- When the OK driving cycle is completed 3 times in a row
- When "Clear Memory" was performed

## 8. FAIL SAFE

None

## 9. ECM OPERATION AT DTC SETTING

Memorize the freeze frame data. (For test mode \$02)

# Diagnostic Trouble Code (DTC) Detecting Criteria

## GENERAL DESCRIPTION

### DW:DTC P1448 FUEL TANK SENSOR CONTROL VALVE RANGE PERFORMANCE

#### 1. OUTLINE OF DIAGNOSIS

Detect the tank pressure switching solenoid function abnormality.

The tank pressure sensor is a relative pressure sensor, which normally compares the pressure with the atmospheric pressure. The tank pressure switching solenoid is a solenoid, which shifts the compare space from opening to closed during the EVAP diagnosis. Detect the malfunction that the compare space remains closed. (Not judge NG after enable condition completed but assume NG before enable condition completed.)

#### • Normality Judgment

Judge OK when the fuel tank pressure does not change (or changes by less than 0.67 kPa (5 mmHg, 0.2 inHg) at atmospheric pressure changing by 0.67 kPa (5 mmHg, 0.2 inHg) or more per 80 seconds.

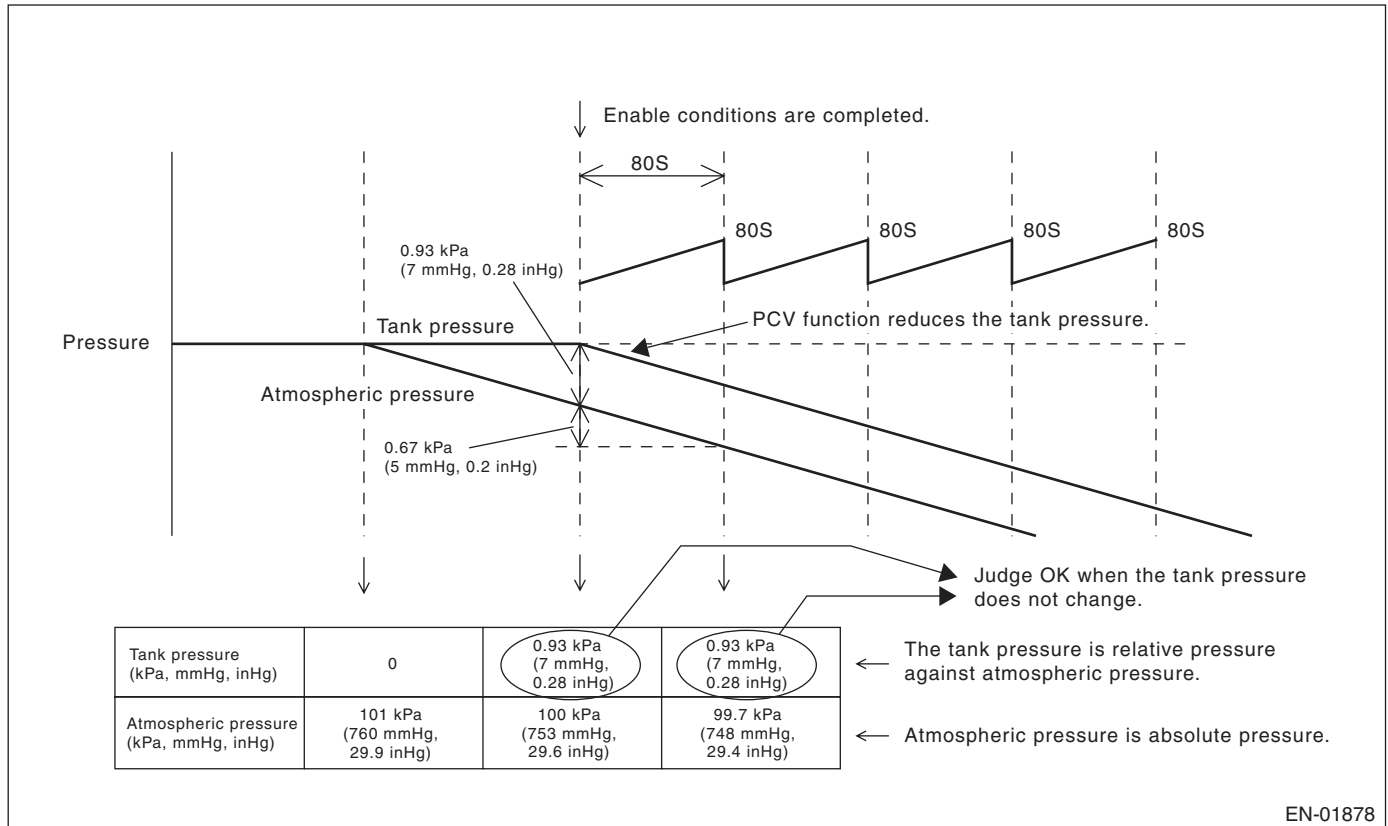

# Diagnostic Trouble Code (DTC) Detecting Criteria

GENERAL DESCRIPTION

## • Abnormality Judgment

Judge NG temporarily when the fuel tank pressure changes by 0.67 kPa (5 mmHg, 0.2 inHg) or more at atmospheric pressure changing by 0.67 kPa (5 mmHg, 0.2 inHg) or more per 80 seconds, and then judge NG when the previous condition is completed 5 times in a row.

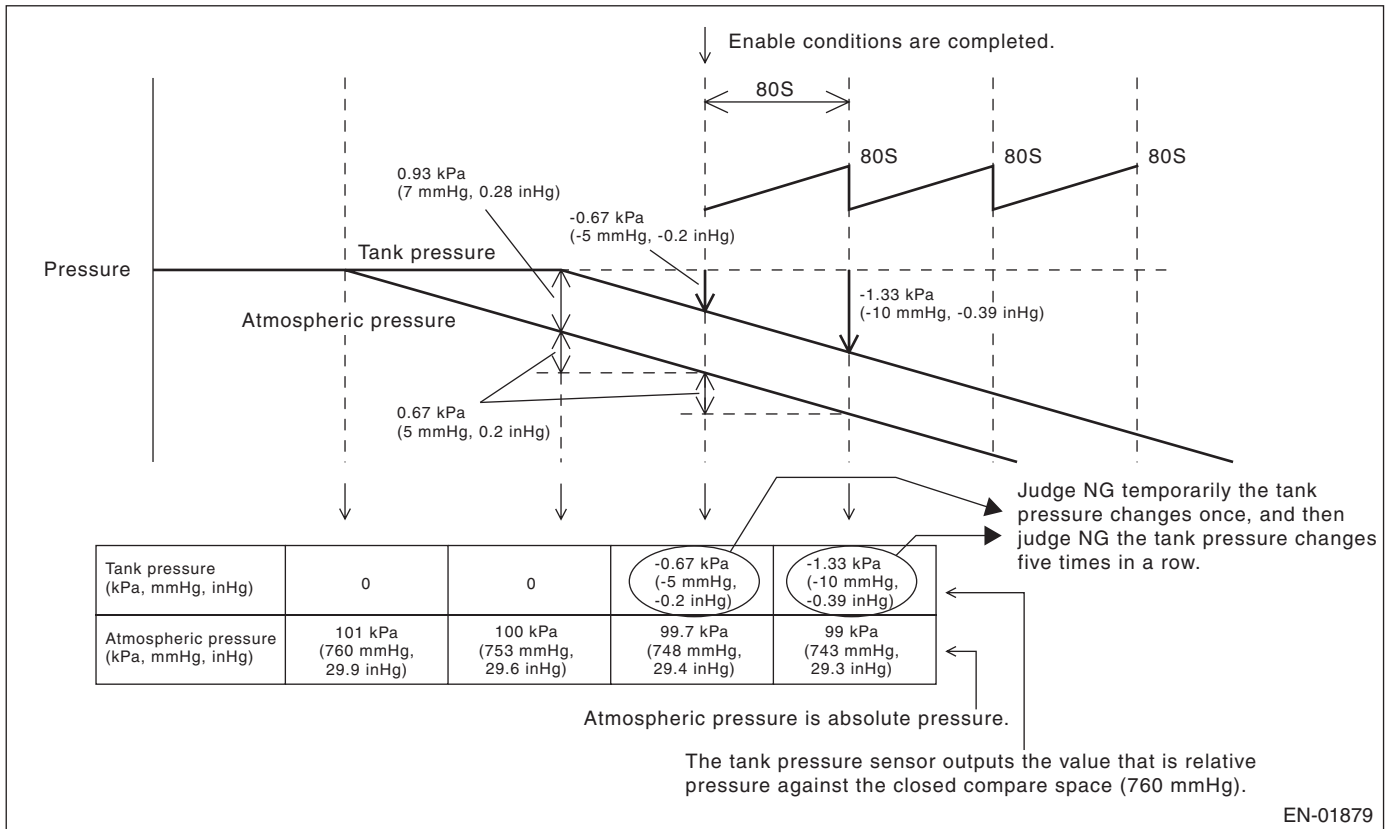

## 2. COMPONENT DESCRIPTION

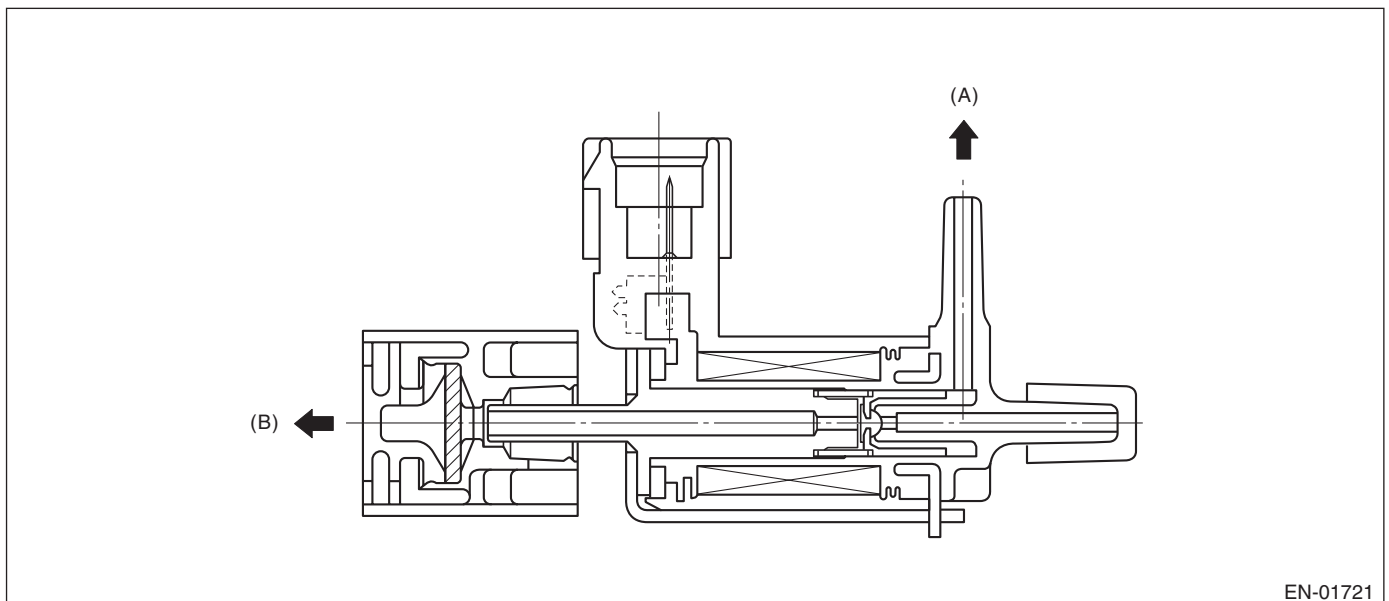

- (A) Fuel tank pressure sensor
- (B) Ambient air



# Diagnostic Trouble Code (DTC) Detecting Criteria

## GENERAL DESCRIPTION

### 3. ENABLE CONDITION

Secondary Parameter	Enable Condition
Battery voltage	$\geq 10.9$ V
Fuel level	9 $\leftrightarrow$ 51 $\ell$ (2.38 $\leftrightarrow$ 13.3 US gal, 1.98 $\leftrightarrow$ 11.2 Imp gal)
Evaporation system diagnosis	Not in operation
After starting the engine	80 seconds or more
Fuel tank pressure	$< -0.67$ kPa ( $-5$ mmHg, $-0.2$ inHg) or $> -0.93$ kPa (7 mmHg, 0.28 inHg)

### 4. GENERAL DRIVING CYCLE

Perform the diagnosis continuously when the fuel tank pressure is large or small in 80 seconds or more after starting the engine.

### 5. DIAGNOSTIC METHOD

#### • Abnormality Judgment

Judge NG when the malfunction criteria below is completed 5 times.

#### Judgment Value

Malfunction Criteria	Threshold Value
Atmospheric air change in 80 seconds	$\geq 0.67$ kPa (5 mmHg, 0.2 inHg)
Fuel tank pressure change in 80 seconds	$\geq 0.67$ kPa (5 mmHg, 0.2 inHg)
Fuel level change	$< 3$ $\ell$ (0.79 US gal, 0.7 Imp gal)

**Time Needed for Diagnosis:** 80 seconds  $\times$  5 times

**Malfunction Indicator Light Illumination:** Illuminates when malfunction occurs in 2 continuous driving cycles.

#### • Normality Judgment

Judge OK and clear NG when the malfunction criteria below is completed.

#### Judgment Value

Malfunction Criteria	Threshold Value
Atmospheric air change in 80 seconds	$\geq 0.67$ kPa (5 mmHg, 0.2 inHg)
Fuel tank pressure change in 80 seconds	$< 0.67$ kPa (5 mmHg, 0.2 inHg)

### 6. DTC CLEAR CONDITION

- When the OK idling cycle was completed 40 times in a row
- When "Clear Memory" was performed

### 7. MALFUNCTION INDICATOR LIGHT CLEAR CONDITION

- When the OK driving cycle was completed 3 times in a row
- When "Clear Memory" was performed

### 8. FAIL SAFE

None

### 9. ECM OPERATION AT DTC SETTING

Memorize the freeze frame data. (For test mode \$02)

# Diagnostic Trouble Code (DTC) Detecting Criteria

GENERAL DESCRIPTION

## DX:DTC P1491 POSITIVE CRANKCASE VENTILATION (BLOW-BY) FUNCTION PROBLEM

### 1. OUTLINE OF DIAGNOSIS

Detect the blow-by hose release abnormality.  
Judge NG when the diagnosis terminal voltage is high.

### 2. COMPONENT DESCRIPTION

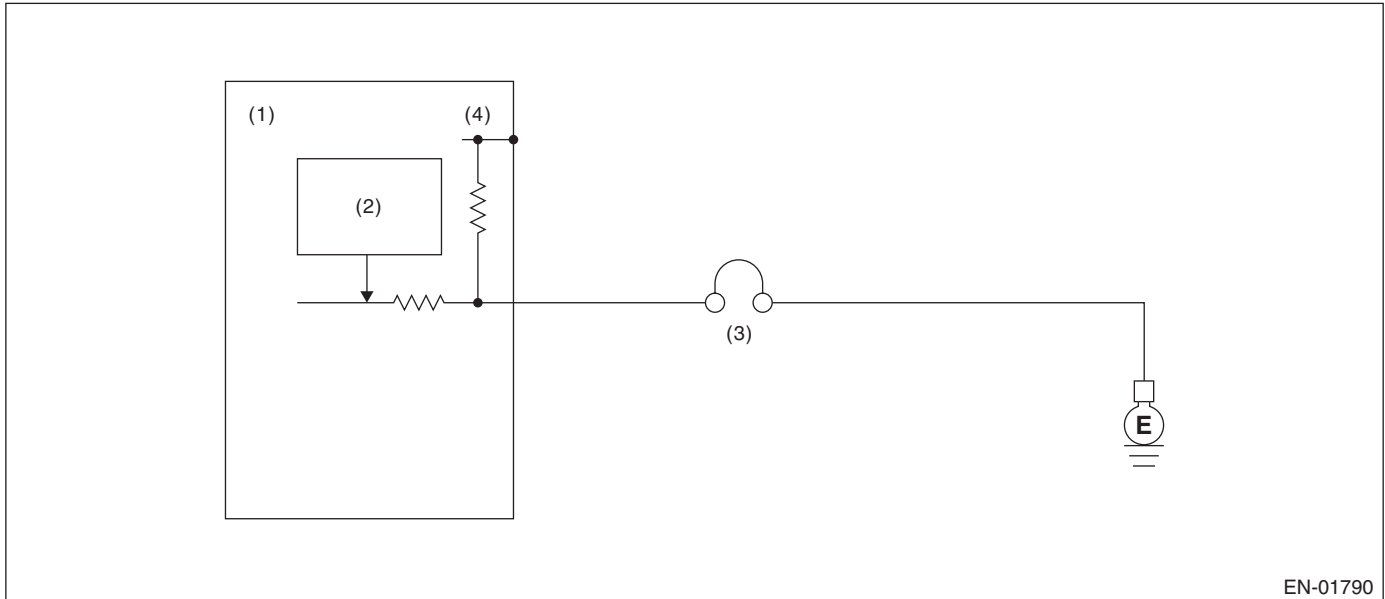

- (1) Engine control module (ECM)
- (2) Detecting circuit
- (3) PCV diagnosis connector
- (4) 5 V

### 3. ENABLE CONDITION

Secondary Parameter	Enable Condition
None	

### 4. GENERAL DRIVING CYCLE

Always perform the diagnosis continuously.

### 5. DIAGNOSIS METHOD

#### • Abnormality Judgment

Judge NG when the continuous time until completing the malfunction criteria below becomes more than 1 second.

#### Judgment Value

Malfunction Criteria	Threshold Value
Battery voltage	> 10.9 V
Before and after starting the engine	After starting the engine
Positive crankcase ventilation diagnosis voltage	High

**Time Needed for Diagnosis:** 1 second

**Malfunction Indicator Light Illumination:** Illuminates as soon as malfunction occurs.

# Diagnostic Trouble Code (DTC) Detecting Criteria

## GENERAL DESCRIPTION

### • Normality Judgment

Judge OK and clear NG when the malfunction criteria below is completed.

### Judgment Value

Malfunction Criteria	Threshold Value
Battery voltage	> 10.9 V
Before and after starting the engine	After starting the engine
Positive crankcase ventilation diagnosis voltage	Low

### 6. DTC CLEAR CONDITION

- When the OK idling cycle was completed 40 times in a row
- When "Clear Memory" was performed

### 7. MALFUNCTION INDICATOR LIGHT CLEAR CONDITION

- When the OK driving cycle was performed 3 times in a row
- When "Clear Memory" was performed

### 8. FAIL SAFE

None

### 9. ECM OPERATION AT DTC SETTING

- Memorize the freeze frame data. (For test mode \$02)
- Memorize the diagnosis value and trouble standard value. (For test mode \$06)

# Diagnostic Trouble Code (DTC) Detecting Criteria

GENERAL DESCRIPTION

## DY:DTC P1518 STARTER SWITCH CIRCUIT LOW INPUT

### 1. OUTLINE OF DIAGNOSIS

Detect the open or short circuit of starter SW.

Judge OFF NG when the engine starts without starter SW signal.

### 2. ENABLE CONDITION

Secondary Parameters	Enable Conditions
None	

### 3. GENERAL DRIVING CYCLE

Always perform the diagnosis continuously.

### 4. DIAGNOSTIC METHOD

#### • Abnormality Judgment

Judge OFF NG when the malfunction criteria below are completed.

#### Judgment Value

Malfunction Criteria	Threshold Value
Vehicle speed It took more than 0.8 seconds at engine starting, and then it turned after engine starting.	< 1 km/h (0.62 MPH)
Starter ON	Not experienced
Starter ON diagnosis	Not diagnosed
Battery voltage	> 8 V

**Time Needed for Diagnosis:** Not determined.

**Malfunction Indicator Light Illumination:** Illuminates when malfunction occurs in 2 continuous driving cycles.

#### • Normality Judgment

Judge OFF OK and clear the NG when the malfunction criteria below are completed.

#### Judgment Value

Malfunction Criteria	Threshold Value
Starter ON	Experienced
Starter ON diagnosis	Diagnosed
Battery voltage	> 8 V

### 5. DTC CLEAR CONDITION

- When the OK idling cycle was completed 40 times in a row
- When "Clear Memory" was performed

### 6. MALFUNCTION INDICATOR LIGHT CLEAR CONDITION

- When the OK driving cycle was completed 3 times in a row
- When "Clear Memory" was performed

### 7. FAIL SAFE

None

### 8. ECM OPERATION AT DTC SETTING

Memorize the freeze frame data. (For test mode \$02)

# Diagnostic Trouble Code (DTC) Detecting Criteria

## GENERAL DESCRIPTION

### DZ:DTC P1544 EXHAUST GAS TEMPERATURE TOO HIGH

#### 1. OUTLINE OF DIAGNOSIS

Detect the malfunction of high exhaust gas temperature.  
Judge NG when the exhaust gas becomes too high.

#### 2. ENABLE CONDITION

Secondary Parameters	Enable Conditions
Battery voltage	> 10.9 V

#### 3. GENERAL DRIVING CYCLE

Always perform the diagnosis continuously.

#### 4. DIAGNOSTIC METHOD

##### • Abnormality Judgment

Judge NG when the continuous time of completing the malfunction criteria below becomes more than 8.2 seconds.

##### Judgment Value

Malfunction Criteria	Threshold Value
Fuel cut event	Not operating
After fuel cut	≥ 1 milliseconds
Exhaust temperature	≥ 1,050°C (1,922°F)

**Time Needed for Diagnosis:** 8.2 seconds

**Malfunction Indicator Light Illumination:** Illuminates as soon as the malfunction occurs.

##### • Normality Judgment

Judge OK and clear the NG when the continuous time of completing the malfunction criteria below becomes more than 8.2 seconds.

##### Judgment Value

Malfunction Criteria	Threshold Value
Exhaust temperature	< 550°C (1,022°F)

#### 5. DTC CLEAR CONDITION

- When the OK idling cycle was completed 40 times in a row
- When "Clear Memory" was performed

#### 6. MALFUNCTION INDICATOR LIGHT CLEAR CONDITION

- When the OK driving cycle was completed 3 times in a row
- When "Clear Memory" was performed

#### 7. FAIL SAFE

None

#### 8. ECM OPERATION AT DTC SETTING

Memorize the freeze frame data. (For test mode \$02)

# Diagnostic Trouble Code (DTC) Detecting Criteria

GENERAL DESCRIPTION

## EA:DTC P1560 BACK-UP VOLTAGE CIRCUIT MALFUNCTION

### 1. OUTLINE OF DIAGNOSIS

Detect open or short circuit of the back-up voltage circuit.

Judge NG when the back-up voltage becomes smaller than the battery voltage.

### 2. ENABLE CONDITION

Secondary Parameter	Enable Condition
None	

### 3. GENERAL DRIVING CYCLE

Always perform the diagnosis continuously.

### 4. DIAGNOSTIC METHOD

#### • Abnormality Judgment

Judge NG when the continuous time of completing the malfunction criteria below becomes more than 2.5 seconds.

#### Judgment Value

Malfunction Criteria	Threshold Value
Voltage of back-up power	$< \text{Battery voltage} \times 0.7$
Battery voltage	$\geq 10.9 \text{ V}$
Before and after starting the engine	After starting the engine

**Time Needed for Diagnosis:** 2.5 seconds

**Malfunction Indicator Light Illumination:** Illuminates as soon as malfunction occurs.

#### • Normality Judgment

Judge OK and clear NG when the malfunction criteria below is completed.

#### Judgment Value

Malfunction Criteria	Threshold Value
Voltage of back-up power supply	$\geq \text{Battery voltage} \times 0.7$
Battery voltage	$\geq 10.9 \text{ V}$
Before and after starting the engine	After starting the engine

### 5. DTC CLEAR CONDITION

- When the OK idling cycle was completed 40 times in a row
- When "Clear Memory" was performed

### 6. MALFUNCTION INDICATOR LIGHT CLEAR CONDITION

- When the OK driving cycle was completed 3 times in a row
- When "Clear Memory" was performed

### 7. FAIL SAFE

None

### 8. ECM OPERATION AT DTC SETTING

Memorize the freeze frame data. (For test mode \$02)

# Diagnostic Trouble Code (DTC) Detecting Criteria

## GENERAL DESCRIPTION

### EB:DTC P1700 THROTTLE POSITION SENSOR CIRCUIT MALFUNCTION FOR AT

#### 1. OUTLINE OF DIAGNOSIS

Judge NG when the voltage from throttle sensor is out of specified value.

#### 2. COMPONENT DESCRIPTION

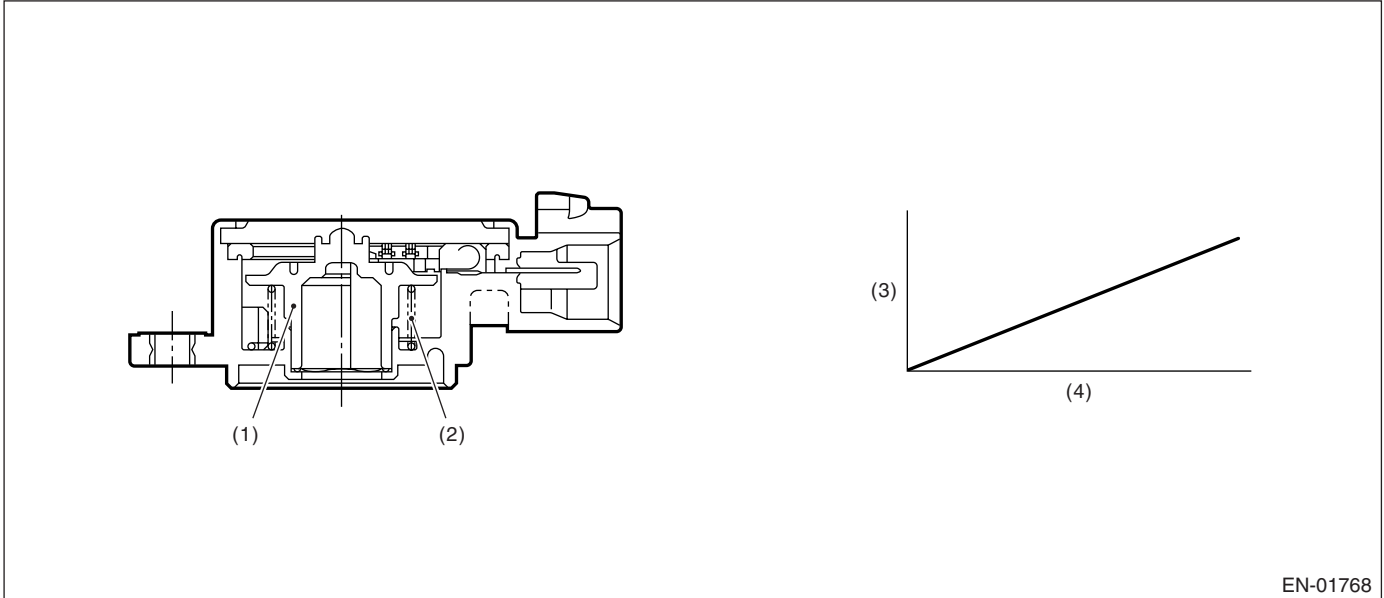

- (1) Rotor
- (2) Return spring
- (3) Voltage (V)
- (4) Throttle valve angle (°)

#### 3. ENABLE CONDITION

Secondary Parameters	Enable Conditions
None	

#### 4. GENERAL DRIVING CYCLE

Always perform the diagnosis.

#### 5. DIAGNOSTIC METHOD

##### Judgment Value

Malfunction Criteria	Threshold Value
Output voltage	$\leq 0.1$ or $\geq 4.6$ V

**Time Needed for Diagnosis:** 63.75 seconds

**Malfunction Indicator Light Illumination:** Detect when malfunction occurs in two continuous driving cycles.

#### 6. DTC CLEAR CONDITION

- When the OK idling cycle was completed 40 times in a row
- When "Clear Memory" was performed

#### 7. MALFUNCTION INDICATOR LIGHT CLEAR CONDITION

- When the OK driving cycle was completed 3 times in a row
- When "Clear Memory" was performed

## Diagnostic Trouble Code (DTC) Detecting Criteria

GENERAL DESCRIPTION

### 8. FAIL SAFE

Make the throttle angle to 3/8, and the line pressure and 2-4B pressure to maximum.

### 9. ECM OPERATION AT DTC SETTING

Memorize the freeze frame data. (For test mode \$02)



# Diagnostic Trouble Code (DTC) Detecting Criteria

## GENERAL DESCRIPTION

### EC:DTC P1711 ENGINE TORQUE CONTROL SIGNAL #1 CIRCUIT MALFUNCTION

#### 1. OUTLINE OF DIAGNOSIS

Judge NG when detecting the difference 250 times in a row by comparing the CPU output with signal line output every 10 milliseconds.

#### 2. ENABLE CONDITION

Secondary Parameters	Enable Conditions
None	

#### 3. GENERAL DRIVING CYCLE

Always perform the diagnosis.

#### 4. DIAGNOSTIC METHOD

##### Judgment Value

Malfunction Criteria	Threshold Value
Collector voltage of transistor (Vc) at "ON" signal from TCM	High level
Collector voltage of transistor (Vc) at "OFF" signal from ECM	Low level

**Time Needed for Diagnosis:** 2.5 seconds

**Malfunction Indicator Light Illumination:** Illuminates when malfunction occurs in 2 continuous driving cycles.

#### 5. DTC CLEAR CONDITION

- When the OK idling cycle was completed 40 times in a row
- When "Clear Memory" was performed

#### 6. MALFUNCTION INDICATOR LIGHT CLEAR CONDITION

- When the OK driving cycle was completed 3 times in a row
- When "Clear Memory" was performed

#### 7. FAIL SAFE

None

#### 8. ECM OPERATION AT DTC SETTING

Memorize the freeze frame data. (For test mode \$02)

# Diagnostic Trouble Code (DTC) Detecting Criteria

GENERAL DESCRIPTION

## ED:DTC P1712 ENGINE TORQUE CONTROL SIGNAL #2 CIRCUIT MALFUNCTION

### 1. OUTLINE OF DIAGNOSIS

Judge NG when detecting the difference 250 times in a row by comparing the CPU output with signal line output every 10 milliseconds.

### 2. ENABLE CONDITION

Secondary Parameters	Enable Conditions
None	

### 3. GENERAL DRIVING CYCLE

Always perform the diagnosis.

### 4. DIAGNOSTIC METHOD

#### Judgment Value

Malfunction Criteria	Threshold Value
Vc at "ON" signal from ECM	High level
Vc at "OFF" signal from ECM	Low level

**Time Needed for Diagnosis:** 2.5 seconds

**Malfunction Indicator Light Illumination:** Illuminates when malfunction occurs in 2 continuous driving cycles.

### 5. DTC CLEAR CONDITION

- When the OK idling cycle was completed 40 times in a row
- When "Clear Memory" was performed

### 6. MALFUNCTION INDICATOR LIGHT CLEAR CONDITION

- When the OK driving cycle was completed 3 times in a row
- When "Clear Memory" was performed

### 7. FAIL SAFE

None

### 8. ECM OPERATION AT DTC SETTING

Memorize the freeze frame data. (For test mode \$02)

# Diagnostic Trouble Code (DTC) Detecting Criteria

## GENERAL DESCRIPTION

### EE:DTC P2096 POST CATALYST FUEL TRIM SYSTEM TOO LEAN BANK 1

#### 1. OUTLINE OF DIAGNOSIS

Detect the malfunction of fuel system from the amount of sub feedback control.

Sub feedback control amount sticks to lean sides during sub feedback control.

Judge NG when the rear oxygen sensor output does not come close to target voltage (slice level).

#### 2. COMPONENT DESCRIPTION

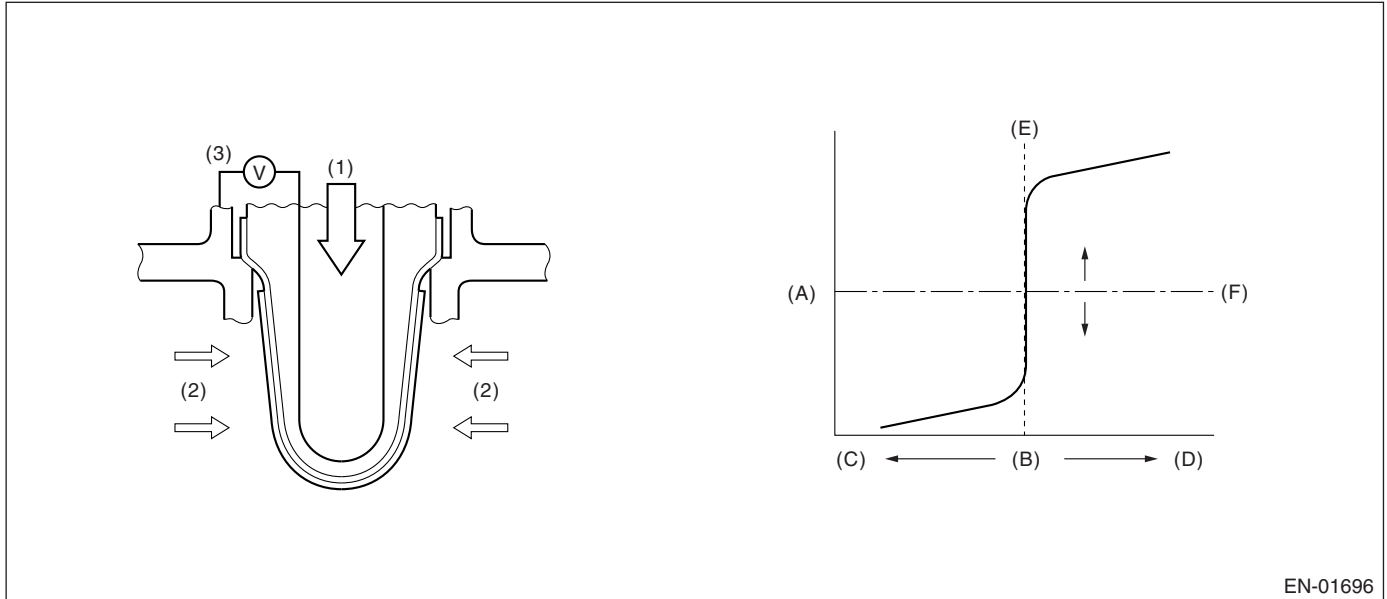

- (1) Atmosphere
- (2) Exhaust gas
- (3) Electromotive force

- (A) Electromotive force
- (B) Air fuel ratio
- (C) Rich
- (D) Lean
- (E) Theoretical air fuel ratio
- (F) Comparative voltage

#### 3. ENABLE CONDITION

Secondary Parameters	Enable Conditions
Main feedback	In operation
Sub feedback	In operation
Amount of intake air	≥ 9 g/sec
Sub feedback	Sticks to the limit value (lean side)

#### 4. GENERAL DRIVING CYCLE

Perform the diagnosis continuously at a constant 80 km/h (50 MPH).

# Diagnostic Trouble Code (DTC) Detecting Criteria

GENERAL DESCRIPTION

## 5. DIAGNOSTIC METHOD

### • Abnormality Judgment

Calculate the continuous time from the sticking of sub feedback control amount to lean side and cumulative deviation (sumdelo2) of rear oxygen sensor voltage and target voltage.

Judge NG when the malfunction criteria below are completed after 300 seconds have passed continuously.

### Judgment Value

Malfunction Criteria	Threshold Value
$\text{sumdelo2} = \text{sumdelo2} + (\text{rvo2} - \text{rsl})$ where: rvo2 = sensing voltage of O <sub>2</sub> sensor rsl = target voltage of O <sub>2</sub> sensor	> -2,750 V

**Time Needed for Diagnosis:** 300 seconds

**Malfunction Indicator Light Illumination:** Illuminates when malfunction occurs in 2 continuous driving cycles.

### • Normality Judgment

Judge OK and clear the NG when the rear oxygen output is reversed, and during 4 seconds after that, the sub feedback control amount does not stick to rich or lean sides.

## 6. DTC CLEAR CONDITION

- When the OK idling cycle was completed 40 times in a row
- When "Clear Memory" was performed

## 7. MALFUNCTION INDICATOR LIGHT CLEAR CONDITION

- When OK with similar drive in 3 drive cycles.
- When "Clear Memory" was performed

## 8. FAIL SAFE

None

## 9. ECM OPERATION AT DTC SETTING

Memorize the freeze frame data. (For test mode \$02)

# Diagnostic Trouble Code (DTC) Detecting Criteria

## GENERAL DESCRIPTION

### EF:DTC P2097 POST CATALYST FUEL TRIM SYSTEM TOO RICH BANK 1

#### 1. OUTLINE OF DIAGNOSIS

Detect the malfunction of fuel system from the amount of sub feedback control.

Sub feedback control amount sticks to rich sides during sub feedback control.

Judge NG when the rear oxygen sensor output does not come close to target voltage (slice level).

#### 2. COMPONENT DESCRIPTION

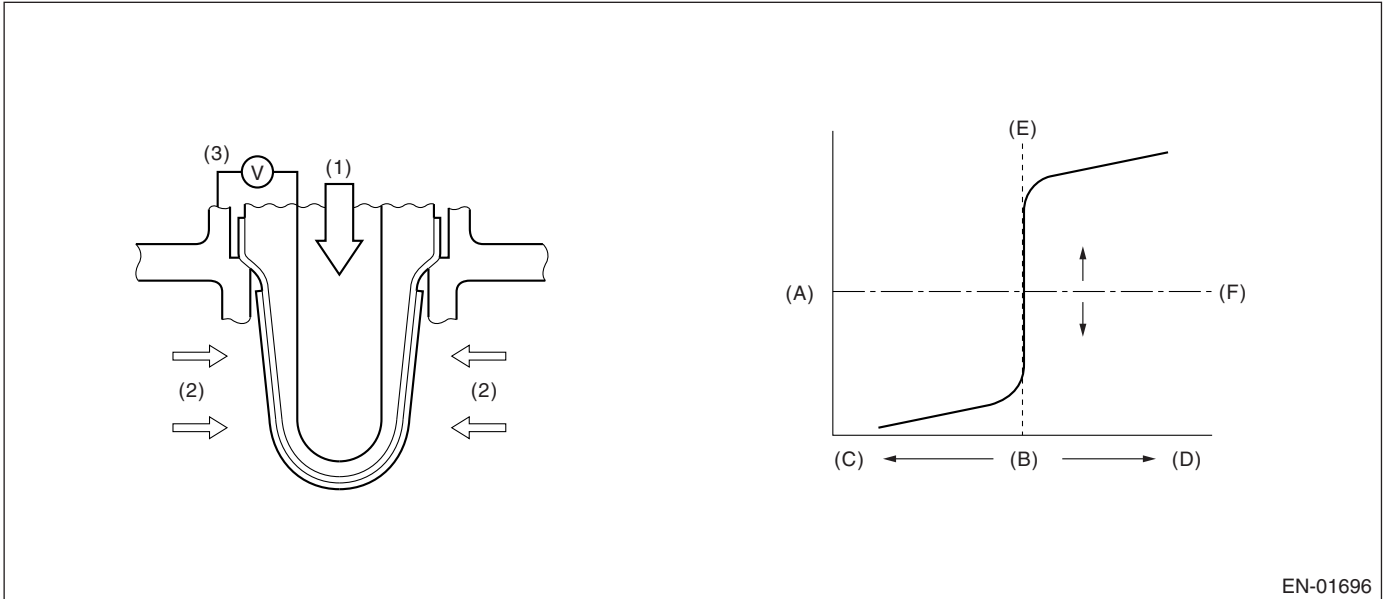

- (1) Atmosphere
- (2) Exhaust gas
- (3) Electromotive force

- (A) Electromotive force
- (B) Air fuel ratio
- (C) Rich
- (D) Lean
- (E) Theoretical air fuel ratio
- (F) Comparative voltage

#### 3. ENABLE CONDITION

Secondary Parameters	Enable Conditions
Main feedback	In operation
Sub feedback	In operation
Amount of intake air	$\geq 9$ g/sec
Sub feedback	Sticks to the limit value (rich side)

#### 4. GENERAL DRIVING CYCLE

Perform the diagnosis continuously at a constant 80 km/h (50 MPH).

# Diagnostic Trouble Code (DTC) Detecting Criteria

GENERAL DESCRIPTION

## 5. DIAGNOSTIC METHOD

### • Abnormality Judgment

Calculate the continuous time from the sticking of sub feedback control amount to rich side and cumulative deviation (sumdelo2) of rear oxygen sensor voltage and target voltage.

Judge NG when the malfunction criteria below are completed after 300 seconds have passed continuously.

### Judgment Value

Malfunction Criteria	Threshold Value
$\text{sumdelo2} = \text{sumdelo2} + (\text{rvo2} - \text{rsl})$ where: rvo2 = sensing voltage of O <sub>2</sub> sensor rsl = target voltage of O <sub>2</sub> sensor	> 850 V

**Time Needed for Diagnosis:** 300 seconds

**Malfunction Indicator Light Illumination:** Illuminates when malfunction occurs in 2 continuous drive cycles.

### • Normality Judgment

Judge OK and clear the NG when the rear oxygen output is reversed, and during 4 seconds after that, the sub feedback control amount does not stick to rich or lean sides.

## 6. DTC CLEAR CONDITION

- When the OK idling cycle was completed 40 times in a row
- When "Clear Memory" was performed

## 7. MALFUNCTION INDICATOR LIGHT CLEAR CONDITION

- When OK with similar drive in 3 drive cycles.
- When "Clear Memory" was performed

## 8. FAIL SAFE

None

## 9. ECM OPERATION AT DTC SETTING

Memorize the freeze frame data. (For test mode \$02)

# Diagnostic Trouble Code (DTC) Detecting Criteria

GENERAL DESCRIPTION

---

Brought to you by Eris Studios  
NOT FOR RESALE