

Brought to you by Eris Studios
NOT FOR RESALE

ENGINE (DIAGNOSTICS)

Basic Diagnostic Procedure

ENGINE (DIAGNOSTICS)

1. Basic Diagnostic Procedure

A: PROCEDURE

1. ENGINE

Step	Check	Yes	No
1 CHECK ENGINE START FAILURE. 1) Ask the customer when and how the trouble occurred using the check list for interview. <Ref. to EN(H4SO)(diag)-4, CHECK, Check List for Interview.> 2) Start the engine.	Does the engine start?	Go to step 2.	Inspection using "Diagnostics for Engine Start Failure". <Ref. to EN(H4SO)(diag)-56, Diagnostics for Engine Starting Failure.>
2 CHECK ILLUMINATION OF MALFUNCTION INDICATOR LIGHT.	Does malfunction indicator light illuminate?	Go to step 3.	Inspection using "General Diagnostics Table". <Ref. to EN(H4SO)(diag)-304, INSPECTION, General Diagnostic Table.>
3 CHECK INDICATION OF DTC ON DISPLAY. 1) Turn the ignition switch to OFF. 2) Connect the Subaru Select Monitor or the OBD-II general scan tool to data link connector. 3) Turn the ignition switch to ON and the Subaru Select Monitor or OBD-II general scan tool switch to ON. 4) Read the DTC on the Subaru Select Monitor or OBD-II general scan tool.	Does the Subaru Select Monitor or OBD-II general scan tool indicate DTC?	Record the DTC. Repair the trouble cause. <Ref. to EN(H4SO)(diag)-71, List of Diagnostic Trouble Code (DTC).> Go to step 4.	Repair the related parts. NOTE: If DTC is not shown on display although the malfunction indicator light illuminates, perform diagnostics of malfunction indicator light circuit or combination meter. <Ref. to EN(H4SO)(diag)-47, Malfunction Indicator Light.>
4 PERFORM THE DIAGNOSIS. 1) Perform the clear memory mode. <Ref. to EN(H4SO)(diag)-44, Clear Memory Mode.> 2) Perform the inspection mode. <Ref. to EN(H4SO)(diag)-37, Inspection Mode.>	Does the Subaru Select Monitor or OBD-II general scan tool indicate DTC?	Inspect using "Diagnostics Procedure with Diagnostic Trouble Code (DTC)". <Ref. to EN(H4SO)(diag)-78, Diagnostic Procedure with Diagnostic Trouble Code (DTC).>	Complete the diagnosis.

2. AUTOMATIC TRANSMISSION

When the DTC about automatic transmission is shown on display, carry out the following basic check. After that, carry out the replacement or repair work.

- 1) ATF level check <Ref. to 4AT-30, Automatic Transmission Fluid.>
- 2) Differential gear oil level check <Ref. to 4AT-31, Differential Gear Oil.>
- 3) ATF leak check <Ref. to 4AT-30, Automatic Transmission Fluid.>
- 4) Differential gear oil leak check <Ref. to 4AT-31, Differential Gear Oil.>
- 5) Stall test <Ref. to 4AT-33, Stall Test.>
- 6) Line pressure test <Ref. to 4AT-35, Line Pressure Test.>
- 7) Transfer clutch pressure test <Ref. to 4AT-36, Transfer Clutch Pressure Test.>
- 8) Time lag test <Ref. to 4AT-34, Time Lag Test.>
- 9) Road test <Ref. to 4AT-32, Road Test.>
- 10) Shift characteristics <Ref. to 4AT-36, Transfer Clutch Pressure Test.>

Check List for Interview

ENGINE (DIAGNOSTICS)

Brought to you by Eris Studios
NOT FOR RESALE

2. Check List for Interview

A: CHECK

1. CHECK LIST No. 1

Check the following items when problem has occurred.

NOTE:

Use copies of this page for interviewing customers.

Customer's name		Engine No.	
Date of sale		Fuel brand	
Date of repair		Odometer reading	km
VIN No.			miles
Weather	<input type="checkbox"/> Fine <input type="checkbox"/> Cloudy <input type="checkbox"/> Rainy <input type="checkbox"/> Snowy <input type="checkbox"/> Various/Others:		
Outdoor temperature	°C (°F)		
	<input type="checkbox"/> Hot <input type="checkbox"/> Warm <input type="checkbox"/> Cool <input type="checkbox"/> Cold		
Place	<input type="checkbox"/> Highway <input type="checkbox"/> Suburbs <input type="checkbox"/> Inner city <input type="checkbox"/> Uphill <input type="checkbox"/> Downhill <input type="checkbox"/> Rough road <input type="checkbox"/> Others:		
Engine temperature	<input type="checkbox"/> Cold <input type="checkbox"/> Warming-up <input type="checkbox"/> After warming-up <input type="checkbox"/> Any temperature <input type="checkbox"/> Others:		
Engine speed	rpm		
Vehicle speed	MPH		
Driving conditions	<input type="checkbox"/> Not affected <input type="checkbox"/> At starting <input type="checkbox"/> While idling <input type="checkbox"/> At racing <input type="checkbox"/> While accelerating <input type="checkbox"/> While cruising <input type="checkbox"/> While decelerating <input type="checkbox"/> While turning (RH/LH)		
Headlight	<input type="checkbox"/> ON / <input type="checkbox"/> OFF	Rear defogger	<input type="checkbox"/> ON / <input type="checkbox"/> OFF
Blower	<input type="checkbox"/> ON / <input type="checkbox"/> OFF	Radio	<input type="checkbox"/> ON / <input type="checkbox"/> OFF
A/C compressor	<input type="checkbox"/> ON / <input type="checkbox"/> OFF	CD/Cassette	<input type="checkbox"/> ON / <input type="checkbox"/> OFF
Radiator fan	<input type="checkbox"/> ON / <input type="checkbox"/> OFF	Car phone	<input type="checkbox"/> ON / <input type="checkbox"/> OFF
Front wiper	<input type="checkbox"/> ON / <input type="checkbox"/> OFF	CB	<input type="checkbox"/> ON / <input type="checkbox"/> OFF
Rear wiper	<input type="checkbox"/> ON / <input type="checkbox"/> OFF		

Check List for Interview

ENGINE (DIAGNOSTICS)

2. CHECK LIST No. 2

Check the following items about the vehicle's state when malfunction indicator light turns on.

NOTE:

Use copies of this page for interviewing customers.

a) Other warning lights or indicators turn on. <input type="checkbox"/> Yes / <input type="checkbox"/> No
<input type="checkbox"/> Low fuel warning light <input type="checkbox"/> Charge indicator light <input type="checkbox"/> AT diagnostics indicator light <input type="checkbox"/> ABS warning light <input type="checkbox"/> Engine oil pressure warning light
b) Fuel level
<ul style="list-style-type: none">• Lack of gasoline: <input type="checkbox"/> Yes / <input type="checkbox"/> No• Indicator position of fuel gauge:
c) Intentional connecting or disconnecting of harness connectors or spark plug cords: <input type="checkbox"/> Yes / <input type="checkbox"/> No
<ul style="list-style-type: none">• What:
d) Intentional connecting or disconnecting of hoses: <input type="checkbox"/> Yes / <input type="checkbox"/> No
<ul style="list-style-type: none">• What:
e) Installing of parts other than genuine parts: <input type="checkbox"/> Yes / <input type="checkbox"/> No
<ul style="list-style-type: none">• What:• Where:
f) Occurrence of noise: <input type="checkbox"/> Yes / <input type="checkbox"/> No
<ul style="list-style-type: none">• From where:• What kind:
g) Occurrence of smell: <input type="checkbox"/> Yes / <input type="checkbox"/> No
<ul style="list-style-type: none">• From where:• What kind:
h) Intrusion of water into engine compartment or passenger compartment: <input type="checkbox"/> Yes / <input type="checkbox"/> No
i) Troubles occurred
<input type="checkbox"/> Engine does not start. <input type="checkbox"/> Engine stalls during idling. <input type="checkbox"/> Engine stalls while driving. <input type="checkbox"/> Engine speed decreases. <input type="checkbox"/> Engine speed does not decrease. <input type="checkbox"/> Rough idling <input type="checkbox"/> Poor acceleration <input type="checkbox"/> Back fire <input type="checkbox"/> After fire <input type="checkbox"/> No shift <input type="checkbox"/> Excessive shift shock

3. General Description

A: CAUTION

1) Airbag system wiring harness is routed near the ECM, main relay and fuel pump relay.

CAUTION:

- All airbag system wiring harness and connectors are colored yellow. Do not use electrical test equipment on these circuit.
- Be careful not to damage the airbag system wiring harness when servicing the ECM, TCM, main relay and fuel pump relay.

2) Never connect the battery in reverse polarity.

- The ECM will be destroyed instantly.
- The fuel injector and other part will be damaged in just a few minutes more.

3) Do not disconnect the battery terminals while the engine is running.

A large counter electromotive force will be generated in the generator, and this voltage may damage electronic parts such as ECM, etc.

4) Before disconnecting the connectors of each sensor and the ECM, be sure to turn OFF the ignition switch.

5) Poor contact has been identified as a primary cause of this problem. To measure the voltage and/or resistance of individual sensors or all electrical control modules at the harness side connector, use a tapered pin with a diameter of less than 0.64 mm (0.025 in). Do not insert the pin more than 5 mm (0.20 in) into the part.

6) Before removing the ECM from the located position, disconnect two cables on battery. Otherwise, the ECM may be damaged.

CAUTION:

When replacing the ECM, be careful not to use the wrong spec. ECM to avoid any damage on fuel injection system.

7) The connectors to each sensor in the engine compartment and the harness connectors on the engine side and body side are all designed to be waterproof. However, it is still necessary to take care not to allow water to get into the connectors when washing the vehicle, or when servicing the vehicle on a rainy day.

8) Use ECM mounting stud bolts at the body side grounding point when measuring voltage and resistance inside the passenger compartment.

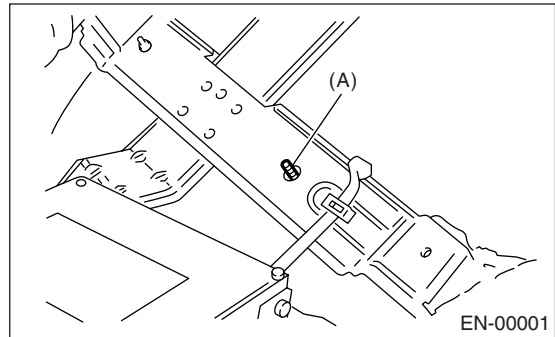

(A) Stud bolt

9) Use engine grounding terminal or engine proper as the grounding point to the body when measuring voltage and resistance in the engine compartment.

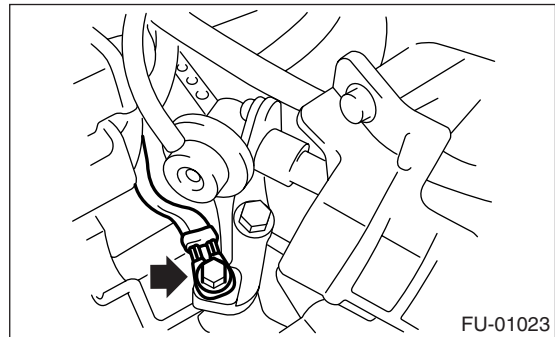

10) Use TCM mounting stud bolts at the body side grounding point when measuring voltage and resistance inside the passenger compartment.

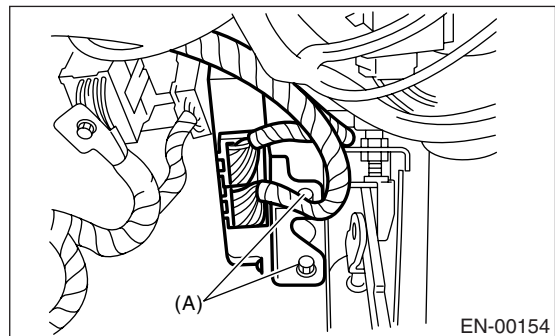

(A) Stud bolt

11) Every MFI-related part is a precision part. Do not drop them.

12) Observe the following cautions when installing a radio in MFI equipped models.

CAUTION:

- The antenna must be kept as far apart as possible from the control unit. (The ECM is located under the steering column, inside of the instrument panel lower trim panel.)
- The antenna feeder must be placed as far apart as possible from the ECM and MFI harness.
- Carefully adjust the antenna for correct matching.
- When mounting a large power type radio, pay special attention to the three items above mentioned.
- Incorrect installation of the radio may affect the operation of the ECM.

13) Before disconnecting the fuel hose, disconnect the fuel pump connector and crank the engine for more than five seconds to release pressure in the fuel system. If engine starts during this operation, run it until it stops.

14) Problems in the electronic-controlled automatic transmission may be caused by failure of the engine, the electronic control system, the transmission proper, or by a combination of these. These three causes must be distinguished clearly when performing diagnostics.

15) Diagnostics should be conducted by rotating with simple, easy operations and proceeding to complicated, difficult operations. The most important thing in diagnostics is to understand the customer's complaint, and distinguish between the three causes.

16) In AT models, do not continue the stall for more than five seconds at a time (from closed throttle, fully open throttle to stall engine speed).

17) On models with ABS, when performing driving test in jacked-up or lifted-up position, sometimes the warning light may be lit, but this is not a malfunction of the system. The reason for this is the speed difference between the front and rear wheels. After diagnosis of engine control system, perform the ABS memory clearance procedure of self-diagnosis system.

B: INSPECTION

Before performing diagnostics, check the following items which might affect engine problems:

1. BATTERY

1) Measure battery voltage and specific gravity of electrolyte.

Standard voltage: 12 V

Specific gravity: Above 1.260

2) Check the condition of the main and other fuses, and harnesses and connectors. Also check for proper grounding.

2. ENGINE GROUNDING

Make sure the engine grounding terminal is properly connected to the engine.

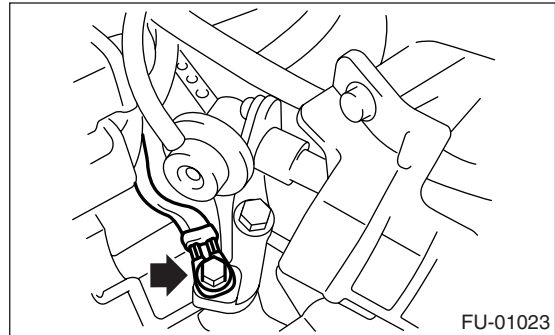

C: NOTE

1. DESCRIPTION

- The on-board diagnostics (OBD) system detects and indicates a fault in various inputs and outputs of the complex electronic control. Malfunction indicator light in the combination meter indicates occurrence of a fault or trouble.
- Further, against such a failure or sensors as may disable the drive, the fail-safe function is provided to ensure the minimal driveability.
- The OBD system incorporated with the vehicles within this engine family complies with Section 1968.1, California Code of Regulations (OBD-II regulation). The OBD system monitors the components and the system malfunction listed in Engine Section which affects on emissions.
- When the system decides that a malfunction occurs, malfunction indicator light illuminates. At the same time of the malfunction indicator light illumination or blinking, a DTC and a freeze frame engine conditions are stored into on-board computer.
- The OBD system stores freeze frame engine condition data (engine load, engine coolant temperature, fuel trim, engine speed and vehicle speed, etc.) into on-board computer when it detects a malfunction first.
- If the OBD system detects the various malfunctions including the fault of fuel trim or misfire, the OBD system first stores freeze frame engine conditions about the fuel trim or misfire.
- When the malfunction does not occur again for three consecutive driving cycles, malfunction indicator light is turned off, but DTC remains at on-board computer.
- The OBD-II system is capable of communication with a general scan tool (OBD-II general scan tool) formed by ISO 9141 CARB.

General Description

ENGINE (DIAGNOSTICS)

- The OBD-II diagnostics procedure is different from the usual diagnostics procedure. When troubleshooting the models with OBD-II, connect Subaru Select Monitor or the OBD-II general scan tool to the vehicle.

2. ENGINE AND EMISSION CONTROL SYSTEM

- The Multipoint Fuel Injection (MFI) system is a system that supplies the optimum air-fuel mixture to the engine for all the various operating conditions through the use of the latest electronic technology.

With this system fuel, which is pressurized at a constant pressure, is injected into the intake air passage of the cylinder head. The injection quantity of fuel is controlled by an intermittent injection system where the electro-magnetic injection valve (fuel injector) opens only for a short period of time, depending on the quantity of air required for one cycle of operation. In actual operation, the injection quantity is determined by the duration of an electric pulse applied to the fuel injector and this permits simple, yet highly precise metering of the fuel.

- Further, all the operating conditions of the engine are converted into electric signals, and this results in additional features of the system, such as large improved adaptability, easier addition of compensating element, etc.



The MFI system also has the following features:

- Reduced emission of harmful exhaust gases.
- Reduction in fuel consumption.
- Increased engine output.
- Superior acceleration and deceleration.
- Superior startability and warm-up performance in cold weather since compensation is made for coolant and intake air temperature.

3. AUTOMATIC TRANSMISSION AND ELECTRONIC-HYDRAULIC CONTROL SYSTEM

The electronic-hydraulic control system consists of various sensors and switches, the TCM and the hydraulic controller including solenoid valves. The system controls the transmission proper including shift control, lock-up control, overrunning clutch control, line pressure control and shift timing control. It also controls the AWD transfer clutch. In other words, the system detects various operating conditions from various input signals and sends output signals to shift solenoids 1, 2 and low clutch timing solenoid and 2-4 brake timing solenoid, line pressure duty solenoid, lock-up duty solenoid, transfer duty solenoid and 2-4 brake duty solenoid (a total of eight solenoids).

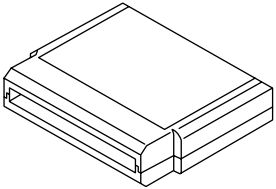
D: PREPARATION TOOL

ILLUSTRATION	TOOL NUMBER	DESCRIPTION	REMARKS
 <p style="text-align: center;">ST24082AA230</p>	24082AA230	CARTRIDGE	Troubleshooting for electrical systems.
 <p style="text-align: center;">ST22771AA030</p>	22771AA030	SUBARU SELECT MONITOR KIT	Troubleshooting for electrical systems.

4. Electrical Components Location

A: LOCATION

1. ENGINE

• MODULE

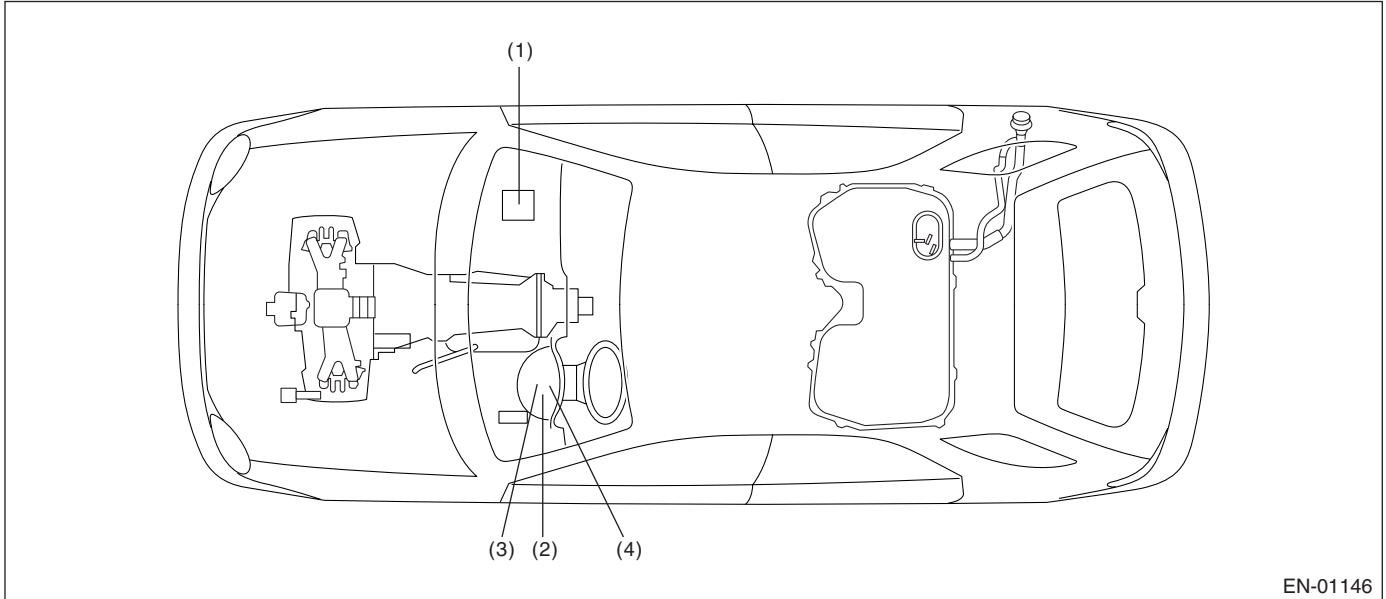

- (1) Engine control module (ECM)
- (2) Malfunction indicator light
- (3) Test mode connector
- (4) Data link connector

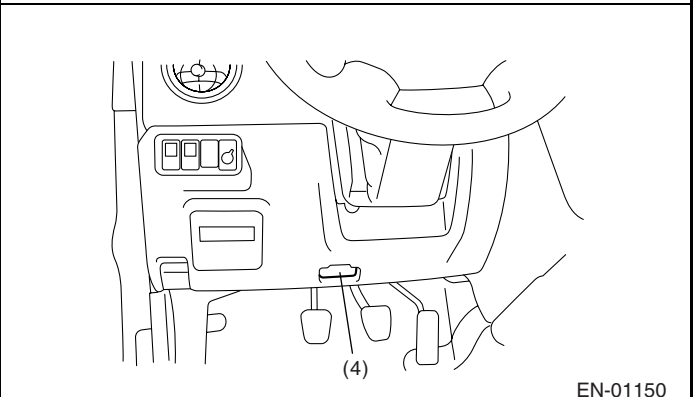
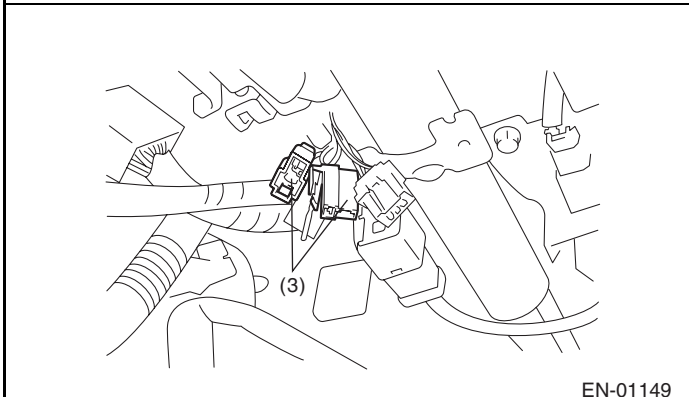
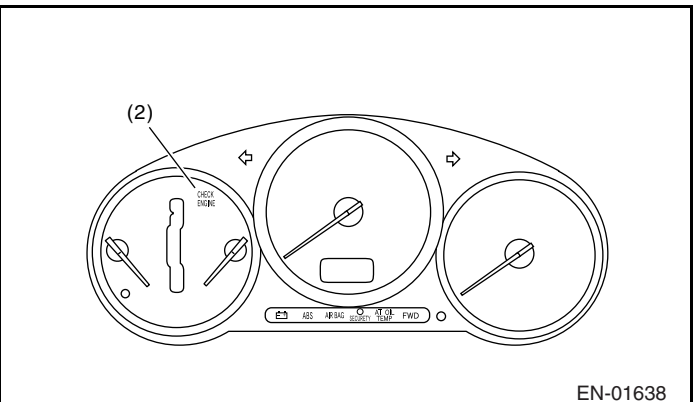
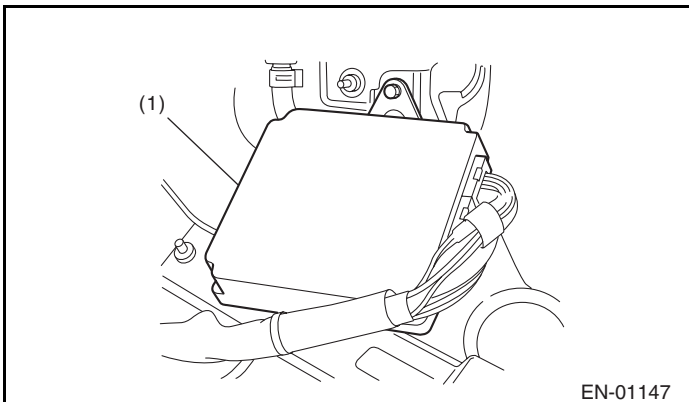

Electrical Components Location

ENGINE (DIAGNOSTICS)

• SENSOR

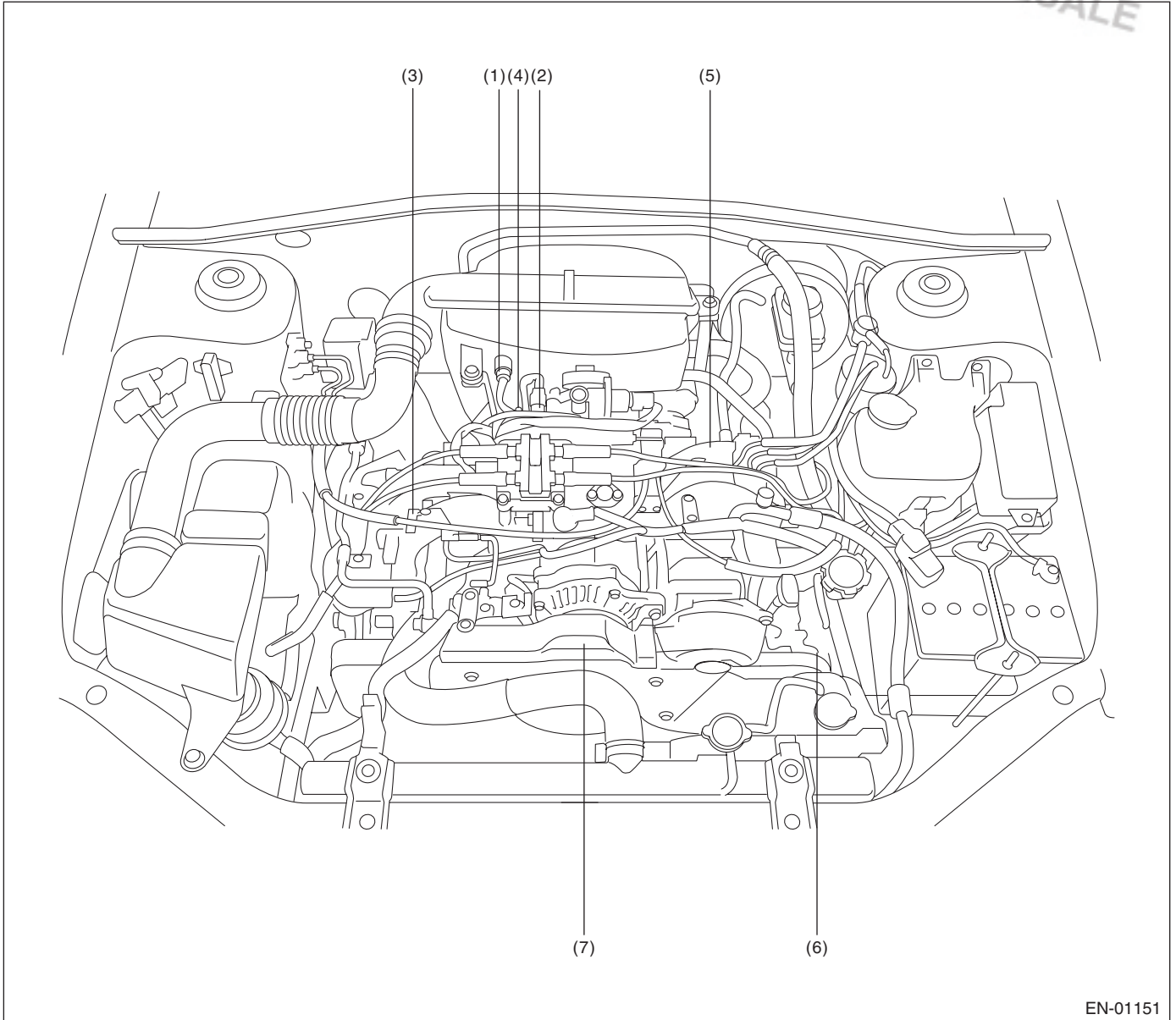

EN-01151

- | | | |
|---------------------------------------|------------------------------|--------------------------------|
| (1) Intake air temperature sensor | (4) Throttle position sensor | (6) Camshaft position sensor |
| (2) Manifold absolute pressure sensor | (5) Knock sensor | (7) Crankshaft position sensor |
| (3) Engine coolant temperature sensor | | |

Electrical Components Location

ENGINE (DIAGNOSTICS)



EN-00006

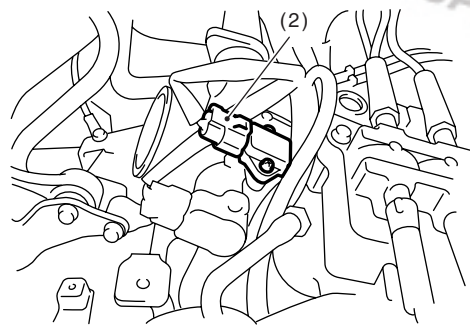

EN-00160

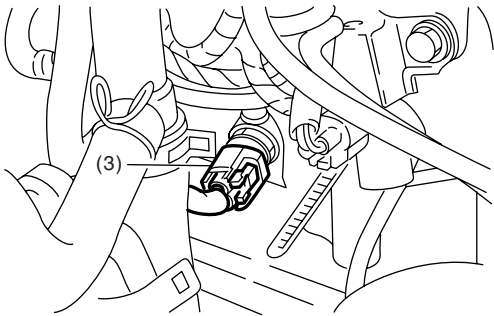

EN-00008

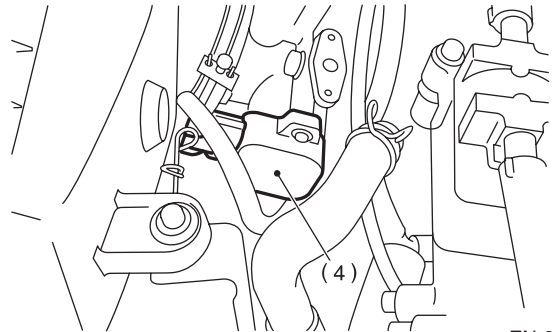

EN-00161

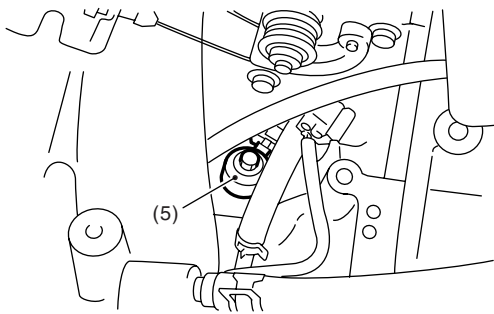

EN-00010

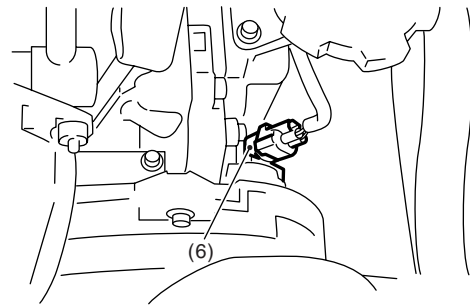

EN-00011

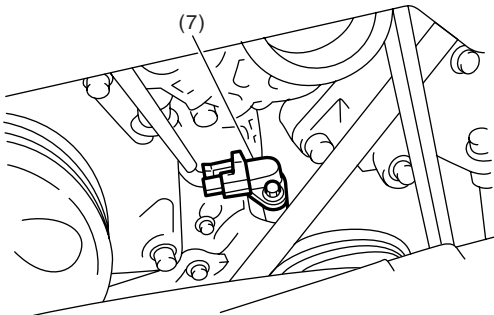

EN-00012

SUBARU.

Electrical Components Location

ENGINE (DIAGNOSTICS)

Brought to you by Eris Studios
NOT FOR RESALE

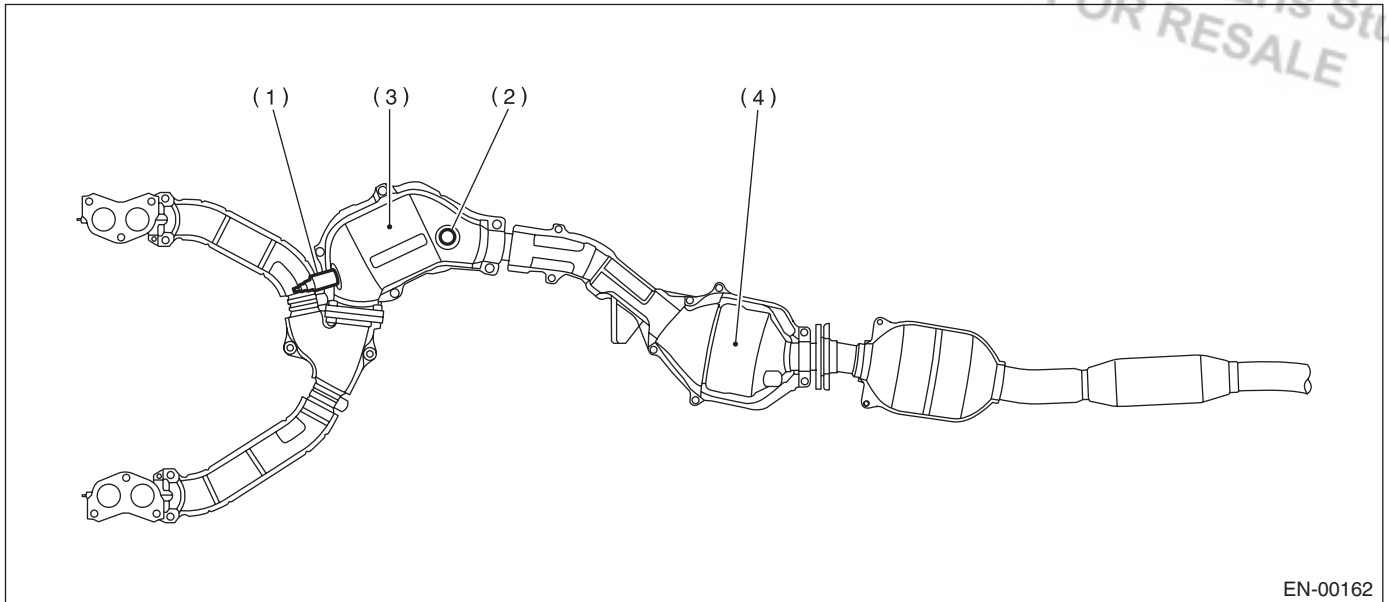

EN-00162

- (1) Front oxygen (A/F) sensor
- (2) Rear oxygen sensor
- (3) Front catalytic converter
- (4) Rear catalytic converter

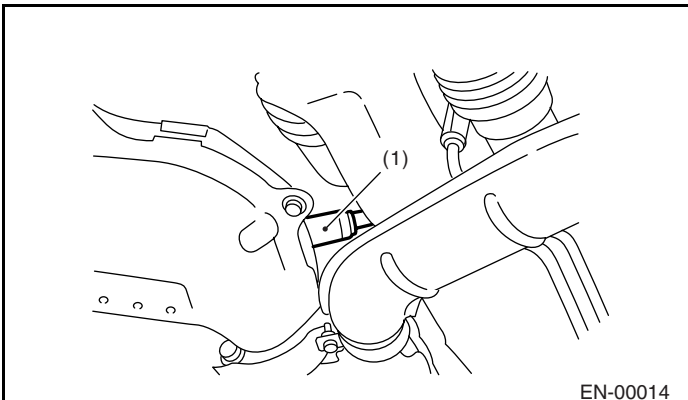

EN-00014

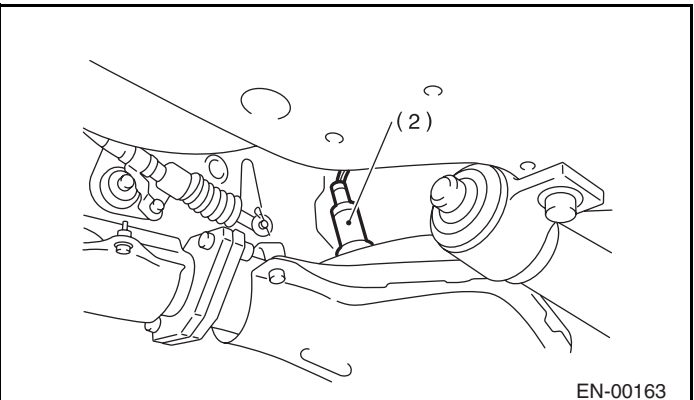

EN-00163

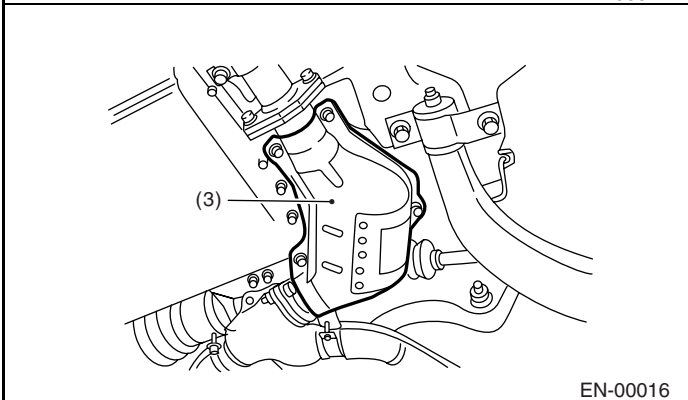

EN-00016

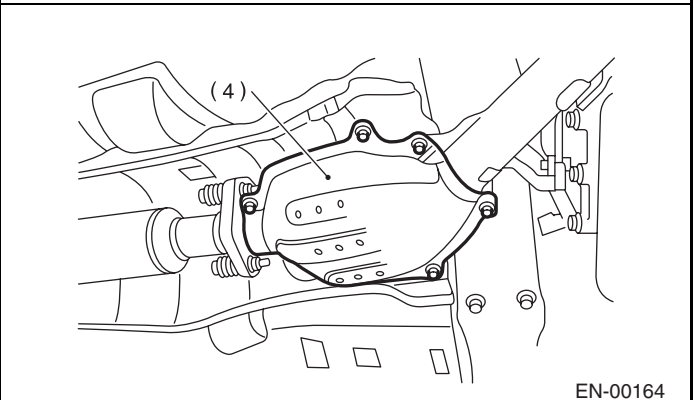

EN-00164

Electrical Components Location

ENGINE (DIAGNOSTICS)

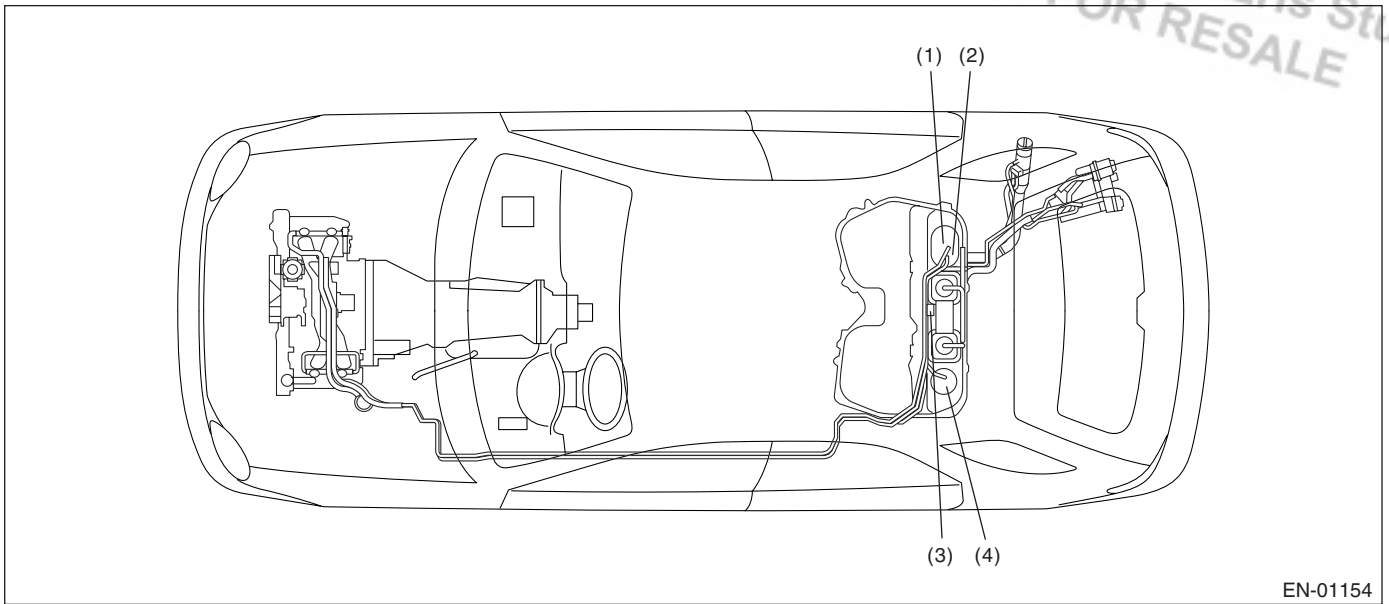

- (1) Fuel level sensor
- (2) Fuel temperature sensor

- (3) Fuel tank pressure sensor

- (4) Fuel sub level sensor

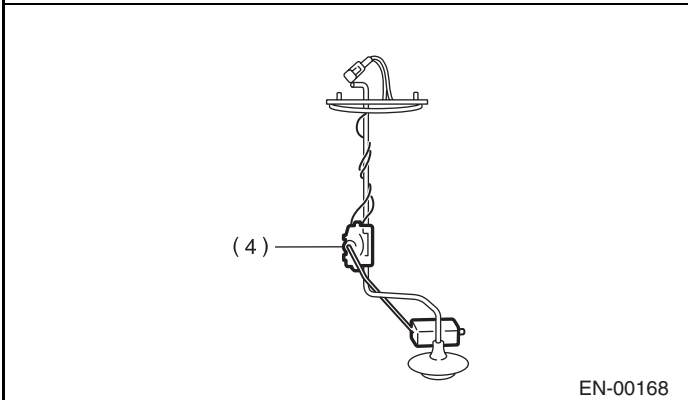
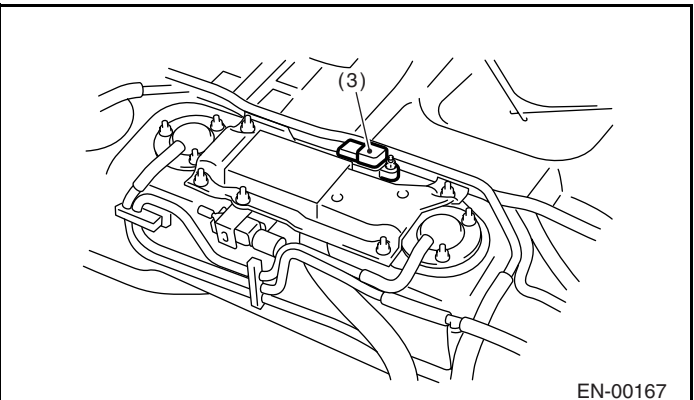
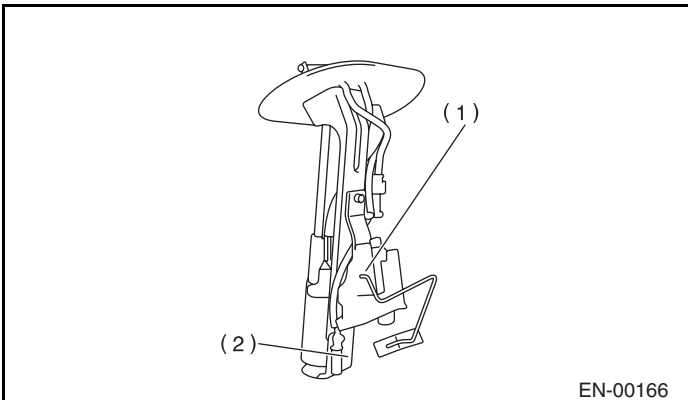

SUBARU.

Electrical Components Location

ENGINE (DIAGNOSTICS)

• SOLENOID VALVE, EMISSION CONTROL SYSTEM PARTS AND IGNITION SYSTEM PARTS

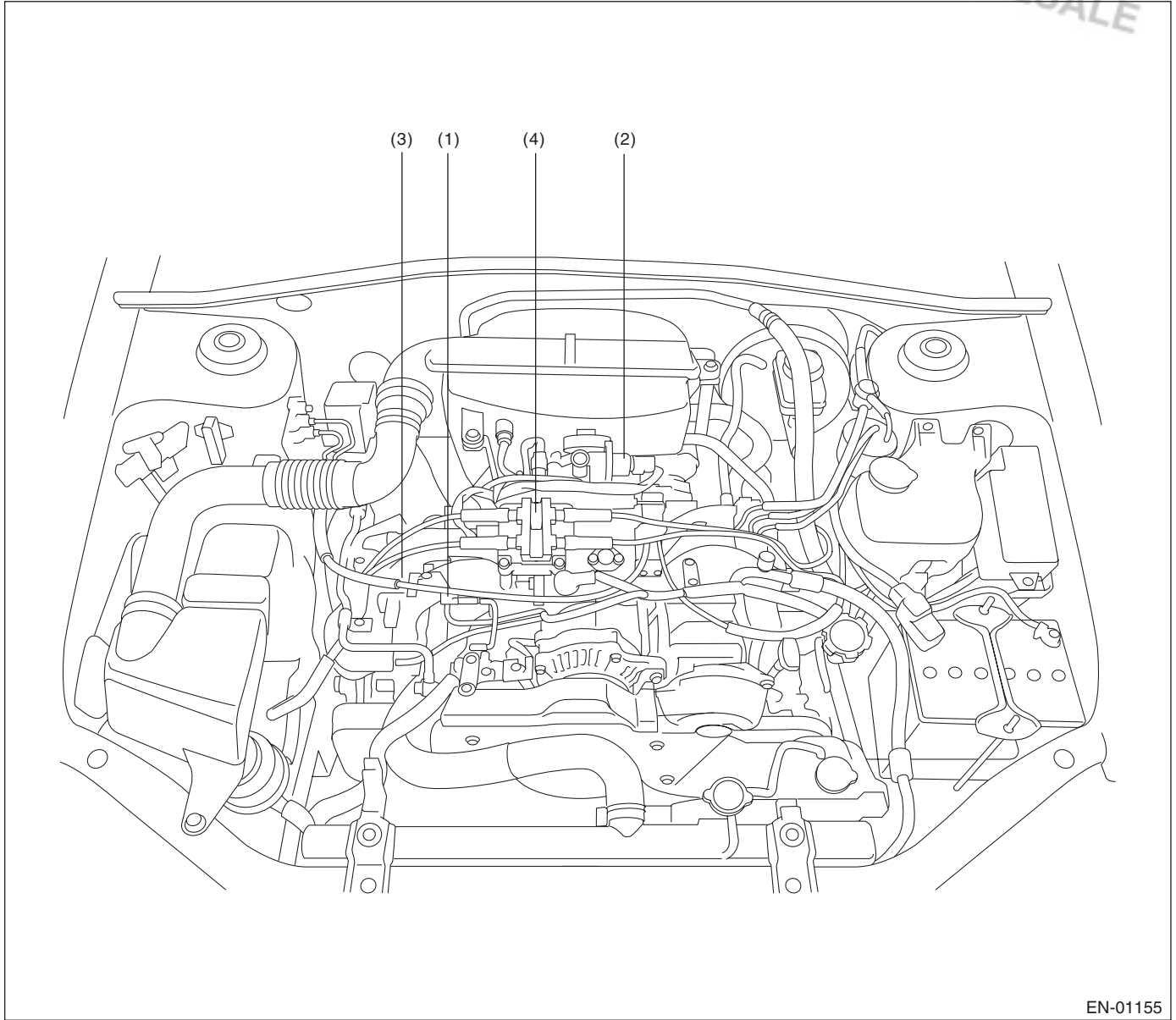

EN-01155

- (1) Air assisted injector solenoid valve
- (2) Idle air control solenoid valve
- (3) Purge control solenoid valve
- (4) Ignition coil & ignitor ASSY

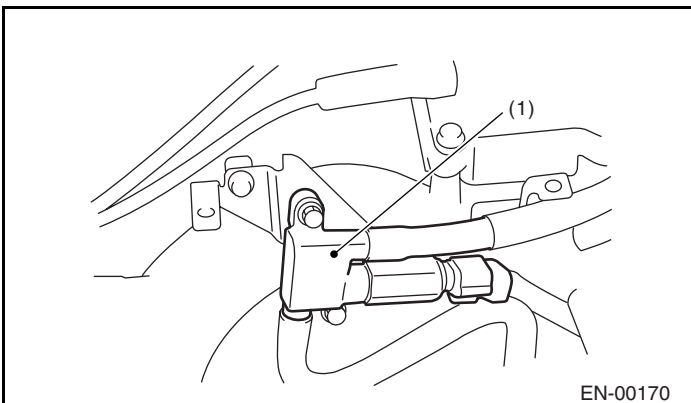

EN-00170

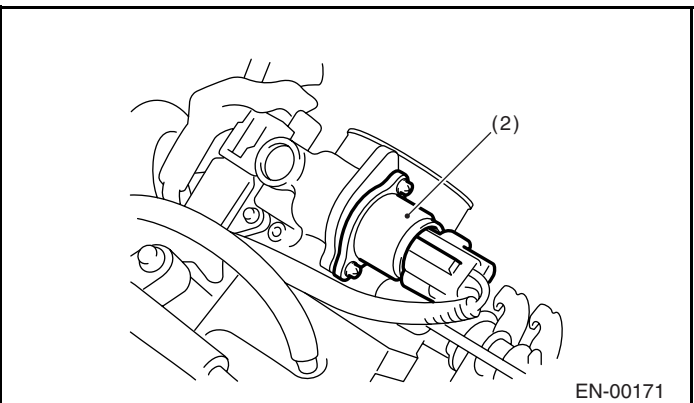

EN-00171

Electrical Components Location

ENGINE (DIAGNOSTICS)

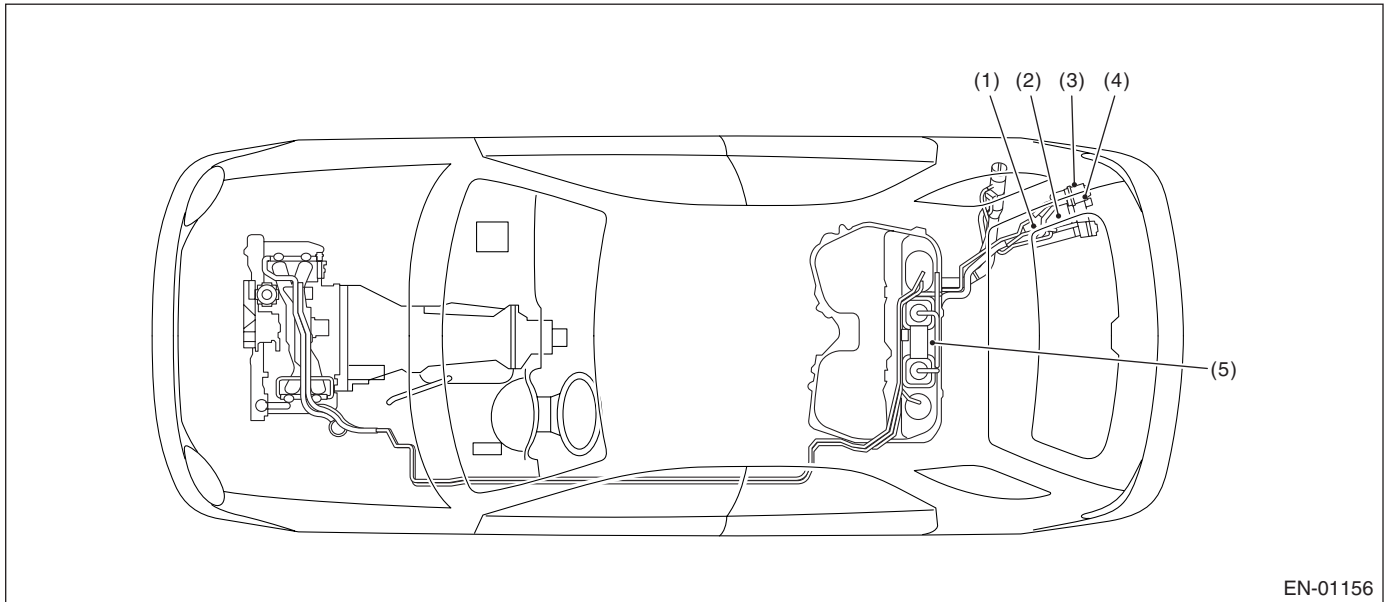
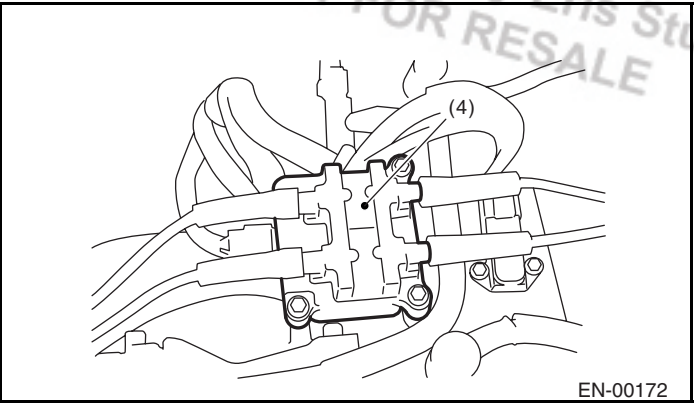
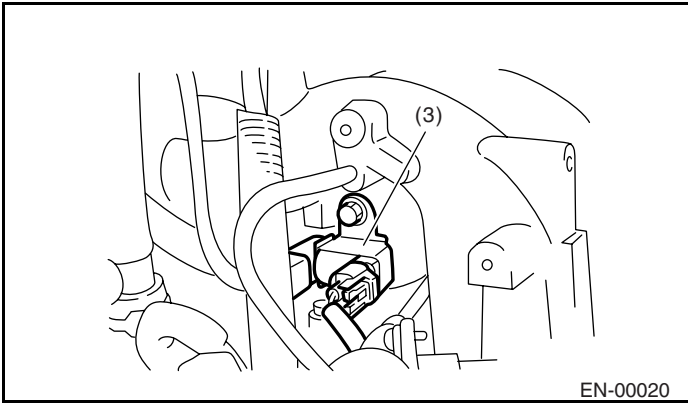

- (1) Pressure control solenoid valve
- (2) Canister
- (3) Drain valve
- (4) Drain filter
- (5) Fuel tank sensor control valve

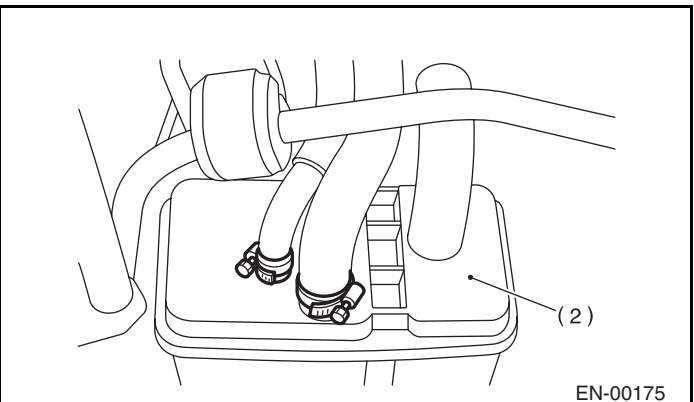
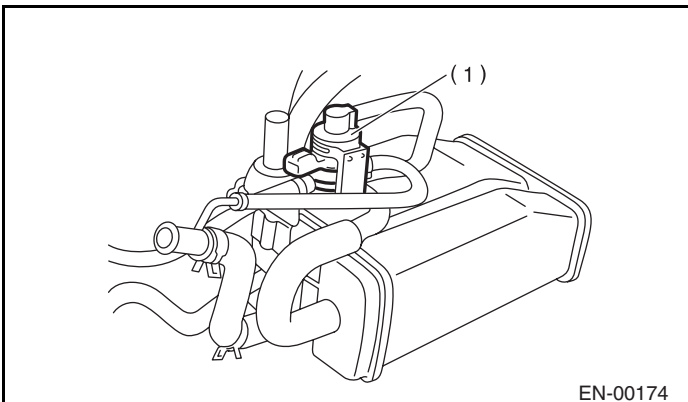

Electrical Components Location

ENGINE (DIAGNOSTICS)

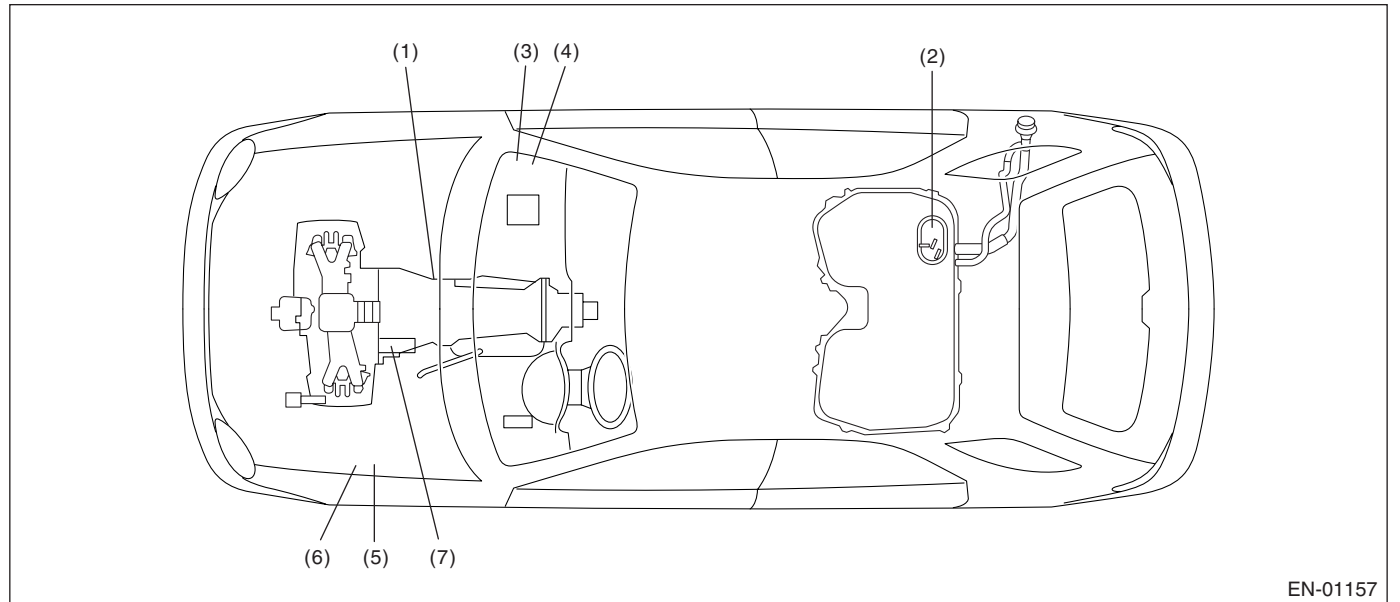
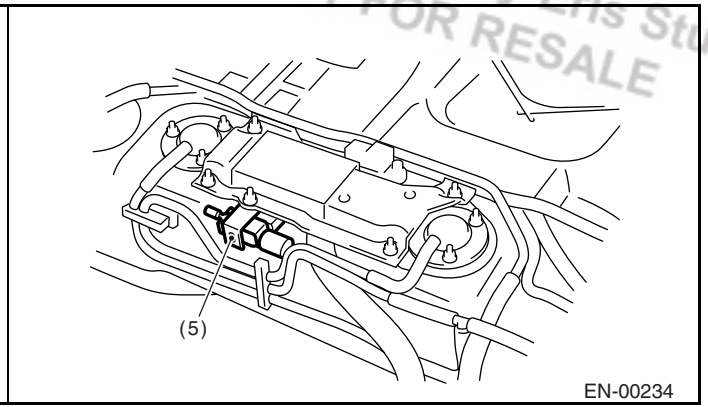
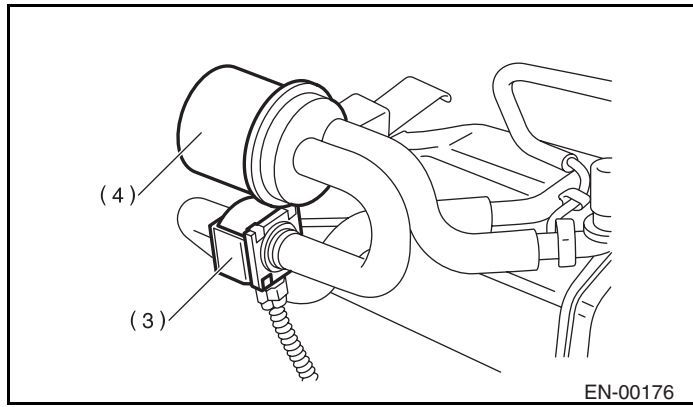

- | | | |
|----------------------|-----------------------------|-------------|
| (1) Inhibitor switch | (4) Fuel pump relay | (7) Starter |
| (2) Fuel pump | (5) Radiator main fan relay | |
| (3) Main relay | (6) Radiator sub fan relay | |

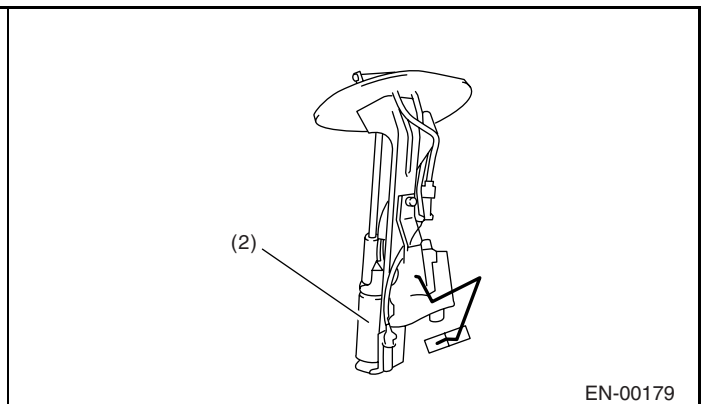
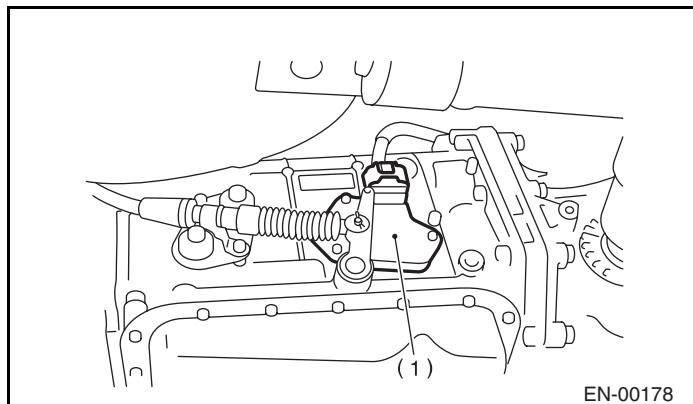

Electrical Components Location

ENGINE (DIAGNOSTICS)

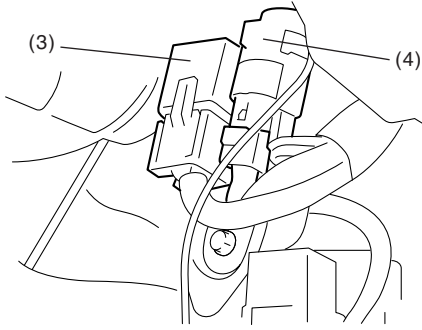

EN-01158

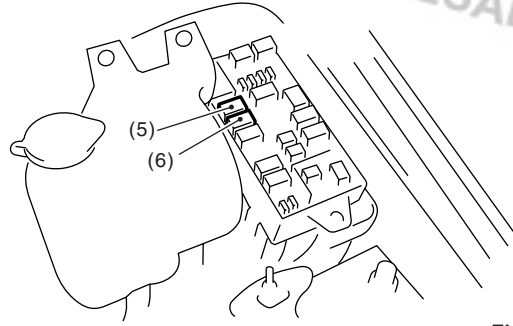

EN-01639

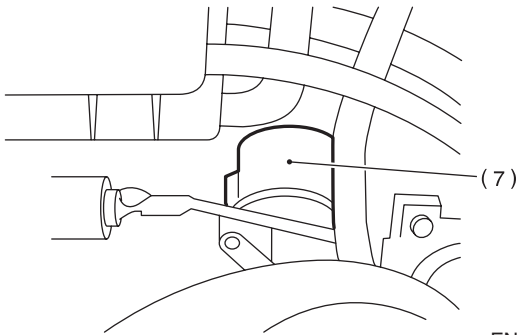

EN-00181

SUBARU.

Electrical Components Location

ENGINE (DIAGNOSTICS)

2. TRANSMISSION

• MODULE

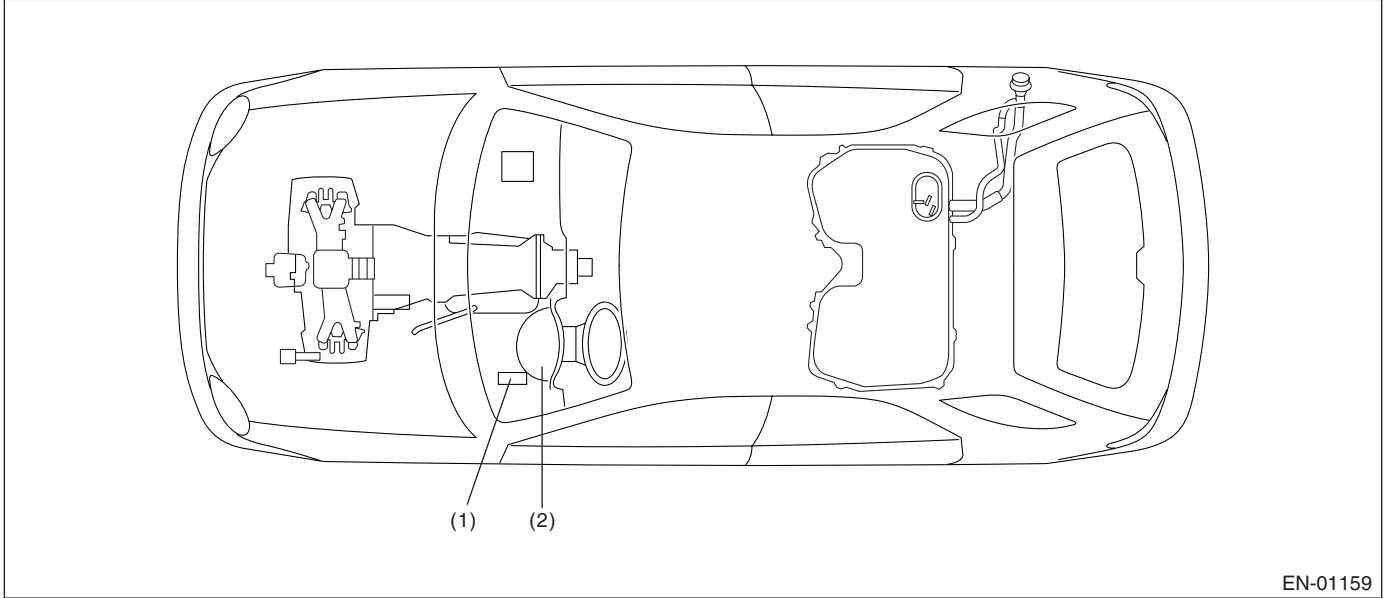

EN-01159

(1) Transmission control module (TCM) (AT model)

(2) AT diagnostic indicator light (AT model)

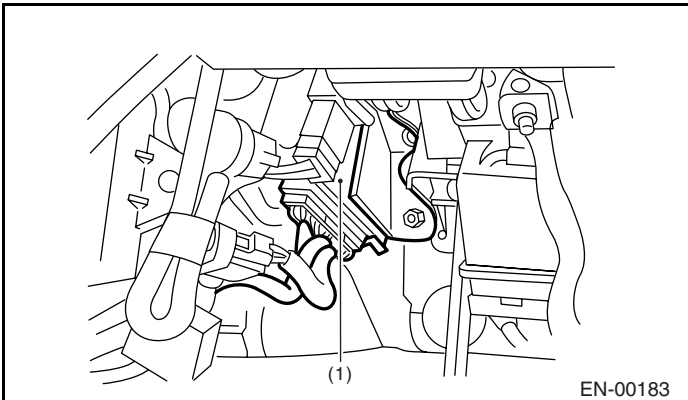

EN-00183

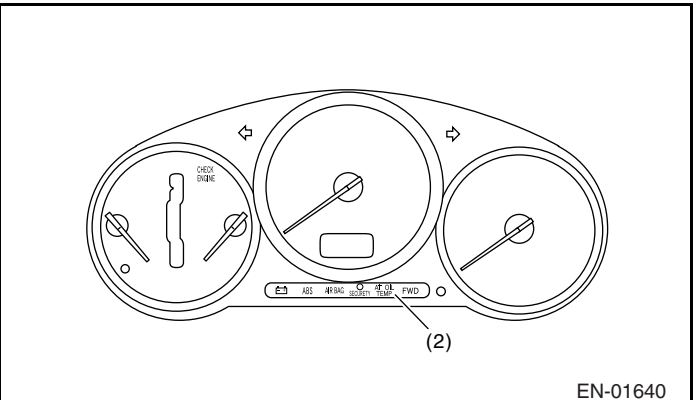

EN-01640

• SENSOR

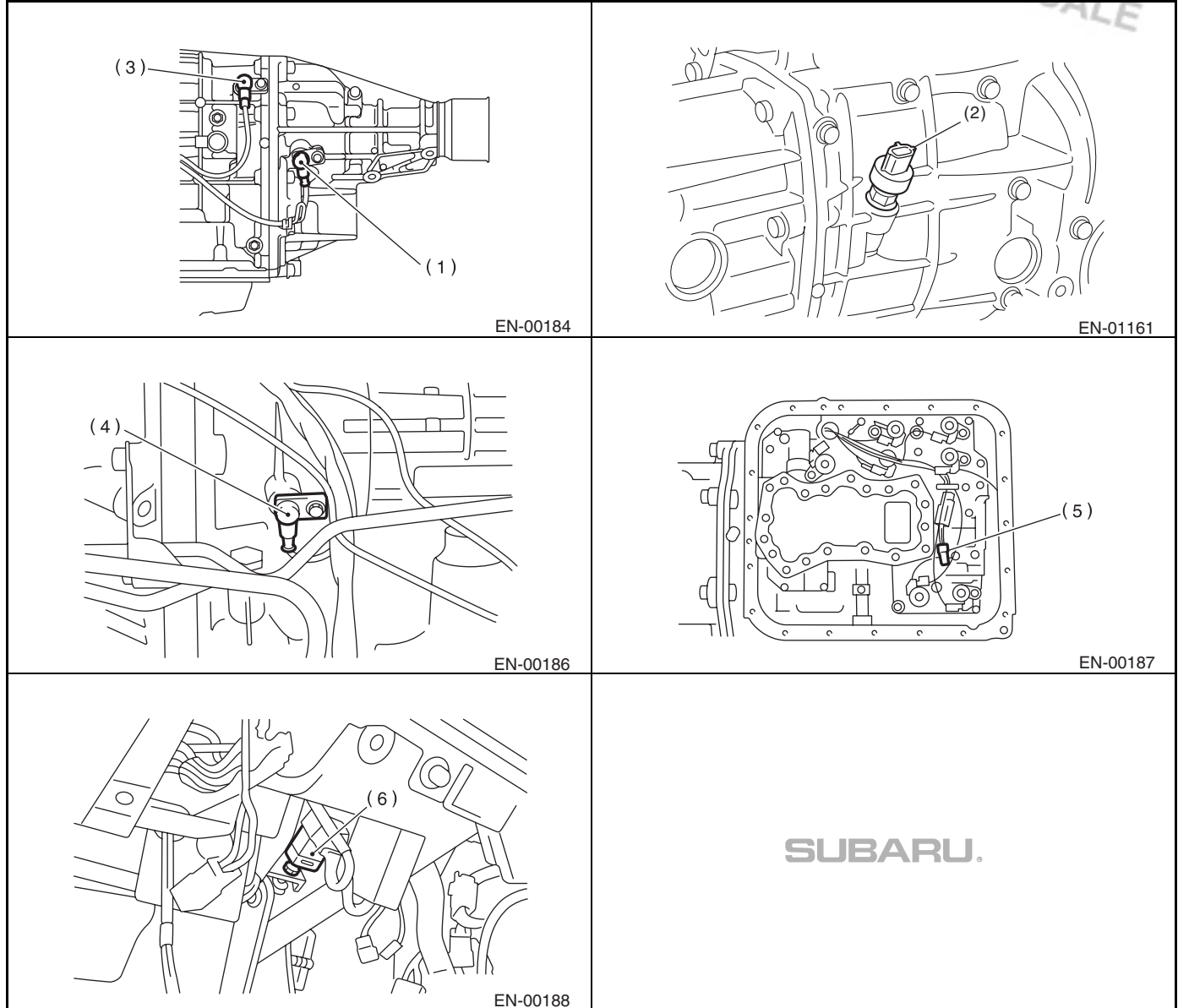

- (1) Rear vehicle speed sensor (AT model)
- (2) Front vehicle speed sensor (MT model)

- (3) Front vehicle speed sensor (AT model)
- (4) Torque converter turbine speed sensor

- (5) ATF temperature sensor (AT model)
- (6) Brake light switch

Electrical Components Location

ENGINE (DIAGNOSTICS)

• SOLENOID VALVE AND SWITCH (AT MODELS)

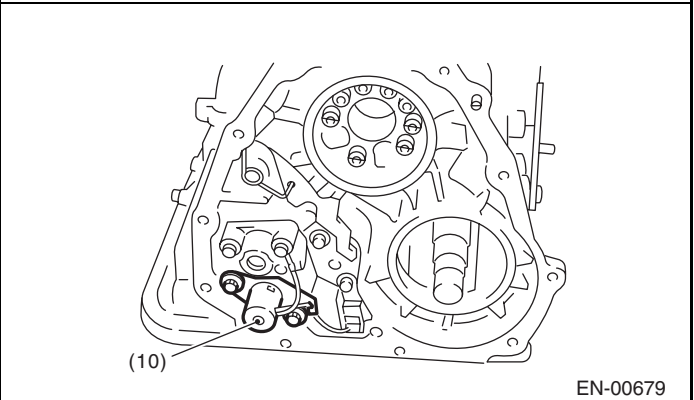
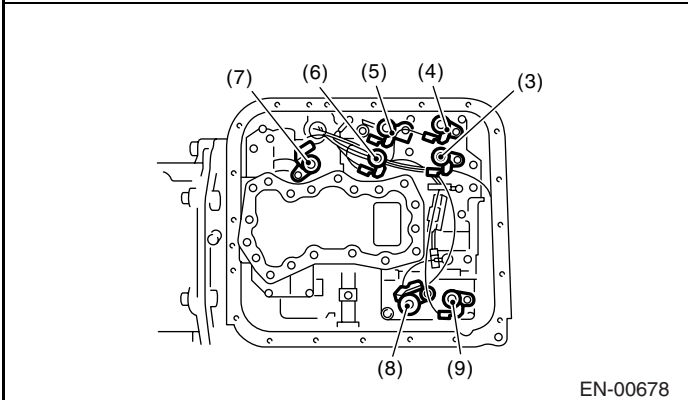
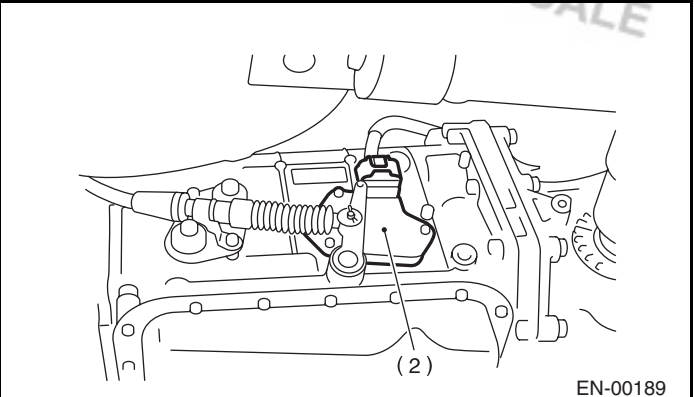
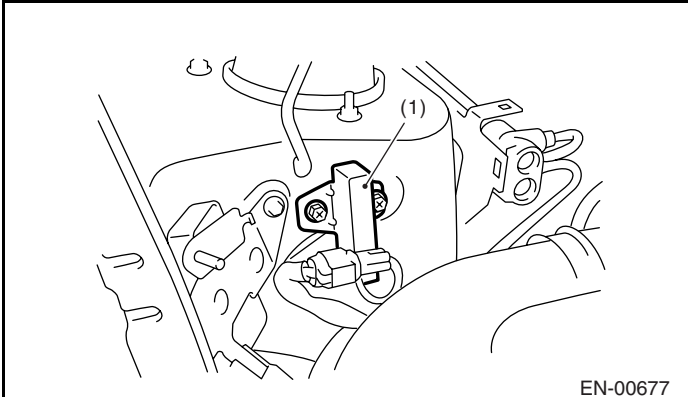

- | | | |
|----------------------------|--------------------------------------|-------------------------------------|
| (1) Dropping resistor | (5) Line pressure duty solenoid | (8) 2-4 brake duty solenoid |
| (2) Inhibitor switch | (6) Low clutch timing solenoid valve | (9) 2-4 brake timing solenoid valve |
| (3) Shift solenoid valve 1 | (7) Lock up duty solenoid | (10) Transfer duty solenoid |
| (4) Shift solenoid valve 2 | | |

• SOLENOID VALVE AND SWITCH (MT MODELS)

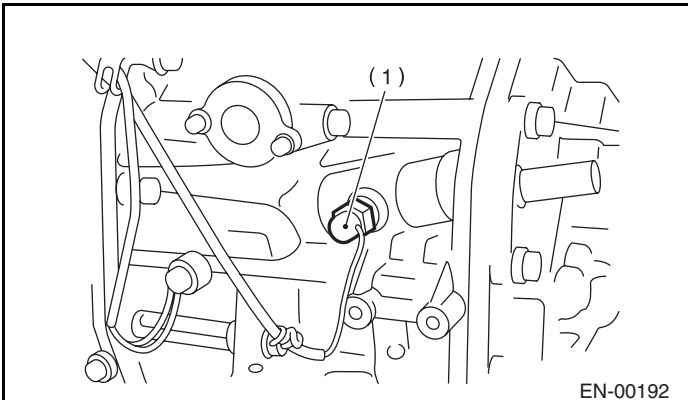

- (1) Neutral position switch

5. Engine Control Module (ECM) I/O Signal

A: ELECTRICAL SPECIFICATION

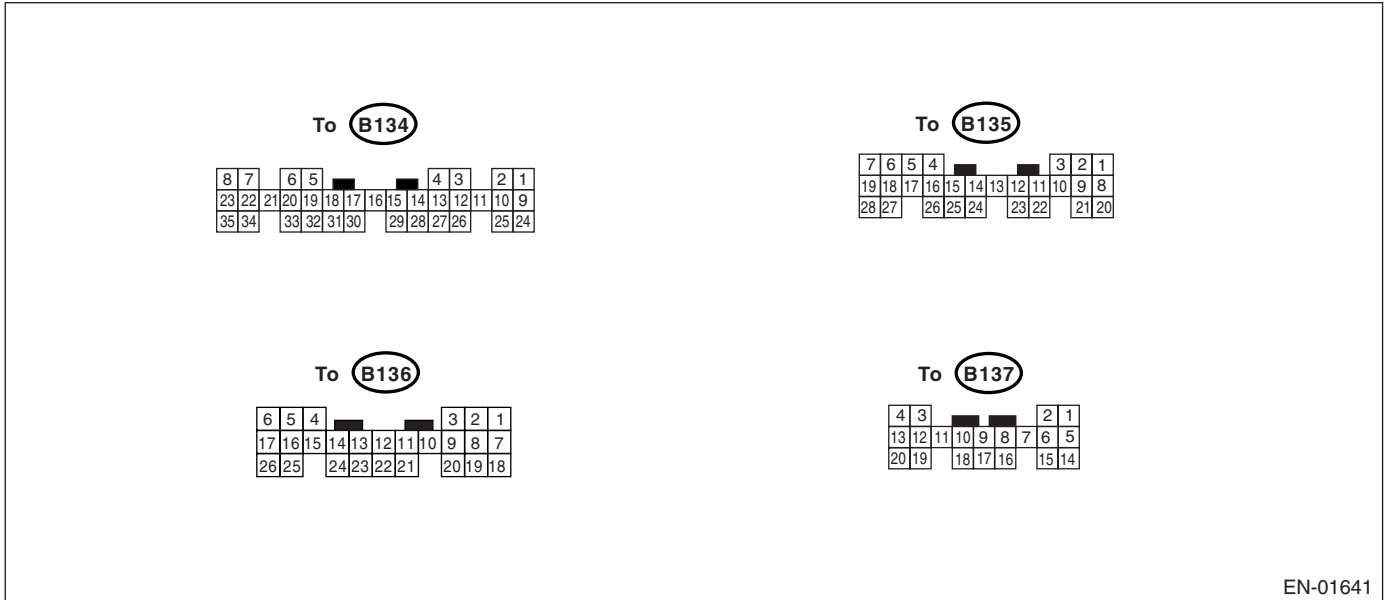

EN-01641

Content	Con- nector No.	Terminal No.	Signal (V)		Note	
			Ignition SW ON (Engine OFF)	Engine ON (Idling)		
Crank- shaft posi- tion sensor	Signal (+)	B135	7	0	-7 to +7	Sensor output waveform
	Signal (-)	B135	17	0	0	—
	Shield	B135	28	0	0	—
Camshaft position sensor	Signal (+)	B135	6	0	-7 to +7	Sensor output waveform
	Signal (-)	B135	18	0	0	—
	Shield	B135	28	0	0	—
Throttle position sensor	Signal	B135	13	Fully closed: 0.2 — 1.0 Fully opened: 4.2 — 4.7		—
	Power supply	B135	3	5	5	—
	GND (sensor)	B135	19	0	0	—
Rear oxy- gen sen- sor	Signal	B135	14	0	0 — 0.9	—
	Shield	B137	15	0	0	—
	GND (sensor)	B135	19	0	0	—
Front oxy- gen (A/F) sensor heater	Signal 1	B136	6	0 — 1.0	0 — 1.0	—
	Signal 2	B136	17	0 — 1.0	0 — 1.0	—
Rear oxygen sensor heater signal	B136	4	0 — 1.0	0 — 1.0	—	
Engine coolant tempera- ture sen- sor	Signal	B135	12	1.0 — 1.4	1.0 — 1.4	After warm-up the engine.
	GND (sensor)	B135	19	0	0	After warm-up the engine.
Vehicle speed signal	B137	10	0 or 5	0 or 5	“5” and “0” are repeatedly dis- played when vehicle is driven.	
Starter switch	B136	20	0	0	Cranking: 8 — 14	

Engine Control Module (ECM) I/O Signal

ENGINE (DIAGNOSTICS)

Content		Con- nector No.	Terminal No.	Signal (V)		Note
				Ignition SW ON (Engine OFF)	Engine ON (Idling)	
A/C switch		B136	11	ON: 10 — 13 OFF: 0	ON: 13 — 14 OFF: 0	—
Ignition switch		B136	10	10 — 13	13 — 14	—
Neutral position switch	MT	B136	21	ON: 12±0.5 OFF: 0		Switch is ON when gear is in neutral position.
	AT	B136	21	ON: 0 OFF: 12±0.5		Switch is ON when shift is in "N" or "P" position.
Test mode connector		B136	3	5	5	When connected: 0
Knock sensor	Signal	B135	16	2.8	2.8	—
	Shield	B135	27	0	0	—
Back-up power supply		B135	9	10 — 13	13 — 14	Ignition switch "OFF": 10 — 13
Control unit power sup- ply		B135	1	10 — 13	13 — 14	—
		B135	2	10 — 13	13 — 14	—
Sensor power supply		B135	3	5	5	—
Ignition control	#1, #2	B134	33	0	1 — 3.4	Waveform
	#3, #4	B134	32	0	1 — 3.4	Waveform
Fuel injec- tor	#1	B134	34	10 — 13	1 — 14	Waveform
	#2	B134	23	10 — 13	1 — 14	Waveform
	#3	B134	22	10 — 13	1 — 14	Waveform
	#4	B134	8	10 — 13	1 — 14	Waveform
Idle air control solenoid valve	Signal 1	B134	20	—	1 — 13	Waveform
	Signal 2	B134	6	—	1 — 13	Waveform
	Signal 3	B134	5	—	1 — 13	Waveform
	Signal 4	B134	19	—	1 — 13	Waveform
Fuel pump relay control		B134	11	ON: 0.5 or less OFF: 10 — 13	0.5 or less	—
A/C relay control		B134	9	ON: 0.5 or less OFF: 10 — 13	ON: 0.5 or less OFF: 13 — 14	—
Radiator main fan relay control		B134	14	ON: 0.5 or less OFF: 10 — 13	ON: 0.5 or less OFF: 13 — 14	—
Radiator sub fan relay control		B134	13	ON: 0.5 or less OFF: 10 — 13	ON: 0.5 or less OFF: 13 — 14	Models with A/C
Self-shutoff control		B136	12	10 — 13	13 — 14	—
Malfunction indicator light		B134	28	—	—	Light "ON": 1 or less Light "OFF": 10 — 14
Engine speed output		B134	10	—	0 — 13, or more	Waveform
Torque control 1 signal		B136	1	5	5	—
Torque control 2 signal		B136	18	5	5	—
Torque control cut sig- nal		B136	15	8	8	—
Purge control solenoid valve		B134	29	ON: 1 or less OFF: 10 — 13	ON: 1 or less OFF: 13 — 14	—
Air assisted injector solenoid valve		B134	12	ON: 1 or less OFF: 10 — 13	ON: 1 or less OFF: 13 — 14	—
Power steering switch		B136	9	ON: 1 or less OFF: 10 — 13	ON: 1 or less OFF: 13 — 14	—
Fuel tank sensor control valve		B134	1	ON: 1 or less OFF: 10 — 13	ON: 1 or less OFF: 10 — 13	—
Fuel temperature sen- sor		B137	5	2.5 — 3.8	2.5 — 3.8	Ambient temperature: 25°C (75°F)
Fuel level sensor		B135	25	0.12 — 4.75	0.12 — 4.75	—

Engine Control Module (ECM) I/O Signal

ENGINE (DIAGNOSTICS)

Content		Con- nector No.	Terminal No.	Signal (V)		Note
				Ignition SW ON (Engine OFF)	Engine ON (Idling)	
Fuel tank pressure sensor	Signal	B135	26	2.3 — 2.7	2.3 — 2.7	The valve obtained after the fuel filler cap was removed once and recapped.
	Power supply	B135	3	5	5	—
	GND (sensor)	B135	19	0	0	—
Pressure control sole-noid valve		B134	4	ON: 1 or less OFF: 10 — 13	ON: 1 or less OFF: 13 — 14	—
Drain valve		B134	3	ON: 1 or less OFF: 10 — 13	ON: 1 or less OFF: 13 — 14	—
AT diagnosis input sig-nal		B137	19	Less than 1 ↔ More than 4	Less than 1 ↔ More than 4	Waveform
Small light switch		B137	20	ON: 0 OFF: 10 — 13	ON: 0 OFF: 13 — 14	—
Blower fan switch		B137	13	ON: 0 OFF: 10 — 13	ON: 0 OFF: 13 — 14	—
Rear defogger switch		B137	4	ON: 0 OFF: 10 — 13	ON: 0 OFF: 13 — 14	—
Front oxygen (A/F) sen-sor signal 1		B136	13	—	2.05 — 2.25	—
Front oxygen (A/F) sen-sor signal 2		B136	22	—	1.75 — 1.95	—
Front oxygen (A/F) sen-sor shield		B135	23	0	0	—
Manifold absolute pres-sure sensor		B135	15	4.0 — 4.8	1.1 — 1.9	—
Intake air temperature sensor		B137	6	3.15 — 3.33	3.15 — 3.33	Intake air temperature: 25°C (75°F)
SSM/GST communica-tion line		B137	16	Less than 1 ↔ More than 4	Less than 1 ↔ More than 4	—
GND (sensors)		B135	19	0	0	—
GND (injectors)		B134	35	0	0	—
GND (ignition system)		B136	26	0	0	—
GND (power supply)		B134	7	0	0	—
GND (control systems)		B137	14	0	0	—
		B135	21	0	0	—
GND (oxygen sensor heater 1)		B136	5	0	0	—
GND (oxygen sensor heater 2)		B136	16	0	0	—

6. Engine Condition Data

A: ELECTRICAL SPECIFICATION

Content	Specified data
Engine load	1.6 — 2.9 (%): Idling
	6.4 — 12.8 (%): 2,500 rpm racing

Measuring condition:

- After the engine is warmed-up.
- Gear position is in “N” or “P” range.
- A/C is turned OFF.
- All accessory switches are turned OFF.

7. Transmission Control Module (TCM) I/O Signal

A: ELECTRICAL SPECIFICATION

For electrical specification of TCM I/O signal, refer to 4AT section. <Ref. to 4AT(diag)-11, ELECTRICAL SPECIFICATION, Transmission Control Module (TCM) I/O Signal.>

*Brought to you by Eris Studios
NOT FOR RESALE*

8. Data Link Connector

A: NOTE

This connector is used both for OBD-II general scan tools and the Subaru Select Monitor.

CAUTION:

Do not connect any scan tools other than the OBD-II general scan tools and the Subaru Select Monitor, because the circuit for the Subaru Select Monitor may be damaged.

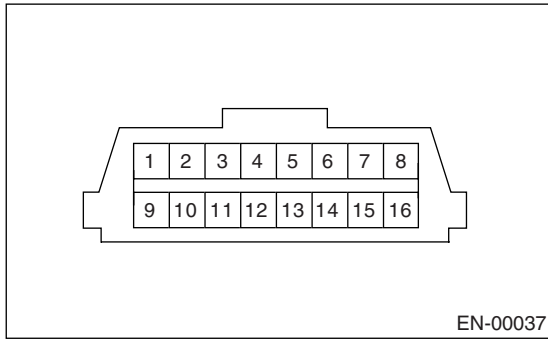

Terminal No.	Contents	Terminal No.	Contents
1	Power supply	9	Blank
2	Blank	10	Subaru Select Monitor signal
3	Blank	11	Blank
4	Blank	12	Ground
5	Blank	13	Ground
6	Test mode check signal 1	14	Blank
7	Blank	15	Blank
8	Test mode check signal 2	16	Blank

9. OBD-II General Scan Tool

A: OPERATION

1. HOW TO USE OBD-II GENERAL SCAN TOOL

- 1) Prepare a general scan tool (OBD-II general scan tool) required by SAE J1978.
- 2) Open the cover and connect the OBD-II general scan tool to data link connector located in the lower portion of instrument panel (on the driver's side).

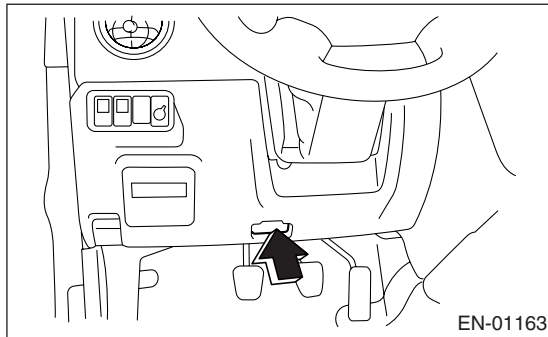

- 3) Using the OBD-II general scan tool, call up DTC and freeze frame data.

OBD-II general scan tool functions consist of:

- (1) MODE \$01: Current powertrain diagnostic data
- (2) MODE \$02: Powertrain freeze frame data
- (3) MODE \$03: Emission-related powertrain DTC
- (4) MODE \$04: Clear/Reset emission-related diagnostic information
- (5) MODE \$06: Request on-board monitoring test results for non-continuously monitored systems
- (6) MODE \$07: Request on-board monitoring test results for continuously monitored systems
- (7) MODE \$09: Request vehicle information

Read out the data according to repair procedures. (For detailed operation procedures, refer to the OBD-II General Scan Tool Operation Manual.)

NOTE:

For details concerning DTC, refer to the List of Diagnostic Trouble Code (DTC). <Ref. to EN(H4SO)(diag)-71, List of Diagnostic Trouble Code (DTC).>

2. MODE \$01 (CURRENT POWERTRAIN DIAGNOSTIC DATA)

Refers to data denoting the current operating condition of analog input/output, digital input/output and/or the powertrain system.

A list of the support data and PID (Parameter Identification) codes are shown in the following table.

PID	Data	Unit of measure
01	Number of emission-related powertrain DTC and malfunction indicator light status and diagnosis support information	—
03	Fuel system control status	—
04	Calculated engine load value	%
05	Engine coolant temperature	°C
06	Short term fuel trim	%
07	Long term fuel trim	%
0B	Intake manifold absolute pressure	kPa
0C	Engine revolution	rpm
0D	Vehicle speed	km/h
0E	Ignition timing advance	°
0F	Intake air temperature	°C
10	Air flow rate from mass air flow sensor	g/sec
11	Throttle valve absolute opening angle	%
13	Check whether oxygen sensor is installed.	—
15	Oxygen sensor output voltage and short term fuel trim associated with oxygen sensor	V and %
1C	Supporting OBD system	—
24	A/F value and A/F sensor output voltage	— and V

NOTE:

Refer to OBD-II general scan tool manufacturer's instruction manual to access generic OBD-II PIDs (MODE \$01).

OBD-II General Scan Tool

ENGINE (DIAGNOSTICS)

3. MODE \$02 (POWERTRAIN FREEZE FRAME DATA)

Refers to data denoting the operating condition when trouble is sensed by the on-board diagnosis system. A list of the support data and PID (Parameter Identification) codes are shown in the following table.

PID	Data	Unit of measure
02	DTC that caused CARB required freeze frame data storage	—
03	Fuel system control status	—
04	Calculated engine load value	%
05	Engine coolant temperature	°C
06	Short term fuel trim	%
07	Long term fuel trim	%
0B	Intake manifold absolute pressure	kPa
0C	Engine revolution	rpm
0D	Vehicle speed	km/h
0E	Ignition timing advance	°
0F	Intake air temperature	°C
10	Air flow rate from mass air flow sensor	g/sec
11	Throttle valve opening angle	%

NOTE:

Refer to OBD-II general scan tool manufacturer's instruction manual to access freeze frame data (MODE \$02).

4. MODE \$03 (EMISSION-RELATED POWERTRAIN DIAGNOSTIC TROUBLE CODE (DTC))

Refer to Read Diagnostic Trouble Code (DTC) for information about data denoting emission-related powertrain DTC. <Ref. to EN(H4SO)(diag)-36, Read Diagnostic Trouble Code (DTC).>

5. MODE \$04 (CLEAR/RESET EMISSION-RELATED DIAGNOSTIC INFORMATION)

Refers to the mode used to clear or reset emission-related diagnostic information (OBD-II trouble diagnostic information).

NOTE:

Refer to OBD-II general scan tool manufacturer's instruction manual to clear or reset emission-related diagnostic information (MODE \$04).

6. MODE \$06

Refer to test value of troubleshooting and data of test limit on support data bit sequence table. List of support data is shown in the following table.

TID	CID	Test value & Test limit	Unit
\$01	\$01	Catalyst system efficiency below threshold	—
\$02	\$81	Exhaust gas recirculation control circuit range/performance	mmHg
	\$02		
\$03	\$81	Evaporative emission control system (CPC open malfunction)	—
	\$02	Evaporative emission control system small leak	pa
	\$03	Evaporative emission control system small leak (Immediate normality judgment)	pa
	\$04	Evaporative emission control system large leak	pa
	\$05	Evaporative emission control system very small leak (Immediate normality judgment)	pa
	\$06	Evaporative emission control system very small leak	pa
\$05	\$01	O ₂ sensor circuit slow response (Bank 1 Sensor 1) Lean → Rich	millisecond
	\$02	O ₂ sensor circuit slow response (Bank 1 Sensor 1) Rich → Lean	
\$06	\$81	O ₂ sensor circuit (Bank 1 Sensor 2) <\$81 or \$02>	V
	\$02		
\$07	\$01	O ₂ sensor circuit slow response (Bank 1 Sensor 2)	second
\$0B	\$81	O ₂ sensor heater circuit (Bank 1 Sensor 2) <\$81 or \$02>	W
	\$02		
\$0C	\$01	Coolant thermostat (Coolant temperature below thermostat regulating temperature)	°C
\$0D	\$01	Evaporative emission control system vent control circuit range/performance	Pa
	\$82		

7. MODE \$07

Refer to data of DTC (pending code) for troubleshooting result about emission in first time.

8. MODE \$09

Refer to data of vehicle specification (VIN, calibration ID, etc.).

10. Subaru Select Monitor

A: OPERATION

1. HOW TO USE SUBARU SELECT MONITOR

1) Prepare the Subaru Select Monitor kit. <Ref. to EN(H4SO)(diag)-8, PREPARATION TOOL, General Description.>

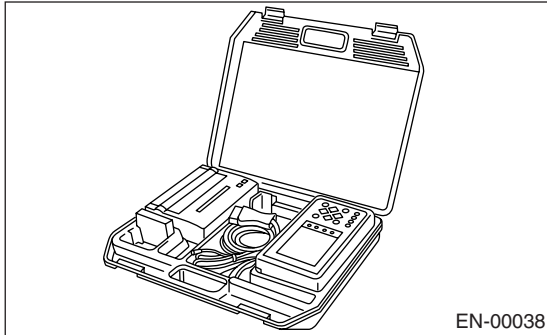

2) Connect the diagnosis cable to Subaru Select Monitor.

3) Insert the cartridge into Subaru Select Monitor. <Ref. to EN(H4SO)(diag)-8, PREPARATION TOOL, General Description.>

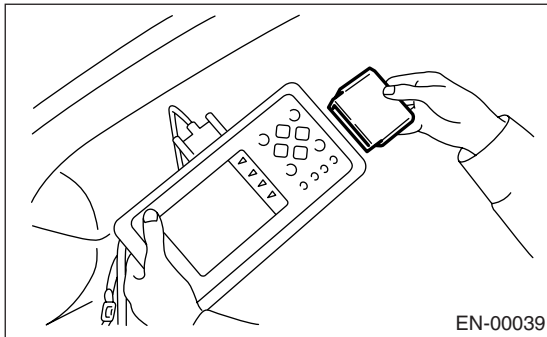

4) Connect the Subaru Select Monitor to data link connector.

(1) Data link connector located in the lower portion of instrument panel (on driver's side).

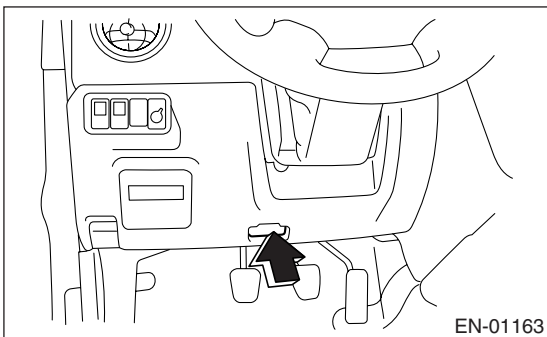

(2) Connect the diagnosis cable to data link connector.

CAUTION:

Do not connect scan tools except for Subaru Select Monitor and OBD-II general scan tool.

5) Turn the ignition switch to ON (engine OFF) and Subaru Select Monitor switch to ON.

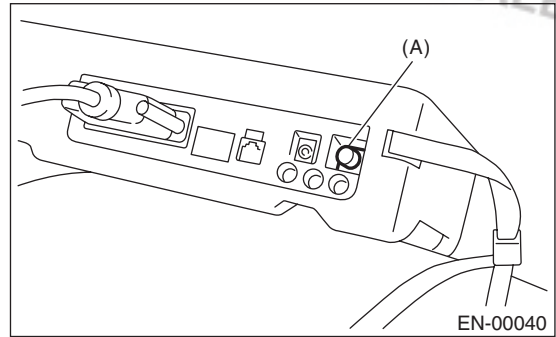

(A) Power switch

6) Using the Subaru Select Monitor, call up DTC and various data, then record them.

2. READ DIAGNOSTIC TROUBLE CODE (DTC) FOR ENGINE (NORMAL MODE)

Refer to Read Diagnostic Trouble Code (DTC) for information about how to indicate DTC. <Ref. to EN(H4SO)(diag)-36, Read Diagnostic Trouble Code (DTC).>

3. READ DIAGNOSTIC TROUBLE CODE (DTC) FOR ENGINE (OBD MODE)

Refer to Read Diagnostic Trouble Code (DTC) for information about how to indicate DTC. <Ref. to EN(H4SO)(diag)-36, Read Diagnostic Trouble Code (DTC).>

4. READ CURRENT DATA FOR ENGINE (NORMAL MODE)

- 1) On «Main Menu» display screen, select the {Each System Check} and press the [YES] key.
 - 2) On «System Selection Menu» display screen, select the {Engine Control System} and press the [YES] key.
 - 3) Press the [YES] key after the information of engine type is displayed.
 - 4) On «Engine Diagnosis» display screen, select the {Current Data Display & Save} and press the [YES] key.
 - 5) On «Data Display Menu» display screen, select the {Data Display} and press the [YES] key.
 - 6) Using the scroll key, move the display screen up or down until the desired data is shown.
- A list of support data is shown in the following table.

Contents	Display	Unit of measure
Battery voltage	Battery Voltage	V
Vehicle speed signal	Vehicle Speed	km/h or MPH
Engine speed signal	Engine Speed	rpm
Engine coolant temperature signal	Coolant Temp.	°C or °F
Ignition timing signal	Ignition Timing	deg
Throttle position signal	Throttle Opening Angle	%
Throttle position signal	Throttle Sensor Voltage	V
Injection pulse width	Fuel Injection #1 Pulse	ms
Idle air control signal	ISC Valve Step	STEP
Engine load data	Engine Load	%
Front oxygen (A/F) sensor output signal	A/F Sensor #1	—
Front oxygen (A/F) sensor resistance	A/F Sensor #1 Resistance	ohm
Rear oxygen sensor output signal	Rear O ₂ Sensor	V
Short term fuel trim	A/F Correction #1	%
Knock sensor signal	Knocking Correction	deg
Atmospheric absolute pressure signal	Atmosphere Pressure	mmHg, kPa, inHg or psi
Intake manifold relative pressure signal	Mani. Relative Pressure	mmHg, kPa, inHg or psi
Intake manifold absolute pressure signal	Mani. Absolute Pressure	mmHg, kPa, inHg or psi
A/F correction (short term fuel trim) by rear oxygen sensor	A/F Correction #3	%
Long term whole fuel trim	A/F Learning #1	%
Front oxygen (A/F) sensor heater current	Front O ₂ Heater #1	A
Rear oxygen sensor heater current	Rear O ₂ Heater Current	A
Canister purge control solenoid valve duty ratio	CPC Valve Duty Ratio	%
Fuel level signal	Fuel Level	V
Fuel temperature signal	Fuel Temp	°C or °F
Fuel tank pressure signal	Fuel Tank Pressure	mmHg or kPa or inHg or psi
Intake air temperature signal	Intake Air Temp.	°C or °F
Learned ignition timing	Learned Ignition Timing	deg
Ignition switch signal	Ignition Switch	ON or OFF
Test mode connector signal	Test Mode Signal	ON or OFF
Neutral position switch signal	Neutral Position Switch	ON or OFF
Air conditioning switch signal	A/C Switch	ON or OFF
Air conditioning signal	A/C Compressor Signal	ON or OFF
Radiator main fan relay signal	Radiator Fan Relay #1	ON or OFF
Fuel pump relay signal	Fuel Pump Relay	ON or OFF
Knocking signal	Knocking Signal	ON or OFF
Radiator sub fan relay signal	Radiator Fan Relay #2	ON or OFF
Power steering switch signal	P/S Switch	ON or OFF
Engine torque control signal #1	Torque Control Signal #1	ON or OFF
Engine torque control signal #2	Torque Control Signal #2	ON or OFF
Engine torque control permission signal	Torque Permission Signal	ON or OFF

Subaru Select Monitor

ENGINE (DIAGNOSTICS)

Contents	Display	Unit of measure
Rear oxygen sensor rich signal	Rear O ₂ Rich Signal	ON or OFF
Starter switch signal	Starter Switch Signal	ON or OFF
Idle switch signal	Idle Switch Signal	ON or OFF
Crankshaft position sensor signal	Crankshaft Position Sig.	ON or OFF
Camshaft position sensor signal	Camshaft Position Sig.	ON or OFF
Rear defogger switch signal	Rear Defogger Switch	ON or OFF
Blower fan switch signal	Blower Fan Switch	ON or OFF
Small light switch signal	Light Switch	ON or OFF
Air assisted injector solenoid valve signal	Assist Air Sol. Valve	ON or OFF
AT/MT identification terminal	AT Model ID Signal	ON or OFF
Pressure control solenoid valve signal	PCV Solenoid Valve	ON or OFF
Vent control solenoid valve signal	Vent. Solenoid Valve	ON or OFF
Fuel tank sensor control valve signal	Tank Sensor Cntl Valve	ON or OFF

NOTE:

For detailed operation procedure, refer to the SUBARU SELECT MONITOR OPERATION MANUAL.

5. READ CURRENT DATA FOR ENGINE (OBD MODE)

- 1) On «Main Menu» display screen, select the {Each System Check} and press the [YES] key.
 - 2) On «System Selection Menu» display screen, select the {Engine Control System} and press the [YES] key.
 - 3) Press the [YES] key after the information of engine type is displayed.
 - 4) On «Engine Diagnosis» display screen, select the {OBD System} and press the [YES] key.
 - 5) On «OBD Menu» display screen, select the {Current Data Display & Save} and press the [YES] key.
 - 6) On «Data Display Menu» display screen, select the {Data Display} and press the [YES] key.
 - 7) Using the scroll key, move the display screen up or down until the desired data is shown.
- A list of support data is shown in the following table.

Contents	Display	Unit of measure
Number of DTC	Number of DTC	—
Malfunction indicator light status	MI (MIL)	ON or OFF
Monitoring test of misfire	Misfire monitoring	Complete or incomplete
Monitoring test of fuel system	Fuel system monitoring	Complete or incomplete
Monitoring test of comprehensive component	Component monitoring	Complete or incomplete
Test of catalytic converter	Catalyst Diagnosis	Complete or incomplete
Test of heated catalytic converter	Heated catalyst	No support
Test of evaporative emission purge control system	Evaporative purge system	Complete or incomplete
Test of secondary air system	Secondary air system	No support
Test of air conditioning system refrigerant	A/C system refrigerant	No support
Test of oxygen sensor	Oxygen sensor	Complete or incomplete
Test of oxygen sensor heater	O ₂ Heater Diagnosis	Complete or incomplete
Test of EGR system	EGR system	No support
Air fuel ratio control system for bank 1	Fuel System for Bank 1	—
Engine load data	Calculated load value	%
Engine coolant temperature signal	Coolant Temp.	°C or °F
Short term fuel trim by front oxygen (A/F) sensor	Short term fuel trim B1	%
Long term fuel trim by front oxygen (A/F) sensor	Long term fuel trim B1	%
Intake manifold absolute pressure signal	Mani. Absolute Pressure	mmHg, kPa, inHg or psi
Engine speed signal	Engine Speed	rpm
Vehicle speed signal	Vehicle Speed	km/h or MPH
Ignition timing advance for #1 cylinder	Ignition timing adv. #1	°
Intake air temperature signal	Intake Air Temp.	°C or °F
Intake air amount	Mass Air Flow	g/s

Subaru Select Monitor

ENGINE (DIAGNOSTICS)

Contents	Display	Unit of measure
Throttle position signal	Throttle Opening Angle	%
Rear oxygen sensor output signal	Oxygen Sensor #12	V
Air fuel ratio correction by rear oxygen sensor	Short term fuel trim #12	%
On-board diagnostic system	OBD System	—
A/F sensor check	A/F sensor	—
A/F sensor #11	A/F sensor #11	—
A/F sensor #11	A/F sensor #11	V

NOTE:

For detailed operation procedure, refer to the SUBARU SELECT MONITOR OPERATION MANUAL.

6. READ FREEZE FRAME DATA FOR ENGINE (OBD MODE)

- 1) On «Main Menu» display screen, select the {Each System Check} and press the [YES] key.
 - 2) On «System Selection Menu» display screen, select the {Engine Control System} and press the [YES] key.
 - 3) Press the [YES] key after the information of engine type is displayed.
 - 4) On «Engine Diagnosis» display screen, select the {OBd System} and press the [YES] key.
 - 5) On «OBd Menu» display screen, select the {Freeze Frame Data} and press the [YES] key.
- A list of support data is shown in the following table.

Contents	Display	Unit of measure
DTC for freeze frame data	Freeze frame data	DTC
Air fuel ratio control system for bank 1	Fuel system for Bank1	ON or OFF
Engine load data	Engine Load	%
Engine coolant temperature signal	Coolant Temp.	°C or °F
Short term fuel trim by front oxygen (A/F) sensor	Short term fuel trim B1	%
Long term fuel trim by front oxygen (A/F) sensor	Long term fuel trim B1	%
Intake manifold absolute pressure signal	Mani. Absolute Pressure	mmHg, kPa, inHg or psi
Engine speed signal	Engine Speed	rpm
Vehicle speed signal	Vehicle Speed	km/h or MPH
Ignition timing signal	Ignition Timing	°
Intake air volume	Mass Air Flow	g/sec
Intake air temperature signal	Intake Air Temp	°C
Throttle position signal	Throttle Opening Angle	%

NOTE:

For detailed operation procedure, refer to the SUBARU SELECT MONITOR OPERATION MANUAL.

Subaru Select Monitor

ENGINE (DIAGNOSTICS)

7. LED OPERATION MODE FOR ENGINE

- 1) On «Main Menu» display screen, select the {Each System Check} and press the [YES] key.
 - 2) On «System Selection Menu» display screen, select the {Engine Control System} and press the [YES] key.
 - 3) Press the [YES] key after the information of engine type is displayed.
 - 4) On «Engine Diagnosis» display screen, select the {Current Data Display & Save} and press the [YES] key.
 - 5) On «Data Display Menu» display screen, select the {Data & LED Display} and press the [YES] key.
 - 6) Using the scroll key, move the display screen up or down until the desired data is shown.
- A list of support data is shown in the following table.

Contents	Display	Message	LED "ON" requirements
Ignition switch signal	Ignition Switch	ON or OFF	When ignition switch is turned ON.
Test mode connector signal	Test Mode Signal	ON or OFF	When test mode connector is connected.
Neutral position switch signal	Neutral Position Switch	ON or OFF	When neutral position signal is entered.
Air conditioning switch signal	A/C Switch	ON or OFF	When air conditioning switch is turned ON.
Air conditioning relay signal	A/C Relay	ON or OFF	When air conditioning relay is in function.
Radiator main fan relay signal	Radiator Fan Relay #1	ON or OFF	When radiator main fan relay is in function.
Fuel pump relay signal	Fuel Pump Relay	ON or OFF	When fuel pump relay is in function.
Knocking signal	Knocking Signal	ON or OFF	When knocking signal is entered.
Radiator sub fan relay signal	Radiator Fan Relay #2	ON or OFF	When radiator sub fan relay is in function.
Engine torque control signal #1	Torque Control Signal #1	ON or OFF	When engine torque control signal 1 is entered.
Engine torque control signal #2	Torque Control Signal #2	ON or OFF	When engine torque control signal 2 is entered.
Engine torque control permission signal	Torque Control Permit	ON or OFF	When engine torque control permission signal is entered.
Rear oxygen sensor rich signal	Rear O ₂ Rich Signal	ON or OFF	When rear oxygen sensor mixture ratio is rich.
Starter switch signal	Starter Switch Signal	ON or OFF	When starter switch signal is entered.
Idle switch signal	Idle Switch Signal	ON or OFF	When idle switch signal is entered.
Crankshaft position sensor signal	Crankshaft Position Sig.	ON or OFF	When crankshaft position sensor signal is entered.
Camshaft position sensor signal	Camshaft Position Sig.	ON or OFF	When camshaft position sensor signal is entered.
Power steering switch signal	P/S Switch	ON or OFF	When power steering switch signal is entered.
Rear defogger switch signal	Rear Defogger Switch	ON or OFF	When rear defogger switch is turned ON.
Blower fan switch signal	Blower Fan Switch	ON or OFF	When blower fan switch is turned ON.
Small light switch signal	Light Switch	ON or OFF	When small light switch is turned ON.
Air assist injector solenoid valve signal	Assist Air Sol. Valve	ON or OFF	When air assist injector solenoid valve signal is input.
AT/MT identification terminal	AT Model ID Signal	ON or OFF	ON when vehicle is AT.
Pressure control solenoid valve signal	PCV Solenoid Valve	ON or OFF	When pressure control valve signal is entered.
Vent control solenoid valve signal	Vent Solenoid Valve	ON or OFF	When vent control valve signal is entered.
Fuel tank sensor control valve signal	Tank Sensor Cntl Valve	ON or OFF	When fuel tank sensor control signal entered.

NOTE:

For detailed operation procedure, refer to the SUBARU SELECT MONITOR OPERATION MANUAL.

8. READ CURRENT DATA FOR AT

- 1) On «Main Menu» display screen, select the {Each System Check} and press the [YES] key.
- 2) On «System Selection Menu» display screen, select the {Transmission Control System} and press the [YES] key.
- 3) Press the [YES] key after the information of transmission type is displayed.
- 4) On «Transmission Diagnosis» display screen, select the {Current Data Display & Save} and press the [YES] key.
- 5) On «Data Display Menu» display screen, select the {Data Display} and press the [YES] key.
- 6) Using the scroll key, move the display screen up or down until the desired data is shown.
 - A list of support data is shown in the following table.

Contents	Display	Unit of measure
Battery voltage	Battery Voltage	V
Rear vehicle speed sensor signal	Vehicle Speed #1	km/h or MPH
Front vehicle speed sensor signal	Vehicle Speed #2	km/h or MPH
Engine speed signal	Engine Speed	rpm
Automatic transmission fluid temperature signal	ATF Temp.	°C or °F
Throttle position signal	Throttle Sensor Voltage	V
Gear position	Gear Position	—
Line pressure control duty ratio	Line Pressure Duty Ratio	%
Lock up clutch control duty ratio	Lock Up Duty Ratio	%
Transfer clutch control duty ratio	Transfer Duty Ratio	%
Power supply for throttle position sensor	Throttle Sensor Power	V
Torque converter turbine speed signal	AT Turbine Speed	rpm
2-4 brake timing pressure control duty ratio	2-4B Duty Ratio	%
Manifold absolute pressure sensor voltage	Mani. Pressure Voltage	V
2 wheel drive switch signal	2WD Switch	ON or OFF
Kick down switch signal	Kick Down Switch	ON or OFF
Stop light switch signal	Stop light Switch	ON or OFF
Anti lock brake system signal	ABS Signal	ON or OFF
Cruise control system signal	Cruise Control Signal	ON or OFF
Neutral/Parking range signal	N/P Range Signal	ON or OFF
Reverse range signal	R Range Signal	ON or OFF
Drive range signal	D Range Signal	ON or OFF
3rd range signal	3rd Range Signal	ON or OFF
2nd range signal	2nd Range Signal	ON or OFF
1st range signal	1st Range Signal	ON or OFF
Shift control solenoid A	Shift Solenoid #1	ON or OFF
Shift control solenoid B	Shift Solenoid #2	ON or OFF
Torque control output signal #1	Torque Control Signal #1	ON or OFF
Torque control output signal #2	Torque Control Signal #2	ON or OFF
Torque control cut signal	Torque Control Cut Sig.	ON or OFF
2-4 brake timing control solenoid valve	2-4 Brake Timing Sol.	ON or OFF
Low clutch timing control solenoid valve	Low Clutch Timing Sol.	ON or OFF
Automatic transmission diagnosis indicator light	AT Diagnosis light	ON or OFF

NOTE:

For detailed operation procedure, refer to the SUBARU SELECT MONITOR OPERATION MANUAL.

11. Read Diagnostic Trouble Code (DTC)

A: OPERATION

1. SUBARU SELECT MONITOR (NORMAL MODE)

- 1) On «Main Menu» display screen, select the {Each System Check} and press the [YES] key.
- 2) On «System Selection Menu» display screen, select the {Engine Control System} and press the [YES] key.
- 3) Press the [YES] key after the information of engine type is displayed.
- 4) On «Engine Diagnosis» display screen, select the {Diagnostic Code(s) Display} and press the [YES] key.
- 5) On «Diagnostic Code(s) Display» display screen, select the {Current Diagnostic Code(s)} or {History Diagnostic Code(s)} and press the [YES] key.

NOTE:

- For detailed operation procedure, refer to SUBARU SELECT MONITOR OPERATION MANUAL.
- For details concerning DTC, refer to the List of Diagnostic Trouble Code (DTC). <Ref. to EN(H4SO)(diag)-71, List of Diagnostic Trouble Code (DTC).>

2. SUBARU SELECT MONITOR (OBD MODE)

- 1) On «Main Menu» display screen, select the {2. Each System Check} and press the [YES] key.
- 2) On «System Selection Menu» display screen, select the {Engine Control System} and press the [YES] key.
- 3) Press the [YES] key after the information of engine type is displayed.
- 4) On «Engine Diagnosis» display screen, select the {OBD System} and press the [YES] key.
- 5) On «OBD Menu» display screen, select the {Diagnosis Code(s) Display} and press the [YES] key.
- 6) Make sure that a DTC is shown on display screen.

NOTE:

- For detailed operation procedure, refer to SUBARU SELECT MONITOR OPERATION MANUAL.
- For details concerning DTC, refer to the List of Diagnostic Trouble Code (DTC). <Ref. to EN(H4SO)(diag)-71, List of Diagnostic Trouble Code (DTC).>

3. OBD-II GENERAL SCAN TOOL

Refers to data denoting emission-related powertrain DTC.

For details concerning DTC, refer to the List of Diagnostic Trouble Code (DTC). <Ref. to EN(H4SO)(diag)-71, List of Diagnostic Trouble Code (DTC).>

NOTE:

Refer to OBD-II general scan tool manufacturer's instruction manual to access emission-related powertrain DTC (MODE \$03).

12. Inspection Mode

A: OPERATION

Carry out trouble diagnosis shown in the following DTC table.

When performing trouble diagnosis which is not shown in the DTC table, refer to the next item Drive cycle.

<Ref. to EN(H4SO)(diag)-42, Drive Cycle.>

DTC	Item
P0030	HO2S Heater Control Circuit (Bank 1 Sensor 1)
P0031	HO2S Heater Control Circuit Low (Bank 1 Sensor 1)
P0032	HO2S Heater Control Circuit High (Bank 1 Sensor 1)
P0037	HO2S Heater Control Circuit Low (Bank 1 Sensor 2)
P0038	HO2S Heater Control Circuit High (Bank 1 Sensor 2)
P0066	Air Assisted Injector Control Circuit or Circuit Low
P0068	Manifold Absolute Pressure/Barometric Pressure Circuit Range/Performance Problem
P0107	Manifold Absolute Pressure/Barometric Pressure Circuit Low Input
P0108	Manifold Absolute Pressure/Barometric Pressure Circuit High Input
P0112	Intake Air Temperature Circuit Low Input
P0113	Intake Air Temperature Circuit High Input
P0117	Engine Coolant Temperature Circuit Low Input
P0118	Engine Coolant Temperature Circuit High Input
P0122	Throttle/Pedal Position Sensor/Switch "A" Circuit Low Input
P0123	Throttle/Pedal Position Sensor/Switch "A" Circuit High Input
P0129	Atmospheric Pressure Sensor Circuit Range/Performance
P0130	O ₂ Sensor Circuit (Bank 1 Sensor 1)
P0131	O ₂ Sensor Circuit Low Voltage (Bank 1 Sensor 1)
P0132	O ₂ Sensor Circuit High Voltage (Bank 1 Sensor 1)
P0134	O ₂ Sensor Circuit No Activity Detected (Bank 1 Sensor 1)
P0137	O ₂ Sensor Circuit Low Voltage (Bank 1 Sensor 2)
P0138	O ₂ Sensor Circuit High Voltage (Bank 1 Sensor 2)
P0182	Fuel Temperature Sensor "A" Circuit Low Input
P0183	Fuel Temperature Sensor "A" Circuit High Input
P0327	Knock Sensor 1 Circuit Low Input (Bank 1 or Single Sensor)
P0328	Knock Sensor 1 Circuit High Input (Bank 1 or Single Sensor)
P0335	Crankshaft Position Sensor "A" Circuit
P0336	Crankshaft Position Sensor "A" Circuit Range/Performance
P0340	Camshaft Position Sensor "A" Circuit (Bank 1 or Single Sensor)
P0341	Camshaft Position Sensor "A" Circuit Range/Performance (Bank 1 or Single Sensor)
P0447	Evaporative Emission Control System Vent Control Circuit Open
P0448	Evaporative Emission Control System Vent Control Circuit Shorted
P0452	Evaporative Emission Control System Pressure Sensor Low Input
P0453	Evaporative Emission Control System Pressure Sensor High Input
P0458	Evaporative Emission Control System Purge Control Valve Circuit Low
P0462	Fuel Level Sensor Circuit Low Input
P0463	Fuel Level Sensor Circuit High Input
P0502	Vehicle Speed Sensor Circuit Low Input
P0503	Vehicle Speed Sensor Intermittent/Erratic/High
P0512	Starter Request Circuit
P0519	Idle Control System Malfunction (Fail-Safe)
P0565	Cruise Control On Signal
P0604	Internal Control Module Random Access Memory (RAM) Error
P0691	Cooling Fan 1 Control Circuit Low
P0703	Torque Converter/Brake Switch "B" Circuit

Inspection Mode

ENGINE (DIAGNOSTICS)

DTC	Item
P0705	Transmission Range Sensor Circuit (PRNDL Input)
P0710	Transmission Fluid Temperature Sensor Circuit
P0716	Torque Converter Turbine Speed Sensor
P0720	Output Speed Sensor Circuit
P0726	Engine Speed Input Circuit Range/Performance
P0731	Gear 1 Incorrect Ratio
P0732	Gear 2 Incorrect Ratio
P0733	Gear 3 Incorrect Ratio
P0734	Gear 4 Incorrect Ratio
P0741	Torque Converter Clutch Circuit Performance or Stuck Off
P0743	Torque Converter Clutch Circuit Electrical
P0748	Pressure Control Solenoid "A" Electrical
P0753	Shift Solenoid "A" Electrical
P0758	Shift Solenoid "B" Electrical
P0771	Low Clutch Timing Solenoid
P0778	Pressure Control Solenoid "B" Electrical
P0785	Shift/Timing Solenoid
P0851	Neutral Switch Input Circuit Low
P0852	Neutral Switch Input Circuit High
P0864	TCM Communication Circuit Range/Performance
P0865	TCM Communication Circuit Low
P0866	TCM Communication Circuit High
P1110	Atmospheric Pressure Sensor Circuit Malfunction (Low Input)
P1111	Atmospheric Pressure Sensor Circuit Malfunction (High Input)
P1134	A/F Sensor Micro-computer Problem
P1400	Fuel Tank Pressure Control Solenoid Valve Circuit Low
P1420	Fuel Tank Pressure Control Solenoid Valve Circuit High
P1446	Fuel Tank Sensor Control Valve Circuit Low
P1447	Fuel Tank Sensor Control Valve Circuit High
P1510	ISC Solenoid Valve Signal #1 Circuit Malfunction (Low Input)
P1511	ISC Solenoid Valve Signal #1 Circuit Malfunction (High Input)
P1512	ISC Solenoid Valve Signal #2 Circuit Malfunction (Low Input)
P1513	ISC Solenoid Valve Signal #2 Circuit Malfunction (High Input)
P1514	ISC Solenoid Valve Signal #3 Circuit Malfunction (Low Input)
P1515	ISC Solenoid Valve Signal #3 Circuit Malfunction (High Input)
P1516	ISC Solenoid Valve Signal #4 Circuit Malfunction (Low Input)
P1517	ISC Solenoid Valve Signal #4 Circuit Malfunction (High Input)
P1518	Starter Switch Circuit Low Input
P1560	Back-up Voltage Circuit Malfunction
P1698	Engine Torque Control Cut Signal Circuit Low Input
P1699	Engine Torque Control Cut Signal Circuit High Input
P1700	Throttle Position Sensor
P1711	Engine Torque Control Signal 1 Circuit Malfunction
P1712	Engine Torque Control Signal 2 Circuit Malfunction

1. PREPARATION FOR THE INSPECTION MODE

- 1) Make sure the fuel remains approx. half amount [20 — 40 ℓ (5.3 — 10.6 US gal, 4.4 — 8.8 Imp gal)] and the battery voltage is 12 V or more.
- 2) Raise the vehicle using a garage jack and place on safety stands or drive the vehicle onto free rollers.

WARNING:

- Before raising the vehicle, ensure the parking brake is applied.
- Do not use a pantograph jack in place of a safety stand.
- Secure a rope or wire to the front and rear towing or tie-down hooks to prevent the lateral runout of front wheels.
- Do not abruptly depress/release the clutch pedal or accelerator pedal during works even when engine is operating at low speeds since this may cause vehicle to jump off free rollers.
- In order to prevent the vehicle from slipping due to vibration, do not place any wooden blocks or similar items between the safety stands and the vehicle.
- Since the rear wheels will also rotate, do not place anything near them. Also, make sure nobody goes in front of the vehicle.

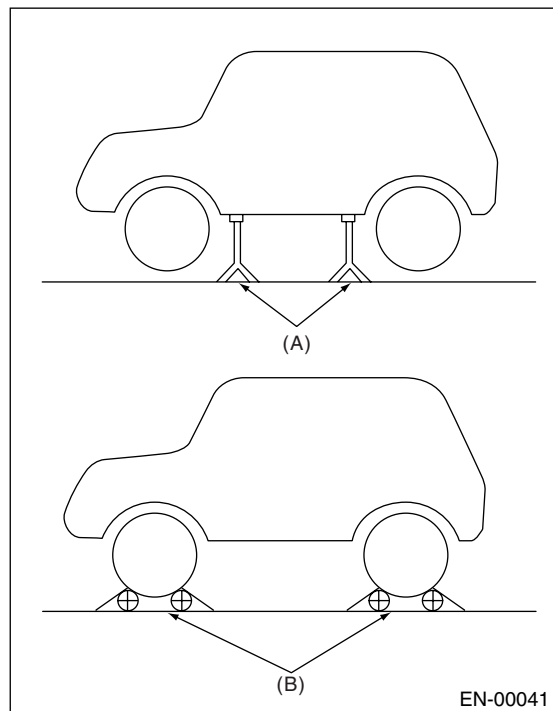

- (A) Safety stand
(B) Free rollers

2. SUBARU SELECT MONITOR

- 1) After clearing the memory, check for any remaining unresolved trouble data. <Ref. to EN(H4SO)(diag)-44, Clear Memory Mode.>
- 2) Warm up the engine.
- 3) Prepare the Subaru Select Monitor kit. <Ref. to EN(H4SO)(diag)-8, PREPARATION TOOL, General Description.>



EN-00038

- 4) Connect the diagnosis cable to Subaru Select Monitor.
- 5) Insert the cartridge into Subaru Select Monitor. <Ref. to EN(H4SO)(diag)-8, PREPARATION TOOL, General Description.>

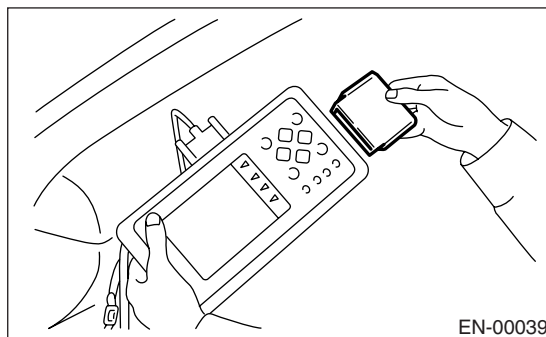

EN-00039

- 6) Connect the test mode connector (A) at the lower portion of instrument panel (on driver's side).

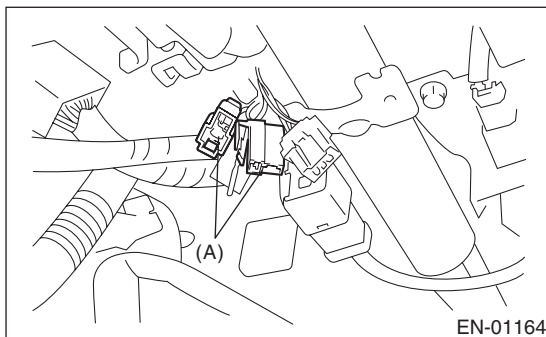

EN-01164

- 7) Connect the Subaru Select Monitor to data link connector.

Inspection Mode

ENGINE (DIAGNOSTICS)

(1) Data link connector is located in the lower portion of the instrument panel (on the driver's side).

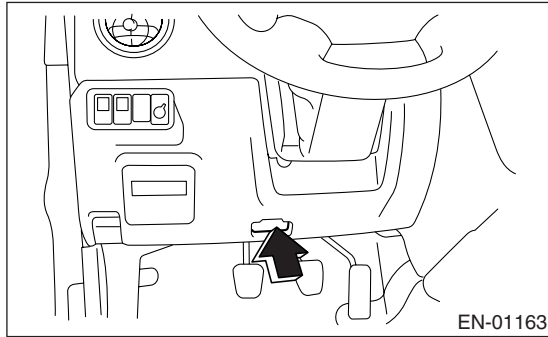

(2) Connect the diagnosis cable to data link connector.

CAUTION:

Do not connect the scan tools except for Subaru Select Monitor and OBD-II general scan tool.

8) Turn the ignition switch to ON (engine OFF) and Subaru Select Monitor switch to ON.

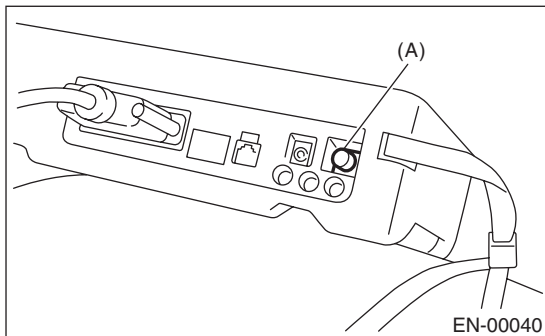

(A) Power switch

9) On «Main Menu» display screen, select the {2. Each System Check} and press the [YES] key.

10) On «System Selection Menu» display screen, select the {Engine Control System} and press the [YES] key.

11) Press the [YES] key after the information of engine type is displayed.

12) On «Engine Diagnosis» display screen, select the {Dealer Check Mode Procedure} and press the [YES] key.

13) When the "Perform Inspection (Dealer Check) Mode?" is shown on display screen, press the [YES] key.

14) Perform subsequent procedures as instructed on display screen.

- If trouble still remains in memory, the corresponding DTC appears on display screen.

NOTE:

- For detailed operation procedure, refer to the SUBARU SELECT MONITOR OPERATION MANUAL.

- For details concerning the DTC, refer to the List of Diagnostic Trouble Code (DTC).

<Ref. to EN(H4SO)(diag)-71, List of Diagnostic Trouble Code (DTC).>

- Release the parking brake.

- The speed difference between front and rear wheels may light either the ABS warning light, but this indicates no malfunctions. When the engine control diagnosis is finished, perform the ABS memory clearance procedure of self-diagnosis system.

3. OBD-II GENERAL SCAN TOOL

1) After clearing memory, check for any remaining unresolved trouble data: <Ref. to EN(H4SO)(diag)-44, Clear Memory Mode.>

2) Warm up the engine.

3) Connect the test mode connector (A) at the lower side of instrument panel (on the driver's side).

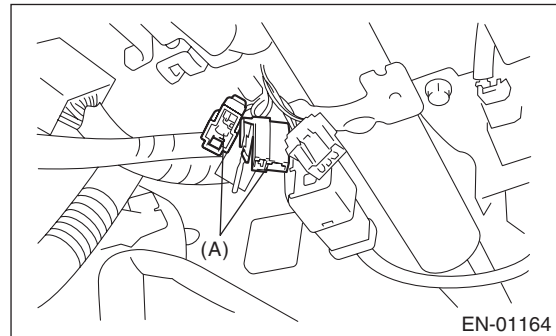

4) Connect the OBD-II general scan tool to its data link connector.

CAUTION:

Do not connect the scan tools except for Subaru Select Monitor and OBD-II general scan tool.

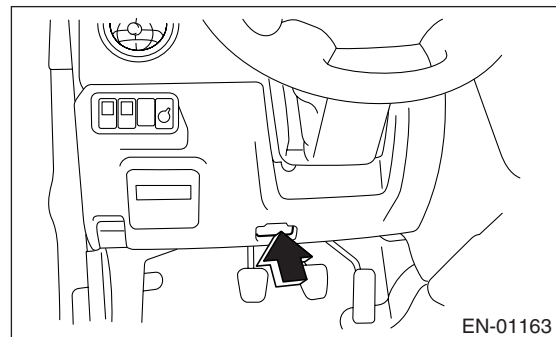

5) Start the engine.

NOTE:

- Ensure the selector lever is placed in "P" position before starting. (AT models)

- Depress the clutch pedal when starting engine. (MT models)

6) Using the selector lever or shift lever, turn the "P" position switch and "N" position switch to ON.

7) Depress the brake pedal to turn brake switch ON. (AT models)

8) Keep the engine speed in 2,500 — 3,000 rpm range for 40 seconds.

9) Place the selector lever or shift lever in “D” position (AT models) or “1st” gear (MT models) and drive the vehicle at 5 to 10 km/h (3 to 6 MPH).

NOTE:

- On AWD vehicles, release the parking brake.
- The speed difference between front and rear wheels may light ABS warning light, but this indicates no malfunctions. When the engine control diagnosis is finished, perform the ABS memory clearance procedure of self-diagnosis system.

10) Using the OBD-II general scan tool, check for DTC and record the result(s).

NOTE:

- For detailed operation procedures, refer to the OBD-II General Scan Tool Instruction Manual.
- For details concerning DTC, refer to the List of Diagnostic Trouble Code (DTC).

<Ref. to EN(H4SO)(diag)-71, List of Diagnostic Trouble Code (DTC).>

Brought to you by Eris Studios
NOT FOR RESALE

13. Drive Cycle

A: OPERATION

There are three drive patterns for the trouble diagnosis. Driving in the specified pattern allows to diagnose malfunctioning items listed below. After the malfunctioning items listed below are repaired, always check whether they correctly resume their functions by driving in the required drive pattern.

1. PREPARATION FOR DRIVE CYCLE

- 1) Make sure that the fuel remains approx. half amount [20 — 40 ℓ (5.3 — 10.6 US gal, 4.4 — 8.8 Imp gal)], and battery voltage is 12 V or more.
- 2) After performing the diagnostics and cleaning memory, check for any remaining unresolved trouble data. <Ref. to EN(H4SO)(diag)-44, Clear Memory Mode.>
- 3) Separate the test mode connector.

NOTE:

- Except for the water temperature specified items at starting, the diagnosis is carried out after engine warm up.
- Carry out the diagnosis which is marked * on DTC twice, then, after finishing first diagnosis, stop the engine and do second time at the same condition.

2. AFTER RUNNING 20 MINUTES AT 80 KM/H (50 MPH), IDLE ENGINE FOR 1 MINUTE.

DTC	Item	Condition
P0067	Air Assisted Injector Control Circuit High	Coolant temperature at start is less than 60°C (140°F).
*P0125	Insufficient Coolant Temperature for Closed Loop Fuel Control	Coolant temperature at start is less than 20°C (68°F).
*P0128	Coolant Thermostat (Coolant Temperature Below Thermostat Regulating Temperature)	—
*P0133	O ₂ Sensor Circuit Slow Response (Bank 1 Sensor 1)	—
*P0181	Fuel Temperature Sensor “A” Circuit Range/Performance	—
*P0420	Catalyst System Efficiency Below Threshold (Bank 1)	—
*P0442	Evaporative Emission Control System Leak Detected (small leak)	—
*P0451	Evaporative Emission Control System Pressure Sensor Range/Performance	—
*P0456	Evaporative Emission Control System Leak Detected (very small leak)	—
*P0457	Evaporative Emission Control System Leak Detected (fuel cap loose/off)	—
*P0459	Evaporative Emission Control System Purge Control Valve Circuit High	—
*P0461	Fuel Level Sensor Circuit Range/Performance	—
*P0692	Cooling Fan 1 Control Circuit High	—
P1137	O ₂ Sensor Circuit (Bank1 Sensor1)	—
P1443	Vent Control Solenoid Valve Function Problem	—
*P1448	Fuel Tank Sensor Control Valve Range/Performance Problem	—
P2096	Post Catalyst Fuel Trim System Too Lean Bank 1	—
P2097	Post Catalyst Fuel Trim System Too Rich Bank 1	—

3. DRIVE ACCORDING TO THE FOLLOWING DRIVE PATTERN

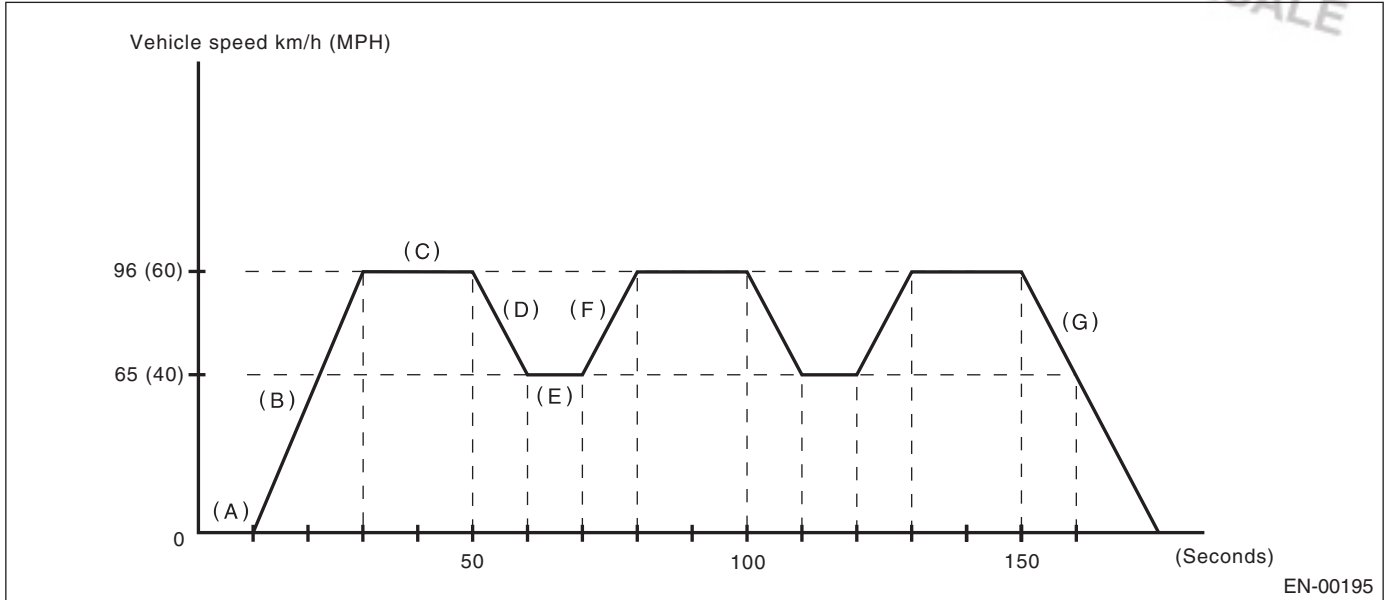

- | | | |
|---|--|---|
| (A) Idle engine for 1 minute. | (D) Decelerate with fully closed throttle to 65 km/h (40 MPH). | (F) Accelerate to 96 km/h (60 MPH) within 10 seconds. |
| (B) Accelerate to 96 km/h (60 MPH) within 20 seconds. | (E) Drive vehicle at 65 km/h (40 MPH) for 10 seconds. | (G) Stop vehicle with throttle fully closed. |
| (C) Drive vehicle at 96 km/h (60 MPH) for 20 seconds. | | |

DTC	Item	Condition
*P0065	Air Assisted Injector Control Range/Performance	—
*P0121	Throttle/Pedal Position Sensor/Switch "A" Circuit Range/Performance	—
*P0139	O ₂ Sensor Circuit Slow Response (Bank 1 Sensor 2)	—
*P0301	Cylinder 1 Misfire Detected	Diagnosis frequency is different from misfire ratio.
*P0302	Cylinder 2 Misfire Detected	Diagnosis frequency is different from misfire ratio.
*P0303	Cylinder 3 Misfire Detected	Diagnosis frequency is different from misfire ratio.
*P0304	Cylinder 4 Misfire Detected	Diagnosis frequency is different from misfire ratio.

4. TEN MINUTES IDLING

NOTE:

Drive the vehicle at 10 km/h (6 MPH) or more before diagnosis.

DTC	Item	Condition
*P0111	Intake Air Temperature Circuit Range/Performance	Coolant temperature at start is less than 30°C (86°F).
*P0171	System Too Lean (Bank 1)	
*P0172	System Too Rich (Bank 1)	
*P0464	Fuel Level Sensor Circuit Intermittent	
*P0483	Cooling Fan Rationality Check	
*P0506	Idle Control System RPM Lower Than Expected	
*P0507	Idle Control System RPM Higher Than Expected	

14. Clear Memory Mode

A: OPERATION

1. SUBARU SELECT MONITOR (NORMAL MODE)

- 1) On «Main Menu» display screen, select the {2. Each System Check} and press the [YES] key.
- 2) On «System Selection Menu» display screen, select the {Engine Control System} and press the [YES] key.
- 3) Press the [YES] key after the information of engine type is displayed.
- 4) On «Engine Diagnosis» display screen, select the {Clear Memory} and press the [YES] key.
- 5) When the 'Done' and 'Turn Ignition Switch OFF' are shown on display screen, turn the ignition switch to OFF, and then turn the Subaru Select Monitor to OFF.

NOTE:

- After the memory has been cleared, the idle air control solenoid valve must be initialized. To do this, turn the ignition switch to ON position. Wait 3 seconds before starting the engine.
- For detailed operation procedure, refer to SUBARU SELECT MONITOR OPERATION MANUAL.

2. SUBARU SELECT MONITOR (OBD MODE)

- 1) On «Main Menu» display screen, select the {2. Each System Check} and press the [YES] key.
- 2) On «System Selection Menu» display screen, select the {Engine Control System} and press the [YES] key.
- 3) Press the [YES] key after the information of engine type is displayed.
- 4) On «Engine Diagnosis» display screen, select the {OBD System} and press the [YES] key.
- 5) On «OBD Menu» display screen, select the {4. Diagnosis Code(s) Cleared} and press the [YES] key.
- 6) When the 'Clear Diagnostic Code?' is shown on the display screen, press the [YES] key.
- 7) Turn the Subaru Select Monitor and ignition switch to OFF.

NOTE:

- After the memory has been cleared, the idle air control solenoid valve must be initialized. To do this, turn the ignition switch to ON position. Wait 3 seconds before starting the engine.
- For detailed operation procedure, refer to SUBARU SELECT MONITOR OPERATION MANUAL.

3. OBD-II GENERAL SCAN TOOL

For clear memory procedures using the OBD-II general scan tool, refer to OBD-II General Scan Tool Instruction Manual.

After the memory has been cleared, the idle air control solenoid valve must be initialized. To do this, turn the ignition switch to ON position. Wait 3 seconds before starting the engine.

15. Compulsory Valve Operation Check Mode

A: OPERATION

1) Prepare the Subaru Select Monitor kit. <Ref. to EN(H4SO)(diag)-8, PREPARATION TOOL, General Description.>

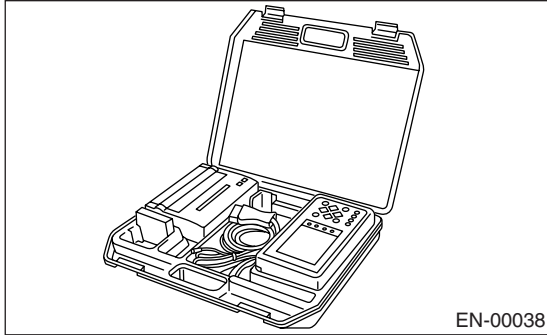

2) Connect the diagnosis cable to Subaru Select Monitor.

3) Insert the cartridge into Subaru Select Monitor. <Ref. to EN(H4SO)(diag)-8, PREPARATION TOOL, General Description.>

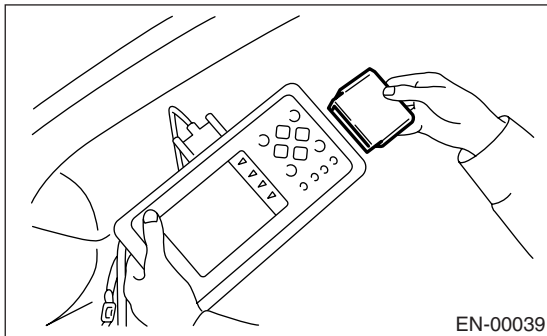

4) Connect the test mode connector (A) at the lower portion of instrument panel (on driver's side).

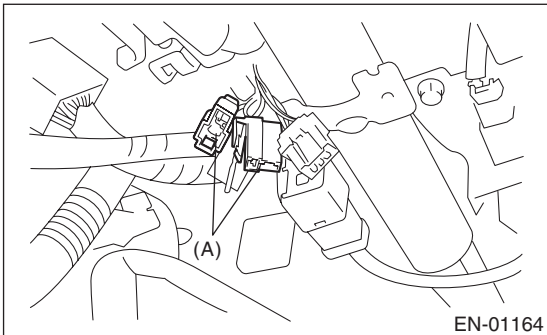

5) Connect the Subaru Select Monitor to data link connector.

(1) Data link connector is located in the lower portion of instrument panel (on driver's side).

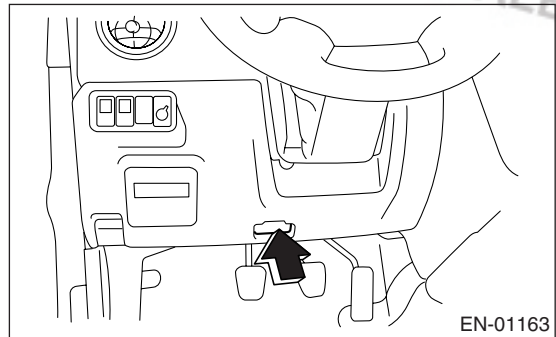

(2) Connect the diagnosis cable to data link connector.

CAUTION:

Do not connect scan tools except for Subaru Select Monitor and OBD-II general scan tool.

6) Turn the ignition switch to ON (engine OFF) and Subaru Select Monitor switch to ON.

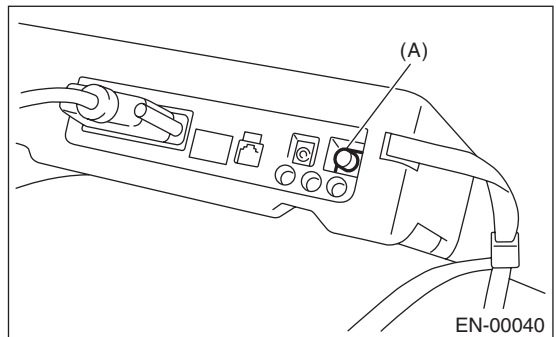

(A) Power switch

7) On «Main Menu» display screen, select the {2. Each System Check} and press the [YES] key.

8) On «System Selection Menu» display screen, select the {Engine Control System} and press the [YES] key.

9) Press the [YES] key after the information of engine type is displayed.

10) On «Engine Diagnosis» display screen, select the {System Operation Check Mode} and press the [YES] key.

11) On «System Operation Check Mode» display screen, select the {Actuator ON/OFF Operation} and press the [YES] key.

12) Select the desired compulsory actuator on the «Actuator ON/OFF Operation» display screen and press the [YES] key.

13) Pressing the [NO] key completes the compulsory operation check mode. The display will then return to the «Actuator ON/OFF Operation» screen.

Compulsory Valve Operation Check Mode

ENGINE (DIAGNOSTICS)

- A list of support data is shown in the following table.

Contents	Display
Compulsory fuel pump relay operation check	Fuel Pump Relay
Compulsory radiator fan relay operation check	Radiator Fan Relay
Compulsory air conditioning relay operation check	A/C Compressor Relay
Compulsory purge control solenoid valve operation check	CPC Solenoid Valve
Compulsory air assist injector solenoid valve operation check	AAI Solenoid Valve
Compulsory pressure control solenoid valve operation check	PCV Solenoid Valve
Compulsory air assist vent control solenoid valve operation check	Vent Control Solenoid Valve
Compulsory fuel tank sensor control solenoid valve operation check	Fuel Tank Sensor Control Valve

NOTE:

- The following parts will be displayed but not functional because they are not installed on vehicle.

Display
Turbocharger Wastegate Solenoid
ASV Solenoid Valve
FICD Solenoid
Pressure Switching Sol. 1
Pressure Switching Sol. 2
Turbocharger Wastegate Solenoid

- For detailed operation procedure, refer to SUBARU SELECT MONITOR OPERATION MANUAL.

16. Malfunction Indicator Light

A: PROCEDURE

1. Activation of malfunction indicator light. <Ref. to EN(H4SO)(diag)-48, ACTIVATION OF MALFUNCTION INDICATOR LIGHT, Malfunction Indicator Light.>
↓
2. Malfunction indicator light does not come on. <Ref. to EN(H4SO)(diag)-49, MALFUNCTION INDICATOR LIGHT DOES NOT COME ON., Malfunction Indicator Light.>
↓
3. Malfunction indicator light does not go off. <Ref. to EN(H4SO)(diag)-51, MALFUNCTION INDICATOR LIGHT DOES NOT GO OFF., Malfunction Indicator Light.>
↓
4. Malfunction indicator light does not blink at a cycle of 3 Hz. <Ref. to EN(H4SO)(diag)-52, MALFUNCTION INDICATOR LIGHT DOES NOT BLINK AT A CYCLE OF 3 HZ., Malfunction Indicator Light.>
↓
5. Malfunction indicator light remains blinking at a cycle of 3 Hz. <Ref. to EN(H4SO)(diag)-54, MALFUNCTION INDICATOR LIGHT REMAINS BLINKING AT A CYCLE OF 3 HZ., Malfunction Indicator Light.>

Malfunction Indicator Light

ENGINE (DIAGNOSTICS)

B: ACTIVATION OF MALFUNCTION INDICATOR LIGHT

1) When the ignition switch is turned to ON (engine off), the malfunction indicator light (A) in the combination meter illuminates.

NOTE:

If the malfunction indicator light does not illuminate, perform diagnostics of the malfunction indicator light circuit or the combination meter circuit. <Ref. to EN(H4SO)(diag)-49, MALFUNCTION INDICATOR LIGHT DOES NOT COME ON., Malfunction Indicator Light.>

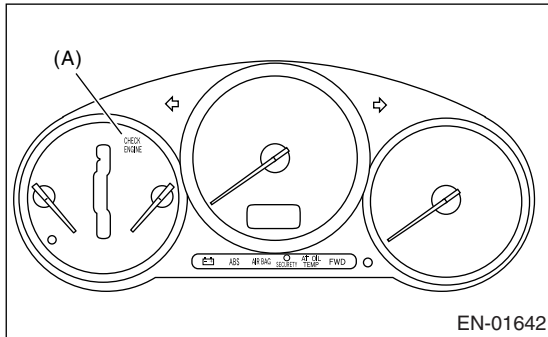

2) After starting the engine, the malfunction indicator light goes out. If it does not, either the engine or the emission control system is malfunctioning.

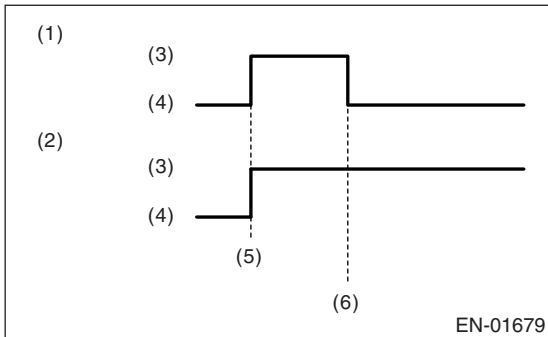

- (1) No trouble
- (2) Trouble occurs
- (3) ON
- (4) OFF
- (5) Ignition switch ON
- (6) Engine start

3) If the diagnosis system senses a misfire which could damage the catalyzer, the malfunction indicator light will blink at a cycle of 1 Hz.

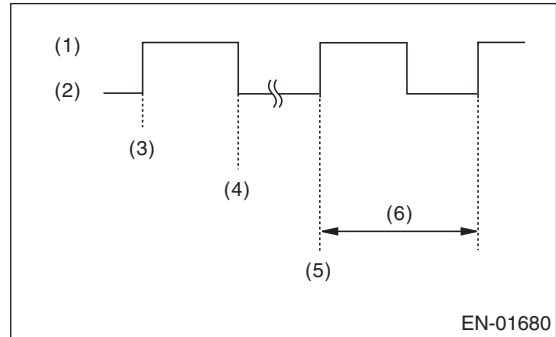

- (1) ON
- (2) OFF
- (3) Ignition switch ON
- (4) Engine start
- (5) Misfire start
- (6) 1 second

4) When the ignition switch is turned to ON (engine off) or to "START" with test mode connector connected, the malfunction indicator light blinks at a cycle of 3 Hz.

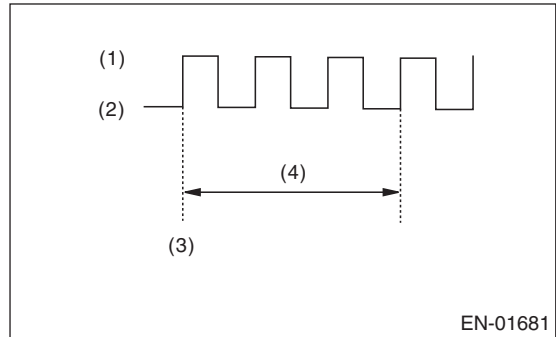

- (1) ON
- (2) OFF
- (3) Ignition switch ON
- (4) 1 second

Malfunction Indicator Light

ENGINE (DIAGNOSTICS)

C: MALFUNCTION INDICATOR LIGHT DOES NOT COME ON.

DIAGNOSIS:

The malfunction indicator light circuit is open or shorted.

TROUBLE SYMPTOM:

When the ignition switch is turned ON (engine OFF), malfunction indicator light does not come on.

WIRING DIAGRAM:

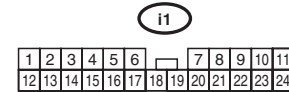
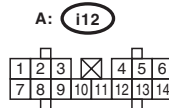
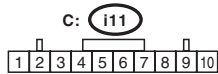
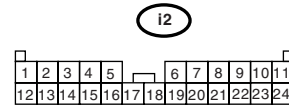
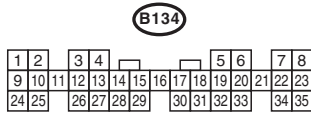
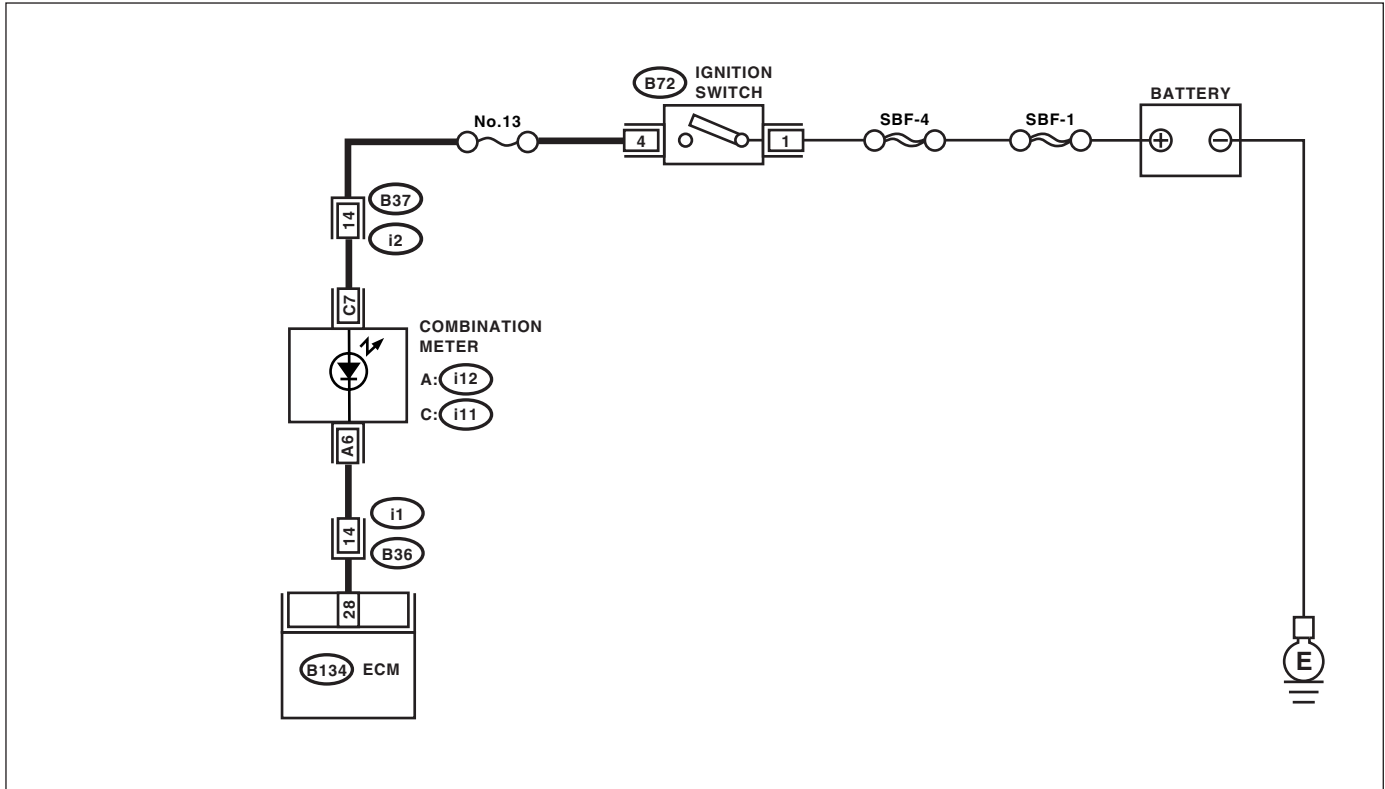

EN-01643

Malfunction Indicator Light

ENGINE (DIAGNOSTICS)

Step	Check	Yes	No
1 CHECK OUTPUT SIGNAL FROM ECM. 1) Turn the ignition switch to ON. 2) Measure the voltage between ECM connector and chassis ground. Connector & terminal (B134) No. 28 (+) — Chassis ground (-):	Is the voltage less than 1 V?	Go to step 4.	Go to step 2.
2 CHECK POOR CONTACT. Check poor contact by shaking or pulling ECM connector and harness.	Does the malfunction indicator light illuminate?	Repair poor contact in ECM connector.	Go to step 3.
3 CHECK ECM CONNECTOR. Check the ECM connector connection.	Is the ECM connector correctly connected?	Replace the ECM. <Ref. to FU(H4SO)-44, Engine Control Module (ECM).>	Repair connection of ECM connector.
4 CHECK HARNESS BETWEEN COMBINATION METER AND ECM CONNECTOR. 1) Turn the ignition switch to OFF. 2) Remove the combination meter. <Ref. to IDI-10, Combination Meter Assembly.> 3) Disconnect the connector from ECM and combination meter. 4) Measure the resistance of harness between ECM and combination meter connector. Connector & terminal (B134) No. 28 — (i12) No. 6:	Is the resistance less than 1 Ω ?	Go to step 5.	Repair harness and connector. NOTE: In this case, repair the following: <ul style="list-style-type: none"> • Open circuit in harness between ECM and combination meter connector • Poor contact in coupling connector
5 CHECK POOR CONTACT. Check poor contact in combination meter connector.	Is there poor contact in combination meter connector?	Repair poor contact in combination meter connector.	Go to step 6.
6 CHECK HARNESS BETWEEN COMBINATION METER AND IGNITION SWITCH CONNECTOR. 1) Turn the ignition switch to ON. 2) Measure the voltage between combination meter connector and chassis ground. Connector & terminal (i11) No. 7 (+) — Chassis ground (-):	Is the voltage more than 10 V?	Replace the combination meter circuit board. <Ref. to IDI-10, Combination Meter Assembly.>	Check the following and repair if necessary. NOTE: <ul style="list-style-type: none"> • Blown out fuse (No. 13). • Open or short circuit in harness between fuse (No. 13) and battery terminal • Poor contact in ignition switch connector

Malfunction Indicator Light

ENGINE (DIAGNOSTICS)

D: MALFUNCTION INDICATOR LIGHT DOES NOT GO OFF.

DIAGNOSIS:

The malfunction indicator light circuit is shorted.

TROUBLE SYMPTOM:

Although malfunction indicator light comes on when the engine runs, DTC is not shown on Subaru select monitor or OBD-II general scan tool display.

WIRING DIAGRAM:

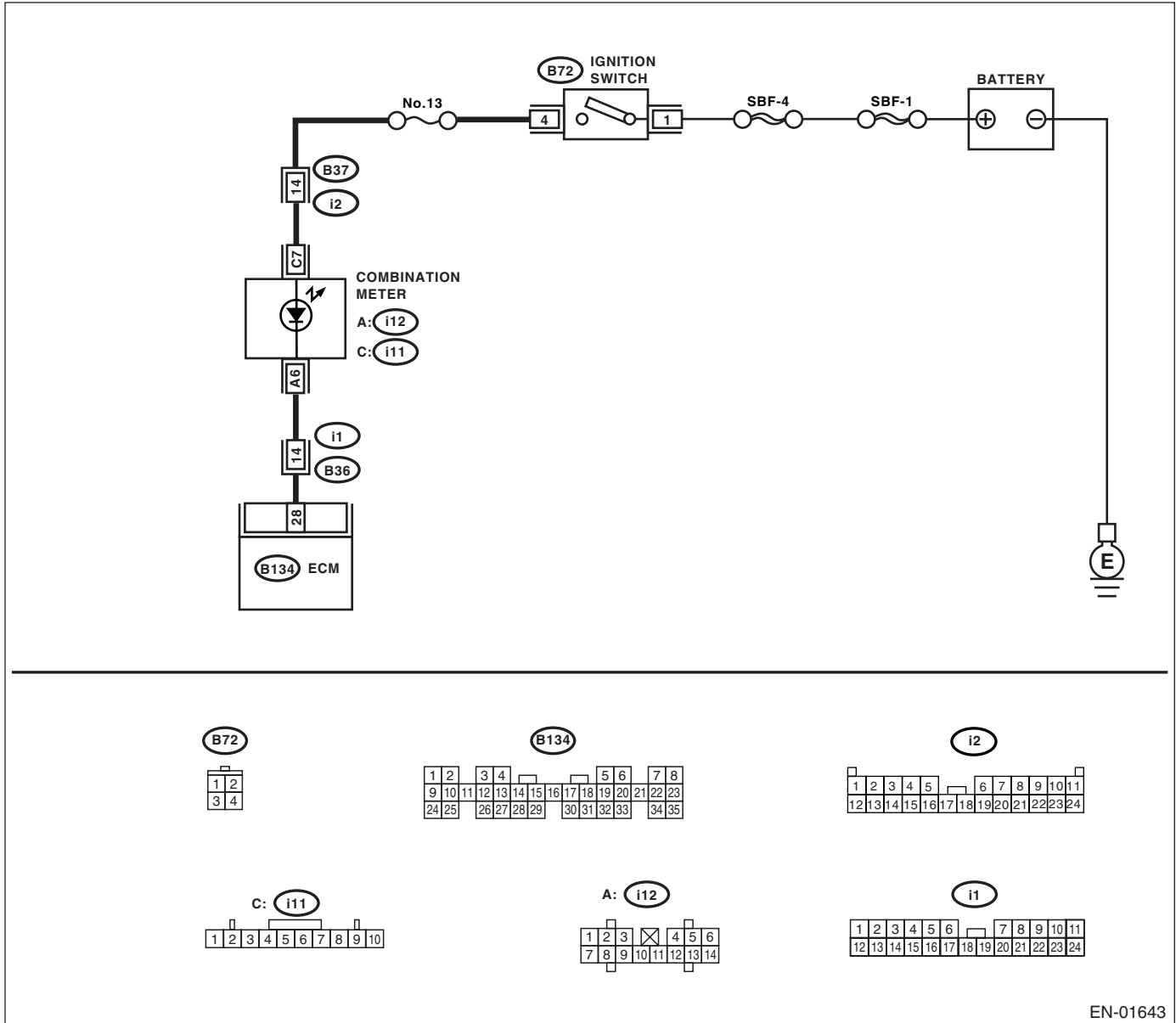

Step	Check	Yes	No	
1	<p>CHECK HARNESS BETWEEN COMBINATION METER AND ECM CONNECTOR.</p> <p>1) Turn the ignition switch to OFF. 2) Disconnect the connector from ECM. 3) Turn the ignition switch to ON.</p>	<p>Dose the malfunction indicator light illuminate?</p>	<p>Repair short circuit in harness between combination meter and ECM connector.</p>	<p>Replace the ECM. <Ref. to FU(H4SO)-44, Engine Control Module (ECM).></p>

Malfunction Indicator Light

ENGINE (DIAGNOSTICS)

E: MALFUNCTION INDICATOR LIGHT DOES NOT BLINK AT A CYCLE OF 3 Hz.

DIAGNOSIS:

- The malfunction indicator light circuit is open or shorted.
- Test mode connector circuit is in open.

TROUBLE SYMPTOM:

When in inspection mode, malfunction indicator light does not blink at a cycle of 3 Hz.

WIRING DIAGRAM:

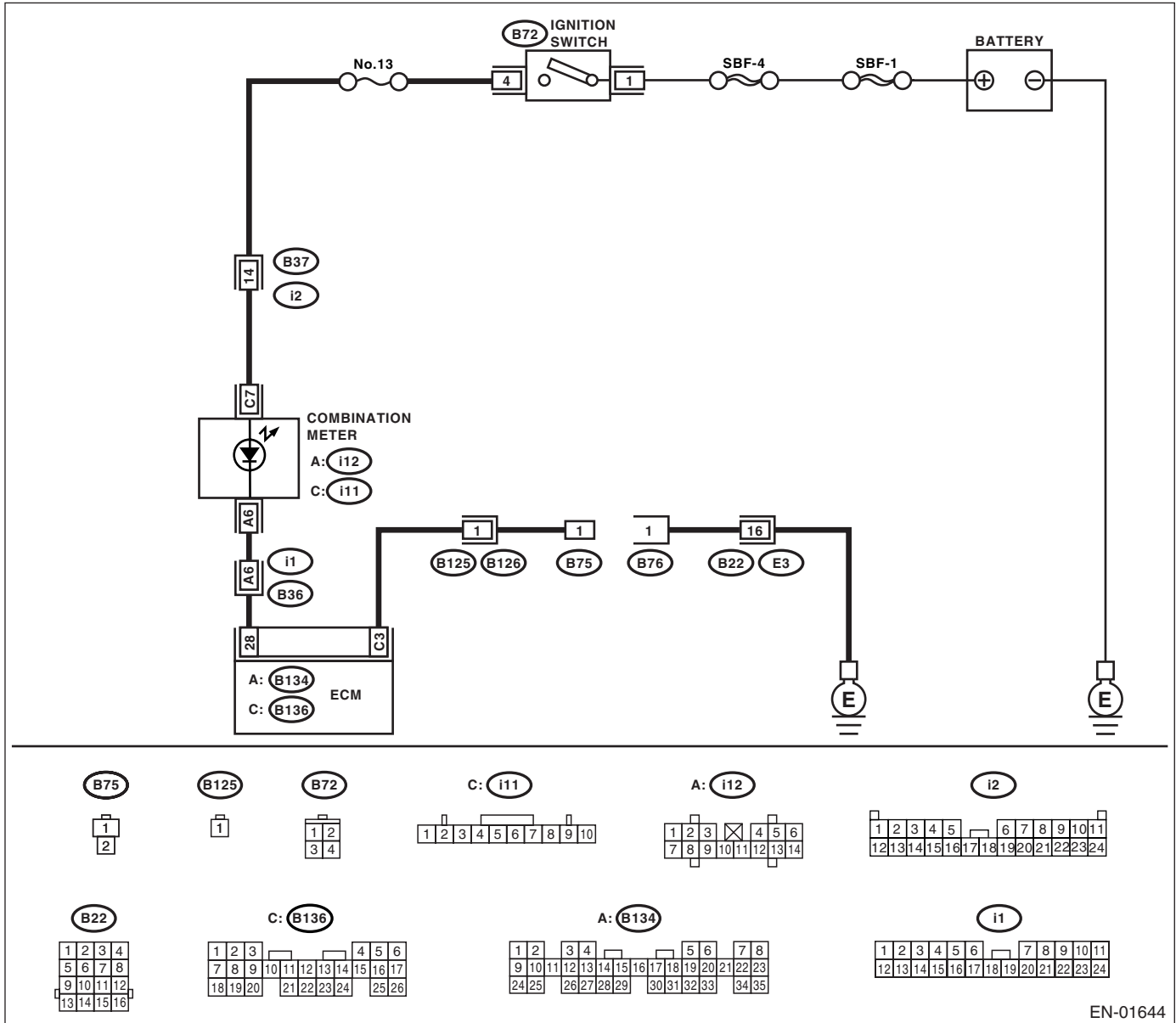

EN-01644

Malfunction Indicator Light

ENGINE (DIAGNOSTICS)

Step	Check	Yes	No
1 CHECK STATUS OF MALFUNCTION INDICATOR LIGHT. 1) Turn the ignition switch to OFF. 2) Disconnect the test mode connector. 3) Turn the ignition switch to ON. (engine OFF)	Does the malfunction indicator light illuminate?	Go to step 2.	Repair the malfunction indicator light circuit. <Ref. to EN(H4SO)(diag)-49, MALFUNCTION INDICATOR LIGHT DOES NOT COME ON., Malfunction Indicator Light.>
2 CHECK HARNESS BETWEEN COMBINATION METER AND ECM CONNECTOR. 1) Turn the ignition switch to OFF. 2) Disconnect the connector from ECM. 3) Turn the ignition switch to ON.	Does the malfunction indicator light illuminate?	Repair ground short circuit in harness between combination meter and ECM connector.	Go to step 3.
3 CHECK HARNESS BETWEEN TEST MODE CONNECTOR AND CHASSIS GROUND. 1) Turn the ignition switch to OFF. 2) Disconnect the connector from ECM. 3) Measure the resistance of harness between test mode connector and chassis ground. <i>Connector & terminal (B76) No. 1 — Chassis ground:</i>	Is the resistance less than 1 Ω ?	Go to step 4.	Repair harness and connector. NOTE: In this case, repair the following: • Open circuit in harness between test mode connector and chassis ground
4 CHECK POOR CONTACT. Check poor contact in ECM connector.	Is there poor contact in ECM connector?	Repair poor contact in ECM connector.	Go to step 5.
5 CHECK HARNESS BETWEEN ECM AND TEST MODE CONNECTOR. 1) Connect the test mode connector. 2) Measure the resistance of harness between ECM and chassis ground. <i>Connector & terminal (B136) No. 3 — Chassis ground:</i>	Is the resistance less than 1 Ω ?	Go to step 6.	Repair open circuit in harness between ECM and test mode connector.
6 CHECK POOR CONTACT. Check poor contact in ECM connector.	Is there poor contact in ECM connector?	Repair poor contact in ECM connector.	Replace the ECM. <Ref. to FU(H4SO)-44, Engine Control Module (ECM).>

Malfunction Indicator Light

ENGINE (DIAGNOSTICS)

F: MALFUNCTION INDICATOR LIGHT REMAINS BLINKING AT A CYCLE OF 3 Hz.

DIAGNOSIS:

Test mode connector circuit is shorted.

TROUBLE SYMPTOM:

Malfunction indicator light blinks at a cycle of 3 Hz when the ignition switch is turned to ON.

WIRING DIAGRAM:

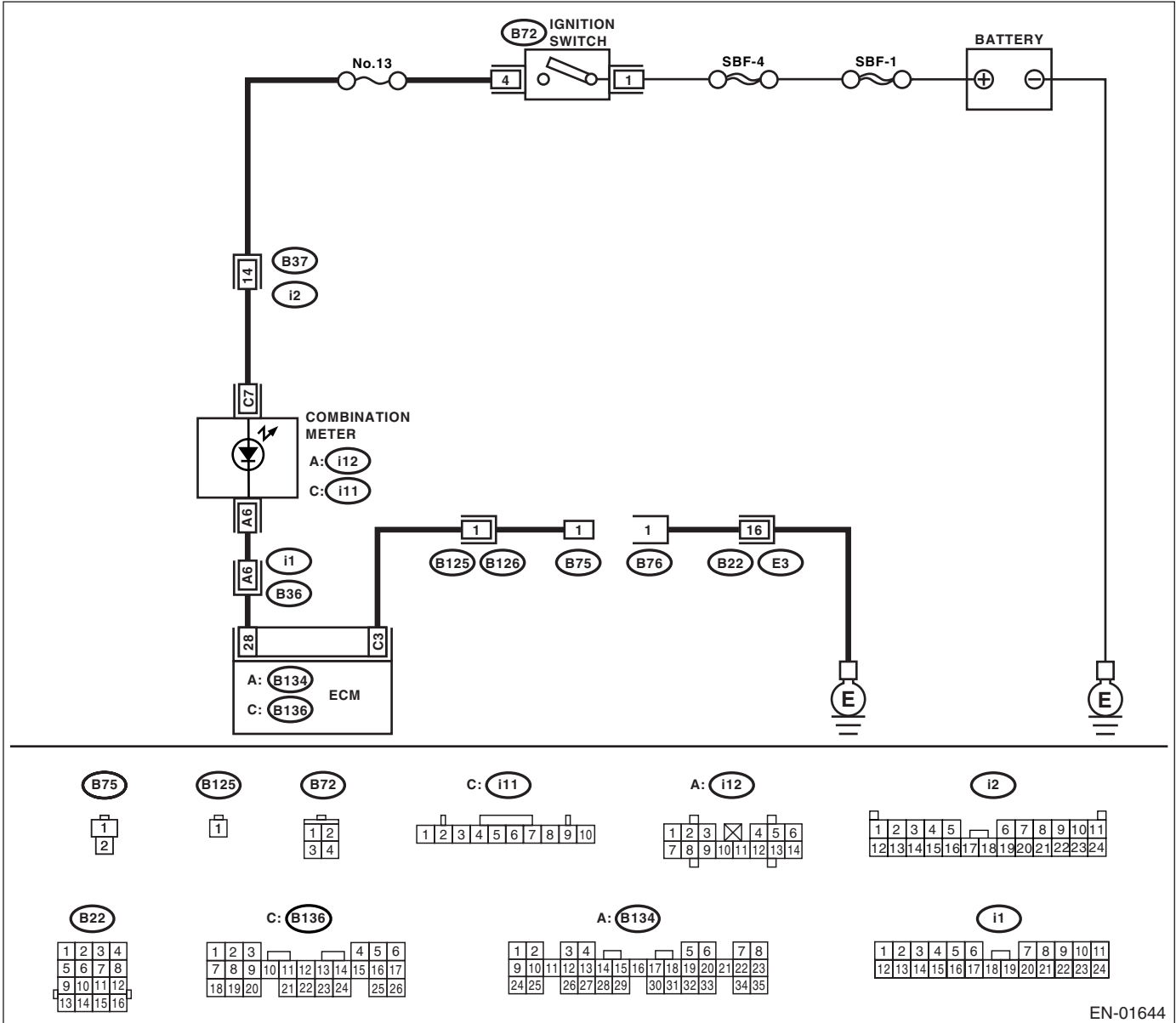

EN-01644

Malfunction Indicator Light

ENGINE (DIAGNOSTICS)

Step	Check	Yes	No
1 CHECK TEST MODE CONNECTOR. 1) Disconnect the test mode connector. 2) Turn the ignition switch to ON.	Does the malfunction indicator light blink?	Go to step 2.	System is in good order. NOTE: Malfunction indicator light blinks at a cycle of 3 Hz when test mode connector is connected.
2 CHECK HARNESS BETWEEN ECM CONNECTOR AND ENGINE GROUNDING TERMINAL. 1) Turn the ignition switch to OFF. 2) Disconnect the connector from ECM. 3) Measure the resistance of harness between ECM connector and chassis ground. Connector & terminal (B136) No. 3 — Chassis ground:	Is the resistance less than 5 Ω ?	Repair short circuit in harness between ECM and test mode connector.	Replace the ECM. <Ref. to FU(H4SO)-44, Engine Control Module (ECM).>

Diagnostics for Engine Starting Failure

ENGINE (DIAGNOSTICS)

17. Diagnostics for Engine Starting Failure

A: PROCEDURE

1. Inspection of starter motor circuit. <Ref. to EN(H4SO)(diag)-57, STARTER MOTOR CIRCUIT, Diagnostics for Engine Starting Failure.>
↓
2. Inspection of ECM power supply and ground line. <Ref. to EN(H4SO)(diag)-60, CONTROL MODULE POWER SUPPLY AND GROUND LINE, Diagnostics for Engine Starting Failure.>
↓
3. Inspection of ignition control system. <Ref. to EN(H4SO)(diag)-63, IGNITION CONTROL SYSTEM, Diagnostics for Engine Starting Failure.>
↓
4. Inspection of fuel pump circuit. <Ref. to EN(H4SO)(diag)-66, FUEL PUMP CIRCUIT, Diagnostics for Engine Starting Failure.>
↓
5. Inspection of fuel injector circuit. <Ref. to EN(H4SO)(diag)-69, FUEL INJECTOR CIRCUIT, Diagnostics for Engine Starting Failure.>

B: STARTER MOTOR CIRCUIT

CAUTION:

After repair or replacement of faulty parts, conduct Clear Memory Mode <Ref. to EN(H4SO)(diag)-44, OPERATION, Clear Memory Mode.> and Inspection Mode <Ref. to EN(H4SO)(diag)-37, OPERATION, Inspection Mode.>.

WIRING DIAGRAM:

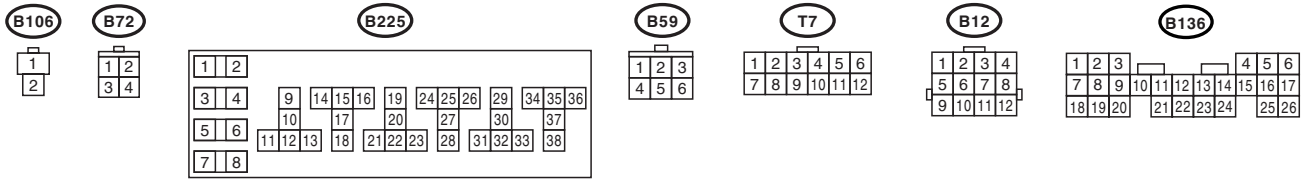
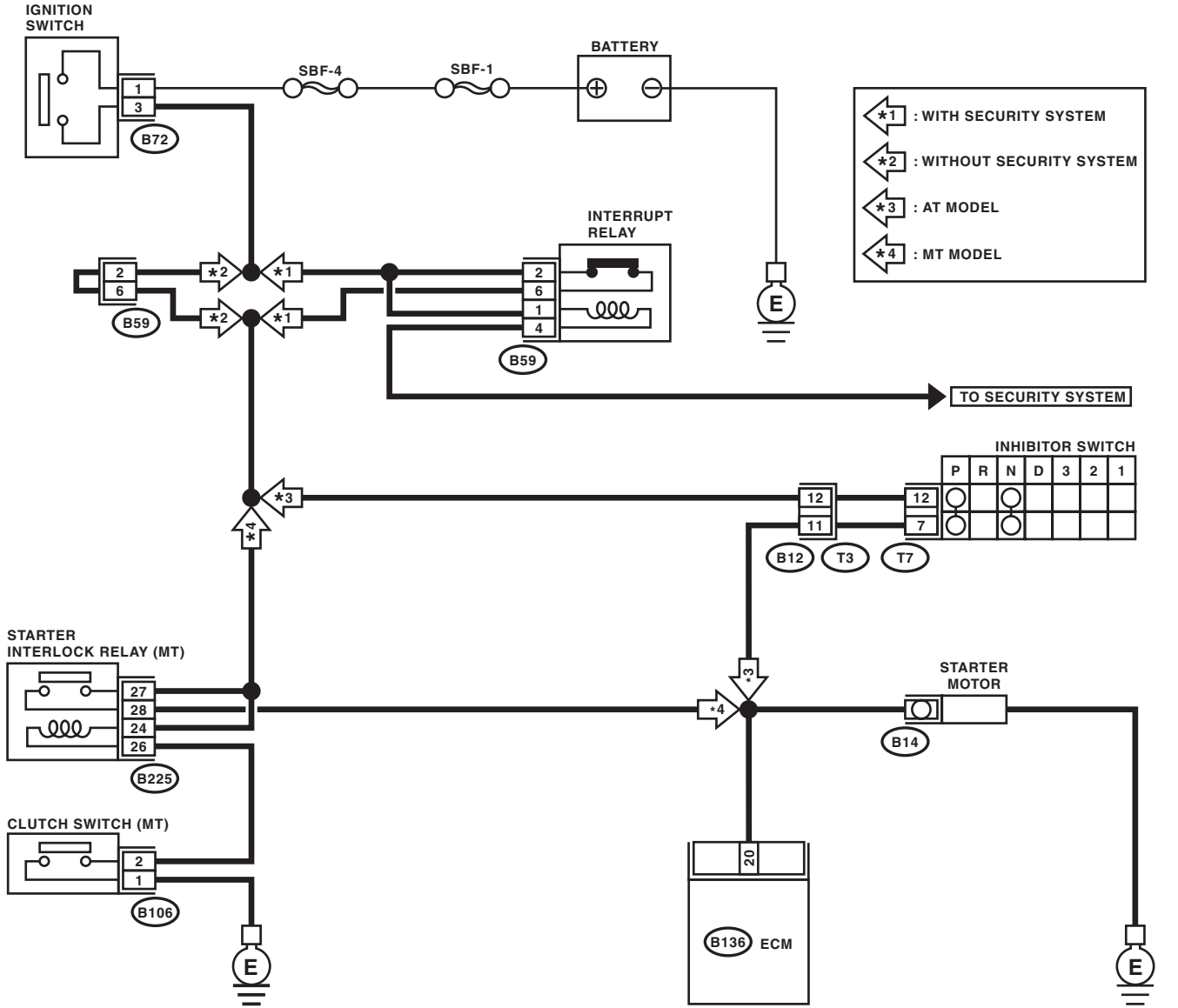

Diagnostics for Engine Starting Failure

ENGINE (DIAGNOSTICS)

Step	Check	Yes	No
1 CHECK BATTERY. Check the battery voltage.	Is the voltage more than 12 V?	Go to step 2.	Charge or replace the battery.
2 CHECK INPUT SIGNAL FOR STARTER MOTOR. 1) Turn the ignition switch to OFF. 2) Disconnect the connector from starter motor. 3) Turn the ignition switch to ST. 4) Measure the power supply voltage between starter motor connector terminal and engine ground. Connector & terminal (B14) No. 1 (+) — Engine ground (-): NOTE: • On AT models, place the select lever in the "P" or "N" range. • On MT models, depress the clutch pedal.	Is the voltage more than 10 V?	Go to step 3.	Go to step 4.
3 CHECK GROUND CIRCUIT OF STARTER MOTOR. 1) Turn the ignition switch to OFF. 2) Disconnect the terminal from starter motor. 3) Measure the resistance of ground cable between ground cable terminal and engine ground.	Is the resistance less than 5 Ω ?	Check the starter motor. <Ref. to SC(H4SO)-7, Starter.>	Repair open circuit of ground cable.
4 CHECK HARNESS BETWEEN BATTERY AND IGNITION SWITCH CONNECTOR. 1) Disconnect the connector from ignition switch. 2) Measure the power supply voltage between ignition switch connector and chassis ground. Connector & terminal (B72) No. 1 (+) — Chassis ground (-):	Is the voltage more than 10 V?	Go to step 5.	Repair open circuit in harness between ignition switch and battery, and check fuse SBF No. 4 and SBF No. 1.
5 CHECK IGNITION SWITCH. 1) Disconnect the connector from ignition switch. 2) Measure the resistance between ignition switch terminals while turning ignition switch to the "ST" position. Terminals No. 1 — No. 3:	Is the resistance less than 5 Ω ?	Go to step 6.	Replace the ignition switch.
6 CHECK TRANSMISSION TYPE.	Is the target AT model?	Go to step 7.	Go to step 9.
7 CHECK INPUT VOLTAGE OF INHIBITOR SWITCH. 1) Turn the ignition switch to OFF. 2) Disconnect the connector from inhibitor switch. 3) Connect the connector to ignition switch. 4) Measure the input voltage between inhibitor switch connector terminal and engine ground while turning ignition switch to ST. Connector & terminal (B12) No. 12 (+) — Engine ground (-):	Is the voltage more than 10 V?	Go to step 8.	Repair open or ground short circuit in harness between inhibitor switch and ignition switch. NOTE: Check security system (if equipped). <Ref. to SL-20, Security System.>

Diagnostics for Engine Starting Failure

ENGINE (DIAGNOSTICS)

Step	Check	Yes	No
8 CHECK INHIBITOR SWITCH. 1) Place the select lever in the "P" or "N" range. 2) Measure the resistance between inhibitor switch terminals. <i>Connector & terminal</i> <i>(T3) No. 11 — No. 12:</i>	Is the resistance less than 1 Ω ?	Repair open or ground short circuit in harness between inhibitor switch and starter motor.	Replace the inhibitor switch. <Ref. to 4AT-46, Inhibitor Switch.>
9 CHECK INPUT VOLTAGE OF STARTER INTERLOCK RELAY. 1) Turn ignition switch to OFF. 2) Disconnect the connector from starter interlock relay. 3) Connect the connector to ignition switch. 4) Measure the input voltage between starter interlock relay connector and chassis ground while turning ignition switch to ST. <i>Connector & terminal</i> <i>(B225) No. 24 (+) — Chassis ground (-):</i> <i>(B225) No. 27 (+) — Chassis ground (-):</i>	Is the voltage more than 10 V?	Go to step 10.	Repair open or short circuit to ground in harness between starter interlock relay and ignition switch. NOTE: Check security system (if equipped). <Ref. to SL-20, Security System.>
10 CHECK STARTER INTERLOCK RELAY. 1) Connect the battery to starter interlock relay terminals No. 26 and No. 24. 2) Measure the resistance between starter interlock relay terminals. <i>Terminals</i> <i>No. 27 — No. 28:</i>	Is the resistance less than 1 Ω ?	Go to step 11.	Replace the starter interlock relay.
11 CHECK GROUND CIRCUIT OF CLUTCH SWITCH. 1) Disconnect the connector from clutch switch. 2) Measure the resistance between clutch switch connector and chassis ground. <i>Connector & terminal</i> <i>(B106) No. 1 — Chassis ground:</i>	Is the resistance less than 1 Ω ?	Go to step 12.	Repair open circuit of ground cable.
12 CHECK CLUTCH SWITCH. Measure the resistance between clutch switch terminals while depressing the clutch pedal. <i>Terminals</i> <i>No. 1 — No. 2:</i>	Is the resistance less than 1 Ω ?	Go to step 13.	Replace the clutch switch. <Ref. to CL-28, Clutch Switch.>
13 CHECK CLUTCH SWITCH CIRCUIT. 1) Connect the connector to clutch switch. 2) Measure the resistance between starter interlock relay connector and chassis ground while depressing the clutch pedal. <i>Connector & terminal</i> <i>(B225) No. 26 (+) — Chassis ground (-):</i>	Is the resistance less than 1 Ω ?	Repair short circuit to ground in harness between starter interlock relay and starter motor.	Repair open circuit in harness between starter interlock relay and clutch switch.

Diagnostics for Engine Starting Failure

ENGINE (DIAGNOSTICS)

C: CONTROL MODULE POWER SUPPLY AND GROUND LINE

CAUTION:

After repair or replacement of faulty parts, conduct Clear Memory Mode <Ref. to EN(H4SO)(diag)-44, OPERATION, Clear Memory Mode.> and Inspection Mode <Ref. to EN(H4SO)(diag)-37, OPERATION, Inspection Mode.>.

WIRING DIAGRAM:

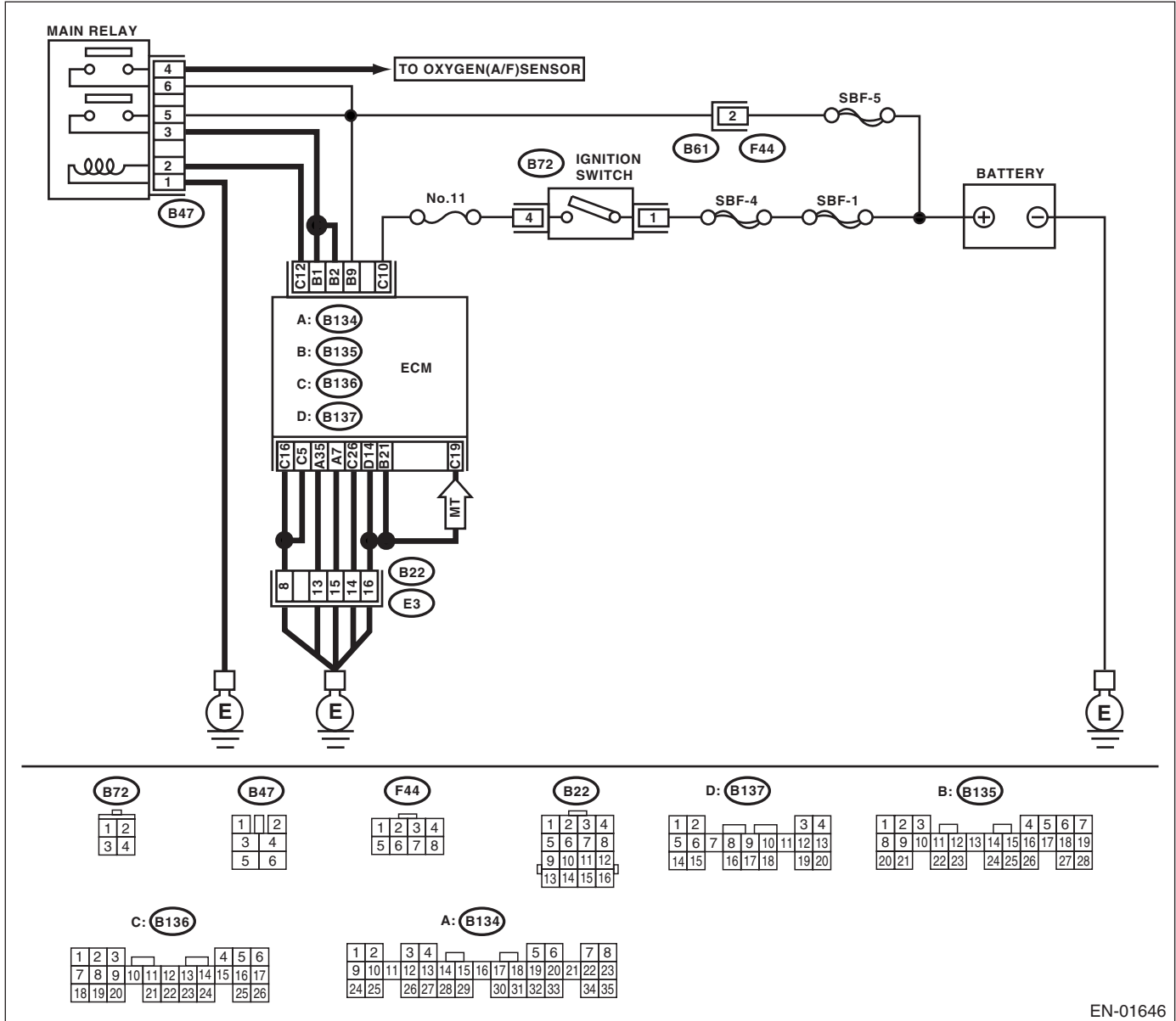

EN-01646

Diagnostics for Engine Starting Failure

ENGINE (DIAGNOSTICS)

Step	Check	Yes	No
1 CHECK MAIN RELAY. 1) Turn the ignition switch to OFF. 2) Remove the main relay. 3) Connect the battery to main relay terminals No. 1 and No. 2. 4) Measure the resistance between main relay terminals. <i>Terminals</i> <i>No. 3 — No. 5:</i> <i>No. 4 — No. 6:</i>	Is the resistance less than 10 Ω ?	Go to step 2.	Replace the main relay.
2 CHECK GROUND CIRCUIT OF ECM. 1) Disconnect the connector from ECM. 2) Measure the resistance of harness between ECM and chassis ground. <i>Connector & terminal</i> <i>(B134) No. 7 — Chassis ground:</i> <i>(B134) No. 35 — Chassis ground:</i> <i>(B135) No. 21 — Chassis ground:</i> <i>(B136) No. 5 — Chassis ground:</i> <i>(B136) No. 16 — Chassis ground:</i> <i>(B136) No. 26 — Chassis ground:</i> <i>(B137) No. 14 — Chassis ground:</i> <i>(B136) No. 19 — Chassis ground: (MT model)</i>	Is the resistance less than 5 Ω ?	Go to step 3.	Repair open circuit in harness between ECM connector and engine grounding terminal.
3 CHECK INPUT VOLTAGE OF ECM. Measure the voltage between ECM connector and chassis ground. <i>Connector & terminal</i> <i>(B135) No. 9 (+) — Chassis ground (-):</i>	Is the voltage more than 10 V?	Go to step 4.	Repair open or ground short circuit of power supply circuit.
4 CHECK INPUT VOLTAGE OF ECM. 1) Turn the ignition switch to ON. 2) Measure the voltage between ECM connector and chassis ground. <i>Connector & terminal</i> <i>(B136) No. 10 (+) — Chassis ground (-):</i>	Is the voltage more than 10 V?	Go to step 5.	Repair open or ground short circuit of power supply circuit.
5 CHECK HARNESS BETWEEN ECM AND MAIN RELAY CONNECTOR. 1) Turn the ignition switch to OFF. 2) Measure the resistance between ECM and chassis ground. <i>Connector & terminal</i> <i>(B136) No. 12 — Chassis ground:</i>	Is the resistance more than 1 M Ω ?	Go to step 6.	Repair ground short circuit in harness between ECM connector and main relay connector, then replace the ECM.
6 CHECK OUTPUT VOLTAGE FROM ECM. 1) Connect the connector to ECM. 2) Turn the ignition switch to ON. 3) Measure the voltage between ECM connector and chassis ground. <i>Connector & terminal</i> <i>(B136) No. 12 (+) — Chassis ground (-):</i>	Is the voltage more than 10 V?	Go to step 7.	Replace the ECM.
7 CHECK INPUT VOLTAGE OF MAIN RELAY. Check the voltage between main relay connector and chassis ground. <i>Connector & terminal</i> <i>(B47) No. 2 (+) — Chassis ground (-):</i>	Is the voltage more than 10 V?	Go to step 8.	Repair open circuit in harness between ECM connector and main relay connector.

Diagnostics for Engine Starting Failure

ENGINE (DIAGNOSTICS)

Step	Check	Yes	No
8 CHECK GROUND CIRCUIT OF MAIN RELAY. 1) Turn the ignition switch to OFF. 2) Measure the resistance between main relay connector and chassis ground. <i>Connector & terminal</i> <i>(B47) No. 1 — Chassis ground:</i>	Is the resistance less than 5 Ω ?	Go to step 9 .	Repair open circuit between main relay and chassis ground.
9 CHECK INPUT VOLTAGE OF MAIN RELAY. Measure the voltage between main relay connector and chassis ground. <i>Connector & terminal</i> <i>(B47) No. 5 (+) — Chassis ground (-):</i> <i>(B47) No. 6 (+) — Chassis ground (-):</i>	Is the voltage more than 10 V?	Go to step 10 .	Repair open or ground short circuit in harness of power supply circuit.
10 CHECK INPUT VOLTAGE OF ECM. 1) Connect the main relay connector. 2) Turn the ignition switch to ON. 3) Measure the voltage between ECM connector and chassis ground. <i>Connector & terminal</i> <i>(B135) No. 1 (+) — Chassis ground (-):</i> <i>(B135) No. 2 (+) — Chassis ground (-):</i>	Is the voltage more than 10 V?	Check ignition control system. <Ref. to EN(H4SO)(diag)-63, IGNITION CONTROL SYSTEM, Diagnostics for Engine Starting Failure.>	Repair open or ground short circuit in harness between ECM connector and main relay connector.

D: IGNITION CONTROL SYSTEM

CAUTION:

After repair or replacement of faulty parts, conduct Clear Memory Mode <Ref. to EN(H4SO)(diag)-44, OPERATION, Clear Memory Mode.> and Inspection Mode <Ref. to EN(H4SO)(diag)-37, OPERATION, Inspection Mode.>.

WIRING DIAGRAM:

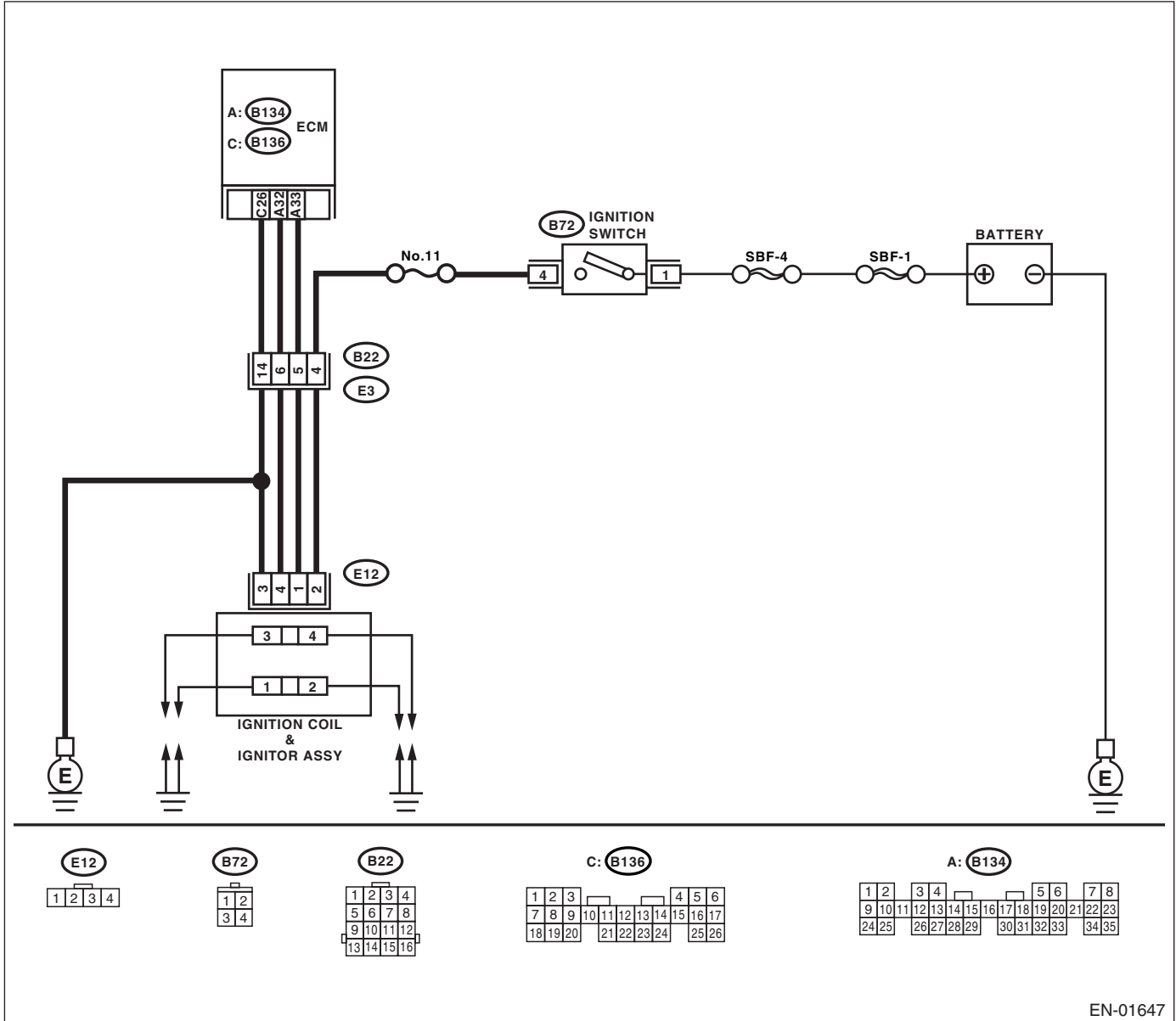

EN-01647

Diagnostics for Engine Starting Failure

ENGINE (DIAGNOSTICS)

Step	Check	Yes	No
<p>1</p> <p>CHECK IGNITION SYSTEM FOR SPARKS. 1) Remove the plug cord cap from each spark plug. 2) Install the new spark plug on plug cord cap.</p> <p>CAUTION: Do not remove the spark plug from engine.</p> <p>3) Contact the spark plug's thread portion on engine. 4) While opening the throttle valve fully, crank the engine to check that spark occurs at each cylinder.</p>	Does spark occur at each cylinder?	Check fuel pump system. <Ref. to EN(H4SO)(diag)-66, FUEL PUMP CIRCUIT, Diagnostics for Engine Starting Failure.>	Go to step 2.
<p>2</p> <p>CHECK POWER SUPPLY CIRCUIT FOR IGNITION COIL & IGNITOR ASSY. 1) Turn the ignition switch to OFF. 2) Disconnect the connector from ignition coil & ignitor ASSY. 3) Turn the ignition switch to ON. 4) Measure the power supply voltage between ignition coil & ignitor ASSY connector and engine ground.</p> <p>Connector & terminal (E12) No. 2 (+) — Engine ground (-):</p>	Is the voltage more than 10 V?	Go to step 3.	Repair harness and connector. NOTE: In this case, repair the following: • Open circuit in harness between ignition coil & ignitor ASSY, and ignition switch connector • Poor contact in coupling connectors
<p>3</p> <p>CHECK HARNESS OF IGNITION COIL & IGNITOR ASSY GROUND CIRCUIT. 1) Turn the ignition switch to OFF. 2) Measure the resistance between ignition coil & ignitor ASSY connector and engine ground.</p> <p>Connector & terminal (E12) No. 3 — Engine ground:</p>	Is the resistance less than 5 Ω ?	Go to step 4.	Repair harness and connector. NOTE: In this case, repair the following: • Open circuit in harness between ignition coil & ignitor ASSY connector and engine grounding terminal
<p>4</p> <p>CHECK IGNITION COIL & IGNITOR ASSY. 1) Remove the spark plug cords. 2) Measure the resistance between spark plug cord contact portions to check secondary coil.</p> <p>Terminals No. 1 — No. 2: No. 3 — No. 4:</p>	Is the resistance 10 — 15 k Ω ?	Go to step 5.	Replace the ignition coil & ignitor ASSY. <Ref. to IG(H4SO)-7, Ignition Coil & Ignitor ASSY.>
<p>5</p> <p>CHECK INPUT SIGNAL FOR IGNITION COIL & IGNITOR ASSY. 1) Connect the connector to ignition coil & ignitor ASSY. 2) Check if voltage varies synchronously with engine speed when cranking, while monitoring voltage between ignition coil & ignitor ASSY connector and engine ground.</p> <p>Connector & terminal (E12) No. 1 (+) — Engine ground (-): (E12) No. 4 (+) — Engine ground (-):</p>	Does the voltage vary more than 10 V?	Go to step 6.	Replace the ignition coil & ignitor ASSY. <Ref. to IG(H4SO)-7, Ignition Coil & Ignitor ASSY.>

Diagnostics for Engine Starting Failure

ENGINE (DIAGNOSTICS)

Step	Check	Yes	No
<p>6</p> <p>CHECK HARNESS BETWEEN ECM AND IGNITION COIL & IGNITOR ASSY CONNECTOR.</p> <p>1) Turn the ignition switch to OFF. 2) Disconnect the connector from ECM. 3) Disconnect the connector from ignition coil & ignitor ASSY. 4) Measure the resistance of harness between ECM and ignition coil & ignitor ASSY connector.</p> <p>Connector & terminal (B134) No. 33 — (E12) No. 1: (B134) No. 32 — (E12) No. 4:</p>	<p>Is the resistance less than 1 Ω?</p>	<p>Go to step 7.</p>	<p>Repair harness and connector.</p> <p>NOTE: In this case, repair the following:</p> <ul style="list-style-type: none"> • Open circuit in harness between ECM and ignition coil & ignitor ASSY connector • Poor contact in coupling connector
<p>7</p> <p>CHECK HARNESS BETWEEN ECM AND IGNITION COIL & IGNITOR ASSY CONNECTOR.</p> <p>Measure the resistance of harness between ECM and engine ground.</p> <p>Connector & terminal: (B134) No. 33 — Engine ground: (B134) No. 32 — Engine ground:</p>	<p>Is the resistance more than 1 MΩ?</p>	<p>Go to step 8.</p>	<p>Repair ground short circuit in harness between ECM and ignition coil & ignitor ASSY connector.</p>
<p>8</p> <p>CHECK POOR CONTACT.</p> <p>Check poor contact in ECM connector.</p>	<p>Is there poor contact in ECM connector?</p>	<p>Repair poor contact in ECM connector.</p>	<p>Check fuel pump circuit. <Ref. to EN(H4SO)(diag)-66, FUEL PUMP CIRCUIT, Diagnostics for Engine Starting Failure.></p>

Diagnostics for Engine Starting Failure

ENGINE (DIAGNOSTICS)

Step	Check	Yes	No
<p>1 CHECK OPERATING SOUND OF FUEL PUMP. Make sure that fuel pump is in operation for two seconds when turning the ignition switch to ON.</p> <p>NOTE: Fuel pump operation can also be executed using Subaru Select Monitor. For the procedure, refer to "Compulsory Valve Operation Check Mode". <Ref. to EN(H4SO)(diag)-45, Compulsory Valve Operation Check Mode.></p>	Does the fuel pump produce operating sound?	Check fuel injector circuit. <Ref. to EN(H4SO)(diag)-69, FUEL INJECTOR CIRCUIT, Diagnostics for Engine Starting Failure.>	Go to step 2.
<p>2 CHECK GROUND CIRCUIT OF FUEL PUMP. 1) Turn the ignition switch to OFF. 2) Remove the fuel pump access hole lid. 3) Disconnect the connector from fuel pump. 4) Measure the resistance of harness connector between fuel pump and chassis ground.</p> <p>Connector & terminal (R58) No. 4 — Chassis ground:</p>	Is the resistance less than 5 Ω ?	Go to step 3.	Repair harness and connector. NOTE: In this case, repair the following: <ul style="list-style-type: none"> • Open circuit in harness between fuel pump connector and chassis grounding terminal • Poor contact in coupling connector
<p>3 CHECK POWER SUPPLY TO FUEL PUMP. 1) Turn the ignition switch to ON. 2) Measure the voltage of power supply circuit between fuel pump connector and chassis ground.</p> <p>Connector & terminal (R58) No. 1 (+) — Chassis ground (-):</p>	Is the voltage more than 10 V?	Replace the fuel pump. <Ref. to FU(H4SO)-55, Fuel Pump.>	Go to step 4.
<p>4 CHECK HARNESS BETWEEN FUEL PUMP AND FUEL PUMP RELAY CONNECTOR. 1) Turn the ignition switch to OFF. 2) Measure the resistance of harness connector between fuel pump and fuel pump relay.</p> <p>Connector & terminal (R58) No. 1 — (B46) No. 4:</p>	Is the resistance less than 1 Ω ?	Go to step 5.	Repair harness and connector. NOTE: In this case, repair the following: <ul style="list-style-type: none"> • Open circuit in harness between fuel pump connector and chassis grounding terminal • Poor contact in coupling connectors
<p>5 CHECK HARNESS BETWEEN FUEL PUMP AND FUEL PUMP RELAY CONNECTOR. Measure the resistance of harness between fuel pump and fuel pump relay connector.</p> <p>Connector & terminal (R58) No. 1 — Chassis ground:</p>	Is the resistance more than 1 M Ω ?	Go to step 6.	Repair short circuit in harness between fuel pump and fuel pump relay connector.

Diagnostics for Engine Starting Failure

ENGINE (DIAGNOSTICS)

Step	Check	Yes	No
6 CHECK FUEL PUMP RELAY. 1) Disconnect the connectors from fuel pump relay and main relay. 2) Remove the fuel pump relay and main relay with bracket. 3) Connect the battery to fuel pump relay connector terminals No. 1 and No. 3. 4) Measure the resistance between connector terminals of fuel pump relay. <i>Terminals</i> <i>No. 2 — No. 4:</i>	Is the resistance less than 10 Ω ?	Go to step 7.	Replace the fuel pump relay. <Ref. to FU(H4SO)-46, Fuel Pump Relay.>
7 CHECK HARNESS BETWEEN ECM AND FUEL PUMP RELAY CONNECTOR. 1) Disconnect the connectors from ECM. 2) Measure the resistance of harness between ECM and fuel pump relay connector. <i>Connector & terminal</i> <i>(B134) No. 11 — (B46) No. 3:</i>	Is the resistance less than 1 Ω ?	Go to step 8.	Repair open circuit in harness between ECM and fuel pump relay connector.
8 CHECK POOR CONTACT. Check poor contact in ECM connector.	Is there poor contact in ECM connector?	Repair poor contact in ECM connector.	Check fuel injector circuit. <Ref. to EN(H4SO)(diag)-69, FUEL INJECTOR CIRCUIT, Diagnostics for Engine Starting Failure.>

F: FUEL INJECTOR CIRCUIT

CAUTION:

- Check or repair only faulty parts.
- After repair or replacement of faulty parts, conduct Clear Memory Mode <Ref. to EN(H4SO)(diag)-44, OPERATION, Clear Memory Mode.> and Inspection Mode <Ref. to EN(H4SO)(diag)-37, OPERATION, Inspection Mode.>

WIRING DIAGRAM:

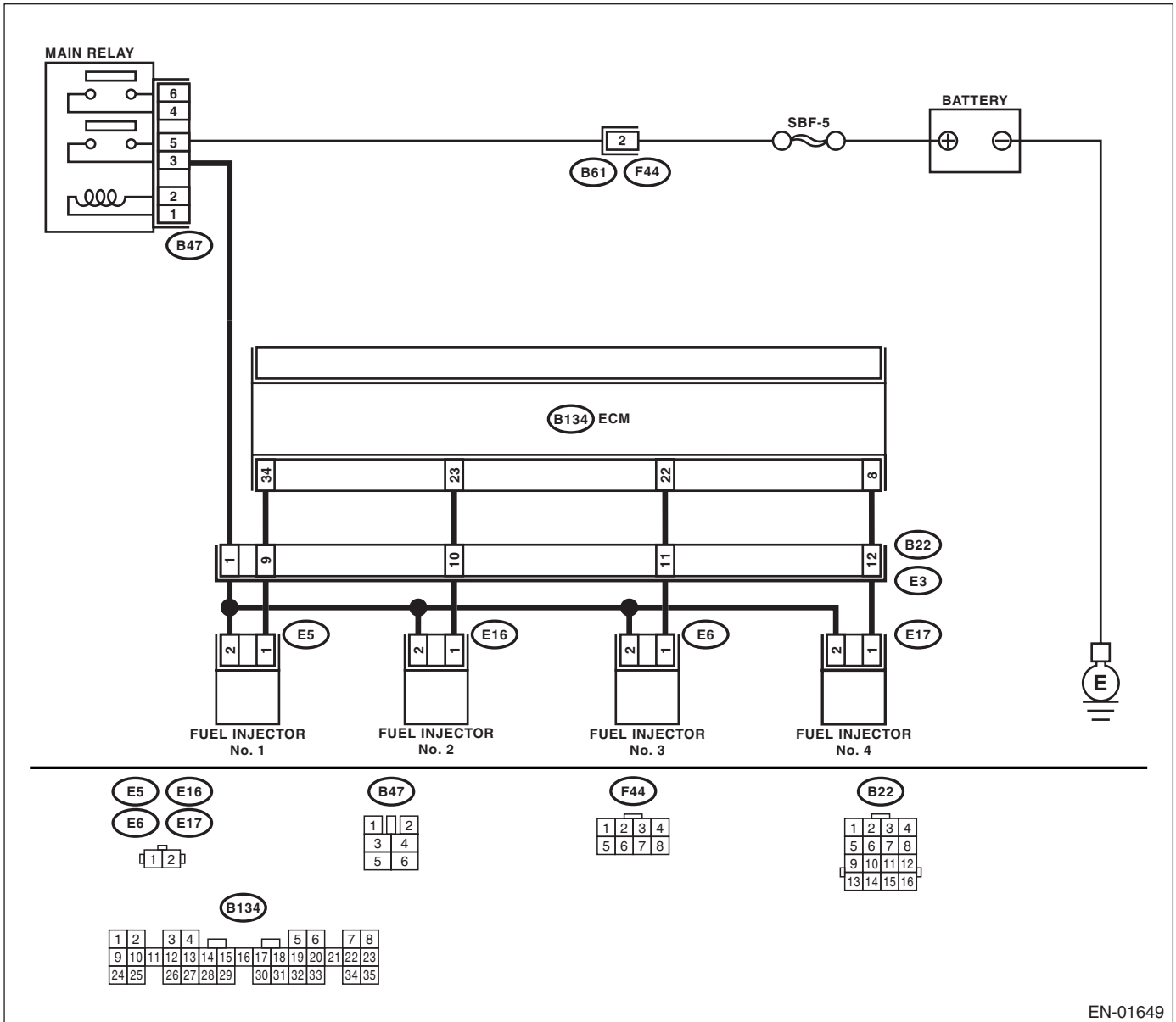

EN-01649

Diagnostics for Engine Starting Failure

ENGINE (DIAGNOSTICS)

Step	Check	Yes	No
1 CHECK OPERATION OF EACH FUEL INJECTOR. While cranking the engine, check that each fuel injector emits "operating" sound. Use a sound scope or attach a screwdriver to the injector for this check.	Dose the fuel injector operate?	Check the fuel pressure. <Ref. to ME(H4SO)-27, INSPECTION, Fuel Pressure.>	Go to step 2.
2 CHECK POWER SUPPLY TO EACH FUEL INJECTOR. 1) Turn the ignition switch to OFF. 2) Disconnect the connector from fuel injector. 3) Turn the ignition switch to ON. 4) Measure the power supply voltage between the fuel injector terminal and engine ground. Connector & terminal <i>#1 (E5) No. 2 (+) — Engine ground (-):</i> <i>#2 (E16) No. 2 (+) — Engine ground (-):</i> <i>#3 (E6) No. 2 (+) — Engine ground (-):</i> <i>#4 (E17) No. 2 (+) — Engine ground (-):</i>	Is the voltage more than 10 V?	Go to step 3.	Repair harness and connector. NOTE: In this case, repair the following: <ul style="list-style-type: none"> • Open circuit in harness between main relay and fuel injector connector • Poor contact in main relay connector • Poor contact in coupling connector (B22) • Poor contact in fuel injector connector
3 CHECK HARNESS BETWEEN ECM AND FUEL INJECTOR CONNECTOR. 1) Disconnect the connector from ECM. 2) Measure the resistance of harness between ECM and fuel injector connector. Connector & terminal <i>#1 (B134) No. 34 — (E5) No. 1:</i> <i>#2 (B134) No. 23 — (E16) No. 1:</i> <i>#3 (B134) No. 22 — (E6) No. 1:</i> <i>#4 (B134) No. 8 — (E17) No. 1:</i>	Is the resistance less than 1 Ω ?	Go to step 4.	Repair harness and connector. NOTE: In this case, repair the following: <ul style="list-style-type: none"> • Open circuit in harness between ECM and fuel injector connector • Poor contact in coupling connector
4 CHECK HARNESS BETWEEN ECM AND FUEL INJECTOR CONNECTOR. Measure the resistance of harness between ECM and fuel injector connector. Connector & terminal <i>#1 (B134) No. 34 — Chassis ground:</i> <i>#2 (B134) No. 23 — Chassis ground:</i> <i>#3 (B134) No. 22 — Chassis ground:</i> <i>#4 (B134) No. 8 — Chassis ground:</i>	Is the resistance more than 1 $M\Omega$?	Go to step 5.	Repair ground short circuit in harness between ECM and fuel injector connector.
5 CHECK EACH FUEL INJECTOR. 1) Turn the ignition switch to OFF. 2) Measure the resistance between each fuel injector terminals. Terminals <i>No. 1 — No. 2:</i>	Is the resistance 5 — 20 Ω ?	Go to step 6.	Replace the faulty fuel injector.
6 CHECK POOR CONTACT. Check poor contact in ECM connector.	Is there poor contact in ECM connector?	Repair poor contact in ECM connector.	Inspection using "General Diagnostic Table". <Ref. to EN(H4SO)(diag)-304, INSPECTION, General Diagnostic Table.>

List of Diagnostic Trouble Code (DTC)

ENGINE (DIAGNOSTICS)

18. List of Diagnostic Trouble Code (DTC)

A: LIST

DTC	Item	Index
P0030	HO2S Heater Control Circuit (Bank 1 Sensor 1)	<Ref. to EN(H4SO)(diag)-78, DTC P0030 HO2S HEATER CONTROL CIRCUIT (BANK 1 SENSOR 1), Diagnostic Procedure with Diagnostic Trouble Code (DTC).>
P0031	HO2S Heater Control Circuit Low (Bank 1 Sensor 1)	<Ref. to EN(H4SO)(diag)-80, DTC P0031 HO2S HEATER CONTROL CIRCUIT LOW (BANK 1 SENSOR 1), Diagnostic Procedure with Diagnostic Trouble Code (DTC).>
P0032	HO2S Heater Control Circuit High (Bank 1 Sensor 1)	<Ref. to EN(H4SO)(diag)-83, DTC P0032 HO2S HEATER CONTROL CIRCUIT HIGH (BANK 1 SENSOR 1), Diagnostic Procedure with Diagnostic Trouble Code (DTC).>
P0037	HO2S Heater Control Circuit Low (Bank 1 Sensor 2)	<Ref. to EN(H4SO)(diag)-85, DTC P0037 HO2S HEATER CONTROL CIRCUIT LOW (BANK 1 SENSOR 2), Diagnostic Procedure with Diagnostic Trouble Code (DTC).>
P0038	HO2S Heater Control Circuit High (Bank 1 Sensor 2)	<Ref. to EN(H4SO)(diag)-88, DTC P0038 HO2S HEATER CONTROL CIRCUIT HIGH (BANK 1 SENSOR 2), Diagnostic Procedure with Diagnostic Trouble Code (DTC).>
P0065	Air Assisted Injector Control Range/Performance	<Ref. to EN(H4SO)(diag)-90, DTC P0065 AIR ASSISTED INJECTOR CONTROL RANGE/PERFORMANCE, Diagnostic Procedure with Diagnostic Trouble Code (DTC).>
P0066	Air Assisted Injector Control Circuit or Circuit Low	<Ref. to EN(H4SO)(diag)-92, DTC P0066 AIR ASSISTED INJECTOR CONTROL CIRCUIT OR CIRCUIT LOW, Diagnostic Procedure with Diagnostic Trouble Code (DTC).>
P0067	Air Assisted Injector Control Circuit High	<Ref. to EN(H4SO)(diag)-94, DTC P0067 AIR ASSISTED INJECTOR CONTROL CIRCUIT HIGH, Diagnostic Procedure with Diagnostic Trouble Code (DTC).>
P0068	Manifold Absolute Pressure/Barometric Pressure Circuit Range/Performance Problem	<Ref. to EN(H4SO)(diag)-96, DTC P0068 MANIFOLD ABSOLUTE PRESSURE/BAROMETRIC PRESSURE CIRCUIT RANGE/PERFORMANCE PROBLEM, Diagnostic Procedure with Diagnostic Trouble Code (DTC).>
P0107	Manifold Absolute Pressure/Barometric Pressure Circuit Low Input	<Ref. to EN(H4SO)(diag)-98, DTC P0107 MANIFOLD ABSOLUTE PRESSURE/BAROMETRIC PRESSURE CIRCUIT LOW INPUT, Diagnostic Procedure with Diagnostic Trouble Code (DTC).>
P0108	Manifold Absolute Pressure/Barometric Pressure Circuit High Input	<Ref. to EN(H4SO)(diag)-101, DTC P0108 MANIFOLD ABSOLUTE PRESSURE/BAROMETRIC PRESSURE CIRCUIT HIGH INPUT, Diagnostic Procedure with Diagnostic Trouble Code (DTC).>
P0111	Intake Air Temperature Circuit Range/Performance	<Ref. to EN(H4SO)(diag)-104, DTC P0111 INTAKE AIR TEMPERATURE CIRCUIT RANGE/PERFORMANCE, Diagnostic Procedure with Diagnostic Trouble Code (DTC).>
P0112	Intake Air Temperature Circuit Low Input	<Ref. to EN(H4SO)(diag)-106, DTC P0112 INTAKE AIR TEMPERATURE CIRCUIT LOW INPUT, Diagnostic Procedure with Diagnostic Trouble Code (DTC).>
P0113	Intake Air Temperature Circuit High Input	<Ref. to EN(H4SO)(diag)-108, DTC P0113 INTAKE AIR TEMPERATURE CIRCUIT HIGH INPUT, Diagnostic Procedure with Diagnostic Trouble Code (DTC).>
P0117	Engine Coolant Temperature Circuit Low Input	<Ref. to EN(H4SO)(diag)-111, DTC P0117 ENGINE COOLANT TEMPERATURE CIRCUIT LOW INPUT, Diagnostic Procedure with Diagnostic Trouble Code (DTC).>
P0118	Engine Coolant Temperature Circuit High Input	<Ref. to EN(H4SO)(diag)-113, DTC P0118 ENGINE COOLANT TEMPERATURE CIRCUIT HIGH INPUT, Diagnostic Procedure with Diagnostic Trouble Code (DTC).>
P0121	Throttle/Pedal Position Sensor/Switch "A" Circuit Range/Performance	<Ref. to EN(H4SO)(diag)-116, DTC P0121 THROTTLE/PEDAL POSITION SENSOR/SWITCH "A" CIRCUIT RANGE/PERFORMANCE, Diagnostic Procedure with Diagnostic Trouble Code (DTC).>
P0122	Throttle/Pedal Position Sensor/Switch "A" Circuit Low Input	<Ref. to EN(H4SO)(diag)-118, DTC P0122 THROTTLE/PEDAL POSITION SENSOR/SWITCH "A" CIRCUIT LOW INPUT, Diagnostic Procedure with Diagnostic Trouble Code (DTC).>

List of Diagnostic Trouble Code (DTC)

ENGINE (DIAGNOSTICS)

DTC	Item	Index
P0123	Throttle/Pedal Position Sensor/Switch "A" Circuit High Input	<Ref. to EN(H4SO)(diag)-121, DTC P0123 THROTTLE/PEDAL POSITION SENSOR/SWITCH "A" CIRCUIT HIGH INPUT, Diagnostic Procedure with Diagnostic Trouble Code (DTC).>
P0125	Insufficient Coolant Temperature for Closed Loop Fuel Control	<Ref. to EN(H4SO)(diag)-123, DTC P0125 INSUFFICIENT COOLANT TEMPERATURE FOR CLOSED LOOP FUEL CONTROL, Diagnostic Procedure with Diagnostic Trouble Code (DTC).>
P0128	Coolant Thermostat (Coolant Temperature Below Thermostat Regulating Temperature)	<Ref. to EN(H4SO)(diag)-125, DTC P0128 COOLANT THERMOSTAT (COOLANT TEMPERATURE BELOW THERMOSTAT REGULATING TEMPERATURE), Diagnostic Procedure with Diagnostic Trouble Code (DTC).>
P0129	Atmospheric Pressure Sensor Circuit Range/Performance	<Ref. to EN(H4SO)(diag)-126, DTC P0129 ATMOSPHERIC PRESSURE SENSOR CIRCUIT RANGE/PERFORMANCE, Diagnostic Procedure with Diagnostic Trouble Code (DTC).>
P0130	O ₂ Sensor Circuit (Bank 1 Sensor 1)	<Ref. to EN(H4SO)(diag)-127, DTC P0130 O ₂ SENSOR CIRCUIT (BANK 1 SENSOR 1), Diagnostic Procedure with Diagnostic Trouble Code (DTC).>
P0131	O ₂ Sensor Circuit Low Voltage (Bank 1 Sensor 1)	<Ref. to EN(H4SO)(diag)-130, DTC P0131 O ₂ SENSOR CIRCUIT LOW VOLTAGE (BANK 1 SENSOR 1), Diagnostic Procedure with Diagnostic Trouble Code (DTC).>
P0132	O ₂ Sensor Circuit High Voltage (Bank 1 Sensor 1)	<Ref. to EN(H4SO)(diag)-132, DTC P0132 O ₂ SENSOR CIRCUIT HIGH VOLTAGE (BANK 1 SENSOR 1), Diagnostic Procedure with Diagnostic Trouble Code (DTC).>
P0133	O ₂ Sensor Circuit Slow Response (Bank 1 Sensor 1)	<Ref. to EN(H4SO)(diag)-134, DTC P0133 O ₂ SENSOR CIRCUIT SLOW RESPONSE (BANK 1 SENSOR 1), Diagnostic Procedure with Diagnostic Trouble Code (DTC).>
P0134	O ₂ Sensor Circuit No Activity Detected (Bank 1 Sensor 1)	<Ref. to EN(H4SO)(diag)-136, DTC P0134 O ₂ SENSOR CIRCUIT NO ACTIVITY DETECTED (BANK 1 SENSOR 1), Diagnostic Procedure with Diagnostic Trouble Code (DTC).>
P0137	O ₂ Sensor Circuit Low Voltage (Bank 1 Sensor 2)	<Ref. to EN(H4SO)(diag)-138, DTC P0137 O ₂ SENSOR CIRCUIT LOW VOLTAGE (BANK 1 SENSOR 2), Diagnostic Procedure with Diagnostic Trouble Code (DTC).>
P0138	O ₂ Sensor Circuit High Voltage (Bank 1 Sensor 2)	<Ref. to EN(H4SO)(diag)-141, DTC P0138 O ₂ SENSOR CIRCUIT HIGH VOLTAGE (BANK 1 SENSOR 2), Diagnostic Procedure with Diagnostic Trouble Code (DTC).>
P0139	O ₂ Sensor Circuit Slow Response (Bank 1 Sensor 2)	<Ref. to EN(H4SO)(diag)-144, DTC P0139 O ₂ SENSOR CIRCUIT SLOW RESPONSE (BANK 1 SENSOR 2), Diagnostic Procedure with Diagnostic Trouble Code (DTC).>
P0171	System too Lean (Bank 1)	<Ref. to EN(H4SO)(diag)-145, DTC P0171 SYSTEM TOO LEAN (BANK 1), Diagnostic Procedure with Diagnostic Trouble Code (DTC).>
P0172	System too Rich (Bank 1)	<Ref. to EN(H4SO)(diag)-146, DTC P0172 SYSTEM TOO RICH (BANK 1), Diagnostic Procedure with Diagnostic Trouble Code (DTC).>
P0181	Fuel Temperature Sensor "A" Circuit Range/Performance	<Ref. to EN(H4SO)(diag)-148, DTC P0181 FUEL TEMPERATURE SENSOR "A" CIRCUIT RANGE/PERFORMANCE, Diagnostic Procedure with Diagnostic Trouble Code (DTC).>
P0182	Fuel Temperature Sensor "A" Circuit Low Input	<Ref. to EN(H4SO)(diag)-150, DTC P0182 FUEL TEMPERATURE SENSOR "A" CIRCUIT LOW INPUT, Diagnostic Procedure with Diagnostic Trouble Code (DTC).>
P0183	Fuel Temperature Sensor "A" Circuit High Input	<Ref. to EN(H4SO)(diag)-152, DTC P0183 FUEL TEMPERATURE SENSOR "A" CIRCUIT HIGH INPUT, Diagnostic Procedure with Diagnostic Trouble Code (DTC).>
P0301	Cylinder 1 Misfire Detected	<Ref. to EN(H4SO)(diag)-154, DTC P0301 CYLINDER 1 MISFIRE DETECTED, Diagnostic Procedure with Diagnostic Trouble Code (DTC).>
P0302	Cylinder 2 Misfire Detected	<Ref. to EN(H4SO)(diag)-154, DTC P0302 CYLINDER 2 MISFIRE DETECTED, Diagnostic Procedure with Diagnostic Trouble Code (DTC).>
P0303	Cylinder 3 Misfire Detected	<Ref. to EN(H4SO)(diag)-154, DTC P0303 CYLINDER 3 MISFIRE DETECTED, Diagnostic Procedure with Diagnostic Trouble Code (DTC).>
P0304	Cylinder 4 Misfire Detected	<Ref. to EN(H4SO)(diag)-155, DTC P0304 CYLINDER 4 MISFIRE DETECTED, Diagnostic Procedure with Diagnostic Trouble Code (DTC).>

List of Diagnostic Trouble Code (DTC)

ENGINE (DIAGNOSTICS)

DTC	Item	Index
P0327	Knock Sensor 1 Circuit Low Input (Bank 1 or Single Sensor)	<Ref. to EN(H4SO)(diag)-162, DTC P0327 KNOCK SENSOR 1 CIRCUIT LOW INPUT (BANK 1 OR SINGLE SENSOR), Diagnostic Procedure with Diagnostic Trouble Code (DTC).>
P0328	Knock Sensor 1 Circuit High Input (Bank 1 or Single Sensor)	<Ref. to EN(H4SO)(diag)-164, DTC P0328 KNOCK SENSOR 1 CIRCUIT HIGH INPUT (BANK 1 OR SINGLE SENSOR), Diagnostic Procedure with Diagnostic Trouble Code (DTC).>
P0335	Crankshaft Position Sensor "A" Circuit	<Ref. to EN(H4SO)(diag)-166, DTC P0335 CRANKSHAFT POSITION SENSOR "A" CIRCUIT, Diagnostic Procedure with Diagnostic Trouble Code (DTC).>
P0336	Crankshaft Position Sensor "A" Circuit Range/Performance	<Ref. to EN(H4SO)(diag)-168, DTC P0336 CRANKSHAFT POSITION SENSOR "A" CIRCUIT RANGE/PERFORMANCE, Diagnostic Procedure with Diagnostic Trouble Code (DTC).>
P0340	Camshaft Position Sensor "A" Circuit (Bank 1 or Single Sensor)	<Ref. to EN(H4SO)(diag)-170, DTC P0340 CAMSHAFT POSITION SENSOR "A" CIRCUIT (BANK 1 OR SINGLE SENSOR), Diagnostic Procedure with Diagnostic Trouble Code (DTC).>
P0341	Camshaft Position Sensor "A" Circuit Range/Performance (Bank 1 or Single Sensor)	<Ref. to EN(H4SO)(diag)-172, DTC P0341 CAMSHAFT POSITION SENSOR "A" CIRCUIT RANGE/PERFORMANCE (BANK 1 OR SINGLE SENSOR), Diagnostic Procedure with Diagnostic Trouble Code (DTC).>
P0420	Catalyst System Efficiency Below Threshold (Bank 1)	<Ref. to EN(H4SO)(diag)-175, DTC P0420 CATALYST SYSTEM EFFICIENCY BELOW THRESHOLD (BANK 1), Diagnostic Procedure with Diagnostic Trouble Code (DTC).>
P0442	Evaporative Emission Control System Leak Detected (small leak)	<Ref. to EN(H4SO)(diag)-176, DTC P0442 EVAPORATIVE EMISSION CONTROL SYSTEM LEAK DETECTED (SMALL LEAK), Diagnostic Procedure with Diagnostic Trouble Code (DTC).>
P0447	Evaporative Emission Control System Vent Control Circuit Open	<Ref. to EN(H4SO)(diag)-180, DTC P0447 EVAPORATIVE EMISSION CONTROL SYSTEM VENT CONTROL CIRCUIT OPEN, Diagnostic Procedure with Diagnostic Trouble Code (DTC).>
P0448	Evaporative Emission Control System Vent Control Circuit Shorted	<Ref. to EN(H4SO)(diag)-183, DTC P0448 EVAPORATIVE EMISSION CONTROL SYSTEM VENT CONTROL CIRCUIT SHORTED, Diagnostic Procedure with Diagnostic Trouble Code (DTC).>
P0451	Evaporative Emission Control System Pressure Sensor Range/Performance	<Ref. to EN(H4SO)(diag)-185, DTC P0451 EVAPORATIVE EMISSION CONTROL SYSTEM PRESSURE SENSOR RANGE/PERFORMANCE, Diagnostic Procedure with Diagnostic Trouble Code (DTC).>
P0452	Evaporative Emission Control System Pressure Sensor Low Input	<Ref. to EN(H4SO)(diag)-187, DTC P0452 EVAPORATIVE EMISSION CONTROL SYSTEM PRESSURE SENSOR LOW INPUT, Diagnostic Procedure with Diagnostic Trouble Code (DTC).>
P0453	Evaporative Emission Control System Pressure Sensor High Input	<Ref. to EN(H4SO)(diag)-190, DTC P0453 EVAPORATIVE EMISSION CONTROL SYSTEM PRESSURE SENSOR HIGH INPUT, Diagnostic Procedure with Diagnostic Trouble Code (DTC).>
P0456	Evaporative Emission Control System Leak Detected (very small leak)	<Ref. to EN(H4SO)(diag)-193, DTC P0456 EVAPORATIVE EMISSION CONTROL SYSTEM LEAK DETECTED (VERY SMALL LEAK), Diagnostic Procedure with Diagnostic Trouble Code (DTC).>
P0457	Evaporative Emission Control System Leak Detected (fuel cap loose/off)	<Ref. to EN(H4SO)(diag)-196, DTC P0457 EVAPORATIVE EMISSION CONTROL SYSTEM LEAK DETECTED (FUEL CAP LOOSE/OFF), Diagnostic Procedure with Diagnostic Trouble Code (DTC).>
P0458	Evaporative Emission Control System Purge Control Valve Circuit Low	<Ref. to EN(H4SO)(diag)-200, DTC P0458 EVAPORATIVE EMISSION CONTROL SYSTEM PURGE CONTROL VALVE CIRCUIT LOW, Diagnostic Procedure with Diagnostic Trouble Code (DTC).>
P0459	Evaporative Emission Control System Purge Control Valve Circuit High	<Ref. to EN(H4SO)(diag)-203, DTC P0459 EVAPORATIVE EMISSION CONTROL SYSTEM PURGE CONTROL VALVE CIRCUIT HIGH, Diagnostic Procedure with Diagnostic Trouble Code (DTC).>
P0461	Fuel Level Sensor Circuit Range/Performance	<Ref. to EN(H4SO)(diag)-205, DTC P0461 FUEL LEVEL SENSOR CIRCUIT RANGE/PERFORMANCE, Diagnostic Procedure with Diagnostic Trouble Code (DTC).>
P0462	Fuel Level Sensor Circuit Low Input	<Ref. to EN(H4SO)(diag)-207, DTC P0462 FUEL LEVEL SENSOR CIRCUIT LOW INPUT, Diagnostic Procedure with Diagnostic Trouble Code (DTC).>

List of Diagnostic Trouble Code (DTC)

ENGINE (DIAGNOSTICS)

DTC	Item	Index
P0463	Fuel Level Sensor Circuit High Input	<Ref. to EN(H4SO)(diag)-210, DTC P0463 FUEL LEVEL SENSOR CIRCUIT HIGH INPUT, Diagnostic Procedure with Diagnostic Trouble Code (DTC).>
P0464	Fuel Level Sensor Circuit Intermittent	<Ref. to EN(H4SO)(diag)-213, DTC P0464 FUEL LEVEL SENSOR CIRCUIT INTERMITTENT, Diagnostic Procedure with Diagnostic Trouble Code (DTC).>
P0483	Cooling Fan Rationality Check	<Ref. to EN(H4SO)(diag)-214, DTC P0483 COOLING FAN RATIONALITY CHECK, Diagnostic Procedure with Diagnostic Trouble Code (DTC).>
P0502	Vehicle Speed Sensor Circuit Low Input	<Ref. to EN(H4SO)(diag)-216, DTC P0502 VEHICLE SPEED SENSOR CIRCUIT LOW INPUT, Diagnostic Procedure with Diagnostic Trouble Code (DTC).>
P0503	Vehicle Speed Sensor Intermittent/Erratic/High	<Ref. to EN(H4SO)(diag)-217, DTC P0503 VEHICLE SPEED SENSOR INTERMITTENT/ERRATIC/HIGH, Diagnostic Procedure with Diagnostic Trouble Code (DTC).>
P0506	Idle Control System RPM Lower Than Expected	<Ref. to EN(H4SO)(diag)-219, DTC P0506 IDLE CONTROL SYSTEM RPM LOWER THAN EXPECTED, Diagnostic Procedure with Diagnostic Trouble Code (DTC).>
P0507	Idle Control System RPM Higher Than Expected	<Ref. to EN(H4SO)(diag)-221, DTC P0507 IDLE CONTROL SYSTEM RPM HIGHER THAN EXPECTED, Diagnostic Procedure with Diagnostic Trouble Code (DTC).>
P0512	Starter Request Circuit	<Ref. to EN(H4SO)(diag)-222, DTC P0512 STARTER REQUEST CIRCUIT, Diagnostic Procedure with Diagnostic Trouble Code (DTC).>
P0519	Idle Control System Malfunction (Fail-Safe)	<Ref. to EN(H4SO)(diag)-225, DTC P0519 IDLE CONTROL SYSTEM MALFUNCTION (FAIL-SAFE), Diagnostic Procedure with Diagnostic Trouble Code (DTC).>
P0565	Cruise Control On Signal	<Ref. to EN(H4SO)(diag)-227, DTC P0565 CRUISE CONTROL ON SIGNAL, Diagnostic Procedure with Diagnostic Trouble Code (DTC).>
P0604	Internal Control Module Random Access Memory (RAM) Error	<Ref. to EN(H4SO)(diag)-229, DTC P0604 INTERNAL CONTROL MODULE RANDOM ACCESS MEMORY (RAM) ERROR, Diagnostic Procedure with Diagnostic Trouble Code (DTC).>
P0691	Cooling Fan 1 Control Circuit Low	<Ref. to EN(H4SO)(diag)-230, DTC P0691 COOLING FAN 1 CONTROL CIRCUIT LOW, Diagnostic Procedure with Diagnostic Trouble Code (DTC).>
P0692	Cooling Fan 1 Control Circuit High	<Ref. to EN(H4SO)(diag)-233, DTC P0692 COOLING FAN 1 CONTROL CIRCUIT HIGH, Diagnostic Procedure with Diagnostic Trouble Code (DTC).>
P0703	Torque Converter/Brake Switch "B" Circuit	<Ref. to EN(H4SO)(diag)-236, DTC P0703 TORQUE CONVERTER/BRAKE SWITCH "B" CIRCUIT, Diagnostic Procedure with Diagnostic Trouble Code (DTC).>
P0705	Transmission Range Sensor Circuit (PRNDL Input)	<Ref. to EN(H4SO)(diag)-238, DTC P0705 TRANSMISSION RANGE SENSOR CIRCUIT (PRNDL INPUT), Diagnostic Procedure with Diagnostic Trouble Code (DTC).>
P0710	Transmission Fluid Temperature Sensor Circuit	<Ref. to EN(H4SO)(diag)-238, DTC P0710 TRANSMISSION FLUID TEMPERATURE SENSOR CIRCUIT, Diagnostic Procedure with Diagnostic Trouble Code (DTC).>
P0716	Torque Converter Turbine Speed Sensor	<Ref. to EN(H4SO)(diag)-238, DTC P0716 OUTPUT/TURBINE SPEED SENSOR CIRCUIT RANGE/PERFORMANCE, Diagnostic Procedure with Diagnostic Trouble Code (DTC).>
P0720	Output Speed Sensor Circuit	<Ref. to EN(H4SO)(diag)-238, DTC P0720 OUTPUT SPEED SENSOR CIRCUIT, Diagnostic Procedure with Diagnostic Trouble Code (DTC).>
P0726	Engine Speed Input Circuit Range/Performance	<Ref. to EN(H4SO)(diag)-238, DTC P0726 ENGINE SPEED INPUT CIRCUIT RANGE/PERFORMANCE, Diagnostic Procedure with Diagnostic Trouble Code (DTC).>
P0731	Gear 1 Incorrect Ratio	<Ref. to EN(H4SO)(diag)-238, DTC P0731 GEAR 1 INCORRECT RATIO, Diagnostic Procedure with Diagnostic Trouble Code (DTC).>
P0732	Gear 2 Incorrect Ratio	<Ref. to EN(H4SO)(diag)-238, DTC P0732 GEAR 2 INCORRECT RATIO, Diagnostic Procedure with Diagnostic Trouble Code (DTC).>
P0733	Gear 3 Incorrect Ratio	<Ref. to EN(H4SO)(diag)-238, DTC P0733 GEAR 3 INCORRECT RATIO, Diagnostic Procedure with Diagnostic Trouble Code (DTC).>

List of Diagnostic Trouble Code (DTC)

ENGINE (DIAGNOSTICS)

DTC	Item	Index
P0734	Gear 4 Incorrect Ratio	<Ref. to EN(H4SO)(diag)-239, DTC P0734 GEAR 4 INCORRECT RATIO, Diagnostic Procedure with Diagnostic Trouble Code (DTC).>
P0741	Torque Converter Clutch Circuit Performance or Stuck Off	<Ref. to EN(H4SO)(diag)-240, DTC P0741 TORQUE CONVERTER CLUTCH CIRCUIT PERFORMANCE OR STUCK OFF, Diagnostic Procedure with Diagnostic Trouble Code (DTC).>
P0743	Torque Converter Clutch Circuit Electrical	<Ref. to EN(H4SO)(diag)-242, DTC P0743 TORQUE CONVERTER CLUTCH CIRCUIT ELECTRICAL, Diagnostic Procedure with Diagnostic Trouble Code (DTC).>
P0748	Pressure Control Solenoid "A" Electrical	<Ref. to EN(H4SO)(diag)-242, DTC P0748 PRESSURE CONTROL SOLENOID "A" ELECTRICAL, Diagnostic Procedure with Diagnostic Trouble Code (DTC).>
P0753	Shift Solenoid "A" Electrical	<Ref. to EN(H4SO)(diag)-242, DTC P0753 SHIFT SOLENOID "A" ELECTRICAL, Diagnostic Procedure with Diagnostic Trouble Code (DTC).>
P0758	Shift Solenoid "B" Electrical	<Ref. to EN(H4SO)(diag)-242, DTC P0758 SHIFT SOLENOID "B" ELECTRICAL, Diagnostic Procedure with Diagnostic Trouble Code (DTC).>
P0771	Shift Solenoid "E" Performance or Stuck Off	<Ref. to EN(H4SO)(diag)-242, DTC P0771 SHIFT SOLENOID "E" PERFORMANCE OR STUCK OFF, Diagnostic Procedure with Diagnostic Trouble Code (DTC).>
P0778	Pressure Control Solenoid "B" Electrical	<Ref. to EN(H4SO)(diag)-242, DTC P0778 PRESSURE CONTROL SOLENOID "B" ELECTRICAL, Diagnostic Procedure with Diagnostic Trouble Code (DTC).>
P0785	Shift/Timing Solenoid	<Ref. to EN(H4SO)(diag)-242, DTC P0785 SHIFT/TIMING SOLENOID, Diagnostic Procedure with Diagnostic Trouble Code (DTC).>
P0851	Neutral Switch Input Circuit Low	<Ref. to EN(H4SO)(diag)-243, DTC P0851 NEUTRAL SWITCH INPUT CIRCUIT LOW, Diagnostic Procedure with Diagnostic Trouble Code (DTC).> <Ref. to EN(H4SO)(diag)-245, DTC P0851 NEUTRAL SWITCH INPUT CIRCUIT LOW (MT MODEL), Diagnostic Procedure with Diagnostic Trouble Code (DTC).>
P0852	Neutral Switch Input Circuit High	<Ref. to EN(H4SO)(diag)-247, DTC P0852 NEUTRAL SWITCH INPUT CIRCUIT HIGH (AT MODEL), Diagnostic Procedure with Diagnostic Trouble Code (DTC).> <Ref. to EN(H4SO)(diag)-250, DTC P0852 NEUTRAL SWITCH INPUT CIRCUIT HIGH (MT MODEL), Diagnostic Procedure with Diagnostic Trouble Code (DTC).>
P0864	TCM Communication Circuit Range/Performance	<Ref. to EN(H4SO)(diag)-253, DTC P0864 TCM COMMUNICATION CIRCUIT RANGE/PERFORMANCE, Diagnostic Procedure with Diagnostic Trouble Code (DTC).>
P0865	TCM Communication Circuit Low	<Ref. to EN(H4SO)(diag)-255, DTC P0865 TCM COMMUNICATION CIRCUIT LOW, Diagnostic Procedure with Diagnostic Trouble Code (DTC).>
P0866	TCM Communication Circuit High	<Ref. to EN(H4SO)(diag)-257, DTC P0866 TCM COMMUNICATION CIRCUIT HIGH, Diagnostic Procedure with Diagnostic Trouble Code (DTC).>
P1110	Atmospheric Pressure Sensor Circuit Malfunction (Low Input)	<Ref. to EN(H4SO)(diag)-259, DTC P1110 ATMOSPHERIC PRESSURE SENSOR CIRCUIT MALFUNCTION (LOW INPUT), Diagnostic Procedure with Diagnostic Trouble Code (DTC).>
P1111	Atmospheric Pressure Sensor Circuit Malfunction (High Input)	<Ref. to EN(H4SO)(diag)-259, DTC P1111 ATMOSPHERIC PRESSURE SENSOR CIRCUIT MALFUNCTION (HIGH INPUT), Diagnostic Procedure with Diagnostic Trouble Code (DTC).>
P1134	A/F Sensor Micro-computer Problem	<Ref. to EN(H4SO)(diag)-260, DTC P1134 A/F SENSOR MICRO-COMPUTER PROBLEM, Diagnostic Procedure with Diagnostic Trouble Code (DTC).>
P1137	O ₂ Sensor Circuit (Lamda=1) (Bank1 Sensor1)	<Ref. to EN(H4SO)(diag)-262, DTC P1137 O ₂ SENSOR CIRCUIT (LAMDA=1) (BANK1 SENSOR1), Diagnostic Procedure with Diagnostic Trouble Code (DTC).>
P1400	Fuel Tank Pressure Control Solenoid Valve Circuit Low	<Ref. to EN(H4SO)(diag)-265, DTC P1400 FUEL TANK PRESSURE CONTROL SOLENOID VALVE CIRCUIT LOW, Diagnostic Procedure with Diagnostic Trouble Code (DTC).>

List of Diagnostic Trouble Code (DTC)

ENGINE (DIAGNOSTICS)

DTC	Item	Index
P1420	Fuel Tank Pressure Control Solenoid Valve Circuit High	<Ref. to EN(H4SO)(diag)-268, DTC P1420 FUEL TANK PRESSURE CONTROL SOLENOID VALVE CIRCUIT HIGH, Diagnostic Procedure with Diagnostic Trouble Code (DTC).>
P1443	Vent Control Solenoid Valve Function Problem	<Ref. to EN(H4SO)(diag)-270, DTC P1443 VENT CONTROL SOLENOID VALVE FUNCTION PROBLEM, Diagnostic Procedure with Diagnostic Trouble Code (DTC).>
P1446	Fuel Tank Sensor Control Valve Circuit Low	<Ref. to EN(H4SO)(diag)-272, DTC P1446 FUEL TANK SENSOR CONTROL VALVE CIRCUIT LOW, Diagnostic Procedure with Diagnostic Trouble Code (DTC).>
P1447	Fuel Tank Sensor Control Valve Circuit High	<Ref. to EN(H4SO)(diag)-275, DTC P1447 FUEL TANK SENSOR CONTROL VALVE CIRCUIT HIGH, Diagnostic Procedure with Diagnostic Trouble Code (DTC).>
P1448	Fuel Tank Sensor Control Valve Range/Performance Problem	<Ref. to EN(H4SO)(diag)-277, DTC P1448 FUEL TANK SENSOR CONTROL VALVE RANGE/PERFORMANCE PROBLEM, Diagnostic Procedure with Diagnostic Trouble Code (DTC).>
P1510	ISC Solenoid Valve Signal #1 Circuit Malfunction (Low Input)	<Ref. to EN(H4SO)(diag)-279, DTC P1510 ISC SOLENOID VALVE SIGNAL #1 CIRCUIT MALFUNCTION (LOW INPUT), Diagnostic Procedure with Diagnostic Trouble Code (DTC).>
P1511	ISC Solenoid Valve Signal #1 Circuit Malfunction (High Input)	<Ref. to EN(H4SO)(diag)-279, DTC P1511 ISC SOLENOID VALVE SIGNAL #1 CIRCUIT MALFUNCTION (HIGH INPUT), Diagnostic Procedure with Diagnostic Trouble Code (DTC).>
P1512	ISC Solenoid Valve Signal #2 Circuit Malfunction (Low Input)	<Ref. to EN(H4SO)(diag)-279, DTC P1512 ISC SOLENOID VALVE SIGNAL #2 CIRCUIT MALFUNCTION (LOW INPUT), Diagnostic Procedure with Diagnostic Trouble Code (DTC).>
P1513	ISC Solenoid Valve Signal #2 Circuit Malfunction (High Input)	<Ref. to EN(H4SO)(diag)-279, DTC P1513 ISC SOLENOID VALVE SIGNAL #2 CIRCUIT MALFUNCTION (HIGH INPUT), Diagnostic Procedure with Diagnostic Trouble Code (DTC).>
P1514	ISC Solenoid Valve Signal #3 Circuit Malfunction (Low Input)	<Ref. to EN(H4SO)(diag)-279, DTC P1514 ISC SOLENOID VALVE SIGNAL #3 CIRCUIT MALFUNCTION (LOW INPUT), Diagnostic Procedure with Diagnostic Trouble Code (DTC).>
P1515	ISC Solenoid Valve Signal #3 Circuit Malfunction (High Input)	<Ref. to EN(H4SO)(diag)-279, DTC P1515 ISC SOLENOID VALVE SIGNAL #3 CIRCUIT MALFUNCTION (HIGH INPUT), Diagnostic Procedure with Diagnostic Trouble Code (DTC).>
P1516	ISC Solenoid Valve Signal #4 Circuit Malfunction (Low Input)	<Ref. to EN(H4SO)(diag)-280, DTC P1516 ISC SOLENOID VALVE SIGNAL #4 CIRCUIT MALFUNCTION (LOW INPUT), Diagnostic Procedure with Diagnostic Trouble Code (DTC).>
P1517	ISC Solenoid Valve Signal #4 Circuit Malfunction (High Input)	<Ref. to EN(H4SO)(diag)-282, DTC P1517 ISC SOLENOID VALVE SIGNAL #4 CIRCUIT MALFUNCTION (HIGH INPUT), Diagnostic Procedure with Diagnostic Trouble Code (DTC).>
P1518	Starter Switch Circuit Low input	<Ref. to EN(H4SO)(diag)-283, DTC P1518 STARTER SWITCH CIRCUIT LOW INPUT, Diagnostic Procedure with Diagnostic Trouble Code (DTC).>
P1560	Back-up Voltage Circuit Malfunction	<Ref. to EN(H4SO)(diag)-286, DTC P1560 BACK-UP VOLTAGE CIRCUIT MALFUNCTION, Diagnostic Procedure with Diagnostic Trouble Code (DTC).>
P1698	Engine Torque Control Cut Signal Circuit Low Input	<Ref. to EN(H4SO)(diag)-288, DTC P1698 ENGINE TORQUE CONTROL CUT SIGNAL CIRCUIT LOW INPUT, Diagnostic Procedure with Diagnostic Trouble Code (DTC).>
P1699	Engine Torque Control Cut Signal Circuit High Input	<Ref. to EN(H4SO)(diag)-290, DTC P1699 ENGINE TORQUE CONTROL CUT SIGNAL CIRCUIT HIGH INPUT, Diagnostic Procedure with Diagnostic Trouble Code (DTC).>
P1700	Throttle Position Sensor	<Ref. to 4AT(diag)-46, DTC 31 THROTTLE POSITION SENSOR, Diagnostic Procedure with Diagnostic Trouble Code (DTC).>
P1711	Engine Torque Control Signal 1 Circuit Malfunction	<Ref. to EN(H4SO)(diag)-292, DTC P1711 ENGINE TORQUE CONTROL SIGNAL 1 CIRCUIT MALFUNCTION, Diagnostic Procedure with Diagnostic Trouble Code (DTC).>

List of Diagnostic Trouble Code (DTC)

ENGINE (DIAGNOSTICS)

DTC	Item	Index
P1712	Engine Torque Control Signal 2 Circuit Malfunction	<Ref. to EN(H4SO)(diag)-294, DTC P1712 ENGINE TORQUE CONTROL SIGNAL 2 CIRCUIT MALFUNCTION, Diagnostic Procedure with Diagnostic Trouble Code (DTC).>
*P2096	Post Catalyst Fuel Trim System Too Lean Bank 1	<Ref. to EN(H4SO)(diag)-296, DTC P2096 POST CATALYST FUEL TRIM SYSTEM TOO LEAN BANK 1, Diagnostic Procedure with Diagnostic Trouble Code (DTC).>
*P2097	Post Catalyst Fuel Trim System Too Rich Bank 1	<Ref. to EN(H4SO)(diag)-300, DTC P2097 POST CATALYST FUEL TRIM SYSTEM TOO RICH BANK 1, Diagnostic Procedure with Diagnostic Trouble Code (DTC).>

: DTC with can be detected only on OBD mode. <Ref. to EN(H4SO)(diag)-36, Read Diagnostic Trouble Code (DTC).>

Diagnostic Procedure with Diagnostic Trouble Code (DTC)

ENGINE (DIAGNOSTICS)

19. Diagnostic Procedure with Diagnostic Trouble Code (DTC)

A: DTC P0030 HO2S HEATER CONTROL CIRCUIT (BANK 1 SENSOR 1)

DTC DETECTING CONDITION:

- Two consecutive driving cycles with fault
- GENERAL DESCRIPTION <Ref. to GD(H4SO)-8, DTC P0030 HO2S HEATER CONTROL CIRCUIT (BANK 1 SENSOR 1), Diagnostic Trouble Code (DTC) Detecting Criteria.>

CAUTION:

After repair or replacement of faulty parts, conduct Clear Memory Mode <Ref. to EN(H4SO)(diag)-44, OPERATION, Clear Memory Mode.> and Inspection Mode <Ref. to EN(H4SO)(diag)-37, Inspection Mode.>.

WIRING DIAGRAM:

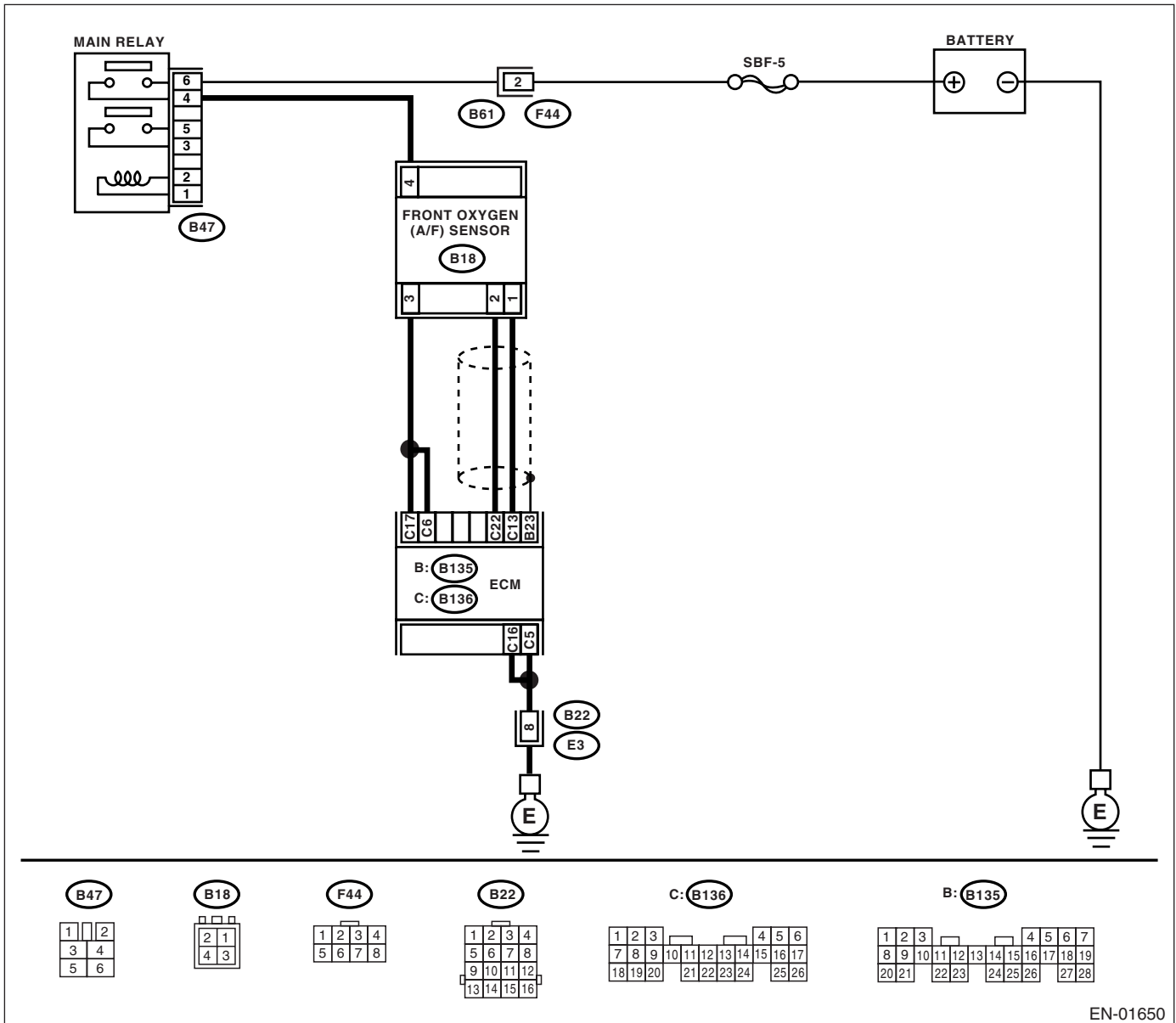

EN-01650

Diagnostic Procedure with Diagnostic Trouble Code (DTC)

ENGINE (DIAGNOSTICS)

Step	Check	Yes	No
<p>1 CHECK HARNESS BETWEEN ECM AND FRONT OXYGEN (A/F) SENSOR CONNECTOR.</p> <p>1) Start the engine and warm-up engine. 2) Turn the ignition switch to OFF. 3) Disconnect the connectors from ECM and front oxygen (A/F) sensor. 4) Measure the resistance of harness between ECM and front oxygen (A/F) sensor connector.</p> <p>Connector & terminal (B136) No. 6 — (B18) No. 3: (B136) No. 17 — (B18) No. 3:</p>	<p>Is the resistance less than 1 Ω?</p>	<p>Go to step 2.</p>	<p>Repair the open circuit in harness between ECM and front oxygen (A/F) sensor connector.</p>
<p>2 CHECK HARNESS BETWEEN ECM AND FRONT OXYGEN (A/F) SENSOR CONNECTOR.</p> <p>Measure the resistance of harness between ECM and front oxygen (A/F) sensor connector.</p> <p>Connector & terminal (B136) No. 13 — (B18) No. 1: (B136) No. 22 — (B18) No. 2:</p>	<p>Is the resistance less than 1 Ω?</p>	<p>Go to step 3.</p>	<p>Repair the open circuit in harness between main relay and front oxygen (A/F) sensor connector.</p>
<p>3 CHECK HARNESS BETWEEN MAIN RELAY AND FRONT OXYGEN (A/F) SENSOR CONNECTOR.</p> <p>Measure the resistance of harness between main relay and front oxygen (A/F) sensor connector.</p> <p>Connector & terminal (B47) No. 4 — (B18) No. 4:</p>	<p>Is the resistance less than 1 Ω?</p>	<p>Go to step 4.</p>	<p>Repair the open circuit in harness between main relay and front oxygen (A/F) sensor connector.</p>
<p>4 CHECK FRONT OXYGEN (A/F) SENSOR.</p> <p>Measure the resistance between front oxygen (A/F) sensor connector terminals.</p> <p>Terminals No. 3 — No. 4:</p>	<p>Is the resistance less than 5 Ω?</p>	<p>Go to step 5.</p>	<p>Replace the front oxygen (A/F) sensor. <Ref. to FU(H4SO)-40, Front Oxygen (A/F) Sensor.></p>
<p>5 CHECK POOR CONTACT.</p> <p>Check the poor contact in ECM and front oxygen (A/F) sensor connector.</p>	<p>Is there poor contact in ECM or front oxygen (A/F) sensor connector?</p>	<p>Repair the poor contact in ECM or front oxygen (A/F) sensor connector.</p>	<p>Replace the front oxygen (A/F) sensor. <Ref. to FU(H4SO)-40, Front Oxygen (A/F) Sensor.></p>

Diagnostic Procedure with Diagnostic Trouble Code (DTC)

ENGINE (DIAGNOSTICS)

B: DTC P0031 HO2S HEATER CONTROL CIRCUIT LOW (BANK 1 SENSOR 1)

DTC DETECTING CONDITION:

- Immediately at fault recognition
- GENERAL DESCRIPTION <Ref. to GD(H4SO)-10, DTC P0031 HO2S HEATER CONTROL CIRCUIT LOW (BANK 1 SENSOR 1), Diagnostic Trouble Code (DTC) Detecting Criteria.>

CAUTION:

After repair or replacement of faulty parts, conduct Clear Memory Mode <Ref. to EN(H4SO)(diag)-44, OPERATION, Clear Memory Mode.> and Inspection Mode <Ref. to EN(H4SO)(diag)-37, OPERATION, Inspection Mode.>.

WIRING DIAGRAM:

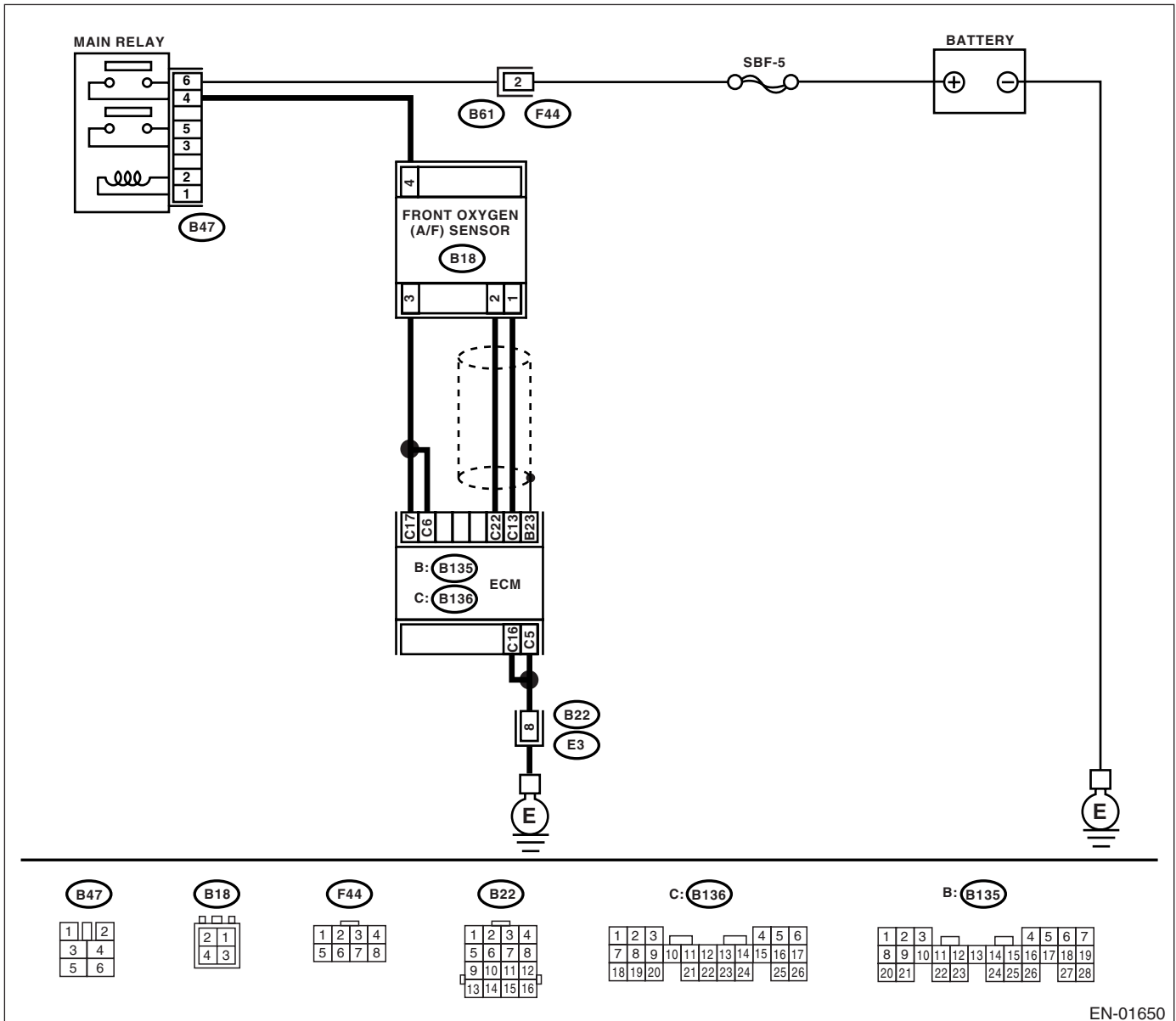

EN-01650

Diagnostic Procedure with Diagnostic Trouble Code (DTC)

ENGINE (DIAGNOSTICS)

Step	Check	Yes	No
1 CHECK ANY OTHER DTC ON DISPLAY.	Does the Subaru Select Monitor or OBD-II general scan tool display DTC P0031 and P0037 at the same time?	Go to step 2.	Go to step 5.
2 CHECK POWER SUPPLY TO FRONT OXYGEN (A/F) SENSOR. 1) Turn the ignition switch to OFF. 2) Disconnect the connector from front oxygen (A/F) sensor. 3) Turn the ignition switch to ON. 4) Measure the voltage between front oxygen (A/F) sensor connector and engine ground. Connector & terminal (B18) No. 4 (+) — Engine ground (-):	Is the voltage more than 10 V?	Go to step 3.	Repair power supply line. NOTE: In this case, repair the following: <ul style="list-style-type: none"> • Open circuit in harness between main relay and front oxygen (A/F) sensor connector • Poor contact in front oxygen (A/F) sensor connector • Poor contact in main relay connector
3 CHECK GROUND CIRCUIT OF ECM. Measure the resistance of harness between ECM connector and chassis ground. Connector & terminal (B136) No. 5 — Chassis ground: (B136) No. 16 — Chassis ground:	Is the resistance less than 5 Ω ?	Go to step 4.	Repair harness and connector. NOTE: In this case, repair the following: <ul style="list-style-type: none"> • Open circuit in harness between ECM and engine ground terminal • Poor contact in ECM connector • Poor contact in coupling connector
4 CHECK CURRENT DATA. 1) Start the engine. 2) Read the data of front oxygen (A/F) sensor heater current using Subaru Select Monitor or OBD-II general scan tool. NOTE: • Subaru Select Monitor For detailed operation procedure, refer to the "READ CURRENT DATA FOR ENGINE". <Ref. to EN(H4SO)(diag)-30, Subaru Select Monitor.> • OBD-II scan tool For detailed operation procedures, refer to the OBD-II General Scan Tool Instruction Manual.	Is the current more than 0.2 A?	Repair poor contact in connector. NOTE: In this case, repair the following: <ul style="list-style-type: none"> • Poor contact in front oxygen (A/F) sensor connector • Poor contact in ECM connector 	Go to step 5.
5 CHECK INPUT SIGNAL FROM ECM. 1) Start and idle the engine. 2) Measure the voltage between ECM connector and chassis ground. Connector & terminal (B136) No. 6 (+) — Chassis ground (-): (B136) No. 17 (+) — Chassis ground (-):	Is the voltage less than 1 V?	Go to step 7.	Go to step 6.
6 CHECK OUTPUT SIGNAL FROM ECM. Measure the voltage between ECM connector and chassis ground. Connector & terminal (B136) No. 6 (+) — Chassis ground (-): (B136) No. 17 (+) — Chassis ground (-):	Does the voltage change by shaking the ECM harness and connector?	Repair poor contact in ECM connector.	Go to step 7.

Diagnostic Procedure with Diagnostic Trouble Code (DTC)

ENGINE (DIAGNOSTICS)

Step	Check	Yes	No
<p>7</p> <p>CHECK FRONT OXYGEN (A/F) SENSOR.</p> <p>1) Turn the ignition switch to OFF.</p> <p>2) Measure the resistance between front oxygen (A/F) sensor connector terminals.</p> <p>Terminals</p> <p>No. 3 — No. 4:</p>	<p>Is the resistance less than 10 Ω?</p>	<p>Repair harness and connector.</p> <p>NOTE: In this case, repair the following:</p> <ul style="list-style-type: none">• Open or ground short circuit in harness between front oxygen (A/F) sensor and ECM connector• Poor contact in front oxygen (A/F) sensor connector• Poor contact in ECM connector	<p>Replace the front oxygen (A/F) sensor. <Ref. to FU(H4SO)-40, Front Oxygen (A/F) Sensor.></p>

Diagnostic Procedure with Diagnostic Trouble Code (DTC)

ENGINE (DIAGNOSTICS)

C: DTC P0032 HO2S HEATER CONTROL CIRCUIT HIGH (BANK 1 SENSOR 1)

DTC DETECTING CONDITION:

- Immediately at fault recognition
- GENERAL DESCRIPTION <Ref. to GD(H4SO)-12, DTC P0032 HO2S HEATER CONTROL CIRCUIT HIGH (BANK 1 SENSOR 1), Diagnostic Trouble Code (DTC) Detecting Criteria.>

CAUTION:

After repair or replacement of faulty parts, conduct Clear Memory Mode <Ref. to EN(H4SO)(diag)-44, OPERATION, Clear Memory Mode.> and Inspection Mode <Ref. to EN(H4SO)(diag)-37, OPERATION, Inspection Mode.>.

WIRING DIAGRAM:

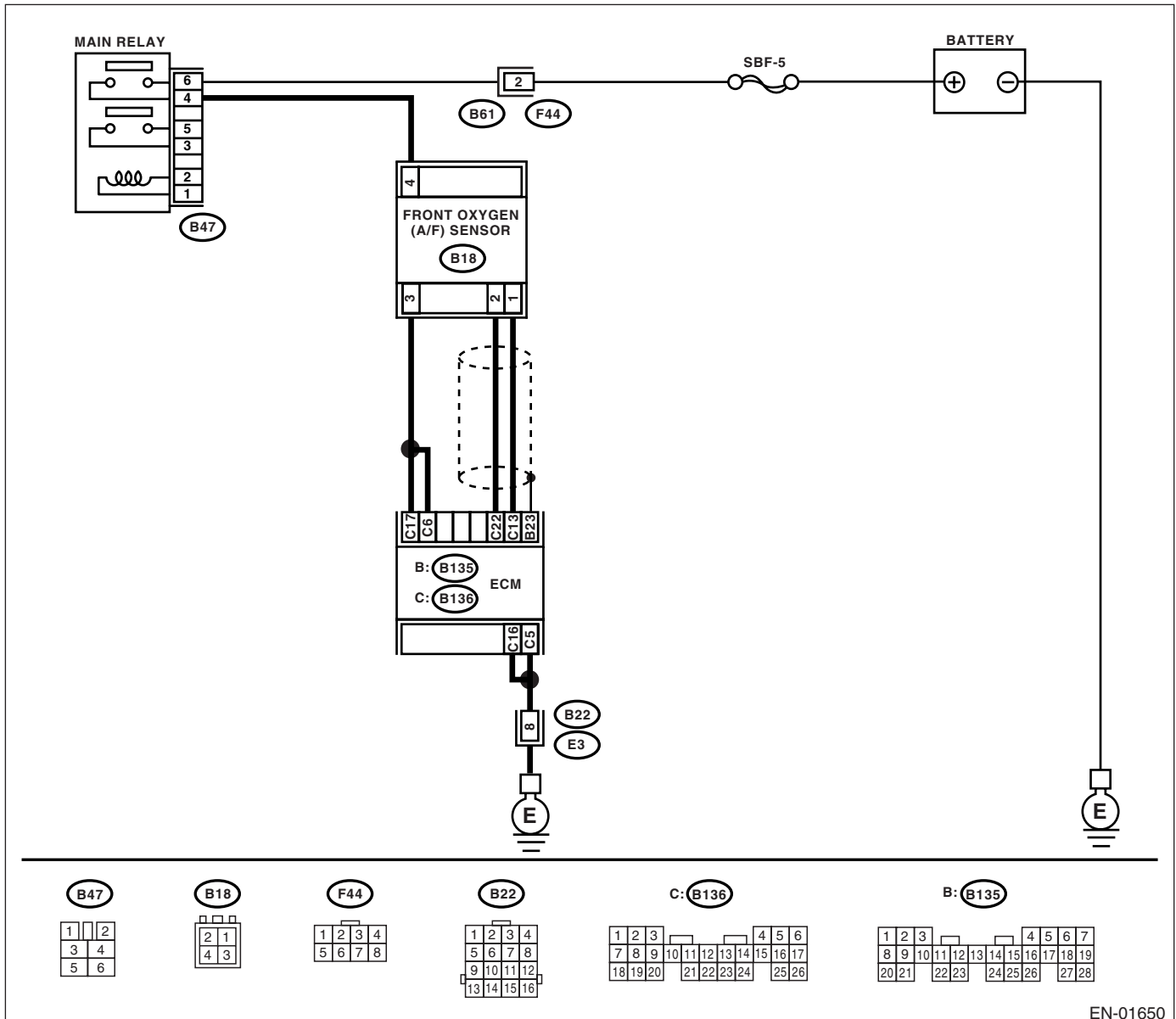

EN-01650

Diagnostic Procedure with Diagnostic Trouble Code (DTC)

ENGINE (DIAGNOSTICS)

Step	Check	Yes	No
1 CHECK OUTPUT SIGNAL FROM ECM. 1) Turn the ignition switch to ON. 2) Measure the voltage between ECM connector and chassis ground. Connector & terminal <i>(B136) No. 6 (+) — Chassis ground (-):</i> <i>(B136) No. 17 (+) — Chassis ground (-):</i>	Is the voltage more than 8 V?	Go to step 2.	Go to step 3.
2 CHECK FRONT OXYGEN (A/F) SENSOR HEATER CURRENT. 1) Turn the ignition switch to OFF. 2) Repair the battery short circuit in harness between ECM and front oxygen (A/F) sensor connector. 3) Turn the ignition switch to ON. 4) Read the data of front oxygen (A/F) sensor heater current using Subaru Select Monitor or the OBD-II general scan tool. NOTE: • Subaru Select Monitor For detailed operation procedure, refer to the "READ CURRENT DATA FOR ENGINE". <Ref. to EN(H4SO)(diag)-30, Subaru Select Monitor.> • OBD-II general scan tool For detailed operation procedure, refer to the OBD-II General Scan Tool Instruction Manual.	Is the current more than 2.3 A?	Replace the ECM. <Ref. to FU(H4SO)-44, Engine Control Module (ECM).>	END
3 CHECK OUTPUT SIGNAL FROM ECM. Measure the voltage between ECM connector and chassis ground. Connector & terminal <i>(B136) No. 6 (+) — Chassis ground (-):</i> <i>(B136) No. 17 (+) — Chassis ground (-):</i>	Does the voltage change by shaking the ECM harness and connector?	Repair battery short circuit in harness between ECM and front oxygen (A/F) sensor connector.	END

Diagnostic Procedure with Diagnostic Trouble Code (DTC)

ENGINE (DIAGNOSTICS)

D: DTC P0037 HO2S HEATER CONTROL CIRCUIT LOW (BANK 1 SENSOR 2)

DTC DETECTING CONDITION:

- Two consecutive driving cycles with fault
- GENERAL DESCRIPTION <Ref. to GD(H4SO)-14, DTC P0037 HO2S HEATER CONTROL CIRCUIT LOW (BANK 1 SENSOR 2), Diagnostic Trouble Code (DTC) Detecting Criteria.>

CAUTION:

After repair or replacement of faulty parts, conduct Clear Memory Mode <Ref. to EN(H4SO)(diag)-44, OPERATION, Clear Memory Mode.> and Inspection Mode <Ref. to EN(H4SO)(diag)-37, OPERATION, Inspection Mode.>.

WIRING DIAGRAM:

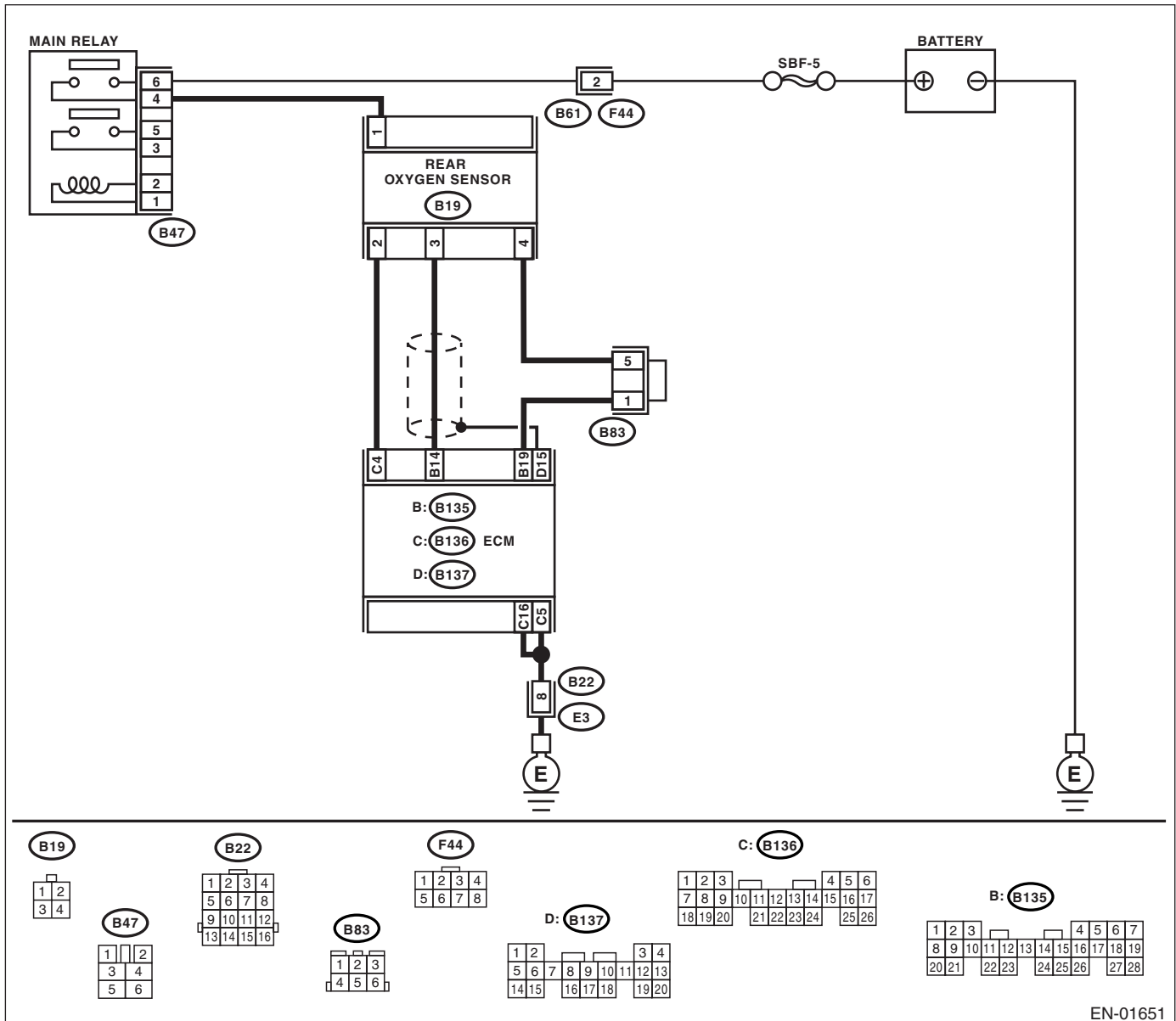

EN-01651

Diagnostic Procedure with Diagnostic Trouble Code (DTC)

ENGINE (DIAGNOSTICS)

Step	Check	Yes	No
<p>1 CHECK GROUND CIRCUIT OF ECM. 1) Turn the ignition switch to OFF. 2) Disconnect the connector from ECM. 3) Measure the resistance of harness between ECM connector and chassis ground. Connector & terminal (B136) No. 5 — Chassis ground: (B136) No. 16 — Chassis ground:</p>	<p>Is the resistance less than 5 Ω?</p>	<p>Go to step 2.</p>	<p>Repair harness and connector. NOTE: In this case, repair the following: • Open circuit in harness between ECM and engine ground terminal • Poor contact in ECM connector • Poor contact in coupling connector</p>
<p>2 CHECK CURRENT DATA. 1) Start the engine. 2) Read the data of rear oxygen sensor heater current using Subaru Select Monitor or OBD-II general scan tool. NOTE: • Subaru Select Monitor For detailed operation procedure, refer to the "READ CURRENT DATA FOR ENGINE". <Ref. to EN(H4SO)(diag)-30, Subaru Select Monitor.> • OBD-II scan tool For detailed operation procedures, refer to the OBD-II General Scan Tool Instruction Manual.</p>	<p>Is the current more than 0.2 A?</p>	<p>Repair the connector. NOTE: In this case, repair the following: • Poor contact in rear oxygen sensor connector • Poor contact in rear oxygen sensor connecting harness connector • Poor contact in ECM connector</p>	<p>Go to step 3.</p>
<p>3 CHECK OUTPUT SIGNAL FROM ECM. 1) Start and idle the engine. 2) Measure the voltage between ECM connector and chassis ground. Connector & terminal (B136) No. 4 (+) — Chassis ground (-):</p>	<p>Is the voltage less than 1 V?</p>	<p>Go to step 6.</p>	<p>Go to step 4.</p>
<p>4 CHECK OUTPUT SIGNAL FROM ECM. Measure the voltage between ECM connector and chassis ground. Connector & terminal (B136) No. 4 (+) — Chassis ground (-):</p>	<p>Does the voltage change by shaking the ECM harness and connector?</p>	<p>Repair poor contact in ECM connector.</p>	<p>Go to step 5.</p>
<p>5 CHECK OUTPUT SIGNAL FROM ECM. 1) Disconnect the connector from rear oxygen sensor. 2) Measure the voltage between ECM connector and chassis ground. Connector & terminal (B136) No. 4 (+) — Chassis ground (-):</p>	<p>Is the voltage less than 1 V?</p>	<p>Replace the ECM. <Ref. to FU(H4SO)-44, Engine Control Module (ECM).></p>	<p>Repair battery short circuit in harness between ECM and rear oxygen sensor connector. After repair, replace the ECM. <Ref. to FU(H4SO)-44, Engine Control Module (ECM).></p>

Diagnostic Procedure with Diagnostic Trouble Code (DTC)

ENGINE (DIAGNOSTICS)

Step	Check	Yes	No
<p>6</p> <p>CHECK POWER SUPPLY TO REAR OXYGEN SENSOR.</p> <p>1) Turn the ignition switch to OFF. 2) Disconnect the connector from rear oxygen sensor. 3) Turn the ignition switch to ON. 4) Measure the voltage between rear oxygen sensor connector and engine ground or chassis ground.</p> <p>Connector & terminal (B19) No. 1 (+) — Chassis ground (-):</p>	<p>Is the voltage more than 10 V?</p>	<p>Go to step 7.</p>	<p>Repair power supply line.</p> <p>NOTE: In this case, repair the following:</p> <ul style="list-style-type: none"> • Open circuit in harness between main relay and rear oxygen sensor connector • Poor contact in rear oxygen sensor connector • Poor contact in coupling connector
<p>7</p> <p>CHECK REAR OXYGEN SENSOR.</p> <p>1) Turn the ignition switch to OFF. 2) Measure the resistance between rear oxygen sensor connector terminals.</p> <p>Terminals No. 1 — No. 2:</p>	<p>Is the resistance less than 30 Ω?</p>	<p>Repair harness and connector.</p> <p>NOTE: In this case, repair the following:</p> <ul style="list-style-type: none"> • Open circuit in harness between rear oxygen sensor and ECM connector • Poor contact in rear oxygen sensor connector • Poor contact in ECM connector • Poor contact in coupling connector 	<p>Replace the rear oxygen sensor.</p> <p><Ref. to FU(H4SO)-42, Rear Oxygen Sensor.></p>

Diagnostic Procedure with Diagnostic Trouble Code (DTC)

ENGINE (DIAGNOSTICS)

E: DTC P0038 HO2S HEATER CONTROL CIRCUIT HIGH (BANK 1 SENSOR 2)

DTC DETECTING CONDITION:

- Two consecutive driving cycles with fault
- GENERAL DESCRIPTION <Ref. to GD(H4SO)-16, DTC P0038 HO2S HEATER CONTROL CIRCUIT HIGH (BANK 1 SENSOR 2), Diagnostic Trouble Code (DTC) Detecting Criteria.>

CAUTION:

After repair or replacement of faulty parts, conduct Clear Memory Mode <Ref. to EN(H4SO)(diag)-44, OPERATION, Clear Memory Mode.> and Inspection Mode <Ref. to EN(H4SO)(diag)-37, OPERATION, Inspection Mode.>.

WIRING DIAGRAM:

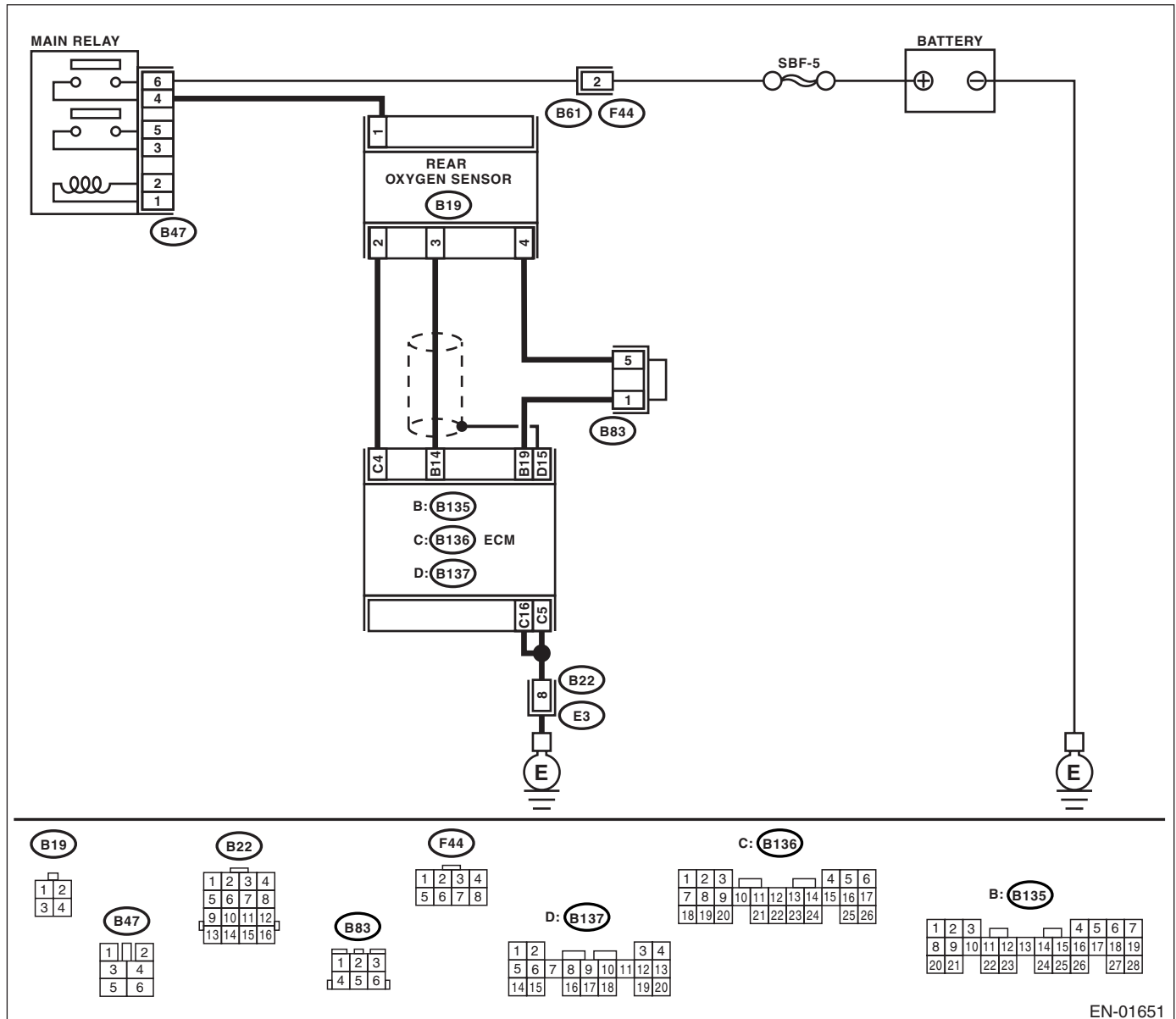

EN-01651

Diagnostic Procedure with Diagnostic Trouble Code (DTC)

ENGINE (DIAGNOSTICS)

Step	Check	Yes	No
1 CHECK INPUT SIGNAL FOR ECM. Measure the voltage between ECM connector and chassis ground. <i>Connector & terminal</i> <i>(B136) No. 4 (+) — Chassis ground (-):</i>	Is the voltage more than 8 V?	Go to step 2.	Go to step 3.
2 CHECK CURRENT DATA. 1) Turn the ignition switch to OFF. 2) Repair the battery short circuit in harness between ECM and rear oxygen sensor connector. 3) Turn the ignition switch to ON. 4) Read the data of rear oxygen sensor heater current using Subaru Select Monitor or the OBD-II general scan tool. NOTE: • Subaru Select Monitor For detailed operation procedure, refer to the "READ CURRENT DATA FOR ENGINE". <Ref. to EN(H4SO)(diag)-30, Subaru Select Monitor.> • OBD-II general scan tool For detailed operation procedure, refer to the OBD-II General Scan Tool Instruction Manual.	Is the current more than 7 A?	Replace the ECM. <Ref. to FU(H4SO)-44, Engine Control Module (ECM).>	END
3 CHECK POOR CONTACT. Check poor contact in ECM connector.	Is there poor contact in ECM connector?	Repair poor contact in ECM connector.	END

Diagnostic Procedure with Diagnostic Trouble Code (DTC)

ENGINE (DIAGNOSTICS)

	Step	Check	Yes	No
1	CHECK FOR OTHER DTC ON DISPLAY.	Is any other DTC displayed?	Inspect DTC using "List of Diagnostic Trouble Code (DTC)". <Ref. to EN(H4SO)(diag)-71, List of Diagnostic Trouble Code (DTC).>	Go to step 2.
2	CHECK AIR ASSISTED INJECTOR SOLENOID VALVE OPERATION. 1) Turn ignition switch to OFF. 2) Connect the test mode connector at the lower portion of instrument panel (on the driver's side). 3) Turn ignition switch to ON. 4) Operate the air assisted injector solenoid valve. NOTE: Air assisted injector solenoid valve operation can also be executed using Subaru Select Monitor. For the procedure, refer to "Compulsory Valve Operation Check Mode". <Ref. to EN(H4SO)(diag)-71, List of Diagnostic Trouble Code (DTC).>	Does air assisted injector solenoid valve operate?	Go to step 3.	Replace the air assisted injector solenoid valve. <Ref. to FU(H4SO)-33, Air Assist Injector Solenoid Valve.>
3	CHECK AIR BYPASS HOSES. Use your mouth to blow through the air bypass hose to make sure that there is a smooth air flow (no clogging).	Is there damage or clog at air bypass hose?	Repair or replace the air bypass hoses.	Go to step 4.
4	CHECK FUEL INJECTOR. 1) Turn ignition switch to OFF. 2) Remove the fuel injector. <Ref. to FU(H4SO)-34, REMOVAL, Fuel Injector.> 3) Check for clogged fuel injectors.	Is the fuel injector clogged?	Replace the fuel injector. <Ref. to FU(H4SO)-37, INSTALLATION, Fuel Injector.>	Replace the air assisted injector solenoid valve. <Ref. to FU(H4SO)-33, Air Assist Injector Solenoid Valve.>

Diagnostic Procedure with Diagnostic Trouble Code (DTC)

ENGINE (DIAGNOSTICS)

G: DTC P0066 AIR ASSISTED INJECTOR CONTROL CIRCUIT OR CIRCUIT LOW

DTC DETECTING CONDITION:

- Two consecutive driving cycles with fault
- GENERAL DESCRIPTION <Ref. to GD(H4SO)-21, DTC P0066 AIR ASSISTED INJECTOR CONTROL CIRCUIT OR CIRCUIT LOW, Diagnostic Trouble Code (DTC) Detecting Criteria.>

TROUBLE SYMPTOM:

- Erroneous idling
- Engine stalls

CAUTION:

After repair or replacement of faulty parts, conduct Clear Memory Mode <Ref. to EN(H4SO)(diag)-44, OPERATION, Clear Memory Mode.> and Inspection Mode <Ref. to EN(H4SO)(diag)-37, OPERATION, Inspection Mode.>.

WIRING DIAGRAM:

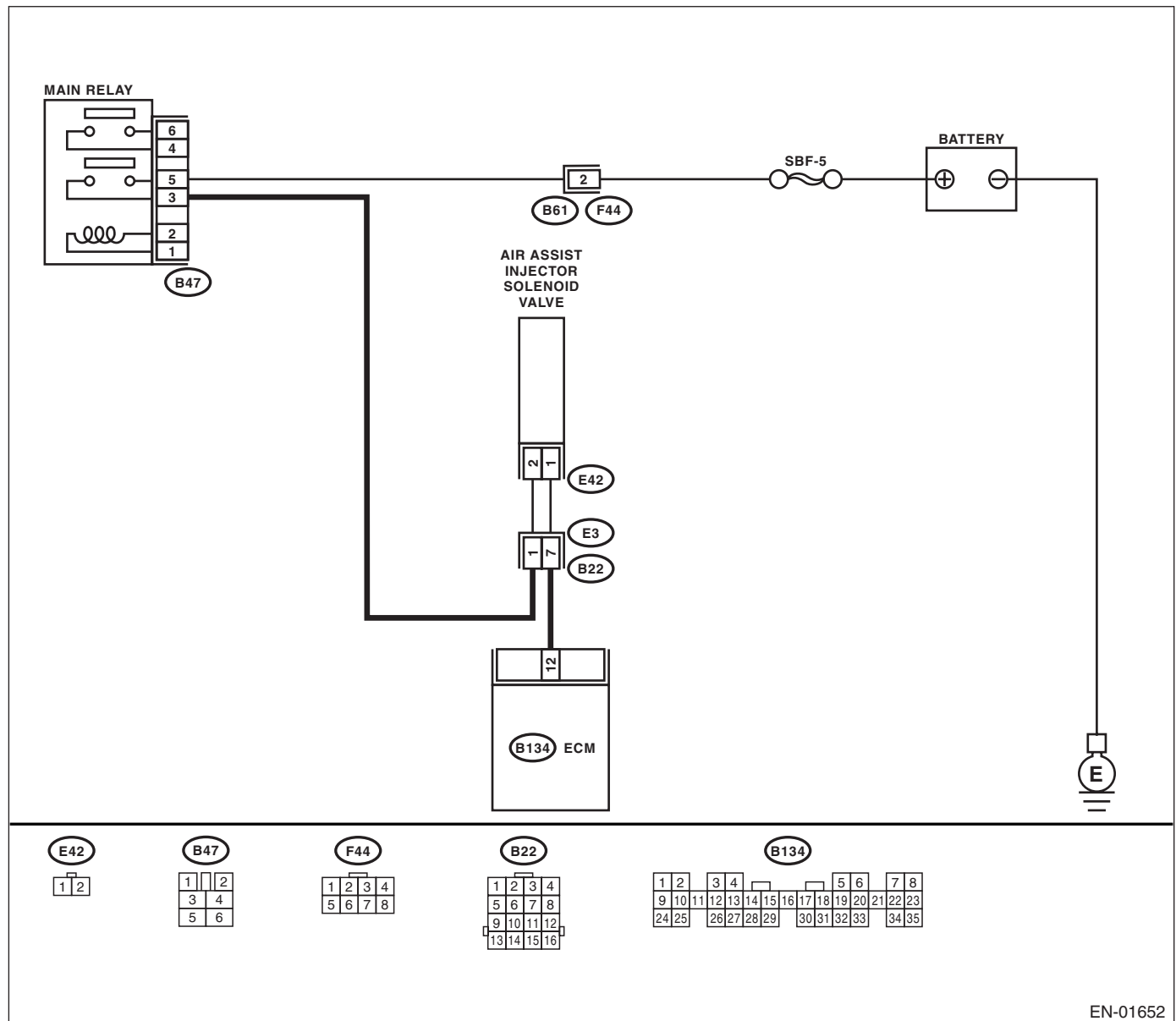

EN-01652

Diagnostic Procedure with Diagnostic Trouble Code (DTC)

ENGINE (DIAGNOSTICS)

Step	Check	Yes	No
1 CHECK OUTPUT SIGNAL FROM ECM. 1) Turn ignition switch to ON. 2) Measure voltage between ECM and chassis ground. <i>Connector & terminal</i> <i>(B134) No. 12 (+) — Chassis ground (-):</i>	Is the voltage more than 10 V?	Repair poor contact in ECM connector.	Go to step 2.
2 CHECK POWER SUPPLY TO AIR ASSIST INJECTOR SOLENOID VALVE. 1) Turn ignition switch to OFF. 2) Disconnect connector from air assist injector solenoid valve. 3) Turn ignition switch to ON. 4) Measure voltage between air assist injector solenoid valve and engine ground. <i>Connector & terminal</i> <i>(E42) No. 2 (+) — Engine ground (-):</i>	Is the voltage more than 10 V?	Go to step 3.	Repair harness and connector. NOTE: In this case, repair the following: <ul style="list-style-type: none"> • Open circuit in harness between air assist injector solenoid valve and main relay connector • Poor contact in coupling connector
3 CHECK HARNESS BETWEEN ECM AND AIR ASSIST INJECTOR SOLENOID VALVE CONNECTOR. 1) Turn ignition switch to OFF. 2) Disconnect connector from ECM. 3) Measure resistance of harness between ECM and air assist injector solenoid valve connector. <i>Connector & terminal</i> <i>(B134) No. 12 — (E42) No. 1:</i>	Is the resistance less than 1 Ω ?	Go to step 4.	Repair harness and connector. NOTE: In this case, repair the following: <ul style="list-style-type: none"> • Open circuit in harness between ECM and air assist injector solenoid valve connector • Poor contact in coupling connector
4 CHECK HARNESS BETWEEN ECM AND AIR ASSIST INJECTOR SOLENOID VALVE CONNECTOR. Measure resistance of harness between ECM and chassis ground. <i>Connector & terminal</i> <i>(B134) No. 12 — Chassis ground:</i>	Is the resistance more than 1 $M\Omega$?	Go to step 5.	Repair ground short circuit in harness between ECM and air assist injector solenoid valve connector.
5 CHECK POOR CONTACT. Check poor contact in ECM and air assist injector solenoid valve connectors.	Is there poor contact in ECM and air assist injector solenoid valve connectors?	Repair poor contact in ECM and air assist injector solenoid valve connectors.	Replace air assist injector solenoid valve. <Ref. to FU(H4SO)-33, Air Assist Injector Solenoid Valve.>

Diagnostic Procedure with Diagnostic Trouble Code (DTC)

ENGINE (DIAGNOSTICS)

H: DTC P0067 AIR ASSISTED INJECTOR CONTROL CIRCUIT HIGH

DTC DETECTING CONDITION:

- Two consecutive driving cycles with fault
- GENERAL DESCRIPTION <Ref. to GD(H4SO)-23, DTC P0067 AIR ASSISTED INJECTOR CONTROL CIRCUIT HIGH, Diagnostic Trouble Code (DTC) Detecting Criteria.>

TROUBLE SYMPTOM:

- Erroneous idling
- Engine stalls

CAUTION:

After repair or replacement of faulty parts, conduct Clear Memory Mode <Ref. to EN(H4SO)(diag)-44, OPERATION, Clear Memory Mode.> and Inspection Mode <Ref. to EN(H4SO)(diag)-37, OPERATION, Inspection Mode.>.

WIRING DIAGRAM:

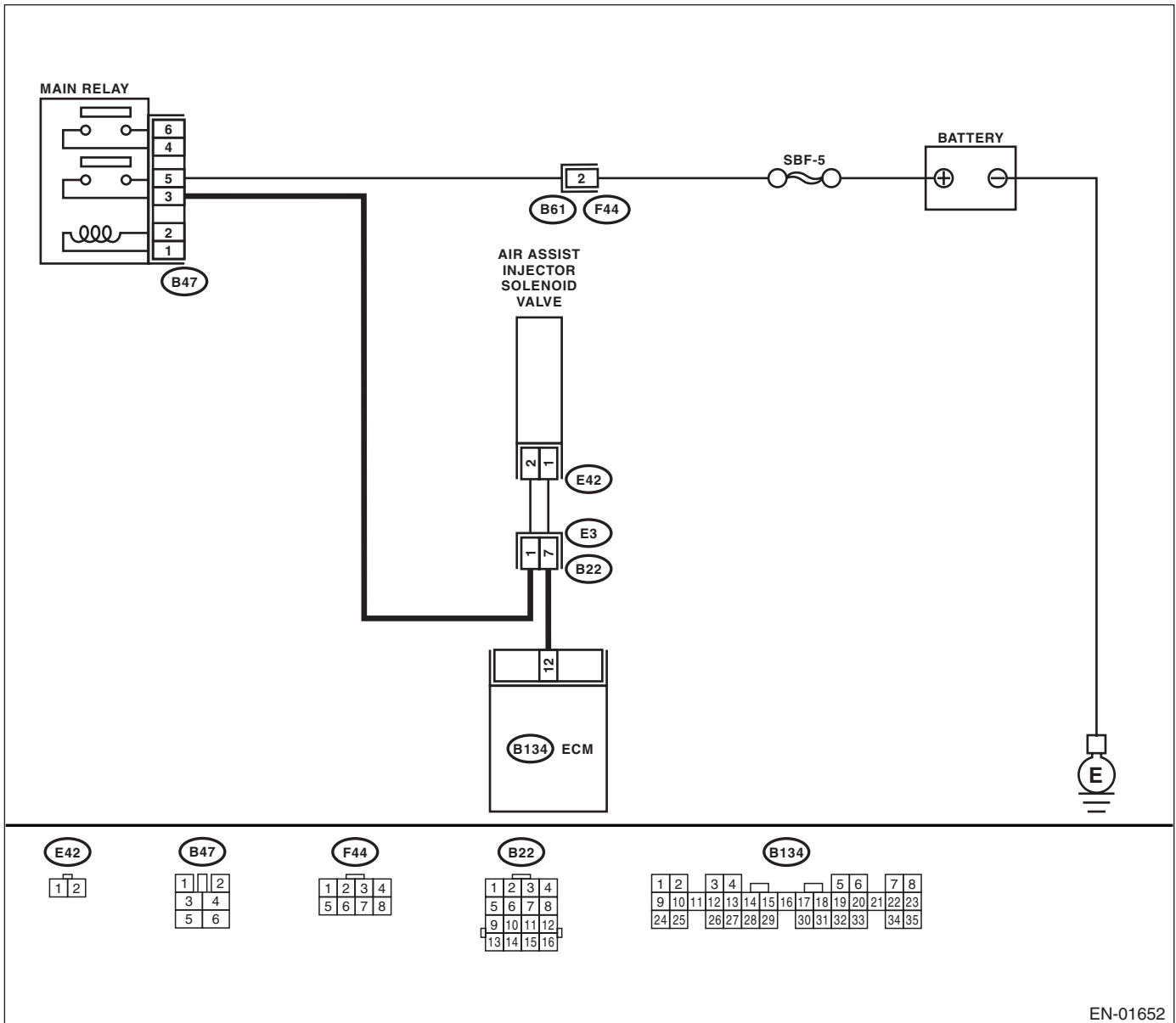

EN-01652

Diagnostic Procedure with Diagnostic Trouble Code (DTC)

ENGINE (DIAGNOSTICS)

Step	Check	Yes	No
1 CHECK OUTPUT SIGNAL FROM ECM. 1) Turn ignition switch to ON. 2) Measure voltage between ECM and chassis ground. Connector & terminal (B134) No. 12 (+) — Chassis ground (-):	Is the voltage more than 10 V?	Go to step 2.	Go to step 3.
2 CHECK OUTPUT SIGNAL FROM ECM. 1) Turn ignition switch to OFF. 2) Disconnect connector from air assist injector solenoid valve. 3) Turn ignition switch to ON. 4) Measure voltage between ECM and chassis ground. Connector & terminal (B134) No. 12 (+) — Chassis ground (-):	Is the voltage more than 10 V?	Repair battery short circuit in harness between ECM and air assist injector solenoid valve connector. After repair, replace ECM. <Ref. to FU(H4SO)-44, Engine Control Module (ECM).>	Replace air assist injector solenoid valve <Ref. to FU(H4SO)-33, Air Assist Injector Solenoid Valve.> and ECM <Ref. to FU(H4SO)-44, Engine Control Module (ECM).>
3 CHECK OUTPUT SIGNAL FROM ECM. Measure voltage between ECM and chassis ground. Connector & terminal (B134) No. 12 (+) — Chassis ground (-):	Does the voltage change by shaking the ECM harness and connector?	Repair battery short circuit in harness between ECM and air assist injector solenoid valve connector. After repair, replace ECM. <Ref. to FU(H4SO)-44, Engine Control Module (ECM).>	Contact SOA Service Center. NOTE: Inspection by DTM is required, because probable cause is deterioration of multiple parts.

Diagnostic Procedure with Diagnostic Trouble Code (DTC)

ENGINE (DIAGNOSTICS)

I: DTC P0068 MANIFOLD ABSOLUTE PRESSURE/BAROMETRIC PRESSURE CIRCUIT RANGE/PERFORMANCE PROBLEM

DTC DETECTING CONDITION:

- Two consecutive driving cycles with fault
- GENERAL DESCRIPTION <Ref. to GD(H4SO)-25, DTC P0068 MANIFOLD PRESSURE SENSOR RANGE/PERFORMANCE, Diagnostic Trouble Code (DTC) Detecting Criteria.>

CAUTION:

After repair or replacement of faulty parts, conduct CLEAR MEMORY MODE <Ref. to EN(H4SO)(diag)-44, OPERATION, Clear Memory Mode.> and INSPECTION MODE <Ref. to EN(H4SO)(diag)-37, OPERATION, Inspection Mode.>.

WIRING DIAGRAM:

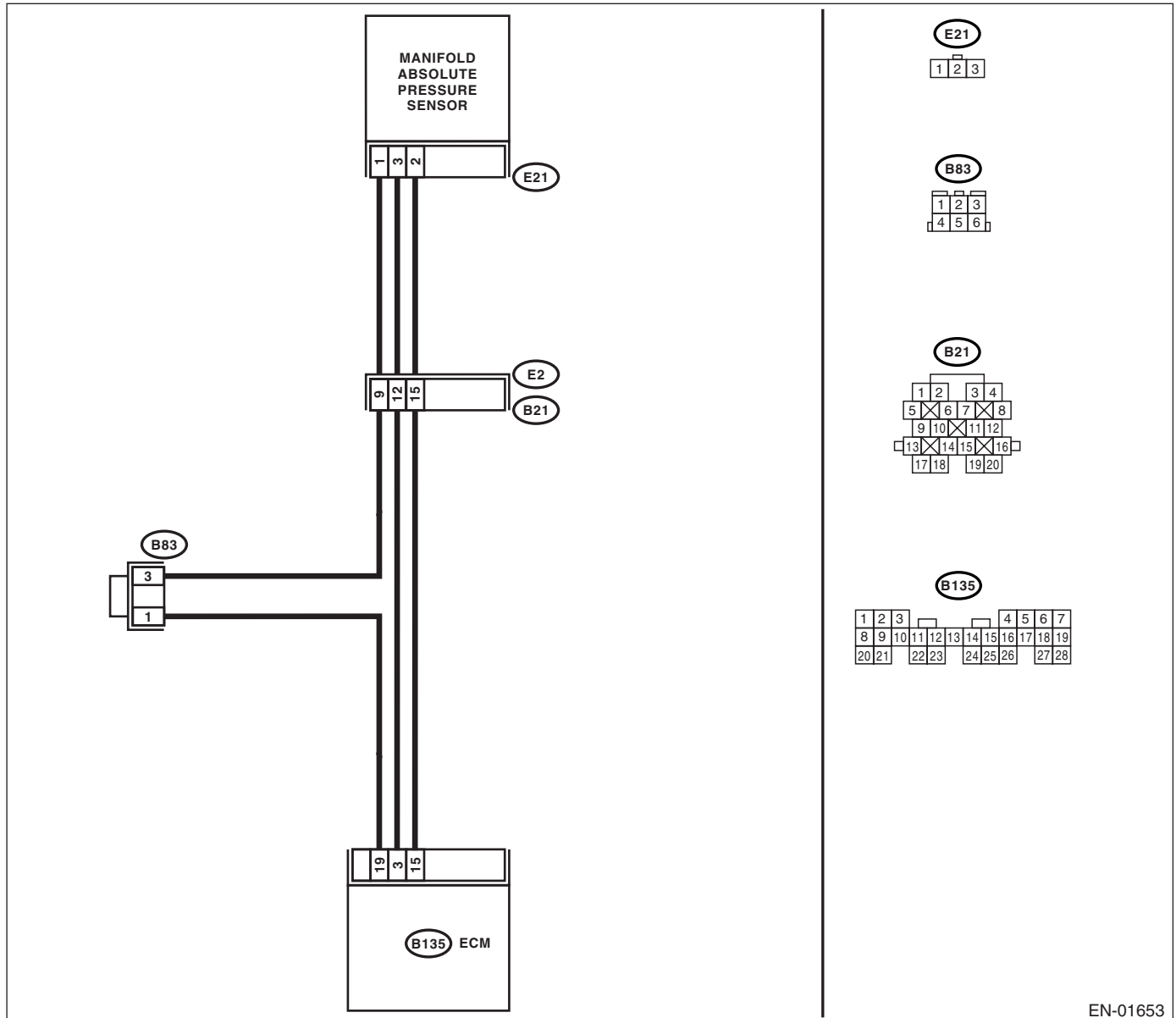

EN-01653

Diagnostic Procedure with Diagnostic Trouble Code (DTC)

ENGINE (DIAGNOSTICS)

Step	Check	Yes	No	
1	CHECK FOR OTHER DTC ON DISPLAY.	Is any other DTC displayed?	Inspect DTC using "List of Diagnostic Trouble Code (DTC)". <Ref. to EN(H4SO)(diag)-71, List of Diagnostic Trouble Code (DTC).>	Go to step 2.
2	CHECK AIR INTAKE SYSTEM.	Are there holes, loose bolts or disconnection of hose on air intake system?	Repair air intake system.	Go to step 3.
3	CHECK PRESSURE SENSOR. 1) Start the engine and warm-up engine until coolant temperature is greater than 60°C (140°F). 2) Place the selector lever or shift lever in "P" or "N" position. 3) Turn the A/C switch to OFF. 4) All accessory switches OFF. 5) Read the data of intake manifold pressure sensor signal using Subaru Select Monitor or OBD-II general scan tool. NOTE: • Subaru Select Monitor For detailed operation procedures, refer to "READ CURRENT DATA FOR ENGINE". <Ref. to EN(H4SO)(diag)-30, Subaru Select Monitor.> • OBD-II general scan tool For detailed operation procedures, refer to the OBD-II General Scan Tool Instruction Manual.	Ignition ON: Is the measured value 73.3 — 106.6 kPa (550 — 800 mmHg, 21.65 — 31.50 inHg)? Idling: Is the measured value 20.0 — 46.7 kPa (150 — 350 mmHg, 5.91 — 13.78 inHg)?	Go to step 4.	Replace the manifold absolute pressure sensor. <Ref. to FU(H4SO)-30, Manifold Absolute Pressure Sensor.>
4	CHECK THROTTLE POSITION. Read the data of throttle position signal using Subaru Select Monitor or OBD-II general scan tool. NOTE: • Subaru Select Monitor For detailed operation procedures, refer to "READ CURRENT DATA FOR ENGINE". <Ref. to EN(H4SO)(diag)-30, Subaru Select Monitor.> • OBD-II general scan tool For detailed operation procedures, refer to the OBD-II General Scan Tool Instruction Manual.	Is the measured value less than 5% when throttle is fully closed?	Go to step 5.	Adjust or replace the throttle position sensor. <Ref. to FU(H4SO)-28, Throttle Position Sensor.>
5	CHECK THROTTLE POSITION.	Is the measured value more than 85% when throttle is wide open?	Replace the manifold absolute pressure sensor. <Ref. to FU(H4SO)-30, Manifold Absolute Pressure Sensor.>	Replace the throttle position sensor. <Ref. to FU(H4SO)-28, Throttle Position Sensor.>

Diagnostic Procedure with Diagnostic Trouble Code (DTC)

ENGINE (DIAGNOSTICS)

J: DTC P0107 MANIFOLD ABSOLUTE PRESSURE/BAROMETRIC PRESSURE CIRCUIT LOW INPUT

DTC DETECTING CONDITION:

- Immediately at fault recognition
- GENERAL DESCRIPTION <Ref. to GD(H4SO)-27, DTC P0107 MANIFOLD ABSOLUTE PRESSURE/BAROMETRIC PRESSURE CIRCUIT LOW INPUT, Diagnostic Trouble Code (DTC) Detecting Criteria.>

CAUTION:

After repair or replacement of faulty parts, conduct Clear Memory Mode <Ref. to EN(H4SO)(diag)-44, OPERATION, Clear Memory Mode.> and Inspection Mode <Ref. to EN(H4SO)(diag)-37, OPERATION, Inspection Mode.>.

WIRING DIAGRAM:

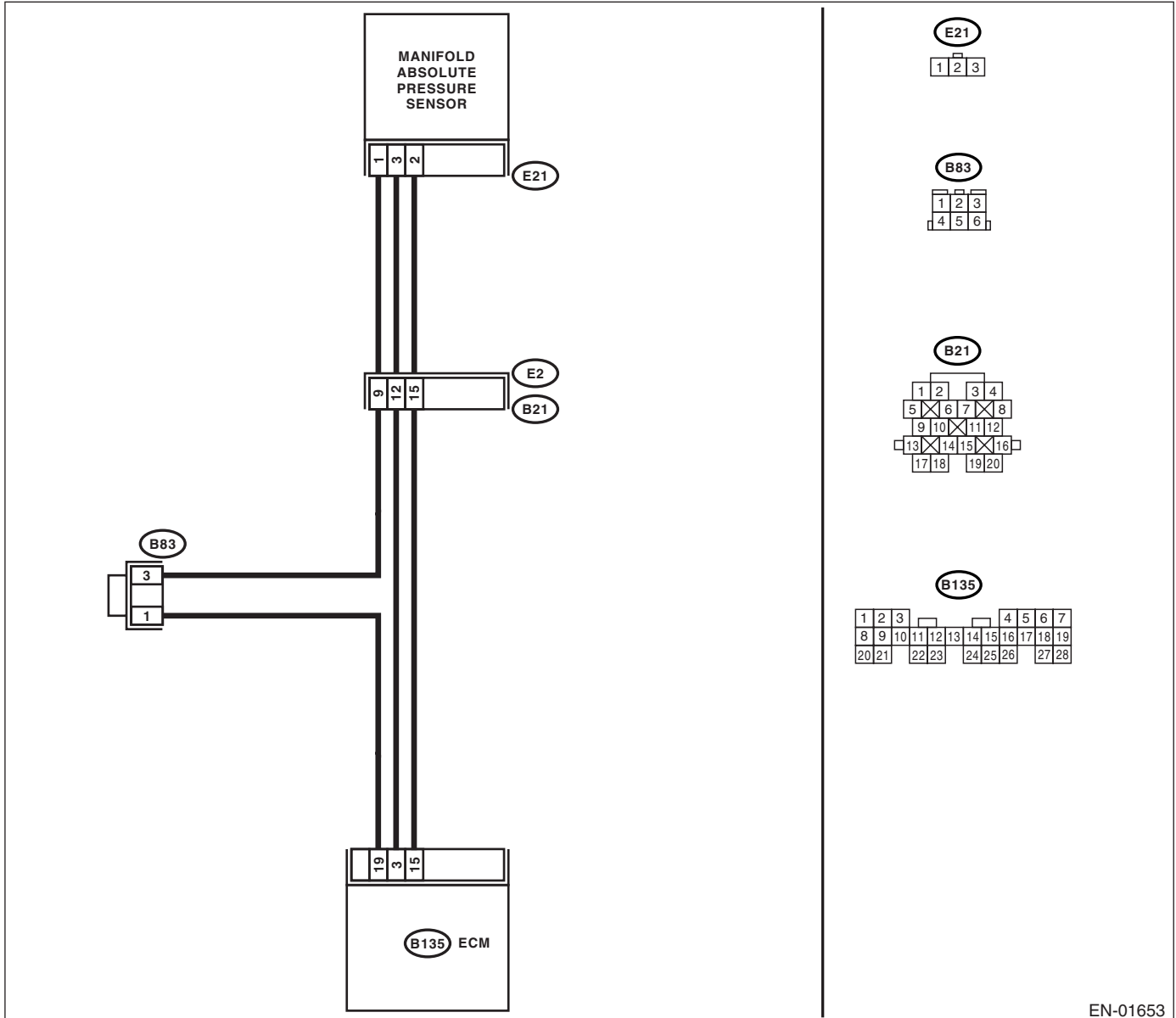

EN-01653

Diagnostic Procedure with Diagnostic Trouble Code (DTC)

ENGINE (DIAGNOSTICS)

Step	Check	Yes	No
1 CHECK CURRENT DATA. 1) Start the engine. 2) Read the data of intake manifold absolute pressure signal using Subaru Select Monitor or OBD-II general scan tool. NOTE: • Subaru Select Monitor For detailed operation procedure, refer to the "READ CURRENT DATA FOR ENGINE". <Ref. to EN(H4SO)(diag)-30, Subaru Select Monitor.> • OBD-II general scan tool For detailed operation procedures, refer to the OBD-II General Scan Tool Instruction Manual.	Is the measured value less than 13.3 kPa (100 mmHg, 3.94 inHg)?	Go to step 3.	Go to step 2.
2 CHECK POOR CONTACT. Check poor contact in ECM and manifold absolute pressure sensor connector.	Is there poor contact in ECM or manifold absolute pressure sensor connector?	Repair poor contact in ECM or manifold absolute pressure sensor connector.	Even if malfunction indicator light lights up, the circuit has returned to a normal condition at this time.
3 CHECK OUTPUT SIGNAL FOR ECM. Measure the voltage between ECM connector and chassis ground. <i>Connector & terminal</i> <i>(B135) No. 3 (+) — Chassis ground (-):</i>	Is the voltage more than 4.5 V?	Go to step 5.	Go to step 4.
4 CHECK OUTPUT SIGNAL FOR ECM. Measure the voltage between ECM connector and chassis ground. <i>Connector & terminal</i> <i>(B135) No. 3 (+) — Chassis ground (-):</i>	Does the voltage change by shaking the ECM harness and connector?	Repair poor contact in ECM connector.	Contact SOA Service Center. NOTE: Inspection by DTM is required, because probable cause is deterioration of multiple parts.
5 CHECK INPUT SIGNAL FOR ECM. Measure the voltage between ECM and chassis ground. <i>Connector & terminal</i> <i>(B135) No. 15 (+) — Chassis ground (-):</i>	Is the voltage less than 0.2 V?	Go to step 7.	Go to step 6.
6 CHECK INPUT SIGNAL FOR ECM. (USING SUBARU SELECT MONITOR) Read the data of atmospheric absolute pressure signal using Subaru Select Monitor. NOTE: • Subaru Select Monitor For detailed operation procedure, refer to the "READ CURRENT DATA FOR ENGINE". <Ref. to EN(H4SO)(diag)-30, Subaru Select Monitor.>	Is the measured value more than 13.3 kPa (100 mmHg, 3.94 inHg) by shaking the harness and connector of ECM?	Repair poor contact in ECM connector.	Go to step 7.

Diagnostic Procedure with Diagnostic Trouble Code (DTC)

ENGINE (DIAGNOSTICS)

Step	Check	Yes	No
7 CHECK HARNESS BETWEEN MANIFOLD ABSOLUTE PRESSURE SENSOR AND ECM CONNECTOR. 1) Turn the ignition switch to OFF. 2) Disconnect the connector from manifold absolute pressure sensor. 3) Turn the ignition switch to ON. 4) Measure the voltage between manifold absolute pressure sensor connector and engine ground. <i>Connector & terminal</i> <i>(E21) No. 3 (+) — Engine ground (-):</i>	Is the voltage more than 4.5 V?	Go to step 8.	Repair open circuit in harness between ECM and manifold absolute pressure sensor connector.
8 CHECK HARNESS BETWEEN MANIFOLD ABSOLUTE PRESSURE SENSOR AND ECM CONNECTOR. 1) Turn the ignition switch to OFF. 2) Disconnect the connector from ECM. 3) Measure the resistance of harness between ECM and manifold absolute pressure sensor connector. <i>Connector & terminal</i> <i>(B135) No. 19 — (E21) No. 1:</i>	Is the resistance less than 1 Ω ?	Go to step 9.	Repair open circuit in harness between ECM and manifold absolute pressure sensor connector.
9 CHECK POOR CONTACT. Check poor contact in manifold absolute pressure sensor connector.	Is there poor contact in manifold absolute pressure sensor connector?	Repair poor contact in manifold absolute pressure sensor connector.	Replace the manifold absolute pressure sensor. <Ref. to FU(H4SO)-30, Manifold Absolute Pressure Sensor.>

Diagnostic Procedure with Diagnostic Trouble Code (DTC)

ENGINE (DIAGNOSTICS)

K: DTC P0108 MANIFOLD ABSOLUTE PRESSURE/BAROMETRIC PRESSURE CIRCUIT HIGH INPUT

DTC DETECTING CONDITION:

- Immediately at fault recognition
- GENERAL DESCRIPTION <Ref. to GD(H4SO)-29, DTC P0108 MANIFOLD ABSOLUTE PRESSURE/BAROMETRIC PRESSURE CIRCUIT HIGH INPUT, Diagnostic Trouble Code (DTC) Detecting Criteria.>

CAUTION:

After repair or replacement of faulty parts, conduct Clear Memory Mode <Ref. to EN(H4SO)(diag)-44, OPERATION, Clear Memory Mode.> and Inspection Mode <Ref. to EN(H4SO)(diag)-37, OPERATION, Inspection Mode.>.

WIRING DIAGRAM:

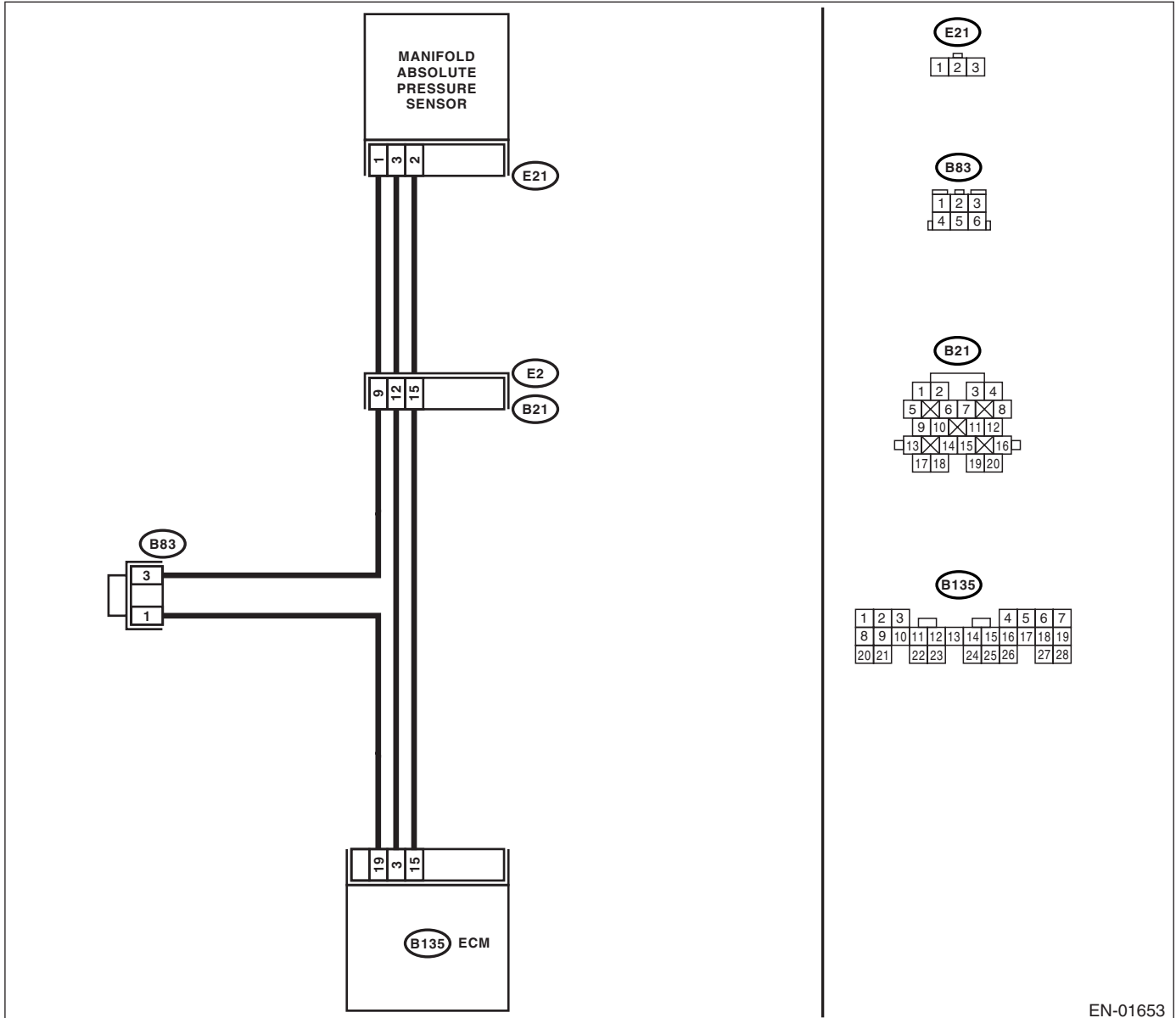

EN-01653

Diagnostic Procedure with Diagnostic Trouble Code (DTC)

ENGINE (DIAGNOSTICS)

Step	Check	Yes	No
1 CHECK CURRENT DATA. 1) Start the engine. 2) Read the data of intake manifold absolute pressure signal using Subaru Select Monitor or OBD-II general scan tool. NOTE: • Subaru Select Monitor For detailed operation procedure, refer to the "READ CURRENT DATA FOR ENGINE". <Ref. to EN(H4SO)(diag)-30, Subaru Select Monitor.> • OBD-II general scan tool For detailed operation procedures, refer to the OBD-II General Scan Tool Instruction Manual.	Is the measured value more than 119.5 kPa (896.5 mmHg, 35.29 inHg)?	Go to step 10.	Go to step 2.
2 CHECK OUTPUT SIGNAL FOR ECM. Measure the voltage between ECM connector and chassis ground. Connector & terminal (B135) No. 3 (+) — Chassis ground (-):	Is the voltage more than 4.5 V?	Go to step 4.	Go to step 3.
3 CHECK OUTPUT SIGNAL FOR ECM. Measure the voltage between ECM connector and chassis ground. Connector & terminal (B135) No. 3 (+) — Chassis ground (-):	Does the voltage change by shaking the ECM harness and connector?	Repair poor contact in ECM connector.	Contact SOA Service Center. NOTE: Inspection by DTM is required, because probable cause is deterioration of multiple parts.
4 CHECK INPUT SIGNAL FOR ECM. Measure the voltage between ECM connector and chassis ground. Connector & terminal (B135) No. 15 (+) — Chassis ground (-):	Is the voltage less than 0.2 V?	Go to step 6.	Go to step 5.
5 CHECK INPUT SIGNAL FOR ECM. (USING SUBARU SELECT MONITOR) Read the data of atmospheric absolute pressure signal using Subaru Select Monitor. NOTE: • Subaru Select Monitor For detailed operation procedure, refer to the "READ CURRENT DATA FOR ENGINE". <Ref. to EN(H4SO)(diag)-30, Subaru Select Monitor.>	Is the measured value more than 13.3 kPa (100 mmHg, 3.94 inHg) by shaking the harness and connector of ECM?	Repair poor contact in ECM connector.	Go to step 6.
6 CHECK HARNESS BETWEEN MANIFOLD ABSOLUTE PRESSURE SENSOR AND ECM CONNECTOR. 1) Turn the ignition switch to OFF. 2) Disconnect the connector from manifold absolute pressure sensor. 3) Turn the ignition switch to ON. 4) Measure the voltage between manifold absolute pressure sensor connector and engine ground. Connector & terminal (E21) No. 3 (+) — Engine ground (-):	Is the voltage more than 4.5 V?	Go to step 7.	Repair open circuit in harness between ECM and manifold absolute pressure sensor connector.

Diagnostic Procedure with Diagnostic Trouble Code (DTC)

ENGINE (DIAGNOSTICS)

Step	Check	Yes	No
<p>7</p> <p>CHECK HARNESS BETWEEN MANIFOLD ABSOLUTE PRESSURE SENSOR AND ECM CONNECTOR.</p> <p>1) Turn the ignition switch to OFF. 2) Disconnect the connector from ECM. 3) Measure the resistance of harness between ECM and manifold absolute pressure sensor connector.</p> <p>Connector & terminal (B135) No. 15 — (E21) No. 2:</p>	<p>Is the resistance less than 1 Ω?</p>	<p>Go to step 8.</p>	<p>Repair open circuit in harness between ECM and manifold absolute pressure sensor connector.</p>
<p>8</p> <p>CHECK HARNESS BETWEEN MANIFOLD ABSOLUTE PRESSURE SENSOR AND ECM CONNECTOR.</p> <p>Measure the resistance of harness between ECM and manifold absolute pressure sensor connector.</p> <p>Connector & terminal (B135) No. 19 — (E21) No. 1:</p>	<p>Is the resistance less than 1 Ω?</p>	<p>Go to step 9.</p>	<p>Repair open circuit in harness between ECM and manifold absolute pressure sensor connector.</p>
<p>9</p> <p>CHECK POOR CONTACT.</p> <p>Check poor contact in manifold absolute pressure sensor connector.</p>	<p>Is there poor contact in manifold absolute pressure sensor connector?</p>	<p>Repair poor contact in manifold absolute pressure sensor connector.</p>	<p>Replace the manifold absolute pressure sensor. <Ref. to FU(H4SO)-30, Manifold Absolute Pressure Sensor.></p>
<p>10</p> <p>CHECK HARNESS BETWEEN MANIFOLD ABSOLUTE PRESSURE SENSOR AND ECM CONNECTOR.</p> <p>1) Turn the ignition switch to OFF and Subaru Select Monitor or the OBD-II general scan tool switch to OFF. 2) Disconnect the connector from manifold absolute pressure sensor. 3) Turn the ignition switch to ON and Subaru Select Monitor or the OBD-II general scan tool switch to ON. 4) Read the data of intake manifold absolute pressure signal using Subaru Select Monitor or OBD-II general scan tool.</p> <p>NOTE:</p> <ul style="list-style-type: none"> • Subaru Select Monitor <p>For detailed operation procedure, refer to the "READ CURRENT DATA FOR ENGINE". <Ref. to EN(H4SO)(diag)-30, Subaru Select Monitor.></p> <ul style="list-style-type: none"> • OBD-II general scan tool <p>For detailed operation procedures, refer to the OBD-II General Scan Tool Instruction Manual.</p>	<p>Is the measured value more than 119.5 kPa (896.5 mmHg, 35.29 inHg)?</p>	<p>Repair battery short circuit in harness between ECM and manifold absolute pressure sensor connector.</p>	<p>Replace the manifold absolute pressure sensor. <Ref. to FU(H4SO)-30, Manifold Absolute Pressure Sensor.></p>

Diagnostic Procedure with Diagnostic Trouble Code (DTC)

ENGINE (DIAGNOSTICS)

L: DTC P0111 INTAKE AIR TEMPERATURE CIRCUIT RANGE/PERFORMANCE

DTC DETECTING CONDITION:

- Two consecutive driving cycles with fault
- GENERAL DESCRIPTION <Ref. to GD(H4SO)-31, DTC P0111 INTAKE AIR TEMPERATURE CIRCUIT RANGE/PERFORMANCE, Diagnostic Trouble Code (DTC) Detecting Criteria.>

TROUBLE SYMPTOM:

- Erroneous idling
- Poor driving performance

CAUTION:

After repair or replacement of faulty parts, conduct Clear Memory Mode <Ref. to EN(H4SO)(diag)-44, OPERATION, Clear Memory Mode.> and Inspection Mode <Ref. to EN(H4SO)(diag)-37, OPERATION, Inspection Mode.>.

WIRING DIAGRAM:

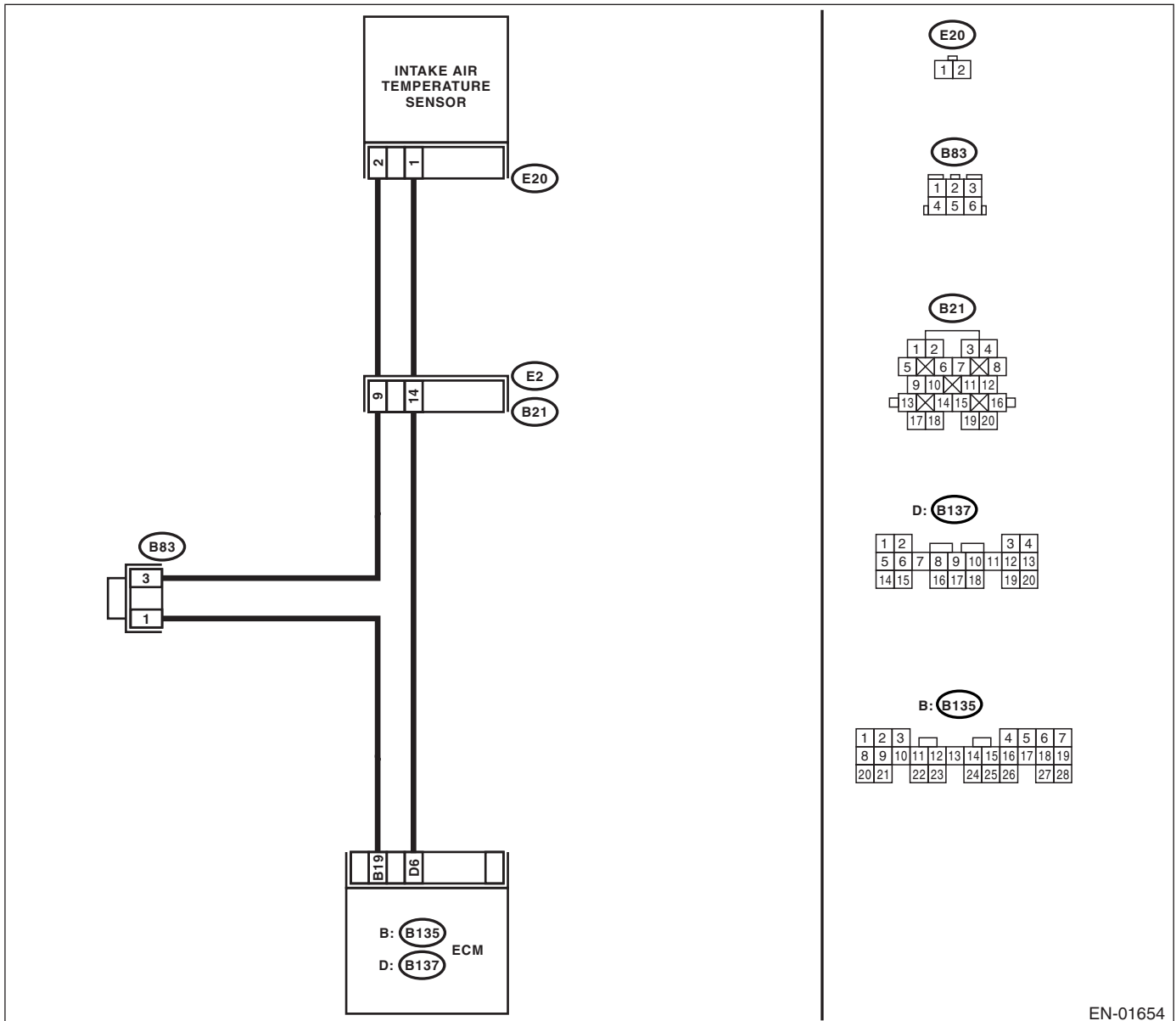

Diagnostic Procedure with Diagnostic Trouble Code (DTC)

ENGINE (DIAGNOSTICS)

Step	Check	Yes	No
1 CHECK ANY OTHER DTC ON DISPLAY.	Is any other DTC displayed?	Inspect DTC using "List of Diagnostic Trouble Code (DTC)". <Ref. to EN(H4SO)(diag)-71, List of Diagnostic Trouble Code (DTC).> NOTE: In this case, it is not necessary to inspect DTC P0111.	Replace the intake air temperature sensor. <Ref. to FU(H4SO)-31, Intake Air Temperature Sensor.>

Diagnostic Procedure with Diagnostic Trouble Code (DTC)

ENGINE (DIAGNOSTICS)

M: DTC P0112 INTAKE AIR TEMPERATURE CIRCUIT LOW INPUT

DTC DETECTING CONDITION:

- Immediately at fault recognition
- GENERAL DESCRIPTION <Ref. to GD(H4SO)-33, DTC P0112 INTAKE AIR TEMPERATURE CIRCUIT LOW INPUT, Diagnostic Trouble Code (DTC) Detecting Criteria.>

TROUBLE SYMPTOM:

- Erroneous idling
- Poor driving performance

CAUTION:

After repair or replacement of faulty parts, conduct Clear Memory Mode <Ref. to EN(H4SO)(diag)-44, OPERATION, Clear Memory Mode.> and Inspection Mode <Ref. to EN(H4SO)(diag)-37, OPERATION, Inspection Mode.>.

WIRING DIAGRAM:

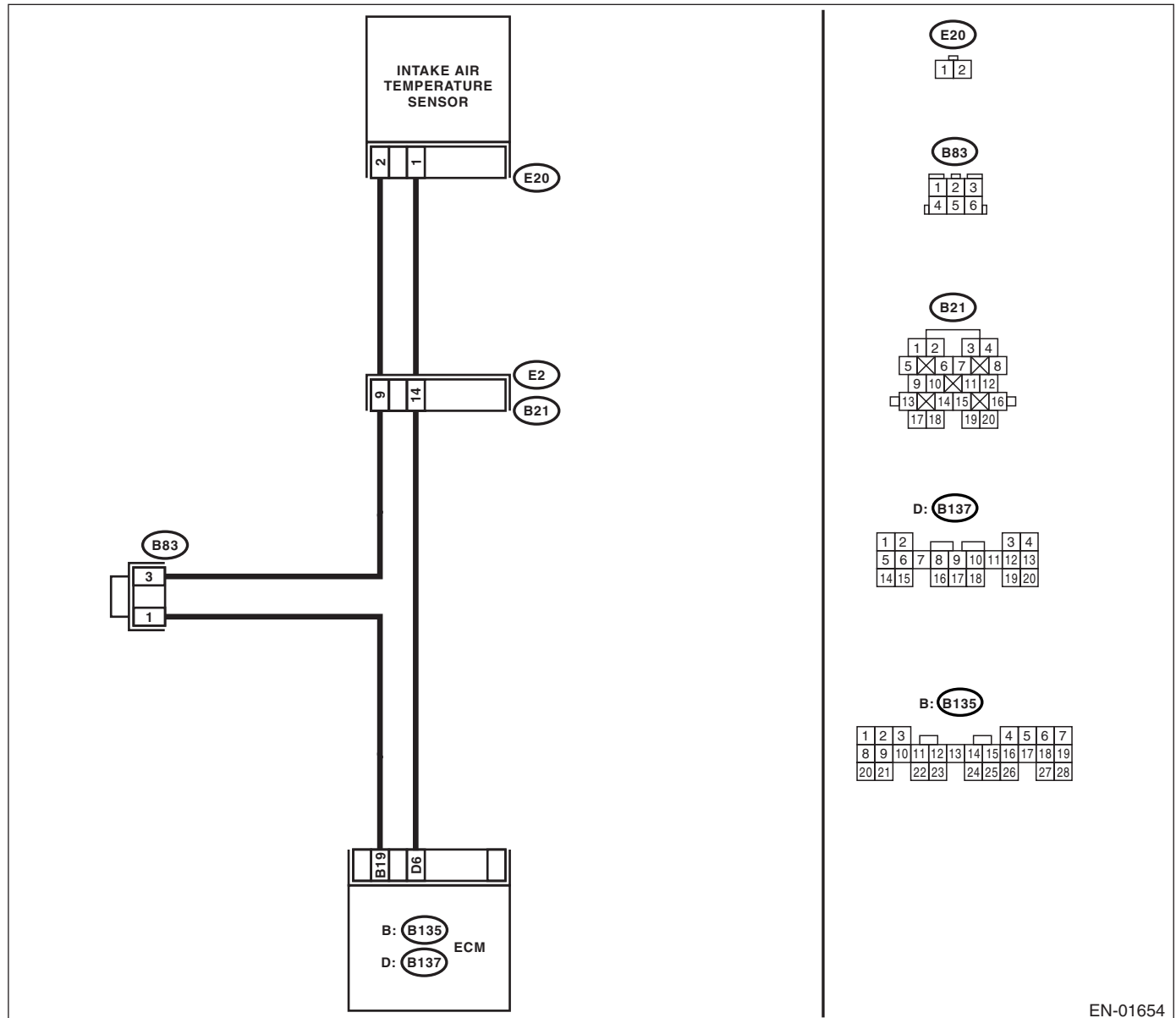

EN-01654

Diagnostic Procedure with Diagnostic Trouble Code (DTC)

ENGINE (DIAGNOSTICS)

Step	Check	Yes	No
<p>1</p> <p>CHECK CURRENT DATA.</p> <p>1) Start the engine.</p> <p>2) Read the data of intake air temperature sensor signal using Subaru Select Monitor or the OBD-II general scan tool.</p> <p>NOTE:</p> <ul style="list-style-type: none"> • Subaru Select Monitor <p>For detailed operation procedure, refer to the "READ CURRENT DATA FOR ENGINE". <Ref. to EN(H4SO)(diag)-30, Subaru Select Monitor.></p> <ul style="list-style-type: none"> • OBD-II general scan tool <p>For detailed operation procedure, refer to the OBD-II General Scan Tool Instruction Manual.</p>	<p>Is the intake air temperature more than 120°C (248°F)?</p>	<p>Go to step 2.</p>	<p>Repair poor contact.</p> <p>NOTE:</p> <p>In this case, repair the following:</p> <ul style="list-style-type: none"> • Poor contact in intake air temperature sensor • Poor contact in ECM • Poor contact in coupling connector • Poor contact in joint connector
<p>2</p> <p>CHECK HARNESS BETWEEN INTAKE AIR TEMPERATURE SENSOR AND ECM CONNECTOR.</p> <p>1) Turn the ignition switch to OFF.</p> <p>2) Disconnect the connector from intake air temperature sensor.</p> <p>3) Turn the ignition switch to ON.</p> <p>4) Read the data of intake air temperature sensor signal using Subaru Select Monitor or the OBD-II general scan tool.</p> <p>NOTE:</p> <ul style="list-style-type: none"> • Subaru Select Monitor <p>For detailed operation procedure, refer to the "READ CURRENT DATA FOR ENGINE". <Ref. to EN(H4SO)(diag)-30, Subaru Select Monitor.></p> <ul style="list-style-type: none"> • OBD-II general scan tool <p>For detailed operation procedure, refer to the OBD-II General Scan Tool Instruction Manual.</p>	<p>Is the intake air temperature less than -40°C (-40°F)?</p>	<p>Replace the intake air temperature sensor. <Ref. to FU(H4SO)-31, Intake Air Temperature Sensor.></p>	<p>Repair ground short circuit in harness between intake air temperature sensor and ECM connector.</p>

Diagnostic Procedure with Diagnostic Trouble Code (DTC)

ENGINE (DIAGNOSTICS)

N: DTC P0113 INTAKE AIR TEMPERATURE CIRCUIT HIGH INPUT

DTC DETECTING CONDITION:

- Immediately at fault recognition
- GENERAL DESCRIPTION <Ref. to GD(H4SO)-35, DTC P0113 INTAKE AIR TEMPERATURE CIRCUIT HIGH INPUT, Diagnostic Trouble Code (DTC) Detecting Criteria.>

TROUBLE SYMPTOM:

- Erroneous idling
- Poor driving performance

CAUTION:

After repair or replacement of faulty parts, conduct Clear Memory Mode <Ref. to EN(H4SO)(diag)-44, OPERATION, Clear Memory Mode.> and Inspection Mode <Ref. to EN(H4SO)(diag)-37, OPERATION, Inspection Mode.>.

WIRING DIAGRAM:

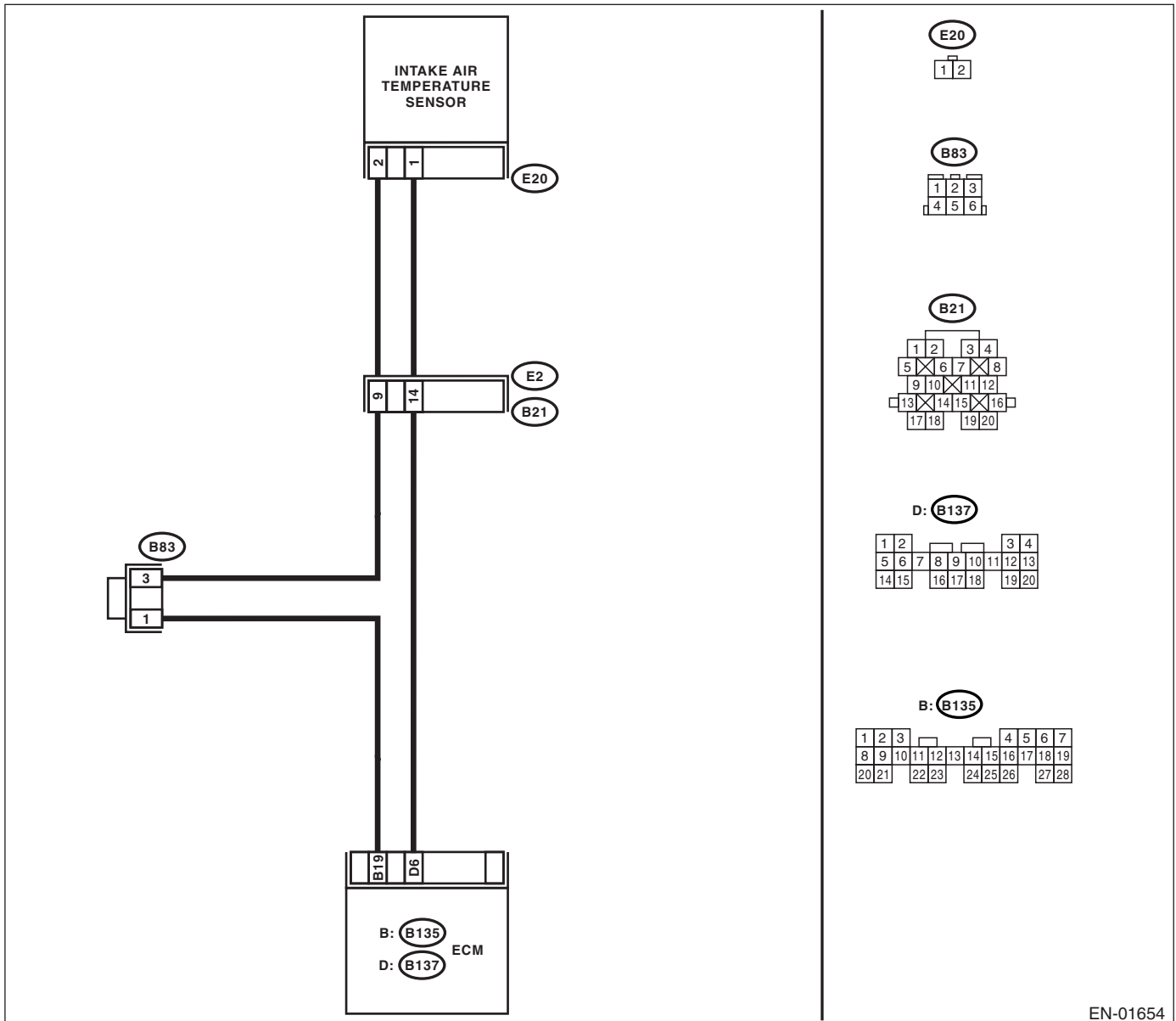

EN-01654

Diagnostic Procedure with Diagnostic Trouble Code (DTC)

ENGINE (DIAGNOSTICS)

Step	Check	Yes	No
<p>1</p> <p>CHECK CURRENT DATA.</p> <p>1) Start the engine.</p> <p>2) Read the data of intake air temperature sensor signal using Subaru Select Monitor or the OBD-II general scan tool.</p> <p>NOTE:</p> <ul style="list-style-type: none"> Subaru Select Monitor <p>For detailed operation procedure, refer to the "READ CURRENT DATA FOR ENGINE". <Ref. to EN(H4SO)(diag)-30, Subaru Select Monitor.></p> <ul style="list-style-type: none"> OBD-II general scan tool <p>For detailed operation procedure, refer to the OBD-II General Scan Tool Instruction Manual.</p>	<p>Is the intake air temperature less than -40°C (-40°F)?</p>	<p>Go to step 2.</p>	<p>Repair poor contact.</p> <p>NOTE:</p> <p>In this case, repair the following:</p> <ul style="list-style-type: none"> Poor contact in intake air temperature sensor Poor contact in ECM Poor contact in coupling connector Poor contact in joint connector
<p>2</p> <p>CHECK HARNESS BETWEEN INTAKE AIR TEMPERATURE SENSOR AND ECM CONNECTOR.</p> <p>1) Turn the ignition switch to OFF.</p> <p>2) Disconnect the connector from intake air temperature sensor.</p> <p>3) Measure the voltage between intake air temperature and manifold absolute pressure sensor connector and engine ground.</p> <p>Connector & terminal (E20) No. 1 (+) — Engine ground (-):</p>	<p>Is the voltage more than 10 V?</p>	<p>Repair battery short circuit in harness between intake air temperature sensor and ECM connector.</p>	<p>Go to step 3.</p>
<p>3</p> <p>CHECK HARNESS BETWEEN INTAKE AIR TEMPERATURE SENSOR AND ECM CONNECTOR.</p> <p>1) Turn the ignition switch to ON.</p> <p>2) Measure the voltage between intake air temperature sensor connector and engine ground.</p> <p>Connector & terminal (E20) No. 1 (+) — Engine ground (-):</p>	<p>Is the voltage more than 10 V?</p>	<p>Repair battery short circuit in harness between intake air temperature sensor and ECM connector.</p>	<p>Go to step 4.</p>
<p>4</p> <p>CHECK HARNESS BETWEEN INTAKE AIR TEMPERATURE SENSOR AND ECM CONNECTOR.</p> <p>Measure the voltage between intake air temperature sensor connector and engine ground.</p> <p>Connector & terminal (E20) No. 1 (+) — Engine ground (-):</p>	<p>Is the voltage more than 3 V?</p>	<p>Go to step 5.</p>	<p>Repair harness and connector.</p> <p>NOTE:</p> <p>In this case, repair the following:</p> <ul style="list-style-type: none"> Open circuit in harness between intake air temperature sensor and ECM connector Poor contact in intake air temperature sensor Poor contact in ECM Poor contact in coupling connector Poor contact in joint connector

Diagnostic Procedure with Diagnostic Trouble Code (DTC)

ENGINE (DIAGNOSTICS)

Step	Check	Yes	No
<p>5</p> <p>CHECK HARNESS BETWEEN INTAKE AIR TEMPERATURE SENSOR AND ECM CONNECTOR.</p> <p>1) Turn the ignition switch to OFF.</p> <p>2) Measure the resistance of harness between intake air temperature sensor connector and engine ground.</p> <p>Connector & terminal (E20) No. 2 — Engine ground:</p>	<p>Is the resistance less than 5 Ω?</p>	<p>Replace the intake air temperature sensor. <Ref. to FU(H4SO)-31, Intake Air Temperature Sensor.></p>	<p>Repair harness and connector.</p> <p>NOTE: In this case, repair the following:</p> <ul style="list-style-type: none"> • Open circuit in harness between intake air temperature sensor and ECM connector • Poor contact in intake air temperature sensor • Poor contact in ECM • Poor contact in coupling connector • Poor contact in joint connector

Diagnostic Procedure with Diagnostic Trouble Code (DTC)

ENGINE (DIAGNOSTICS)

O: DTC P0117 ENGINE COOLANT TEMPERATURE CIRCUIT LOW INPUT

DTC DETECTING CONDITION:

- Immediately at fault recognition
- GENERAL DESCRIPTION <Ref. to GD(H4SO)-37, DTC P0117 ENGINE COOLANT TEMPERATURE CIRCUIT LOW INPUT, Diagnostic Trouble Code (DTC) Detecting Criteria.>

TROUBLE SYMPTOM:

- Hard to start
- Erroneous idling
- Poor driving performance

CAUTION:

After repair or replacement of faulty parts, conduct Clear Memory Mode <Ref. to EN(H4SO)(diag)-44, OPERATION, Clear Memory Mode.> and Inspection Mode <Ref. to EN(H4SO)(diag)-37, OPERATION, Inspection Mode.>.

WIRING DIAGRAM:

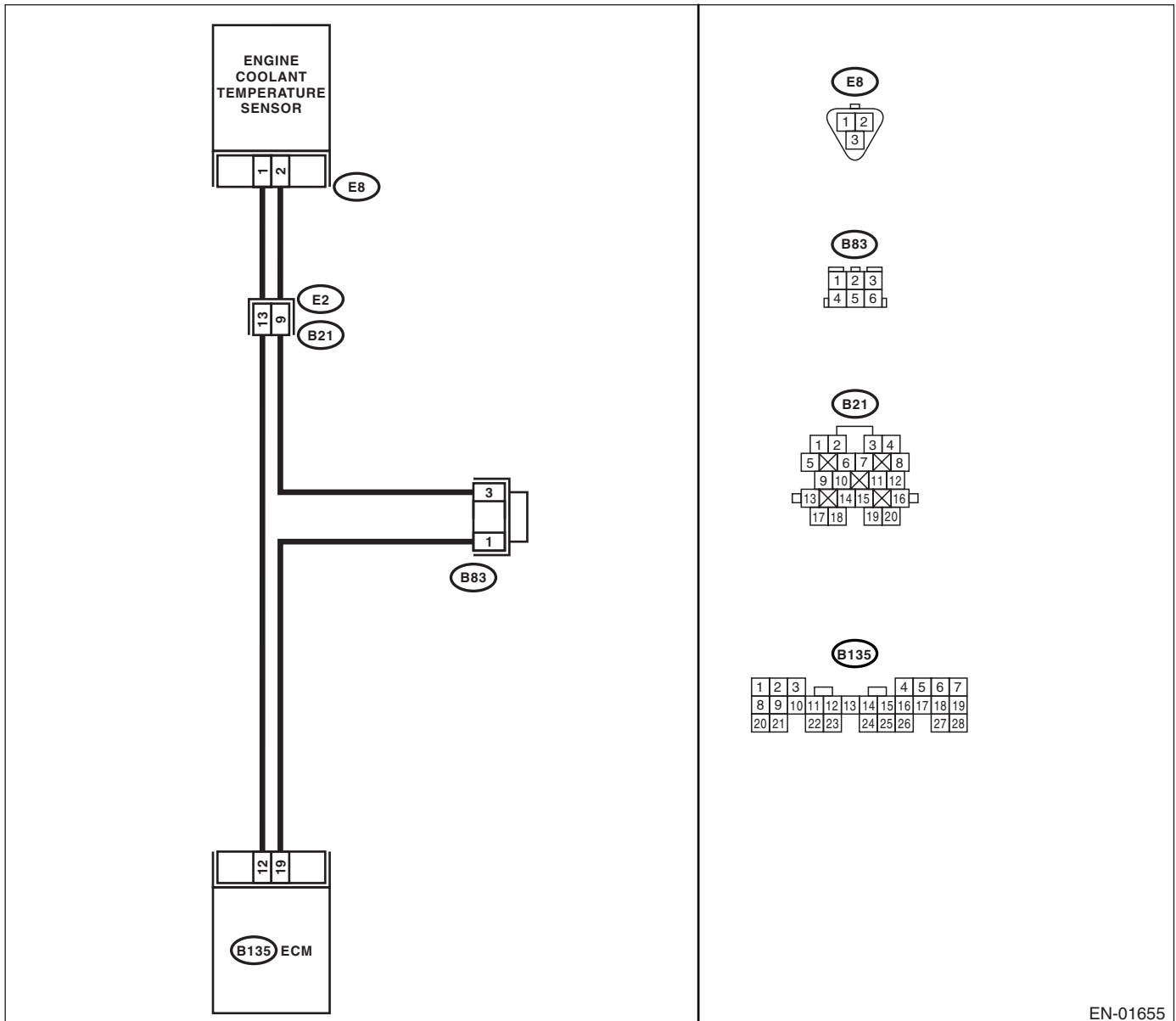

EN-01655

Diagnostic Procedure with Diagnostic Trouble Code (DTC)

ENGINE (DIAGNOSTICS)

Step	Check	Yes	No
<p>1</p> <p>CHECK CURRENT DATA.</p> <p>1) Start the engine.</p> <p>2) Read the data of engine coolant temperature sensor signal using Subaru Select Monitor or OBD-II general scan tool.</p> <p>NOTE:</p> <ul style="list-style-type: none"> • Subaru Select Monitor <p>For detailed operation procedure, refer to the "READ CURRENT DATA FOR ENGINE". <Ref. to EN(H4SO)(diag)-30, Subaru Select Monitor.></p> <ul style="list-style-type: none"> • OBD-II general scan tool <p>For detailed operation procedures, refer to the OBD-II General Scan Tool Instruction Manual.</p>	<p>Is the engine coolant temperature more than 150°C (302°F)?</p>	<p>Go to step 2.</p>	<p>Repair poor contact.</p> <p>NOTE:</p> <p>In this case, repair the following:</p> <ul style="list-style-type: none"> • Poor contact in engine coolant temperature sensor • Poor contact in ECM • Poor contact in coupling connector • Poor contact in joint connector
<p>2</p> <p>CHECK HARNESS BETWEEN ENGINE COOLANT TEMPERATURE SENSOR AND ECM CONNECTOR.</p> <p>1) Turn the ignition switch to OFF.</p> <p>2) Disconnect the connector from engine coolant temperature sensor.</p> <p>3) Turn the ignition switch to ON.</p> <p>4) Read the data of engine coolant temperature sensor signal using Subaru Select Monitor or OBD-II general scan tool.</p> <p>NOTE:</p> <ul style="list-style-type: none"> • Subaru Select Monitor <p>For detailed operation procedure, refer to the "READ CURRENT DATA FOR ENGINE". <Ref. to EN(H4SO)(diag)-30, Subaru Select Monitor.></p> <ul style="list-style-type: none"> • OBD-II general scan tool <p>For detailed operation procedures, refer to the OBD-II General Scan Tool Instruction Manual.</p>	<p>Is the engine coolant temperature less than -40°C (-40°F)?</p>	<p>Replace the engine coolant temperature sensor. <Ref. to FU(H4SO)-24, Engine Coolant Temperature Sensor.></p>	<p>Repair ground short circuit in harness between engine coolant temperature sensor and ECM connector.</p>

Diagnostic Procedure with Diagnostic Trouble Code (DTC)

ENGINE (DIAGNOSTICS)

P: DTC P0118 ENGINE COOLANT TEMPERATURE CIRCUIT HIGH INPUT

DTC DETECTING CONDITION:

- Immediately at fault recognition
- GENERAL DESCRIPTION <Ref. to GD(H4SO)-39, DTC P0118 ENGINE COOLANT TEMPERATURE CIRCUIT HIGH INPUT, Diagnostic Trouble Code (DTC) Detecting Criteria.>

TROUBLE SYMPTOM:

- Hard to start
- Erroneous idling
- Poor driving performance

CAUTION:

After repair or replacement of faulty parts, conduct Clear Memory Mode <Ref. to EN(H4SO)(diag)-44, OPERATION, Clear Memory Mode.> and Inspection Mode <Ref. to EN(H4SO)(diag)-37, OPERATION, Inspection Mode.>.

WIRING DIAGRAM:

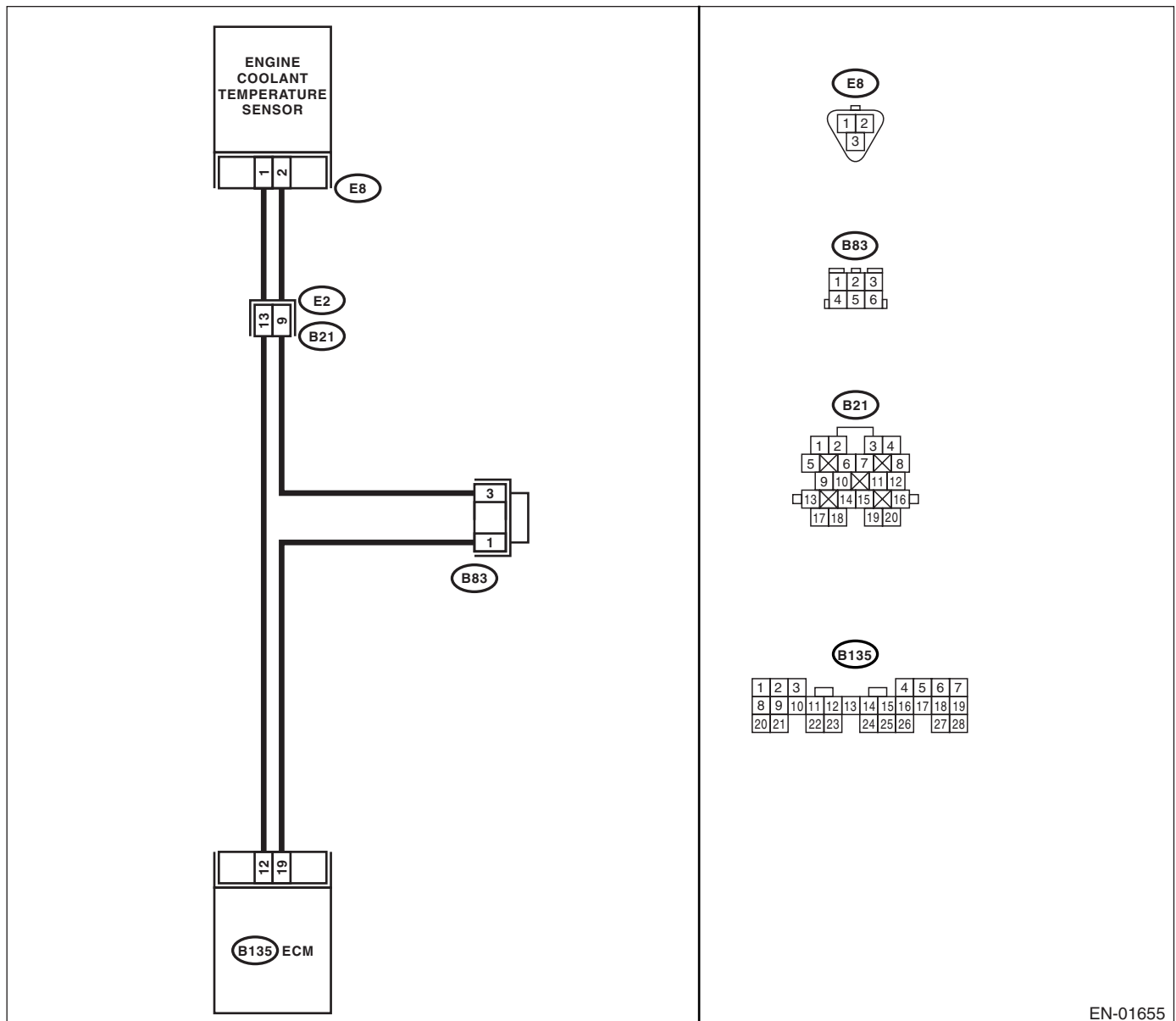

EN-01655

Diagnostic Procedure with Diagnostic Trouble Code (DTC)

ENGINE (DIAGNOSTICS)

Step	Check	Yes	No
<p>1 CHECK CURRENT DATA.</p> <p>1) Start the engine.</p> <p>2) Read the data of engine coolant temperature sensor signal using Subaru Select Monitor or OBD-II general scan tool.</p> <p>NOTE:</p> <ul style="list-style-type: none"> • Subaru Select Monitor <p>For detailed operation procedure, refer to the "READ CURRENT DATA FOR ENGINE". <Ref. to EN(H4SO)(diag)-30, Subaru Select Monitor.></p> <ul style="list-style-type: none"> • OBD-II general scan tool <p>For detailed operation procedures, refer to the OBD-II General Scan Tool Instruction Manual.</p>	<p>Is the engine coolant temperature less than -40°C (-40°F)?</p>	<p>Go to step 2.</p>	<p>Repair poor contact.</p> <p>NOTE:</p> <p>In this case, repair the following:</p> <ul style="list-style-type: none"> • Poor contact in engine coolant temperature sensor • Poor contact in ECM • Poor contact in coupling connector • Poor contact in joint connector
<p>2 CHECK HARNESS BETWEEN ENGINE COOLANT TEMPERATURE SENSOR AND ECM CONNECTOR.</p> <p>1) Turn the ignition switch to OFF.</p> <p>2) Disconnect the connector from engine coolant temperature sensor.</p> <p>3) Measure the voltage between engine coolant temperature sensor connector and engine ground.</p> <p>Connector & terminal (E8) No. 1 (+) — Engine ground (-):</p>	<p>Is the voltage more than 10 V?</p>	<p>Repair battery short circuit in harness between ECM and engine coolant temperature sensor connector.</p>	<p>Go to step 3.</p>
<p>3 CHECK HARNESS BETWEEN ENGINE COOLANT TEMPERATURE SENSOR AND ECM CONNECTOR.</p> <p>1) Turn the ignition switch to ON.</p> <p>2) Measure the voltage between engine coolant temperature sensor connector and engine ground.</p> <p>Connector & terminal (E8) No. 1 (+) — Engine ground (-):</p>	<p>Is the voltage more than 10 V?</p>	<p>Repair battery short circuit in harness between ECM and engine coolant temperature sensor connector.</p>	<p>Go to step 4.</p>
<p>4 CHECK HARNESS BETWEEN ENGINE COOLANT TEMPERATURE SENSOR AND ECM CONNECTOR.</p> <p>Measure the voltage between engine coolant temperature sensor connector and engine ground.</p> <p>Connector & terminal (E8) No. 1 (+) — Engine ground (-):</p>	<p>Is the voltage more than 4 V?</p>	<p>Go to step 5.</p>	<p>Repair harness and connector.</p> <p>NOTE:</p> <p>In this case, repair the following:</p> <ul style="list-style-type: none"> • Open circuit in harness between ECM and engine coolant temperature sensor connector • Poor contact in engine coolant temperature sensor connector • Poor contact in ECM connector • Poor contact in coupling connector • Poor contact in joint connector

Diagnostic Procedure with Diagnostic Trouble Code (DTC)

ENGINE (DIAGNOSTICS)

Step	Check	Yes	No
<p>5</p> <p>CHECK HARNESS BETWEEN ENGINE COOLANT TEMPERATURE SENSOR AND ECM CONNECTOR.</p> <p>1) Turn the ignition switch to OFF.</p> <p>2) Measure the resistance of harness between engine coolant temperature sensor connector and engine ground.</p> <p>Connector & terminal (E8) No. 2 — Engine ground:</p>	<p>Is the resistance less than 5 Ω?</p>	<p>Replace the engine coolant temperature sensor. <Ref. to FU(H4SO)-24, Engine Coolant Temperature Sensor.></p>	<p>Repair harness and connector.</p> <p>NOTE: In this case, repair the following:</p> <ul style="list-style-type: none"> • Open circuit in harness between ECM and engine coolant temperature sensor connector • Poor contact in engine coolant temperature sensor connector • Poor contact in ECM connector • Poor contact in coupling connector • Poor contact in joint connector

Diagnostic Procedure with Diagnostic Trouble Code (DTC)

ENGINE (DIAGNOSTICS)

Q: DTC P0121 THROTTLE/PEDAL POSITION SENSOR/SWITCH "A" CIRCUIT RANGE/PERFORMANCE

DTC DETECTING CONDITION:

- Two consecutive driving cycles with fault
- GENERAL DESCRIPTION <Ref. to GD(H4SO)-41, DTC P0121 THROTTLE/PEDAL POSITION SENSOR/SWITCH "A" CIRCUIT RANGE/PERFORMANCE, Diagnostic Trouble Code (DTC) Detecting Criteria.>

TROUBLE SYMPTOM:

- Erroneous idling
- Engine stalls.
- Poor driving performance

CAUTION:

After repair or replacement of faulty parts, conduct Clear Memory Mode <Ref. to EN(H4SO)(diag)-44, OPERATION, Clear Memory Mode.> and Inspection Mode <Ref. to EN(H4SO)(diag)-37, OPERATION, Inspection Mode.>.

WIRING DIAGRAM:

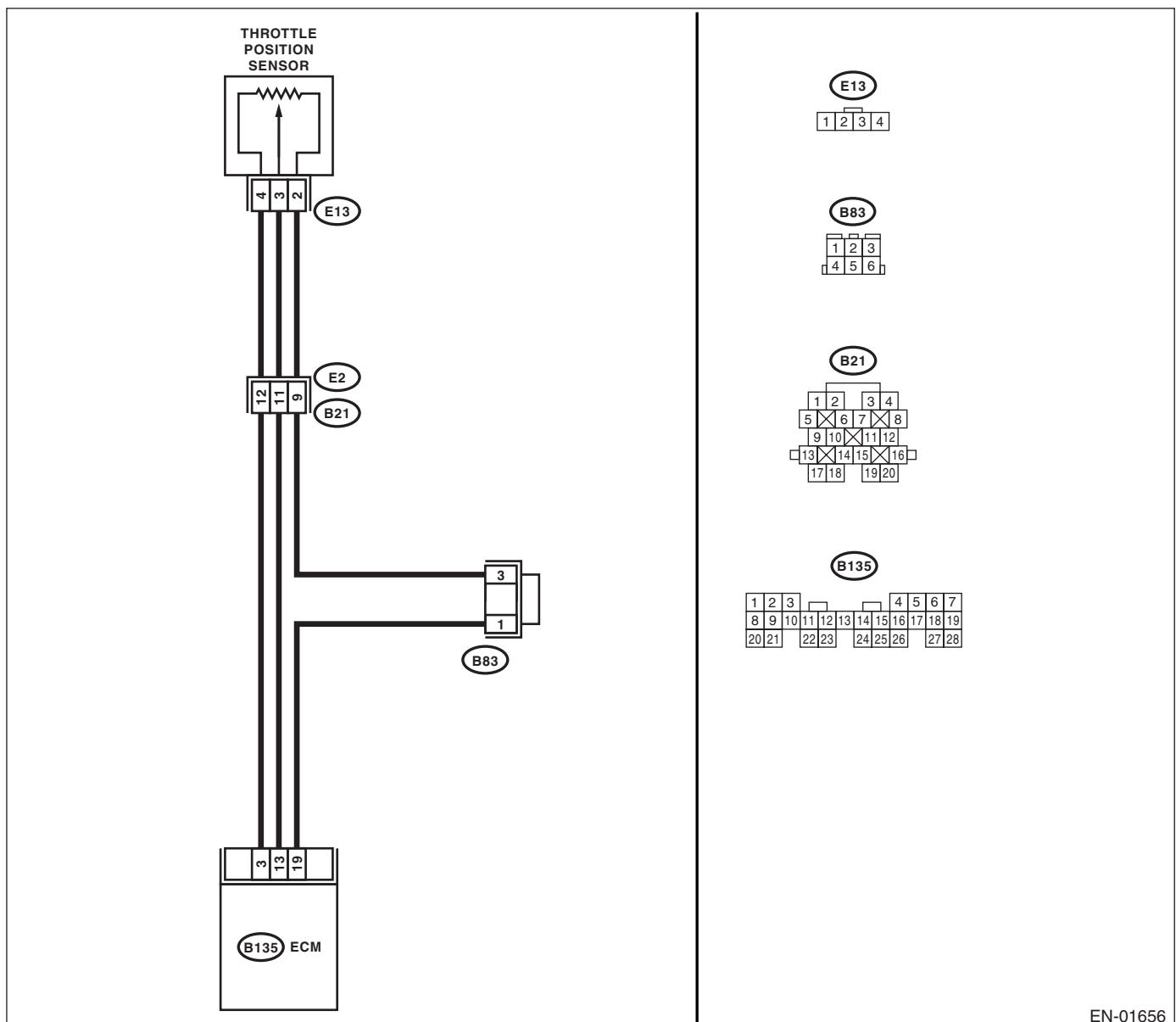

EN-01656

Diagnostic Procedure with Diagnostic Trouble Code (DTC)

ENGINE (DIAGNOSTICS)

Step	Check	Yes	No
1 CHECK ANY OTHER DTC ON DISPLAY.	Is any other DTC displayed?	Inspect DTC using "List of Diagnostic Trouble Code (DTC)". <Ref. to EN(H4SO)(diag)-71, List of Diagnostic Trouble Code (DTC).> NOTE: In this case, it is not necessary to inspect DTC P0121.	Replace the throttle position sensor. <Ref. to FU(H4SO)-28, Throttle Position Sensor.>

Diagnostic Procedure with Diagnostic Trouble Code (DTC)

ENGINE (DIAGNOSTICS)

R: DTC P0122 THROTTLE/PEDAL POSITION SENSOR/SWITCH "A" CIRCUIT LOW INPUT

DTC DETECTING CONDITION:

- Immediately at fault recognition
- GENERAL DESCRIPTION <Ref. to GD(H4SO)-43, DTC P0122 THROTTLE/PEDAL POSITION SENSOR/SWITCH "A" CIRCUIT LOW INPUT, Diagnostic Trouble Code (DTC) Detecting Criteria.>

TROUBLE SYMPTOM:

- Erroneous idling
- Engine stalls.
- Poor driving performance

CAUTION:

After repair or replacement of faulty parts, conduct Clear Memory Mode <Ref. to EN(H4SO)(diag)-44, OPERATION, Clear Memory Mode.> and Inspection Mode <Ref. to EN(H4SO)(diag)-37, OPERATION, Inspection Mode.>.

WIRING DIAGRAM:

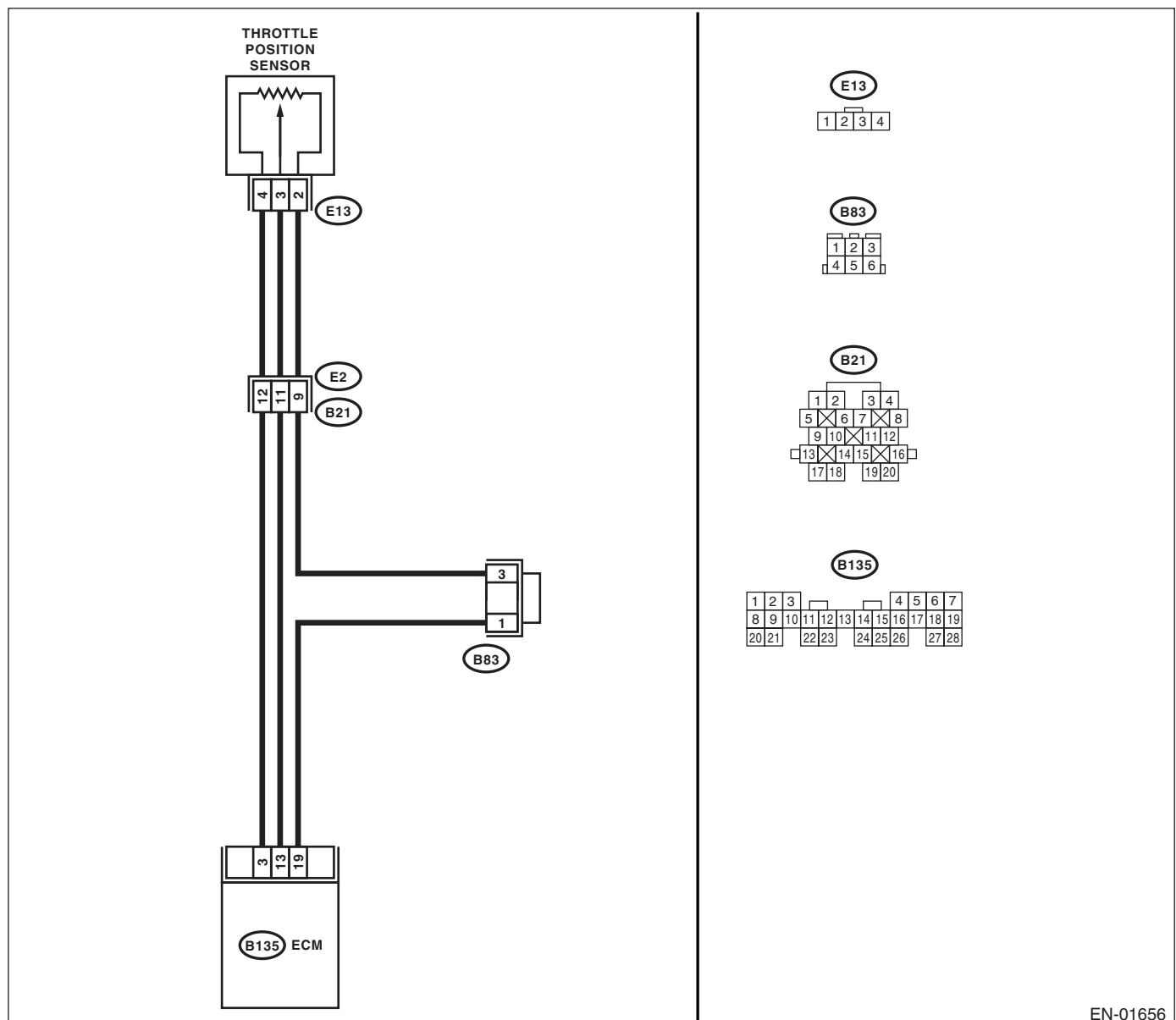

EN-01656

Diagnostic Procedure with Diagnostic Trouble Code (DTC)

ENGINE (DIAGNOSTICS)

Step	Check	Yes	No
<p>1</p> <p>CHECK CURRENT DATA. 1) Start the engine. 2) Read the data of throttle position sensor signal using Subaru Select Monitor or OBD-II general scan tool.</p> <p>NOTE: • Subaru Select Monitor For detailed operation procedure, refer to the "READ CURRENT DATA FOR ENGINE". <Ref. to EN(H4SO)(diag)-30, Subaru Select Monitor.> • OBD-II general scan tool For detailed operation procedures, refer to the OBD-II General Scan Tool Instruction Manual.</p>	<p>Is the voltage less than 0.1 V?</p>	<p>Go to step 2.</p>	<p>Even if malfunction indicator light lights up, the circuit has returned to a normal condition at this time. A temporary poor contact of the connector may be the cause.</p> <p>NOTE: In this case, repair the following: • Poor contact in throttle position sensor connector • Poor contact in ECM connector • Poor contact in coupling connector</p>
<p>2</p> <p>CHECK OUTPUT SIGNAL FOR ECM. Measure the voltage between ECM connector and chassis ground while throttle valve is fully closed.</p> <p>Connector & terminal (B135) No. 3 (+) — Chassis ground (-):</p>	<p>Is the voltage more than 4.5 V?</p>	<p>Go to step 4.</p>	<p>Go to step 3.</p>
<p>3</p> <p>CHECK OUTPUT SIGNAL FOR ECM. Measure the voltage between ECM connector and chassis ground.</p> <p>Connector & terminal (B135) No. 3 (+) — Chassis ground (-):</p>	<p>Does the voltage change by shaking the ECM harness and connector?</p>	<p>Repair poor contact in ECM connector.</p>	<p>Contact SOA Service Center.</p> <p>NOTE: Inspection by DTM is required, because probable cause is deterioration of multiple parts.</p>
<p>4</p> <p>CHECK INPUT SIGNAL FOR ECM. Measure the voltage between ECM connector and chassis ground.</p> <p>Connector & terminal (B135) No. 13 (+) — Chassis ground (-):</p>	<p>Is the voltage more than 0.1 V?</p>	<p>Go to step 6.</p>	<p>Go to step 5.</p>
<p>5</p> <p>CHECK INPUT SIGNAL FOR ECM. (USING SUBARU SELECT MONITOR.) Measure the voltage between ECM connector and chassis ground.</p> <p>Connector & terminal (B135) No. 13 (+) — Chassis ground (-):</p>	<p>Does the voltage change by shaking the ECM harness and connector?</p>	<p>Repair poor contact in ECM connector.</p>	<p>Go to step 6.</p>

Diagnostic Procedure with Diagnostic Trouble Code (DTC)

ENGINE (DIAGNOSTICS)

Step	Check	Yes	No
<p>6</p> <p>CHECK HARNESS BETWEEN ECM AND THROTTLE POSITION SENSOR CONNECTOR.</p> <p>1) Turn the ignition switch to OFF. 2) Disconnect the connectors from throttle position sensor. 3) Turn the ignition switch to ON. 4) Measure the voltage between throttle position sensor connector and engine ground.</p> <p>Connector & terminal (E13) No. 4 (+) — Engine ground (-):</p>	<p>Is the voltage more than 4.5 V?</p>	<p>Go to step 7.</p>	<p>Repair harness and connector.</p> <p>NOTE: In this case, repair the following:</p> <ul style="list-style-type: none"> • Open circuit in harness between throttle position sensor and ECM connector • Poor contact in throttle position sensor connector • Poor contact in ECM connector • Poor contact in coupling connector • Poor contact in joint connector
<p>7</p> <p>CHECK HARNESS BETWEEN ECM AND THROTTLE POSITION SENSOR CONNECTOR.</p> <p>1) Turn the ignition switch to OFF. 2) Measure the resistance of harness between ECM connector and throttle position sensor connector.</p> <p>Connector & terminal (B135) No. 13 — (E13) No. 3:</p>	<p>Is the resistance less than 1 Ω?</p>	<p>Go to step 8.</p>	<p>Repair harness and connector.</p> <p>NOTE: In this case, repair the following:</p> <ul style="list-style-type: none"> • Open circuit in harness between throttle position sensor and ECM connector • Poor contact in ECM connector • Poor contact in throttle position sensor connector • Poor contact in coupling connector
<p>8</p> <p>CHECK HARNESS BETWEEN ECM AND THROTTLE POSITION SENSOR CONNECTOR.</p> <p>Measure the resistance of harness between throttle position sensor connector and engine ground.</p> <p>Connector & terminal (E13) No. 3 — Engine ground:</p>	<p>Is the resistance more than 1 $M\Omega$?</p>	<p>Go to step 9.</p>	<p>Repair ground short circuit in harness between throttle position sensor and ECM connector.</p>
<p>9</p> <p>CHECK POOR CONTACT.</p> <p>Check poor contact in throttle position sensor connector.</p>	<p>Is there poor contact in throttle position sensor connector?</p>	<p>Repair poor contact in throttle position sensor connector.</p>	<p>Replace the throttle position sensor. <Ref. to FU(H4SO)-28, Throttle Position Sensor.></p>

Diagnostic Procedure with Diagnostic Trouble Code (DTC)

ENGINE (DIAGNOSTICS)

S: DTC P0123 THROTTLE/PEDAL POSITION SENSOR/SWITCH "A" CIRCUIT HIGH INPUT

DTC DETECTING CONDITION:

- Immediately at fault recognition
- GENERAL DESCRIPTION <Ref. to GD(H4SO)-45, DTC P0123 THROTTLE/PEDAL POSITION SENSOR/SWITCH "A" CIRCUIT HIGH INPUT, Diagnostic Trouble Code (DTC) Detecting Criteria.>

TROUBLE SYMPTOM:

- Erroneous idling
- Engine stalls.
- Poor driving performance

CAUTION:

After repair or replacement of faulty parts, conduct Clear Memory Mode <Ref. to EN(H4SO)(diag)-44, OPERATION, Clear Memory Mode.> and Inspection Mode <Ref. to EN(H4SO)(diag)-37, OPERATION, Inspection Mode.>.

WIRING DIAGRAM:

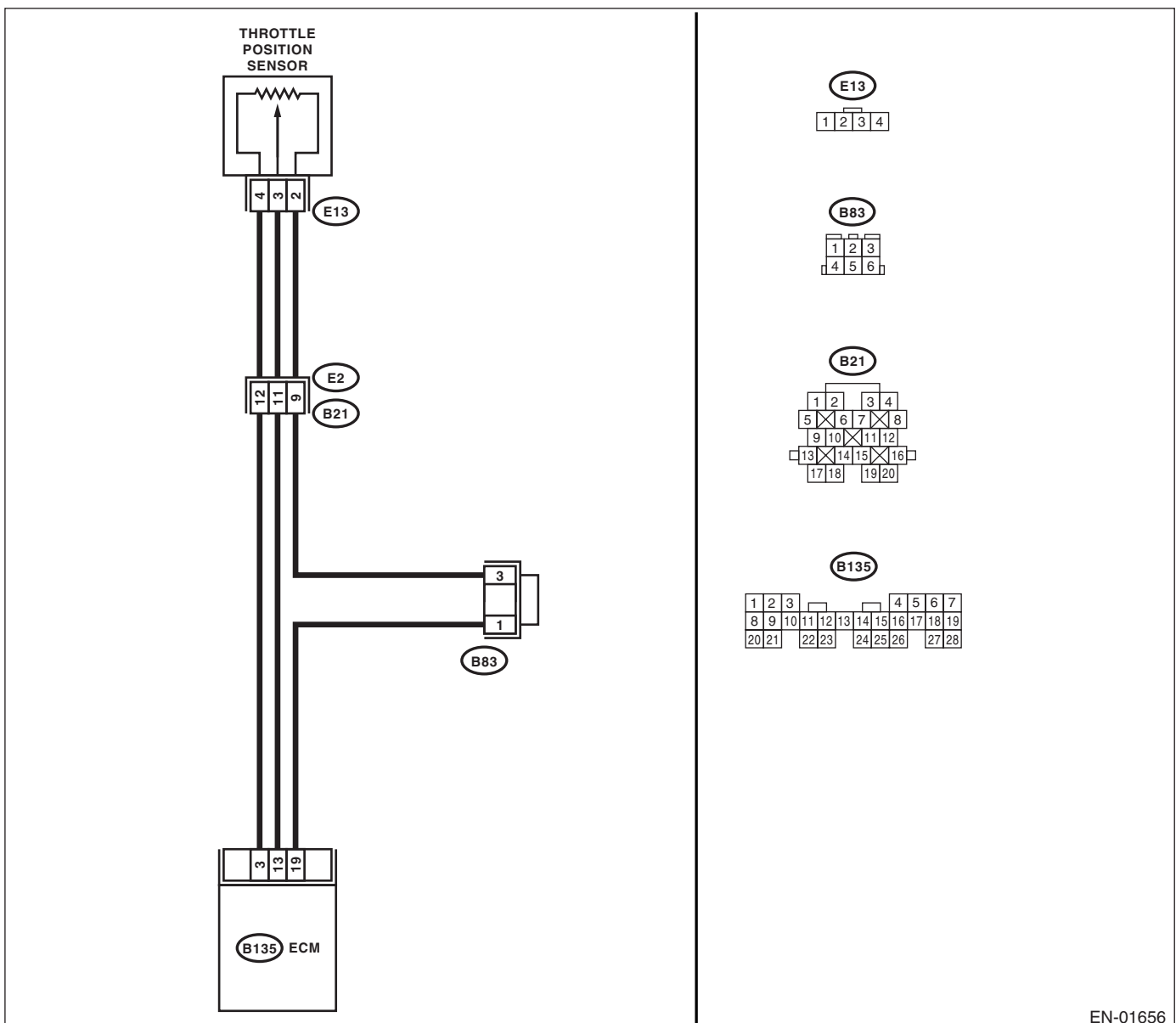

EN-01656

Diagnostic Procedure with Diagnostic Trouble Code (DTC)

ENGINE (DIAGNOSTICS)

Step	Check	Yes	No
<p>1</p> <p>CHECK CURRENT DATA.</p> <p>1) Start the engine.</p> <p>2) Read the data of throttle position sensor signal using Subaru Select Monitor or OBD-II general scan tool.</p> <p>NOTE:</p> <ul style="list-style-type: none"> Subaru Select Monitor <p>For detailed operation procedure, refer to the "READ CURRENT DATA FOR ENGINE". <Ref. to EN(H4SO)(diag)-30, Subaru Select Monitor.></p> <ul style="list-style-type: none"> OBD-II general scan tool <p>For detailed operation procedures, refer to the OBD-II General Scan Tool Instruction Manual.</p>	<p>Is the voltage more than 4.9 V?</p>	<p>Go to step 2.</p>	<p>Even if malfunction indicator light lights up, the circuit has returned to a normal condition at this time. A temporary poor contact of the connector may be the cause.</p> <p>NOTE:</p> <p>In this case, repair the following:</p> <ul style="list-style-type: none"> Poor contact in throttle position sensor connector Poor contact in ECM connector Poor contact in coupling connector
<p>2</p> <p>CHECK HARNESS BETWEEN THROTTLE POSITION SENSOR AND ECM CONNECTOR.</p> <p>1) Turn the ignition switch to OFF.</p> <p>2) Disconnect the connector from throttle position sensor.</p> <p>3) Measure the resistance of harness between throttle position sensor connector and engine ground.</p> <p>Connector & terminal</p> <p>(E13) No. 2 — Engine ground:</p>	<p>Is the resistance less than 5 Ω?</p>	<p>Go to step 3.</p>	<p>Repair harness and connector.</p> <p>NOTE:</p> <p>In this case, repair the following:</p> <ul style="list-style-type: none"> Open circuit in harness between throttle position sensor and ECM connector Poor contact in coupling connector Poor contact in joint connector
<p>3</p> <p>CHECK HARNESS BETWEEN THROTTLE POSITION SENSOR AND ECM CONNECTOR.</p> <p>1) Turn the ignition switch to ON.</p> <p>2) Measure the voltage between throttle position sensor connector and engine ground.</p> <p>Connector & terminal</p> <p>(E13) No. 3 (+) — Engine ground (-):</p>	<p>Is the voltage more than 4.9 V?</p>	<p>Repair battery short circuit in harness between throttle position sensor and ECM connector. After repair, replace the ECM. <Ref. to FU(H4SO)-44, Engine Control Module (ECM).></p>	<p>Replace the throttle position sensor. <Ref. to FU(H4SO)-28, Throttle Position Sensor.></p>

Diagnostic Procedure with Diagnostic Trouble Code (DTC)

ENGINE (DIAGNOSTICS)

T: DTC P0125 INSUFFICIENT COOLANT TEMPERATURE FOR CLOSED LOOP FUEL CONTROL

DTC DETECTING CONDITION:

- Two consecutive driving cycles with fault
- GENERAL DESCRIPTION <Ref. to GD(H4SO)-47, DTC P0125 INSUFFICIENT COOLANT TEMPERATURE FOR CLOSED LOOP FUEL CONTROL, Diagnostic Trouble Code (DTC) Detecting Criteria.>

TROUBLE SYMPTOM:

Engine would not return to idling.

CAUTION:

After repair or replacement of faulty parts, conduct Clear Memory Mode <Ref. to EN(H4SO)(diag)-44, OPERATION, Clear Memory Mode.> and Inspection Mode <Ref. to EN(H4SO)(diag)-37, OPERATION, Inspection Mode.>.

WIRING DIAGRAM:

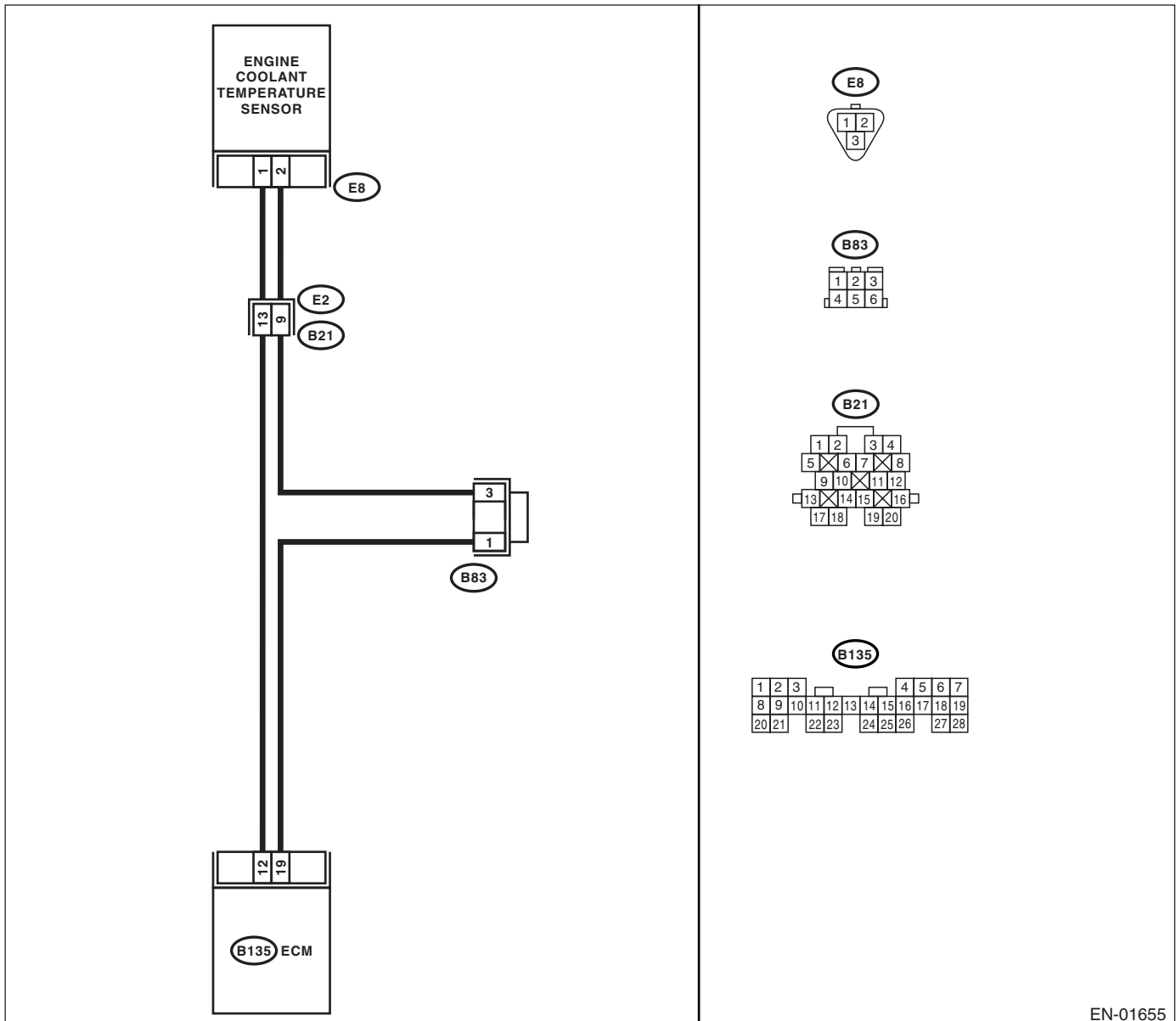

EN-01655

Diagnostic Procedure with Diagnostic Trouble Code (DTC)

ENGINE (DIAGNOSTICS)

Step	Check	Yes	No
1 CHECK ANY OTHER DTC ON DISPLAY.	Is any other DTC displayed?	Check DTC using "List of Diagnostic Trouble Code (DTC)". <Ref. to EN(H4SO)(diag)-71, List of Diagnostic Trouble Code (DTC).> NOTE: In this case, it is not necessary to inspect DTC P0125.	Go to step 2.
2 CHECK THERMOSTAT.	Does the thermostat remain opened?	Replace the thermostat. <Ref. to CO(H4SO)-17, Thermostat.>	Replace the engine coolant temperature sensor. <Ref. to FU(H4SO)-24, Engine Coolant Temperature Sensor.>

Diagnostic Procedure with Diagnostic Trouble Code (DTC)

ENGINE (DIAGNOSTICS)

U: DTC P0128 COOLANT THERMOSTAT (COOLANT TEMPERATURE BELOW THERMOSTAT REGULATING TEMPERATURE)

DTC DETECTING CONDITION:

- Two consecutive driving cycles with fault
- GENERAL DESCRIPTION <Ref. to GD(H4SO)-48, DTC P0128 COOLANT THERMOSTAT (COOLANT TEMPERATURE BELOW THERMOSTAT REGULATING TEMPERATURE), Diagnostic Trouble Code (DTC) Detecting Criteria.>

TROUBLE SYMPTOM:

Thermostat remains open.

CAUTION:

After repair or replacement of faulty parts, conduct CLEAR MEMORY MODE <Ref. to EN(H4SO)(diag)-44, OPERATION, Clear Memory Mode.> and INSPECTION MODE <Ref. to EN(H4SO)(diag)-37, OPERATION, Inspection Mode.>

Step	Check	Yes	No	
1	CHECK VEHICLE CONDITION.	Was the vehicle driven or idled with the engine partially submerged under water?	In this case, it is not necessary to inspect DTC P0128.	Go to step 2.
2	CHECK FOR OTHER DTC ON DISPLAY.	Is any other DTC displayed?	Inspect DTC using "List of Diagnostic Trouble Code (DTC)". <Ref. to EN(H4SO)(diag)-71, List of Diagnostic Trouble Code (DTC).>	Go to step 3.
3	CHECK ENGINE COOLANT.	Are coolant level and mixture ratio of cooling water to anti-freeze solution correct?	Go to step 4.	Replace the engine coolant. <Ref. to CO(H4SO)-12, REPLACEMENT.>
4	CHECK RADIATOR FAN. 1) Start the engine. 2) Check radiator fan operation.	Does the radiator fan continuously rotate for more than 3 minutes during idling?	Repair radiator fan circuit. <Ref. to CO(H4SO)-22, Radiator Main Fan and Fan Motor.> and <Ref. to CO(H4SO)-23, Radiator Sub Fan and Fan Motor.>	Replace the thermostat. <Ref. to CO(H4SO)-17, Thermostat.>

Diagnostic Procedure with Diagnostic Trouble Code (DTC)

ENGINE (DIAGNOSTICS)

V: DTC P0129 ATMOSPHERIC PRESSURE SENSOR CIRCUIT RANGE/PERFORMANCE

DTC DETECTING CONDITION:

- Two consecutive driving cycles with fault
- GENERAL DESCRIPTION <Ref. to GD(H4SO)-50, DTC P0129 BAROMETRIC PRESSURE TOO LOW, Diagnostic Trouble Code (DTC) Detecting Criteria.>

CAUTION:

After repair or replacement of faulty parts, conduct Clear Memory Mode <Ref. to EN(H4SO)(diag)-44, OPERATION, Clear Memory Mode.> and Inspection Mode <Ref. to EN(H4SO)(diag)-37, OPERATION, Inspection Mode.>.

Step	Check	Yes	No
1 CHECK ANY OTHER DTC ON DISPLAY.	Is any other DTC displayed?	Check DTC using "List of Diagnostic Trouble Code (DTC)". <Ref. to EN(H4SO)(diag)-71, List of Diagnostic Trouble Code (DTC).> NOTE: It is not necessary to inspect DTC P0129.	Replace the ECM. <Ref. to FU(H4SO)-44, Engine Control Module (ECM).>

Diagnostic Procedure with Diagnostic Trouble Code (DTC)

ENGINE (DIAGNOSTICS)

W: DTC P0130 O₂ SENSOR CIRCUIT (BANK 1 SENSOR 1)

DTC DETECTING CONDITION:

- Immediately at fault recognition
- GENERAL DESCRIPTION <Ref. to GD(H4SO)-51, DTC P0130 O₂ SENSOR CIRCUIT (BANK 1 SENSOR 1), Diagnostic Trouble Code (DTC) Detecting Criteria.>

CAUTION:

After repair or replacement of faulty parts, conduct Clear Memory Mode <Ref. to EN(H4SO)(diag)-44, OPERATION, Clear Memory Mode.> and Inspection Mode <Ref. to EN(H4SO)(diag)-37, OPERATION, Inspection Mode.>.

WIRING DIAGRAM:

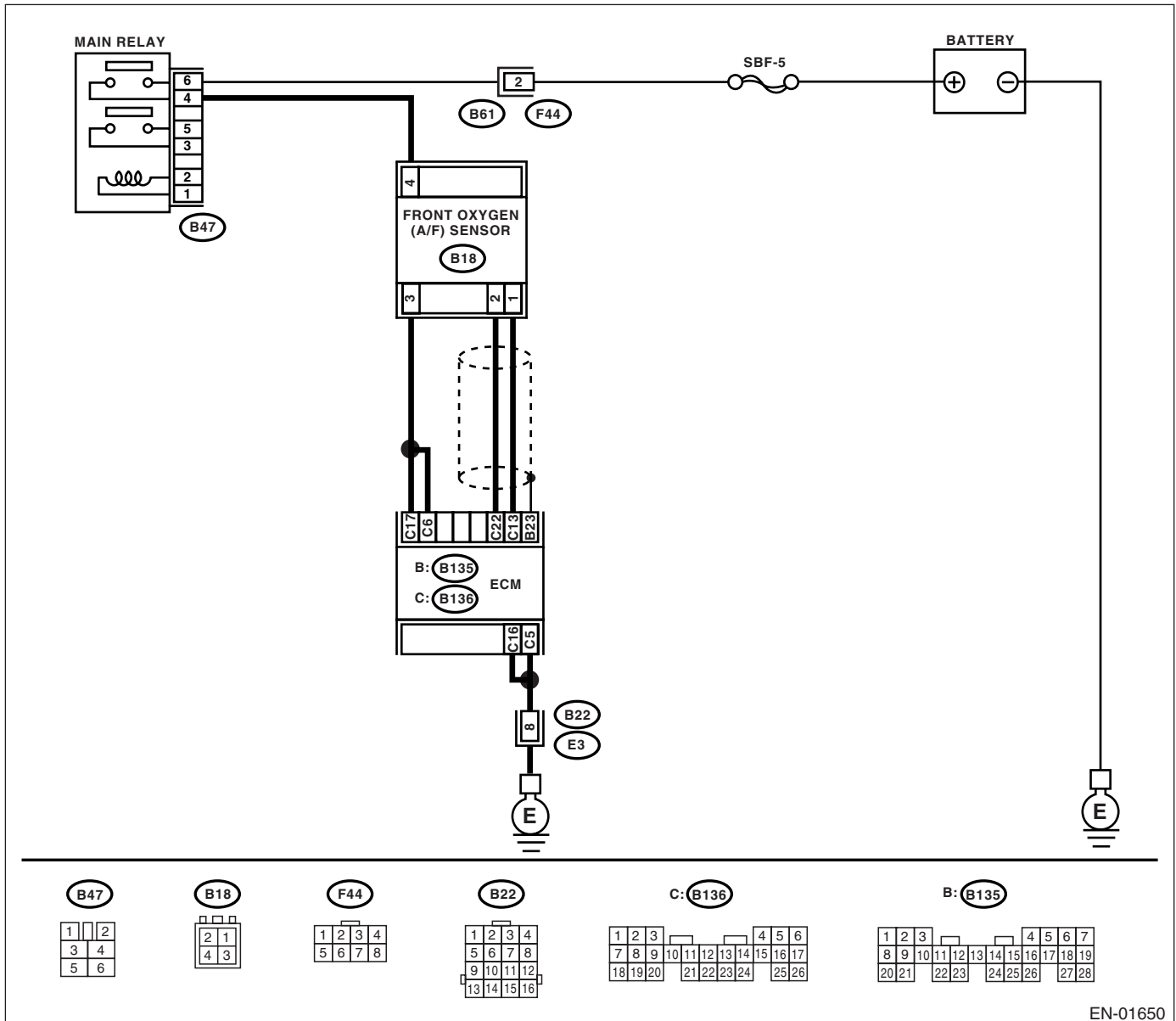

EN-01650

Diagnostic Procedure with Diagnostic Trouble Code (DTC)

ENGINE (DIAGNOSTICS)

Step	Check	Yes	No
1 CHECK ANY OTHER DTC ON DISPLAY.	Is any other DTC displayed?	Check DTC using "List of Diagnostic Trouble Code (DTC)". <Ref. to EN(H4SO)(diag)-71, List of Diagnostic Trouble Code (DTC).>	Go to step 2.
2 CHECK FRONT OXYGEN (A/F) SENSOR DATA. 1) Start the engine. 2) While observing the Subaru Select Monitor or OBD-II general scan tool screen, warm-up the engine until coolant temperature is above 70°C (160°F). If the engine is already warmed-up, operate at idle speed for at least 1 minute. 3) Read the data of front oxygen (A/F) sensor signal using Subaru Select Monitor or OBD-II general scan tool. NOTE: • Subaru Select Monitor For detailed operation procedure, refer to the "READ CURRENT DATA FOR ENGINE". <Ref. to EN(H4SO)(diag)-30, Subaru Select Monitor.> • OBD-II general scan tool For detailed operation procedures, refer to the OBD-II General Scan Tool Instruction Manual.	Is the voltage 0.85 — 1.15 V?	Go to step 3.	Go to step 4.
3 CHECK FRONT OXYGEN (A/F) SENSOR DATA. 1) Race the engine at speeds from idling to 5,000 rpm for a total of 5 cycles. 2) Read the data of front oxygen (A/F) sensor signal during racing using Subaru Select Monitor or OBD-II general scan tool. NOTE: • Air fuel ratio is rich at normal condition or during racing. • To increase engine speed to 5,000 rpm, slowly depress accelerator pedal, taking approximately 5 seconds, and quickly release accelerator pedal to decrease engine speed.	Is the voltage more than 1.1 V?	Go to step 6.	Go to step 4.
4 CHECK HARNESS BETWEEN ECM AND FRONT OXYGEN (A/F) SENSOR. 1) Turn the ignition switch to OFF. 2) Disconnect the connector from ECM and front oxygen (A/F) sensor connector. 3) Measure the resistance between ECM and front oxygen (A/F) sensor. Connector & terminals (B136) No. 13 — (B18) No. 1: (B136) No. 22 — (B18) No. 2:	Is the resistance less than 5 Ω?	Go to step 5.	Repair open circuit between ECM and front oxygen (A/F) sensor.
5 CHECK HARNESS BETWEEN ECM AND FRONT OXYGEN (A/F) SENSOR. Measure the resistance between ECM and chassis ground. Connector & terminals (B136) No. 13 — Chassis ground: (B136) No. 22 — Chassis ground:	Is the resistance more than 1 MΩ?	Go to step 6.	Repair ground short circuit between ECM and front oxygen (A/F) sensor.

Diagnostic Procedure with Diagnostic Trouble Code (DTC)

ENGINE (DIAGNOSTICS)

	Step	Check	Yes	No
6	CHECK EXHAUST SYSTEM. Check exhaust system parts. NOTE: Check the following items. <ul style="list-style-type: none">• Loose installation of portions• Damage (crack, hole etc.) of parts• Looseness of front oxygen (A/F) sensor• Looseness and ill fitting of parts between front oxygen (A/F) sensor and rear oxygen sensor	Is there a fault in exhaust system?	Repair or replace faulty parts.	Replace the front oxygen (A/F) sensor. <Ref. to FU(H4SO)-40, Front Oxygen (A/F) Sensor.>

Diagnostic Procedure with Diagnostic Trouble Code (DTC)

ENGINE (DIAGNOSTICS)

X: DTC P0131 O₂ SENSOR CIRCUIT LOW VOLTAGE (BANK 1 SENSOR 1)

DTC DETECTING CONDITION:

- Immediately at fault recognition
- GENERAL DESCRIPTION <Ref. to GD(H4SO)-53, DTC P0131 O₂ SENSOR CIRCUIT LOW VOLTAGE (BANK 1 SENSOR 1), Diagnostic Trouble Code (DTC) Detecting Criteria.>

CAUTION:

After repair or replacement of faulty parts, conduct Clear Memory Mode <Ref. to EN(H4SO)(diag)-44, OPERATION, Clear Memory Mode.> and Inspection Mode <Ref. to EN(H4SO)(diag)-37, OPERATION, Inspection Mode.>.

WIRING DIAGRAM:

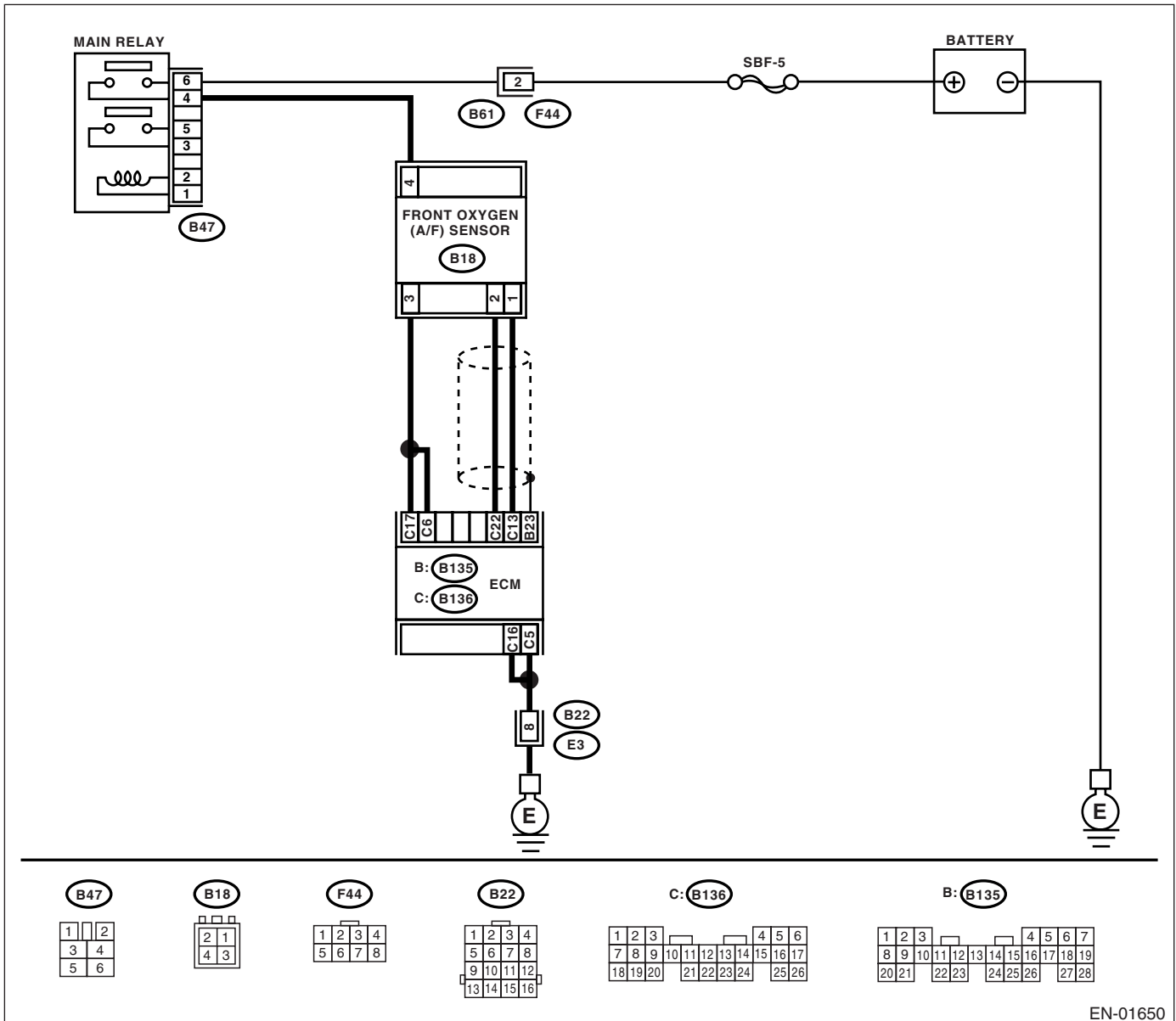

EN-01650

Diagnostic Procedure with Diagnostic Trouble Code (DTC)

ENGINE (DIAGNOSTICS)

Step	Check	Yes	No
<p>1</p> <p>CHECK HARNESS BETWEEN ECM AND FRONT OXYGEN (A/F) SENSOR CONNECTOR.</p> <p>1) Turn the ignition switch to OFF. 2) Disconnect the connectors from ECM and front oxygen (A/F) sensor connector. 3) Measure the resistance of harness between ECM and front oxygen (A/F) sensor connector.</p> <p>Connector & terminal (B136) No. 13 — Chassis ground: (B136) No. 22 — Chassis ground:</p>	<p>Is the resistance more than 1 MΩ?</p>	<p>Replace the front oxygen (A/F) sensor. <Ref. to FU(H4SO)-40, Front Oxygen (A/F) Sensor.></p>	<p>Repair ground short circuit in harness between ECM and front oxygen (A/F) sensor connector.</p>

Diagnostic Procedure with Diagnostic Trouble Code (DTC)

ENGINE (DIAGNOSTICS)

Y: DTC P0132 O₂ SENSOR CIRCUIT HIGH VOLTAGE (BANK 1 SENSOR 1)

DTC DETECTING CONDITION:

- Immediately at fault recognition
- GENERAL DESCRIPTION <Ref. to GD(H4SO)-55, DTC P0132 O₂ SENSOR CIRCUIT HIGH VOLTAGE (BANK 1 SENSOR 1), Diagnostic Trouble Code (DTC) Detecting Criteria.>

CAUTION:

After repair or replacement of faulty parts, conduct Clear Memory Mode <Ref. to EN(H4SO)(diag)-44, OPERATION, Clear Memory Mode.> and Inspection Mode <Ref. to EN(H4SO)(diag)-37, OPERATION, Inspection Mode.>.

WIRING DIAGRAM:

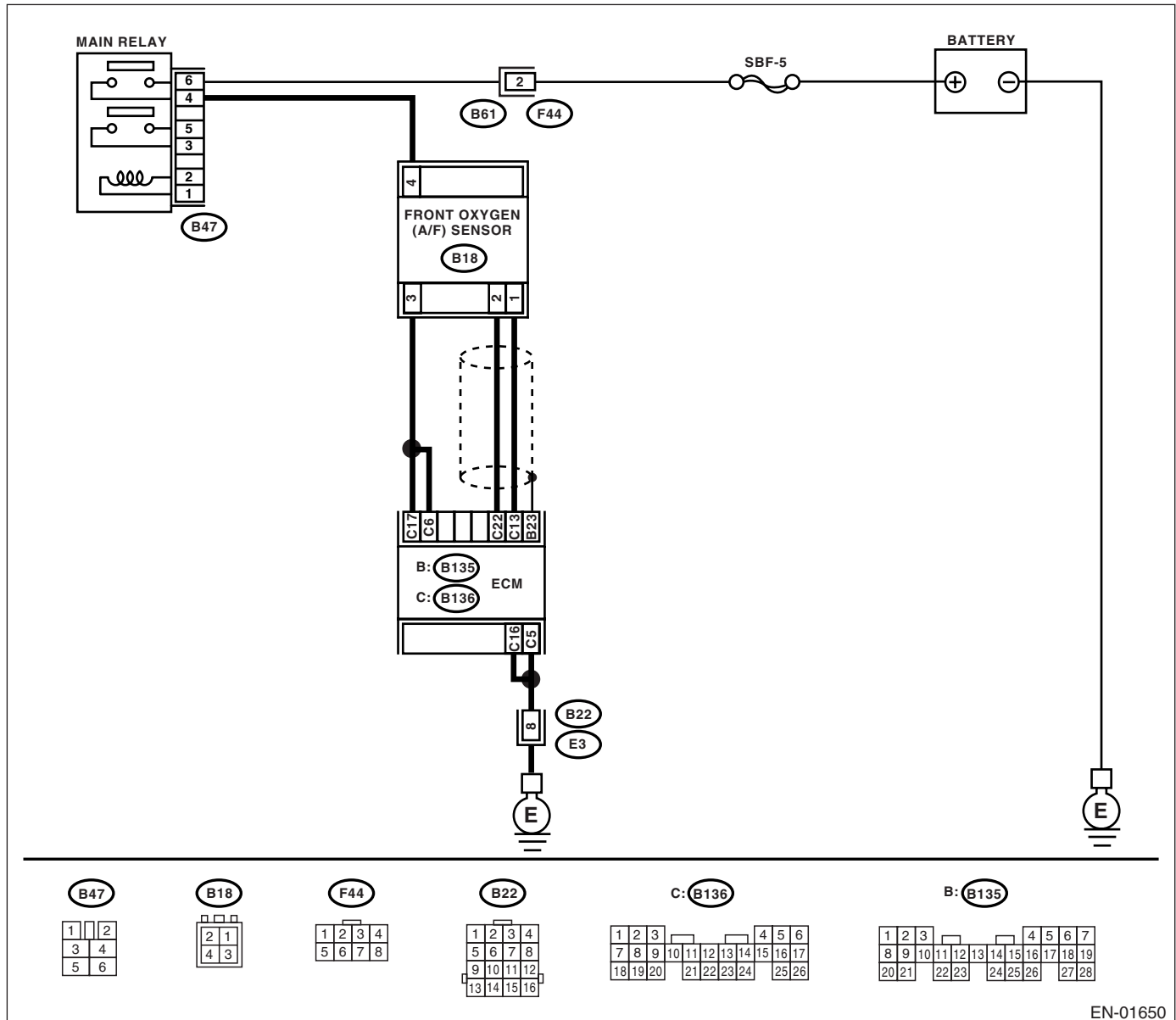

EN-01650

Diagnostic Procedure with Diagnostic Trouble Code (DTC)

ENGINE (DIAGNOSTICS)

Step	Check	Yes	No
<p>1</p> <p>CHECK HARNESS BETWEEN ECM AND FRONT OXYGEN (A/F) SENSOR CONNECTOR.</p> <p>1) Turn the ignition switch to ON. 2) Disconnect the connectors from front oxygen (A/F) sensor. 3) Measure the voltage of harness between ECM connector and chassis ground.</p> <p>Connector & terminal (B136) No. 13 (+) — Chassis ground (-): (B136) No. 22 (+) — Chassis ground (-):</p>	<p>Is the voltage more than 8 V?</p>	<p>Replace the front oxygen (A/F) sensor. <Ref. to FU(H4SO)-40, Front Oxygen (A/F) Sensor.></p>	<p>Repair battery short circuit in harness between ECM and front oxygen (A/F) sensor connector.</p>

Diagnostic Procedure with Diagnostic Trouble Code (DTC)

ENGINE (DIAGNOSTICS)

Z: DTC P0133 O₂ SENSOR CIRCUIT SLOW RESPONSE (BANK 1 SENSOR 1)

DTC DETECTING CONDITION:

- Two consecutive driving cycles with fault
- GENERAL DESCRIPTION <Ref. to GD(H4SO)-57, DTC P0133 O₂ SENSOR CIRCUIT SLOW RESPONSE (BANK 1 SENSOR 1), Diagnostic Trouble Code (DTC) Detecting Criteria.>

CAUTION:

After repair or replacement of faulty parts, conduct Clear Memory Mode <Ref. to EN(H4SO)(diag)-44, OPERATION, Clear Memory Mode.> and Inspection Mode <Ref. to EN(H4SO)(diag)-37, OPERATION, Inspection Mode.>.

WIRING DIAGRAM:

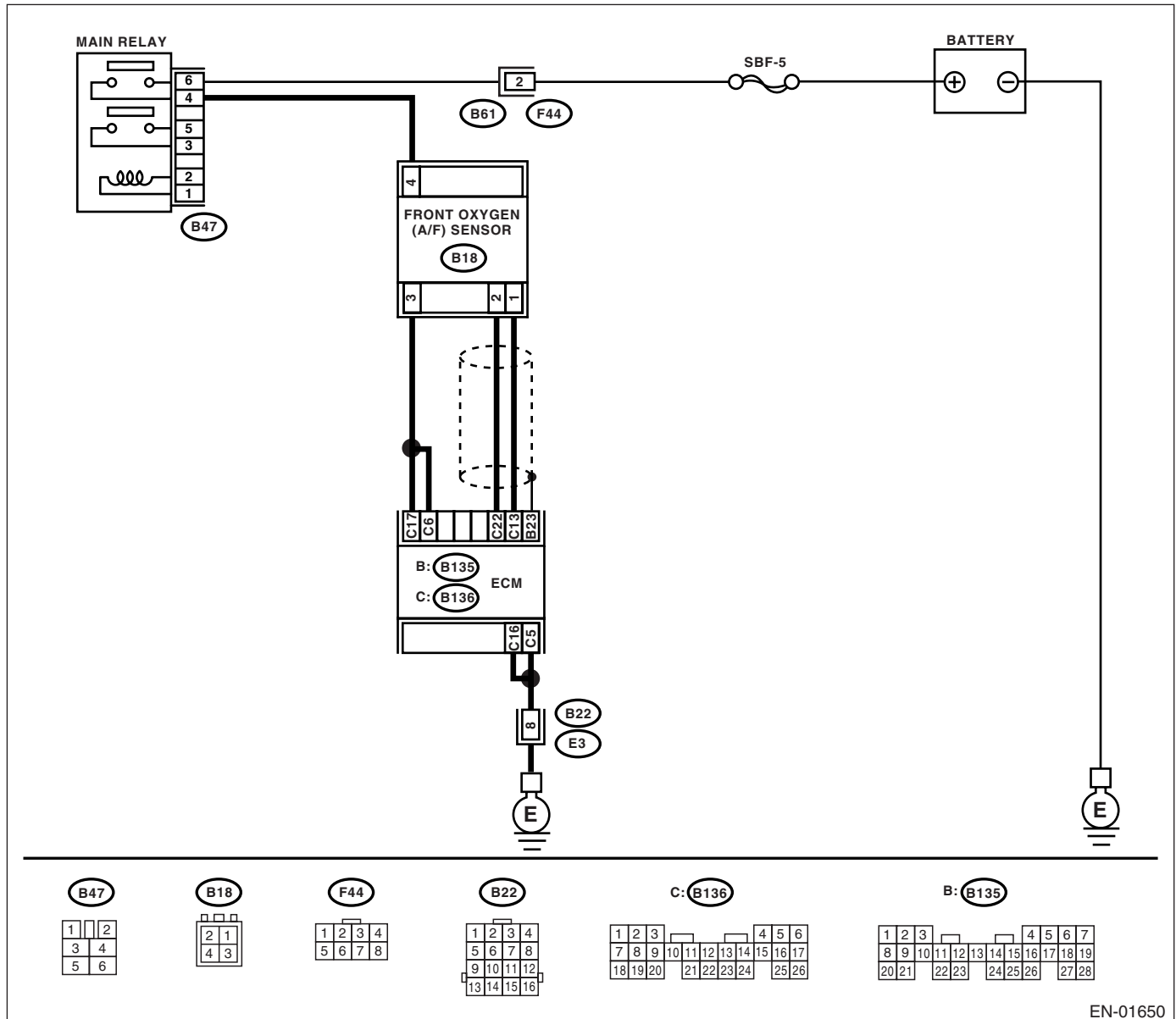

EN-01650

Diagnostic Procedure with Diagnostic Trouble Code (DTC)

ENGINE (DIAGNOSTICS)

Step	Check	Yes	No
1 CHECK ANY OTHER DTC ON DISPLAY.	Is any other DTC displayed?	Check DTC using "List of Diagnostic Trouble Code (DTC)". <Ref. to EN(H4SO)(diag)-71, List of Diagnostic Trouble Code (DTC).> NOTE: In this case, it is not necessary to inspect DTC P0133.	Go to step 2.
2 CHECK EXHAUST SYSTEM. NOTE: Check the following items. <ul style="list-style-type: none"> • Loose installation of front portion of exhaust pipe onto cylinder heads • Loose connection between front exhaust pipe and front catalytic converter • Damage of exhaust pipe resulting in a hole 	Is there a fault in exhaust system?	Repair exhaust system.	Replace the front oxygen (A/F) sensor. <Ref. to FU(H4SO)-40, Front Oxygen (A/F) Sensor.>

Diagnostic Procedure with Diagnostic Trouble Code (DTC)

ENGINE (DIAGNOSTICS)

Step	Check	Yes	No
<p>1</p> <p>CHECK HARNESS BETWEEN ECM AND FRONT OXYGEN (A/F) SENSOR CONNECTOR.</p> <p>1) Turn the ignition switch to OFF. 2) Disconnect the connectors from ECM and front oxygen (A/F) sensor connector. 3) Measure the resistance of harness between ECM and front oxygen (A/F) sensor connector.</p> <p>Connector & terminal (B136) No. 13 — (B18) No. 1: (B136) No. 22 — (B18) No. 2:</p>	<p>Is the resistance less than 1 Ω?</p>	<p>Go to step 2.</p>	<p>Repair harness and connector.</p> <p>NOTE: In this case, repair the following:</p> <ul style="list-style-type: none"> • Open circuit in harness between ECM and front oxygen (A/F) sensor connector • Poor contact in front oxygen (A/F) sensor connector • Poor contact in ECM connector
<p>2</p> <p>CHECK POOR CONTACT. Check poor contact in front oxygen (A/F) sensor connector.</p>	<p>Is there poor contact in front oxygen (A/F) sensor connector?</p>	<p>Repair poor contact in front oxygen (A/F) sensor connector.</p>	<p>Replace the front oxygen (A/F) sensor. <Ref. to FU(H4SO)-40, Front Oxygen (A/F) Sensor.></p>

Diagnostic Procedure with Diagnostic Trouble Code (DTC)

ENGINE (DIAGNOSTICS)

AB:DTC P0137 O₂ SENSOR CIRCUIT LOW VOLTAGE (BANK 1 SENSOR 2)

DTC DETECTING CONDITION:

- Two consecutive driving cycles with fault
- GENERAL DESCRIPTION <Ref. to GD(H4SO)-63, DTC P0137 O₂ SENSOR CIRCUIT LOW VOLTAGE (BANK 1 SENSOR 2), Diagnostic Trouble Code (DTC) Detecting Criteria.>

CAUTION:

After repair or replacement of faulty parts, conduct Clear Memory Mode <Ref. to EN(H4SO)(diag)-44, OPERATION, Clear Memory Mode.> and Inspection Mode <Ref. to EN(H4SO)(diag)-37, OPERATION, Inspection Mode.>.

WIRING DIAGRAM:

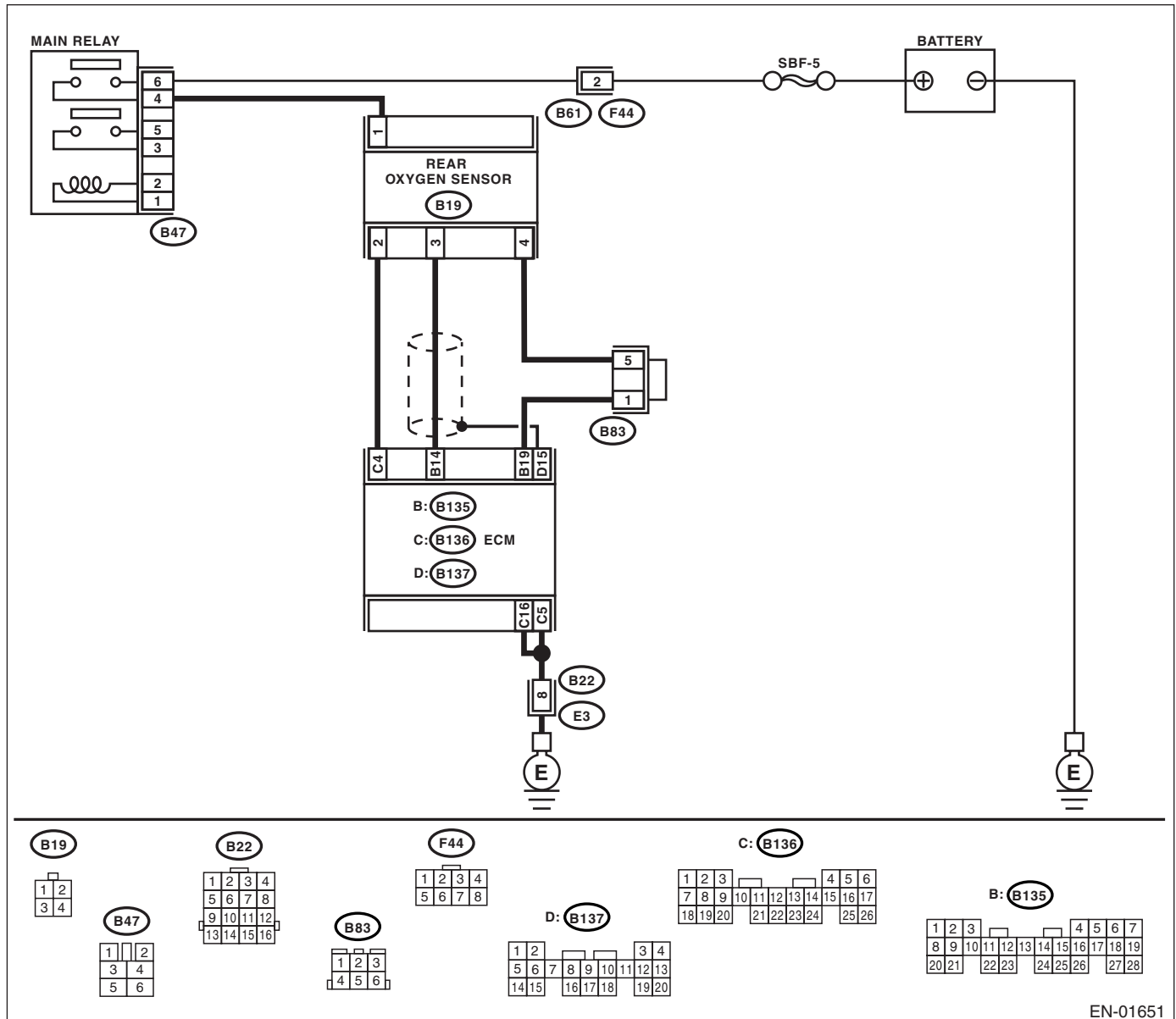

EN-01651

Diagnostic Procedure with Diagnostic Trouble Code (DTC)

ENGINE (DIAGNOSTICS)

Step	Check	Yes	No
1 CHECK ANY OTHER DTC ON DISPLAY.	Is any other DTC displayed?	Check DTC using "List of Diagnostic Trouble Code (DTC)". <Ref. to EN(H4SO)(diag)-71, List of Diagnostic Trouble Code (DTC).> NOTE: In this case, it is not necessary to inspect DTC P0137.	Go to step 2.
2 CHECK REAR OXYGEN SENSOR DATA. 1) Warm-up the engine until engine coolant temperature is above 70°C (158°F), and keep the engine speed at 5,000 rpm. 2) Read the data of rear oxygen sensor signal using Subaru Select Monitor or OBD-II general scan tool. NOTE: • Subaru Select Monitor For detailed operation procedure, refer to the "READ CURRENT DATA SHOWN ON DISPLAY FOR ENGINE". <Ref. to EN(H4SO)(diag)-30, Subaru Select Monitor.> • OBD-II general scan tool For detailed operation procedures, refer to the OBD-II General Scan Tool Instruction Manual.	Is the voltage 490 mV?	Go to step 5.	Go to step 3.
3 CHECK HARNESS BETWEEN ECM AND REAR OXYGEN SENSOR CONNECTOR. 1) Turn the ignition switch to OFF. 2) Disconnect the connectors from ECM and rear oxygen sensor. 3) Measure the resistance of harness between ECM and rear oxygen sensor connector. Connector & terminal (B135) No. 14 — (B19) No. 3: (B135) No. 19 — (B19) No. 4:	Is the resistance more than 3 Ω?	Repair open circuit in harness between ECM and rear oxygen sensor connector.	Go to step 4.
4 CHECK HARNESS BETWEEN REAR OXYGEN SENSOR AND ECM CONNECTOR. 1) Turn the ignition switch to OFF. 2) Disconnect the connector from rear oxygen sensor. 3) Turn the ignition switch to ON. 4) Measure the voltage between rear oxygen sensor harness connector and engine ground or chassis ground. Connector & terminal (B19) No. 3 (+) — Engine ground (-):	Is the voltage 0.2 — 0.5 V?	Replace the rear oxygen sensor. <Ref. to FU(H4SO)-42, Rear Oxygen Sensor.>	Repair harness and connector. NOTE: In this case, repair the following: • Open circuit in harness between rear oxygen sensor and ECM connector • Poor contact in rear oxygen sensor connector • Poor contact in ECM connector

Diagnostic Procedure with Diagnostic Trouble Code (DTC)

ENGINE (DIAGNOSTICS)

Step	Check	Yes	No
<p>5 CHECK EXHAUST SYSTEM. Check exhaust system parts.</p> <p>NOTE: Check the following items.</p> <ul style="list-style-type: none">• Loose installation of portions• Damage (crack, hole etc.) of parts• Looseness and ill fitting of parts between front oxygen (A/F) sensor and rear oxygen sensor	Is there a fault in exhaust system?	Repair or replace faulty parts.	Replace the rear oxygen sensor. <Ref. to FU(H4SO)-42, Rear Oxygen Sensor.>

Diagnostic Procedure with Diagnostic Trouble Code (DTC)

ENGINE (DIAGNOSTICS)

AC:DTC P0138 O₂ SENSOR CIRCUIT HIGH VOLTAGE (BANK 1 SENSOR 2)

DTC DETECTING CONDITION:

- Two consecutive driving cycles with fault
- GENERAL DESCRIPTION <Ref. to GD(H4SO)-65, DTC P0138 O₂ SENSOR CIRCUIT HIGH VOLTAGE (BANK 1 SENSOR 2), Diagnostic Trouble Code (DTC) Detecting Criteria.>

CAUTION:

After repair or replacement of faulty parts, conduct Clear Memory Mode <Ref. to EN(H4SO)(diag)-44, OPERATION, Clear Memory Mode.> and Inspection Mode <Ref. to EN(H4SO)(diag)-37, OPERATION, Inspection Mode.>.

WIRING DIAGRAM:

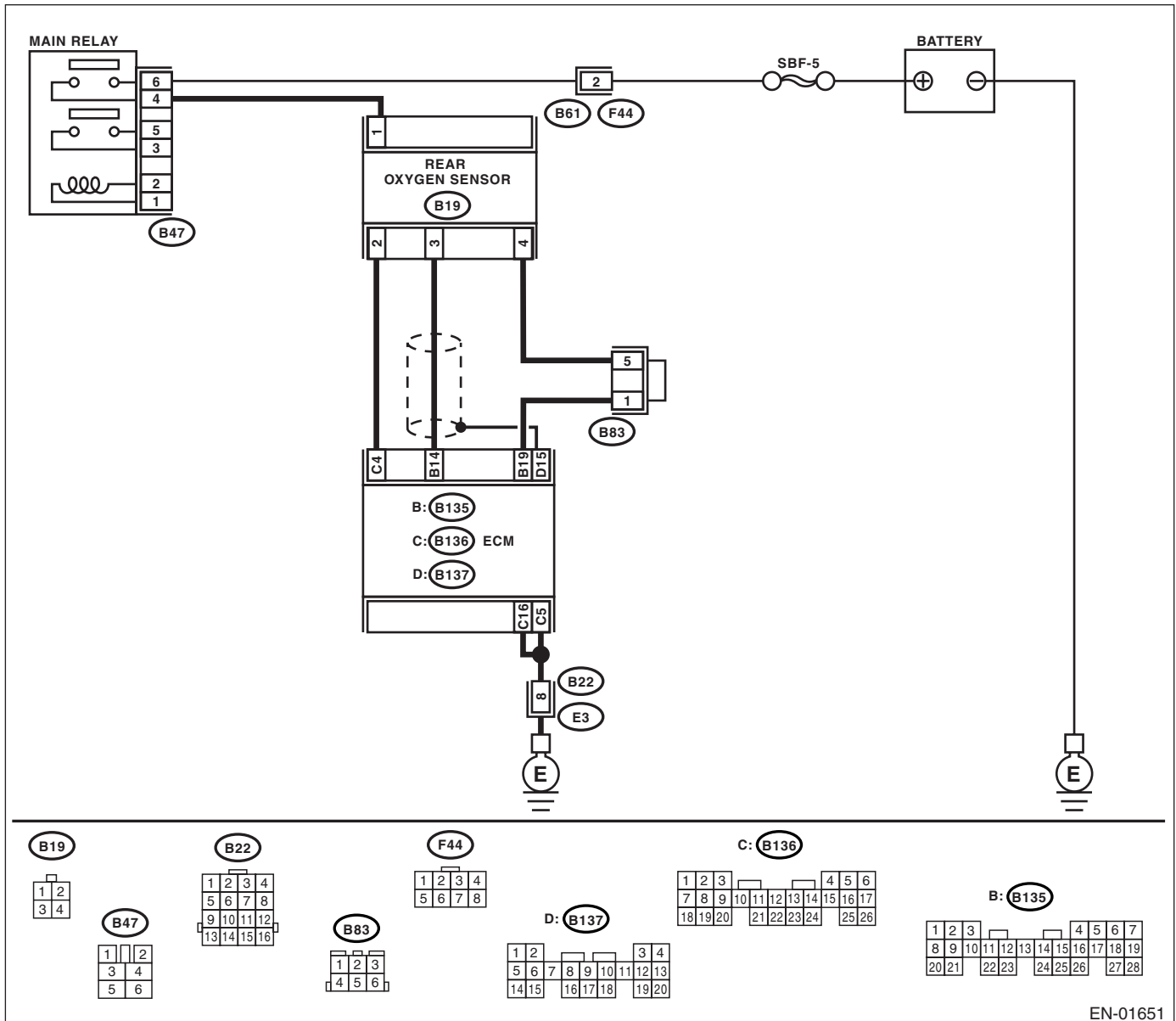

EN-01651

Diagnostic Procedure with Diagnostic Trouble Code (DTC)

ENGINE (DIAGNOSTICS)

Step	Check	Yes	No
1 CHECK ANY OTHER DTC ON DISPLAY.	Is any other DTC displayed?	Check DTC using "List of Diagnostic Trouble Code (DTC)". <Ref. to EN(H4SO)(diag)-71, List of Diagnostic Trouble Code (DTC).> NOTE: In this case, it is not necessary to inspect DTC P0138.	Go to step 2.
2 CHECK REAR OXYGEN SENSOR DATA. 1) Warm-up the engine until engine coolant temperature is above 70°C (158°F), and immediately decrease the engine speed from 5,000 rpm. 2) Read the data of rear oxygen sensor signal using Subaru Select Monitor or OBD-II general scan tool. NOTE: • Subaru Select Monitor For detailed operation procedure, refer to the "READ CURRENT DATA SHOWN ON DISPLAY FOR ENGINE". <Ref. to EN(H4SO)(diag)-30, Subaru Select Monitor.> • OBD-II general scan tool For detailed operation procedures, refer to the OBD-II General Scan Tool Instruction Manual.	Is the voltage 250 mV?	Go to step 5.	Go to step 3.
3 CHECK HARNESS BETWEEN ECM AND REAR OXYGEN SENSOR CONNECTOR. 1) Turn the ignition switch to OFF. 2) Disconnect the connectors from ECM and rear oxygen sensor. 3) Measure the resistance of harness between ECM and rear oxygen sensor connector. Connector & terminal (B135) No. 14 — (B19) No. 3: (B135) No. 19 — (B19) No. 4:	Is the resistance more than 3 Ω?	Repair open circuit in harness between ECM and rear oxygen sensor connector.	Go to step 4.
4 CHECK HARNESS BETWEEN REAR OXYGEN SENSOR AND ECM CONNECTOR. 1) Turn the ignition switch to OFF. 2) Disconnect the connector from rear oxygen sensor. 3) Turn the ignition switch to ON. 4) Measure the voltage between rear oxygen sensor harness connector and engine ground or chassis ground. Connector & terminal (B19) No. 3 (+) — Engine ground (-):	Is the voltage 0.2 — 0.5 V?	Replace the rear oxygen sensor. <Ref. to FU(H4SO)-42, Rear Oxygen Sensor.>	Repair harness and connector. NOTE: In this case, repair the following: • Open circuit in harness between rear oxygen sensor and ECM connector • Poor contact in rear oxygen sensor connector • Poor contact in ECM connector

Diagnostic Procedure with Diagnostic Trouble Code (DTC)

ENGINE (DIAGNOSTICS)

Step	Check	Yes	No
5 CHECK EXHAUST SYSTEM. Check exhaust system parts. NOTE: Check the following items. <ul style="list-style-type: none">• Loose installation of portions• Damage (crack, hole etc.) of parts• Looseness and ill fitting of parts between front oxygen (A/F) sensor and rear oxygen sensor	Is there a fault in exhaust system?	Repair or replace faulty parts.	Replace the rear oxygen sensor. <Ref. to FU(H4SO)-42, Rear Oxygen Sensor.>

Diagnostic Procedure with Diagnostic Trouble Code (DTC)

ENGINE (DIAGNOSTICS)

AD:DTC P0139 O₂ SENSOR CIRCUIT SLOW RESPONSE (BANK 1 SENSOR 2)

DTC DETECTING CONDITION:

- Two consecutive driving cycles with fault
- GENERAL DESCRIPTION <Ref. to GD(H4SO)-67, DTC P0139 O₂ SENSOR CIRCUIT SLOW RESPONSE (BANK 1 SENSOR 2), Diagnostic Trouble Code (DTC) Detecting Criteria.>

CAUTION:

After repair or replacement of faulty parts, conduct Clear Memory Mode <Ref. to EN(H4SO)(diag)-44, OPERATION, Clear Memory Mode.> and Inspection Mode <Ref. to EN(H4SO)(diag)-37, OPERATION, Inspection Mode.>.

WIRING DIAGRAM:

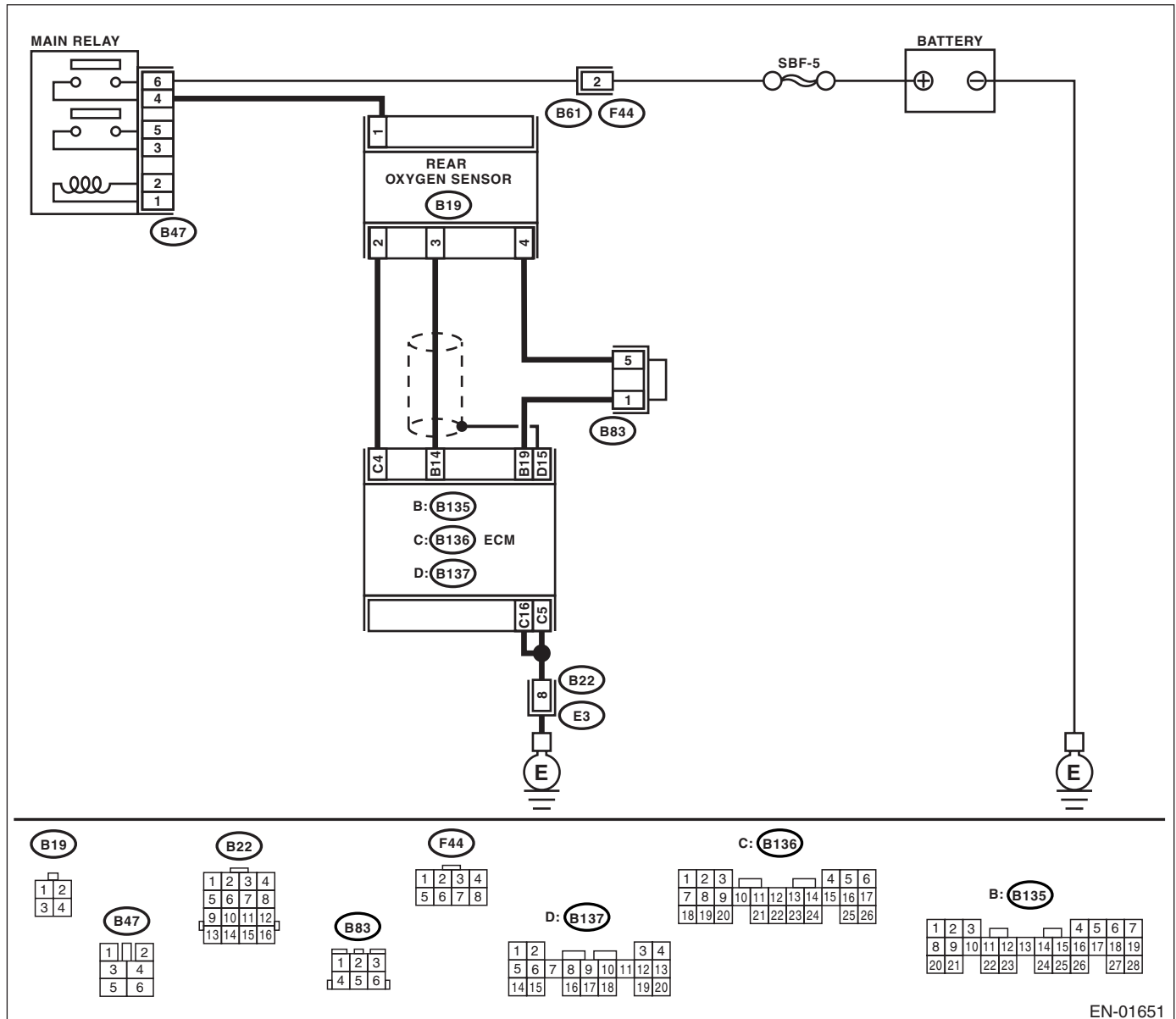

EN-01651

Diagnostic Procedure with Diagnostic Trouble Code (DTC)

ENGINE (DIAGNOSTICS)

Step	Check	Yes	No
1 CHECK ANY OTHER DTC ON DISPLAY.	Is any other DTC displayed?	Check DTC using "List of Diagnostic Trouble Code (DTC)". <Ref. to EN(H4SO)(diag)-71, List of Diagnostic Trouble Code (DTC).> NOTE: In this case, it is not necessary to inspect DTC P0139.	Replace the rear oxygen sensor. <Ref. to FU(H4SO)-42, Rear Oxygen Sensor.>

AE:DTC P0171 SYSTEM TOO LEAN (BANK 1)

Refer to DTC P0172 for diagnostic procedure. <Ref. to EN(H4SO)(diag)-146, DTC P0172 SYSTEM TOO RICH (BANK 1), Diagnostic Procedure with Diagnostic Trouble Code (DTC).>

Diagnostic Procedure with Diagnostic Trouble Code (DTC)

ENGINE (DIAGNOSTICS)

AF:DTC P0172 SYSTEM TOO RICH (BANK 1)

DTC DETECTING CONDITION:

- Two consecutive driving cycles with fault
- GENERAL DESCRIPTION <Ref. to GD(H4SO)-73, DTC P0172 SYSTEM TOO RICH (BANK 1), Diagnostic Trouble Code (DTC) Detecting Criteria.>

TROUBLE SYMPTOM:

- Erroneous idling
- Engine stalls.
- Poor driving performance

CAUTION:

After repair or replacement of faulty parts, conduct Clear Memory Mode <Ref. to EN(H4SO)(diag)-44, OPERATION, Clear Memory Mode.> and Inspection Mode <Ref. to EN(H4SO)(diag)-37, OPERATION, Inspection Mode.>.

Step	Check	Yes	No
1	CHECK EXHAUST SYSTEM.	Are there holes or loose bolts on exhaust system?	Repair exhaust system. Go to step 2.
2	CHECK AIR INTAKE SYSTEM.	Are there holes, loose bolts or disconnection of hose on air intake system?	Repair air intake system. Go to step 3.
3	CHECK PURGE CONTROL SOLENOID VALVE OR PRESSURE CONTROL SOLENOID VALVE.	Is the purge control solenoid valve or pressure control solenoid valve stuck?	Replace the purge control solenoid valve or pressure control solenoid valve. Go to step 4.
4	CHECK FUEL PRESSURE. Warning: • Place “NO FIRE” signs near the working area. • Be careful not to spill fuel on the floor. 1) Release fuel pressure. (1) Disconnect the connector from fuel pump relay. (2) Start the engine and run it until it stalls. (3) After the engine stalls, crank it for five more seconds. (4) Turn the ignition switch to OFF. 2) Connect the connector to fuel pump relay. 3) Disconnect the fuel delivery hose from fuel filter, and connect fuel pressure gauge. 4) Install the fuel filler cap. 5) Start the engine and idle while gear position is neutral. 6) Measure the fuel pressure while disconnecting pressure regulator vacuum hose from intake manifold. Warning: Before removing the fuel pressure gauge, release fuel pressure. NOTE: If fuel pressure does not increase, squeeze fuel return hose 2 to 3 times, then measure fuel pressure again.	Is the fuel pressure 284 — 314 kPa (2.9 — 3.2 kg/cm ² , 41 — 46 psi)?	Go to step 5. Repair the following items. Fuel pressure too high • Clogged fuel return line or bent hose Fuel pressure too low • Improper fuel pump discharge • Clogged fuel supply line

Diagnostic Procedure with Diagnostic Trouble Code (DTC)

ENGINE (DIAGNOSTICS)

Step	Check	Yes	No
<p>5 CHECK FUEL PRESSURE. After connecting the pressure regulator vacuum hose, measure fuel pressure.</p> <p>Warning: Before removing the fuel pressure gauge, release fuel pressure.</p> <p>NOTE:</p> <ul style="list-style-type: none"> • If fuel pressure does not increase, squeeze fuel return hose 2 to 3 times, then measure fuel pressure again. • If out of specification as measured at this step, check or replace pressure regulator and pressure regulator vacuum hose. 	<p>Is the fuel pressure 206 — 235 kPa (2.1 — 2.4 kg/cm², 30 — 34 psi)?</p>	<p>Go to step 6.</p>	<p>Repair the following items.</p> <p>Fuel pressure too high</p> <ul style="list-style-type: none"> • Faulty pressure regulator • Clogged fuel return line or bent hose <p>Fuel pressure too low</p> <ul style="list-style-type: none"> • Faulty pressure regulator • Improper fuel pump discharge • Clogged fuel supply line
<p>6 CHECK ENGINE COOLANT TEMPERATURE SENSOR.</p> <ol style="list-style-type: none"> 1) Start the engine and warm-up completely. 2) Read the data of engine coolant temperature sensor signal using Subaru Select Monitor or OBD-II general scan tool. <p>NOTE:</p> <ul style="list-style-type: none"> • Subaru Select Monitor <p>For detailed operation procedure, refer to the "READ CURRENT DATA FOR ENGINE". <Ref. to EN(H4SO)(diag)-30, Subaru Select Monitor.></p> <ul style="list-style-type: none"> • OBD-II general scan tool <p>For detailed operation procedures, refer to the OBD-II General Scan Tool Instruction Manual.</p>	<p>Is the engine coolant temperature 70 — 100°C (158 — 212°F)?</p>	<p>Go to step 7.</p>	<p>Replace the engine coolant temperature sensor. <Ref. to FU(H4SO)-24, Engine Coolant Temperature Sensor.></p>
<p>7 CHECK PRESSURE SENSOR SIGNAL.</p> <ol style="list-style-type: none"> 1) Start the engine and warm-up engine until coolant temperature is greater than 60°C (140°F). 2) Place the select lever in "N" or "P" range. 3) Turn the A/C switch to OFF. 4) Turn all accessory switches to OFF. 5) Read the data of pressure sensor signal using Subaru Select Monitor or OBD-II general scan tool. <p>NOTE:</p> <ul style="list-style-type: none"> • Subaru Select Monitor <p>For detailed operation procedure, refer to the "READ CURRENT DATA FOR ENGINE". <Ref. to EN(H4SO)(diag)-30, Subaru Select Monitor.></p> <ul style="list-style-type: none"> • OBD-II general scan tool <p>For detailed operation procedures, refer to the OBD-II General Scan Tool Instruction Manual.</p>	<p>Idling: Is the measured value 24.0 — 41.3 kPa (180 — 310 mmHg, 7.09 — 12.20 inHg), Ignition ON: Is the measured value 73.3 — 106.6 kPa (550 — 800 mmHg, 21.65 — 31.50 inHg)?</p>	<p>Contact SOA Service Center.</p> <p>NOTE: Inspection by DTM is required, because probable cause is deterioration of multiple parts.</p>	<p>Replace the Pressure sensor. <Ref. to FU(H4SO)-30, Manifold Absolute Pressure Sensor.></p>

Diagnostic Procedure with Diagnostic Trouble Code (DTC)

ENGINE (DIAGNOSTICS)

AG:DTC P0181 FUEL TEMPERATURE SENSOR "A" CIRCUIT RANGE/PERFORMANCE

DTC DETECTING CONDITION:

- Fault occurs in two consecutive driving cycles
- GENERAL DESCRIPTION <Ref. to GD(H4SO)-75, DTC P0181 FUEL TEMPERATURE SENSOR "A" CIRCUIT RANGE/PERFORMANCE, Diagnostic Trouble Code (DTC) Detecting Criteria.>

CAUTION:

After repair or replacement of faulty parts, conduct CLEAR MEMORY MODE <Ref. to EN(H4SO)(diag)-44, OPERATION, Clear Memory Mode.> and INSPECTION MODE <Ref. to EN(H4SO)(diag)-37, OPERATION, Inspection Mode.>.

WIRING DIAGRAM:

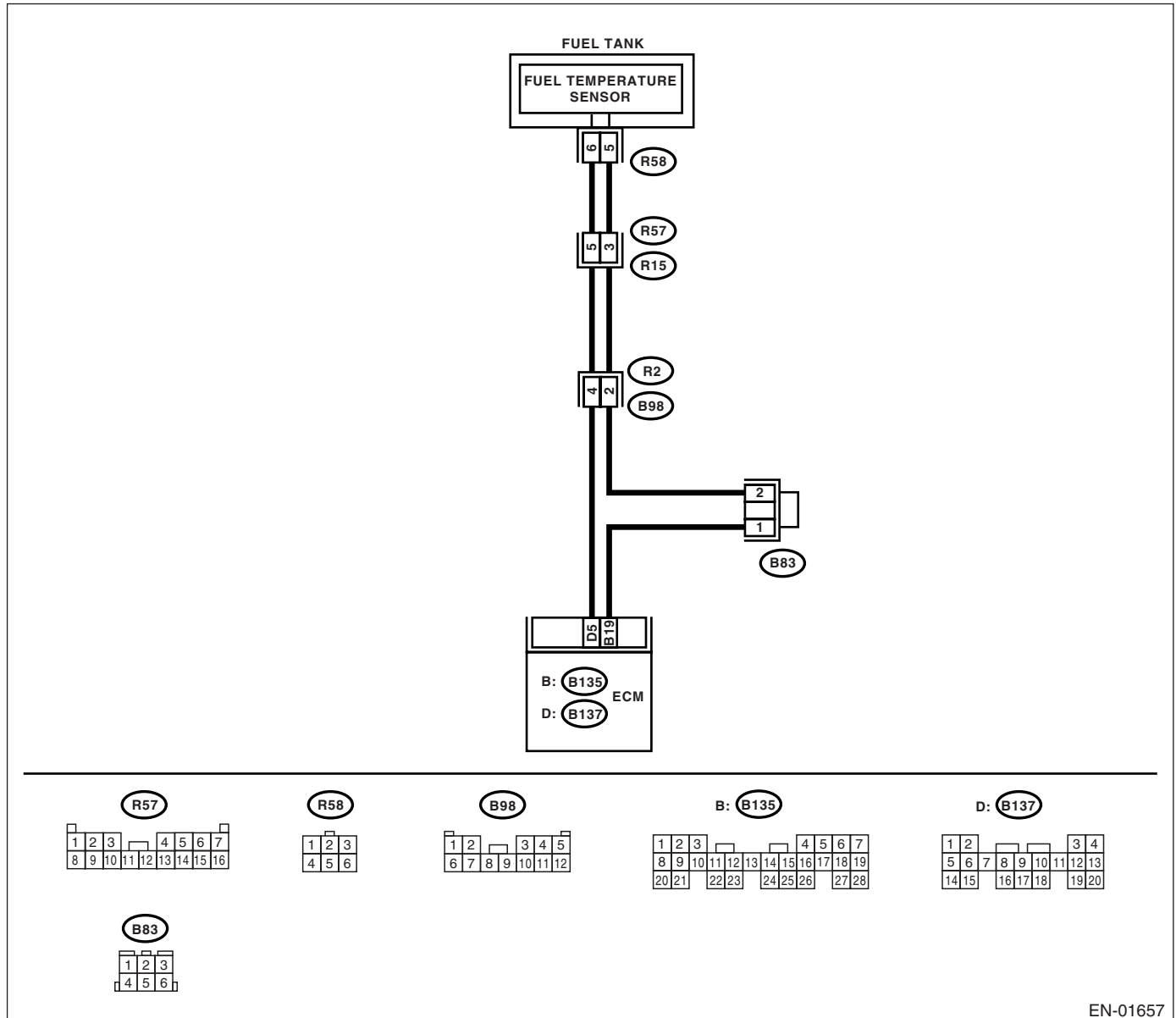

EN-01657

Diagnostic Procedure with Diagnostic Trouble Code (DTC)

ENGINE (DIAGNOSTICS)

Step	Check	Yes	No
1 CHECK FOR OTHER DTC ON DISPLAY.	Is any other DTC displayed?	Inspect DTC using "List of Diagnostic Trouble Code (DTC)". <Ref. to EN(H4SO)(diag)-71, List of Diagnostic Trouble Code (DTC).> NOTE: In this case, it is not necessary to inspect DTC P0181.	Replace the fuel temperature sensor. <Ref. to EC(H4SO)-8, Fuel Temperature Sensor.>

Diagnostic Procedure with Diagnostic Trouble Code (DTC)

ENGINE (DIAGNOSTICS)

AH:DTC P0182 FUEL TEMPERATURE SENSOR "A" CIRCUIT LOW INPUT

DTC DETECTING CONDITION:

- Immediately at fault recognition
- GENERAL DESCRIPTION <Ref. to GD(H4SO)-77, DTC P0182 FUEL TEMPERATURE SENSOR "A" CIRCUIT LOW INPUT, Diagnostic Trouble Code (DTC) Detecting Criteria.>

CAUTION:

After repair or replacement of faulty parts, conduct CLEAR MEMORY MODE <Ref. to EN(H4SO)(diag)-44, OPERATION, Clear Memory Mode.> and INSPECTION MODE <Ref. to EN(H4SO)(diag)-37, OPERATION, Inspection Mode.>.

WIRING DIAGRAM:

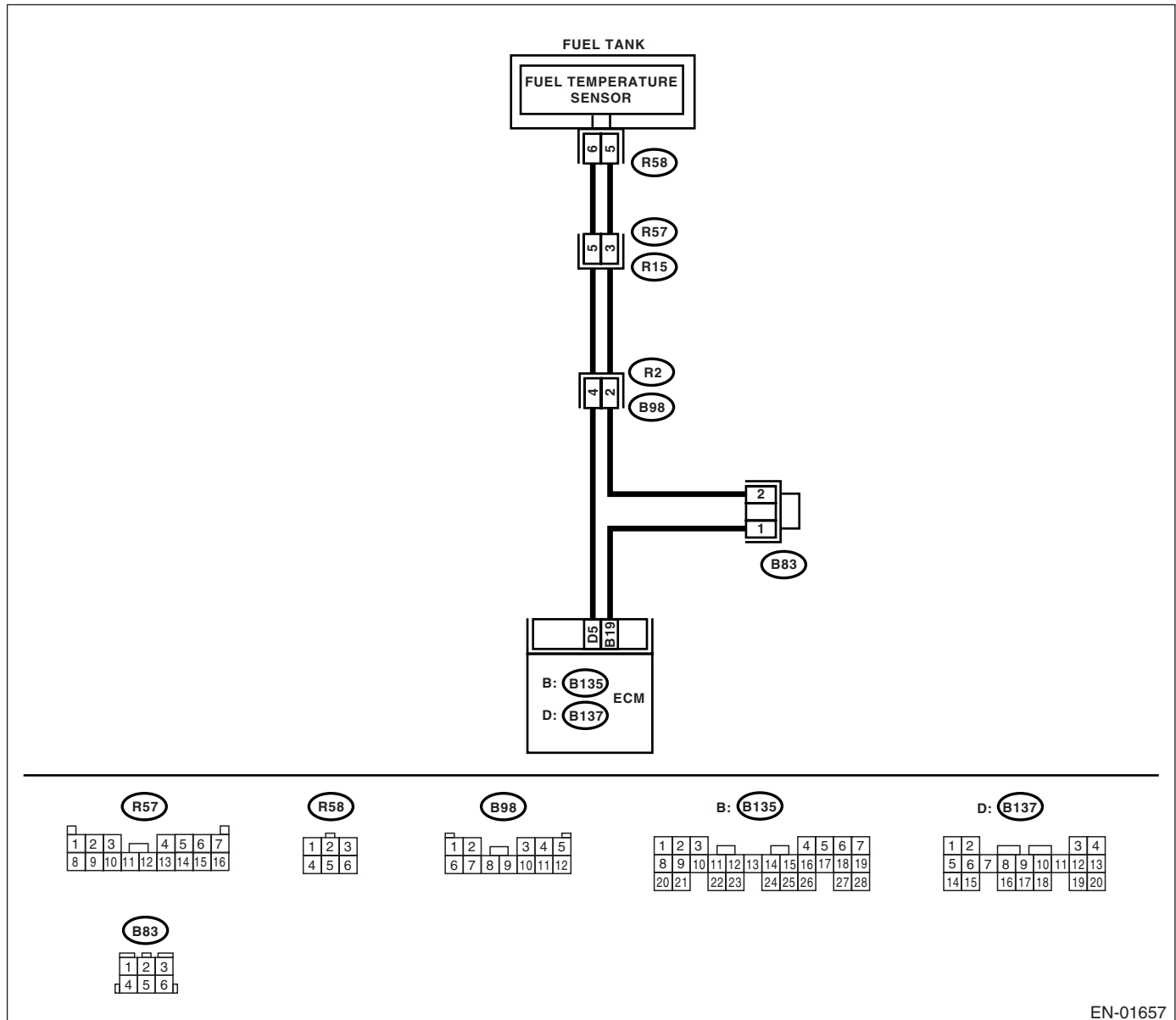

EN-01657

Diagnostic Procedure with Diagnostic Trouble Code (DTC)

ENGINE (DIAGNOSTICS)

Step	Check	Yes	No
<p>1</p> <p>CHECK CURRENT DATA.</p> <p>1) Start the engine.</p> <p>2) Read the data of fuel temperature sensor signal using Subaru Select Monitor or OBD-II general scan tool.</p> <p>NOTE:</p> <ul style="list-style-type: none"> • Subaru Select Monitor <p>For detailed operation procedures, refer to "READ CURRENT DATA FOR ENGINE". <Ref. to EN(H4SO)(diag)-30, Subaru Select Monitor.></p> <ul style="list-style-type: none"> • OBD-II general scan tool <p>For detailed operation procedures, refer to the OBD-II General Scan Tool Instruction Manual.</p>	<p>Is the fuel temperature 150°C (302°F)?</p>	<p>Go to step 2.</p>	<p>The malfunction indicator light may light up, however, the circuit is returned to the normal status at the moment.</p>
<p>2</p> <p>CHECK CURRENT DATA.</p> <p>1) Turn ignition switch to OFF.</p> <p>2) Remove the access hole lid.</p> <p>3) Disconnect the connector from fuel pump.</p> <p>4) Turn ignition switch to ON.</p> <p>5) Read the data of fuel temperature sensor signal using Subaru Select Monitor or OBD-II general scan tool.</p> <p>NOTE:</p> <ul style="list-style-type: none"> • Subaru Select Monitor <p>For detailed operation procedures, refer to "READ CURRENT DATA FOR ENGINE". <Ref. to EN(H4SO)(diag)-30, Subaru Select Monitor.></p> <ul style="list-style-type: none"> • OBD-II general scan tool <p>For detailed operation procedures, refer to the OBD-II General Scan Tool Instruction Manual.</p>	<p>Is the fuel temperature -40°C (-40°F)?</p>	<p>Replace the fuel temperature sensor. <Ref. to EC(H4SO)-8, Fuel Temperature Sensor.></p>	<p>Repair short circuit to ground in harness between fuel pump and ECM connector.</p>

Diagnostic Procedure with Diagnostic Trouble Code (DTC)

ENGINE (DIAGNOSTICS)

AI: DTC P0183 FUEL TEMPERATURE SENSOR "A" CIRCUIT HIGH INPUT

DTC DETECTING CONDITION:

- Immediately at fault recognition
- GENERAL DESCRIPTION <Ref. to GD(H4SO)-79, DTC P0183 FUEL TEMPERATURE SENSOR "A" CIRCUIT HIGH INPUT, Diagnostic Trouble Code (DTC) Detecting Criteria.>

CAUTION:

After repair or replacement of faulty parts, conduct CLEAR MEMORY MODE <Ref. to EN(H4SO)(diag)-44, OPERATION, Clear Memory Mode.> and INSPECTION MODE <Ref. to EN(H4SO)(diag)-37, OPERATION, Inspection Mode.>.

WIRING DIAGRAM:

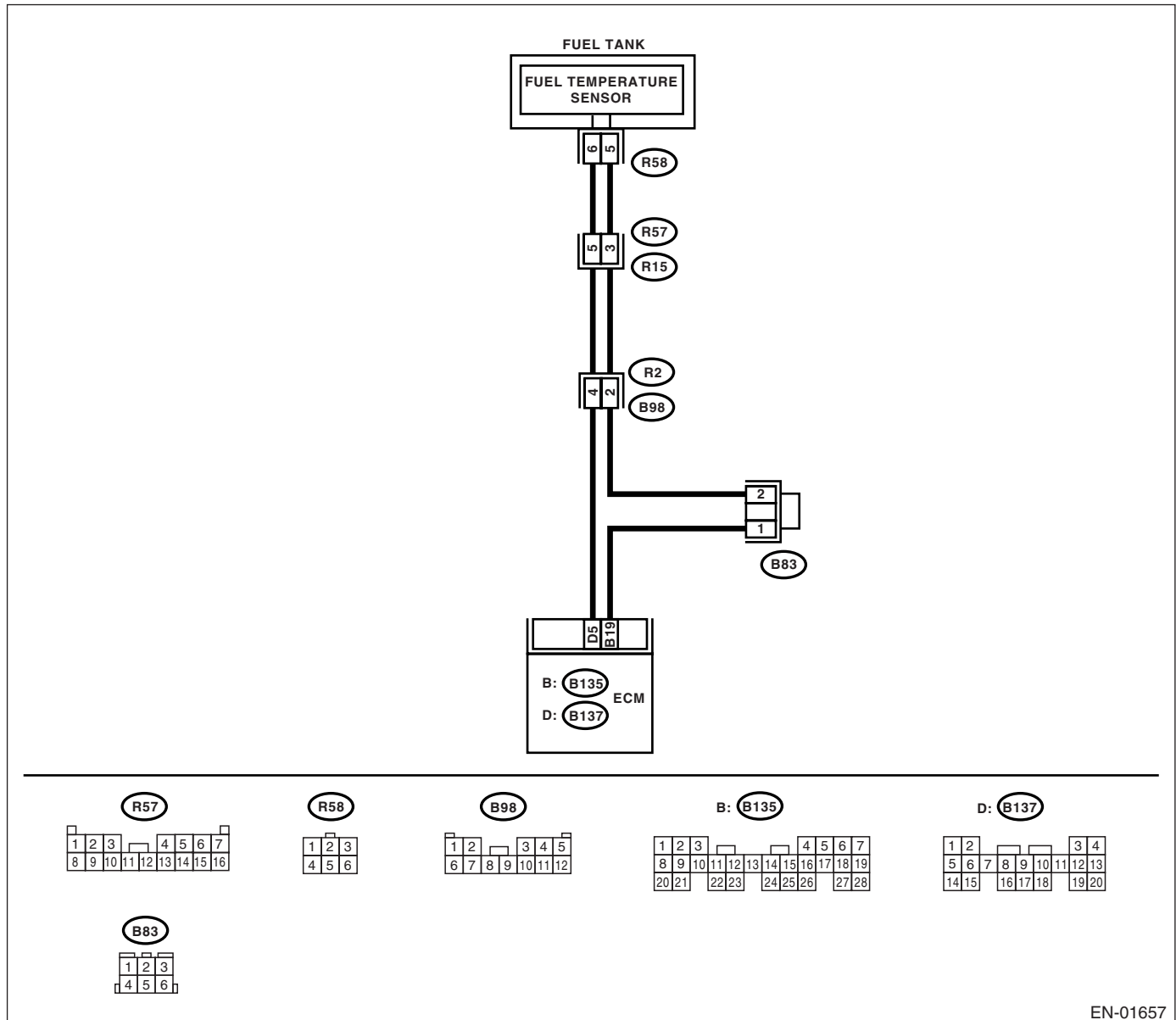

EN-01657

Diagnostic Procedure with Diagnostic Trouble Code (DTC)

ENGINE (DIAGNOSTICS)

Step	Check	Yes	No
1 CHECK CURRENT DATA. 1) Start the engine. 2) Read the data of fuel temperature sensor signal using Subaru Select Monitor or OBD-II general scan tool. NOTE: • Subaru Select Monitor For detailed operation procedures, refer to "READ CURRENT DATA FOR ENGINE". <Ref. to EN(H4SO)(diag)-30, Subaru Select Monitor.> • OBD-II general scan tool For detailed operation procedures, refer to the OBD-II General Scan Tool Instruction Manual.	Is the fuel temperature -40°C (-40°F)?	Go to step 2.	Repair poor contact. NOTE: In this case, repair the following: • Poor contact in fuel pump connector • Poor contact in ECM connector • Poor contact in coupling connector • Poor contact in joint connector
2 CHECK HARNESS BETWEEN FUEL TEMPERATURE SENSOR AND ECM CONNECTOR. 1) Turn ignition switch to OFF. 2) Remove the access hole lid. 3) Disconnect the connector from fuel pump. 4) Measure the voltage between fuel pump connector and chassis ground. Connector & terminal (R58) No. 6 (+) — Chassis ground (-):	Is the voltage more than 10 V?	Repair short circuit to battery in harness between ECM and fuel pump connector.	Go to step 3.
3 CHECK HARNESS BETWEEN FUEL TEMPERATURE SENSOR AND ECM CONNECTOR. 1) Turn ignition switch to ON. 2) Measure the voltage between fuel pump connector and chassis ground. Connector & terminal (R58) No. 6 (+) — Chassis ground (-):	Is the voltage more than 10 V?	Repair short circuit to battery in harness between ECM and fuel pump connector.	Go to step 4.
4 CHECK HARNESS BETWEEN FUEL TEMPERATURE SENSOR AND ECM CONNECTOR. Measure the voltage between fuel pump connector and chassis ground. Connector & terminal (R58) No. 6 (+) — Chassis ground (-):	Is the voltage more than 4 V?	Go to step 5.	Repair harness and connector. NOTE: In this case, repair the following: • Open circuit in harness between ECM and fuel pump connector • Poor contact in fuel pump connector • Poor contact in ECM connector • Poor contact in coupling connector

Diagnostic Procedure with Diagnostic Trouble Code (DTC)

ENGINE (DIAGNOSTICS)

Step	Check	Yes	No
5 CHECK HARNESS BETWEEN FUEL TEMPERATURE SENSOR AND ECM CONNECTOR. 1) Turn ignition switch to OFF. 2) Disconnect the connector from ECM. 3) Measure the resistance of harness between fuel pump connector and ECM. <i>Connector & terminal</i> <i>(R58) No. 5 — (B135) No. 19:</i>	Is the resistance less than 1 Ω ?	Replace the fuel temperature sensor. <Ref. to EC(H4SO)-8, Fuel Temperature Sensor.>	Repair harness and connector. NOTE: In this case, repair the following: <ul style="list-style-type: none"> • Open circuit in harness between ECM and fuel pump connector • Poor contact in fuel pump connector • Poor contact in ECM connector • Poor contact in coupling connector • Poor contact in joint connector

AJ:DTC P0301 CYLINDER 1 MISFIRE DETECTED

NOTE:

For the diagnostic procedure, refer to DTC P0304. <Ref. to EN(H4SO)(diag)-155, DTC P0304 CYLINDER 4 MISFIRE DETECTED, Diagnostic Procedure with Diagnostic Trouble Code (DTC).>

AK:DTC P0302 CYLINDER 2 MISFIRE DETECTED

NOTE:

For the diagnostic procedure, refer to DTC P0304. <Ref. to EN(H4SO)(diag)-155, DTC P0304 CYLINDER 4 MISFIRE DETECTED, Diagnostic Procedure with Diagnostic Trouble Code (DTC).>

AL:DTC P0303 CYLINDER 3 MISFIRE DETECTED

NOTE:

For the diagnostic procedure, refer to DTC P0304. <Ref. to EN(H4SO)(diag)-155, DTC P0304 CYLINDER 4 MISFIRE DETECTED, Diagnostic Procedure with Diagnostic Trouble Code (DTC).>

Diagnostic Procedure with Diagnostic Trouble Code (DTC)

ENGINE (DIAGNOSTICS)

AM:DTC P0304 CYLINDER 4 MISFIRE DETECTED

DTC DETECTING CONDITION:

- Two consecutive driving cycles with fault
- Immediately at fault recognition (A misfire which could damage catalyst occurs.)
- GENERAL DESCRIPTION <Ref. to GD(H4SO)-86, DTC P0304 CYLINDER 4 MISFIRE DETECTED, Diagnostic Trouble Code (DTC) Detecting Criteria.>

TROUBLE SYMPTOM:

- Engine stalls.
- Erroneous idling
- Rough driving

CAUTION:

After repair or replacement of faulty parts, conduct Clear Memory Mode <Ref. to EN(H4SO)(diag)-44, OPERATION, Clear Memory Mode.> and Inspection Mode <Ref. to EN(H4SO)(diag)-37, OPERATION, Inspection Mode.>.

WIRING DIAGRAM:

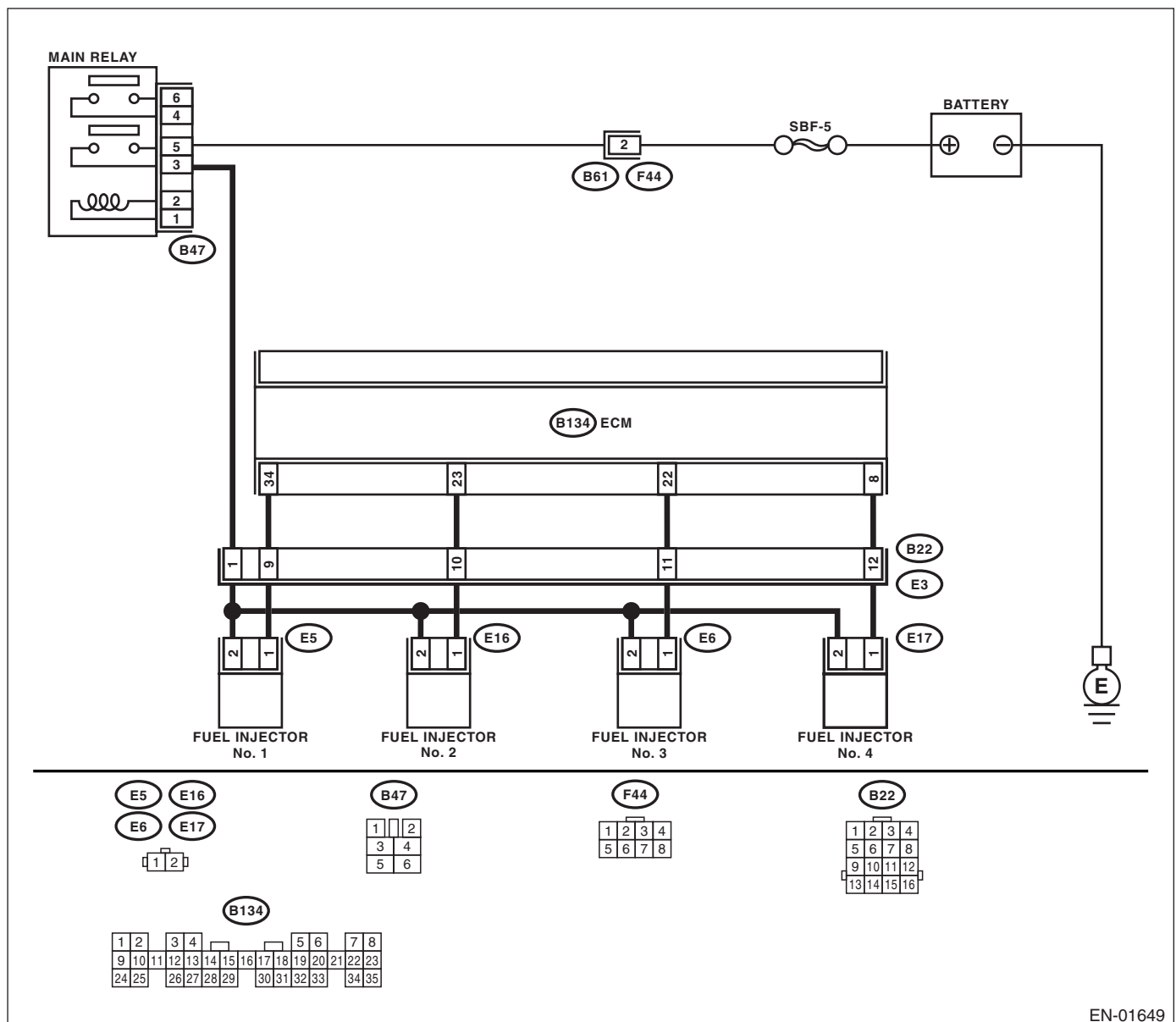

EN-01649

Diagnostic Procedure with Diagnostic Trouble Code (DTC)

ENGINE (DIAGNOSTICS)

Step	Check	Yes	No
1 CHECK ANY OTHER DTC ON DISPLAY.	Is any other DTC displayed?	Check DTC using "List of Diagnostic Trouble Code (DTC)". <Ref. to EN(H4SO)(diag)-71, List of Diagnostic Trouble Code (DTC).> NOTE: In this case, it is not necessary to inspect DTC P0301, P0302, P0303 and P0304.	Go to step 2.
2 CHECK OUTPUT SIGNAL FROM ECM. 1) Turn the ignition switch to ON. 2) Measure the voltage between ECM connector and chassis ground on faulty cylinders. Connector & terminal <i>#1 (B134) No. 34 (+) — Chassis ground (-):</i> <i>#2 (B134) No. 23 (+) — Chassis ground (-):</i> <i>#3 (B134) No. 22 (+) — Chassis ground (-):</i> <i>#4 (B134) No. 8 (+) — Chassis ground (-):</i>	Is the voltage more than 10 V?	Go to step 7.	Go to step 3.
3 CHECK HARNESS BETWEEN FUEL INJECTOR AND ECM CONNECTOR. 1) Turn the ignition switch to OFF. 2) Disconnect the connector from fuel injector on faulty cylinders. 3) Measure the resistance between ECM connector and engine ground on faulty cylinders. Connector & terminal <i>#1 (E5) No. 1 — Engine ground:</i> <i>#2 (E16) No. 1 — Engine ground:</i> <i>#3 (E6) No. 1 — Engine ground:</i> <i>#4 (E17) No. 1 — Engine ground:</i>	Is the resistance more than 1 MΩ?	Go to step 4.	Repair ground short circuit in harness between fuel injector and ECM connector.
4 CHECK HARNESS BETWEEN FUEL INJECTOR AND ECM CONNECTOR. Measure the resistance of harness connector between ECM connector and fuel injector on faulty cylinders. Connector & terminal <i>#1 (B134) No. 34 — (E5) No. 1:</i> <i>#2 (B134) No. 23 — (E16) No. 1:</i> <i>#3 (B134) No. 22 — (E6) No. 1:</i> <i>#4 (B134) No. 8 — (E17) No. 1:</i>	Is the resistance less than 1 Ω?	Go to step 5.	Repair harness and connector. NOTE: In this case, repair the following: <ul style="list-style-type: none"> • Open circuit in harness between ECM and fuel injector connector • Poor contact in coupling connector
5 CHECK FUEL INJECTOR. Measure the resistance between fuel injector terminals on faulty cylinder. Terminals <i>No. 1 — No. 2:</i>	Is the resistance 5 — 20 Ω?	Go to step 6.	Replace the faulty fuel injector. <Ref. to FU(H4SO)-34, Fuel Injector.>

Diagnostic Procedure with Diagnostic Trouble Code (DTC)

ENGINE (DIAGNOSTICS)

Step	Check	Yes	No
<p>6 CHECK POWER SUPPLY LINE. 1) Turn the ignition switch to ON. 2) Measure the voltage between fuel injector and engine ground on faulty cylinders. Connector & terminal <i>#1 (E5) No. 2 (+) — Engine ground (-):</i> <i>#2 (E16) No. 2 (+) — Engine ground (-):</i> <i>#3 (E6) No. 2 (+) — Engine ground (-):</i> <i>#4 (E17) No. 2 (+) — Engine ground (-):</i></p>	Is the voltage more than 10 V?	Repair poor contact in all connectors in fuel injector circuit.	Repair harness and connector. NOTE: In this case, repair the following: <ul style="list-style-type: none"> • Open circuit in harness between main relay and fuel injector connector on faulty cylinders • Poor contact in coupling connector • Poor contact in main relay connector • Poor contact in fuel injector connector on faulty cylinders
<p>7 CHECK HARNESS BETWEEN FUEL INJECTOR AND ECM CONNECTOR. 1) Turn the ignition switch to OFF. 2) Disconnect the connector from fuel injector on faulty cylinder. 3) Turn the ignition switch to ON. 4) Measure the voltage between ECM connector and chassis ground on faulty cylinders. Connector & terminal <i>#1 (B134) No. 34 (+) — Chassis ground (-):</i> <i>#2 (B134) No. 23 (+) — Chassis ground (-):</i> <i>#3 (B134) No. 22 (+) — Chassis ground (-):</i> <i>#4 (B134) No. 8 (+) — Chassis ground (-):</i></p>	Is the voltage more than 10 V?	Repair battery short circuit in harness between ECM and fuel injector. After repair, replace the ECM. <Ref. to FU(H4SO)-44, Engine Control Module (ECM).>	Go to step 8.
<p>8 CHECK FUEL INJECTOR. 1) Turn the ignition switch to OFF. 2) Measure the resistance between fuel injector terminals on faulty cylinder. Terminals <i>No. 1 — No. 2:</i></p>	Is the resistance less than 1 Ω ?	Replace the faulty fuel injector <Ref. to FU(H4SO)-34, Fuel Injector.> and ECM <Ref. to FU(H4SO)-44, Engine Control Module (ECM).>	Go to step 9.
<p>9 CHECK INSTALLATION OF CAMSHAFT POSITION SENSOR/CRANKSHAFT POSITION SENSOR.</p>	Is the camshaft position sensor or crankshaft position sensor loosely installed?	Tighten camshaft position sensor or crankshaft position sensor.	Go to step 10.
<p>10 CHECK CRANKSHAFT SPROCKET. Remove the timing belt cover.</p>	Is the crankshaft sprocket rusted or does it have broken teeth?	Replace the crankshaft sprocket. <Ref. to ME(H4SO)-51, Crankshaft Sprocket.>	Go to step 11.
<p>11 CHECK INSTALLATION CONDITION OF TIMING BELT. Turn the crankshaft using ST, and align alignment mark on crankshaft sprocket with alignment mark on cylinder block. ST 499987500 CRANKSHAFT SOCKET</p>	Is the timing belt dislocated from its proper position?	Repair installation condition of timing belt. <Ref. to ME(H4SO)-44, Timing Belt Assembly.>	Go to step 12.

Diagnostic Procedure with Diagnostic Trouble Code (DTC)

ENGINE (DIAGNOSTICS)

Step	Check	Yes	No
12 CHECK FUEL LEVEL.	Is the fuel meter indication higher than the "Lower" level?	Go to step 13 .	Replenish fuel so fuel meter indication is higher than the "Lower" level. After replenishing fuel, Go to step 13 .
13 CHECK STATUS OF MALFUNCTION INDICATOR LIGHT. 1) Clear the memory using Subaru Select Monitor. <Ref. to EN(H4SO)(diag)-44, Clear Memory Mode.> 2) Start the engine, and drive the vehicle more than 10 minutes.	Does the malfunction indicator light illuminate or blink?	Go to step 16 .	Go to step 14 .
14 CHECK CAUSE OF MISFIRE DIAGNOSED.	Was the cause of misfire identified when the engine is running? Ex. Disconnection of spark plug cord.	Finish diagnostics operation, if the engine has no abnormality.	Go to step 15 .
15 CHECK FOR POOR CONTACT.	Is there poor contact in the ignition coil, fuel injector, ECM and coupling connector?	Repair poor contact.	Contact your SOA Service Center after checking followings. NOTE: In this case, check the following: <ul style="list-style-type: none"> • Condition of fuel • Fuel additive used or not • Visually check spark plug • Visually check spark plug cord • Condition of engine oil
16 CHECK AIR INTAKE SYSTEM.	Is there a fault in air intake system?	Repair air intake system. NOTE: Check the following items: <ul style="list-style-type: none"> • Are there air leaks or air suction caused by loose or dislocated nuts and bolts? • Are there cracks or any disconnection of hoses? 	Go to step 17 .

Diagnostic Procedure with Diagnostic Trouble Code (DTC)

ENGINE (DIAGNOSTICS)

Step	Check	Yes	No
17 CHECK MISFIRE SYMPTOM. 1) Turn the ignition switch to ON. 2) Read the DTC. NOTE: • Subaru Select Monitor For detailed operation procedures, refer to "READ CURRENT DATA FOR ENGINE". <Ref. to EN(H4SO)(diag)-30, Subaru Select Monitor.> • OBD-II general scan tool For detailed operation procedures, refer to the OBD-II General Scan Tool Operation Manual. NOTE: Perform diagnosis according to the items listed below.	Does the Subaru Select Monitor or OBD-II general scan tool display only one DTC?	Go to step 22 .	Go to step 18 .
18 CHECK DTC ON DISPLAY. Is any other DTC displayed?	Does the Subaru Select Monitor or OBD-II general scan tool indicate DTC P0301 and P0302?	Go to step 23 .	Go to step 19 .
19 CHECK DTC ON DISPLAY. Is any other DTC displayed?	Does the Subaru Select Monitor or OBD-II general scan tool indicate DTC P0303 and P0304?	Go to step 24 .	Go to step 20 .
20 CHECK DTC ON DISPLAY. Is any other DTC displayed?	Does the Subaru Select Monitor or OBD-II general scan tool indicate DTC P0301 and P0303?	Go to step 25 .	Go to step 21 .
21 CHECK DTC ON DISPLAY. Is any other DTC displayed?	Does the Subaru Select Monitor or OBD-II general scan tool indicate DTC P0302 and P0304?	Go to step 26 .	Go to step 27 .
22 ONLY ONE CYLINDER	Is there a fault in that cylinder?	Repair or replace faulty parts. NOTE: Check the following items. • Spark plug • Spark plug cord • Fuel injector • Compression ratio	Go to DTC P0171. <Ref. to EN(H4SO)(diag)-145, DTC P0171 SYSTEM TOO LEAN (BANK 1), Diagnostic Procedure with Diagnostic Trouble Code (DTC).>

Diagnostic Procedure with Diagnostic Trouble Code (DTC)

ENGINE (DIAGNOSTICS)

Step	Check	Yes	No
23 GROUP OF #1 AND #2 CYLINDERS	Are there faults in #1 and #2 cylinders?	Repair or replace faulty parts. NOTE: • Check the following items. <ul style="list-style-type: none"> • Spark plugs • Fuel injectors • Ignition coil • Compression ratio • If no abnormal is discovered, check for "IGNITION CONTROL SYSTEM" of #1 and #2 cylinders side. <Ref. to EN(H4SO)(diag)-63, IGNITION CONTROL SYSTEM, Diagnostics for Engine Starting Failure.>	Go to DTC P0171. <Ref. to EN(H4SO)(diag)-145, DTC P0171 SYSTEM TOO LEAN (BANK 1), Diagnostic Procedure with Diagnostic Trouble Code (DTC).>
24 GROUP OF #3 AND #4 CYLINDERS	Are there faults in #3 and #4 cylinders?	Repair or replace faulty parts. NOTE: • Check the following items. <ul style="list-style-type: none"> • Spark plugs • Fuel injectors • Ignition coil • If no abnormal is discovered, check for "IGNITION CONTROL SYSTEM" of #3 and #4 cylinders side. <Ref. to EN(H4SO)(diag)-63, IGNITION CONTROL SYSTEM, Diagnostics for Engine Starting Failure.>	Go to DTC P0171. <Ref. to EN(H4SO)(diag)-145, DTC P0171 SYSTEM TOO LEAN (BANK 1), Diagnostic Procedure with Diagnostic Trouble Code (DTC).>
25 GROUP OF #1 AND #3 CYLINDERS	Are there faults in #1 and #3 cylinders?	Repair or replace faulty parts. NOTE: Check the following items. <ul style="list-style-type: none"> • Spark plugs • Fuel injectors • Skipping timing belt teeth 	Go to DTC P0171. <Ref. to EN(H4SO)(diag)-145, DTC P0171 SYSTEM TOO LEAN (BANK 1), Diagnostic Procedure with Diagnostic Trouble Code (DTC).>

Diagnostic Procedure with Diagnostic Trouble Code (DTC)

ENGINE (DIAGNOSTICS)

Step	Check	Yes	No
26 GROUP OF #2 AND #4 CYLINDERS	Are there faults in #2 and #4 cylinders?	Repair or replace faulty parts. NOTE: Check the following items. <ul style="list-style-type: none">• Spark plugs• Fuel injectors• Compression ratio• Skipping timing belt teeth	Go to DTC P0171. <Ref. to EN(H4SO)(diag)-145, DTC P0171 SYSTEM TOO LEAN (BANK 1), Diagnostic Procedure with Diagnostic Trouble Code (DTC).>
27 CYLINDER AT RANDOM	Is the engine idle rough?	Go to DTC P0171. <Ref. to EN(H4SO)(diag)-145, DTC P0171 SYSTEM TOO LEAN (BANK 1), Diagnostic Procedure with Diagnostic Trouble Code (DTC).>	Repair or replace faulty parts. NOTE: Check the following items. <ul style="list-style-type: none">• Spark plugs• Fuel injectors• Compression ratio

Diagnostic Procedure with Diagnostic Trouble Code (DTC)

ENGINE (DIAGNOSTICS)

AN:DTC P0327 KNOCK SENSOR 1 CIRCUIT LOW INPUT (BANK 1 OR SINGLE SENSOR)

DTC DETECTING CONDITION:

- Immediately at fault recognition
- GENERAL DESCRIPTION <Ref. to GD(H4SO)-87, DTC P0327 KNOCK SENSOR 1 CIRCUIT LOW INPUT (BANK 1 OR SINGLE SENSOR), Diagnostic Trouble Code (DTC) Detecting Criteria.>

TROUBLE SYMPTOM:

- Poor driving performance
- Knocking occurs.

CAUTION:

After repair or replacement of faulty parts, conduct Clear Memory Mode <Ref. to EN(H4SO)(diag)-44, OPERATION, Clear Memory Mode.> and Inspection Mode <Ref. to EN(H4SO)(diag)-37, OPERATION, Inspection Mode.>.

WIRING DIAGRAM:

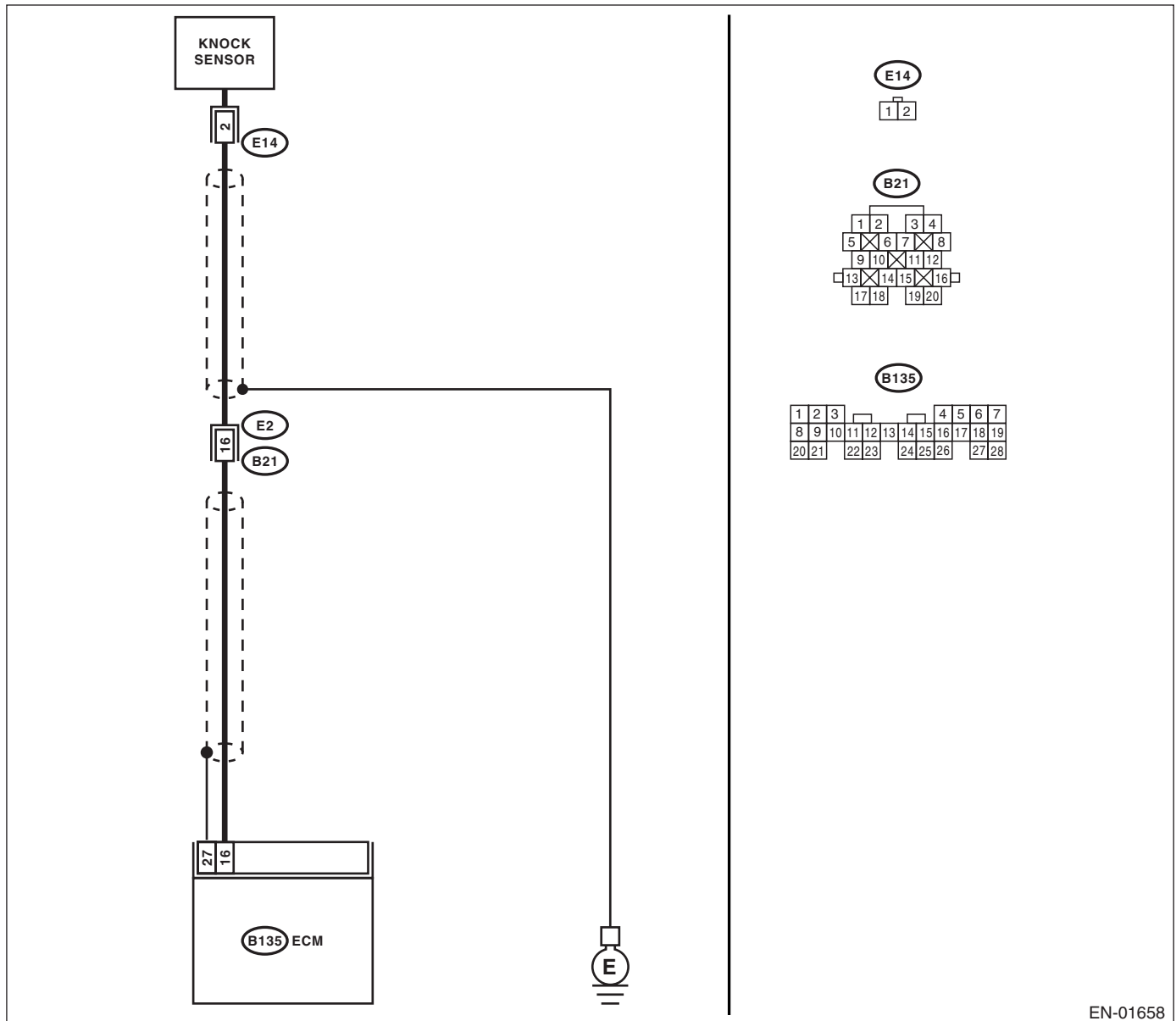

EN-01658

Diagnostic Procedure with Diagnostic Trouble Code (DTC)

ENGINE (DIAGNOSTICS)

Step	Check	Yes	No
<p>1</p> <p>CHECK HARNESS BETWEEN KNOCK SENSOR AND ECM CONNECTOR.</p> <p>1) Turn the ignition switch to OFF. 2) Disconnect the connector from ECM. 3) Measure the resistance between ECM harness connector and chassis ground.</p> <p>Connector & terminal (B135) No. 16 — Chassis ground:</p>	<p>Is the resistance more than 700 kΩ?</p>	<p>Go to step 2.</p>	<p>Repair harness and connector.</p> <p>NOTE: In this case, repair the following:</p> <ul style="list-style-type: none"> • Open circuit in harness between knock sensor and ECM connector • Poor contact in knock sensor connector • Poor contact in coupling connector
<p>2</p> <p>CHECK KNOCK SENSOR.</p> <p>1) Disconnect the connector from knock sensor. 2) Measure the resistance between knock sensor connector terminal and engine ground.</p> <p>Terminals No. 2 — Engine ground:</p>	<p>Is the resistance more than 700 kΩ?</p>	<p>Go to step 3.</p>	<p>Repair harness and connector.</p> <p>NOTE: In this case, repair the following:</p> <ul style="list-style-type: none"> • Poor contact in knock sensor connector
<p>3</p> <p>CHECK CONDITION OF KNOCK SENSOR INSTALLATION.</p>	<p>Is the knock sensor installation bolt tightened securely?</p>	<p>Replace the knock sensor. <Ref. to FU(H4SO)-27, Knock Sensor.></p>	<p>Tighten knock sensor installation bolt securely.</p>

Diagnostic Procedure with Diagnostic Trouble Code (DTC)

ENGINE (DIAGNOSTICS)

AO:DTC P0328 KNOCK SENSOR 1 CIRCUIT HIGH INPUT (BANK 1 OR SINGLE SENSOR)

DTC DETECTING CONDITION:

- Immediately at fault recognition
- GENERAL DESCRIPTION <Ref. to GD(H4SO)-89, DTC P0328 KNOCK SENSOR 1 CIRCUIT HIGH INPUT (BANK 1 OR SINGLE SENSOR), Diagnostic Trouble Code (DTC) Detecting Criteria.>

TROUBLE SYMPTOM:

- Poor driving performance
- Knocking occurs.

CAUTION:

After repair or replacement of faulty parts, conduct Clear Memory Mode <Ref. to EN(H4SO)(diag)-44, OPERATION, Clear Memory Mode.> and Inspection Mode <Ref. to EN(H4SO)(diag)-37, OPERATION, Inspection Mode.>.

WIRING DIAGRAM:

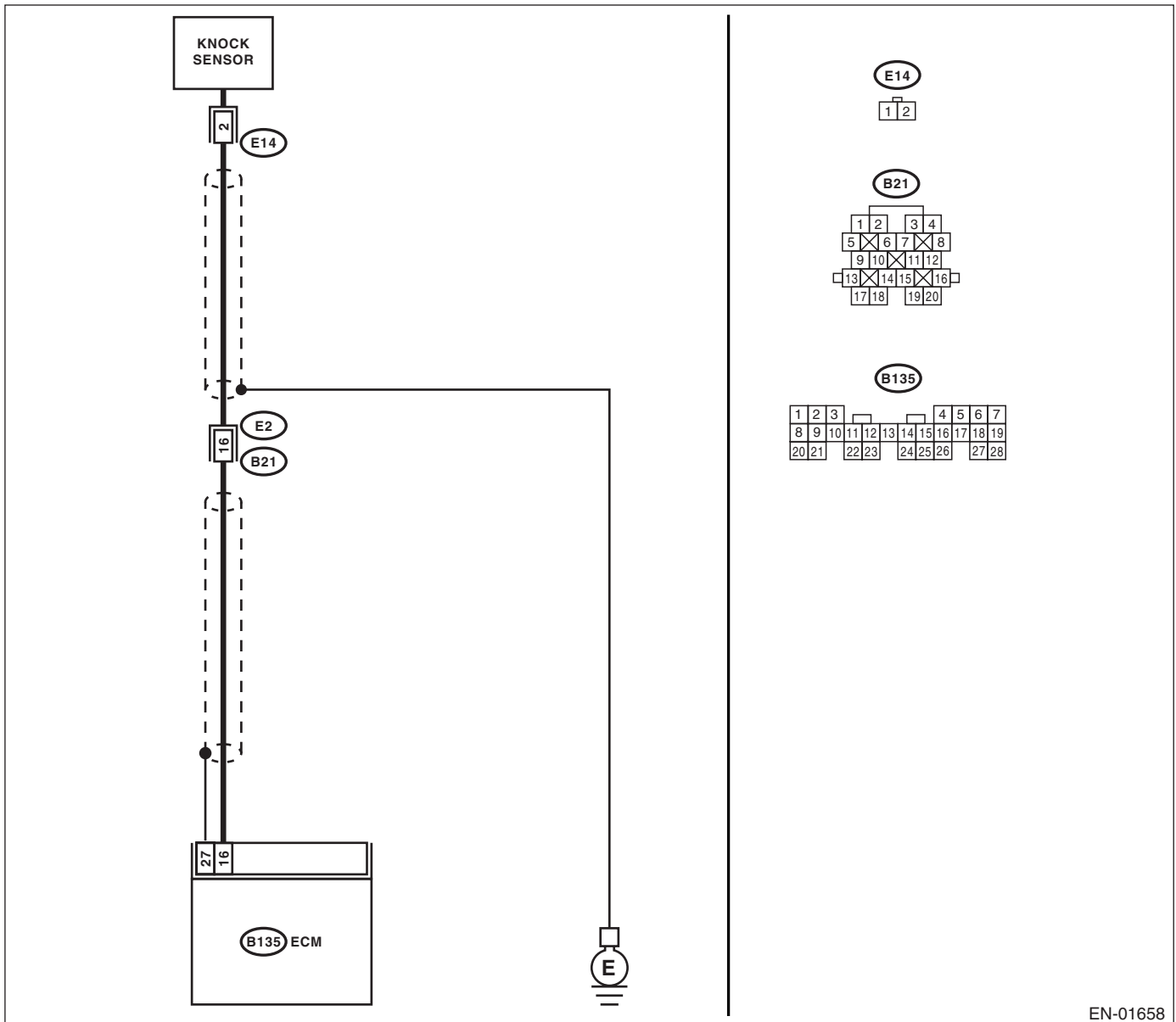

EN-01658

Diagnostic Procedure with Diagnostic Trouble Code (DTC)

ENGINE (DIAGNOSTICS)

Step	Check	Yes	No
1 CHECK HARNESS BETWEEN KNOCK SENSOR AND ECM CONNECTOR. Measure the resistance of harness between ECM connector and chassis ground. <i>Connector & terminal</i> <i>(B135) No. 16 — Chassis ground:</i>	Is the resistance less than 400 kΩ?	Go to step 2.	Go to step 3.
2 CHECK KNOCK SENSOR. 1) Disconnect the connector from knock sensor. 2) Measure the resistance between knock sensor connector terminal and engine ground. <i>Terminals</i> <i>No. 2 — Engine ground:</i>	Is the resistance less than 400 kΩ?	Replace the knock sensor. <Ref. to FU(H4SO)-27, Knock Sensor.>	Repair ground short circuit in harness between knock sensor connector and ECM connector. NOTE: The harness between both connectors is shielded. Repair short circuit of harness together with shield.
3 CHECK INPUT SIGNAL FOR ECM. 1) Connect the connectors to ECM and knock sensor. 2) Turn the ignition switch to ON. 3) Measure the voltage between ECM and chassis ground. <i>Connector & terminal</i> <i>(B135) No. 16 (+) — Chassis ground (-):</i>	Is the voltage more than 2 V?	Even if malfunction indicator light lights up, the circuit has returned to a normal condition at this time. (However, the possibility of poor contact still remains.) NOTE: In this case, repair the following: <ul style="list-style-type: none"> • Poor contact in knock sensor connector • Poor contact in ECM connector • Poor contact in coupling connector 	Repair poor contact in ECM connector.

Diagnostic Procedure with Diagnostic Trouble Code (DTC)

ENGINE (DIAGNOSTICS)

AP:DTC P0335 CRANKSHAFT POSITION SENSOR "A" CIRCUIT

DTC DETECTING CONDITION:

- Immediately at fault recognition
- GENERAL DESCRIPTION <Ref. to GD(H4SO)-91, DTC P0335 CRANKSHAFT POSITION SENSOR "A" CIRCUIT, Diagnostic Trouble Code (DTC) Detecting Criteria.>

TROUBLE SYMPTOM:

- Engine stalls.
- Failure of engine to start

CAUTION:

After repair or replacement of faulty parts, conduct Clear Memory Mode <Ref. to EN(H4SO)(diag)-44, OPERATION, Clear Memory Mode.> and Inspection Mode <Ref. to EN(H4SO)(diag)-37, OPERATION, Inspection Mode.>.

WIRING DIAGRAM:

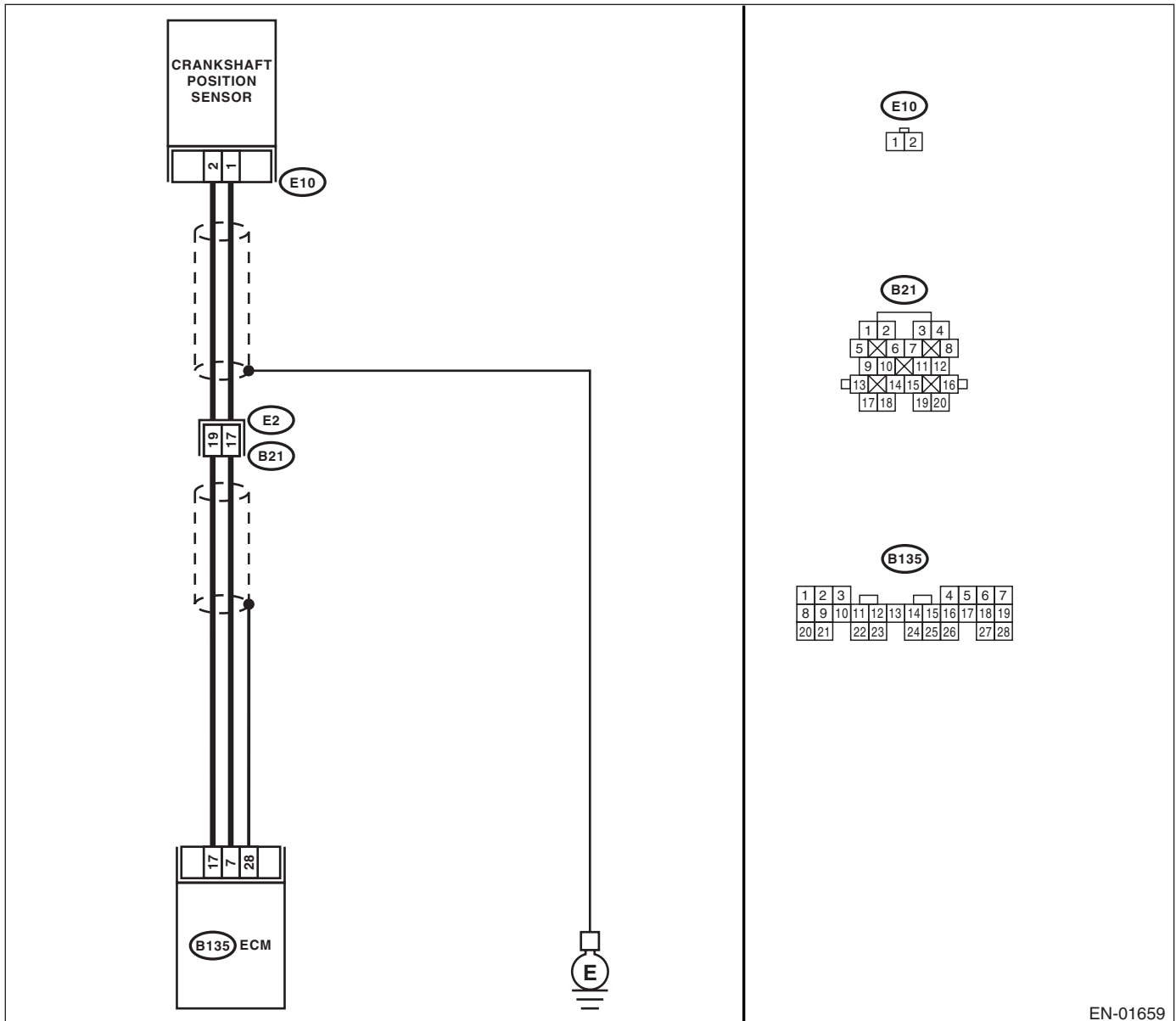

EN-01659

Diagnostic Procedure with Diagnostic Trouble Code (DTC)

ENGINE (DIAGNOSTICS)

Step	Check	Yes	No
<p>1</p> <p>CHECK HARNESS BETWEEN CRANKSHAFT POSITION SENSOR AND ECM CONNECTOR.</p> <p>1) Turn the ignition switch to OFF. 2) Disconnect the connector from crankshaft position sensor. 3) Measure the resistance of harness between crankshaft position sensor connector and engine ground.</p> <p>Connector & terminal (E10) No. 1 — Engine ground:</p>	<p>Is the resistance more than 100 kΩ?</p>	<p>Repair harness and connector.</p> <p>NOTE: In this case, repair the following:</p> <ul style="list-style-type: none"> • Open circuit in harness between crankshaft position sensor and ECM connector • Poor contact in ECM connector • Poor contact in coupling connector 	<p>Go to step 2.</p>
<p>2</p> <p>CHECK HARNESS BETWEEN CRANKSHAFT POSITION SENSOR AND ECM CONNECTOR.</p> <p>Measure the resistance of harness between crankshaft position sensor connector and engine ground.</p> <p>Connector & terminal (E10) No. 1 — Engine ground:</p>	<p>Is the resistance less than 10 Ω?</p>	<p>Repair ground short circuit in harness between crankshaft position sensor and ECM connector.</p> <p>NOTE: The harness between both connectors are shielded. Repair ground short circuit in harness together with shield.</p>	<p>Go to step 3.</p>
<p>3</p> <p>CHECK HARNESS BETWEEN CRANKSHAFT POSITION SENSOR AND ECM CONNECTOR.</p> <p>Measure the resistance of harness between crankshaft position sensor connector and engine ground.</p> <p>Connector & terminal (E10) No. 2 — Engine ground:</p>	<p>Is the resistance less than 5 Ω?</p>	<p>Go to step 4.</p>	<p>Repair harness and connector.</p> <p>NOTE: In this case, repair the following:</p> <ul style="list-style-type: none"> • Open circuit in harness between crankshaft position sensor and ECM connector • Poor contact in ECM connector • Poor contact in coupling connector
<p>4</p> <p>CHECK CONDITION OF CRANKSHAFT POSITION SENSOR.</p>	<p>Is the crankshaft position sensor installation bolt tightened securely?</p>	<p>Go to step 5.</p>	<p>Tighten crankshaft position sensor installation bolt securely.</p>
<p>5</p> <p>CHECK CRANKSHAFT POSITION SENSOR.</p> <p>1) Remove the crankshaft position sensor. 2) Measure the resistance between connector terminals of crankshaft position sensor.</p> <p>Terminals No. 1 — No. 2:</p>	<p>Is the resistance 1 — 4 kΩ?</p>	<p>Repair poor contact in crankshaft position sensor connector.</p>	<p>Replace the crankshaft position sensor. <Ref. to FU(H4SO)-25, Crankshaft Position Sensor.></p>

Diagnostic Procedure with Diagnostic Trouble Code (DTC)

ENGINE (DIAGNOSTICS)

AQ:DTC P0336 CRANKSHAFT POSITION SENSOR "A" CIRCUIT RANGE/PERFORMANCE

DTC DETECTING CONDITION:

- Immediately at fault recognition
- GENERAL DESCRIPTION <Ref. to GD(H4SO)-93, DTC P0336 CRANKSHAFT POSITION SENSOR "A" CIRCUIT RANGE/PERFORMANCE, Diagnostic Trouble Code (DTC) Detecting Criteria.>

TROUBLE SYMPTOM:

- Engine stalls.
- Failure of engine to start

CAUTION:

After repair or replacement of faulty parts, conduct Clear Memory Mode <Ref. to EN(H4SO)(diag)-44, OPERATION, Clear Memory Mode.> and Inspection Mode <Ref. to EN(H4SO)(diag)-37, OPERATION, Inspection Mode.>.

WIRING DIAGRAM:

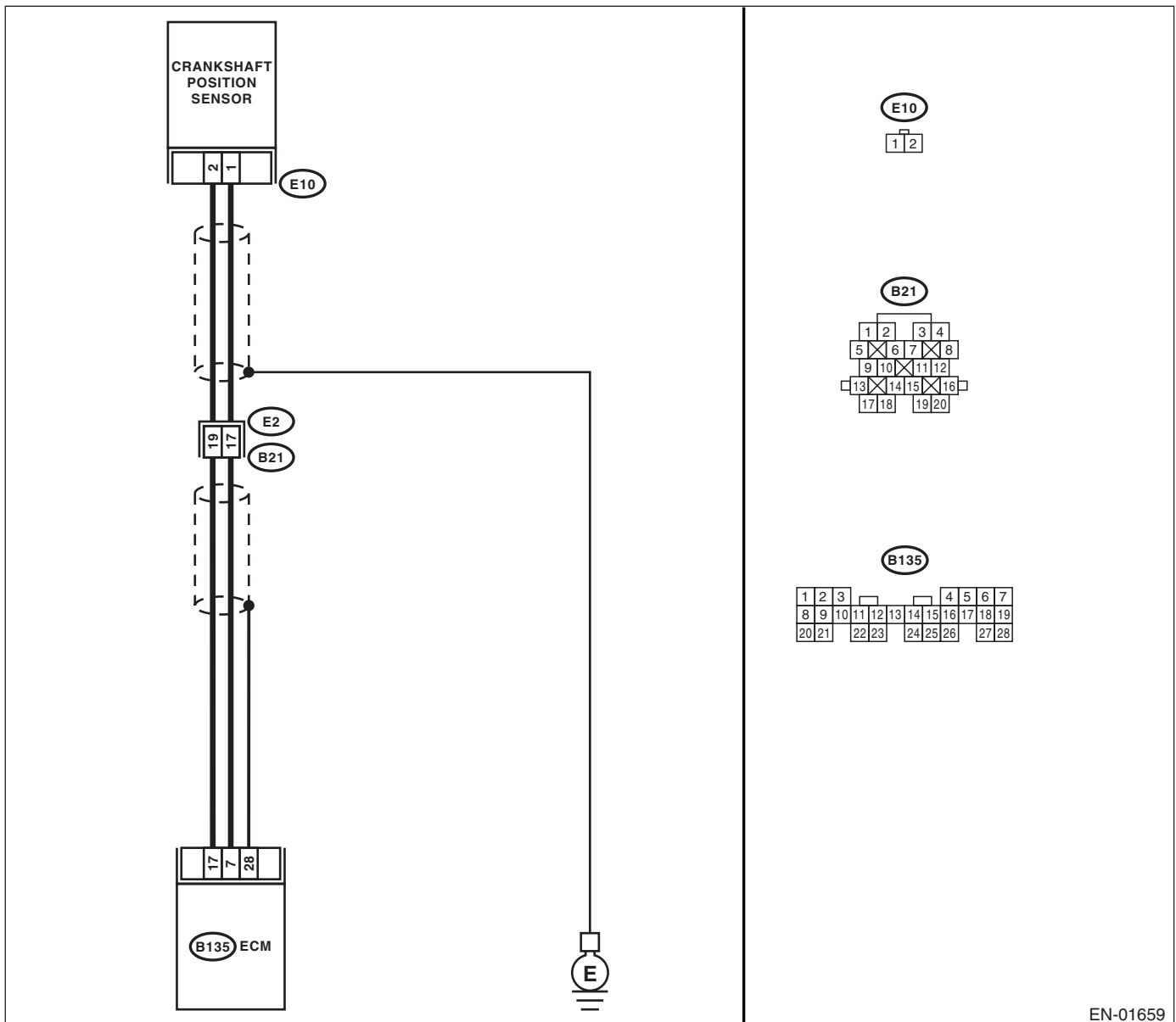

EN-01659

Diagnostic Procedure with Diagnostic Trouble Code (DTC)

ENGINE (DIAGNOSTICS)

	Step	Check	Yes	No
1	CHECK ANY OTHER DTC ON DISPLAY.	Is any other DTC displayed?	Inspect DTC using "List of Diagnostic Trouble Code (DTC)". <Ref. to EN(H4SO)(diag)-71, List of Diagnostic Trouble Code (DTC).>	Go to step 2.
2	CHECK CONDITION OF CRANKSHAFT POSITION SENSOR. Turn the ignition switch to OFF.	Is the crankshaft position sensor installation bolt tightened securely?	Go to step 3.	Tighten crankshaft position sensor installation bolt securely.
3	CHECK CRANKSHAFT SPROCKET. Remove the timing belt cover.	Are crankshaft sprocket teeth cracked or damaged?	Replace the crankshaft sprocket. <Ref. to ME(H4SO)-51, Crankshaft Sprocket.>	Go to step 4.
4	CHECK INSTALLATION CONDITION OF TIMING BELT. Turn the crankshaft using ST, and align alignment mark on crankshaft sprocket with alignment mark on cylinder block. ST 499987500 CRANKSHAFT SOCKET	Is the timing belt dislocated from its proper position?	Repair installation condition of timing belt. <Ref. to ME(H4SO)-44, Timing Belt Assembly.>	Replace the crankshaft position sensor. <Ref. to FU(H4SO)-25, Crankshaft Position Sensor.>

Diagnostic Procedure with Diagnostic Trouble Code (DTC)

ENGINE (DIAGNOSTICS)

AR:DTC P0340 CAMSHAFT POSITION SENSOR "A" CIRCUIT (BANK 1 OR SINGLE SENSOR)

DTC DETECTING CONDITION:

- Immediately at fault recognition
- GENERAL DESCRIPTION <Ref. to GD(H4SO)-96, DTC P0340 CAMSHAFT POSITION SENSOR "A" CIRCUIT (BANK 1 OR SINGLE SENSOR), Diagnostic Trouble Code (DTC) Detecting Criteria.>

TROUBLE SYMPTOM:

- Engine stalls.
- Failure of engine to start

CAUTION:

After repair or replacement of faulty parts, conduct Clear Memory Mode <Ref. to EN(H4SO)(diag)-44, OPERATION, Clear Memory Mode.> and Inspection Mode <Ref. to EN(H4SO)(diag)-37, OPERATION, Inspection Mode.>.

WIRING DIAGRAM:

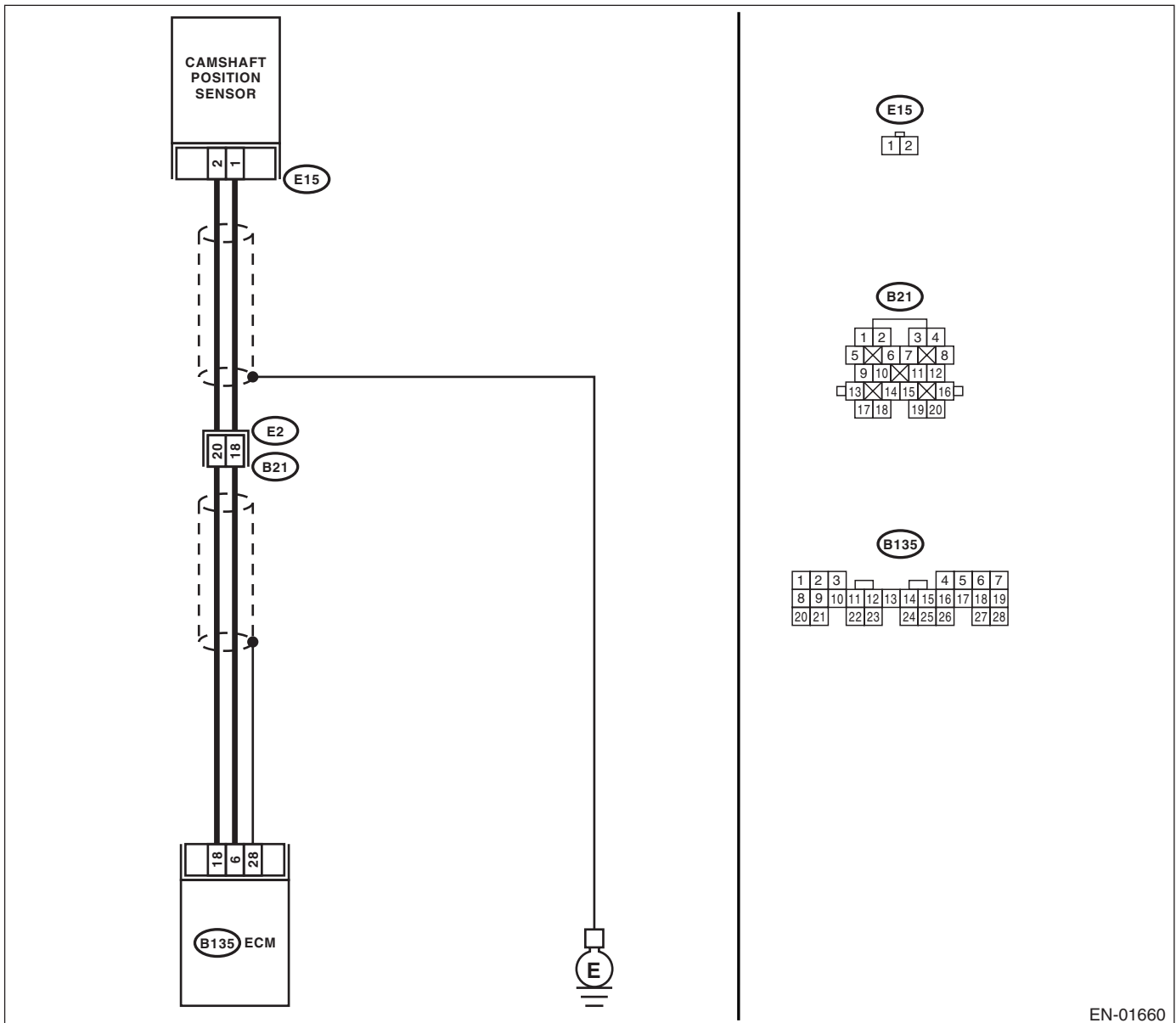

EN-01660

Diagnostic Procedure with Diagnostic Trouble Code (DTC)

ENGINE (DIAGNOSTICS)

Step	Check	Yes	No
<p>1</p> <p>CHECK HARNESS BETWEEN CAMSHAFT POSITION SENSOR AND ECM CONNECTOR.</p> <p>1) Turn the ignition switch to OFF. 2) Disconnect the connector from camshaft position sensor. 3) Measure the resistance of harness between camshaft position sensor connector and engine ground.</p> <p>Connector & terminal (E15) No. 1 — Engine ground:</p>	<p>Is the resistance more than 100 kΩ?</p>	<p>Repair harness and connector.</p> <p>NOTE: In this case, repair the following:</p> <ul style="list-style-type: none"> • Open circuit in harness between camshaft position sensor and ECM connector • Poor contact in ECM connector • Poor contact in coupling connector 	<p>Go to step 2.</p>
<p>2</p> <p>CHECK HARNESS BETWEEN CAMSHAFT POSITION SENSOR AND ECM CONNECTOR.</p> <p>Measure the resistance of harness between camshaft position sensor connector and engine ground.</p> <p>Connector & terminal (E15) No. 1 — Engine ground:</p>	<p>Is the resistance less than 10 Ω?</p>	<p>Repair ground short circuit in harness between camshaft position sensor and ECM connector.</p> <p>NOTE: The harness between both connectors are shielded. Repair ground short circuit in harness together with shield.</p>	<p>Go to step 3.</p>
<p>3</p> <p>CHECK HARNESS BETWEEN CAMSHAFT POSITION SENSOR AND ECM CONNECTOR.</p> <p>Measure the resistance of harness between camshaft position sensor connector and engine ground.</p> <p>Connector & terminal (E15) No. 2 — Engine ground:</p>	<p>Is the resistance less than 5 Ω?</p>	<p>Go to step 4.</p>	<p>Repair harness and connector.</p> <p>NOTE: In this case, repair the following:</p> <ul style="list-style-type: none"> • Open circuit in harness between camshaft position sensor and ECM connector • Poor contact in ECM connector • Poor contact in coupling connector
<p>4</p> <p>CHECK CONDITION OF CAMSHAFT POSITION SENSOR.</p>	<p>Is the camshaft position sensor installation bolt tightened securely?</p>	<p>Go to step 5.</p>	<p>Tighten camshaft position sensor installation bolt securely.</p>
<p>5</p> <p>CHECK CAMSHAFT POSITION SENSOR.</p> <p>1) Remove the camshaft position sensor. 2) Measure the resistance between connector terminals of camshaft position sensor.</p> <p>Terminals No. 1 — No. 2:</p>	<p>Is the resistance 1 — 4 kΩ?</p>	<p>Repair poor contact in camshaft position sensor connector.</p>	<p>Replace the camshaft position sensor. <Ref. to FU(H4SO)-26, Camshaft Position Sensor.></p>

Diagnostic Procedure with Diagnostic Trouble Code (DTC)

ENGINE (DIAGNOSTICS)

AS:DTC P0341 CAMSHAFT POSITION SENSOR "A" CIRCUIT RANGE/PERFORMANCE (BANK 1 OR SINGLE SENSOR)

DTC DETECTING CONDITION:

- Immediately at fault recognition
- GENERAL DESCRIPTION <Ref. to GD(H4SO)-98, DTC P0341 CAMSHAFT POSITION SENSOR "A" CIRCUIT RANGE/PERFORMANCE (BANK 1 OR SINGLE SENSOR), Diagnostic Trouble Code (DTC) Detecting Criteria.>

TROUBLE SYMPTOM:

- Engine stalls.
- Failure of engine to start

CAUTION:

After repair or replacement of faulty parts, conduct Clear Memory Mode <Ref. to EN(H4SO)(diag)-44, OPERATION, Clear Memory Mode.> and Inspection Mode <Ref. to EN(H4SO)(diag)-37, OPERATION, Inspection Mode.>.

WIRING DIAGRAM:

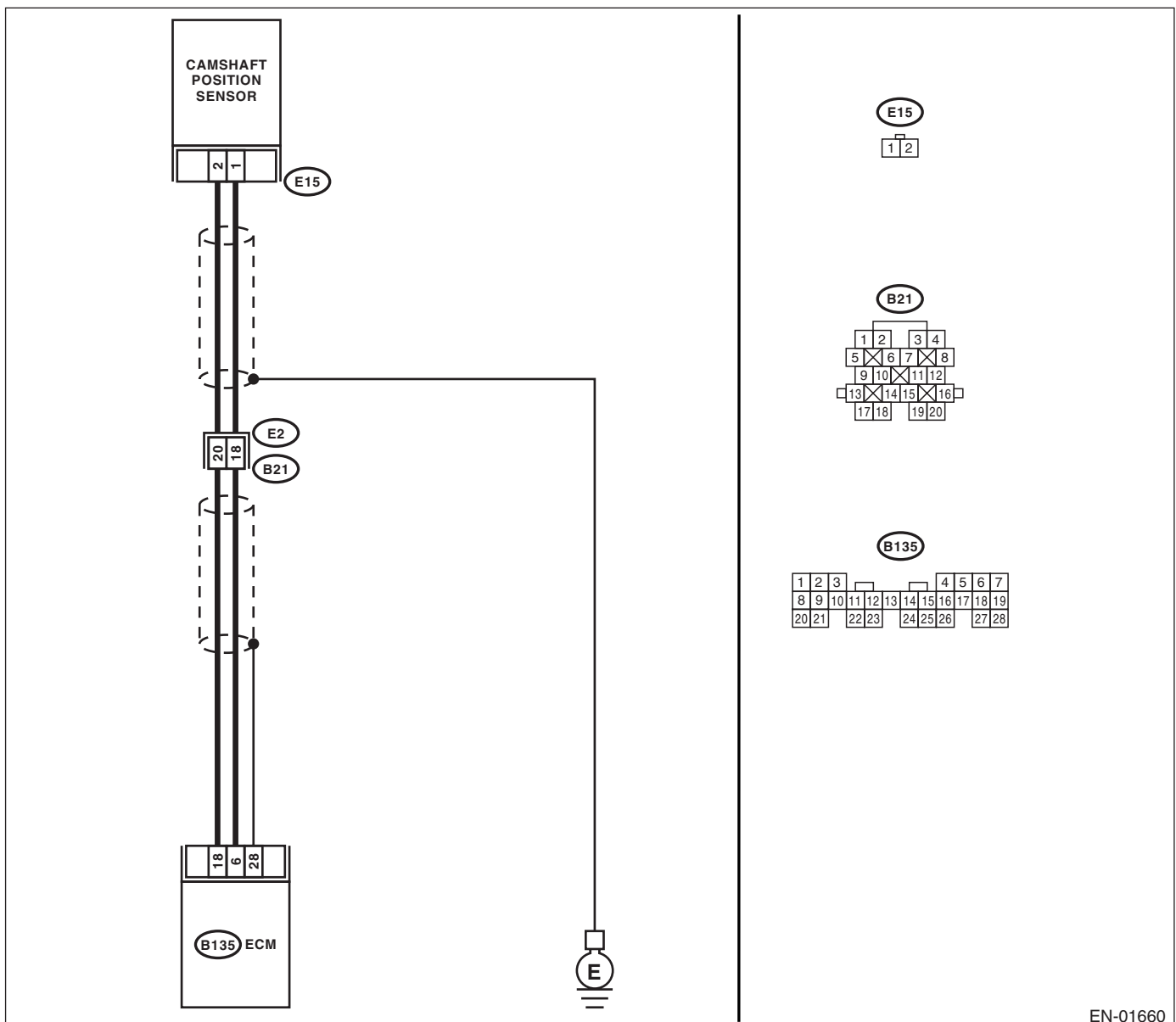

EN-01660

Diagnostic Procedure with Diagnostic Trouble Code (DTC)

ENGINE (DIAGNOSTICS)

Step	Check	Yes	No
1	CHECK ANY OTHER DTC ON DISPLAY.	Inspect DTC using "List of Diagnostic Trouble Code (DTC)". <Ref. to EN(H4SO)(diag)-71, List of Diagnostic Trouble Code (DTC).>	Go to step 2.
2	CHECK HARNESS BETWEEN CAMSHAFT POSITION SENSOR AND ECM CONNECTOR. 1) Turn the ignition switch to OFF. 2) Disconnect the connector from camshaft position sensor. 3) Measure the resistance of harness between camshaft position sensor connector and engine ground. Connector & terminal (E15) No. 1 — Engine ground:	Is the resistance more than 100 kΩ?	Repair harness and connector. NOTE: In this case, repair the following: • Open circuit in harness between camshaft position sensor and ECM connector • Poor contact in ECM connector • Poor contact in coupling connector
3	CHECK HARNESS BETWEEN CAMSHAFT POSITION SENSOR AND ECM CONNECTOR. Measure the resistance of harness between camshaft position sensor connector and engine ground. Connector & terminal (E15) No. 1 — Engine ground:	Is the resistance less than 10 Ω?	Repair ground short circuit in harness between camshaft position sensor and ECM connector. NOTE: The harness between both connectors are shielded. Repair ground short circuit in harness together with shield.
4	CHECK HARNESS BETWEEN CAMSHAFT POSITION SENSOR AND ECM CONNECTOR. Measure the resistance of harness between camshaft position sensor connector and engine ground. Connector & terminal (E15) No. 2 — Engine ground:	Is the resistance less than 5 Ω?	Go to step 5. Repair harness and connector. NOTE: In this case, repair the following: • Open circuit in harness between camshaft position sensor and ECM connector • Poor contact in ECM connector • Poor contact in coupling connector
5	CHECK CONDITION OF CAMSHAFT POSITION SENSOR.	Is the camshaft position sensor installation bolt tightened securely?	Go to step 6. Tighten camshaft position sensor installation bolt securely.

Diagnostic Procedure with Diagnostic Trouble Code (DTC)

ENGINE (DIAGNOSTICS)

Step	Check	Yes	No
6 CHECK CAMSHAFT POSITION SENSOR. 1) Remove the camshaft position sensor. 2) Measure the resistance between connector terminals of camshaft position sensor. Terminals No. 1 — No. 2:	Is the resistance 1 — 4 k Ω ?	Go to step 7.	Replace the camshaft position sensor. <Ref. to FU(H4SO)-26, Camshaft Position Sensor.>
7 CHECK CONDITION OF CAMSHAFT POSITION SENSOR. Turn the ignition switch to OFF.	Is the camshaft position sensor installation bolt tightened securely?	Go to step 8.	Tighten camshaft position sensor installation bolt securely.
8 CHECK CAMSHAFT SPROCKET. Remove the timing belt cover. <Ref. to ME(H4SO)-43, Timing Belt Cover.>	Are camshaft sprocket teeth cracked or damaged?	Replace the camshaft sprocket. <Ref. to ME(H4SO)-49, Camshaft Sprocket.>	Go to step 9.
9 CHECK INSTALLATION CONDITION OF TIMING BELT. Turn the camshaft using ST, and align alignment mark on camshaft sprocket with alignment mark on timing belt cover LH. ST 499987500 CAMSHAFT SOCKET	Is the timing belt dislocated from its proper position?	Repair installation condition of timing belt. <Ref. to ME(H4SO)-44, Timing Belt Assembly.>	Replace the camshaft position sensor. <Ref. to FU(H4SO)-26, Camshaft Position Sensor.>

Diagnostic Procedure with Diagnostic Trouble Code (DTC)

ENGINE (DIAGNOSTICS)

AT:DTC P0420 CATALYST SYSTEM EFFICIENCY BELOW THRESHOLD (BANK 1)

DTC DETECTING CONDITION:

- Two consecutive driving cycles with fault
- GENERAL DESCRIPTION <Ref. to GD(H4SO)-100, DTC P0420 CATALYST SYSTEM EFFICIENCY BELOW THRESHOLD (BANK 1), Diagnostic Trouble Code (DTC) Detecting Criteria.>

TROUBLE SYMPTOM:

- Engine stalls.
- Idle mixture is out of specifications.

CAUTION:

After repair or replacement of faulty parts, conduct Clear Memory Mode <Ref. to EN(H4SO)(diag)-44, OPERATION, Clear Memory Mode.> and Inspection Mode <Ref. to EN(H4SO)(diag)-37, OPERATION, Inspection Mode.>.

WIRING DIAGRAM:

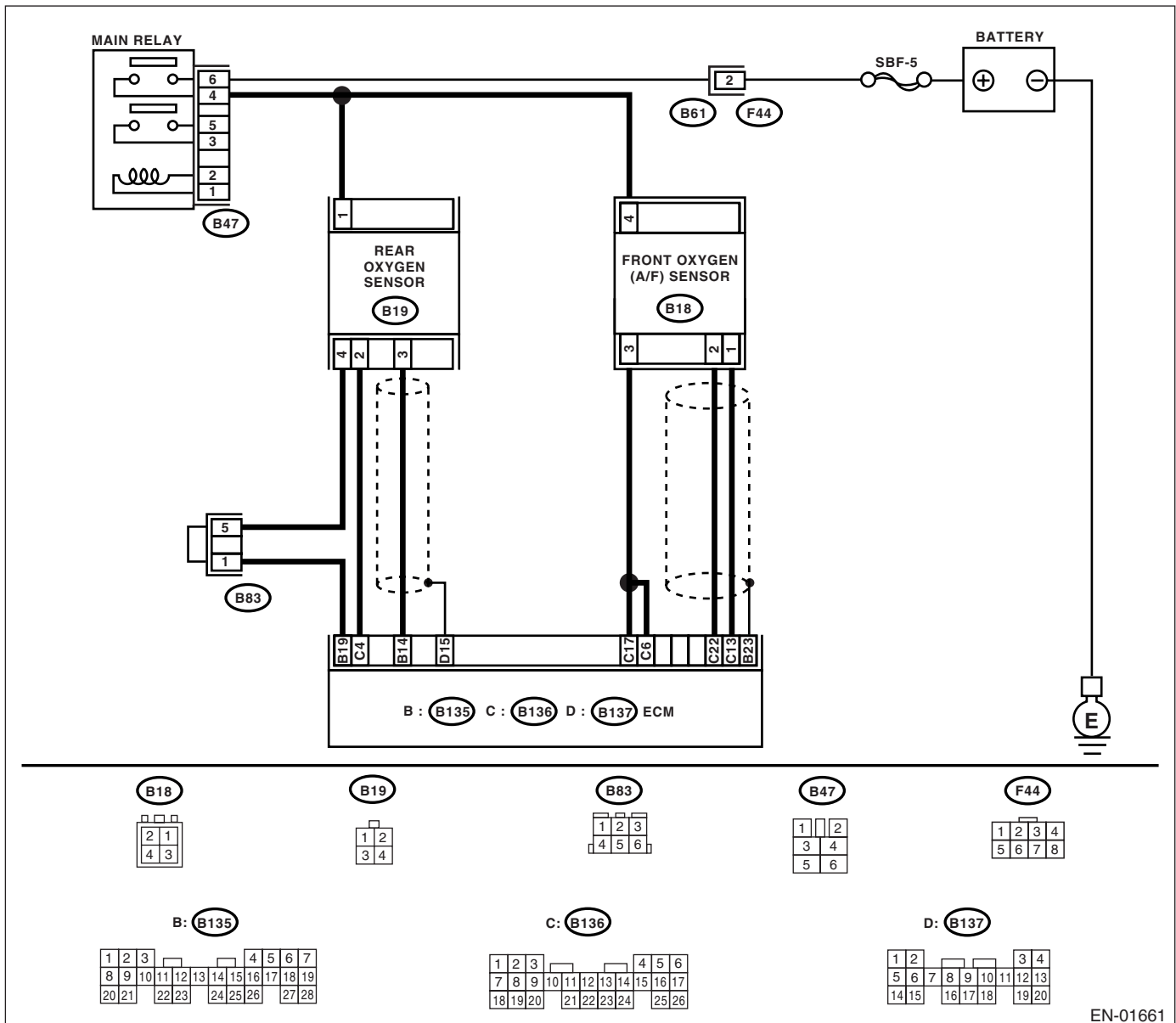

EN-01661

Diagnostic Procedure with Diagnostic Trouble Code (DTC)

ENGINE (DIAGNOSTICS)

Step	Check	Yes	No	
1	CHECK ANY OTHER DTC ON DISPLAY.	Is any other DTC displayed?	Inspect the relevant DTC using "List of Diagnostic Trouble Code (DTC)". <Ref. to EN(H4SO)(diag)-71, List of Diagnostic Trouble Code (DTC).> NOTE: In this case, it is not necessary to inspect DTC P0420.	Go to step 2.
2	CHECK EXHAUST SYSTEM. Check for gas leaks or air suction caused by loose or dislocated nuts and bolts, and open hole at exhaust pipes. NOTE: Check the following positions. <ul style="list-style-type: none"> • Between cylinder head and front exhaust pipe • Between front exhaust pipe and front catalytic converter • Between front catalytic converter and rear catalytic converter 	Is there a fault in exhaust system?	Repair or replace the exhaust system. <Ref. to EX(H4SO)-2, General Description.>	Go to step 3.
3	CHECK CATALYTIC CONVERTER.	Is there damage at rear face or front face of front catalyst?	Replace the catalytic converter. <Ref. to EC(H4SO)-3, Front Catalytic Converter.>	Contact SOA Service Center. NOTE: Inspection by DTM is required, because probable cause is deterioration of multiple parts.

AU:DTC P0442 EVAPORATIVE EMISSION CONTROL SYSTEM LEAK DETECTED (SMALL LEAK)

DTC DETECTING CONDITION:

- Two consecutive driving cycles with fault
- GENERAL DESCRIPTION <Ref. to GD(H4SO)-105, DTC P0442 EVAPORATIVE EMISSION CONTROL SYSTEM LEAK DETECTED (SMALL LEAK), Diagnostic Trouble Code (DTC) Detecting Criteria.>

TROUBLE SYMPTOM:

- Fuel odor
- There is a hole of more than 1.0 mm (0.04 in) dia. in evaporation system or fuel tank.

CAUTION:

After repair or replacement of faulty parts, conduct CLEAR MEMORY MODE <Ref. to EN(H4SO)(diag)-44, OPERATION, Clear Memory Mode.> and INSPECTION MODE <Ref. to EN(H4SO)(diag)-37, OPERATION, Inspection Mode.>.

Diagnostic Procedure with Diagnostic Trouble Code (DTC)

ENGINE (DIAGNOSTICS)

WIRING DIAGRAM:

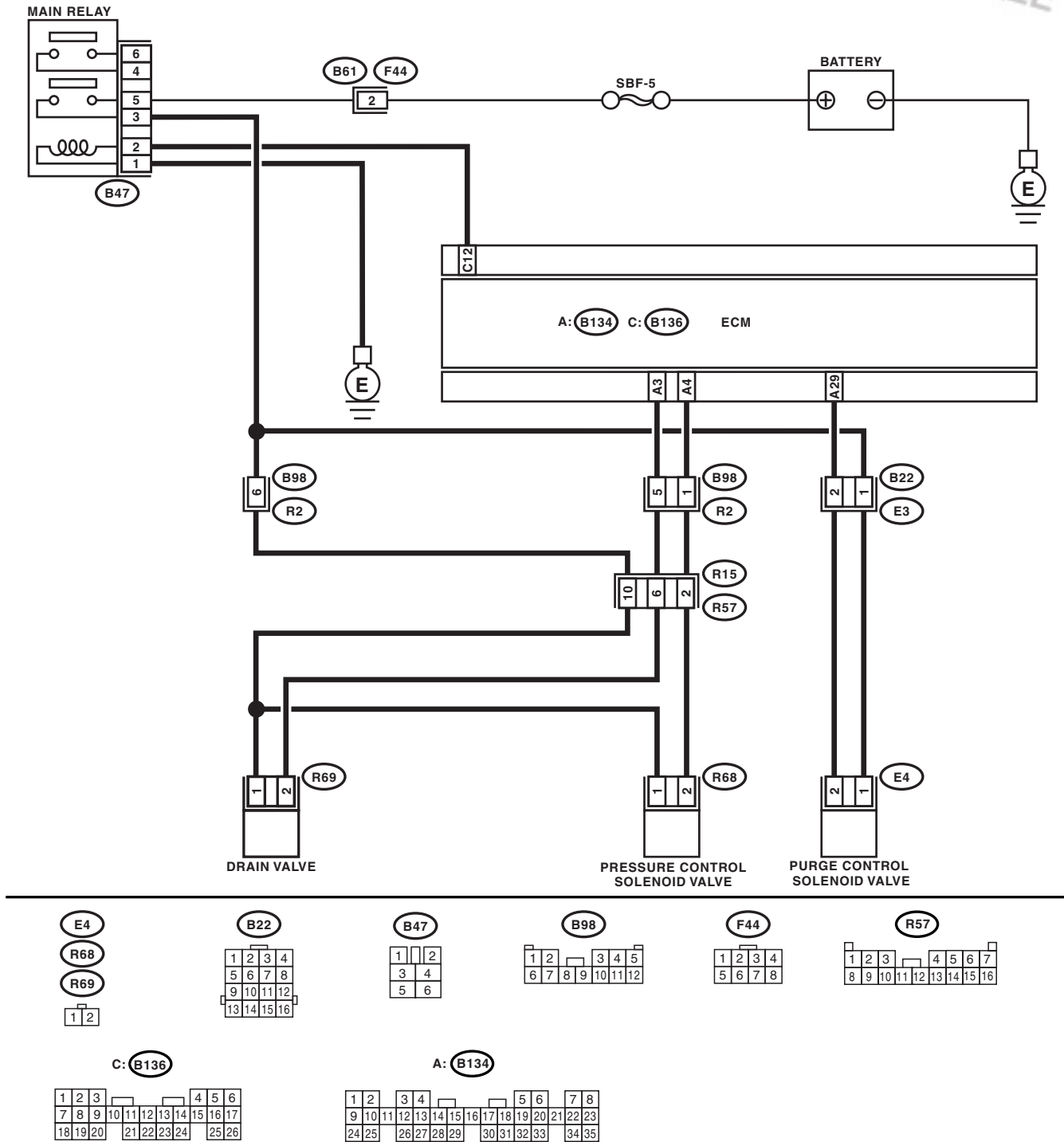

EN-01662

Diagnostic Procedure with Diagnostic Trouble Code (DTC)

ENGINE (DIAGNOSTICS)

Step	Check	Yes	No
1 CHECK FOR OTHER DTC ON DISPLAY.	Is any other DTC displayed?	Inspect the relevant DTC using "List of Diagnostic Trouble Code (DTC)". <Ref. to EN(H4SO)(diag)-71, List of Diagnostic Trouble Code (DTC).>	Go to step 2.
2 CHECK FUEL FILLER CAP. 1) Turn ignition switch to OFF. 2) Check the fuel filler cap. NOTE: The DTC is stored in memory if fuel filler cap is or was loose or if the cap chain was caught while tightening.	Is the fuel filler cap tightened securely?	Go to step 3.	Tighten fuel filler cap securely.
3 CHECK FUEL FILLER CAP.	Is the fuel filler cap SUBARU genuine?	Go to step 4.	Replace with a SUBARU genuine fuel filler cap.
4 CHECK FUEL FILLER PIPE PACKING.	Is there any damage to the seal between fuel filler cap and fuel filler pipe?	Repair or replace the fuel filler cap and fuel filler pipe. <Ref. to FU(H4SO)-51, Fuel Filler Pipe.>	Go to step 5.
5 CHECK DRAIN VALVE. 1) Connect the test mode connector. 2) Turn ignition switch to ON. 3) Operate the drain valve. NOTE: Drain valve operation can also be executed using Subaru Select Monitor. For the procedure, refer to "Compulsory Valve Operation Check Mode". <Ref. to EN(H4SO)(diag)-45, Compulsory Valve Operation Check Mode.>	Does the drain valve operate?	Go to step 6.	Replace the drain valve. <Ref. to EC(H4SO)-18, Drain Valve.>
6 CHECK PURGE CONTROL SOLENOID VALVE. Operate the purge control solenoid valve. NOTE: Purge control solenoid valve operation can also be executed using Subaru Select Monitor. For the procedure, refer to "Compulsory Valve Operation Check Mode". <Ref. to EN(H4SO)(diag)-45, Compulsory Valve Operation Check Mode.>	Does the purge control solenoid valve operate?	Go to step 7.	Replace the purge control solenoid valve. <Ref. to EC(H4SO)-6, Purge Control Solenoid Valve.>
7 CHECK PRESSURE CONTROL SOLENOID VALVE. Operate the pressure control solenoid valve. NOTE: Pressure control solenoid valve operation can also be executed using Subaru Select Monitor. For the procedure, refer to "Compulsory Valve Operation Check Mode". <Ref. to EN(H4SO)(diag)-45, Compulsory Valve Operation Check Mode.>	Does the pressure control solenoid valve operate?	Go to step 8.	Replace the pressure control solenoid valve. <Ref. to EC(H4SO)-12, Pressure Control Solenoid Valve.>

Diagnostic Procedure with Diagnostic Trouble Code (DTC)

ENGINE (DIAGNOSTICS)

Step	Check	Yes	No
8 CHECK EVAPORATIVE EMISSION CONTROL SYSTEM LINE. Turn ignition switch to OFF.	Is there a hole of more than 1.0 mm (0.04 in) dia. on evaporation line?	Repair or replace the evaporation line. <Ref. to FU(H4SO)-62, Fuel Delivery, Return and Evaporation lines.>	Go to step 9 .
9 CHECK CANISTER.	Is the canister damaged or is there a hole of more than 1.0 mm (0.04 in) dia. in it?	Repair or replace the canister. <Ref. to EC(H4SO)-5, Canister.>	Go to step 10 .
10 CHECK FUEL TANK. Remove the fuel tank. <Ref. to FU(H4SO)-48, Fuel Tank.>	Is the fuel tank damaged or is there a hole of more than 1.0 mm (0.04 in) dia. in it?	Repair or replace the fuel tank. <Ref. to FU(H4SO)-48, Fuel Tank.>	Go to step 11 .
11 CHECK ANY OTHER MECHANICAL TROUBLE IN EVAPORATIVE EMISSION CONTROL SYSTEM.	Are there holes of more than 1.0 mm (0.04 in) dia., cracks, clogging, disconnections or bend of hoses or pipes in evaporative emission control system?	Repair or replace the hoses or pipes.	Contact SOA Service Center. NOTE: Inspection by DTM is required, because probable cause is deterioration of multiple parts.

Diagnostic Procedure with Diagnostic Trouble Code (DTC)

ENGINE (DIAGNOSTICS)

AV:DTC P0447 EVAPORATIVE EMISSION CONTROL SYSTEM VENT CONTROL CIRCUIT OPEN

DTC DETECTING CONDITION:

- Two consecutive driving cycles with fault
- GENERAL DESCRIPTION <Ref. to GD(H4SO)-130, DTC P0447 EVAPORATIVE EMISSION CONTROL SYSTEM VENT CONTROL CIRCUIT OPEN, Diagnostic Trouble Code (DTC) Detecting Criteria.>

CAUTION:

After repair or replacement of faulty parts, conduct CLEAR MEMORY MODE <Ref. to EN(H4SO)(diag)-44, OPERATION, Clear Memory Mode.> and INSPECTION MODE <Ref. to EN(H4SO)(diag)-37, OPERATION, Inspection Mode.>.

WIRING DIAGRAM:

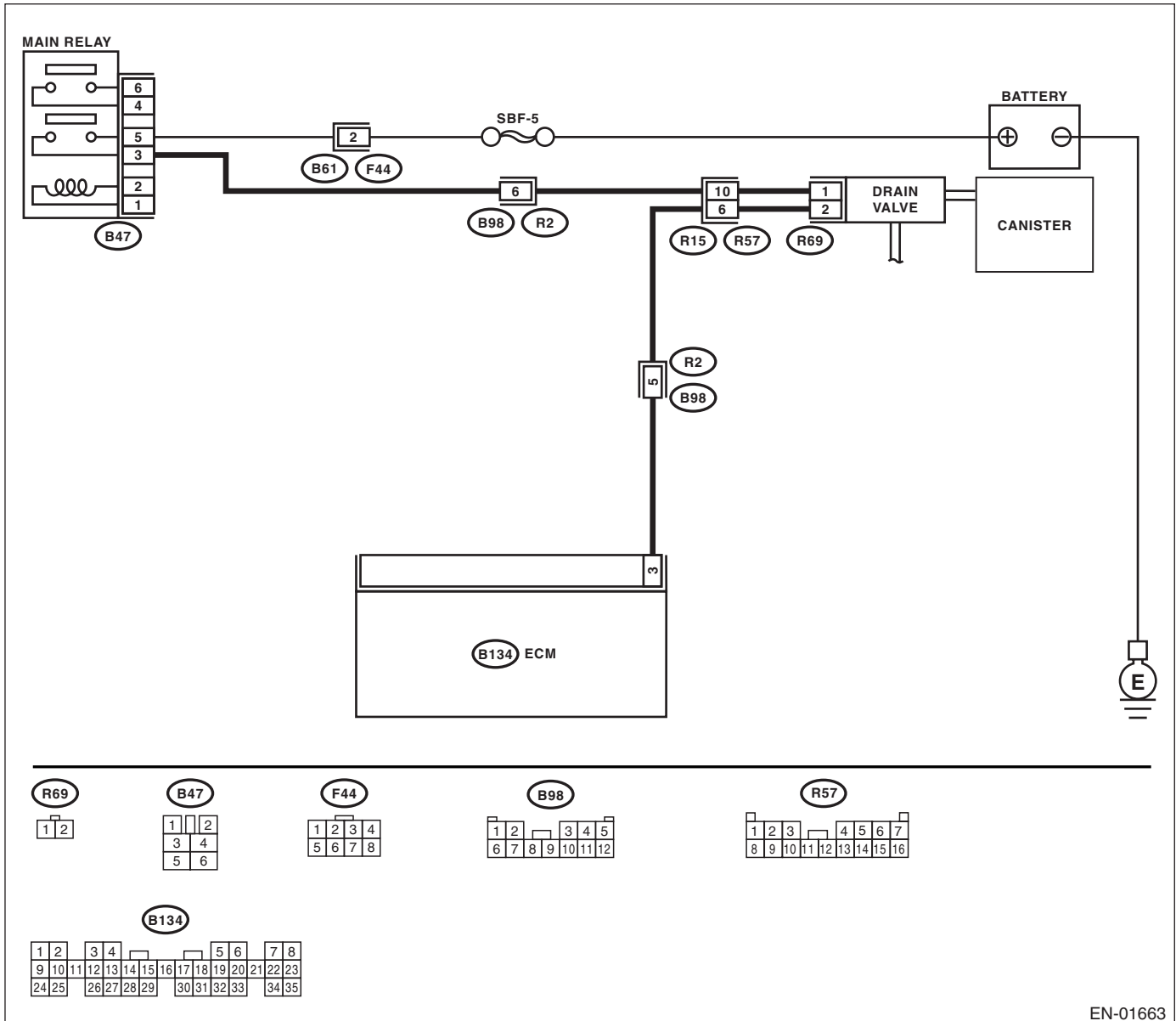

EN-01663

Diagnostic Procedure with Diagnostic Trouble Code (DTC)

ENGINE (DIAGNOSTICS)

Step	Check	Yes	No
1 CHECK OUTPUT SIGNAL FROM ECM. 1) Turn ignition switch to ON. 2) Measure the voltage between ECM and chassis ground. Connector & terminal (B134) No. 3 (+) — Chassis ground (-):	Is the voltage more than 10 V?	Go to step 2.	Go to step 3.
2 CHECK FOR POOR CONTACT. Check for poor contact in ECM connector.	Is there poor contact in ECM connector?	Repair poor contact in ECM connector.	The malfunction indicator light may light up, however, the circuit is returned to the normal status at the moment. (However, the possibility of poor contact still remains.) NOTE: In this case, repair the following: <ul style="list-style-type: none"> • Poor contact in drain valve connector • Poor contact in ECM connector • Poor contact in coupling connector
3 CHECK HARNESS BETWEEN DRAIN VALVE AND ECM CONNECTOR. 1) Turn ignition switch to OFF. 2) Disconnect the connectors from drain valve and ECM. 3) Measure the resistance of harness between drain valve connector and chassis ground. Connector & terminal (R69) No. 2 — Chassis ground:	Is the resistance more than 1 M Ω ?	Go to step 4.	Repair short circuit to ground in harness between ECM and drain valve connector.
4 CHECK HARNESS BETWEEN DRAIN VALVE AND ECM CONNECTOR. Measure the resistance of harness between ECM and drain valve connector. Connector & terminal (B134) No. 3 — (R69) No. 2:	Is the resistance less than 1 Ω ?	Go to step 5.	Repair harness and connector. NOTE: In this case, repair the following: <ul style="list-style-type: none"> • Open circuit in harness between ECM and drain valve connector • Poor contact in coupling connector
5 CHECK DRAIN VALVE. Measure the resistance between drain valve terminals. Terminals No. 1 — No. 2:	Is the resistance 10 — 100 Ω ?	Go to step 6.	Replace the drain valve. <Ref. to EC(H4SO)-18, Drain Valve.>

Diagnostic Procedure with Diagnostic Trouble Code (DTC)

ENGINE (DIAGNOSTICS)

Step	Check	Yes	No
6 CHECK POWER SUPPLY TO DRAIN VALVE. 1) Turn ignition switch to ON. 2) Measure the voltage between drain valve and chassis ground. Connector & terminal (R69) No. 1 (+) — Chassis ground (-):	Is the voltage more than 10 V?	Go to step 7.	Repair harness and connector. NOTE: In this case, repair the following: <ul style="list-style-type: none"> • Open circuit in harness between main relay and drain valve • Poor contact in coupling connector • Poor contact in main relay connector
7 CHECK FOR POOR CONTACT. Check for poor contact in drain valve connector.	Is there poor contact in drain valve connector?	Repair poor contact in drain valve connector.	Contact SOA Service Center. NOTE: Inspection by DTM is required, because probable cause is deterioration of multiple parts.

Diagnostic Procedure with Diagnostic Trouble Code (DTC)

ENGINE (DIAGNOSTICS)

AW:DTC P0448 EVAPORATIVE EMISSION CONTROL SYSTEM VENT CONTROL CIRCUIT SHORTED

DTC DETECTING CONDITION:

- Two consecutive driving cycles with fault
- GENERAL DESCRIPTION <Ref. to GD(H4SO)-132, DTC P0448 EVAPORATIVE EMISSION CONTROL SYSTEM VENT CONTROL CIRCUIT SHORTED, Diagnostic Trouble Code (DTC) Detecting Criteria.>

CAUTION:

After repair or replacement of faulty parts, conduct CLEAR MEMORY MODE <Ref. to EN(H4SO)(diag)-44, OPERATION, Clear Memory Mode.> and INSPECTION MODE <Ref. to EN(H4SO)(diag)-37, OPERATION, Inspection Mode.>.

WIRING DIAGRAM:

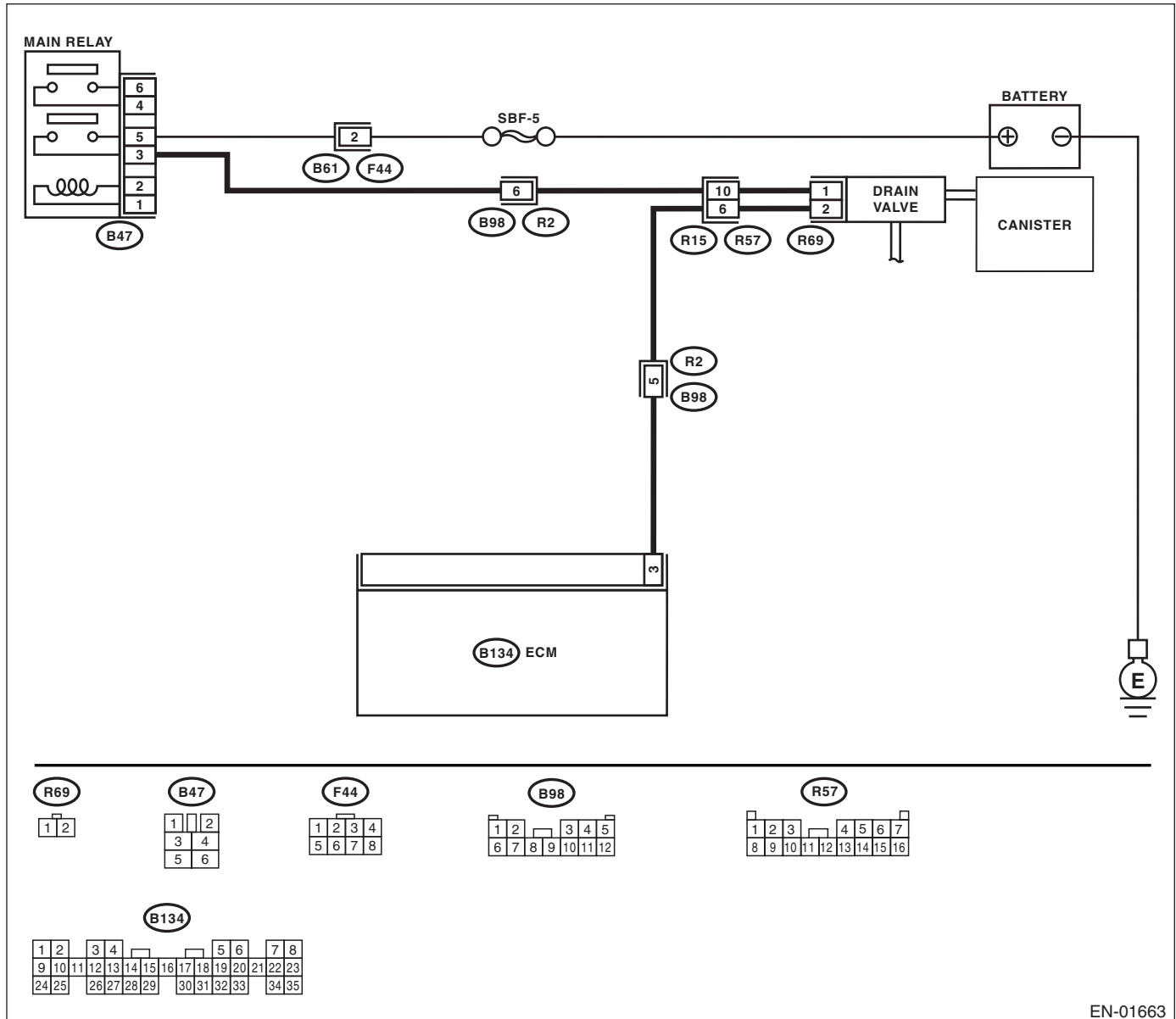

EN-01663

Diagnostic Procedure with Diagnostic Trouble Code (DTC)

ENGINE (DIAGNOSTICS)

Step	Check	Yes	No
1 CHECK INPUT SIGNAL FOR ECM. 1) Turn ignition switch to OFF. 2) Connect the test mode connector at the lower portion of instrument panel (on the driver's side). 3) Turn ignition switch to ON. 4) While operating the drain valve, measure voltage between ECM and chassis ground. NOTE: Drain valve operation can be executed using Subaru Select Monitor. For the procedure, refer to "Compulsory Valve Operation Check Mode". <Ref. to EN(H4SO)(diag)-45, Compulsory Valve Operation Check Mode.> Connector & terminal (B134) No. 3 (+) — Chassis ground (-):	Is the voltage 0 — 10 V?	Go to step 2.	The malfunction indicator light may light up, however, the circuit is returned to the normal status at the moment. In this case, repair poor contact in ECM connector.
2 CHECK INPUT SIGNAL FOR ECM. 1) Turn ignition switch to ON. 2) Measure the voltage between ECM and chassis ground. Connector & terminal (B134) No. 3 (+) — Chassis ground (-):	Is the voltage more than 10 V?	Go to step 4.	Go to step 3.
3 CHECK FOR POOR CONTACT. Check for poor contact in ECM connector.	Is there poor contact in ECM connector?	Repair poor contact in ECM connector.	Replace the ECM. <Ref. to FU(H4SO)-44, Engine Control Module (ECM).>
4 CHECK HARNESS BETWEEN DRAIN VALVE AND ECM CONNECTOR. 1) Turn ignition switch to OFF. 2) Disconnect the connector from drain valve. 3) Turn ignition switch to ON. 4) Measure the voltage between ECM and chassis ground. Connector & terminal (B134) No. 3 (+) — Chassis ground (-):	Is the voltage more than 10 V?	Repair short circuit to battery in harness between ECM and drain valve connector. After repair, replace the ECM. <Ref. to FU(H4SO)-44, Engine Control Module (ECM).>	Go to step 5.
5 CHECK DRAIN VALVE. 1) Turn ignition switch to OFF. 2) Measure the resistance between drain valve terminals. Terminals No. 1 — No. 2:	Is the resistance less than 1 Ω ?	Replace the drain valve <Ref. to EC(H4SO)-18, Drain Valve.> and ECM <Ref. to FU(H4SO)-44, Engine Control Module (ECM).>.	Go to step 6.
6 CHECK FOR POOR CONTACT. Check for poor contact in ECM connector.	Is there poor contact in ECM connector?	Repair poor contact in ECM connector.	Replace the ECM. <Ref. to FU(H4SO)-44, Engine Control Module (ECM).>

Diagnostic Procedure with Diagnostic Trouble Code (DTC)

ENGINE (DIAGNOSTICS)

AX:DTC P0451 EVAPORATIVE EMISSION CONTROL SYSTEM PRESSURE SENSOR RANGE/PERFORMANCE

DTC DETECTING CONDITION:

- Two consecutive driving cycles with fault
- GENERAL DESCRIPTION <Ref. to GD(H4SO)-134, DTC P0451 EVAPORATIVE EMISSION CONTROL SYSTEM PRESSURE SENSOR RANGE/PERFORMANCE, Diagnostic Trouble Code (DTC) Detecting Criteria.>

CAUTION:

After repair or replacement of faulty parts, conduct CLEAR MEMORY MODE <Ref. to EN(H4SO)(diag)-44, OPERATION, Clear Memory Mode.> and INSPECTION MODE <Ref. to EN(H4SO)(diag)-37, OPERATION, Inspection Mode.>.

WIRING DIAGRAM:

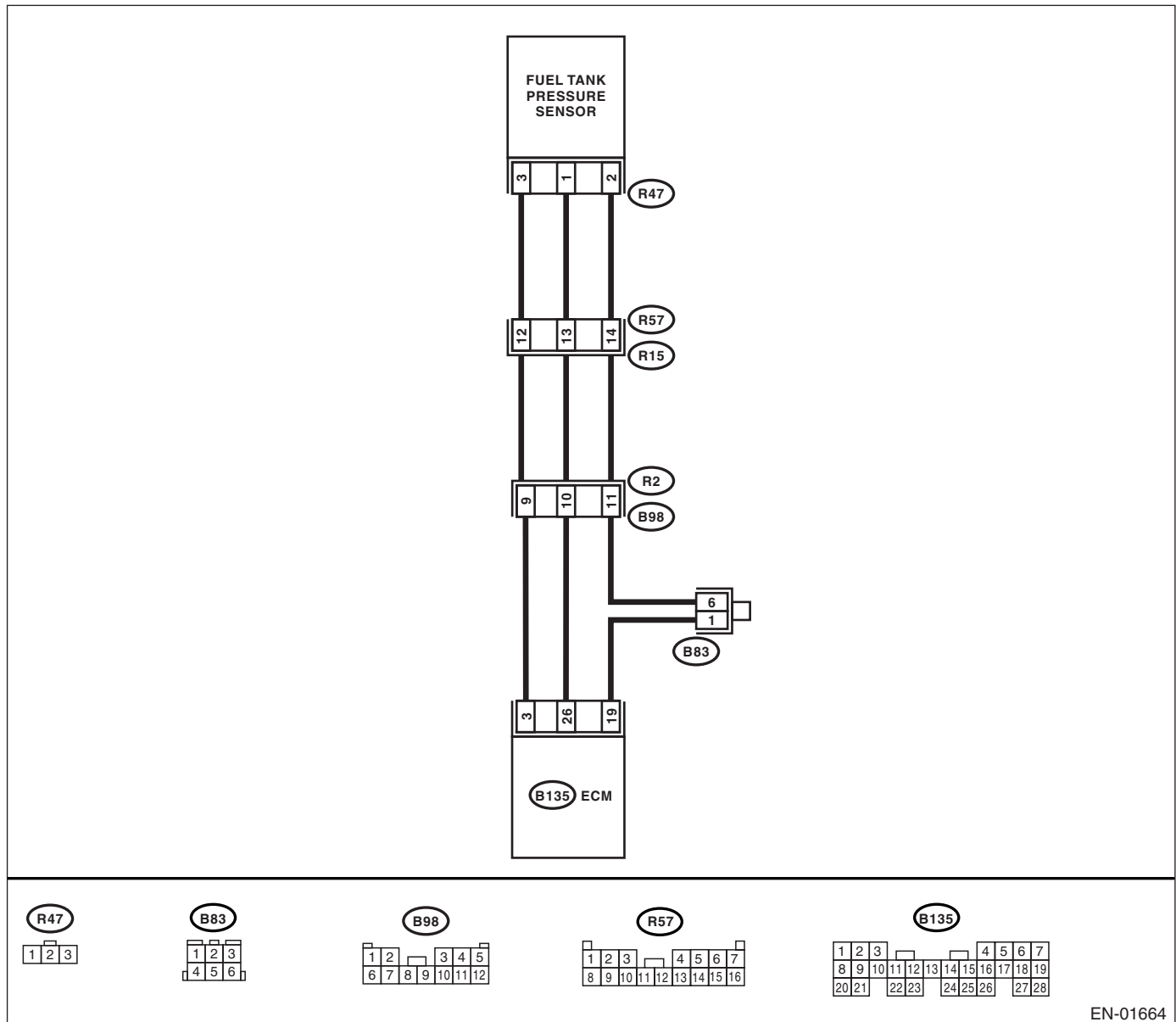

EN-01664

Diagnostic Procedure with Diagnostic Trouble Code (DTC)

ENGINE (DIAGNOSTICS)

	Step	Check	Yes	No
1	CHECK FOR OTHER DTC ON DISPLAY.	Is any other DTC displayed?	Inspect the relevant DTC using "List of Diagnostic Trouble Code (DTC)". <Ref. to EN(H4SO)(diag)-71, List of Diagnostic Trouble Code (DTC).>	Go to step 2.
2	CHECK FUEL FILLER CAP. 1) Turn ignition switch to OFF. 2) Open the fuel flap.	Is the fuel filler cap tightened securely?	Go to step 3.	Tighten fuel filler cap securely.
3	CHECK PRESSURE/VACUUM LINE. NOTE: Check the following items. <ul style="list-style-type: none">• Disconnection, leakage and clogging of the vacuum hoses and pipes between fuel tank pressure sensor and fuel tank• Disconnection, leakage and clogging of air ventilation hoses and pipes between fuel filler pipe and fuel tank	Is there a fault in pressure/vacuum line?	Repair or replace the hoses and pipes.	Replace the fuel tank pressure sensor. <Ref. to EC(H4SO)-10, Fuel Tank Pressure Sensor.>

Diagnostic Procedure with Diagnostic Trouble Code (DTC)

ENGINE (DIAGNOSTICS)

AY:DTC P0452 EVAPORATIVE EMISSION CONTROL SYSTEM PRESSURE SENSOR LOW INPUT

DTC DETECTING CONDITION:

- Two consecutive driving cycles with fault
- GENERAL DESCRIPTION <Ref. to GD(H4SO)-137, DTC P0452 EVAPORATIVE EMISSION CONTROL SYSTEM PRESSURE SENSOR LOW INPUT, Diagnostic Trouble Code (DTC) Detecting Criteria.>

CAUTION:

After repair or replacement of faulty parts, conduct CLEAR MEMORY MODE <Ref. to EN(H4SO)(diag)-44, OPERATION, Clear Memory Mode.> and INSPECTION MODE <Ref. to EN(H4SO)(diag)-37, OPERATION, Inspection Mode.>.

WIRING DIAGRAM:

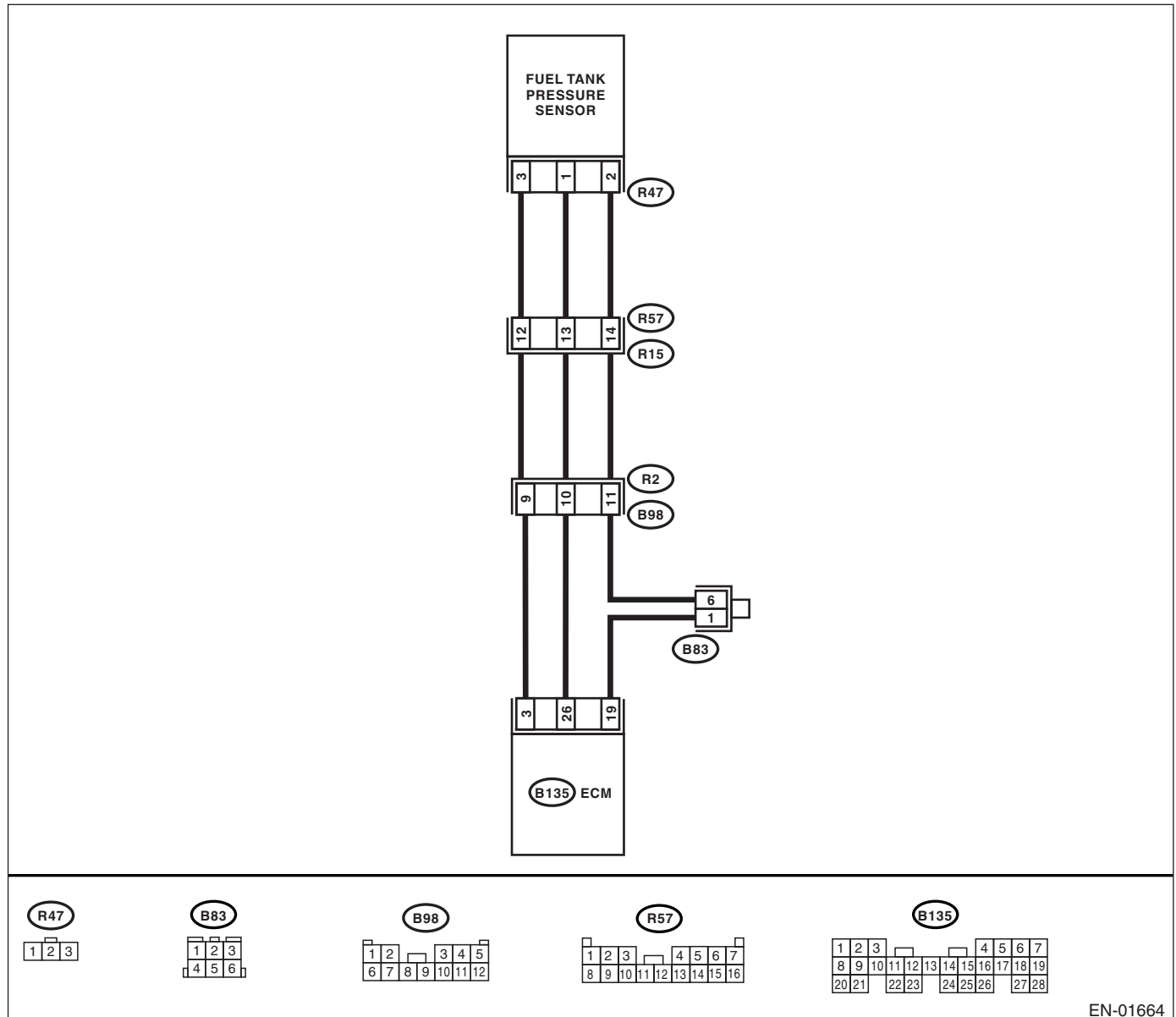

EN-01664

Diagnostic Procedure with Diagnostic Trouble Code (DTC)

ENGINE (DIAGNOSTICS)

Step	Check	Yes	No
<p>1 CHECK CURRENT DATA.</p> <p>1) Turn ignition switch to OFF. 2) Remove the fuel filler cap. 3) Install the fuel filler cap. 4) Turn ignition switch to ON. 5) Read the data of fuel tank pressure sensor signal using Subaru Select Monitor or the OBD-II general scan tool.</p> <p>NOTE:</p> <ul style="list-style-type: none"> • Subaru Select Monitor <p>For detailed operation procedures, refer to "READ CURRENT DATA FOR ENGINE". <Ref. to EN(H4SO)(diag)-30, Subaru Select Monitor.></p> <ul style="list-style-type: none"> • OBD-II general scan tool <p>For detailed operation procedures, refer to the OBD-II General Scan Tool Instruction Manual.</p>	<p>Is the measured value less than -2.8 kPa (-21.0 mmHg, -0.827 inHg)?</p>	<p>Go to step 2.</p>	<p>The malfunction indicator light may light up, however, the circuit is returned to the normal status at the moment.</p>
<p>2 CHECK POWER SUPPLY TO FUEL TANK PRESSURE SENSOR.</p> <p>Measure the voltage between ECM connector and chassis ground.</p> <p>Connector & terminal (B135) No. 3 (+) — Chassis ground (-):</p>	<p>Is the voltage more than 4.5 V?</p>	<p>Go to step 4.</p>	<p>Go to step 3.</p>
<p>3 CHECK POWER SUPPLY TO FUEL TANK PRESSURE SENSOR.</p> <p>Measure the voltage between ECM connector and chassis ground.</p> <p>Connector & terminal (B135) No. 3 (+) — Chassis ground (-):</p>	<p>Does the voltage change by shaking the ECM harness and connector?</p>	<p>Repair poor contact in ECM connector.</p>	<p>Contact SOA Service Center.</p> <p>NOTE: Inspection by DTM is required, because probable cause is deterioration of multiple parts.</p>
<p>4 CHECK INPUT SIGNAL FOR ECM.</p> <p>Measure the voltage between ECM and chassis ground.</p> <p>Connector & terminal (B135) No. 26 (+) — Chassis ground (-):</p>	<p>Is the voltage less than 0.2 V?</p>	<p>Go to step 6.</p>	<p>Go to step 5.</p>
<p>5 CHECK INPUT SIGNAL FOR ECM. (USING SUBARU SELECT MONITOR.)</p> <p>Read the data of fuel tank pressure sensor signal using Subaru Select Monitor.</p> <p>NOTE:</p> <ul style="list-style-type: none"> • Subaru Select Monitor <p>For detailed operation procedures, refer to "READ CURRENT DATA FOR ENGINE". <Ref. to EN(H4SO)(diag)-30, Subaru Select Monitor.></p>	<p>Does the measured value change by shaking the ECM harness and connector?</p>	<p>Repair poor contact in ECM connector.</p>	<p>Go to step 6.</p>
<p>6 CHECK HARNESS BETWEEN ECM AND COUPLING CONNECTOR IN REAR WIRING HARNESS.</p> <p>1) Turn ignition switch to OFF. 2) Remove the rear seat cushion. 3) Separate rear wiring harness and fuel tank cord. 4) Turn ignition switch to ON. 5) Measure the voltage between rear wiring harness connector and chassis ground.</p> <p>Connector & terminal (R15) No. 12 (+) — Chassis ground (-):</p>	<p>Is the voltage more than 4.5 V?</p>	<p>Go to step 7.</p>	<p>Repair harness and connector.</p> <p>NOTE: In this case, repair the following:</p> <ul style="list-style-type: none"> • Open circuit in harness between ECM and rear wiring harness connector • Poor contact in coupling connector

Diagnostic Procedure with Diagnostic Trouble Code (DTC)

ENGINE (DIAGNOSTICS)

Step	Check	Yes	No
<p>7 CHECK HARNESS BETWEEN ECM AND COUPLING CONNECTOR IN REAR WIRING HARNESS. 1) Turn ignition switch to OFF. 2) Disconnect the connector from ECM. 3) Measure the resistance of harness between ECM and rear wiring harness connector. <i>Connector & terminal</i> <i>(B135) No. 19 — (R15) No. 14:</i></p>	Is the resistance less than 1 Ω ?	Go to step 8.	Repair harness and connector. NOTE: In this case, repair the following: <ul style="list-style-type: none"> • Open circuit in harness between ECM and rear wiring harness connector • Poor contact in coupling connector • Poor contact in joint connector
<p>8 CHECK HARNESS BETWEEN ECM AND COUPLING CONNECTOR IN REAR WIRING HARNESS. Measure the resistance of harness between rear wiring harness connector and chassis ground. <i>Connector & terminal</i> <i>(R15) No. 14 (+) — Chassis ground:</i></p>	Is the resistance more than 1 $M\Omega$?	Go to step 9.	Repair short circuit to ground in harness between ECM and rear wiring harness connector.
<p>9 CHECK FUEL TANK CORD. 1) Disconnect the connector from fuel tank pressure sensor. 2) Measure the resistance of fuel tank cord. <i>Connector & terminal</i> <i>(R57) No. 12 — (R47) No. 3:</i></p>	Is the resistance less than 1 Ω ?	Go to step 10.	Repair open circuit in fuel tank cord.
<p>10 CHECK FUEL TANK CORD. Measure the resistance of fuel tank cord. <i>Connector & terminal</i> <i>(R57) No. 14 — (R47) No. 2:</i></p>	Is the resistance less than 1 Ω ?	Go to step 11.	Repair open circuit in fuel tank cord.
<p>11 CHECK FUEL TANK CORD. Measure the resistance of harness between fuel tank pressure sensor connector and engine ground. <i>Connector & terminal</i> <i>(R47) No. 1 — Chassis ground:</i></p>	Is the resistance more than 1 $M\Omega$?	Go to step 12.	Repair short circuit to ground in fuel tank cord.
<p>12 CHECK FOR POOR CONTACT. Check for poor contact in fuel tank pressure sensor connector.</p>	Is there poor contact in fuel tank pressure sensor connector?	Repair poor contact in fuel tank pressure sensor connector.	Replace the fuel tank pressure sensor. <Ref. to EC(H4SO)-10, Fuel Tank Pressure Sensor.>

Diagnostic Procedure with Diagnostic Trouble Code (DTC)

ENGINE (DIAGNOSTICS)

AZ:DTC P0453 EVAPORATIVE EMISSION CONTROL SYSTEM PRESSURE SENSOR HIGH INPUT

DTC DETECTING CONDITION:

- Two consecutive driving cycles with fault
- GENERAL DESCRIPTION <Ref. to GD(H4SO)-139, DTC P0453 EVAPORATIVE EMISSION CONTROL SYSTEM PRESSURE SENSOR HIGH INPUT, Diagnostic Trouble Code (DTC) Detecting Criteria.>

CAUTION:

After repair or replacement of faulty parts, conduct CLEAR MEMORY MODE <Ref. to EN(H4SO)(diag)-44, OPERATION, Clear Memory Mode.> and INSPECTION MODE <Ref. to EN(H4SO)(diag)-37, OPERATION, Inspection Mode.>.

WIRING DIAGRAM:

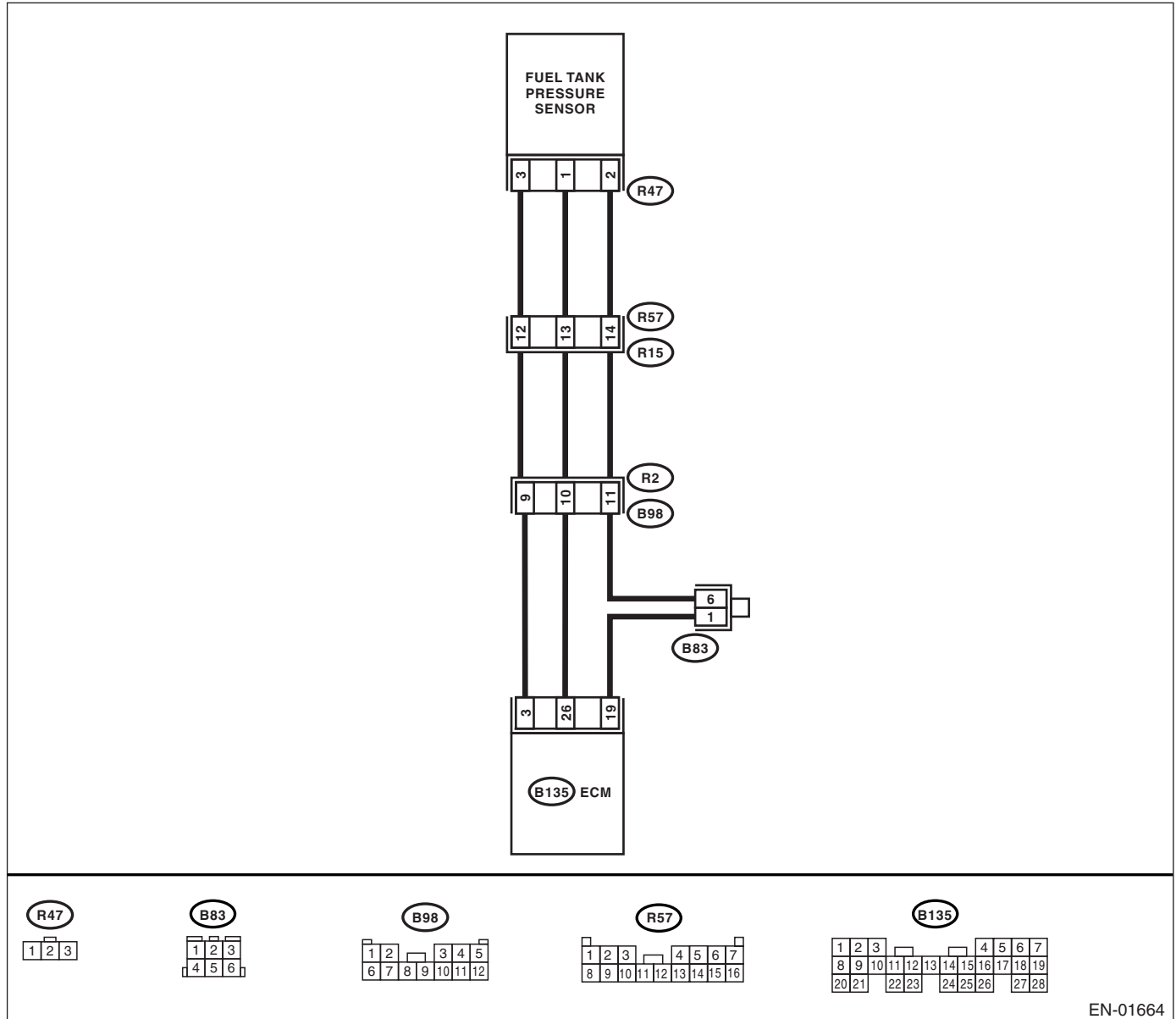

EN-01664

Diagnostic Procedure with Diagnostic Trouble Code (DTC)

ENGINE (DIAGNOSTICS)

Step	Check	Yes	No
<p>1</p> <p>CHECK CURRENT DATA.</p> <ol style="list-style-type: none"> 1) Turn ignition switch to OFF. 2) Remove the fuel filler cap. 3) Install the fuel filler cap. 4) Turn ignition switch to ON. 5) Read the data of fuel tank pressure sensor signal using Subaru Select Monitor or the OBD-II general scan tool. <p>NOTE:</p> <ul style="list-style-type: none"> • Subaru Select Monitor <p>For detailed operation procedures, refer to "READ CURRENT DATA FOR ENGINE". <Ref. to EN(H4SO)(diag)-30, Subaru Select Monitor.></p> <ul style="list-style-type: none"> • OBD-II general scan tool <p>For detailed operation procedures, refer to the OBD-II General Scan Tool Instruction Manual.</p>	<p>Is the measured value more than 2.8 kPa (21.0 mmHg, 0.827 inHg)?</p>	<p>Go to step 11.</p>	<p>Go to step 2.</p>
<p>2</p> <p>CHECK POWER SUPPLY TO FUEL TANK PRESSURE SENSOR.</p> <p>Measure the voltage between ECM connector and chassis ground.</p> <p>Connector & terminal (B135) No. 3 (+) — Chassis ground (-):</p>	<p>Is the voltage more than 4.5 V?</p>	<p>Go to step 4.</p>	<p>Go to step 3.</p>
<p>3</p> <p>CHECK POWER SUPPLY TO FUEL TANK PRESSURE SENSOR.</p> <p>Measure the voltage between ECM connector and chassis ground.</p> <p>Connector & terminal (B135) No. 3 (+) — Chassis ground (-):</p>	<p>Does the voltage change by shaking the ECM harness and connector?</p>	<p>Repair poor contact in ECM connector.</p>	<p>Replace the ECM. <Ref. to FU(H4SO)-44, Engine Control Module (ECM).></p>
<p>4</p> <p>CHECK INPUT SIGNAL FOR ECM.</p> <p>Measure the voltage between ECM and chassis ground.</p> <p>Connector & terminal (B135) No. 26 (+) — Chassis ground (-):</p>	<p>Is the voltage less than 0.2 V?</p>	<p>Go to step 6.</p>	<p>Go to step 5.</p>
<p>5</p> <p>CHECK INPUT SIGNAL FOR ECM. (USING SUBARU SELECT MONITOR.)</p> <p>Read the data of fuel tank pressure sensor signal using Subaru Select Monitor.</p> <p>NOTE:</p> <ul style="list-style-type: none"> • Subaru Select Monitor <p>For detailed operation procedures, refer to "READ CURRENT DATA FOR ENGINE". <Ref. to EN(H4SO)(diag)-30, Subaru Select Monitor.></p>	<p>Does the measured value change by shaking the ECM harness and connector?</p>	<p>Repair poor contact in ECM connector.</p>	<p>Go to step 6.</p>
<p>6</p> <p>CHECK HARNESS BETWEEN ECM AND COUPLING CONNECTOR IN REAR WIRING HARNESS.</p> <ol style="list-style-type: none"> 1) Turn ignition switch to OFF. 2) Remove the rear seat cushion. 3) Separate rear wiring harness and fuel tank cord. 4) Turn ignition switch to ON. 5) Measure the voltage between rear wiring harness connector and chassis ground. <p>Connector & terminal (R15) No. 12 (+) — Chassis ground (-):</p>	<p>Is the voltage more than 4.5 V?</p>	<p>Go to step 7.</p>	<p>Repair harness and connector.</p> <p>NOTE:</p> <p>In this case, repair the following:</p> <ul style="list-style-type: none"> • Open circuit in harness between ECM and rear wiring harness connector • Poor contact in coupling connector

Diagnostic Procedure with Diagnostic Trouble Code (DTC)

ENGINE (DIAGNOSTICS)

Step	Check	Yes	No
7 CHECK HARNESS BETWEEN ECM AND COUPLING CONNECTOR IN REAR WIRING HARNESS. 1) Turn ignition switch to OFF. 2) Disconnect the connector from ECM. 3) Measure the resistance of harness between ECM and rear wiring harness connector. Connector & terminal (B135) No. 26 — (R15) No. 13: (B135) No. 19 — (R15) No. 14:	Is the resistance less than 1 Ω ?	Go to step 8.	Repair harness and connector. NOTE: In this case, repair the following: <ul style="list-style-type: none"> • Open circuit in harness between ECM and rear wiring harness connector • Poor contact in coupling connector
8 CHECK FUEL TANK CORD. 1) Disconnect the connector from fuel tank pressure sensor. 2) Measure the resistance of fuel tank cord. Connector & terminal (R57) No. 13 — (R47) No. 1:	Is the resistance less than 1 Ω ?	Go to step 9.	Repair open circuit in fuel tank cord.
9 CHECK FUEL TANK CORD. Measure the resistance of fuel tank cord. Connector & terminal (R57) No. 14 — (R47) No. 2:	Is the resistance less than 1 Ω ?	Go to step 10.	Repair open circuit in fuel tank cord.
10 CHECK FOR POOR CONTACT. Check for poor contact in fuel tank pressure sensor connector.	Is there poor contact in fuel tank pressure sensor connector?	Repair poor contact in fuel tank pressure sensor connector.	Replace the fuel tank pressure sensor. <Ref. to EC(H4SO)-10, Fuel Tank Pressure Sensor.>
11 CHECK HARNESS BETWEEN ECM AND FUEL TANK PRESSURE SENSOR CONNECTOR. 1) Turn ignition switch to OFF. 2) Disconnect the connector from fuel tank pressure sensor. 3) Turn ignition switch to ON. 4) Read the data of fuel tank pressure sensor signal using Subaru Select Monitor or the OBD-II general scan tool. NOTE: <ul style="list-style-type: none"> • Subaru Select Monitor For detailed operation procedures, refer to "READ CURRENT DATA FOR ENGINE". <Ref. to EN(H4SO)(diag)-30, Subaru Select Monitor.> • OBD-II general scan tool For detailed operation procedures, refer to the OBD-II General Scan Tool Instruction Manual. 	Is the measured value more than 2.8 kPa (21.0 mmHg, 0.827 inHg)?	Repair short circuit to battery in harness between ECM and fuel tank pressure sensor connector.	Replace the fuel tank pressure sensor. <Ref. to EC(H4SO)-10, Fuel Tank Pressure Sensor.>

Diagnostic Procedure with Diagnostic Trouble Code (DTC)

ENGINE (DIAGNOSTICS)

BA:DTC P0456 EVAPORATIVE EMISSION CONTROL SYSTEM LEAK DETECTED (VERY SMALL LEAK)

DTC DETECTING CONDITION:

- Two consecutive driving cycles with fault
- GENERAL DESCRIPTION <Ref. to GD(H4SO)-140, DTC P0456 EVAPORATIVE EMISSION CONTROL SYSTEM LEAK DETECTED (VERY SMALL LEAK), Diagnostic Trouble Code (DTC) Detecting Criteria.>

TROUBLE SYMPTOM:

- Fuel odor
- There is a hole of more than 0.5 mm (0.020 in) dia. in evaporation system or fuel tank.

CAUTION:

After repair or replacement of faulty parts, conduct **CLEAR MEMORY MODE** <Ref. to EN(H4SO)(diag)-44, OPERATION, Clear Memory Mode.> and **INSPECTION MODE** <Ref. to EN(H4SO)(diag)-37, OPERATION, Inspection Mode.>.

Diagnostic Procedure with Diagnostic Trouble Code (DTC)

ENGINE (DIAGNOSTICS)

WIRING DIAGRAM:

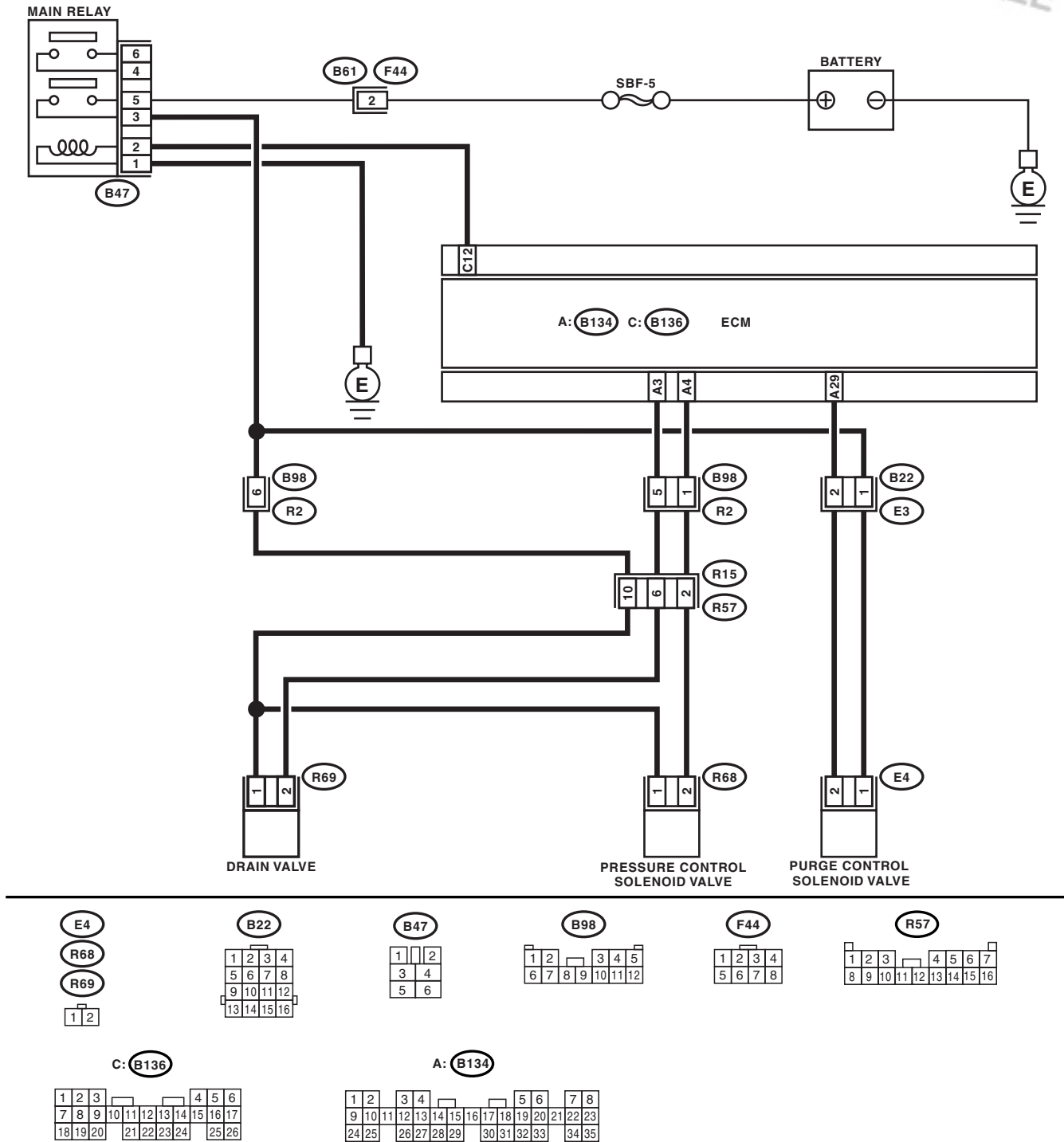

EN-01662

Diagnostic Procedure with Diagnostic Trouble Code (DTC)

ENGINE (DIAGNOSTICS)

Step	Check	Yes	No
1	CHECK FOR OTHER DTC ON DISPLAY.	Is any other DTC displayed?	Inspect the relevant DTC using "List of Diagnostic Trouble Code (DTC)". <Ref. to EN(H4SO)(diag)-71, List of Diagnostic Trouble Code (DTC).>
2	CHECK FUEL FILLER CAP. 1) Turn ignition switch to OFF. 2) Check the fuel filler cap. NOTE: The DTC is stored in memory if fuel filler cap is or was loose or if the cap chain was caught while tightening.	Is the fuel filler cap tightened securely?	Go to step 3. Tighten fuel filler cap securely.
3	CHECK FUEL FILLER CAP.	Is the fuel filler cap SUBARU genuine?	Go to step 4. Replace with a SUBARU genuine fuel filler cap.
4	CHECK FUEL FILLER PIPE PACKING.	Is there any damage to the seal between fuel filler cap and fuel filler pipe?	Repair or replace the fuel filler cap and fuel filler pipe. <Ref. to FU(H4SO)-51, Fuel Filler Pipe.>
5	CHECK DRAIN VALVE. 1) Connect the test mode connector. 2) Turn ignition switch to ON. 3) Operate the drain valve. NOTE: Drain valve operation can also be executed using Subaru Select Monitor. For the procedure, refer to "Compulsory Valve Operation Check Mode". <Ref. to EN(H4SO)(diag)-45, Compulsory Valve Operation Check Mode.>	Does the drain valve operate?	Go to step 6. Replace the drain valve. <Ref. to EC(H4SO)-18, Drain Valve.>
6	CHECK PURGE CONTROL SOLENOID VALVE. Operate the purge control solenoid valve. NOTE: Purge control solenoid valve operation can also be executed using Subaru Select Monitor. For the procedure, refer to "Compulsory Valve Operation Check Mode". <Ref. to EN(H4SO)(diag)-45, Compulsory Valve Operation Check Mode.>	Does the purge control solenoid valve operate?	Go to step 7. Replace the purge control solenoid valve. <Ref. to EC(H4SO)-6, Purge Control Solenoid Valve.>
7	CHECK PRESSURE CONTROL SOLENOID VALVE. Operate the pressure control solenoid valve. NOTE: Pressure control solenoid valve operation can also be executed using Subaru Select Monitor. For the procedure, refer to "Compulsory Valve Operation Check Mode". <Ref. to EN(H4SO)(diag)-45, Compulsory Valve Operation Check Mode.>	Does the pressure control solenoid valve operate?	Go to step 8. Replace the pressure control solenoid valve. <Ref. to EC(H4SO)-6, Purge Control Solenoid Valve.>

Diagnostic Procedure with Diagnostic Trouble Code (DTC)

ENGINE (DIAGNOSTICS)

Step	Check	Yes	No	
8	CHECK EVAPORATIVE EMISSION CONTROL SYSTEM LINE. Turn ignition switch to OFF.	Is there a hole of more than 0.5 mm (0.020 in) dia. on evaporation line?	Repair or replace the evaporation line. <Ref. to FU(H4SO)-62, Fuel Delivery, Return and Evaporation lines.>	Go to step 9 .
9	CHECK CANISTER.	Is the canister damaged or is there a hole of more than 0.5 mm (0.020 in) dia. in it?	Repair or replace the canister. <Ref. to EC(H4SO)-5, Canister.>	Go to step 10 .
10	CHECK FUEL TANK. Remove the fuel tank. <Ref. to FU(H4SO)-48, Fuel Tank.>	Is the fuel tank damaged or is there a hole of more than 0.5 mm (0.020 in) dia. in it?	Repair or replace the fuel tank. <Ref. to FU(H4SO)-48, Fuel Tank.>	Go to step 11 .
11	CHECK ANY OTHER MECHANICAL TROUBLE IN EVAPORATIVE EMISSION CONTROL SYSTEM.	Are there holes of more than 0.5 mm (0.020 in) dia., cracks, clogging, disconnections or bend of hoses or pipes in evaporative emission control system?	Repair or replace the hoses or pipes.	Contact SOA Service Center. NOTE: Inspection by DTM is required, because probable cause is deterioration of multiple parts.

BB:DTC P0457 EVAPORATIVE EMISSION CONTROL SYSTEM LEAK DETECTED (FUEL CAP LOOSE/OFF)

DTC DETECTING CONDITION:

- Two consecutive driving cycles with fault
- GENERAL DESCRIPTION <Ref. to GD(H4SO)-140, DTC P0457 EVAPORATIVE EMISSION CONTROL SYSTEM LEAK DETECTED (FUEL CAP LOOSE/OFF), Diagnostic Trouble Code (DTC) Detecting Criteria.>

TROUBLE SYMPTOM:

- Fuel odor
- Fuel filler cap is loose or not installed.

CAUTION:

After repair or replacement of faulty parts, conduct CLEAR MEMORY MODE <Ref. to EN(H4SO)(diag)-44, OPERATION, Clear Memory Mode.> and INSPECTION MODE <Ref. to EN(H4SO)(diag)-37, OPERATION, Inspection Mode.>

Diagnostic Procedure with Diagnostic Trouble Code (DTC)

ENGINE (DIAGNOSTICS)

WIRING DIAGRAM:

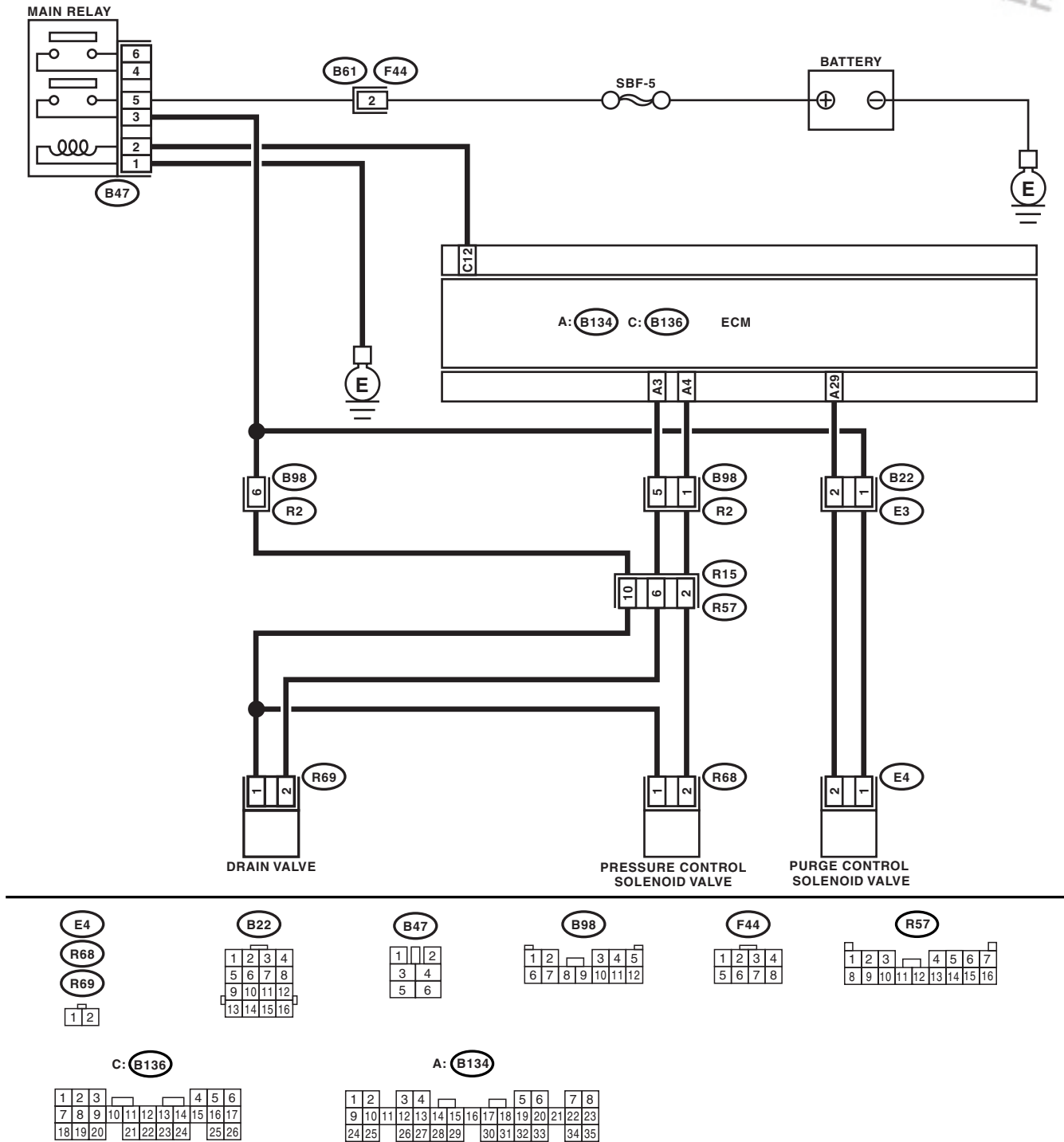

EN-01662

Diagnostic Procedure with Diagnostic Trouble Code (DTC)

ENGINE (DIAGNOSTICS)

Step	Check	Yes	No	
1	CHECK FOR OTHER DTC ON DISPLAY.	Is any other DTC displayed?	Inspect the relevant DTC using "List of Diagnostic Trouble Code (DTC)". <Ref. to EN(H4SO)(diag)-71, List of Diagnostic Trouble Code (DTC).>	Go to step 2.
2	CHECK FUEL FILLER CAP. 1) Turn ignition switch to OFF. 2) Check the fuel filler cap. NOTE: The DTC is stored in memory if fuel filler cap is or was loose or if the cap chain was caught while tightening.	Is the fuel filler cap tightened securely?	Go to step 3.	Tighten fuel filler cap securely.
3	CHECK FUEL FILLER CAP.	Is the fuel filler cap SUBARU genuine?	Go to step 4.	Replace with a SUBARU genuine fuel filler cap.
4	CHECK FUEL FILLER PIPE PACKING.	Is there any damage to the seal between fuel filler cap and fuel filler pipe?	Repair or replace the fuel filler cap and fuel filler pipe. <Ref. to FU(H4SO)-51, Fuel Filler Pipe.>	Go to step 5.
5	CHECK DRAIN VALVE. 1) Connect the test mode connector. 2) Turn ignition switch to ON. 3) Operate the drain valve. NOTE: Drain valve operation can also be executed using Subaru Select Monitor. For the procedure, refer to "Compulsory Valve Operation Check Mode". <Ref. to EN(H4SO)(diag)-45, Compulsory Valve Operation Check Mode.>	Does the drain valve operate?	Go to step 6.	Replace the drain valve. <Ref. to EC(H4SO)-18, Drain Valve.>
6	CHECK PURGE CONTROL SOLENOID VALVE. Operate the purge control solenoid valve. NOTE: Purge control solenoid valve operation can also be executed using Subaru Select Monitor. For the procedure, refer to "Compulsory Valve Operation Check Mode". <Ref. to EN(H4SO)(diag)-45, Compulsory Valve Operation Check Mode.>	Does the purge control solenoid valve operate?	Go to step 7.	Replace the purge control solenoid valve. <Ref. to EC(H4SO)-6, Purge Control Solenoid Valve.>
7	CHECK PRESSURE CONTROL SOLENOID VALVE. Operate the pressure control solenoid valve. NOTE: Pressure control solenoid valve operation can also be executed using Subaru Select Monitor. For the procedure, refer to "Compulsory Valve Operation Check Mode". <Ref. to EN(H4SO)(diag)-45, Compulsory Valve Operation Check Mode.>	Does the pressure control solenoid valve operate?	Go to step 8.	Replace the pressure control solenoid valve. <Ref. to EC(H4SO)-6, Purge Control Solenoid Valve.>

Diagnostic Procedure with Diagnostic Trouble Code (DTC)

ENGINE (DIAGNOSTICS)

Step	Check	Yes	No
8 CHECK CANISTER.	Is the canister damaged?	Repair or replace the canister. <Ref. to EC(H4SO)-5, Canister.>	Go to step 9 .
9 CHECK FUEL TANK. Remove the fuel tank. <Ref. to FU(H4SO)-48, Fuel Tank.>	Is the fuel tank damaged?	Repair or replace the fuel tank. <Ref. to FU(H4SO)-48, Fuel Tank.>	Go to step 10 .
10 CHECK ANY OTHER MECHANICAL TROUBLE IN EVAPORATIVE EMISSION CONTROL SYSTEM.	Are there holes of more than 0.5 mm (0.020 in) dia., cracks, clogging or disconnections of hoses or pipes in evaporative emission control system?	Repair or replace the hoses or pipes.	Contact SOA Service Center. NOTE: Inspection by DTM is required, because probable cause is deterioration of multiple parts.

Diagnostic Procedure with Diagnostic Trouble Code (DTC)

ENGINE (DIAGNOSTICS)

BC:DTC P0458 EVAPORATIVE EMISSION CONTROL SYSTEM PURGE CONTROL VALVE CIRCUIT LOW

DTC DETECTING CONDITION:

- Two consecutive driving cycles with fault
- GENERAL DESCRIPTION <Ref. to GD(H4SO)-141, DTC P0458 EVAPORATIVE EMISSION CONTROL SYSTEM PURGE CONTROL VALVE CIRCUIT LOW, Diagnostic Trouble Code (DTC) Detecting Criteria.>

TROUBLE SYMPTOM:

Erroneous idling

CAUTION:

After repair or replacement of faulty parts, conduct Clear Memory Mode <Ref. to EN(H4SO)(diag)-44, OPERATION, Clear Memory Mode.> and Inspection Mode <Ref. to EN(H4SO)(diag)-37, OPERATION, Inspection Mode.>.

WIRING DIAGRAM:

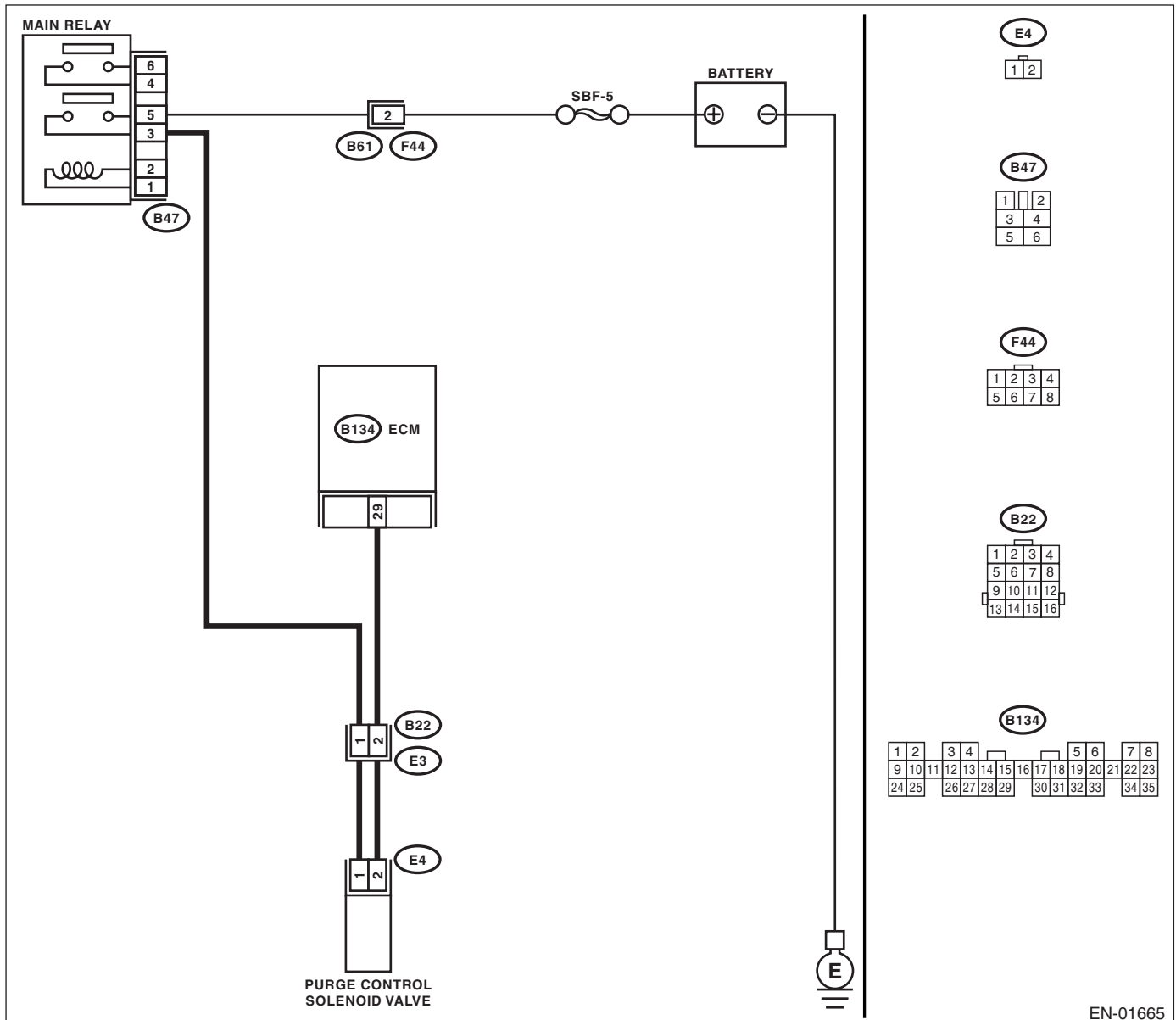

Diagnostic Procedure with Diagnostic Trouble Code (DTC)

ENGINE (DIAGNOSTICS)

Step	Check	Yes	No
1 CHECK OUTPUT SIGNAL FROM ECM. 1) Turn the ignition switch to ON. 2) Measure the voltage between ECM and chassis ground. Connector & terminal (B134) No. 29 (+) — Chassis ground (-):	Is the voltage more than 10 V?	Even if malfunction indicator light lights up, the circuit has returned to a normal condition at this time. Contact SOA Service Center. NOTE: Inspection by DTM is required, because probable cause is deterioration of multiple parts.	Go to step 2.
2 CHECK HARNESS BETWEEN PURGE CONTROL SOLENOID VALVE AND ECM CONNECTOR. 1) Turn the ignition switch to OFF. 2) Disconnect the connectors from purge control solenoid valve and ECM. 3) Measure the resistance of harness between purge control solenoid valve connector and engine ground. Connector & terminal (E4) No. 2 — Engine ground:	Is the resistance more than 1 M Ω ?	Go to step 3.	Repair ground short circuit in harness between ECM and purge control solenoid valve connector.
3 CHECK HARNESS BETWEEN PURGE CONTROL SOLENOID VALVE AND ECM CONNECTOR. Measure the resistance of harness between ECM and purge control solenoid valve of harness connector. Connector & terminal (B134) No. 29 — (E4) No. 2:	Is the resistance less than 1 Ω ?	Go to step 4.	Repair open circuit in harness between ECM and purge control solenoid valve connector. NOTE: In this case, repair the following: • Open circuit in harness between ECM and purge control solenoid valve connector • Poor contact in coupling connector
4 CHECK PURGE CONTROL SOLENOID VALVE. 1) Remove the purge control solenoid valve. 2) Measure the resistance between purge control solenoid valve terminals. Terminals No. 1 — No. 2:	Is the resistance 10 — 100 Ω ?	Go to step 5.	Replace the purge control solenoid valve. <Ref. to EC(H4SO)-6, Purge Control Solenoid Valve.>
5 CHECK POWER SUPPLY TO PURGE CONTROL SOLENOID VALVE. 1) Turn the ignition switch to ON. 2) Measure the voltage between purge control solenoid valve and engine ground. Connector & terminal (E4) No. 1 (+) — Engine ground (-):	Is the voltage more than 10 V?	Go to step 6.	Repair open circuit in harness between main relay and purge control solenoid valve connector.

Diagnostic Procedure with Diagnostic Trouble Code (DTC)

ENGINE (DIAGNOSTICS)

	Step	Check	Yes	No
6	CHECK POOR CONTACT. Check poor contact in purge control solenoid valve connector.	Is there poor contact in purge control solenoid valve connector?	Repair poor contact in purge control solenoid valve connector.	Contact SOA Service Center. NOTE: Inspection by DTM is required, because probable cause is deterioration of multiple parts.

Diagnostic Procedure with Diagnostic Trouble Code (DTC)

ENGINE (DIAGNOSTICS)

BD:DTC P0459 EVAPORATIVE EMISSION CONTROL SYSTEM PURGE CONTROL VALVE CIRCUIT HIGH

DTC DETECTING CONDITION:

- Two consecutive driving cycles with fault
- GENERAL DESCRIPTION <Ref. to GD(H4SO)-143, DTC P0459 EVAPORATIVE EMISSION CONTROL SYSTEM PURGE CONTROL VALVE CIRCUIT HIGH, Diagnostic Trouble Code (DTC) Detecting Criteria.>

TROUBLE SYMPTOM:

Erroneous idling

CAUTION:

After repair or replacement of faulty parts, conduct Clear Memory Mode <Ref. to EN(H4SO)(diag)-44, OPERATION, Clear Memory Mode.> and Inspection Mode <Ref. to EN(H4SO)(diag)-37, OPERATION, Inspection Mode.>.

WIRING DIAGRAM:

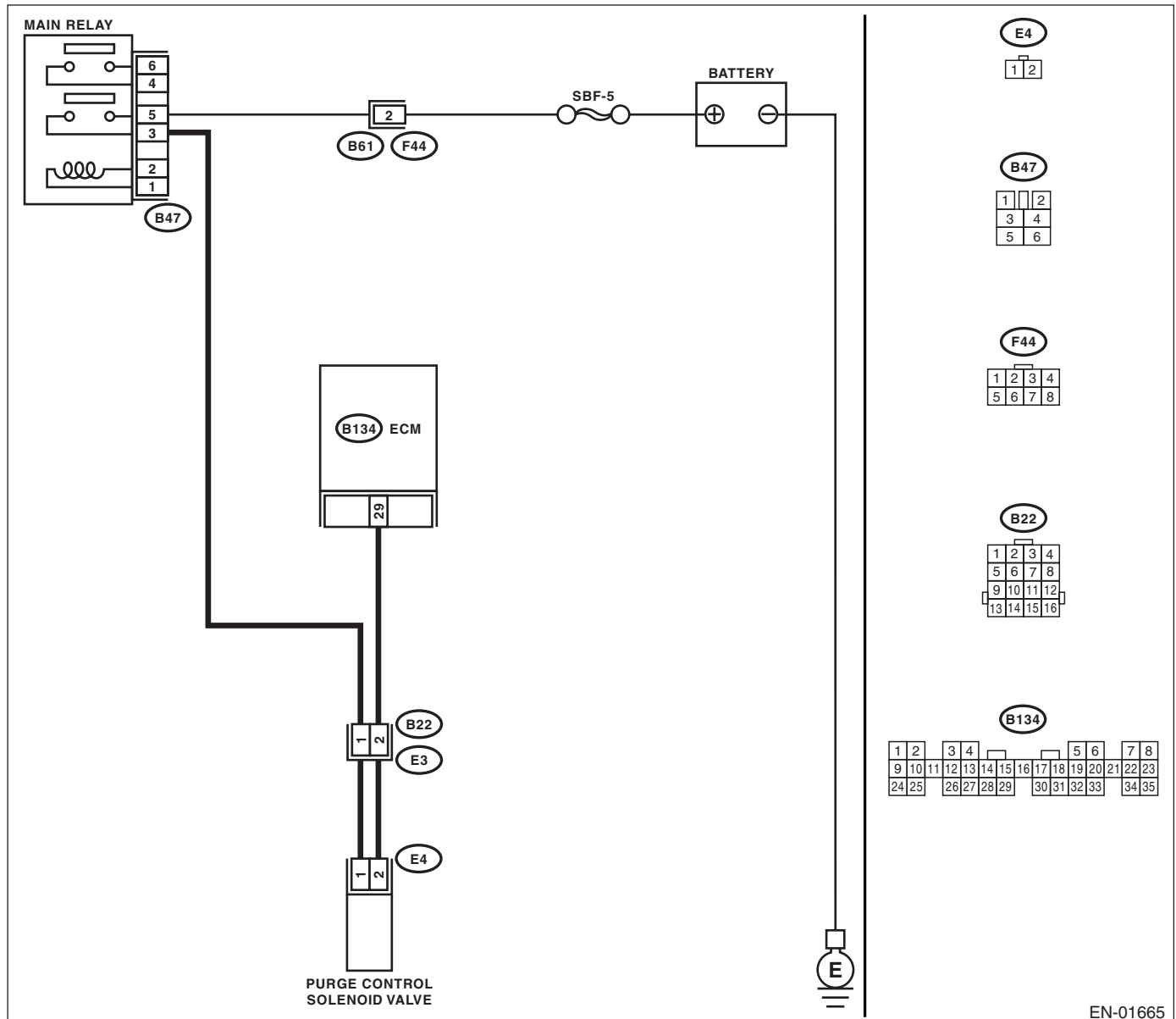

EN-01665

Diagnostic Procedure with Diagnostic Trouble Code (DTC)

ENGINE (DIAGNOSTICS)

Step	Check	Yes	No
1 CHECK OUTPUT SIGNAL FROM ECM. 1) Turn the ignition switch to OFF. 2) Connect the test mode connector at the lower portion of instrument panel (on the driver's side). 3) Turn the ignition switch to ON. 4) While operating the purge control solenoid valve, measure voltage between ECM and chassis ground. NOTE: Purge control solenoid valve operation can be executed using Subaru Select Monitor. For procedure, refer to "Compulsory Valve Operation Check Mode". <Ref. to EN(H4SO)(diag)-45, Compulsory Valve Operation Check Mode.> Connector & terminal (B134) No. 29 (+) — Chassis ground (-):	Is the voltage 0 — 10 V?	Go to step 2.	Even if malfunction indicator light light up, the circuit has returned to a normal condition at this time. In this case, repair poor contact in ECM connector.
2 CHECK OUTPUT SIGNAL FROM ECM. 1) Turn the ignition switch to ON. 2) Measure the voltage between ECM and chassis ground. Connector & terminal (B134) No. 29 (+) — Chassis ground (-):	Is the voltage more than 10 V?	Go to step 4.	Go to step 3.
3 CHECK POOR CONTACT. Check poor contact in ECM connector.	Is there poor contact in ECM connector?	Repair poor contact in ECM connector.	Replace the ECM. <Ref. to FU(H4SO)-44, Engine Control Module (ECM).>
4 CHECK HARNESS BETWEEN PURGE CONTROL SOLENOID VALVE AND ECM CONNECTOR. 1) Turn the ignition switch to OFF. 2) Disconnect the connector from purge control solenoid valve. 3) Turn the ignition switch to ON. 4) Measure the voltage between ECM and chassis ground. Connector & terminal (B134) No. 29 (+) — Chassis ground (-):	Is the voltage more than 10 V?	Repair battery short circuit in harness between ECM and purge control solenoid valve connector. After repair, replace the ECM. <Ref. to FU(H4SO)-44, Engine Control Module (ECM).>	Go to step 5.
5 CHECK PURGE CONTROL SOLENOID VALVE. 1) Turn the ignition switch to OFF. 2) Measure the resistance between purge control solenoid valve terminals. Terminals No. 1 — No. 2:	Is the resistance less than 1 Ω ?	Replace the purge control solenoid valve <Ref. to EC(H4SO)-6, Purge Control Solenoid Valve.> and ECM <Ref. to FU(H4SO)-44, Engine Control Module (ECM).>	Go to step 6.
6 CHECK POOR CONTACT. Check poor contact in ECM connector.	Is there poor contact in ECM connector?	Repair poor contact in ECM connector.	Replace the ECM. <Ref. to FU(H4SO)-44, Engine Control Module (ECM).>

Diagnostic Procedure with Diagnostic Trouble Code (DTC)

ENGINE (DIAGNOSTICS)

Step	Check	Yes	No
1 CHECK FOR OTHER DTC ON DISPLAY.	Is any other DTC displayed?	Inspect DTC using "List of Diagnostic Trouble Code (DTC)". <Ref. to EN(H4SO)(diag)-71, List of Diagnostic Trouble Code (DTC).> NOTE: In this case, it is not necessary to inspect this trouble.	Replace the fuel level sensor <Ref. to FU(H4SO)-57, Fuel Level Sensor.> and fuel sub level sensor. <Ref. to FU(H4SO)-57, Fuel Level Sensor.>

Diagnostic Procedure with Diagnostic Trouble Code (DTC)

ENGINE (DIAGNOSTICS)

BF:DTC P0462 FUEL LEVEL SENSOR CIRCUIT LOW INPUT

DTC DETECTING CONDITION:

- Two consecutive driving cycles with fault
- GENERAL DESCRIPTION <Ref. to GD(H4SO)-147, DTC P0462 FUEL LEVEL SENSOR CIRCUIT LOW INPUT, Diagnostic Trouble Code (DTC) Detecting Criteria.>

CAUTION:

After repair or replacement of faulty parts, conduct Clear Memory Mode <Ref. to EN(H4SO)(diag)-44, OPERATION, Clear Memory Mode.> and Inspection Mode <Ref. to EN(H4SO)(diag)-37, OPERATION, Inspection Mode.>.

WIRING DIAGRAM:

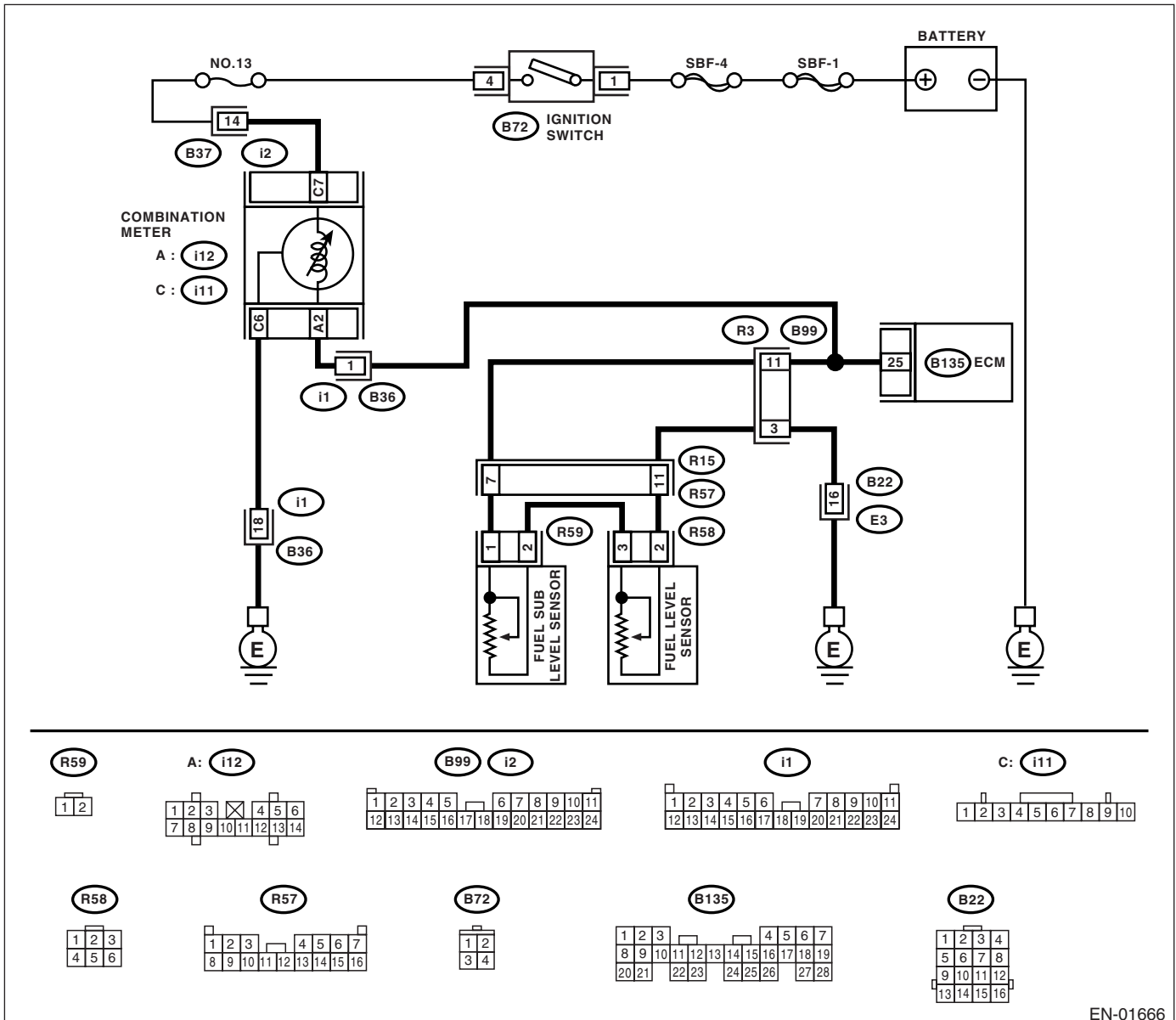

EN-01666

Diagnostic Procedure with Diagnostic Trouble Code (DTC)

ENGINE (DIAGNOSTICS)

Step	Check	Yes	No
1	CHECK SPEEDOMETER AND TACHOMETER OPERATION IN COMBINATION METER.	Go to step 2.	Repair or replace the combination meter. <Ref. to IDI-3, Combination Meter System.>
2	CHECK INPUT SIGNAL FOR ECM. 1) Turn the ignition switch to ON. (Engine OFF) 2) Measure the voltage between ECM connector and chassis ground. Connector & terminal (B135) No. 25 (+) — Chassis ground (-):	Go to step 4.	Go to step 3.
3	CHECK INPUT SIGNAL FOR ECM. (USING SUBARU SELECT MONITOR.) Read the data of fuel level sensor signal using Subaru Select Monitor. NOTE: • Subaru Select Monitor For detailed operation procedure, refer to the "READ CURRENT DATA FOR ENGINE". <Ref. to EN(H4SO)(diag)-30, Subaru Select Monitor.>	Is the voltage less than 0.12 V by shaking the harness and connector of ECM?	Repair poor contact in ECM connector. Even if malfunction indicator light lights up, the circuit has returned to a normal condition at this time. A temporary poor contact of the connector may be the cause. NOTE: In this case, repair the following: • Poor contact in combination meter connector • Poor contact in ECM connector • Poor contact in coupling connectors
4	CHECK INPUT VOLTAGE OF ECM. 1) Turn the ignition switch to OFF. 2) Separate fuel tank cord connector (R57) and rear wiring harness connector (R15). 3) Turn the ignition switch to ON. 4) Measure the voltage of harness between ECM connector and chassis ground. Connector & terminal (B135) No. 25 (+) — Chassis ground (-):	Is the voltage more than 0.12 V?	Go to step 5. Go to step 6.
5	CHECK HARNESS BETWEEN ECM AND COMBINATION METER. 1) Turn the ignition switch to OFF. 2) Disconnect the connector from connector (i12) and ECM connector. 3) Measure the resistance between ECM and chassis ground. Connector & terminal (B135) No. 25 — Chassis ground:	Is the resistance more than 1 MΩ?	Go to step 7. Repair ground short circuit in harness between ECM and combination meter connector.
6	CHECK HARNESS BETWEEN ECM AND COMBINATION METER. Measure the resistance between ECM and combination meter connector. Connector & terminal (B135) No. 25 — (i12) No. 2:	Is the resistance less than 10 Ω?	Repair or replace the combination meter. <Ref. to IDI-3, Combination Meter System.> Repair open circuit between ECM and combination meter connector. NOTE: In this case, repair the following: Poor contact in coupling connector

Diagnostic Procedure with Diagnostic Trouble Code (DTC)

ENGINE (DIAGNOSTICS)

Step	Check	Yes	No
7 CHECK FUEL TANK CORD. 1) Turn ignition switch to OFF. 2) Disconnect the connector from fuel sub level sensor. 3) Measure the resistance between fuel sub level sensor and chassis ground. Connector & terminal (R59) No. 1 — Chassis ground:	Is the resistance more than 1 MΩ?	Go to step 8.	Repair short circuit to ground in fuel tank cord.
8 CHECK FUEL TANK CORD. 1) Disconnect the connector from fuel pump assembly. 2) Measure the resistance between fuel pump assembly and chassis ground. Connector & terminal (R59) No. 2 — Chassis ground:	Is the resistance more than 1 MΩ?	Go to step 9.	Repair ground short circuit in fuel tank cord.
9 CHECK FUEL LEVEL SENSOR. 1) Remove the fuel pump assembly. <Ref. to FU(H4SO)-55, Fuel Pump.> 2) Measure the resistance between fuel level sensor and terminals with its float set to the full position. Terminals No. 3 — No. 2:	Is the resistance 0.5 — 2.5 Ω?	Go to step 10.	Replace the fuel level sensor.
10 CHECK FUEL SUB LEVEL SENSOR. 1) Remove the fuel sub level sensor. <Ref. to FU(H4SO)-58, Fuel Sub Level Sensor.> 2) Measure the resistance between fuel sub level sensor and terminals with its float set to the full position. Terminals No. 1 — No. 2:	Is the resistance 0.5 — 2.5 Ω?	Repair poor contact in harness between ECM and combination meter connector.	Replace the fuel sub level sensor.

Diagnostic Procedure with Diagnostic Trouble Code (DTC)

ENGINE (DIAGNOSTICS)

BG:DTC P0463 FUEL LEVEL SENSOR CIRCUIT HIGH INPUT

DTC DETECTING CONDITION:

- Two consecutive driving cycles with fault
- GENERAL DESCRIPTION <Ref. to GD(H4SO)-149, DTC P0463 FUEL LEVEL SENSOR CIRCUIT HIGH INPUT, Diagnostic Trouble Code (DTC) Detecting Criteria.>

CAUTION:

After repair or replacement of faulty parts, conduct Clear Memory Mode <Ref. to EN(H4SO)(diag)-44, OPERATION, Clear Memory Mode.> and Inspection Mode <Ref. to EN(H4SO)(diag)-37, OPERATION, Inspection Mode.>.

WIRING DIAGRAM:

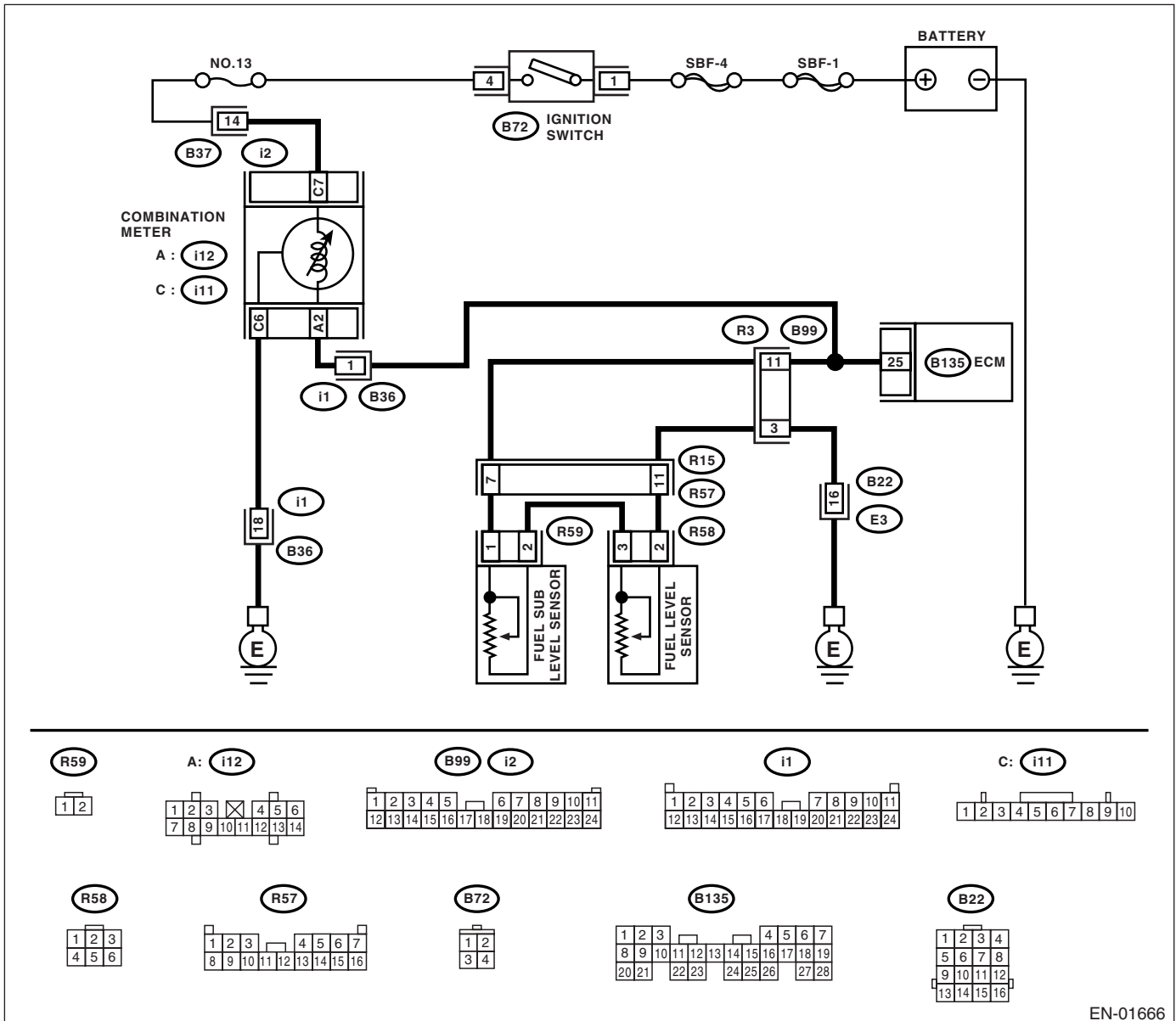

EN-01666

Diagnostic Procedure with Diagnostic Trouble Code (DTC)

ENGINE (DIAGNOSTICS)

Step	Check	Yes	No
1	CHECK SPEEDOMETER AND TACHOMETER OPERATION IN COMBINATION METER.	Go to step 2.	Repair or replace the combination meter. <Ref. to IDI-3, Combination Meter System.>
2	CHECK INPUT SIGNAL FOR ECM. 1) Turn the ignition switch to ON. (Engine OFF) 2) Measure the voltage between ECM connector and chassis ground. Connector & terminal (B135) No. 25 (+) — Chassis ground (-):	Go to step 3.	Even if malfunction indicator light lights up, the circuit has returned to a normal condition at this time. A temporary poor contact of the connector may be the cause. NOTE: In this case, repair the following: <ul style="list-style-type: none"> • Poor contact in fuel pump connector • Poor contact in coupling connector
3	CHECK INPUT VOLTAGE OF ECM. 1) Turn the ignition switch to OFF. 2) Disconnect the combination meter connector (i12) and ECM connector. 3) Turn the ignition switch to ON. 4) Measure the voltage of harness between ECM and chassis ground. Connector & terminal (B135) No. 25 (+) — Chassis ground (-):	Go to step 4.	Repair battery short circuit between ECM and combination meter connector.
4	CHECK HARNESS BETWEEN ECM AND FUEL TANK CORD. 1) Turn the ignition switch to OFF. 2) Separate fuel tank cord connector (R57) and rear wiring harness connector (R15). 3) Measure the resistance between ECM and fuel tank cord. Connector & terminal (B135) No. 25 — (R15) No. 7:	Go to step 5.	Repair open circuit between ECM and fuel tank cord.
5	CHECK HARNESS BETWEEN FUEL TANK CORD AND CHASSIS GROUND. Measure the resistance between fuel tank cord and chassis ground. Connector & terminal (R15) No. 11 — Chassis ground:	Go to step 6.	Repair open circuit between fuel tank cord and chassis ground. NOTE: In this case, repair the following: Poor contact in coupling connectors
6	CHECK FUEL TANK CORD. 1) Disconnect the connector from fuel level sensor. 2) Measure the resistance between fuel level sensor and coupling connector. Connector & terminal (R57) No. 11 — (R58) No. 2:	Go to step 7.	Repair open circuit between coupling connector and fuel level sensor.

Diagnostic Procedure with Diagnostic Trouble Code (DTC)

ENGINE (DIAGNOSTICS)

Step	Check	Yes	No
7 CHECK FUEL TANK CORD. 1) Disconnect the connector from fuel sub level sensor. 2) Measure the resistance between fuel level sensor and fuel sub level sensor. Connector & terminal (R58) No. 3 — (R59) No. 2:	Is the resistance less than 10 Ω ?	Go to step 8.	Repair open circuit between fuel level sensor and fuel sub level sensor.
8 CHECK FUEL TANK CORD. Measure the resistance between fuel level sensor and coupling connector. Connector & terminal (R57) No. 7 — (R59) No. 1:	Is the resistance less than 10 Ω ?	Go to step 9.	Repair open circuit between coupling connector and fuel level sensor.
9 CHECK FUEL LEVEL SENSOR. 1) Remove the fuel pump assembly. <Ref. to FU(H4SO)-55, Fuel Pump.> 2) While moving the fuel level sensor float up and down, measure resistance between fuel level sensor terminals. Terminals No. 3 — No. 2:	Is the resistance more than 54.5 Ω ?	Replace the fuel level sensor. <Ref. to FU(H4SO)-57, Fuel Level Sensor.>	Go to step 10.
10 CHECK FUEL SUB LEVEL SENSOR. 1) Remove the fuel sub level sensor. <Ref. to FU(H4SO)-58, Fuel Sub Level Sensor.> 2) While moving the fuel sub level sensor float up and down, measure resistance between fuel sub level sensor terminals. Terminals No. 1 — No. 2:	Is the resistance more than 41.5 Ω ?	Replace the fuel sub level sensor. <Ref. to FU(H4SO)-58, Fuel Sub Level Sensor.>	Replace the combination meter. <Ref. to IDI-10, Combination Meter Assembly.>

Diagnostic Procedure with Diagnostic Trouble Code (DTC)

ENGINE (DIAGNOSTICS)

BH:DTC P0464 FUEL LEVEL SENSOR CIRCUIT INTERMITTENT

DTC DETECTING CONDITION:

- Two consecutive driving cycles with fault
- GENERAL DESCRIPTION <Ref. to GD(H4SO)-151, DTC P0464 FUEL LEVEL SENSOR CIRCUIT INTERMITTENT, Diagnostic Trouble Code (DTC) Detecting Criteria.>

CAUTION:

After repair or replacement of faulty parts, conduct CLEAR MEMORY MODE <Ref. to EN(H4SO)(diag)-44, OPERATION, Clear Memory Mode.> and INSPECTION MODE <Ref. to EN(H4SO)(diag)-37, OPERATION, Inspection Mode.>.

WIRING DIAGRAM:

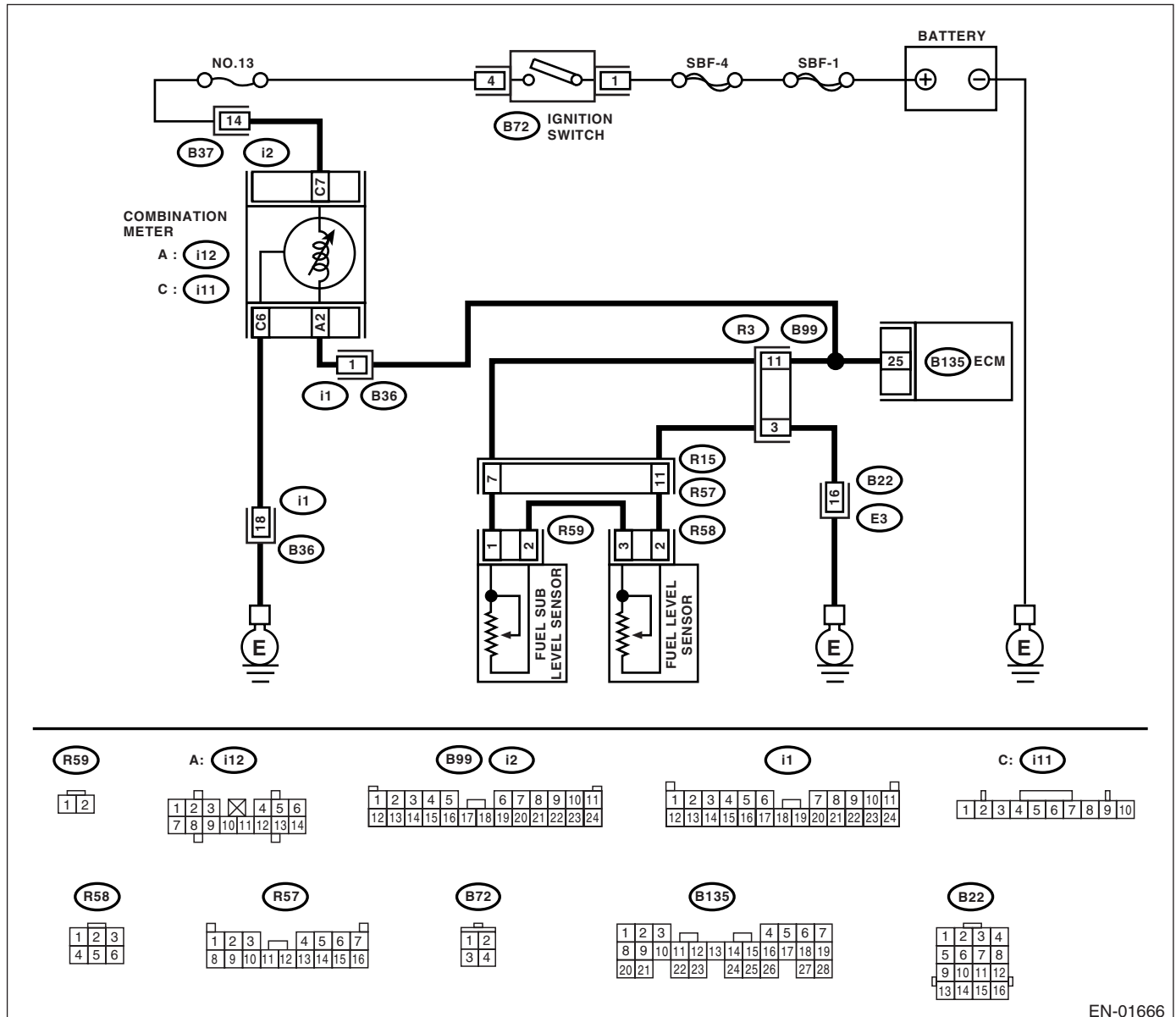

EN-01666

Diagnostic Procedure with Diagnostic Trouble Code (DTC)

ENGINE (DIAGNOSTICS)

Step	Check	Yes	No
1 CHECK FOR OTHER DTC ON DISPLAY.	Is any other DTC displayed?	Inspect DTC P0462 or P0463 using "List of Diagnostic Trouble Code (DTC)". <Ref. to EN(H4SO)(diag)-71, List of Diagnostic Trouble Code (DTC).>	Go to step 2.
2 CHECK FUEL LEVEL SENSOR. 1) Remove the fuel pump assembly. <Ref. to FU(H4SO)-55, Fuel Pump.> 2) While moving the fuel level sensor float up and down, make sure that the resistance between fuel level sensor terminals changes smoothly. Terminals No. 3 — No. 2:	Does the resistance change smoothly?	Go to step 3.	Replace the fuel level sensor. <Ref. to FU(H4SO)-57, Fuel Level Sensor.>
3 CHECK FUEL SUB LEVEL SENSOR. 1) Remove the fuel sub level sensor. <Ref. to FU(H4SO)-57, Fuel Level Sensor.> 2) While moving the fuel sub level sensor float up and down, make sure that the resistance between fuel level sensor terminals changes smoothly. Terminals No. 1 — No. 2:	Does the resistance change smoothly?	Repair poor contact in ECM, combination meter and coupling connectors.	Replace the fuel sub level sensor. <Ref. to FU(H4SO)-57, Fuel Level Sensor.>

BI: DTC P0483 COOLING FAN RATIONALITY CHECK

DTC DETECTING CONDITION:

- Two consecutive driving cycles with fault
- GENERAL DESCRIPTION <Ref. to GD(H4SO)-154, DTC P0483 COOLING FAN RATIONALITY CHECK, Diagnostic Trouble Code (DTC) Detecting Criteria.>

TROUBLE SYMPTOM:

- Occurrence of noise
- Overheating

CAUTION:

After repair or replacement of faulty parts, conduct Clear Memory Mode <Ref. to EN(H4SO)(diag)-44, OPERATION, Clear Memory Mode.> and Inspection Mode <Ref. to EN(H4SO)(diag)-37, OPERATION, Inspection Mode.>.

NOTE:

If the vehicle, with the engine idling, is placed very close to a wall or another vehicle, preventing normal cooling function, the OBD system may detect malfunction.

Diagnostic Procedure with Diagnostic Trouble Code (DTC)

ENGINE (DIAGNOSTICS)

WIRING DIAGRAM:

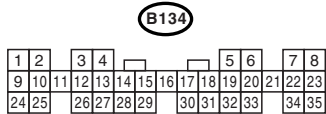
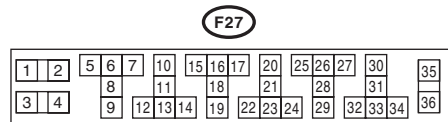
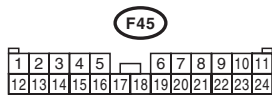
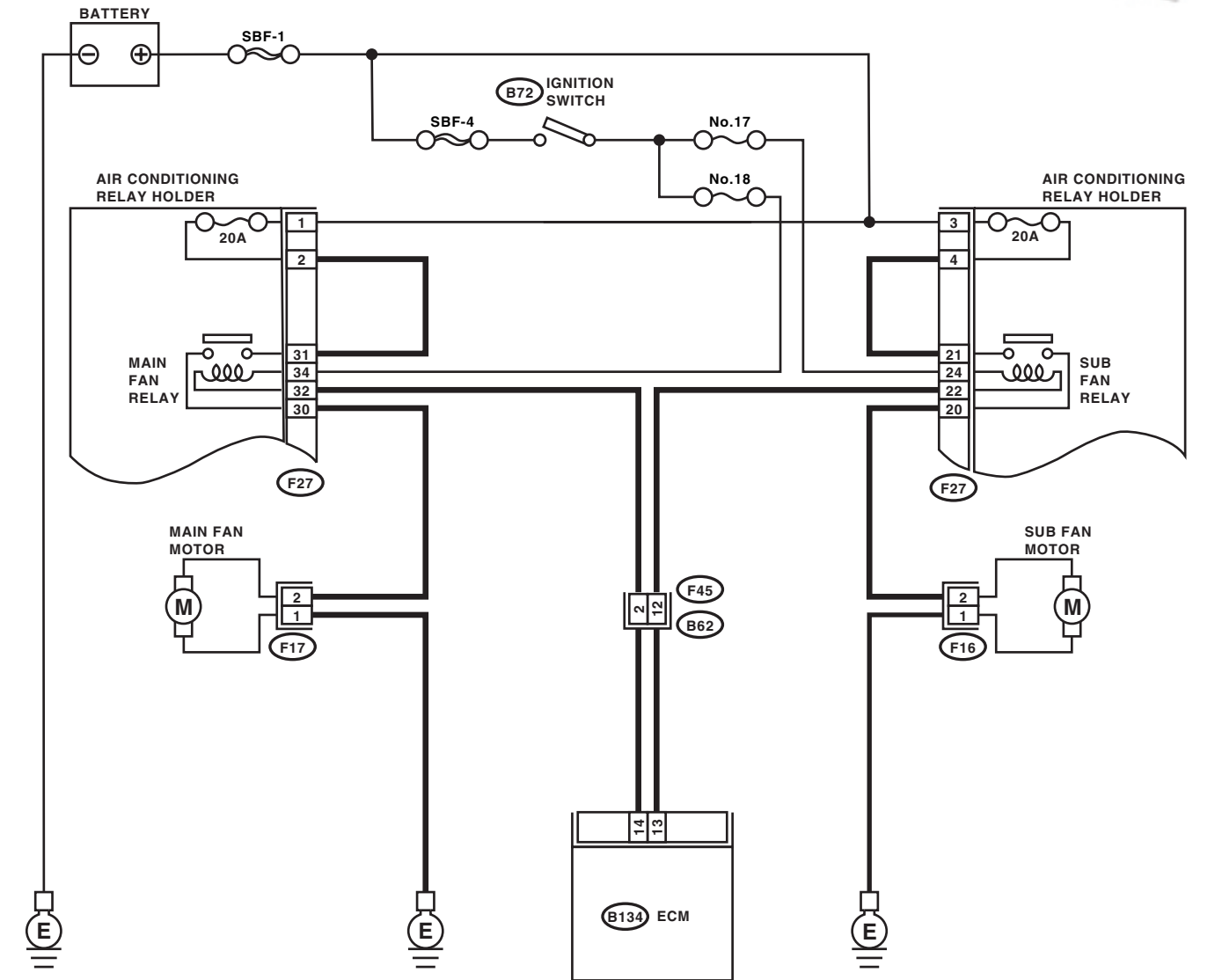

EN-01667

Diagnostic Procedure with Diagnostic Trouble Code (DTC)

ENGINE (DIAGNOSTICS)

Step	Check	Yes	No
1 CHECK ANY OTHER DTC ON DISPLAY.	Is any other DTC displayed?	Inspect the relevant DTC using "List of Diagnostic Trouble Code (DTC)". <Ref. to EN(H4SO)(diag)-71, List of Diagnostic Trouble Code (DTC).>	Check radiator fan and fan motor. <Ref. to CO(H4SO)-22, Radiator Main Fan and Fan Motor.> and <Ref. to CO(H4SO)-23, Radiator Sub Fan and Fan Motor.>

BJ:DTC P0502 VEHICLE SPEED SENSOR CIRCUIT LOW INPUT

NOTE:

For the diagnostic procedure, refer to DTC P0503. <Ref. to EN(H4SO)(diag)-217, DTC P0503 VEHICLE SPEED SENSOR INTERMITTENT/ERRATIC/HIGH, Diagnostic Procedure with Diagnostic Trouble Code (DTC).>

Diagnostic Procedure with Diagnostic Trouble Code (DTC)

ENGINE (DIAGNOSTICS)

BK:DTC P0503 VEHICLE SPEED SENSOR INTERMITTENT/ERRATIC/HIGH

DTC DETECTING CONDITION:

- Immediately at fault recognition
- GENERAL DESCRIPTION <Ref. to GD(H4SO)-157, DTC P0503 VEHICLE SPEED SENSOR INTERMITTENT/ERRATIC/HIGH, Diagnostic Trouble Code (DTC) Detecting Criteria.>

CAUTION:

After repair or replacement of faulty parts, conduct Clear Memory Mode <Ref. to EN(H4SO)(diag)-44, OPERATION, Clear Memory Mode.> and Inspection Mode <Ref. to EN(H4SO)(diag)-37, OPERATION, Inspection Mode.>.

WIRING DIAGRAM:

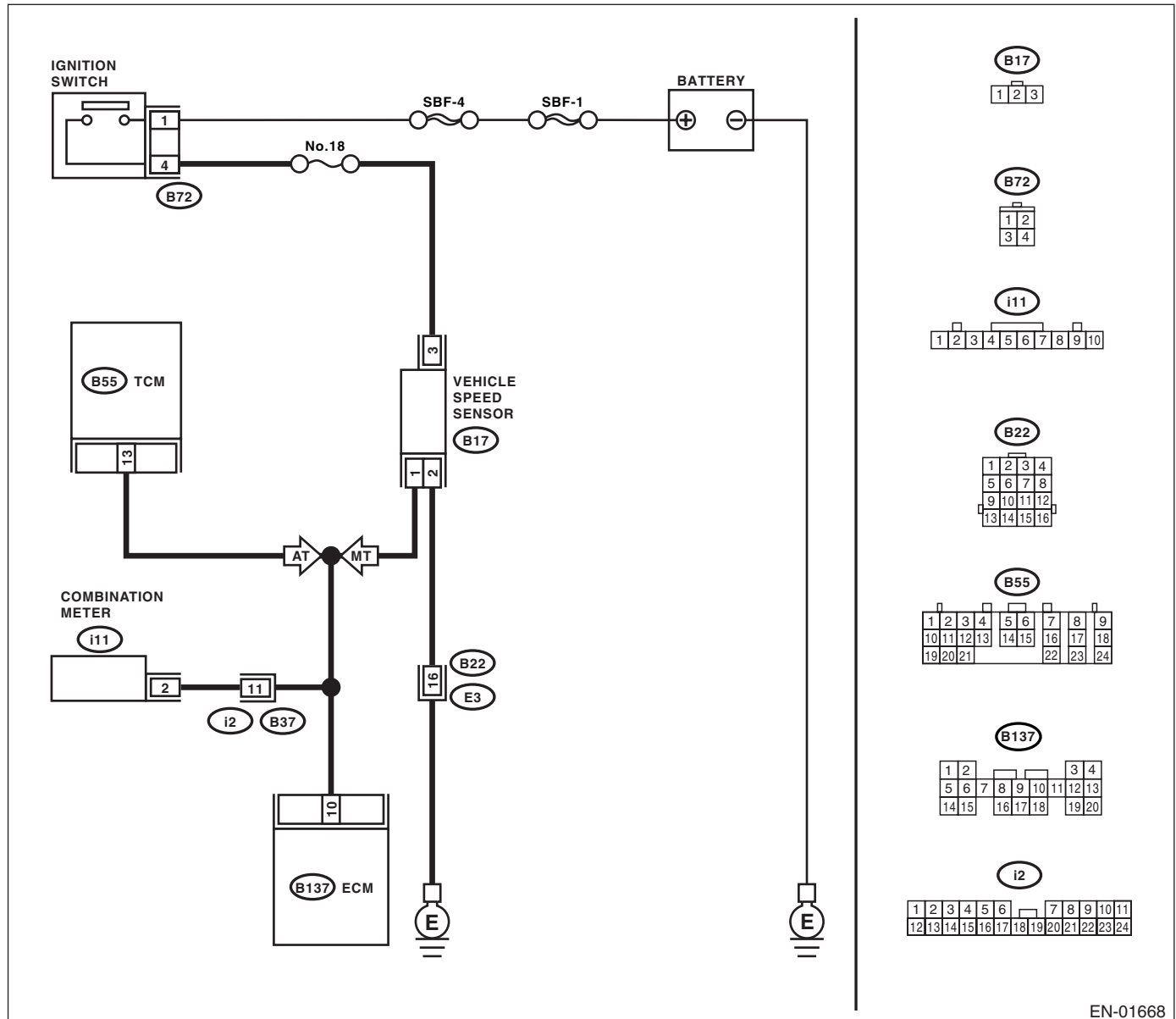

EN-01668

Diagnostic Procedure with Diagnostic Trouble Code (DTC)

ENGINE (DIAGNOSTICS)

Step	Check	Yes	No
1	CHECK TRANSMISSION TYPE.	Is the target AT model?	Go to step 2.
2	CHECK DTC P0720 ON DISPLAY.	Does the Subaru Select Monitor or OBD-II general scan tool indicate DTC P0720?	Go to step 3.
3	CHECK SPEEDOMETER OPERATION IN COMBINATION METER.	Does the speedometer operate normally?	Go to step 4.
4	CHECK HARNESS BETWEEN ECM AND COMBINATION METER CONNECTOR. 1) Turn the ignition switch to OFF. 2) Disconnect the connector from combination meter. 3) Measure the resistance between ECM and combination meter. Connector & terminal (B137) No. 10 — (i11) No. 2:	Is the resistance less than 10 Ω?	Repair poor contact in ECM connector.
			Check speedometer and vehicle speed sensor. <Ref. to IDI-14, Speedometer.> and <Ref. to 4AT-49, Front Vehicle Speed Sensor.> and <Ref. to 4AT-53, Rear Vehicle Speed Sensor.> and <Ref. to 4AT-54, Torque Converter Turbine Speed Sensor.>
			Repair harness and connector. NOTE: In this case, repair the following: • Open circuit in harness between ECM and combination meter connector • Poor contact in ECM connector • Poor contact in combination meter connector • Poor contact in coupling connector

Diagnostic Procedure with Diagnostic Trouble Code (DTC)

ENGINE (DIAGNOSTICS)

BL:DTC P0506 IDLE CONTROL SYSTEM RPM LOWER THAN EXPECTED

DTC DETECTING CONDITION:

- Two consecutive driving cycles with fault
- GENERAL DESCRIPTION <Ref. to GD(H4SO)-158, DTC P0506 IDLE CONTROL SYSTEM RPM LOWER THAN EXPECTED, Diagnostic Trouble Code (DTC) Detecting Criteria.>

TROUBLE SYMPTOM:

- Engine is difficult to start.
- Engine does not start.
- Erroneous idling
- Engine stalls.

CAUTION:

After repair or replacement of faulty parts, conduct Clear Memory Mode <Ref. to EN(H4SO)(diag)-44, OPERATION, Clear Memory Mode.> and Inspection Mode <Ref. to EN(H4SO)(diag)-37, OPERATION, Inspection Mode.>.

WIRING DIAGRAM:

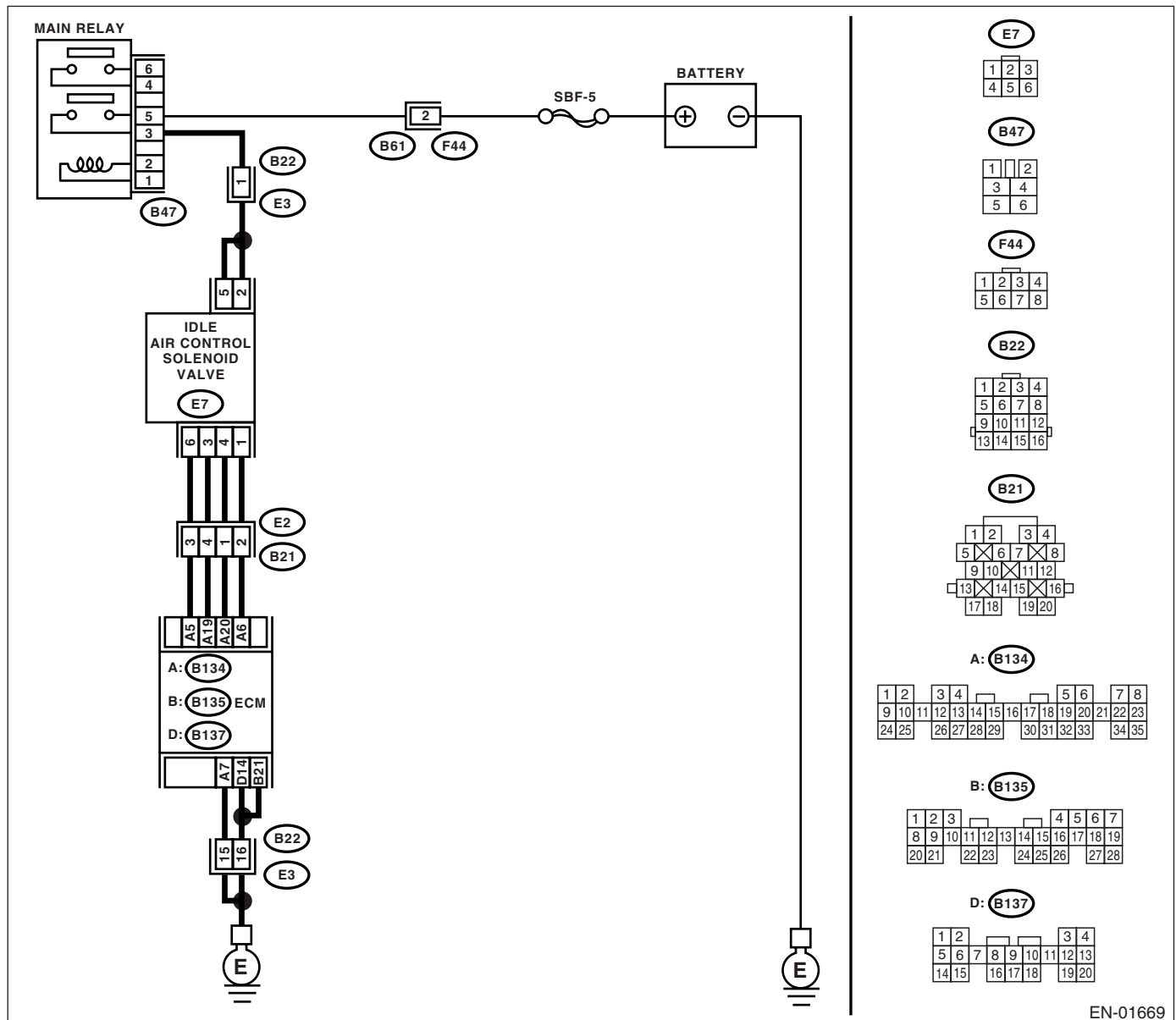

EN-01669

Diagnostic Procedure with Diagnostic Trouble Code (DTC)

ENGINE (DIAGNOSTICS)

	Step	Check	Yes	No
1	CHECK ANY OTHER DTC ON DISPLAY.	Is any other DTC displayed?	Inspect DTC using "List of Diagnostic Trouble Code (DTC)". <Ref. to EN(H4SO)(diag)-71, List of Diagnostic Trouble Code (DTC).> NOTE: In this case, it is not necessary to inspect DTC P0506.	Go to step 2.
2	CHECK AIR BY-PASS LINE. 1) Turn the ignition switch to OFF. 2) Remove the idle air control solenoid valve from throttle body. <Ref. to FU(H4SO)-32, REMOVAL, Idle Air Control Solenoid Valve.> 3) Remove the throttle body from intake manifold. <Ref. to FU(H4SO)-12, REMOVAL, Throttle Body.> 4) Using an air gun, force air into the idle air control solenoid valve installation area. Confirm that forced air subsequently escapes from throttle body interior.	Does air flow out?	Replace the idle air control solenoid valve. <Ref. to FU(H4SO)-32, INSTALLATION, Idle Air Control Solenoid Valve.>	Replace the throttle body. <Ref. to FU(H4SO)-12, INSTALLATION, Throttle Body.>

Diagnostic Procedure with Diagnostic Trouble Code (DTC)

ENGINE (DIAGNOSTICS)

BM:DTC P0507 IDLE CONTROL SYSTEM RPM HIGHER THAN EXPECTED

DTC DETECTING CONDITION:

- Two consecutive driving cycles with fault
- GENERAL DESCRIPTION <Ref. to GD(H4SO)-160, DTC P0507 IDLE CONTROL SYSTEM RPM HIGHER THAN EXPECTED, Diagnostic Trouble Code (DTC) Detecting Criteria.>

TROUBLE SYMPTOM:

Engine keeps running at higher revolution than specified idling revolution.

CAUTION:

After repair or replacement of faulty parts, conduct Clear Memory Mode <Ref. to EN(H4SO)(diag)-44, OPERATION, Clear Memory Mode.> and Inspection Mode <Ref. to EN(H4SO)(diag)-37, OPERATION, Inspection Mode.>.

WIRING DIAGRAM:

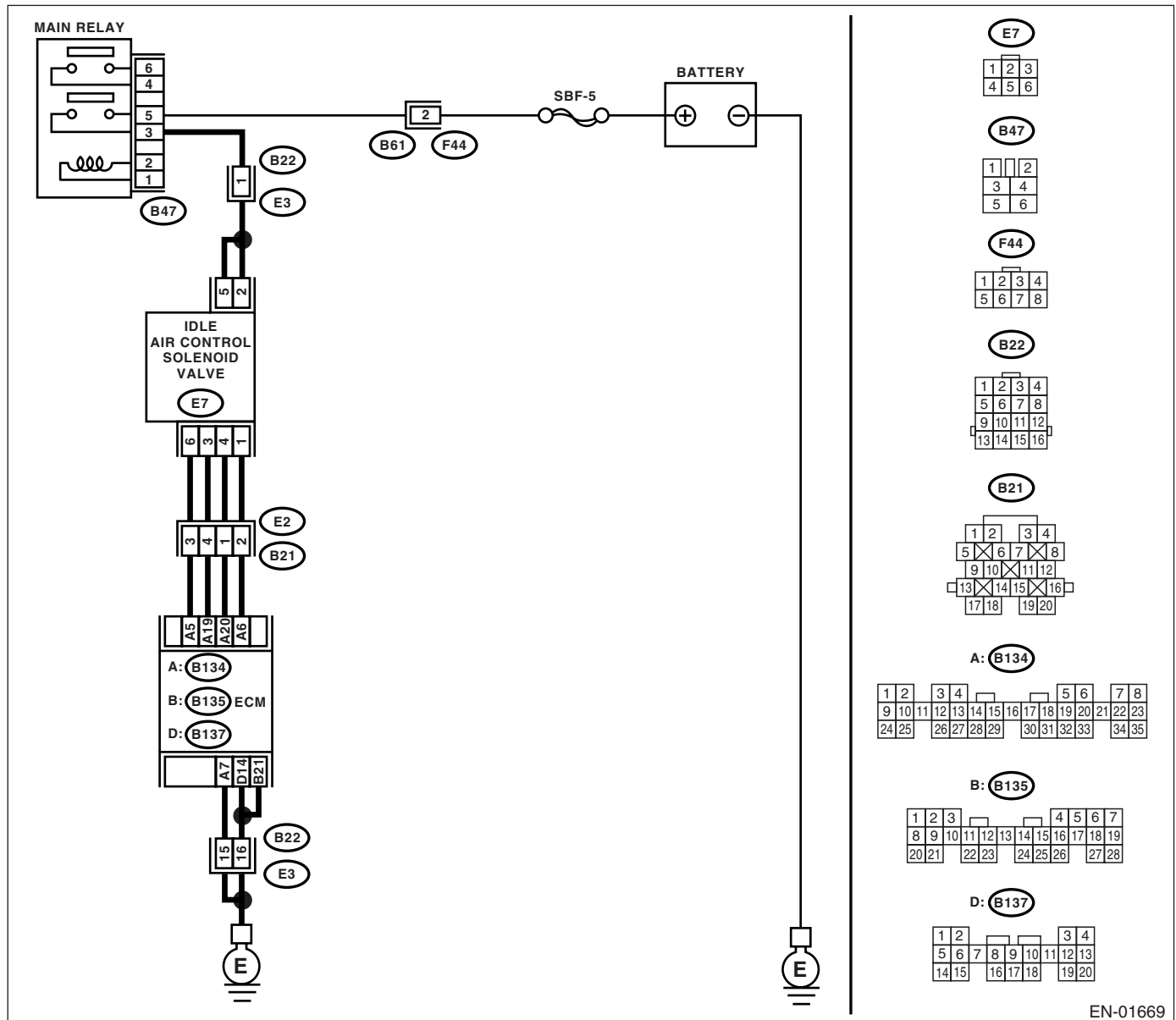

EN-01669

Diagnostic Procedure with Diagnostic Trouble Code (DTC)

ENGINE (DIAGNOSTICS)

Step	Check	Yes	No
1 CHECK ANY OTHER DTC ON DISPLAY.	Is any other DTC displayed?	Inspect DTC using "List of Diagnostic Trouble Code (DTC)". <Ref. to EN(H4SO)(diag)-71, List of Diagnostic Trouble Code (DTC).> NOTE: In this case, it is not necessary to inspect DTC P0507.	Go to step 2.
2 CHECK AIR INTAKE SYSTEM. 1) Turn the ignition switch to ON. 2) Start the engine, and idle it. 3) Check the following items. • Loose installation of intake manifold, idle air control solenoid valve and throttle body • Cracks of intake manifold gasket, idle air control solenoid valve gasket and throttle body gasket • Disconnections of vacuum hoses	Is there a fault in air intake system?	Repair air suction and leaks.	Go to step 3.
3 CHECK THROTTLE CABLE.	Is throttle cable play correct?	Go to step 4.	Adjust throttle cable. <Ref. to SP(H4SO)-6, INSTALLATION, Accelerator Control Cable.>
4 CHECK AIR BY-PASS LINE. 1) Turn the ignition switch to OFF. 2) Remove the idle air control solenoid valve from throttle body. <Ref. to FU(H4SO)-32, REMOVAL, Idle Air Control Solenoid Valve.> 3) Confirm that there are no foreign particles in air by-pass line.	Is air by-pass line clogged by foreign particles?	Remove foreign particles from air by-pass line.	Replace the idle air control solenoid valve. <Ref. to FU(H4SO)-32, INSTALLATION, Idle Air Control Solenoid Valve.>

BN:DTC P0512 STARTER REQUEST CIRCUIT

DTC DETECTING CONDITION:

- Two consecutive driving cycles with fault
- GENERAL DESCRIPTION <Ref. to GD(H4SO)-162, DTC P0512 STARTER REQUEST CIRCUIT, Diagnostic Trouble Code (DTC) Detecting Criteria.>

TROUBLE SYMPTOM:

Failure of engine to start

CAUTION:

After repair or replacement of faulty parts, conduct Clear Memory Mode <Ref. to EN(H4SO)(diag)-44, OPERATION, Clear Memory Mode.> and Inspection Mode <Ref. to EN(H4SO)(diag)-37, OPERATION, Inspection Mode.>.

Diagnostic Procedure with Diagnostic Trouble Code (DTC)

ENGINE (DIAGNOSTICS)

WIRING DIAGRAM:

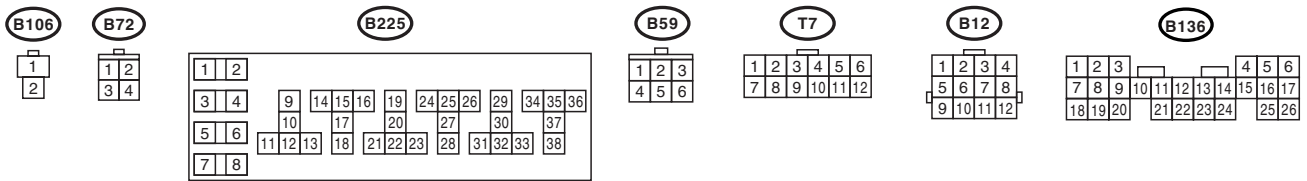
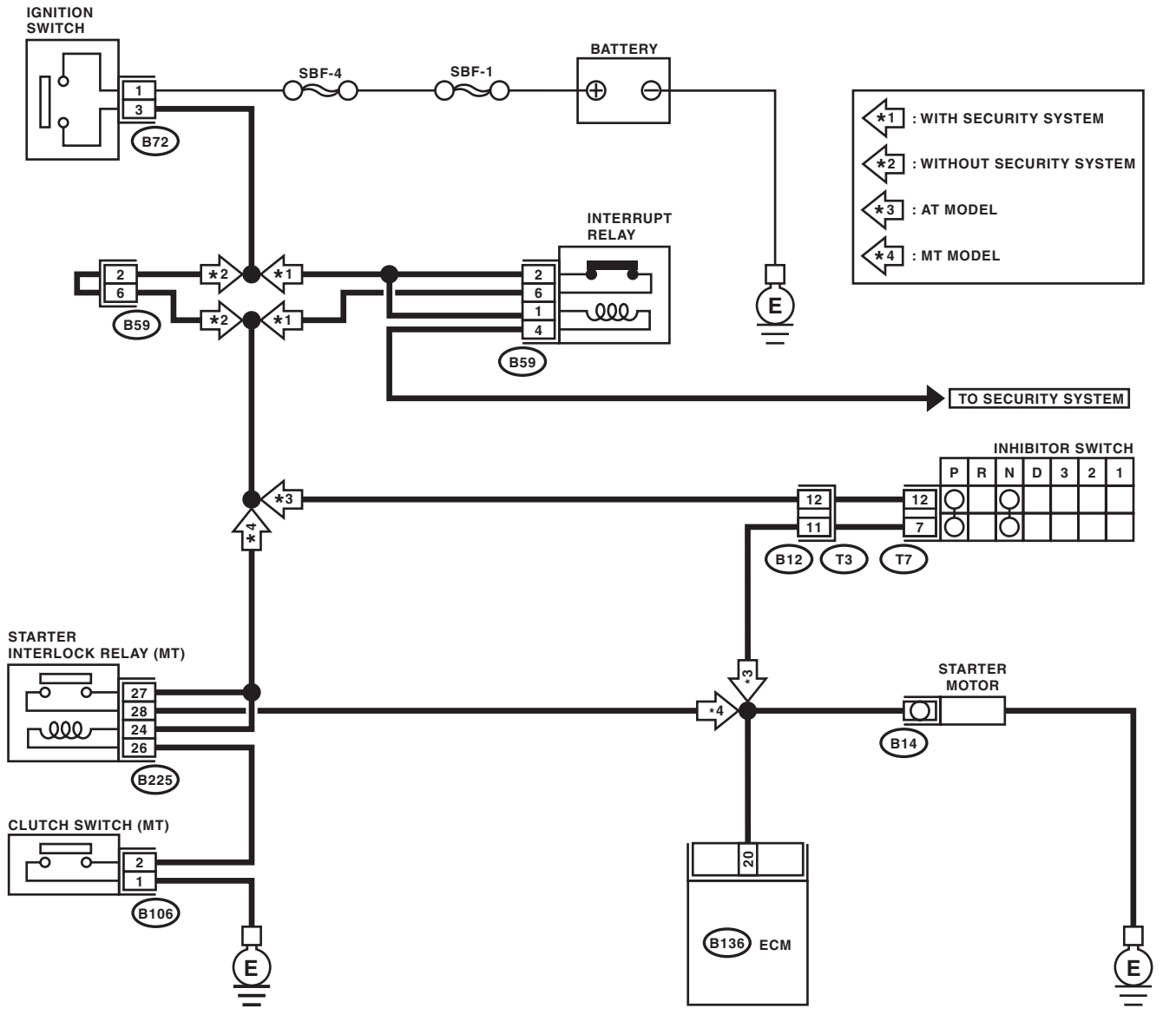

EN-01645

Diagnostic Procedure with Diagnostic Trouble Code (DTC)

ENGINE (DIAGNOSTICS)

Step	Check	Yes	No
1 CHECK OPERATION OF STARTER MOTOR. Turn the ignition switch to ON. NOTE: Place the inhibitor switch in each position. (AT model) Depress or release the clutch pedal. (MT model)	Does the starter motor operate?	Repair battery short circuit in starter motor circuit.	Check starter motor circuit. <Ref. to EN(H4SO)(diag)-57, STARTER MOTOR CIRCUIT, Diagnostics for Engine Starting Failure.>

Diagnostic Procedure with Diagnostic Trouble Code (DTC)

ENGINE (DIAGNOSTICS)

BO:DTC P0519 IDLE CONTROL SYSTEM MALFUNCTION (FAIL-SAFE)

DTC DETECTING CONDITION:

- Immediately at fault recognition
- GENERAL DESCRIPTION <Ref. to GD(H4SO)-163, DTC P0519 IDLE CONTROL SYSTEM MALFUNCTION (FAIL-SAFE), Diagnostic Trouble Code (DTC) Detecting Criteria.>

TROUBLE SYMPTOM:

Engine keeps running at higher revolution than specified idling revolution.

CAUTION:

After repair or replacement of faulty parts, conduct Clear Memory Mode <Ref. to EN(H4SO)(diag)-44, OPERATION, Clear Memory Mode.> and Inspection Mode <Ref. to EN(H4SO)(diag)-37, OPERATION, Inspection Mode.>.

WIRING DIAGRAM:

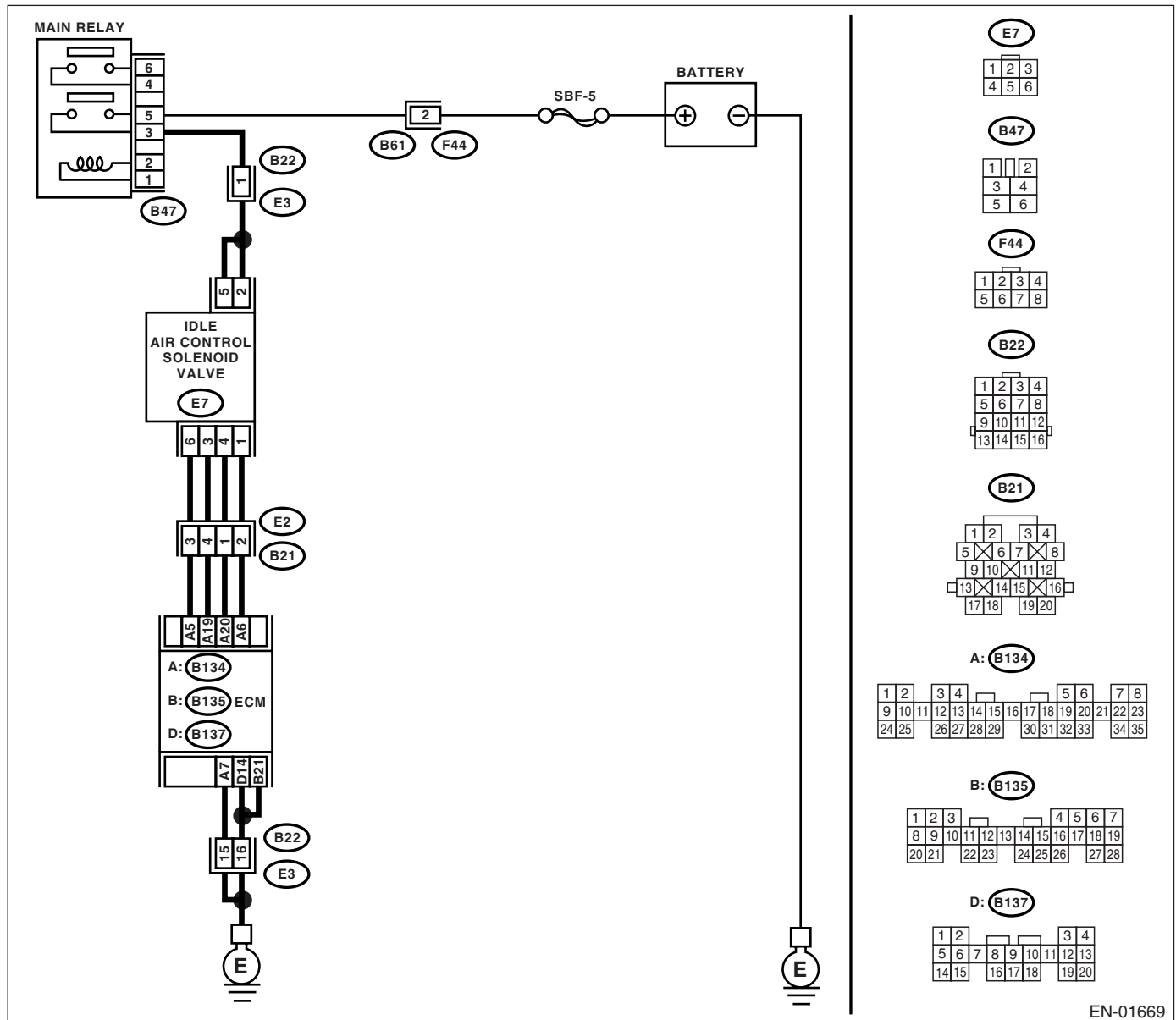

EN-01669

Diagnostic Procedure with Diagnostic Trouble Code (DTC)

ENGINE (DIAGNOSTICS)

Step	Check	Yes	No
1 CHECK ANY OTHER DTC ON DISPLAY.	Is any other DTC displayed?	Inspect DTC using "List of Diagnostic Trouble Code (DTC)". <Ref. to EN(H4SO)(diag)-71, List of Diagnostic Trouble Code (DTC).> NOTE: In this case, it is not necessary to inspect DTC P0519.	Go to step 2.
2 CHECK AIR INTAKE SYSTEM. 1) Turn the ignition switch to ON. 2) Start the engine, and idle it. 3) Check the following items. <ul style="list-style-type: none"> • Loose installation of intake manifold, idle air control solenoid valve and throttle body • Cracks of intake manifold gasket, idle air control solenoid valve gasket and throttle body gasket • Disconnections of vacuum hoses 	Is there a fault in air intake system?	Repair air suction and leaks.	Go to step 3.
3 CHECK THROTTLE CABLE.	Is throttle cable play correct?	Go to step 4.	Adjust throttle cable. <Ref. to SP(H4SO)-6, INSTALLATION, Accelerator Control Cable.>
4 CHECK AIR BY-PASS LINE. 1) Turn the ignition switch to OFF. 2) Remove the idle air control solenoid valve from throttle body. <Ref. to FU(H4SO)-32, Idle Air Control Solenoid Valve.> 3) Confirm that there are no foreign particles in air by-pass line.	Is air by-pass line clogged by foreign particles?	Remove foreign particles from air by-pass line.	Replace the idle air control solenoid valve. <Ref. to FU(H4SO)-32, Idle Air Control Solenoid Valve.>

Diagnostic Procedure with Diagnostic Trouble Code (DTC)

ENGINE (DIAGNOSTICS)

BP:DTC P0565 CRUISE CONTROL ON SIGNAL

DTC DETECTING CONDITION:

- Two consecutive driving cycles with fault
- GENERAL DESCRIPTION <Ref. to GD(H4SO)-164, DTC P0565 CRUISE CONTROL ON SIGNAL, Diagnostic Trouble Code (DTC) Detecting Criteria.>

CAUTION:

After repair or replacement of faulty parts, conduct Clear Memory Mode <Ref. to EN(H4SO)(diag)-44, OPERATION, Clear Memory Mode.> and Inspection Mode <Ref. to EN(H4SO)(diag)-37, OPERATION, Inspection Mode.>.

WIRING DIAGRAM:

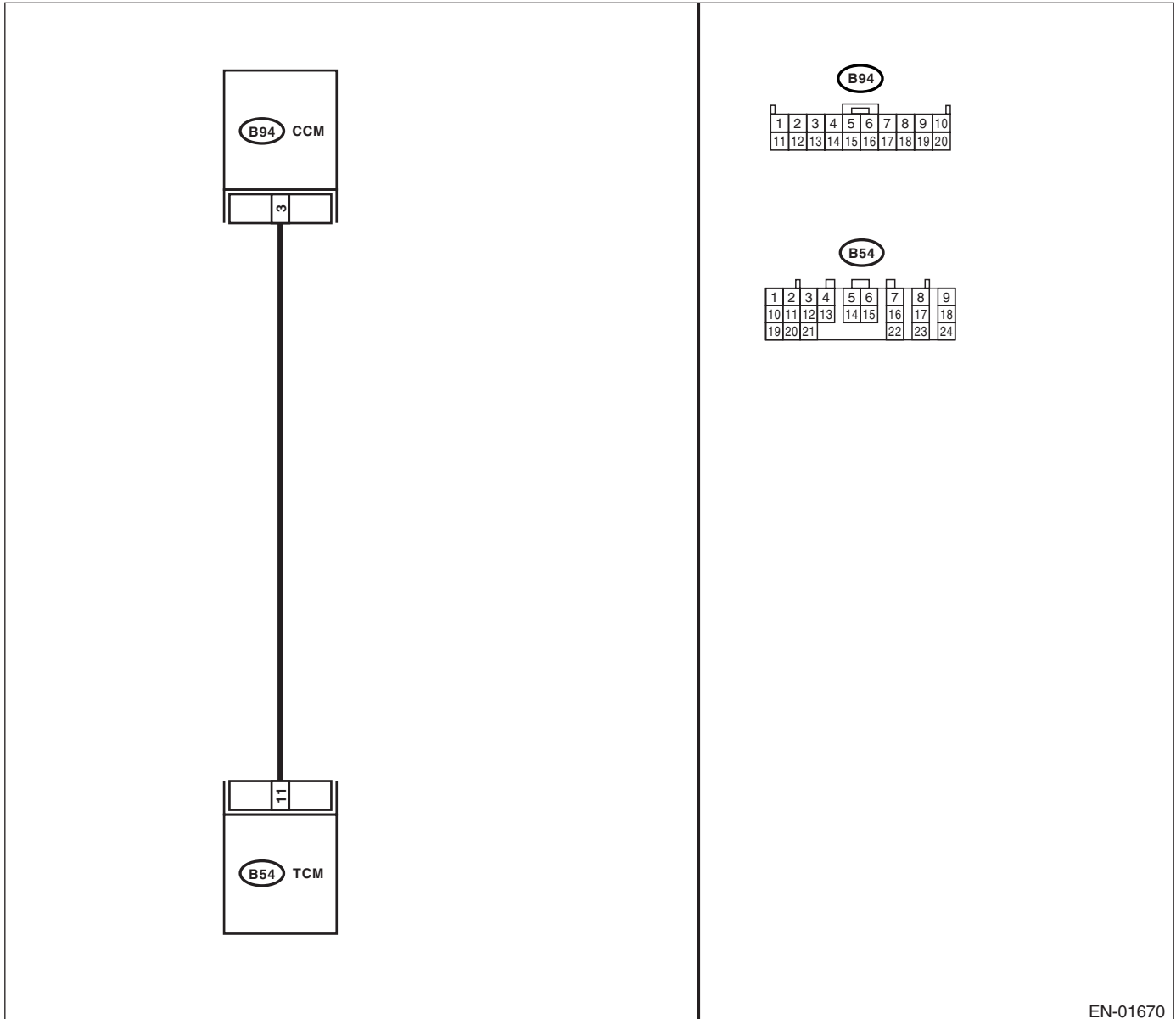

EN-01670

Diagnostic Procedure with Diagnostic Trouble Code (DTC)

ENGINE (DIAGNOSTICS)

Step	Check	Yes	No
1 CHECK HARNESS BETWEEN TCM AND CCM CONNECTOR. 1) Turn the ignition switch to OFF. 2) Disconnect the connectors from TCM and CCM. 3) Measure the resistance of harness between TCM and CCM connector. Connector & terminal (B54) No. 11— (B94) No. 3:	Is the resistance less than 1 Ω ?	Go to step 2.	Repair open circuit in harness between TCM and CCM connector.
2 CHECK HARNESS BETWEEN TCM AND CCM CONNECTOR. Measure the resistance of harness between TCM and chassis ground. Connector & terminal (B54) No. 11 — Chassis ground:	Is the resistance more than 1 M Ω ?	Go to step 3.	Repair short circuit in harness between TCM and CCM connector.
3 CHECK INPUT SIGNAL FOR TCM. 1) Connect the connector to TCM and CCM. 2) Lift-up the vehicle or set the vehicle on free rollers. CAUTION: On AWD models, raise all wheels off ground. 3) Start the engine. 4) Turn the cruise control main switch to ON. 5) Increase vehicle speed to 50 km/h (31 MPH). 6) Turn the cruise control command switch to ON. 7) Measure the voltage between TCM and chassis ground. Connector & terminal (B54) No. 11 (+) — Chassis ground (-):	Is the voltage less than 1 V?	Go to step 4.	Check cruise control command switch circuit. <Ref. to CC-7, INSPECTION, Cruise Control Command Switch.>
4 CHECK POOR CONTACT. Check poor contact in TCM connector.	Is there poor contact in TCM connector?	Repair poor contact in TCM connector.	Replace the TCM. <Ref. to 4AT-67, Transmission Control Module (TCM).>

Diagnostic Procedure with Diagnostic Trouble Code (DTC)

ENGINE (DIAGNOSTICS)

BQ:DTC P0604 INTERNAL CONTROL MODULE RANDOM ACCESS MEMORY (RAM) ERROR

DTC DETECTING CONDITION:

- Immediately at fault recognition
- GENERAL DESCRIPTION <Ref. to GD(H4SO)-165, DTC P0604 INTERNAL CONTROL MODULE RANDOM ACCESS MEMORY (RAM) ERROR, Diagnostic Trouble Code (DTC) Detecting Criteria.>

TROUBLE SYMPTOM:

- Engine does not start.
- Engine stalls.

CAUTION:

After repair or replacement of faulty parts, conduct Clear Memory Mode <Ref. to EN(H4SO)(diag)-44, OPERATION, Clear Memory Mode.> and Inspection Mode <Ref. to EN(H4SO)(diag)-37, OPERATION, Inspection Mode.>.

WIRING DIAGRAM:

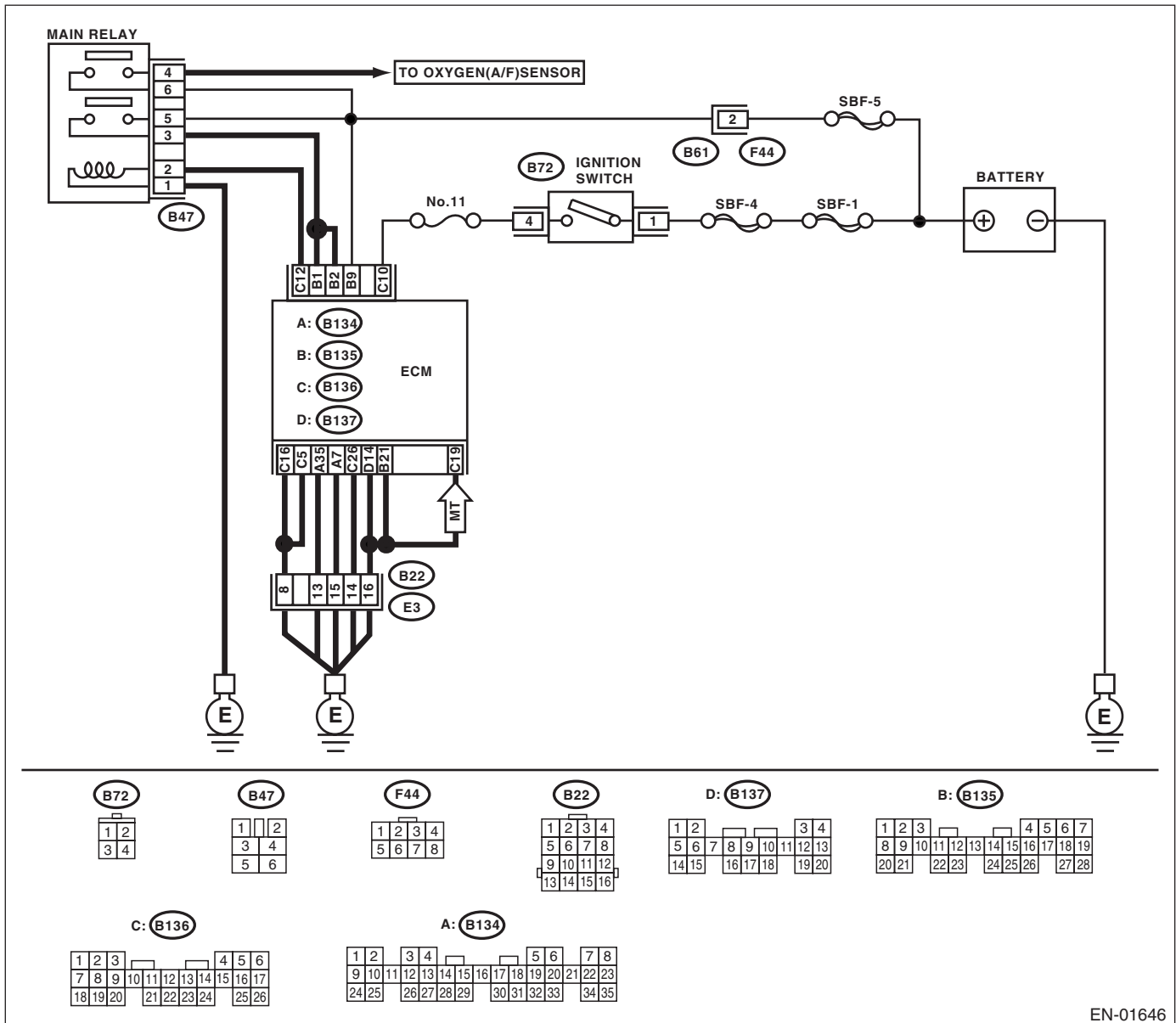

EN-01646

Diagnostic Procedure with Diagnostic Trouble Code (DTC)

ENGINE (DIAGNOSTICS)

Step	Check	Yes	No
1 CHECK ANY OTHER DTC ON DISPLAY.	Is any other DTC displayed?	Check the relevant DTC using the List of Diagnostic Trouble Code (DTC). <Ref. to EN(H4SO)(diag)-71, List of Diagnostic Trouble Code (DTC).>	A temporary poor contact occurs.

BR:DTC P0691 COOLING FAN 1 CONTROL CIRCUIT LOW

DTC DETECTING CONDITION:

- Two consecutive driving cycles with fault
- GENERAL DESCRIPTION <Ref. to GD(H4SO)-166, DTC P0691 COOLING FAN 1 CONTROL CIRCUIT LOW, Diagnostic Trouble Code (DTC) Detecting Criteria.>

TROUBLE SYMPTOM:

- Radiator fan does not operate properly.
- Overheating

CAUTION:

After repair or replacement of faulty parts, conduct Clear Memory Mode <Ref. to EN(H4SO)(diag)-44, OPERATION, Clear Memory Mode.> and Inspection Mode <Ref. to EN(H4SO)(diag)-37, OPERATION, Inspection Mode.>.

Diagnostic Procedure with Diagnostic Trouble Code (DTC)

ENGINE (DIAGNOSTICS)

WIRING DIAGRAM:

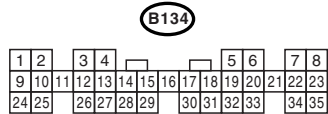
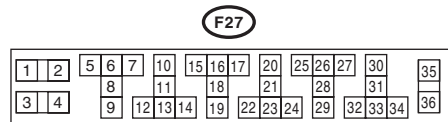
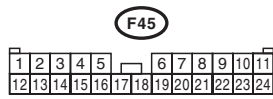
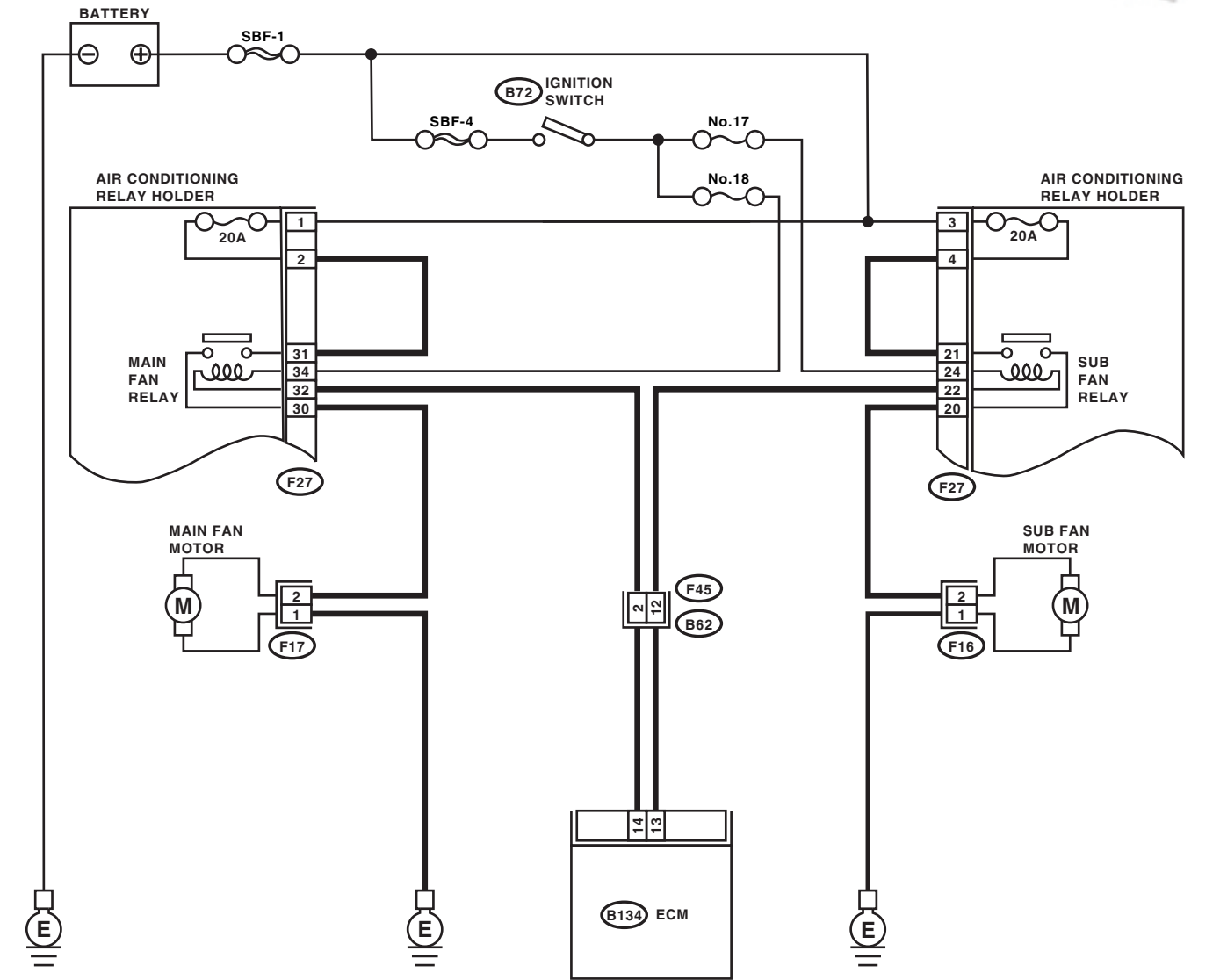

EN-01667

Diagnostic Procedure with Diagnostic Trouble Code (DTC)

ENGINE (DIAGNOSTICS)

Step	Check	Yes	No
<p>1 CHECK OUTPUT SIGNAL FROM ECM. 1) Turn the ignition switch to OFF. 2) Connect the test mode connector at the lower portion of instrument panel (on the driver's side). 3) Turn the ignition switch to ON. 4) While operating the radiator fan relay, measure voltage between ECM terminal and ground.</p> <p>NOTE: Radiator fan relay operation can be executed using Subaru Select Monitor. For procedure, refer to "Compulsory Valve Operation Check Mode". <Ref. to EN(H4SO)(diag)-30, Subaru Select Monitor.></p> <p>Connector & terminal (B134) No. 13 (+) — Chassis ground (-): (B134) No. 14 (+) — Chassis ground (-):</p>	Is the voltage 0 — 10 V?	Repair poor contact in ECM connector.	Go to step 2.
<p>2 CHECK GROUND SHORT CIRCUIT IN RADIATOR FAN RELAY CONTROL CIRCUIT. 1) Turn the ignition switch to OFF. 2) Disconnect the connectors from ECM. 3) Measure the resistance of harness between ECM connector and chassis ground.</p> <p>Connector & terminal (B134) No. 13 — Chassis ground: (B134) No. 14 — Chassis ground:</p>	Is the resistance less than 10 Ω ?	Repair ground short circuit in radiator fan relay control circuit.	Go to step 3.
<p>3 CHECK POWER SUPPLY FOR RELAY. 1) Remove the radiator fan relay from A/C relay holder. 2) Turn the ignition switch to ON. 3) Measure the voltage between fuse and relay box (F/B) connector and chassis ground.</p> <p>Connector & terminal (F27) No. 24 (+) — Chassis ground (-): (F27) No. 34 (+) — Chassis ground (-):</p>	Is the voltage more than 10 V?	Go to step 4.	Repair open circuit in harness between ignition switch and fuse and relay box (F/B) connector.
<p>4 CHECK RADIATOR FAN RELAY. 1) Turn the ignition switch to OFF. 2) Measure the resistance between radiator fan relay terminals.</p> <p>Terminals No. 22 — No. 24: No. 32 — No. 34:</p>	Is the resistance 87 — 107 Ω ?	Go to step 5.	Replace the radiator fan relay.
<p>5 CHECK OPEN CIRCUIT IN RADIATOR FAN RELAY CONTROL CIRCUIT. Measure the resistance of harness between ECM and radiator fan relay connector.</p> <p>Connector & terminal (B134) No. 14 — (F27) No. 32: (B134) No. 13 — (F27) No. 22:</p>	Is the resistance less than 1 Ω ?	Go to step 6.	Repair harness and connector. NOTE: In this case, repair the following: • Open circuit in harness between ECM and radiator fan relay connector • Poor contact in coupling connector
<p>6 CHECK POOR CONTACT. Check poor contact in ECM or radiator fan relay connector.</p>	Is there poor contact in ECM or radiator fan relay connector?	Repair poor contact in ECM or radiator fan relay connector.	Contact SOA Service Center.

Diagnostic Procedure with Diagnostic Trouble Code (DTC)

ENGINE (DIAGNOSTICS)

BS:DTC P0692 COOLING FAN 1 CONTROL CIRCUIT HIGH

DTC DETECTING CONDITION:

- Two consecutive driving cycles with fault
- GENERAL DESCRIPTION <Ref. to GD(H4SO)-167, DTC P0692 COOLING FAN 1 CONTROL CIRCUIT HIGH, Diagnostic Trouble Code (DTC) Detecting Criteria.>

TROUBLE SYMPTOM:

- Radiator fan does not operate properly.
- Overheating

CAUTION:

After repair or replacement of faulty parts, conduct Clear Memory Mode <Ref. to EN(H4SO)(diag)-44, OPERATION, Clear Memory Mode.> and Inspection Mode <Ref. to EN(H4SO)(diag)-37, OPERATION, Inspection Mode.>.

Diagnostic Procedure with Diagnostic Trouble Code (DTC)

ENGINE (DIAGNOSTICS)

WIRING DIAGRAM:

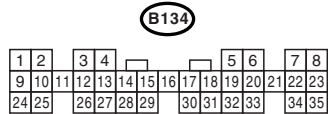
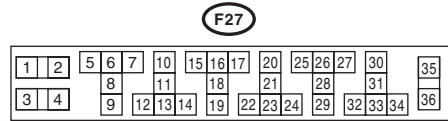
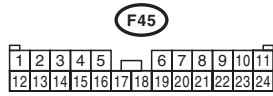
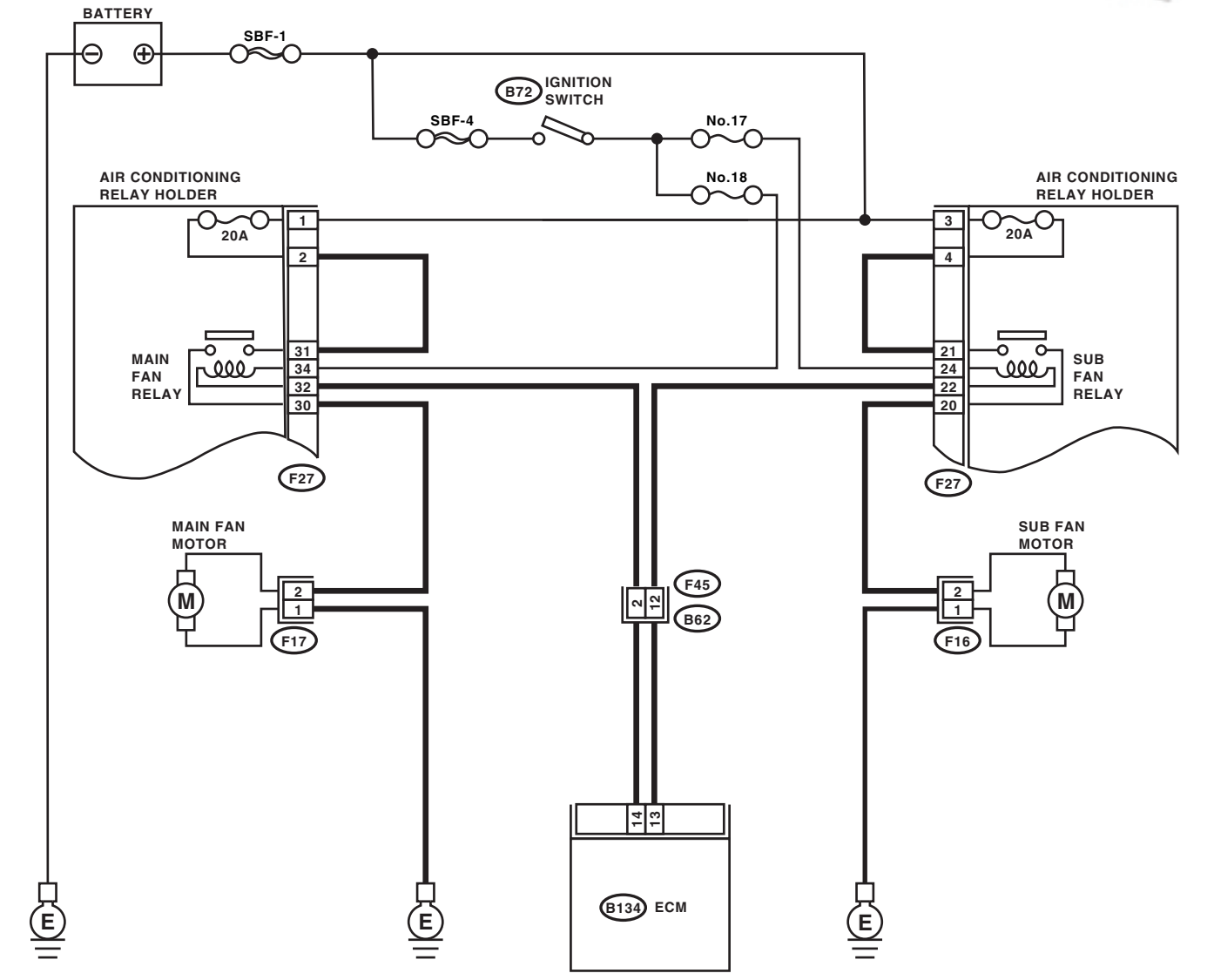

EN-01667

Diagnostic Procedure with Diagnostic Trouble Code (DTC)

ENGINE (DIAGNOSTICS)

Step	Check	Yes	No
<p>1 CHECK OUTPUT SIGNAL FROM ECM.</p> <p>1) Turn the ignition switch to OFF. 2) Connect the test mode connector at the lower portion of instrument panel (on the driver's side). 3) Turn the ignition switch to ON. 4) While operating the radiator fan relay, measure voltage between ECM and chassis ground.</p> <p>NOTE: Radiator fan relay operation can be executed using Subaru Select Monitor. For procedure, refer to "Compulsory Valve Operation Check Mode". <Ref. to EN(H4SO)(diag)-45, Compulsory Valve Operation Check Mode.></p> <p>Connector & terminal (B134) No. 14 (+) — Chassis ground (-): (B134) No. 13 (+) — Chassis ground (-):</p>	<p>Is the voltage 0 — 10 V?</p>	<p>Even if malfunction indicator light lights up, the circuit has returned to a normal condition at this time. In this case, repair poor contact in ECM connector.</p>	<p>Go to step 2.</p>
<p>2 CHECK SHORT CIRCUIT IN RADIATOR FAN RELAY CONTROL CIRCUIT.</p> <p>1) Turn the ignition switch to OFF. 2) Remove the main fan relay and sub fan relay. (with A/C models) 3) Disconnect the test mode connector. 4) Turn the ignition switch to ON. 5) Measure the voltage between ECM and chassis ground.</p> <p>Connector & terminal (B134) No. 14 (+) — Chassis ground (-): (B134) No. 13 (+) — Chassis ground (-):</p>	<p>Is the voltage more than 10 V?</p>	<p>Repair battery short circuit in radiator fan relay control circuit. After repair, replace the ECM. <Ref. to FU(H4SO)-44, Engine Control Module (ECM).></p>	<p>Go to step 3.</p>
<p>3 CHECK MAIN FAN RELAY.</p> <p>1) Turn the ignition switch to OFF. 2) Remove the main fan relay. 3) Measure the resistance between main fan relay terminals.</p> <p>Terminals No. 30 — No. 31:</p>	<p>Is the resistance less than 1 Ω?</p>	<p>Replace the main fan relay and ECM. <Ref. to FU(H4SO)-44, Engine Control Module (ECM).></p>	<p>Go to step 4.</p>
<p>4 CHECK SUB FAN RELAY.</p> <p>1) Remove the sub fan relay. 2) Measure the resistance between sub fan relay terminals.</p> <p>Terminals No. 20 — No. 21:</p>	<p>Is the resistance less than 1 Ω?</p>	<p>Replace the sub fan relay and ECM. <Ref. to FU(H4SO)-44, Engine Control Module (ECM).></p>	<p>Go to step 5.</p>
<p>5 CHECK POOR CONTACT. Check poor contact in ECM connector.</p>	<p>Is there poor contact in ECM connector?</p>	<p>Repair poor contact in ECM connector.</p>	<p>Replace the ECM. <Ref. to FU(H4SO)-44, Engine Control Module (ECM).></p>

Diagnostic Procedure with Diagnostic Trouble Code (DTC)

ENGINE (DIAGNOSTICS)

BT:DTC P0703 TORQUE CONVERTER/BRAKE SWITCH "B" CIRCUIT

DTC DETECTING CONDITION:

- Two consecutive driving cycles with fault
- GENERAL DESCRIPTION <Ref. to GD(H4SO)-168, DTC P0703 TORQUE CONVERTER/BRAKE SWITCH "B" CIRCUIT, Diagnostic Trouble Code (DTC) Detecting Criteria.>

CAUTION:

After repair or replacement of faulty parts, conduct Clear Memory Mode <Ref. to EN(H4SO)(diag)-44, OPERATION, Clear Memory Mode.> and Inspection Mode <Ref. to EN(H4SO)(diag)-37, OPERATION, Inspection Mode.>.

WIRING DIAGRAM:

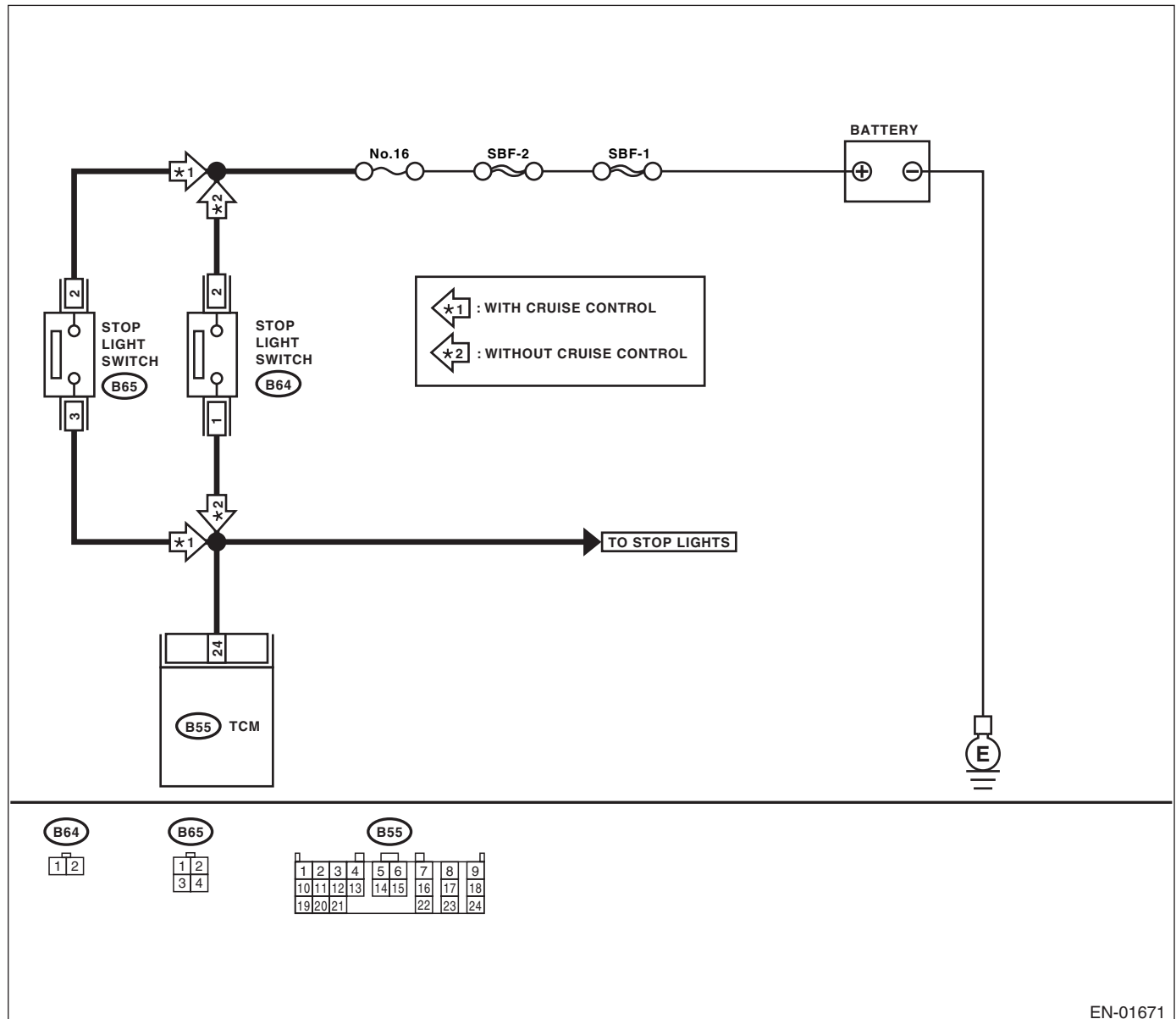

Diagnostic Procedure with Diagnostic Trouble Code (DTC)

ENGINE (DIAGNOSTICS)

Step	Check	Yes	No
1	CHECK OPERATION OF BRAKE LIGHT.	Go to step 2.	Repair or replace the brake light circuit.
2	CHECK HARNESS BETWEEN TCM AND BRAKE LIGHT SWITCH CONNECTOR. 1) Disconnect the connectors from TCM and brake light switch. 2) Measure the resistance of harness between TCM and brake light switch connector. Connector & terminal Without cruise control (B55) No. 24 — (B64) No. 1: With cruise control (B55) No. 24 — (B65) No. 3:	Go to step 3.	Repair or replace the harness and connector. NOTE: In this case, repair the following: • Open circuit in harness between TCM and brake light switch connector • Poor contact in TCM connector • Poor contact in brake light switch connector
3	CHECK HARNESS BETWEEN TCM AND BRAKE LIGHT SWITCH CONNECTOR. Measure the resistance of harness between TCM and chassis ground. Connector & terminal (B55) No. 24 — Chassis ground:	Go to step 4.	Repair ground short circuit in harness between TCM and brake light switch connector.
4	CHECK INPUT SIGNAL FOR TCM. 1) Connect the connectors to TCM and brake light switch. 2) Measure the voltage between TCM and chassis ground. Connector & terminal (B55) No. 24 (+) — Chassis ground (-):	Go to step 5.	Adjust or replace the brake light switch. <Ref. to LI-7, STOP LIGHT SWITCH, INSPECTION, Stop Light System.>
5	CHECK INPUT SIGNAL FOR TCM. Measure the voltage between TCM and chassis ground. Connector & terminal (B55) No. 24 (+) — Chassis ground (-):	Go to step 6.	Adjust or replace the brake light switch. <Ref. to LI-7, STOP LIGHT SWITCH, INSPECTION, Stop Light System.>
6	CHECK POOR CONTACT. Check poor contact in TCM connector.	Repair poor contact in TCM connector.	Replace the TCM. <Ref. to 4AT-67, Transmission Control Module (TCM).>

Diagnostic Procedure with Diagnostic Trouble Code (DTC)

ENGINE (DIAGNOSTICS)

BU:DTC P0705 TRANSMISSION RANGE SENSOR CIRCUIT (PRNDL INPUT)

GENERAL DESCRIPTION <Ref. to GD(H4SO)-169, DTC P0705 TRANSMISSION RANGE SENSOR CIRCUIT (PRNDL INPUT), Diagnostic Trouble Code (DTC) Detecting Criteria.>

NOTE:

Refer to AT-section for diagnostic procedure. <Ref. to 4AT(diag)-104, CHECK INHIBITOR SWITCH, Diagnostic Procedure without Diagnostic Trouble Code (DTC).>

BV:DTC P0710 TRANSMISSION FLUID TEMPERATURE SENSOR CIRCUIT

GENERAL DESCRIPTION <Ref. to GD(H4SO)-170, DTC P0710 TRANSMISSION FLUID TEMPERATURE SENSOR CIRCUIT, Diagnostic Trouble Code (DTC) Detecting Criteria.>

NOTE:

Refer to AT-section for diagnostic procedure. <Ref. to 4AT(diag)-43, DTC 27 ATF TEMPERATURE SENSOR, Diagnostic Procedure with Diagnostic Trouble Code (DTC).>

BW:DTC P0716 OUTPUT/TURBINE SPEED SENSOR CIRCUIT RANGE/PERFORMANCE

GENERAL DESCRIPTION <Ref. to GD(H4SO)-171, DTC P0716 INPUT/TURBINE SPEED SENSOR CIRCUIT RANGE/PERFORMANCE, Diagnostic Trouble Code (DTC) Detecting Criteria.>

NOTE:

Refer to AT-section for diagnostic procedure. <Ref. to 4AT(diag)-57, DTC 36 TORQUE CONVERTER TURBINE SPEED SENSOR, Diagnostic Procedure with Diagnostic Trouble Code (DTC).>

BX:DTC P0720 OUTPUT SPEED SENSOR CIRCUIT

GENERAL DESCRIPTION <Ref. to GD(H4SO)-172, DTC P0720 OUTPUT SPEED SENSOR CIRCUIT, Diagnostic Trouble Code (DTC) Detecting Criteria.>

NOTE:

Refer to AT-section for diagnostic procedure. <Ref. to 4AT(diag)-52, DTC 33 FRONT VEHICLE SPEED SENSOR, Diagnostic Procedure with Diagnostic Trouble Code (DTC).>

BY:DTC P0726 ENGINE SPEED INPUT CIRCUIT RANGE/PERFORMANCE

GENERAL DESCRIPTION <Ref. to GD(H4SO)-173, DTC P0726 ENGINE SPEED INPUT CIRCUIT RANGE/PERFORMANCE, Diagnostic Trouble Code (DTC) Detecting Criteria.>

NOTE:

Refer to AT-section for diagnostic procedure. <Ref. to 4AT(diag)-39, DTC 11 ENGINE SPEED SIGNAL, Diagnostic Procedure with Diagnostic Trouble Code (DTC).>

BZ:DTC P0731 GEAR 1 INCORRECT RATIO

NOTE:

For the diagnostic procedure, refer to DTC P0734. <Ref. to EN(H4SO)(diag)-239, DTC P0734 GEAR 4 INCORRECT RATIO, Diagnostic Procedure with Diagnostic Trouble Code (DTC).>

CA:DTC P0732 GEAR 2 INCORRECT RATIO

NOTE:

For the diagnostic procedure, refer to DTC P0734. <Ref. to EN(H4SO)(diag)-239, DTC P0734 GEAR 4 INCORRECT RATIO, Diagnostic Procedure with Diagnostic Trouble Code (DTC).>

CB:DTC P0733 GEAR 3 INCORRECT RATIO

NOTE:

For the diagnostic procedure, refer to DTC P0734. <Ref. to EN(H4SO)(diag)-239, DTC P0734 GEAR 4 INCORRECT RATIO, Diagnostic Procedure with Diagnostic Trouble Code (DTC).>

Diagnostic Procedure with Diagnostic Trouble Code (DTC)

ENGINE (DIAGNOSTICS)

CC:DTC P0734 GEAR 4 INCORRECT RATIO

DTC DETECTING CONDITION:

- Two consecutive driving cycles with fault
- GENERAL DESCRIPTION <Ref. to GD(H4SO)-177, DTC P0734 GEAR 4 INCORRECT RATIO, Diagnostic Trouble Code (DTC) Detecting Criteria.>

TROUBLE SYMPTOM:

Shift point too high or too low; engine brake not effected in “3” range; excessive shift shock; excessive tight corner “braking”

CAUTION:

After repair or replacement of faulty parts, conduct Clear Memory Mode <Ref. to EN(H4SO)(diag)-44, OPERATION, Clear Memory Mode.> and Inspection Mode <Ref. to EN(H4SO)(diag)-37, OPERATION, Inspection Mode.>.

Step	Check	Yes	No	
1	CHECK ANY OTHER DTC ON DISPLAY.	Is any other DTC displayed?	Inspect relevant DTC using “List of Diagnostic Trouble Code (DTC)”. <Ref. to EN(H4SO)(diag)-71, List of Diagnostic Trouble Code (DTC).>	Go to step 2.
2	CHECK THROTTLE POSITION SENSOR CIRCUIT. Check throttle position sensor circuit. <Ref. to 4AT(diag)-46, DTC 31 THROTTLE POSITION SENSOR, Diagnostic Procedure with Diagnostic Trouble Code (DTC).>	Is there any trouble in throttle position sensor circuit?	Repair or replace the throttle position sensor circuit.	Go to step 3.
3	CHECK FRONT VEHICLE SPEED SENSOR CIRCUIT. Check front vehicle speed sensor circuit. <Ref. to 4AT(diag)-52, DTC 33 FRONT VEHICLE SPEED SENSOR, Diagnostic Procedure with Diagnostic Trouble Code (DTC).>	Is there any trouble in front vehicle speed sensor circuit?	Repair or replace the front vehicle speed sensor circuit.	Go to step 4.
4	CHECK TORQUE CONVERTER TURBINE SPEED SENSOR CIRCUIT. Check torque converter turbine speed sensor circuit. <Ref. to 4AT(diag)-57, DTC 36 TORQUE CONVERTER TURBINE SPEED SENSOR, Diagnostic Procedure with Diagnostic Trouble Code (DTC).>	Is there any trouble in torque converter turbine speed sensor circuit?	Repair or replace the torque converter turbine speed sensor circuit.	Go to step 5.
5	CHECK POOR CONTACT. Check poor contact in TCM connector.	Is there poor contact in TCM connector?	Repair poor contact in TCM connector.	Go to step 6.
6	CHECK MECHANICAL TROUBLE. Check mechanical trouble in automatic transmission.	Is there any mechanical trouble in automatic transmission?	Repair or replace the automatic transmission. <Ref. to 4AT-32, INSPECTION, Road Test.>	Replace the TCM. <Ref. to 4AT-67, Transmission Control Module (TCM).>

Diagnostic Procedure with Diagnostic Trouble Code (DTC)

ENGINE (DIAGNOSTICS)

CD:DTC P0741 TORQUE CONVERTER CLUTCH CIRCUIT PERFORMANCE OR STUCK OFF

DTC DETECTING CONDITION:

- Two consecutive driving cycles with fault
- GENERAL DESCRIPTION <Ref. to GD(H4SO)-178, DTC P0741 TORQUE CONVERTER CLUTCH CIRCUIT PERFORMANCE OR STUCK OFF, Diagnostic Trouble Code (DTC) Detecting Criteria.>

TROUBLE SYMPTOM:

- No lock-up (after engine warm-up)
- No shift or excessive tight corner “braking”

CAUTION:

After repair or replacement of faulty parts, conduct Clear Memory Mode <Ref. to EN(H4SO)(diag)-44, OPERATION, Clear Memory Mode.> and Inspection Mode <Ref. to EN(H4SO)(diag)-37, OPERATION, Inspection Mode.>.

Step	Check	Yes	No
1	CHECK ANY OTHER DTC ON DISPLAY.	Is any other DTC displayed?	Inspect the relevant DTC using “List of Diagnostic Trouble Code (DTC)”. <Ref. to EN(H4SO)(diag)-71, List of Diagnostic Trouble Code (DTC).>
2	CHECK LOCK-UP DUTY SOLENOID CIRCUIT. Check lock-up duty solenoid circuit. <Ref. to 4AT(diag)-87, DTC 77 LOCK-UP DUTY SOLENOID, Diagnostic Procedure with Diagnostic Trouble Code (DTC).>	Is there any trouble in lock-up duty solenoid circuit?	Repair or replace the lock-up duty solenoid circuit.
3	CHECK THROTTLE POSITION SENSOR CIRCUIT. Check throttle position sensor circuit. <Ref. to 4AT(diag)-46, DTC 31 THROTTLE POSITION SENSOR, Diagnostic Procedure with Diagnostic Trouble Code (DTC).>	Is there any trouble in throttle position sensor circuit?	Repair or replace the throttle position sensor circuit.
4	CHECK TORQUE CONVERTER TURBINE SPEED SENSOR CIRCUIT. Check torque converter turbine speed sensor circuit. <Ref. to 4AT(diag)-57, DTC 36 TORQUE CONVERTER TURBINE SPEED SENSOR, Diagnostic Procedure with Diagnostic Trouble Code (DTC).>	Is there any trouble in torque converter turbine speed sensor circuit?	Repair or replace the torque converter turbine speed sensor circuit.
5	CHECK ENGINE SPEED INPUT CIRCUIT. Check engine speed input circuit. <Ref. to 4AT(diag)-39, DTC 11 ENGINE SPEED SIGNAL, Diagnostic Procedure with Diagnostic Trouble Code (DTC).>	Is there any trouble in engine speed input circuit?	Repair or replace the engine speed input circuit.
6	CHECK INHIBITOR SWITCH CIRCUIT. Check inhibitor switch circuit. <Ref. to 4AT(diag)-104, CHECK INHIBITOR SWITCH, Diagnostic Procedure without Diagnostic Trouble Code (DTC).>	Is there any trouble in inhibitor switch circuit?	Repair or replace the inhibitor switch circuit.

Diagnostic Procedure with Diagnostic Trouble Code (DTC)

ENGINE (DIAGNOSTICS)

Step	Check	Yes	No
7 CHECK BRAKE LIGHT SWITCH CIRCUIT. Check brake light switch circuit. <Ref. to 4AT(diag)-103, CHECK BRAKE SWITCH, Diagnostic Procedure without Diagnostic Trouble Code (DTC).>	Is there any trouble in brake light switch circuit?	Repair or replace the brake light switch circuit.	Go to step 8 .
8 CHECK ATF TEMPERATURE SENSOR CIRCUIT. Check ATF temperature sensor circuit. <Ref. to 4AT(diag)-43, DTC 27 ATF TEMPERATURE SENSOR, Diagnostic Procedure with Diagnostic Trouble Code (DTC).>	Is there any trouble in ATF temperature sensor circuit?	Repair or replace the ATF temperature sensor circuit.	Go to step 9 .
9 CHECK POOR CONTACT. Check poor contact in TCM connector.	Is there poor contact in TCM connector?	Repair poor contact in TCM connector.	Go to step 10 .
10 CHECK MECHANICAL TROUBLE. Check mechanical trouble in automatic transmission.	Is there any mechanical trouble in automatic transmission?	Repair or replace the automatic transmission. <Ref. to 4AT-32, INSPECTION, Road Test.>	Replace the TCM. <Ref. to 4AT-67, Transmission Control Module (TCM).>

Diagnostic Procedure with Diagnostic Trouble Code (DTC)

ENGINE (DIAGNOSTICS)

CE:DTC P0743 TORQUE CONVERTER CLUTCH CIRCUIT ELECTRICAL

GENERAL DESCRIPTION <Ref. to GD(H4SO)-179, DTC P0743 TORQUE CONVERTER CLUTCH CIRCUIT ELECTRICAL, Diagnostic Trouble Code (DTC) Detecting Criteria.>

NOTE:

Refer to AT-section for diagnostic procedure. <Ref. to 4AT(diag)-87, DTC 77 LOCK-UP DUTY SOLENOID, Diagnostic Procedure with Diagnostic Trouble Code (DTC).>

CF:DTC P0748 PRESSURE CONTROL SOLENOID “A” ELECTRICAL

GENERAL DESCRIPTION <Ref. to GD(H4SO)-180, DTC P0748 PRESSURE CONTROL SOLENOID “A” ELECTRICAL, Diagnostic Trouble Code (DTC) Detecting Criteria.>

NOTE:

Refer to AT-section for diagnostic procedure. <Ref. to 4AT(diag)-78, DTC 75 LINE PRESSURE DUTY SOLENOID, Diagnostic Procedure with Diagnostic Trouble Code (DTC).>

CG:DTC P0753 SHIFT SOLENOID “A” ELECTRICAL

GENERAL DESCRIPTION <Ref. to GD(H4SO)-181, DTC P0753 SHIFT SOLENOID “A” ELECTRICAL, Diagnostic Trouble Code (DTC) Detecting Criteria.>

NOTE:

Refer to AT-section for diagnostic procedure. <Ref. to 4AT(diag)-65, DTC 71 SHIFT SOLENOID 1, Diagnostic Procedure with Diagnostic Trouble Code (DTC).>

CH:DTC P0758 SHIFT SOLENOID “B” ELECTRICAL

GENERAL DESCRIPTION <Ref. to GD(H4SO)-182, DTC P0758 SHIFT SOLENOID “B” ELECTRICAL, Diagnostic Trouble Code (DTC) Detecting Criteria.>

NOTE:

Refer to AT-section for diagnostic procedure. <Ref. to 4AT(diag)-68, DTC 72 SHIFT SOLENOID 2, Diagnostic Procedure with Diagnostic Trouble Code (DTC).>

CI: DTC P0771 SHIFT SOLENOID “E” PERFORMANCE OR STUCK OFF

GENERAL DESCRIPTION <Ref. to GD(H4SO)-183, DTC P0771 SHIFT SOLENOID “E” PERFORMANCE OR STUCK OFF, Diagnostic Trouble Code (DTC) Detecting Criteria.>

NOTE:

Refer to AT-section for diagnostic procedure. <Ref. to 4AT(diag)-71, DTC 73 LOW CLUTCH TIMING SOLENOID, Diagnostic Procedure with Diagnostic Trouble Code (DTC).>

CJ:DTC P0778 PRESSURE CONTROL SOLENOID “B” ELECTRICAL

GENERAL DESCRIPTION <Ref. to GD(H4SO)-184, DTC P0778 PRESSURE CONTROL SOLENOID “B” ELECTRICAL, Diagnostic Trouble Code (DTC) Detecting Criteria.>

NOTE:

Refer to AT-section for diagnostic procedure. <Ref. to 4AT(diag)-83, DTC 76 2-4 BRAKE DUTY SOLENOID, Diagnostic Procedure with Diagnostic Trouble Code (DTC).>

CK:DTC P0785 SHIFT/TIMING SOLENOID

GENERAL DESCRIPTION <Ref. to GD(H4SO)-185, DTC P0785 SHIFT/TIMING SOLENOID, Diagnostic Trouble Code (DTC) Detecting Criteria.>

NOTE:

Refer to AT-section for diagnostic procedure. <Ref. to 4AT(diag)-74, DTC 74 2-4 BRAKE TIMING SOLENOID, Diagnostic Procedure with Diagnostic Trouble Code (DTC).>

Diagnostic Procedure with Diagnostic Trouble Code (DTC)

ENGINE (DIAGNOSTICS)

CL:DTC P0851 NEUTRAL SWITCH INPUT CIRCUIT LOW

DTC DETECTING CONDITION:

- Two consecutive driving cycles with fault
- GENERAL DESCRIPTION <Ref. to GD(H4SO)-186, DTC P0851 NEUTRAL SWITCH INPUT CIRCUIT LOW, Diagnostic Trouble Code (DTC) Detecting Criteria.>

TROUBLE SYMPTOM:

Erroneous idling

CAUTION:

After repair or replacement of faulty parts, conduct Clear Memory Mode <Ref. to EN(H4SO)(diag)-44, OPERATION, Clear Memory Mode.> and Inspection Mode <Ref. to EN(H4SO)(diag)-37, OPERATION, Inspection Mode.>.

WIRING DIAGRAM:

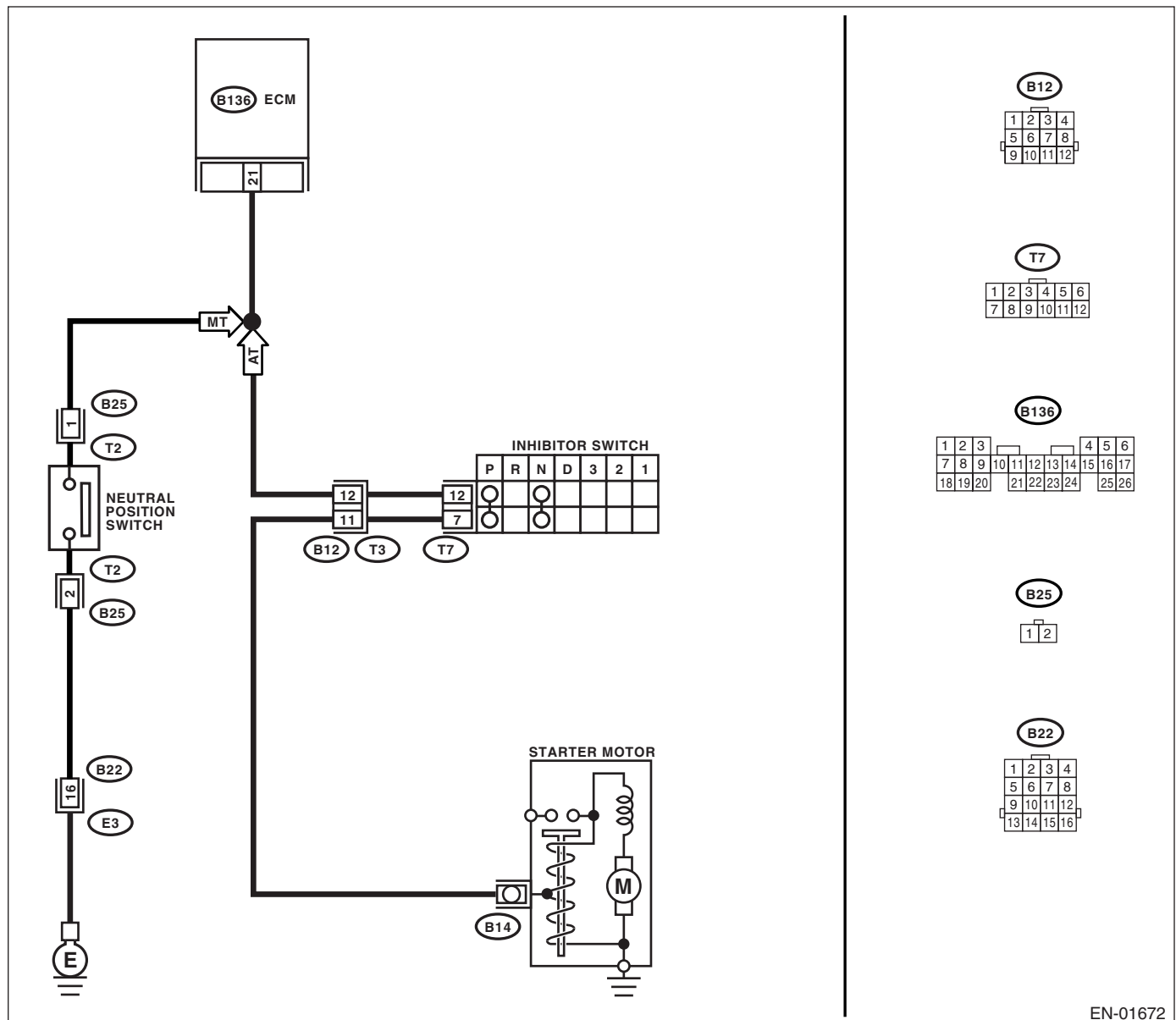

EN-01672

Diagnostic Procedure with Diagnostic Trouble Code (DTC)

ENGINE (DIAGNOSTICS)

Step	Check	Yes	No
1 CHECK OTHER DTC ON DISPLAY.	Is any other DTC displayed?	Inspect DTC P0705 using "List of Diagnostic Trouble Code (DTC)". <Ref. to EN(H4SO)(diag)-71, List of Diagnostic Trouble Code (DTC).>	Go to step 2.
2 CHECK INPUT SIGNAL FOR ECM. 1) Turn the ignition switch to ON. 2) Place the select lever except for "N" and "P" ranges. 3) Measure the voltage between ECM and chassis ground. Connector & terminal (B136) No. 21 (+) — Chassis ground (-):	Is the voltage 4.5 — 5.5 V?	Even if malfunction indicator light lights up, the circuit has returned to a normal condition at this time.	Go to step 3.
3 CHECK HARNESS BETWEEN ECM AND TRANSMISSION HARNESS CONNECTOR. 1) Turn the ignition switch to OFF. 2) Disconnect the connectors from ECM and transmission harness connector (T3). 3) Measure the resistance of harness between ECM connector and chassis ground. Connector & terminal (B136) No. 21 — Chassis ground:	Is the resistance more than 1 MΩ?	Go to step 4.	Repair ground short circuit in harness between ECM and transmission harness connector.
4 CHECK TRANSMISSION HARNESS CONNECTOR. 1) Disconnect the connector from inhibitor switch. 2) Measure the resistance of harness between transmission harness connector and engine ground. Connector & terminal (T3) No. 12 — Engine ground:	Is the resistance more than 1 MΩ?	Go to step 5.	Repair ground short circuit in harness between transmission harness and inhibitor switch connector.
5 CHECK INHIBITOR SWITCH. Measure the resistance between inhibitor switch connector the receptacle's terminals in select lever except for "N" and "P" range. Terminals No. 7 — No. 12:	Is the resistance more than 1 MΩ?	Go to step 6.	Replace the inhibitor switch. <Ref. to 4AT-46, Inhibitor Switch.>
6 CHECK SELECTOR CABLE CONNECTION.	Is there any fault in selector cable connection to inhibitor switch?	Repair selector cable connection. <Ref. to CS-26, INSPECTION, Select Cable.>	Contact SOA Service Center. NOTE: Inspection by DTM is required, because probable cause is deterioration of multiple parts.

Diagnostic Procedure with Diagnostic Trouble Code (DTC)

ENGINE (DIAGNOSTICS)

CM:DTC P0851 NEUTRAL SWITCH INPUT CIRCUIT LOW (MT MODEL)

DTC DETECTING CONDITION:

- Two consecutive driving cycles with fault
- GENERAL DESCRIPTION <Ref. to GD(H4SO)-186, DTC P0851 NEUTRAL SWITCH INPUT CIRCUIT LOW, Diagnostic Trouble Code (DTC) Detecting Criteria.>

TROUBLE SYMPTOM:

Erroneous idling

CAUTION:

After repair or replacement of faulty parts, conduct Clear Memory Mode <Ref. to EN(H4SO)(diag)-44, OPERATION, Clear Memory Mode.> and Inspection Mode <Ref. to EN(H4SO)(diag)-37, OPERATION, Inspection Mode.>.

WIRING DIAGRAM:

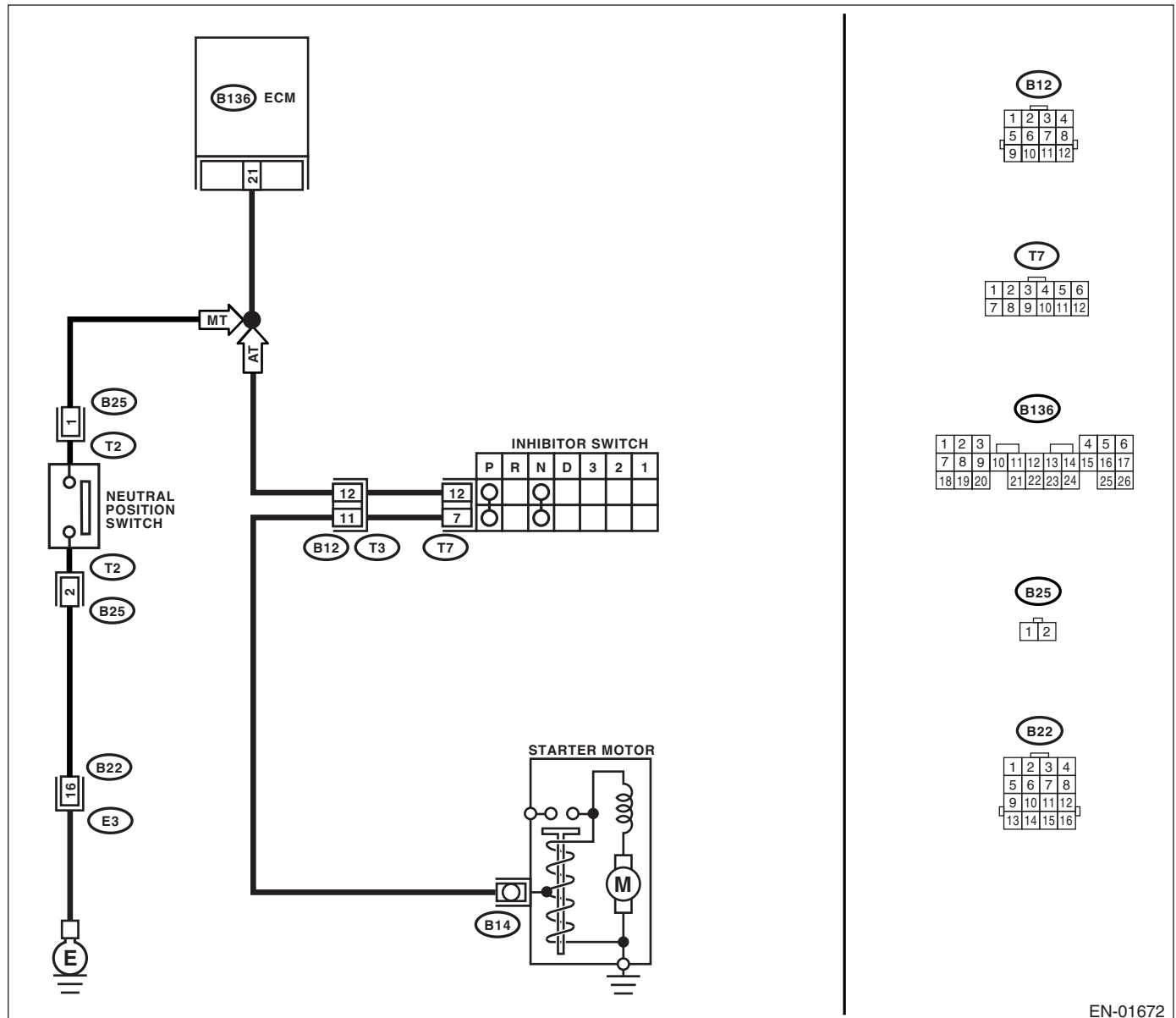

EN-01672

Diagnostic Procedure with Diagnostic Trouble Code (DTC)

ENGINE (DIAGNOSTICS)

Step	Check	Yes	No
1 CHECK INPUT SIGNAL FOR ECM. 1) Turn the ignition switch to ON. 2) Place the shift lever in neutral. 3) Measure the voltage between ECM and chassis ground. Connector & terminal (B136) No. 21 (+) — Chassis ground (-):	Is the voltage more than 10 V?	Go to step 2.	Go to step 4.
2 CHECK INPUT SIGNAL FOR ECM. 1) Place the shift lever in a position except for neutral. 2) Measure the voltage between ECM and chassis ground. Connector & terminal (B136) No. 21 (+) — Chassis ground (-):	Is the voltage less than 1 V?	Go to step 3.	Go to step 4.
3 CHECK POOR CONTACT. Check poor contact in ECM connector.	Is there poor contact in ECM connector?	Repair poor contact in ECM connector.	Contact SOA Service Center.
4 CHECK NEUTRAL POSITION SWITCH. 1) Turn the ignition switch to OFF. 2) Disconnect the connector from transmission harness. 3) Place the shift lever in neutral. 4) Measure the resistance between transmission harness and connector terminals. Connector & terminal (T2) No. 1 — No. 2:	Is the resistance more than 1 M Ω ?	Go to step 5.	Repair short circuit in transmission harness or replace neutral position switch.
5 CHECK NEUTRAL POSITION SWITCH. 1) Place the shift lever in a position except for neutral. 2) Measure the resistance between transmission harness connector terminals. Connector & terminal (T2) No. 1 — No. 2:	Is the resistance less than 1 Ω ?	Go to step 6.	Repair short circuit in transmission harness or replace neutral position switch.
6 CHECK HARNESS BETWEEN ECM AND NEUTRAL POSITION SWITCH CONNECTOR. Measure the resistance between ECM and chassis ground. Connector & terminal (B136) No. 21 — Chassis ground:	Is the resistance more than 1 M Ω ?	Go to step 7.	Repair ground short circuit in harness between ECM and transmission harness connector.
7 CHECK HARNESS BETWEEN ECM AND NEUTRAL POSITION SWITCH CONNECTOR. 1) Disconnect the connector from ECM. 2) Measure the resistance of harness between ECM and transmission harness connector. Connector & terminal (B136) No. 21 — (B25) No. 1:	Is the resistance less than 1 Ω ?	Go to step 8.	Repair open circuit in harness between ECM and transmission harness connector.
8 CHECK HARNESS BETWEEN ECM AND NEUTRAL POSITION SWITCH CONNECTOR. Measure the resistance of harness between transmission harness connector and engine ground. Connector & terminal (B25) No. 2 — Engine ground:	Is the resistance less than 5 Ω ?	Go to step 9.	Repair open circuit between transmission harness connector and engine ground terminal.

Diagnostic Procedure with Diagnostic Trouble Code (DTC)

ENGINE (DIAGNOSTICS)

Step	Check	Yes	No
9	CHECK POOR CONTACT. Check poor contact in transmission harness connector.	Is there poor contact in transmission harness connector?	Repair poor contact in transmission harness connector.

CN:DTC P0852 NEUTRAL SWITCH INPUT CIRCUIT HIGH (AT MODEL)

DTC DETECTING CONDITION:

- Two consecutive driving cycles with fault
- GENERAL DESCRIPTION <Ref. to GD(H4SO)-188, DTC P0852 NEUTRAL SWITCH INPUT CIRCUIT HIGH, Diagnostic Trouble Code (DTC) Detecting Criteria.>

TROUBLE SYMPTOM:

Erroneous idling

CAUTION:

After repair or replacement of faulty parts, conduct Clear Memory Mode <Ref. to EN(H4SO)(diag)-44, OPERATION, Clear Memory Mode.> and Inspection Mode <Ref. to EN(H4SO)(diag)-37, OPERATION, Inspection Mode.>.

WIRING DIAGRAM:

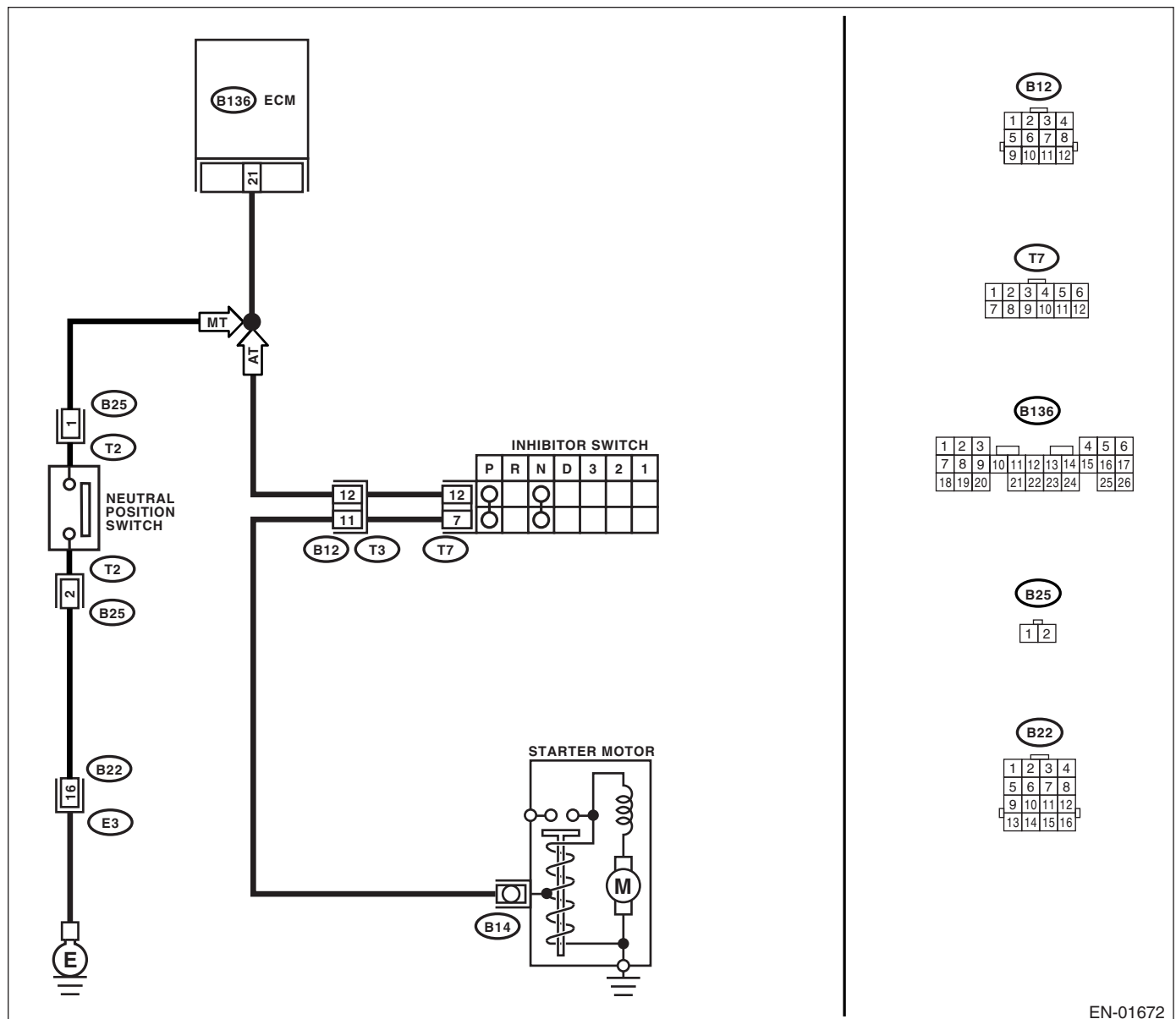

EN-01672

Diagnostic Procedure with Diagnostic Trouble Code (DTC)

ENGINE (DIAGNOSTICS)

Step	Check	Yes	No
1 CHECK OTHER DTC ON DISPLAY.	Is any other DTC displayed?	Inspect DTC using "List of Diagnostic Trouble Code (DTC)". <Ref. to EN(H4SO)(diag)-71, List of Diagnostic Trouble Code (DTC).>	Go to step 2.
2 CHECK INPUT SIGNAL FOR ECM. 1) Turn the ignition switch to ON. 2) Measure the voltage between ECM and chassis ground in select lever "N" and "P" ranges. <i>Connector & terminal</i> <i>(B136) No. 21 (+) — Chassis ground (-):</i>	Is the voltage less than 1 V?	Go to step 3.	Go to step 5.
3 CHECK INPUT SIGNAL FOR ECM. Measure the voltage between ECM and chassis ground in select lever except for "N" and "P" ranges. <i>Connector & terminal</i> <i>(B136) No. 21 (+) — Chassis ground (-):</i>	Is the voltage 4.5 — 5.5 V?	Go to step 4.	Go to step 5.
4 CHECK POOR CONTACT. Check poor contact in ECM connector.	Is there poor contact in ECM connector?	Repair poor contact in ECM connector.	Contact SOA Service Center. NOTE: Inspection by DTM is required, because probable cause is deterioration of multiple parts.
5 CHECK INPUT SIGNAL FOR ECM. Measure the voltage between ECM and chassis ground. <i>Connector & terminal</i> <i>(B136) No. 21 (+) — Chassis ground (-):</i>	Is the voltage more than 10 V?	Repair battery short circuit in harness between ECM and inhibitor switch connector.	Go to step 6.
6 CHECK HARNESS BETWEEN ECM AND INHIBITOR SWITCH CONNECTOR. 1) Turn the ignition switch to OFF. 2) Disconnect the connectors from ECM and inhibitor switch. 3) Measure the resistance of harness between ECM and inhibitor switch connector. <i>Connector & terminal</i> <i>(B136) No. 21 — (T7) No. 12:</i>	Is the resistance less than 1 Ω ?	Go to step 7.	Repair harness and connector. NOTE: In this case, repair the following: <ul style="list-style-type: none"> • Open circuit in harness between ECM and inhibitor switch connector • Poor contact in coupling connector • Poor contact in inhibitor switch connector • Poor contact in ECM connector

Diagnostic Procedure with Diagnostic Trouble Code (DTC)

ENGINE (DIAGNOSTICS)

Step	Check	Yes	No
<p>7 CHECK INHIBITOR SWITCH GROUND LINE. Measure the resistance of harness between inhibitor switch connector and engine ground. <i>Connector & terminal</i> <i>(T7) No. 12 — Engine ground:</i></p>	<p>Is the resistance less than 5 Ω?</p>	<p>Go to step 8.</p>	<p>Repair open circuit in harness between inhibitor switch connector and starter motor ground line.</p> <p>NOTE: In this case, repair the following:</p> <ul style="list-style-type: none"> • Open circuit in harness between inhibitor switch connector and starter motor ground line • Poor contact in starter motor connector • Poor contact in starter motor ground • Starter motor
<p>8 CHECK INHIBITOR SWITCH. Measure the resistance between inhibitor switch connector receptacle's terminals in select lever "N" and "P" ranges. <i>Terminals</i> <i>No. 7 — No. 12:</i></p>	<p>Is the resistance less than 1 Ω?</p>	<p>Go to step 9.</p>	<p>Replace the inhibitor switch. <Ref. to 4AT-46, Inhibitor Switch.></p>
<p>9 CHECK SELECTOR CABLE CONNECTION.</p>	<p>Is there any fault in selector cable connection to inhibitor switch?</p>	<p>Repair selector cable connection. <Ref. to CS-26, INSPECTION, Select Cable.></p>	<p>Contact SOA Service Center.</p> <p>NOTE: Inspection by DTM is required, because probable cause is deterioration of multiple parts.</p>

Diagnostic Procedure with Diagnostic Trouble Code (DTC)

ENGINE (DIAGNOSTICS)

CO:DTC P0852 NEUTRAL SWITCH INPUT CIRCUIT HIGH (MT MODEL)

DTC DETECTING CONDITION:

- Two consecutive driving cycles with fault
- GENERAL DESCRIPTION <Ref. to GD(H4SO)-188, DTC P0852 NEUTRAL SWITCH INPUT CIRCUIT HIGH, Diagnostic Trouble Code (DTC) Detecting Criteria.>

TROUBLE SYMPTOM:

Erroneous idling

CAUTION:

After repair or replacement of faulty parts, conduct CLEAR MEMORY MODE <Ref. to EN(H4SO)(diag)-44, OPERATION, Clear Memory Mode.> and INSPECTION MODE <Ref. to EN(H4SO)(diag)-37, OPERATION, Inspection Mode.>.

WIRING DIAGRAM:

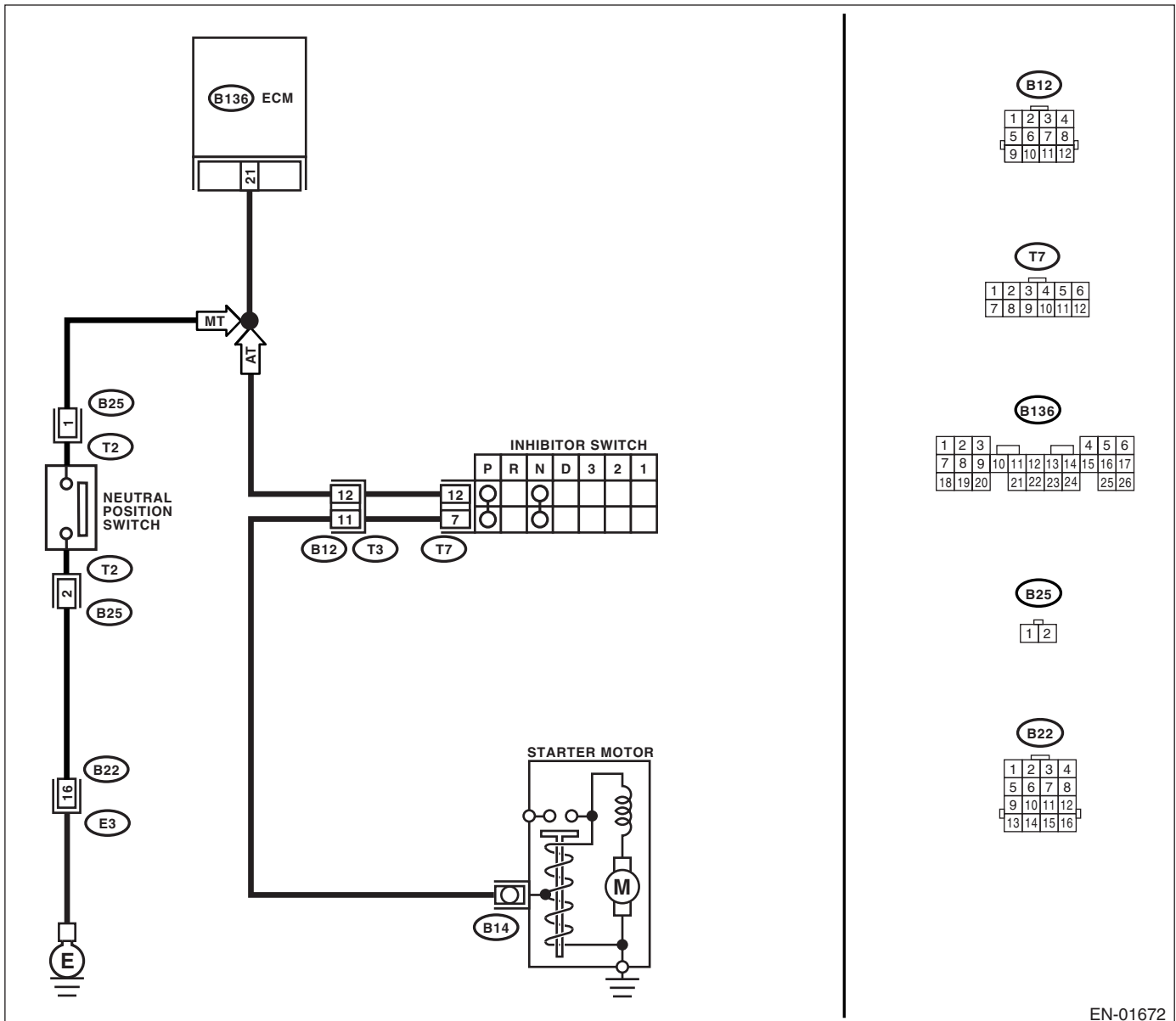

EN-01672

Diagnostic Procedure with Diagnostic Trouble Code (DTC)

ENGINE (DIAGNOSTICS)

Step	Check	Yes	No
1 CHECK INPUT SIGNAL FOR ECM. 1) Turn ignition switch to ON. 2) Place the shift lever in neutral. 3) Measure the voltage between ECM and chassis ground. Connector & terminal (B136) No. 21 (+) — Chassis ground (-):	Is the voltage more than 5 V?	Go to step 2.	Go to step 4.
2 CHECK INPUT SIGNAL FOR ECM. 1) Place the shift lever in a position except for neutral. 2) Measure the voltage between ECM and chassis ground. Connector & terminal (B136) No. 21 (+) — Chassis ground (-):	Is the voltage less than 1 V?	Go to step 3.	Go to step 5.
3 CHECK FOR POOR CONTACT. Check for poor contact in ECM connector.	Is there poor contact in ECM connector?	Repair poor contact in ECM connector.	Contact SOA Service Center. NOTE: Inspection by DTM is required, because probable cause is deterioration of multiple parts.
4 CHECK NEUTRAL SWITCH. 1) Place the shift lever in a position except for neutral. 2) Measure the resistance between transmission harness connector terminals. Connector & terminal (T2) No. 1 — No. 2:	Is the resistance less than 1 Ω ?	Go to step 5.	Repair open circuit in transmission harness or replace neutral switch.
5 CHECK HARNESS BETWEEN ECM AND NEUTRAL SWITCH CONNECTOR. 1) Disconnect the connector from ECM. 2) Measure the resistance of harness between ECM and transmission harness connector. Connector & terminal (B136) No. 21 — (B25) No. 1:	Is the resistance less than 1 Ω ?	Go to step 6.	Repair open circuit in harness between ECM and transmission harness connector.
6 CHECK HARNESS BETWEEN ECM AND NEUTRAL SWITCH CONNECTOR. Measure the resistance of harness between transmission harness connector and engine ground. Connector & terminal (B25) No. 2 — Engine ground:	Is the resistance less than 5 Ω ?	Go to step 7.	Repair harness and connector. NOTE: In this case, repair the following: • Open circuit in harness between transmission harness connector and engine ground. • Poor contact in coupling connector

Diagnostic Procedure with Diagnostic Trouble Code (DTC)

ENGINE (DIAGNOSTICS)

	Step	Check	Yes	No
7	CHECK FOR POOR CONTACT. Check for poor contact in transmission harness connector.	Is there a poor contact in the transmission harness connector?	Repair poor contact in transmission harness connector.	Contact SOA Service Center. NOTE: Inspection by DTM is required, because probable cause is deterioration of multiple parts.

Diagnostic Procedure with Diagnostic Trouble Code (DTC)

ENGINE (DIAGNOSTICS)

CP:DTC P0864 TCM COMMUNICATION CIRCUIT RANGE/PERFORMANCE

DTC DETECTING CONDITION:

- Two consecutive driving cycles with fault
- GENERAL DESCRIPTION <Ref. to GD(H4SO)-190, DTC P0864 TCM COMMUNICATION CIRCUIT RANGE/PERFORMANCE, Diagnostic Trouble Code (DTC) Detecting Criteria.>

CAUTION:

After repair or replacement of faulty parts, conduct Clear Memory Mode <Ref. to EN(H4SO)(diag)-44, OPERATION, Clear Memory Mode.> and Inspection Mode <Ref. to EN(H4SO)(diag)-37, OPERATION, Inspection Mode.>.

WIRING DIAGRAM:

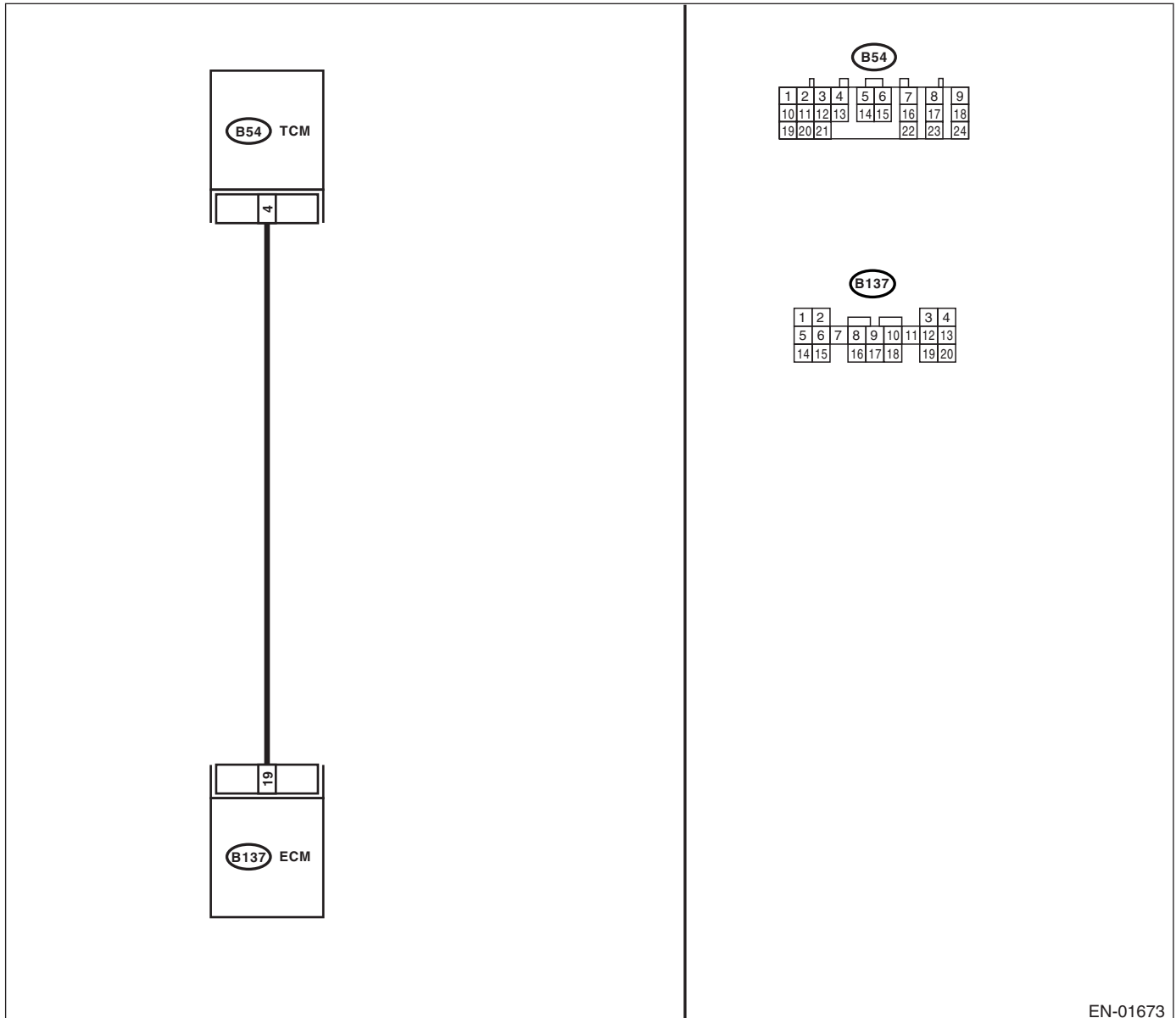

EN-01673

Diagnostic Procedure with Diagnostic Trouble Code (DTC)

ENGINE (DIAGNOSTICS)

Step	Check	Yes	No
1 CHECK DRIVING CONDITION. 1) Start and warm-up the engine until the radiator fan makes one complete rotation. 2) Drive the vehicle.	Is the AT shift control functioning properly?	Go to step 2.	Replace the TCM. <Ref. to 4AT-67, Transmission Control Module (TCM).>
2 CHECK ACCESSORY.	Are car phone and/or CB installed on vehicle?	Repair grounding line of car phone or CB system.	Replace the TCM. <Ref. to 4AT-67, Transmission Control Module (TCM).>

Diagnostic Procedure with Diagnostic Trouble Code (DTC)

ENGINE (DIAGNOSTICS)

CQ:DTC P0865 TCM COMMUNICATION CIRCUIT LOW

DTC DETECTING CONDITION:

- Two consecutive driving cycles with fault
- GENERAL DESCRIPTION <Ref. to GD(H4SO)-191, DTC P0865 TCM COMMUNICATION CIRCUIT LOW, Diagnostic Trouble Code (DTC) Detecting Criteria.>

CAUTION:

After repair or replacement of faulty parts, conduct Clear Memory Mode <Ref. to EN(H4SO)(diag)-44, OPERATION, Clear Memory Mode.> and Inspection Mode <Ref. to EN(H4SO)(diag)-37, OPERATION, Inspection Mode.>.

WIRING DIAGRAM:

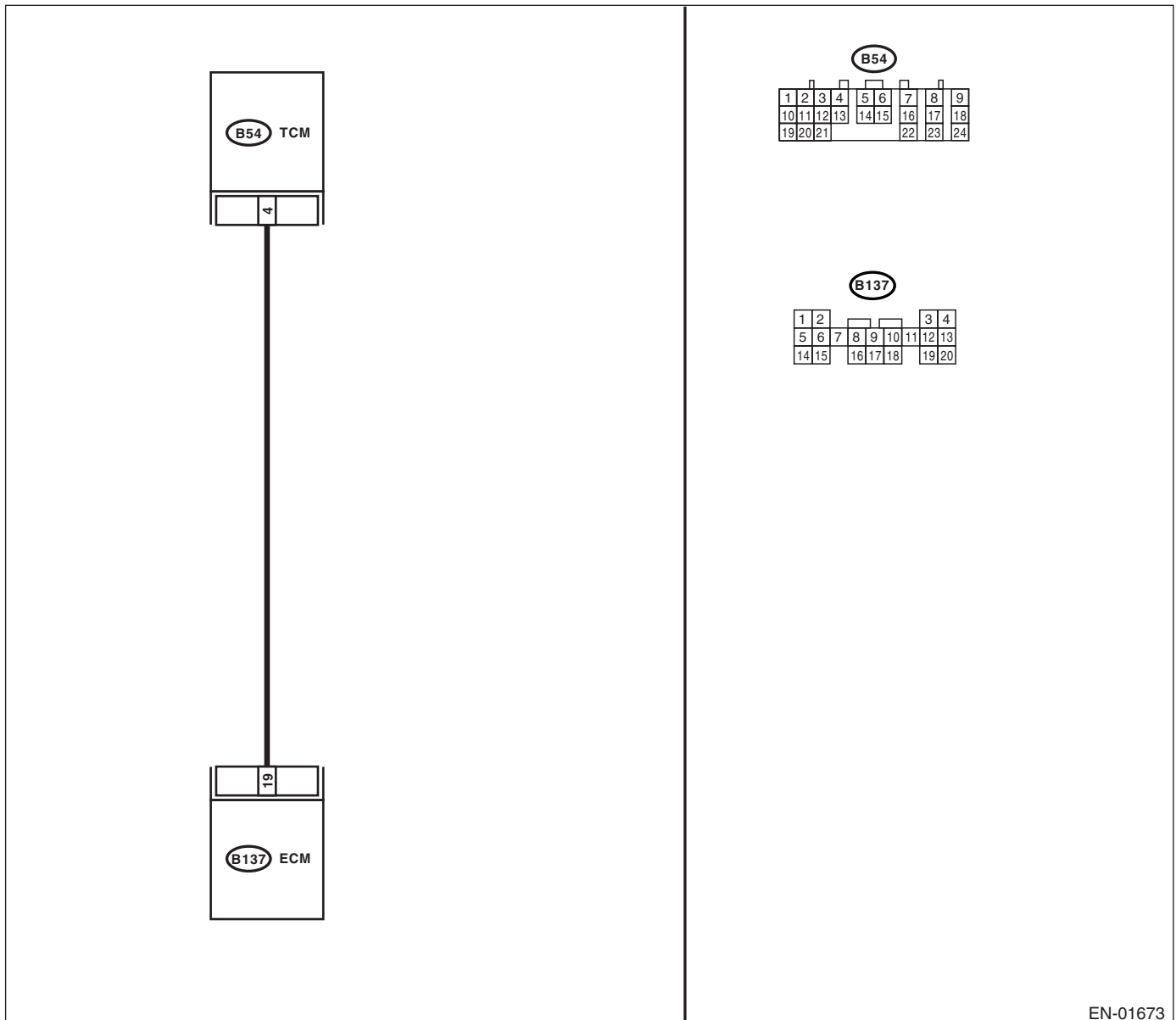

EN-01673

Diagnostic Procedure with Diagnostic Trouble Code (DTC)

ENGINE (DIAGNOSTICS)

Step	Check	Yes	No
1 CHECK HARNESS BETWEEN ECM AND TCM CONNECTOR. 1) Turn the ignition switch to ON. 2) Measure the voltage between ECM and chassis ground. <i>Connector & terminal</i> <i>(B137) No. 19 (+) — Chassis ground (-):</i>	Is the voltage less than 1 V?	Go to step 2.	Even if malfunction indicator light lights up, the circuit has returned to a normal condition at this time. NOTE: In this case, repair the following: <ul style="list-style-type: none"> • Poor contact in ECM connector • Poor contact in TCM connector
2 CHECK HARNESS BETWEEN ECM AND TCM CONNECTOR. 1) Turn the ignition switch to OFF. 2) Disconnect the connector from ECM and TCM. 3) Measure the resistance of harness between ECM and chassis ground. <i>Connector & terminal</i> <i>(B137) No. 19 — Chassis ground:</i>	Is the resistance more than 1 MΩ?	Go to step 3.	Repair ground short circuit in harness between ECM and TCM connector.
3 CHECK OUTPUT SIGNAL FOR ECM. 1) Connect the connector to ECM. 2) Turn the ignition switch to ON. 3) Measure the voltage between ECM and chassis ground. <i>Connector & terminal</i> <i>(B137) No. 19 (+) — Chassis ground (-):</i>	Is the voltage more than 5 V?	Go to step 4.	Repair poor contact in ECM connector.
4 CHECK DTC FOR AUTOMATIC TRANSMISSION. Read the DTC for automatic transmission. <Ref. to 4AT(diag)-24, Read Diagnostic Trouble Code (DTC).>	Does the DTC appear for automatic transmission?	Check DTC for automatic transmission. <Ref. to 4AT(diag)-39, Diagnostic Procedure with Diagnostic Trouble Code (DTC).>	Replace the TCM. <Ref. to 4AT-67, Transmission Control Module (TCM).>

Diagnostic Procedure with Diagnostic Trouble Code (DTC)

ENGINE (DIAGNOSTICS)

CR:DTC P0866 TCM COMMUNICATION CIRCUIT HIGH

DTC DETECTING CONDITION:

- Two consecutive driving cycles with fault
- GENERAL DESCRIPTION <Ref. to GD(H4SO)-192, DTC P0866 TCM COMMUNICATION CIRCUIT HIGH, Diagnostic Trouble Code (DTC) Detecting Criteria.>

CAUTION:

After repair or replacement of faulty parts, conduct Clear Memory Mode <Ref. to EN(H4SO)(diag)-44, OPERATION, Clear Memory Mode.> and Inspection Mode <Ref. to EN(H4SO)(diag)-37, OPERATION, Inspection Mode.>.

WIRING DIAGRAM:

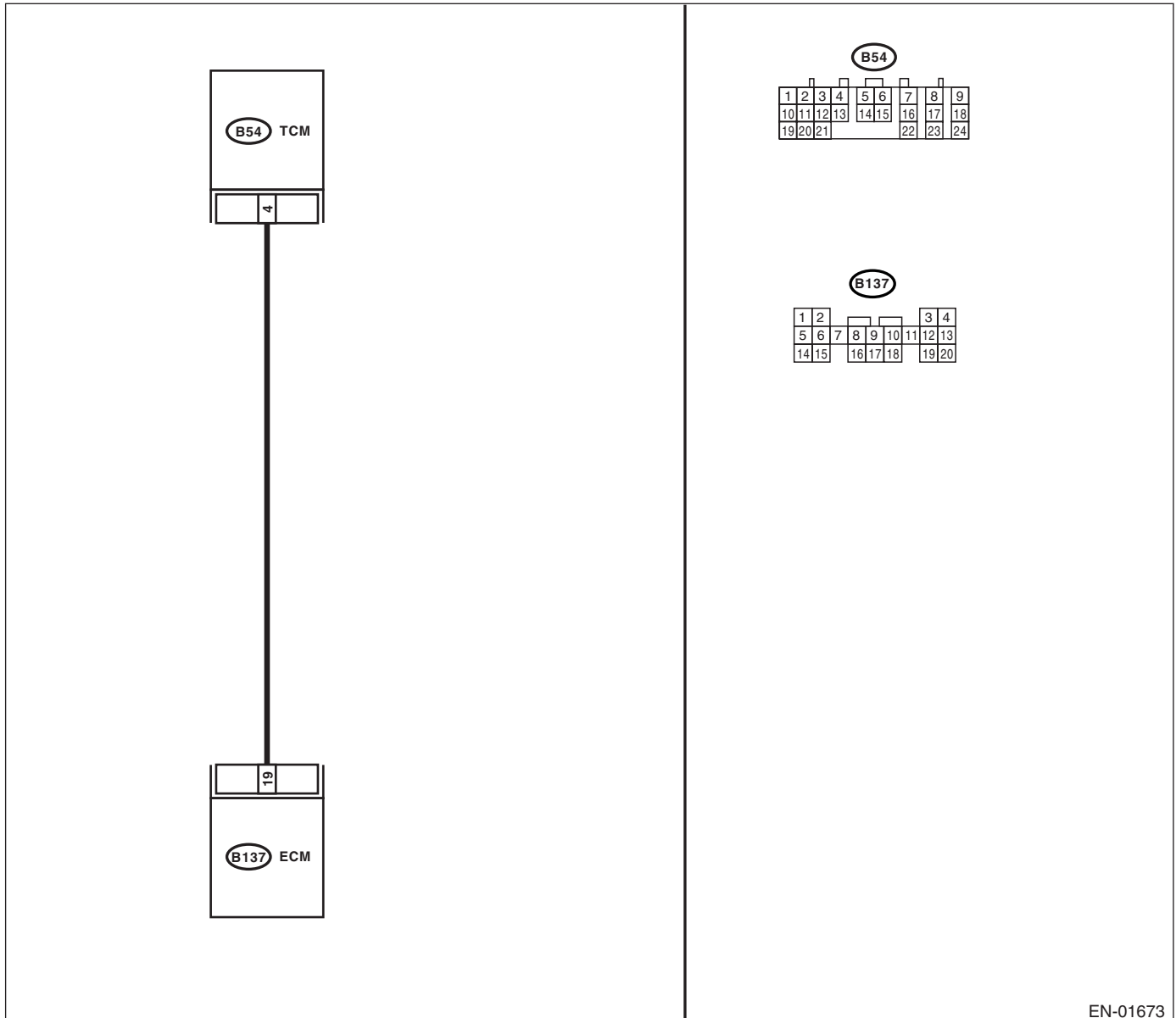

EN-01673

Diagnostic Procedure with Diagnostic Trouble Code (DTC)

ENGINE (DIAGNOSTICS)

Step	Check	Yes	No
1 CHECK HARNESS BETWEEN ECM AND TCM CONNECTOR. 1) Turn the ignition switch to ON. 2) Measure the voltage between ECM and chassis ground. <i>Connector & terminal</i> <i>(B137) No. 19 (+) — Chassis ground (-):</i>	Is the voltage more than 10 V?	Repair battery short circuit in harness between ECM and TCM connector.	Go to step 2.
2 CHECK HARNESS BETWEEN ECM AND TCM CONNECTOR. Measure the voltage between ECM connector and chassis ground. <i>Connector & terminal</i> <i>(B137) No. 19 (+) — Chassis ground (-):</i>	Is the voltage more than 4 V?	Go to step 5.	Go to step 3.
3 CHECK HARNESS BETWEEN ECM AND TCM CONNECTOR. Measure the voltage between ECM connector and chassis ground. <i>Connector & terminal</i> <i>(B137) No. 19 (+) — Chassis ground (-):</i>	Is the voltage less than 1 V?	Repair poor contact in ECM connector.	Go to step 4.
4 CHECK OUTPUT SIGNAL FROM ECM. Measure the voltage between ECM and chassis ground. <i>Connector & terminal</i> <i>(B137) No. 19 (+) — Chassis ground (-):</i>	Is the voltage 1 — 4 V?	Even if malfunction indicator light lights up, the circuit has returned to a normal condition at this time. NOTE: In this case, repair the following: • Poor contact in ECM connector • Poor contact in TCM connector	Contact SOA Service Center. NOTE: Inspection by DTM is required, because probable cause is deterioration of multiple parts.
5 CHECK HARNESS BETWEEN ECM AND TCM CONNECTOR. Measure the voltage between TCM and chassis ground. <i>Connector & terminal</i> <i>(B54) No. 4 (+) — Chassis ground (-):</i>	Is the voltage more than 4 V?	Go to step 6.	Repair open circuit in harness between ECM and TCM connector.
6 CHECK POOR CONTACT. Check poor contact in TCM connector.	Is there poor contact in TCM connector?	Repair poor contact in TCM connector.	Check TCM power supply line and grounding line.

Diagnostic Procedure with Diagnostic Trouble Code (DTC)

ENGINE (DIAGNOSTICS)

CS:DTC P1110 ATMOSPHERIC PRESSURE SENSOR CIRCUIT MALFUNCTION (LOW INPUT)

DTC DETECTING CONDITION:

- Immediately at fault recognition
- GENERAL DESCRIPTION <Ref. to GD(H4SO)-193, DTC P1110 ATMOSPHERIC PRESSURE SENSOR CIRCUIT MALFUNCTION (LOW INPUT), Diagnostic Trouble Code (DTC) Detecting Criteria.>

CAUTION:

After repair or replacement of faulty parts, conduct Clear Memory Mode <Ref. to EN(H4SO)(diag)-44, OPERATION, Clear Memory Mode.> and Inspection Mode <Ref. to EN(H4SO)(diag)-37, OPERATION, Inspection Mode.>.

Step	Check	Yes	No
1 CHECK ANY OTHER DTC ON DISPLAY.	Is any other DTC displayed?	Check DTC using the List of Diagnostic Trouble Code (DTC). <Ref. to EN(H4SO)(diag)-71, List of Diagnostic Trouble Code (DTC).> NOTE: It is not necessary to inspect DTC P1110.	Replace the ECM. <Ref. to FU(H4SO)-44, Engine Control Module (ECM).>

CT:DTC P1111 ATMOSPHERIC PRESSURE SENSOR CIRCUIT MALFUNCTION (HIGH INPUT)

DTC DETECTING CONDITION:

- Immediately at fault recognition
- GENERAL DESCRIPTION <Ref. to GD(H4SO)-194, DTC P1111 ATMOSPHERIC PRESSURE SENSOR CIRCUIT MALFUNCTION (HIGH INPUT), Diagnostic Trouble Code (DTC) Detecting Criteria.>

CAUTION:

After repair or replacement of faulty parts, conduct Clear Memory Mode <Ref. to EN(H4SO)(diag)-44, OPERATION, Clear Memory Mode.> and Inspection Mode <Ref. to EN(H4SO)(diag)-37, OPERATION, Inspection Mode.>.

Step	Check	Yes	No
1 CHECK ANY OTHER DTC ON DISPLAY.	Is any other DTC displayed?	Check DTC using the List of Diagnostic Trouble Code (DTC). <Ref. to EN(H4SO)(diag)-71, List of Diagnostic Trouble Code (DTC).> NOTE: It is not necessary to inspect DTC P1111.	Replace the ECM. <Ref. to FU(H4SO)-44, Engine Control Module (ECM).>

Diagnostic Procedure with Diagnostic Trouble Code (DTC)

ENGINE (DIAGNOSTICS)

CU:DTC P1134 A/F SENSOR MICRO-COMPUTER PROBLEM

DTC DETECTING CONDITION:

- Immediately at fault recognition
- GENERAL DESCRIPTION <Ref. to GD(H4SO)-195, DTC P1134 A/F SENSOR MICRO-COMPUTER PROBLEM, Diagnostic Trouble Code (DTC) Detecting Criteria.>

CAUTION:

After repair or replacement of faulty parts, conduct Clear Memory Mode <Ref. to EN(H4SO)(diag)-44, OPERATION, Clear Memory Mode.> and Inspection Mode <Ref. to EN(H4SO)(diag)-37, Inspection Mode.>.

WIRING DIAGRAM:

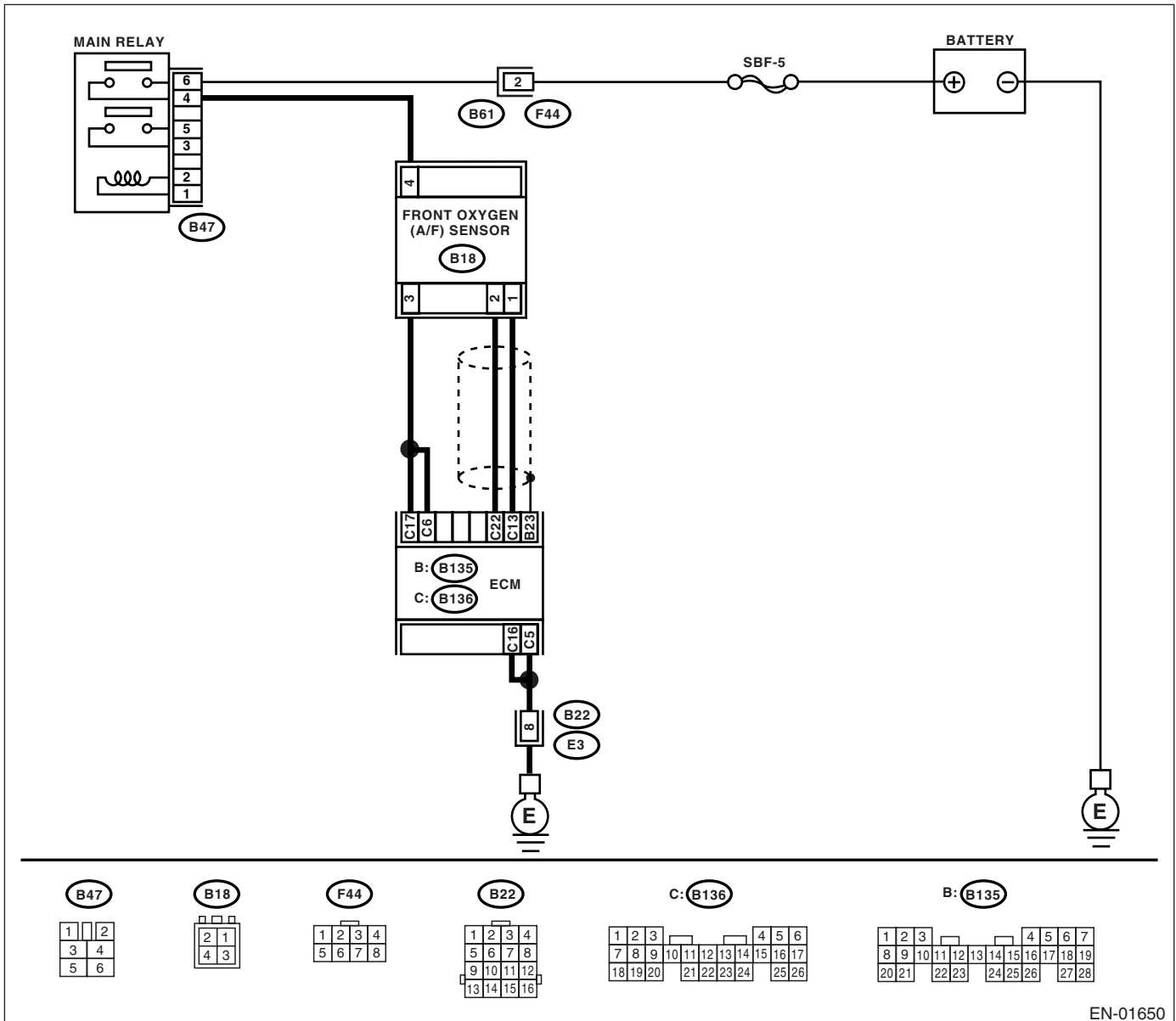

EN-01650

Diagnostic Procedure with Diagnostic Trouble Code (DTC)

ENGINE (DIAGNOSTICS)

	Step	Check	Yes	No
1	CHECK ANY OTHER DTC ON DISPLAY.	Is any other DTC displayed?	Check DTC using the List of Diagnostic Trouble Code (DTC). <Ref. to EN(H4SO)(diag)-71, List of Diagnostic Trouble Code (DTC).> NOTE: It is not necessary to inspect DTC P1134.	Replace the ECM. <Ref. to FU(H4SO)-44, Engine Control Module (ECM).>

Diagnostic Procedure with Diagnostic Trouble Code (DTC)

ENGINE (DIAGNOSTICS)

CV:DTC P1137 O₂ SENSOR CIRCUIT (LAMDA=1) (BANK1 SENSOR1)

DTC DETECTING CONDITION:

- Immediately at fault recognition
- GENERAL DESCRIPTION <Ref. to GD(H4SO)-197, DTC P1137 O₂ SENSOR CIRCUIT LOW VOLTAGE (BANK 1 SENSOR 2), Diagnostic Trouble Code (DTC) Detecting Criteria.>

CAUTION:

After repair or replacement of faulty parts, conduct Clear Memory Mode <Ref. to EN(H4SO)(diag)-44, OPERATION, Clear Memory Mode.> and Inspection Mode <Ref. to EN(H4SO)(diag)-37, OPERATION, Inspection Mode.>.

WIRING DIAGRAM:

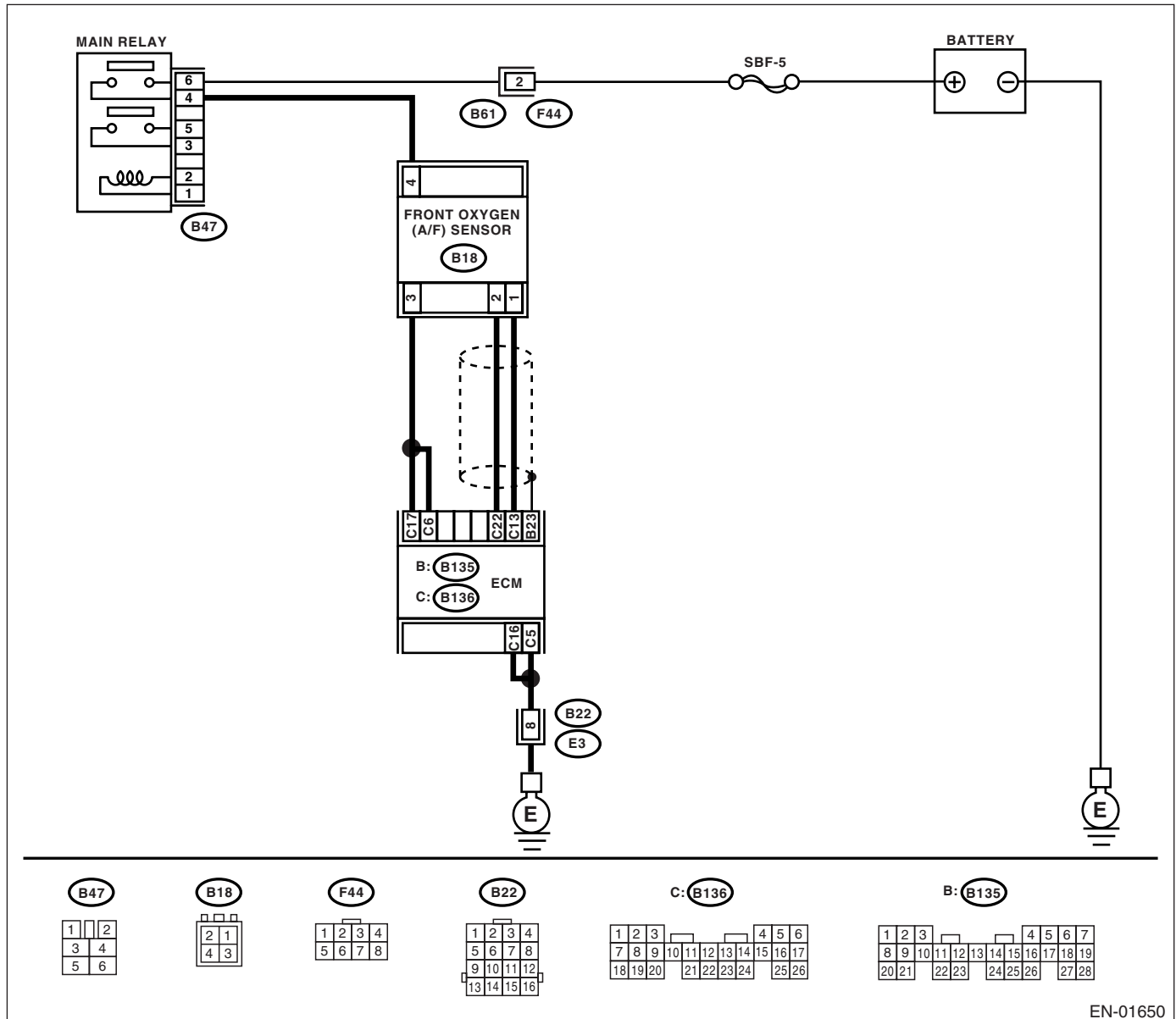

EN-01650

Diagnostic Procedure with Diagnostic Trouble Code (DTC)

ENGINE (DIAGNOSTICS)

Step	Check	Yes	No
<p>1</p> <p>CHECK ANY OTHER DTC ON DISPLAY.</p>	<p>Is any other DTC displayed?</p>	<p>Inspect DTC using "List of Diagnostic Trouble Code (DTC)". <Ref. to EN(H4SO)(diag)-71, List of Diagnostic Trouble Code (DTC).></p>	<p>Go to step 2.</p>
<p>2</p> <p>CHECK FRONT OXYGEN (A/F) SENSOR DATA.</p> <p>1) Start the engine.</p> <p>2) While observing the Subaru Select Monitor or OBD-II general scan tool screen, warm-up the engine until coolant temperature is above 70°C (160°F).</p> <p>If the engine is already warmed-up, operate at idle speed for at least 1 minute.</p> <p>3) Read the data of front oxygen (A/F) sensor signal during idling using Subaru Select Monitor or OBD-II general scan tool.</p> <p>NOTE:</p> <ul style="list-style-type: none"> • Subaru Select Monitor <p>For detailed operation procedure, refer to the "READ CURRENT DATA FOR ENGINE". <Ref. to EN(H4SO)(diag)-30, Subaru Select Monitor.></p> <ul style="list-style-type: none"> • OBD-II general scan tool <p>For detailed operation procedures, refer to the OBD-II General Scan Tool Instruction Manual.</p>	<p>Is the voltage 0.85 — 1.15 V?</p>	<p>Go to step 3.</p>	<p>Go to step 4.</p>
<p>3</p> <p>CHECK FRONT OXYGEN (A/F) SENSOR DATA.</p> <p>Race the engine at speeds from idling to 5,000 rpm for a total of 5 cycles.</p> <p>NOTE:</p> <ul style="list-style-type: none"> • Air fuel ratio is rich at normal condition or during racing. • To increase engine speed to 5,000 rpm, slowly depress accelerator pedal, taking approximately 5 seconds, and quickly release accelerator pedal to decrease engine speed. 	<p>Is the voltage more than 1.1 V?</p>	<p>Go to step 6.</p>	<p>Go to step 4.</p>
<p>4</p> <p>CHECK HARNESS BETWEEN ECM AND FRONT OXYGEN (A/F) SENSOR.</p> <p>1) Turn the ignition switch to OFF.</p> <p>2) Disconnect the connector from ECM and front oxygen (A/F) sensor connector.</p> <p>3) Measure the resistance between ECM and front oxygen (A/F) sensor.</p> <p>Connector & terminals</p> <p>(B136) No. 13 — (B18) No. 1:</p> <p>(B136) No. 22 — (B18) No. 2:</p>	<p>Is the resistance less than 1 Ω?</p>	<p>Go to step 5.</p>	<p>Repair open circuit between ECM and front oxygen (A/F) sensor.</p>
<p>5</p> <p>CHECK HARNESS BETWEEN ECM AND FRONT OXYGEN (A/F) SENSOR.</p> <p>Measure the resistance between ECM and chassis ground.</p> <p>Connector & terminals</p> <p>(B136) No. 13 — Chassis ground:</p> <p>(B136) No. 22 — Chassis ground:</p>	<p>Is the resistance more than 1 MΩ?</p>	<p>Go to step 6.</p>	<p>Repair ground short circuit between ECM and front oxygen (A/F) sensor.</p>

Diagnostic Procedure with Diagnostic Trouble Code (DTC)

ENGINE (DIAGNOSTICS)

Step	Check	Yes	No
6 CHECK EXHAUST SYSTEM. Check exhaust system parts. NOTE: Check the following items. <ul style="list-style-type: none">• Loose installation of portions• Damage (crack, hole etc.) of parts• Looseness of front oxygen (A/F) sensor• Looseness and ill fitting of parts between front oxygen (A/F) sensor and rear oxygen sensor	Is there a fault in exhaust system?	Repair or replace faulty parts.	Replace the front oxygen (A/F) sensor. <Ref. to FU(H4SO)-40, Front Oxygen (A/F) Sensor.>

Diagnostic Procedure with Diagnostic Trouble Code (DTC)

ENGINE (DIAGNOSTICS)

CW:DTC P1400 FUEL TANK PRESSURE CONTROL SOLENOID VALVE CIRCUIT LOW

DTC DETECTING CONDITION:

- Two consecutive driving cycles with fault
- GENERAL DESCRIPTION <Ref. to GD(H4SO)-199, DTC P1400 FUEL TANK PRESSURE CONTROL SOLENOID VALVE CIRCUIT LOW, Diagnostic Trouble Code (DTC) Detecting Criteria.>

CAUTION:

After repair or replacement of faulty parts, conduct CLEAR MEMORY MODE <Ref. to EN(H4SO)(diag)-44, OPERATION, Clear Memory Mode.> and INSPECTION MODE <Ref. to EN(H4SO)(diag)-37, OPERATION, Inspection Mode.>.

WIRING DIAGRAM:

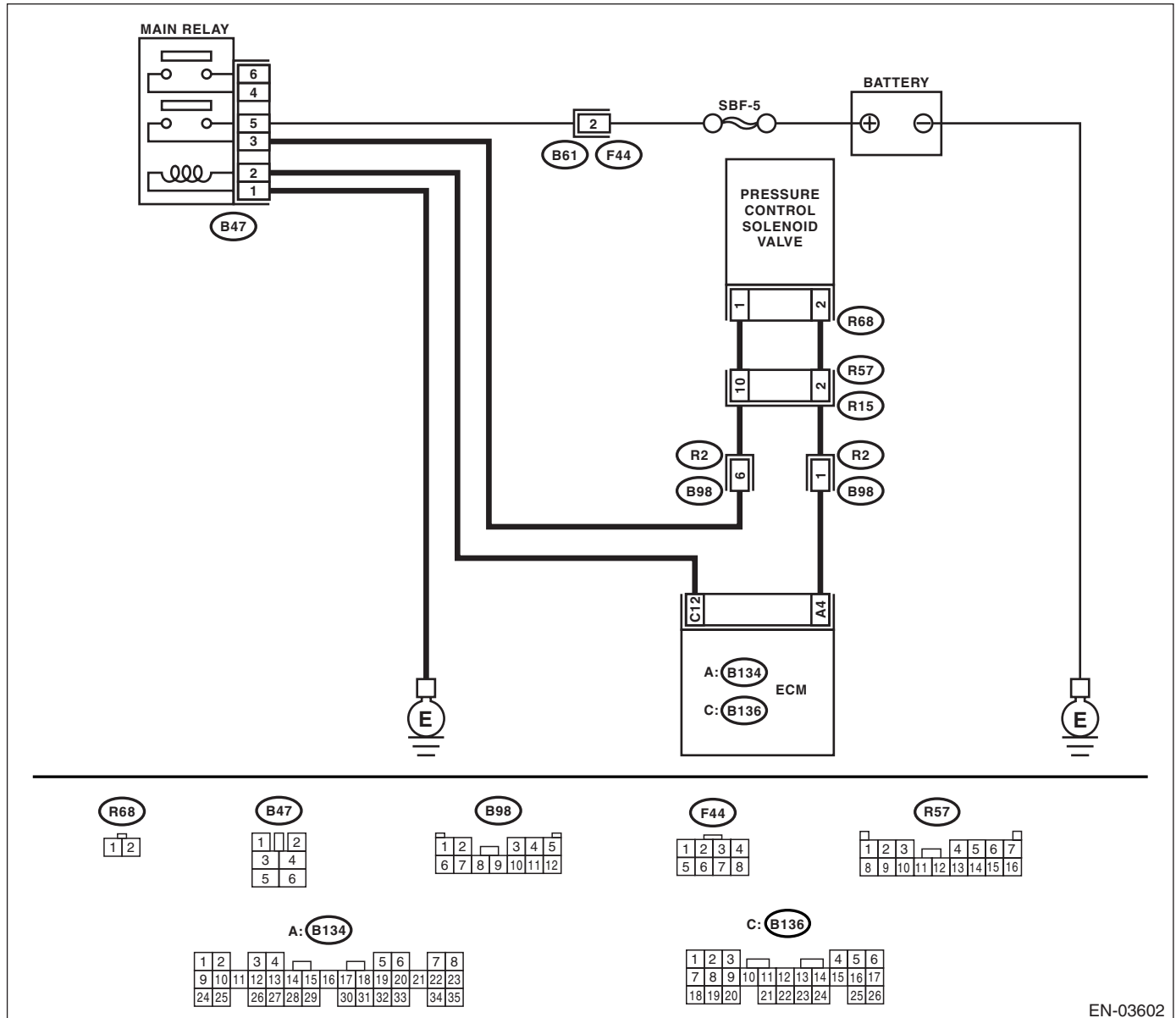

EN-03602

Diagnostic Procedure with Diagnostic Trouble Code (DTC)

ENGINE (DIAGNOSTICS)

Step	Check	Yes	No
1 CHECK OUTPUT SIGNAL FROM ECM. 1) Turn ignition switch to ON. 2) Measure the voltage between ECM and chassis ground. <i>Connector & terminal</i> <i>(B134) No. 4 (+) — Chassis ground (-):</i>	Is the voltage more than 10 V?	Go to step 2.	Go to step 3.
2 CHECK FOR POOR CONTACT. Check for poor contact in ECM connector.	Is there poor contact in ECM connector?	Repair poor contact in ECM connector.	Contact SOA Service Center. NOTE: Inspection by DTM is required, because probable cause is deterioration of multiple parts.
3 CHECK HARNESS BETWEEN PRESSURE CONTROL SOLENOID VALVE AND ECM CONNECTOR. 1) Turn ignition switch to OFF. 2) Disconnect the connectors from pressure control solenoid valve and ECM. 3) Measure the resistance of harness between pressure control solenoid valve connector and chassis ground. <i>Connector & terminal</i> <i>(R68) No. 2 — Chassis ground:</i>	Is the resistance less than 10 Ω ?	Repair short circuit to ground in harness between ECM and pressure control solenoid valve connector.	Go to step 4.
4 CHECK HARNESS BETWEEN PRESSURE CONTROL SOLENOID VALVE AND ECM CONNECTOR. Measure the resistance of harness between ECM and pressure control solenoid valve connector. <i>Connector & terminal</i> <i>(B134) No. 4 — (R68) No. 2:</i>	Is the resistance less than 1 Ω ?	Go to step 5.	Repair harness and connector. NOTE: In this case, repair the following: <ul style="list-style-type: none"> • Open circuit in harness between ECM and pressure control solenoid valve connector • Poor contact in coupling connector
5 CHECK PRESSURE CONTROL SOLENOID VALVE. Measure the resistance between pressure control solenoid valve terminals. <i>Terminals</i> <i>No. 1 — No. 2:</i>	Is the resistance 10 — 100 Ω ?	Go to step 6.	Replace the pressure control solenoid valve. <Ref. to EC(H4SO)-12, Pressure Control Solenoid Valve.>

Diagnostic Procedure with Diagnostic Trouble Code (DTC)

ENGINE (DIAGNOSTICS)

Step	Check	Yes	No
<p>6</p> <p>CHECK POWER SUPPLY TO PRESSURE CONTROL SOLENOID VALVE.</p> <p>1) Turn ignition switch to ON. 2) Measure the voltage between pressure control solenoid valve and chassis ground.</p> <p>Connector & terminal (R68) No. 1 (+) — Chassis ground (-):</p>	<p>Is the voltage more than 10 V?</p>	<p>Go to step 7.</p>	<p>Repair harness and connector.</p> <p>NOTE: In this case, repair the following:</p> <ul style="list-style-type: none"> • Open circuit in harness between main relay and pressure control solenoid valve connector • Poor contact in coupling connector • Poor contact in main relay connector
<p>7</p> <p>CHECK FOR POOR CONTACT.</p> <p>Check for poor contact in pressure control solenoid valve connector.</p>	<p>Is there poor contact in pressure control solenoid valve connector?</p>	<p>Repair poor contact in pressure control solenoid valve connector.</p>	<p>Contact SOA Service Center.</p> <p>NOTE: Inspection by DTM is required, because probable cause is deterioration of multiple parts.</p>

Diagnostic Procedure with Diagnostic Trouble Code (DTC)

ENGINE (DIAGNOSTICS)

CX:DTC P1420 FUEL TANK PRESSURE CONTROL SOLENOID VALVE CIRCUIT HIGH

DTC DETECTING CONDITION:

- Two consecutive driving cycles with fault
- GENERAL DESCRIPTION <Ref. to GD(H4SO)-201, DTC P1420 FUEL TANK PRESSURE CONTROL SOL. VALVE CIRCUIT HIGH, Diagnostic Trouble Code (DTC) Detecting Criteria.>

CAUTION:

After repair or replacement of faulty parts, conduct CLEAR MEMORY MODE <Ref. to EN(H4SO)(diag)-44, OPERATION, Clear Memory Mode.> and INSPECTION MODE <Ref. to EN(H4SO)(diag)-37, OPERATION, Inspection Mode.>.

WIRING DIAGRAM:

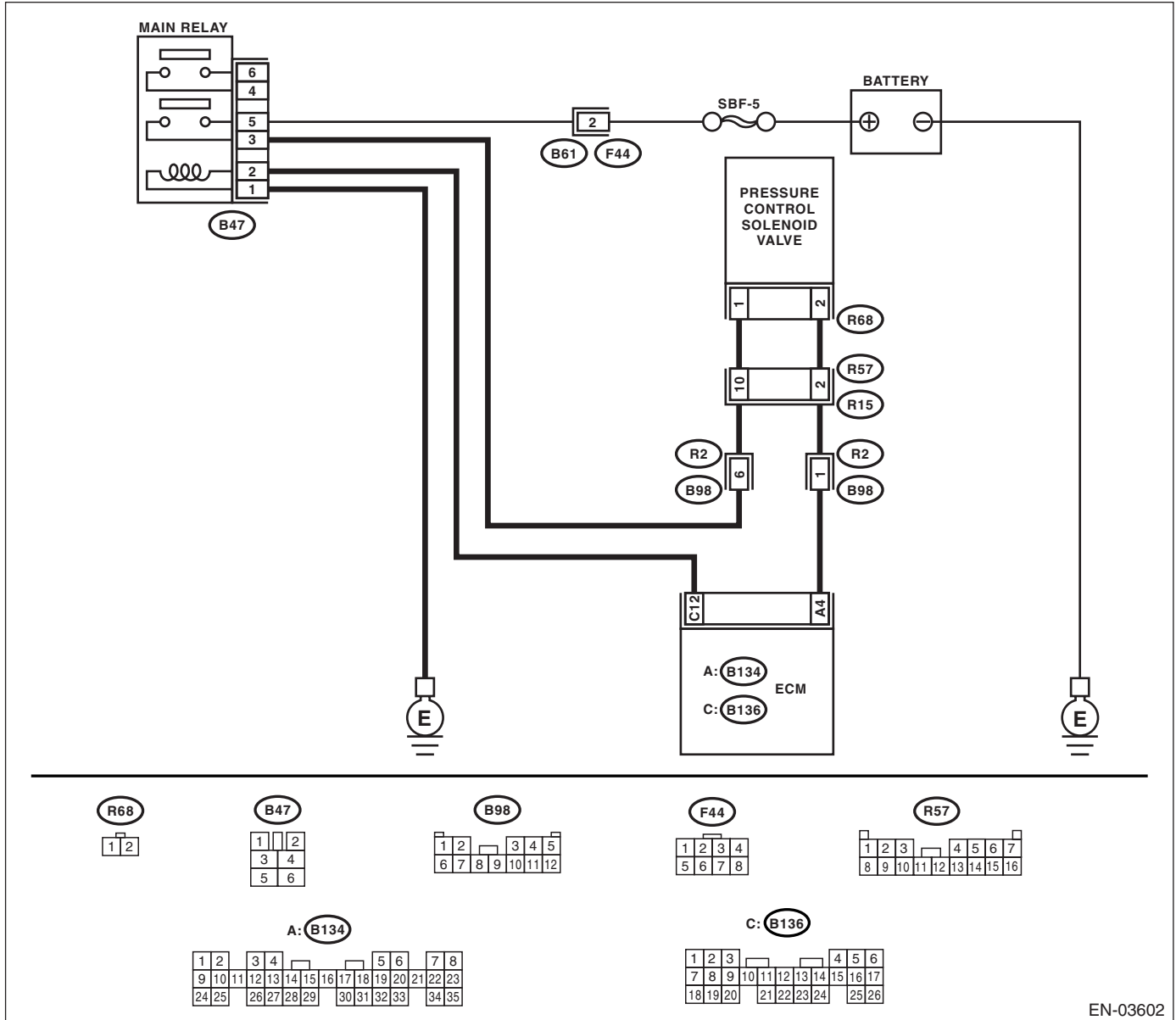

EN-03602

Diagnostic Procedure with Diagnostic Trouble Code (DTC)

ENGINE (DIAGNOSTICS)

Step	Check	Yes	No
<p>1</p> <p>CHECK INPUT SIGNAL FOR ECM. 1) Turn ignition switch to OFF. 2) Connect the test mode connector at the lower portion of instrument panel (on the driver's side). 3) Turn ignition switch to ON. 4) While operating the pressure control solenoid valve, measure voltage between ECM and chassis ground.</p> <p>NOTE: Pressure control solenoid valve operation can be executed using Subaru Select Monitor. For the procedure, refer to "Compulsory Valve Operation Check Mode". <Ref. to EN(H4SO)(diag)-45, Compulsory Valve Operation Check Mode.></p> <p>Connector & terminal (B134) No. 4 (+) — Chassis ground (-):</p>	Is the voltage 0 — 10 V?	Go to step 2.	The malfunction indicator light may light up, however, the circuit is returned to the normal status at the moment. In this case, repair poor contact in ECM connector.
<p>2</p> <p>CHECK INPUT SIGNAL FOR ECM. 1) Turn ignition switch to ON. 2) Measure the voltage between ECM and chassis ground.</p> <p>Connector & terminal (B134) No. 4 (+) — Chassis ground (-):</p>	Is the voltage more than 10 V?	Go to step 4.	Go to step 3.
<p>3</p> <p>CHECK FOR POOR CONTACT. Check for poor contact in ECM connector.</p>	Is there poor contact in ECM connector?	Repair poor contact in ECM connector.	Replace the ECM. <Ref. to FU(H4SO)-44, Engine Control Module (ECM).>
<p>4</p> <p>CHECK HARNESS BETWEEN PRESSURE CONTROL SOLENOID VALVE AND ECM CONNECTOR. 1) Turn ignition switch to OFF. 2) Disconnect the connector from pressure control solenoid valve. 3) Turn ignition switch to ON. 4) Measure the voltage between ECM and chassis ground.</p> <p>Connector & terminal (B134) No. 4 (+) — Chassis ground (-):</p>	Is the voltage more than 10 V?	Repair short circuit to battery in harness between ECM and pressure control solenoid valve connector. After repair, replace the ECM. <Ref. to FU(H4SO)-44, Engine Control Module (ECM).>	Go to step 5.
<p>5</p> <p>CHECK PRESSURE CONTROL SOLENOID VALVE. 1) Turn ignition switch to OFF. 2) Measure the resistance between pressure control solenoid valve terminals.</p> <p>Terminals No. 1 — No. 2:</p>	Is the resistance less than 1 Ω ?	Replace the pressure control solenoid valve <Ref. to EC(H4SO)-12, Pressure Control Solenoid Valve.> and the ECM <Ref. to FU(H4SO)-44, Engine Control Module (ECM).>.	Go to step 6.
<p>6</p> <p>CHECK FOR POOR CONTACT. Check for poor contact in ECM connector.</p>	Is there poor contact in ECM connector?	Repair poor contact in ECM connector.	Replace the ECM. <Ref. to FU(H4SO)-44, Engine Control Module (ECM).>

Diagnostic Procedure with Diagnostic Trouble Code (DTC)

ENGINE (DIAGNOSTICS)

CY:DTC P1443 VENT CONTROL SOLENOID VALVE FUNCTION PROBLEM

DTC DETECTING CONDITION:

- Immediately at fault recognition
- GENERAL DESCRIPTION <Ref. to GD(H4SO)-202, DTC P1443 VENT CONTROL SOLENOID VALVE FUNCTION PROBLEM, Diagnostic Trouble Code (DTC) Detecting Criteria.>

TROUBLE SYMPTOM:

Improper fuel supply

CAUTION:

After repair or replacement of faulty parts, conduct CLEAR MEMORY MODE <Ref. to EN(H4SO)(diag)-44, OPERATION, Clear Memory Mode.> and INSPECTION MODE <Ref. to EN(H4SO)(diag)-37, OPERATION, Inspection Mode.>.

WIRING DIAGRAM:

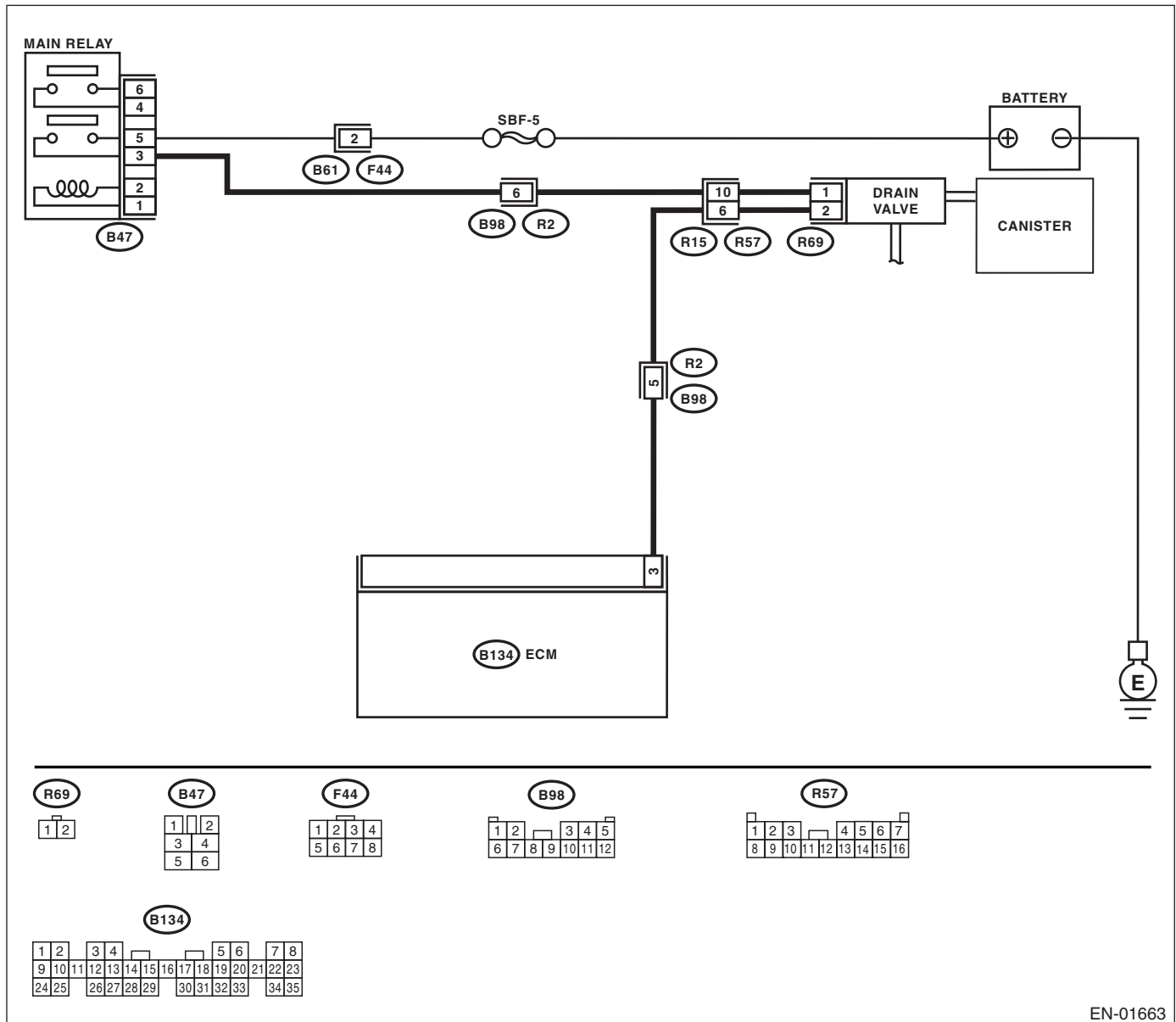

EN-01663

Diagnostic Procedure with Diagnostic Trouble Code (DTC)

ENGINE (DIAGNOSTICS)

	Step	Check	Yes	No
1	CHECK FOR OTHER DTC ON DISPLAY.	Is any other DTC displayed?	Inspect the relevant DTC using "List of Diagnostic Trouble Code (DTC)". <Ref. to EN(H4SO)(diag)-71, List of Diagnostic Trouble Code (DTC).>	Go to step 2.
2	CHECK VENT LINE HOSES. Check the following items. <ul style="list-style-type: none"> • Clogging of vent hoses between canister and drain valve • Clogging of vent hose between drain valve and air filter • Clogging of drain filter 	Is there a fault in vent line?	Repair or replace faulty parts.	Go to step 3.
3	CHECK DRAIN VALVE OPERATION. 1) Turn ignition switch to OFF. 2) Connect the test mode connector at the lower portion of instrument panel (on the driver's side). 3) Turn ignition switch to ON. 4) Operate the drain valve. NOTE: Drain valve operation can also be executed using Subaru Select Monitor. For the procedure, refer to "Compulsory Valve Operation Check Mode". <Ref. to EN(H4SO)(diag)-45, Compulsory Valve Operation Check Mode.>	Does the drain valve operate?	Contact SOA Service Center. NOTE: Inspection by DTM is required, because probable cause is deterioration of multiple parts.	Replace the drain valve. <Ref. to EC(H4SO)-18, Drain Valve.>

Diagnostic Procedure with Diagnostic Trouble Code (DTC)

ENGINE (DIAGNOSTICS)

CZ:DTC P1446 FUEL TANK SENSOR CONTROL VALVE CIRCUIT LOW

DTC DETECTING CONDITION:

- Two consecutive driving cycles with fault
- GENERAL DESCRIPTION <Ref. to GD(H4SO)-203, DTC P1446 FUEL TANK SENSOR CONTROL VALVE CIRCUIT LOW, Diagnostic Trouble Code (DTC) Detecting Criteria.>

CAUTION:

After repair or replacement of faulty parts, conduct CLEAR MEMORY MODE <Ref. to EN(H4SO)(diag)-44, OPERATION, Clear Memory Mode.> and INSPECTION MODE <Ref. to EN(H4SO)(diag)-37, OPERATION, Inspection Mode.>.

WIRING DIAGRAM:

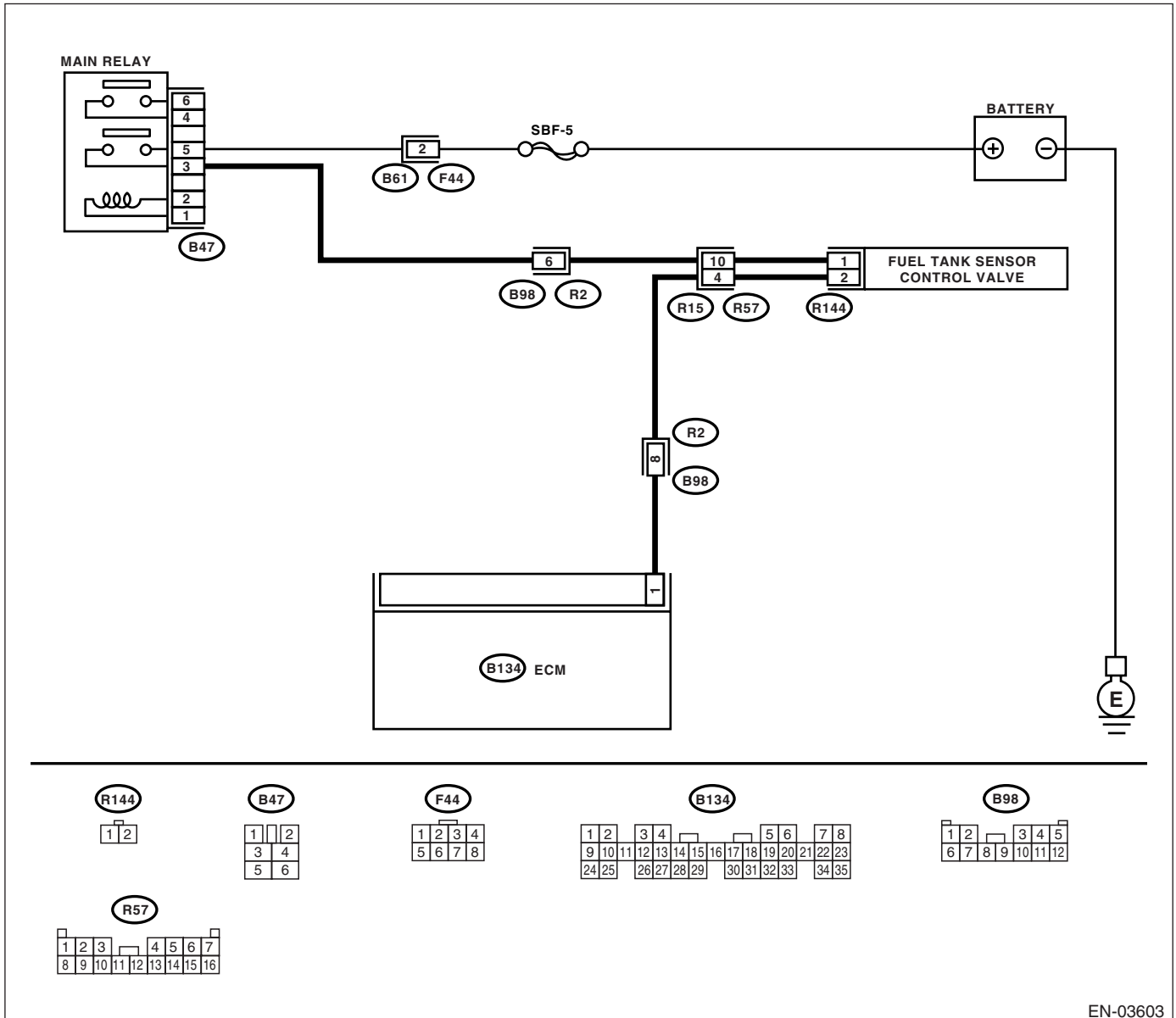

EN-03603

Diagnostic Procedure with Diagnostic Trouble Code (DTC)

ENGINE (DIAGNOSTICS)

Step	Check	Yes	No
1 CHECK OUTPUT SIGNAL FROM ECM. 1) Turn ignition switch to ON. 2) Measure the voltage between ECM and chassis ground. Connector & terminal (B134) No. 1 (+) — Chassis ground (-):	Is the voltage more than 10 V?	Go to step 2.	Go to step 3.
2 CHECK FOR POOR CONTACT. Check for poor contact in ECM connector.	Is there poor contact in ECM connector?	Repair poor contact in ECM connector.	The malfunction indicator light may light up, however, the circuit is returned to the normal status at the moment. (However, the possibility of poor contact still remains.) NOTE: In this case, repair the following: <ul style="list-style-type: none"> • Poor contact in fuel tank sensor control valve connector • Poor contact in ECM connector • Poor contact in coupling connector
3 CHECK HARNESS BETWEEN FUEL TANK SENSOR CONTROL VALVE AND ECM CONNECTOR. 1) Turn ignition switch to OFF. 2) Disconnect the connectors from fuel tank sensor control valve and ECM. 3) Measure the resistance of harness between fuel tank sensor control valve connector and chassis ground. Connector & terminal (R144) No. 2 — Chassis ground:	Is the resistance more than 1 M Ω ?	Go to step 4.	Repair short circuit to ground in harness between ECM and fuel tank sensor control valve connector.
4 CHECK HARNESS BETWEEN FUEL TANK SENSOR CONTROL VALVE AND ECM CONNECTOR. Measure the resistance of harness between ECM and fuel tank sensor control valve connector. Connector & terminal (B134) No. 1 — (R144) No. 2:	Is the resistance less than 1 Ω ?	Go to step 5.	Repair harness and connector. NOTE: In this case, repair the following: <ul style="list-style-type: none"> • Open circuit in harness between ECM and fuel tank sensor control valve connector • Poor contact in coupling connector
5 CHECK FUEL TANK SENSOR CONTROL VALVE. Measure the resistance between fuel tank sensor control valve terminals. Terminals No. 1 — No. 2:	Is the resistance 10 — 100 Ω ?	Go to step 6.	Replace the fuel tank sensor control valve. <Ref. to EC(H4SO)-18, Drain Valve.>

Diagnostic Procedure with Diagnostic Trouble Code (DTC)

ENGINE (DIAGNOSTICS)

Step	Check	Yes	No
<p>6</p> <p>CHECK POWER SUPPLY TO FUEL TANK SENSOR CONTROL VALVE. 1) Turn ignition switch to ON. 2) Measure the voltage between fuel tank sensor control valve and chassis ground.</p> <p>Connector & terminal (R144) No. 1 (+) — Chassis ground (-):</p>	Is the voltage more than 10 V?	Go to step 7.	Repair harness and connector. NOTE: In this case, repair the following: <ul style="list-style-type: none"> • Open circuit in harness between main relay and fuel tank sensor control valve • Poor contact in coupling connector • Poor contact in main relay connector
<p>7</p> <p>CHECK FOR POOR CONTACT. Check for poor contact in fuel tank sensor control valve connector.</p>	Is there poor contact in fuel tank sensor control valve connector?	Repair poor contact in fuel tank sensor control valve connector.	Contact SOA Service Center. NOTE: Inspection by DTM is required, because probable cause is deterioration of multiple parts.

Diagnostic Procedure with Diagnostic Trouble Code (DTC)

ENGINE (DIAGNOSTICS)

DA:DTC P1447 FUEL TANK SENSOR CONTROL VALVE CIRCUIT HIGH

DTC DETECTING CONDITION:

- Two consecutive driving cycles with fault
- GENERAL DESCRIPTION <Ref. to GD(H4SO)-205, DTC P1447 FUEL TANK SENSOR CONTROL VALVE CIRCUIT HIGH, Diagnostic Trouble Code (DTC) Detecting Criteria.>

CAUTION:

After repair or replacement of faulty parts, conduct CLEAR MEMORY MODE <Ref. to EN(H4SO)(diag)-44, OPERATION, Clear Memory Mode.> and INSPECTION MODE <Ref. to EN(H4SO)(diag)-37, OPERATION, Inspection Mode.>.

WIRING DIAGRAM:

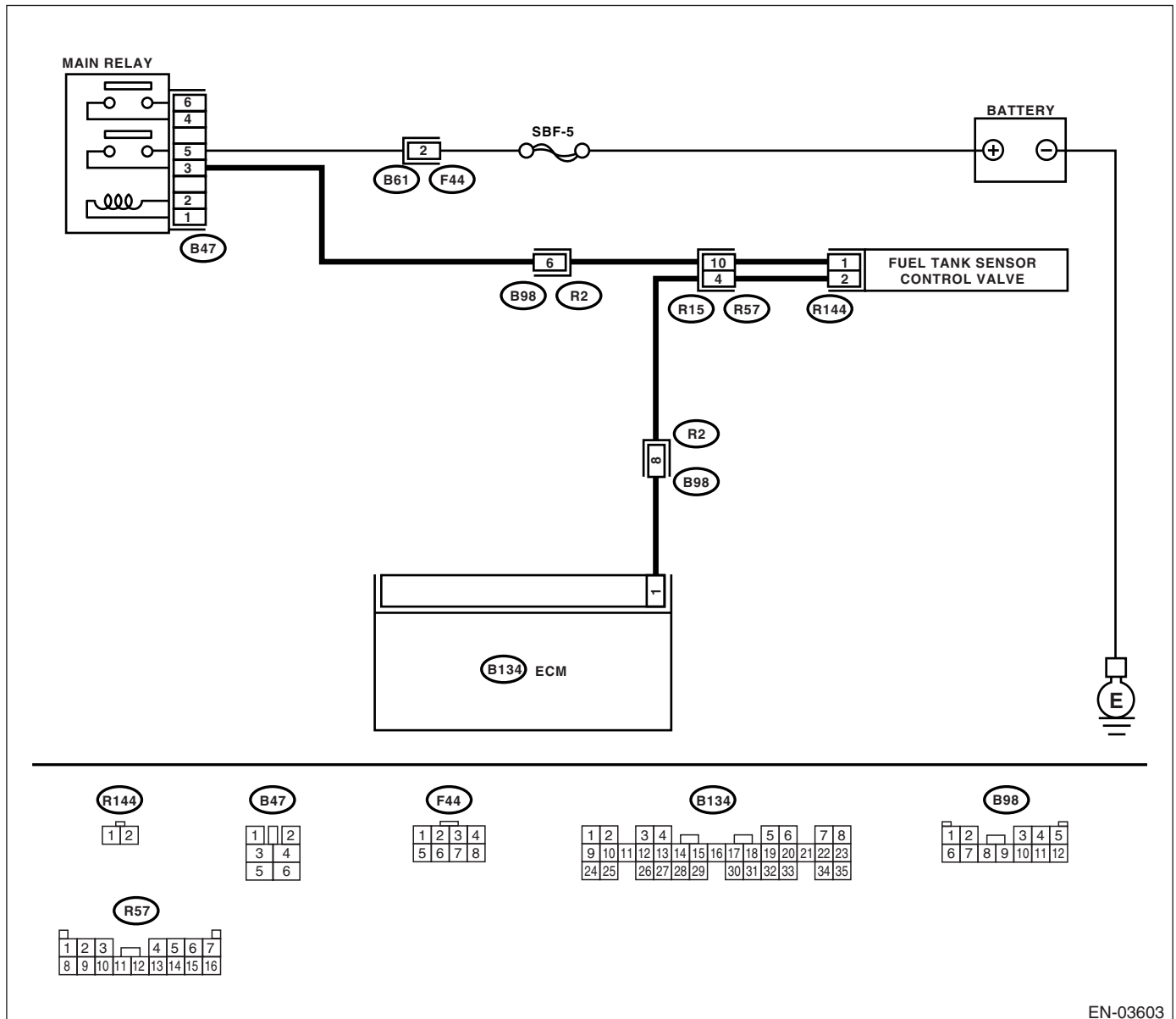

EN-03603

Diagnostic Procedure with Diagnostic Trouble Code (DTC)

ENGINE (DIAGNOSTICS)

Step	Check	Yes	No
1 CHECK OUTPUT SIGNAL FROM ECM. 1) Turn ignition switch to ON. 2) Measure the voltage between ECM and chassis ground. Connector & terminal (B134) No. 1 (+) — Chassis ground (-):	Is the voltage more than 10 V?	Go to step 3.	Go to step 2.
2 CHECK FOR POOR CONTACT. Check for poor contact in ECM connector.	Is there poor contact in ECM connector?	Repair poor contact in ECM connector.	Replace the ECM. <Ref. to FU(H4SO)-44, Engine Control Module (ECM).>
3 CHECK HARNESS BETWEEN FUEL TANK SENSOR CONTROL VALVE AND ECM CONNECTOR. 1) Turn ignition switch to OFF. 2) Disconnect the connector from fuel tank sensor control valve. 3) Turn ignition switch to ON. 4) Measure the voltage between ECM and chassis ground. Connector & terminal (B134) No. 1 (+) — Chassis ground (-):	Is the voltage more than 10 V?	Repair short circuit to battery in harness between ECM and fuel tank sensor control valve connector. After repair, replace the ECM. <Ref. to FU(H4SO)-44, Engine Control Module (ECM).>	Go to step 4.
4 CHECK FUEL TANK SENSOR CONTROL VALVE. 1) Turn ignition switch to OFF. 2) Measure the resistance between fuel tank sensor control valve terminals. Terminals No. 1 — No. 2:	Is the resistance less than 1 Ω ?	Replace the fuel tank sensor control valve <Ref. to EC(H4SO)-18, Drain Valve.> and the ECM <Ref. to FU(H4SO)-44, Engine Control Module (ECM).>.	Go to step 5.
5 CHECK FOR POOR CONTACT. Check for poor contact in ECM connector.	Is there poor contact in ECM connector?	Repair poor contact in ECM connector.	Replace the ECM. <Ref. to FU(H4SO)-44, Engine Control Module (ECM).>

Diagnostic Procedure with Diagnostic Trouble Code (DTC)

ENGINE (DIAGNOSTICS)

DB:DTC P1448 FUEL TANK SENSOR CONTROL VALVE RANGE/PERFORMANCE PROBLEM

DTC DETECTING CONDITION:

- Two consecutive driving cycles with fault
- GENERAL DESCRIPTION <Ref. to GD(H4SO)-207, DTC P1448 FUEL TANK SENSOR CONTROL VALVE RANGE/PERFORMANCE, Diagnostic Trouble Code (DTC) Detecting Criteria.>

CAUTION:

After repair or replacement of faulty parts, conduct CLEAR MEMORY MODE <Ref. to EN(H4SO)(diag)-44, OPERATION, Clear Memory Mode.> and INSPECTION MODE <Ref. to EN(H4SO)(diag)-37, OPERATION, Inspection Mode.>.

WIRING DIAGRAM:

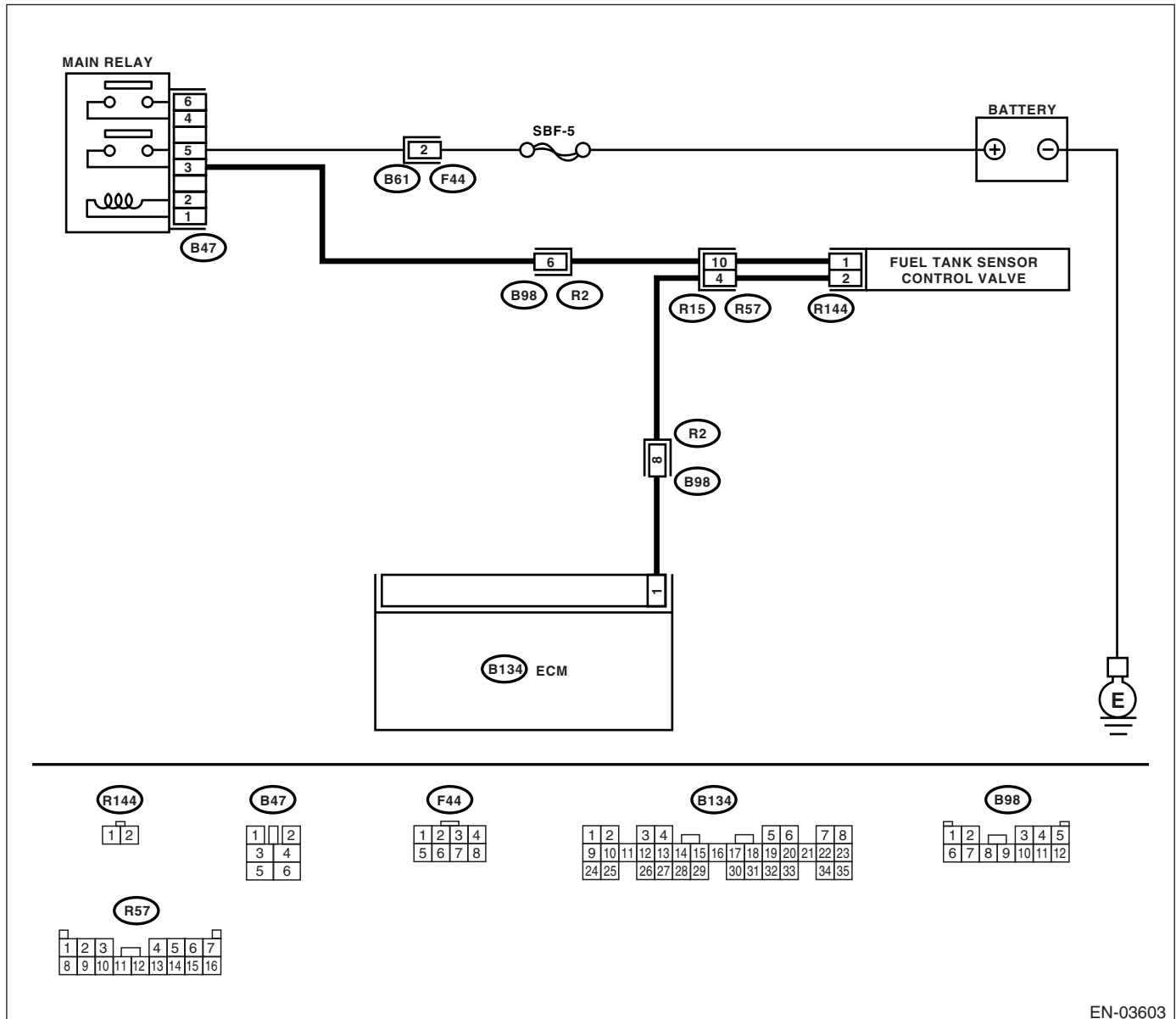

EN-03603

Diagnostic Procedure with Diagnostic Trouble Code (DTC)

ENGINE (DIAGNOSTICS)

	Step	Check	Yes	No
1	CHECK FOR OTHER DTC ON DISPLAY.	Is any other DTC displayed?	Inspect the relevant DTC using the "List of Diagnostic Trouble Code (DTC)". <Ref. to EN(H4SO)(diag)-71, List of Diagnostic Trouble Code (DTC).>	Go to step 2.
2	CHECK FUEL FILLER CAP. 1) Turn ignition switch to OFF. 2) Open the fuel flap.	Is the fuel filler cap tightened securely?	Go to step 3.	Tighten fuel filler cap securely.
3	CHECK EVAPORATIVE EMISSION LINE. NOTE: Check the following items. <ul style="list-style-type: none">• Disconnection, leakage and clogging of hoses between fuel tank pressure sensor and fuel tank.• Disconnection, leakage and clogging of hoses and pipes between fuel filler pipe and fuel tank.	Is there any trouble in evaporation line?	Repair the hoses and pipes.	Replace the fuel tank pressure sensor.

**DC:DTC P1510 ISC SOLENOID VALVE SIGNAL #1 CIRCUIT MALFUNCTION
(LOW INPUT)**

NOTE:

For the diagnostic procedure, refer to DTC P1516. <Ref. to EN(H4SO)(diag)-280, DTC P1516 ISC SOLENOID VALVE SIGNAL #4 CIRCUIT MALFUNCTION (LOW INPUT), Diagnostic Procedure with Diagnostic Trouble Code (DTC).>

**DD:DTC P1511 ISC SOLENOID VALVE SIGNAL #1 CIRCUIT MALFUNCTION
(HIGH INPUT)**

NOTE:

For the diagnostic procedure, refer to DTC P1517. <Ref. to EN(H4SO)(diag)-282, DTC P1517 ISC SOLENOID VALVE SIGNAL #4 CIRCUIT MALFUNCTION (HIGH INPUT), Diagnostic Procedure with Diagnostic Trouble Code (DTC).>

**DE:DTC P1512 ISC SOLENOID VALVE SIGNAL #2 CIRCUIT MALFUNCTION
(LOW INPUT)**

NOTE:

For the diagnostic procedure, refer to DTC P1516. <Ref. to EN(H4SO)(diag)-280, DTC P1516 ISC SOLENOID VALVE SIGNAL #4 CIRCUIT MALFUNCTION (LOW INPUT), Diagnostic Procedure with Diagnostic Trouble Code (DTC).>

**DF:DTC P1513 ISC SOLENOID VALVE SIGNAL #2 CIRCUIT MALFUNCTION
(HIGH INPUT)**

NOTE:

For the diagnostic procedure, refer to DTC P1517. <Ref. to EN(H4SO)(diag)-282, DTC P1517 ISC SOLENOID VALVE SIGNAL #4 CIRCUIT MALFUNCTION (HIGH INPUT), Diagnostic Procedure with Diagnostic Trouble Code (DTC).>

**DG:DTC P1514 ISC SOLENOID VALVE SIGNAL #3 CIRCUIT MALFUNCTION
(LOW INPUT)**

NOTE:

For the diagnostic procedure, refer to DTC P1516. <Ref. to EN(H4SO)(diag)-280, DTC P1516 ISC SOLENOID VALVE SIGNAL #4 CIRCUIT MALFUNCTION (LOW INPUT), Diagnostic Procedure with Diagnostic Trouble Code (DTC).>

**DH:DTC P1515 ISC SOLENOID VALVE SIGNAL #3 CIRCUIT MALFUNCTION
(HIGH INPUT)**

NOTE:

For the diagnostic procedure, refer to DTC P1517. <Ref. to EN(H4SO)(diag)-282, DTC P1517 ISC SOLENOID VALVE SIGNAL #4 CIRCUIT MALFUNCTION (HIGH INPUT), Diagnostic Procedure with Diagnostic Trouble Code (DTC).>

Diagnostic Procedure with Diagnostic Trouble Code (DTC)

ENGINE (DIAGNOSTICS)

DI: DTC P1516 ISC SOLENOID VALVE SIGNAL #4 CIRCUIT MALFUNCTION (LOW INPUT)

DTC DETECTING CONDITION:

- Immediately at fault recognition
- GENERAL DESCRIPTION <Ref. to GD(H4SO)-222, DTC P1516 ISC SOLENOID VALVE SIGNAL #4 CIRCUIT MALFUNCTION (LOW INPUT), Diagnostic Trouble Code (DTC) Detecting Criteria.>

TROUBLE SYMPTOM:

- Erroneous idling
- Engine stalls.
- Engine breathing

CAUTION:

After repair or replacement of faulty parts, conduct Clear Memory Mode <Ref. to EN(H4SO)(diag)-44, OPERATION, Clear Memory Mode.> and Inspection Mode <Ref. to EN(H4SO)(diag)-37, OPERATION, Inspection Mode.>.

WIRING DIAGRAM:

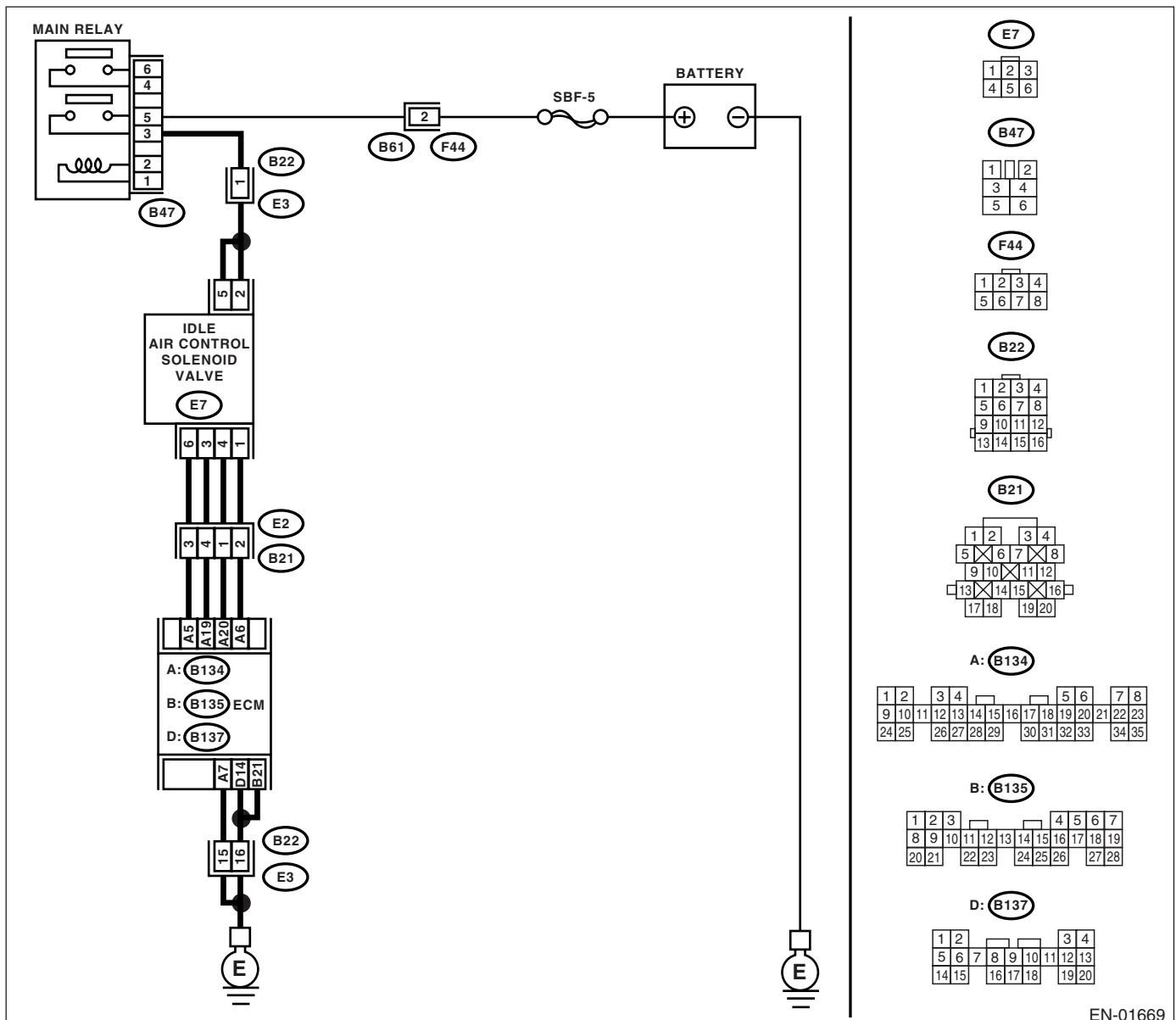

EN-01669

Diagnostic Procedure with Diagnostic Trouble Code (DTC)

ENGINE (DIAGNOSTICS)

Step	Check	Yes	No
<p>1 CHECK POWER SUPPLY TO IDLE AIR CONTROL SOLENOID VALVE.</p> <p>1) Turn the ignition switch to OFF. 2) Disconnect the connector from idle air control solenoid valve. 3) Turn the ignition switch to ON. 4) Measure the voltage between idle air control solenoid valve connector and engine ground.</p> <p>Connector & terminal (E7) No. 2 (+) — Engine ground (-): (E7) No. 5 (+) — Engine ground (-):</p>	Is the voltage more than 10 V?	Go to step 2.	Repair harness and connector. NOTE: In this case, repair the following: • Open circuit in harness between idle air control solenoid valve and main relay connector • Poor contact in coupling connector
<p>2 CHECK HARNESS BETWEEN ECM AND IDLE AIR CONTROL SOLENOID VALVE CONNECTOR.</p> <p>1) Turn the ignition switch to OFF. 2) Measure the resistance between ECM and idle air control solenoid valve connector.</p> <p>Connector & terminal DTC P1510; (B134) No. 20 — (E7) No. 4: DTC P1512; (B134) No. 6 — (E7) No. 1: DTC P1514; (B134) No. 5 — (E7) No. 6: DTC P1516; (B134) No. 19 — (E7) No. 3:</p>	Is the resistance less than 1 Ω?	Go to step 3.	Repair harness and connector. NOTE: In this case, repair the following: • Open circuit in harness between ECM and idle air control solenoid valve connector • Poor contact in coupling connector
<p>3 CHECK HARNESS BETWEEN ECM AND IDLE AIR CONTROL SOLENOID VALVE CONNECTOR.</p> <p>1) Disconnect the connector from ECM. 2) Measure the resistance between ECM connector and chassis ground.</p> <p>Connector & terminal DTC P1510; (B134) No. 20 — Chassis ground: DTC P1512; (B134) No. 6 — Chassis ground: DTC P1514; (B134) No. 5 — Chassis ground: DTC P1516; (B134) No. 19 — Chassis ground:</p>	Is the resistance more than 1 MΩ?	Go to step 4.	Repair ground short circuit in harness between ECM and idle air control solenoid valve connector.
<p>4 CHECK POOR CONTACT.</p> <p>Check poor contact in ECM connector and idle air control solenoid valve connector.</p>	Is there poor contact in ECM connector or idle air control solenoid valve connector?	Repair poor contact in ECM connector or idle air control solenoid valve connector.	Replace the idle air control solenoid valve. <Ref. to FU(H4SO)-32, Idle Air Control Solenoid Valve.>

Diagnostic Procedure with Diagnostic Trouble Code (DTC)

ENGINE (DIAGNOSTICS)

Step	Check	Yes	No
1 CHECK ANY OTHER DTC ON DISPLAY.	Is any other DTC displayed?	Check the DTC using the List of Diagnostic Trouble Code (DTC). <Ref. to EN(H4SO)(diag)-71, List of Diagnostic Trouble Code (DTC).>	Go to step 2.
2 CHECK GROUND CIRCUIT FOR ECM. 1) Turn the ignition switch to OFF. 2) Measure the resistance between ECM connector and chassis ground. Connector & terminal (B134) No. 7 — Chassis ground: (B137) No. 14 — Chassis ground: (B135) No. 21 — Chassis ground:	Is the resistance less than 5 Ω?	Go to step 3.	Repair harness and connector. NOTE: In this case, repair the following: • Open circuit in harness between ECM connector and engine ground terminal • Poor contact in ECM connector • Poor contact in coupling connector
3 CHECK HARNESS BETWEEN ECM AND IDLE AIR CONTROL SOLENOID VALVE CONNECTOR. 1) Turn the ignition switch to OFF. 2) Disconnect the connector from idle air control solenoid valve. 3) Turn the ignition switch to ON. 4) Measure the voltage between ECM connector and chassis ground. Connector & terminal DTC P1511; (B134) No. 20 (+) — Chassis ground (-): DTC P1513; (B134) No. 6 (+) — Chassis ground (-): DTC P1515; (B134) No. 5 (+) — Chassis ground (-): DTC P1517; (B134) No. 19 (+) — Chassis ground (-):	Is the voltage more than 10 V?	Repair battery short circuit in harness between ECM and idle air control solenoid valve connector. After repair, replace the ECM. <Ref. to FU(H4SO)-44, Engine Control Module (ECM).>	Replace the ECM. <Ref. to FU(H4SO)-44, Engine Control Module (ECM).>

DK:DTC P1518 STARTER SWITCH CIRCUIT LOW INPUT

DTC DETECTING CONDITION:

- Two consecutive driving cycles with fault
- GENERAL DESCRIPTION <Ref. to GD(H4SO)-226, DTC P1518 STARTER SWITCH CIRCUIT LOW INPUT, Diagnostic Trouble Code (DTC) Detecting Criteria.>

TROUBLE SYMPTOM:

Failure of engine to start

CAUTION:

After repair or replacement of faulty parts, conduct Clear Memory Mode <Ref. to EN(H4SO)(diag)-44, OPERATION, Clear Memory Mode.> and Inspection Mode <Ref. to EN(H4SO)(diag)-37, OPERATION, Inspection Mode.>.

Diagnostic Procedure with Diagnostic Trouble Code (DTC)

ENGINE (DIAGNOSTICS)

WIRING DIAGRAM:

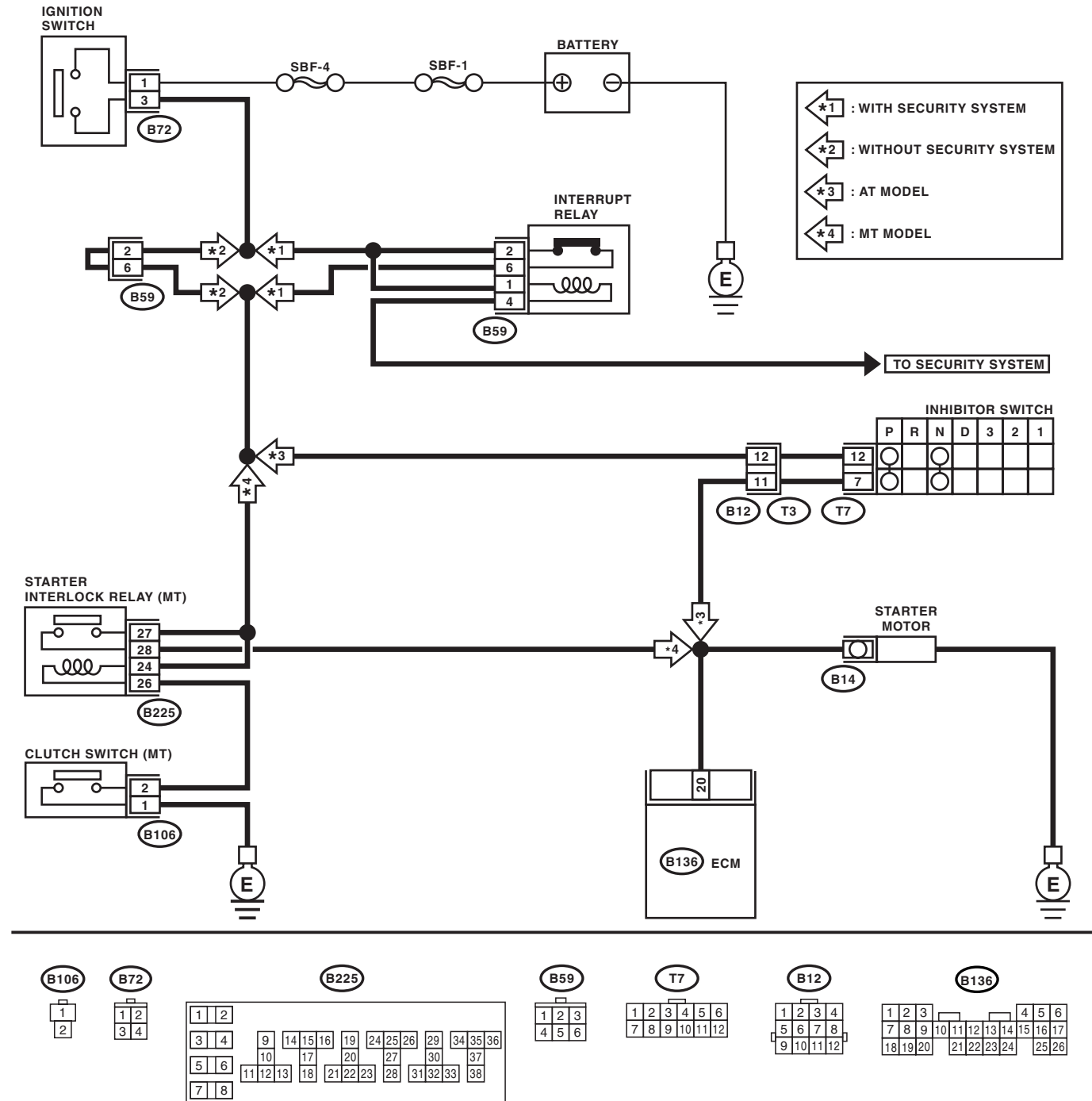

EN-01645

Diagnostic Procedure with Diagnostic Trouble Code (DTC)

ENGINE (DIAGNOSTICS)

Step	Check	Yes	No
1 CHECK OPERATION OF STARTER MOTOR. Place the inhibitor switch in the "P" or "N" range. (AT model) Depress the clutch pedal. (MT model)	Does the starter motor operate when ignition switch is turned to "ST"?	Repair harness and connector. NOTE: In this case, repair the following: <ul style="list-style-type: none">• Open or ground short circuit in harness between ECM and starter motor connector.• Poor contact in ECM connector.	Check starter motor circuit. <Ref. to EN(H4SO)(diag)-57, STARTER MOTOR CIRCUIT, Diagnostics for Engine Starting Failure.>

Diagnostic Procedure with Diagnostic Trouble Code (DTC)

ENGINE (DIAGNOSTICS)

DL:DTC P1560 BACK-UP VOLTAGE CIRCUIT MALFUNCTION

DTC DETECTING CONDITION:

- Immediately at fault recognition
- GENERAL DESCRIPTION <Ref. to GD(H4SO)-227, DTC P1560 BACK-UP VOLTAGE CIRCUIT MALFUNCTION, Diagnostic Trouble Code (DTC) Detecting Criteria.>

CAUTION:

After repair or replacement of faulty parts, conduct Clear Memory Mode <Ref. to EN(H4SO)(diag)-44, OPERATION, Clear Memory Mode.> and Inspection Mode <Ref. to EN(H4SO)(diag)-37, OPERATION, Inspection Mode.>.

WIRING DIAGRAM:

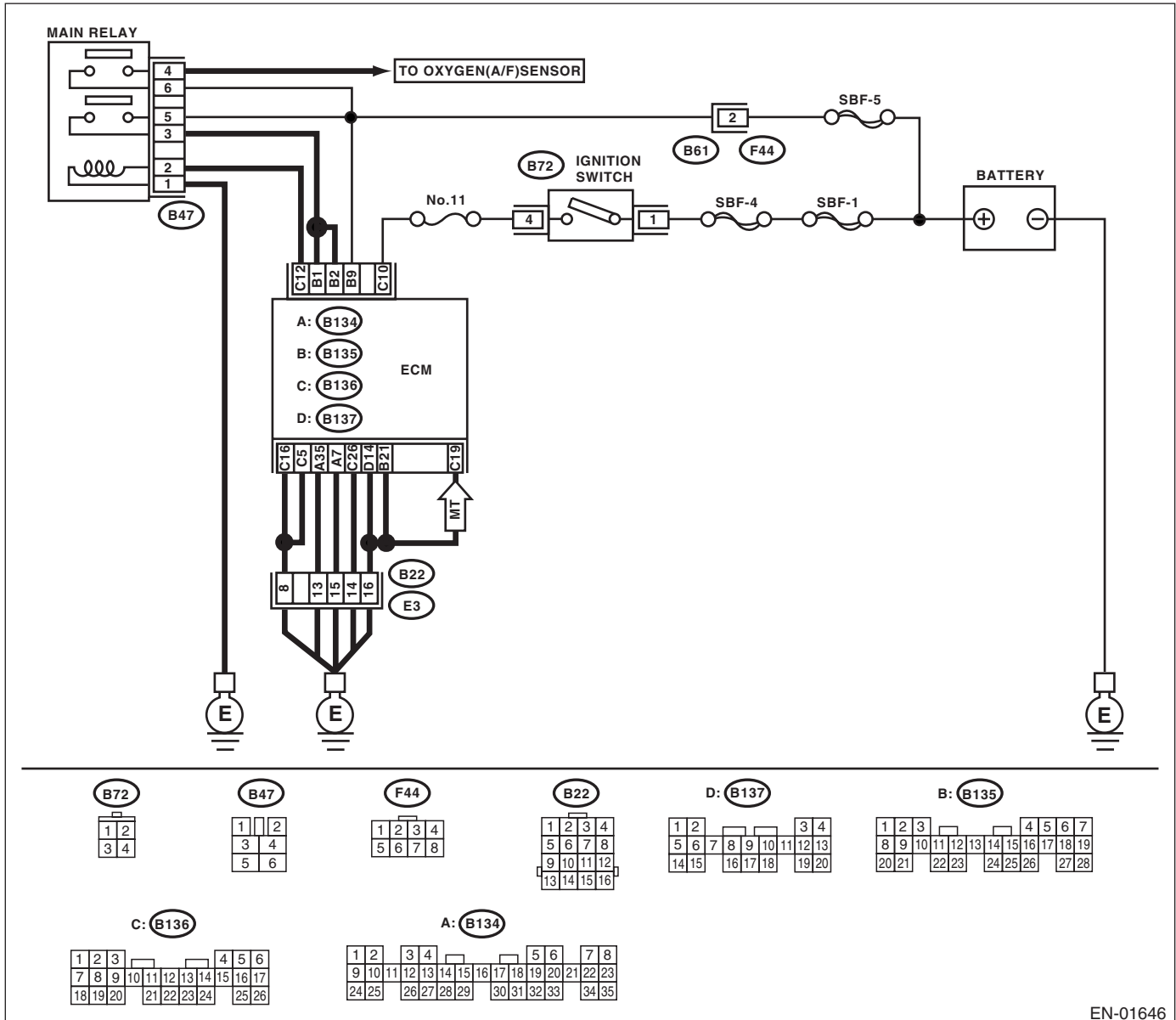

EN-01646

Diagnostic Procedure with Diagnostic Trouble Code (DTC)

ENGINE (DIAGNOSTICS)

Step	Check	Yes	No
1 CHECK INPUT SIGNAL FOR ECM. 1) Turn the ignition switch to OFF. 2) Measure the voltage between ECM and chassis ground. <i>Connector & terminal</i> <i>(B135) No. 9 (+) — Chassis ground (-):</i>	Is the voltage more than 10 V?	Repair poor contact in ECM connector.	Go to step 2.
2 CHECK HARNESS BETWEEN ECM AND MAIN FUSE BOX CONNECTOR. 1) Disconnect the connector from ECM. 2) Measure the resistance of harness between ECM and chassis ground. <i>Connector & terminal</i> <i>(B135) No. 9 — Chassis ground:</i>	Is the resistance less than 10 Ω ?	Repair ground short circuit in harness between ECM connector and battery terminal.	Go to step 3.
3 CHECK FUSE SBF-5.	Is the fuse blown out?	Replace the fuse.	Repair harness and connector. NOTE: In this case, repair the following: <ul style="list-style-type: none"> • Open circuit in harness between ECM and battery • Poor contact in ECM connector • Poor contact in battery terminal

Diagnostic Procedure with Diagnostic Trouble Code (DTC)

ENGINE (DIAGNOSTICS)

DM:DTC P1698 ENGINE TORQUE CONTROL CUT SIGNAL CIRCUIT LOW INPUT DTC DETECTING CONDITION:

- Two consecutive driving cycles with fault
- GENERAL DESCRIPTION <Ref. to GD(H4SO)-228, DTC P1698 ENGINE TORQUE CONTROL CUT SIGNAL CIRCUIT MALFUNCTION (LOW INPUT), Diagnostic Trouble Code (DTC) Detecting Criteria.>

CAUTION:

After repair or replacement of faulty parts, conduct Clear Memory Mode <Ref. to EN(H4SO)(diag)-44, OPERATION, Clear Memory Mode.> and Inspection Mode <Ref. to EN(H4SO)(diag)-37, OPERATION, Inspection Mode.>.

WIRING DIAGRAM:

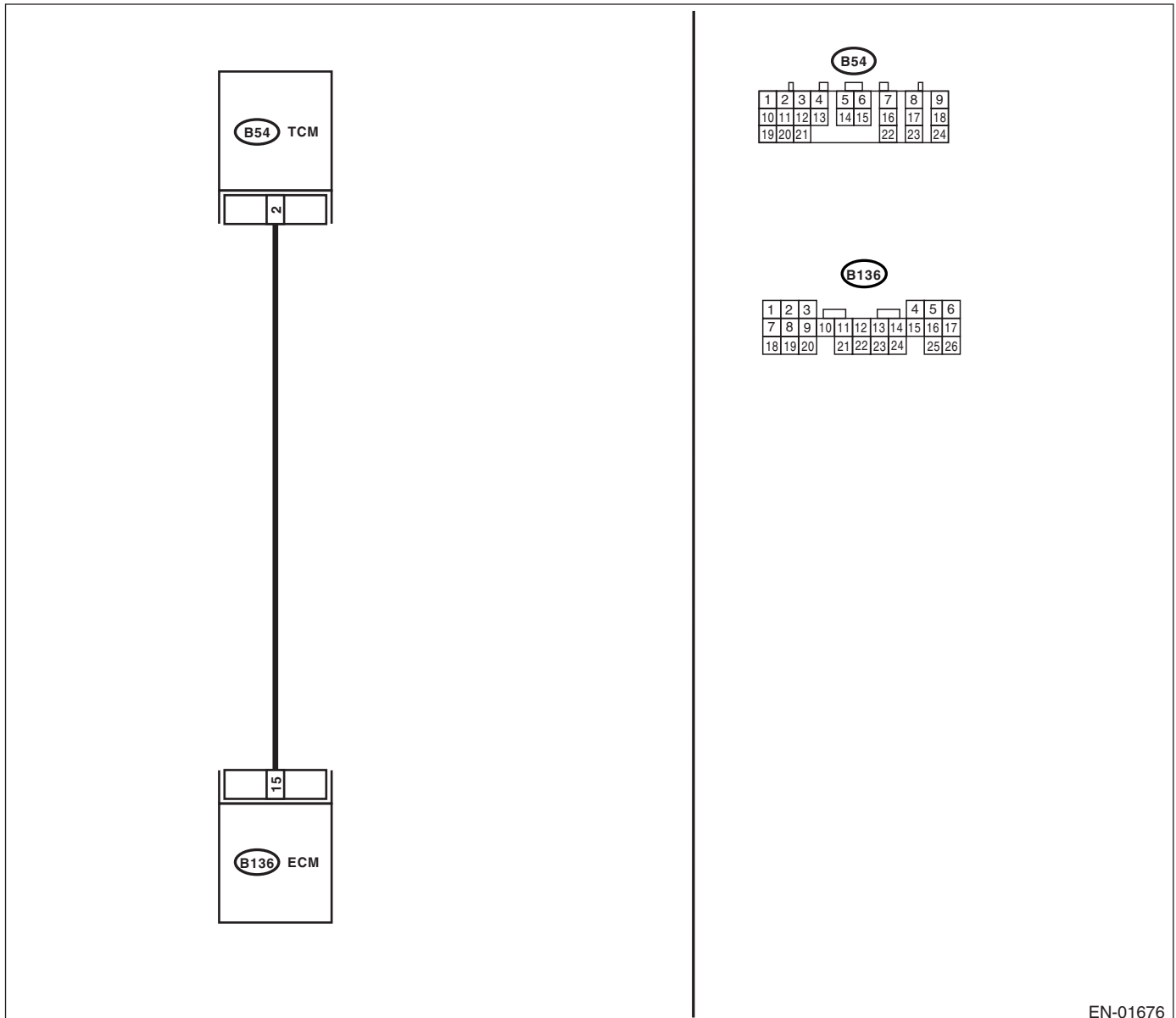

EN-01676

Diagnostic Procedure with Diagnostic Trouble Code (DTC)

ENGINE (DIAGNOSTICS)

Step	Check	Yes	No
<p>1 CHECK OUTPUT SIGNAL FROM ECM. 1) Start the engine, and warm-up the engine. 2) Turn the ignition switch to OFF. 3) Turn the ignition switch to ON. 4) Measure the voltage between ECM and chassis ground. Connector & terminal (B136) No. 15 (+) — Chassis ground (-):</p>	<p>Is the voltage more than 3 V?</p>	<p>Repair poor contact in ECM connector.</p>	<p>Go to step 2.</p>
<p>2 CHECK HARNESS BETWEEN ECM AND TCM CONNECTOR. 1) Turn the ignition switch to OFF. 2) Disconnect the connectors from ECM and TCM. 3) Measure the resistance of harness between ECM and chassis ground. Connector & terminal (B136) No. 15 — Chassis ground:</p>	<p>Is the resistance more than 1 MΩ?</p>	<p>Go to step 3.</p>	<p>Repair ground short circuit in harness between ECM and TCM connector.</p>
<p>3 CHECK HARNESS BETWEEN ECM AND TCM CONNECTOR. Measure the resistance of harness between ECM and TCM connector. Connector & terminal (B136) No. 15 — (B54) No. 2:</p>	<p>Is the resistance less than 1 Ω?</p>	<p>Repair poor contact in ECM or TCM connector.</p>	<p>Repair open circuit in harness between ECM and TCM connector.</p>

Diagnostic Procedure with Diagnostic Trouble Code (DTC)

ENGINE (DIAGNOSTICS)

DN:DTC P1699 ENGINE TORQUE CONTROL CUT SIGNAL CIRCUIT HIGH INPUT DTC DETECTING CONDITION:

- Two consecutive driving cycles with fault
- GENERAL DESCRIPTION <Ref. to GD(H4SO)-229, DTC P1699 ENGINE TORQUE CONTROL CUT SIGNAL CIRCUIT MALFUNCTION (HIGH INPUT), Diagnostic Trouble Code (DTC) Detecting Criteria.>

CAUTION:

After repair or replacement of faulty parts, conduct Clear Memory Mode <Ref. to EN(H4SO)(diag)-44, OPERATION, Clear Memory Mode.> and Inspection Mode <Ref. to EN(H4SO)(diag)-37, OPERATION, Inspection Mode.>.

WIRING DIAGRAM:

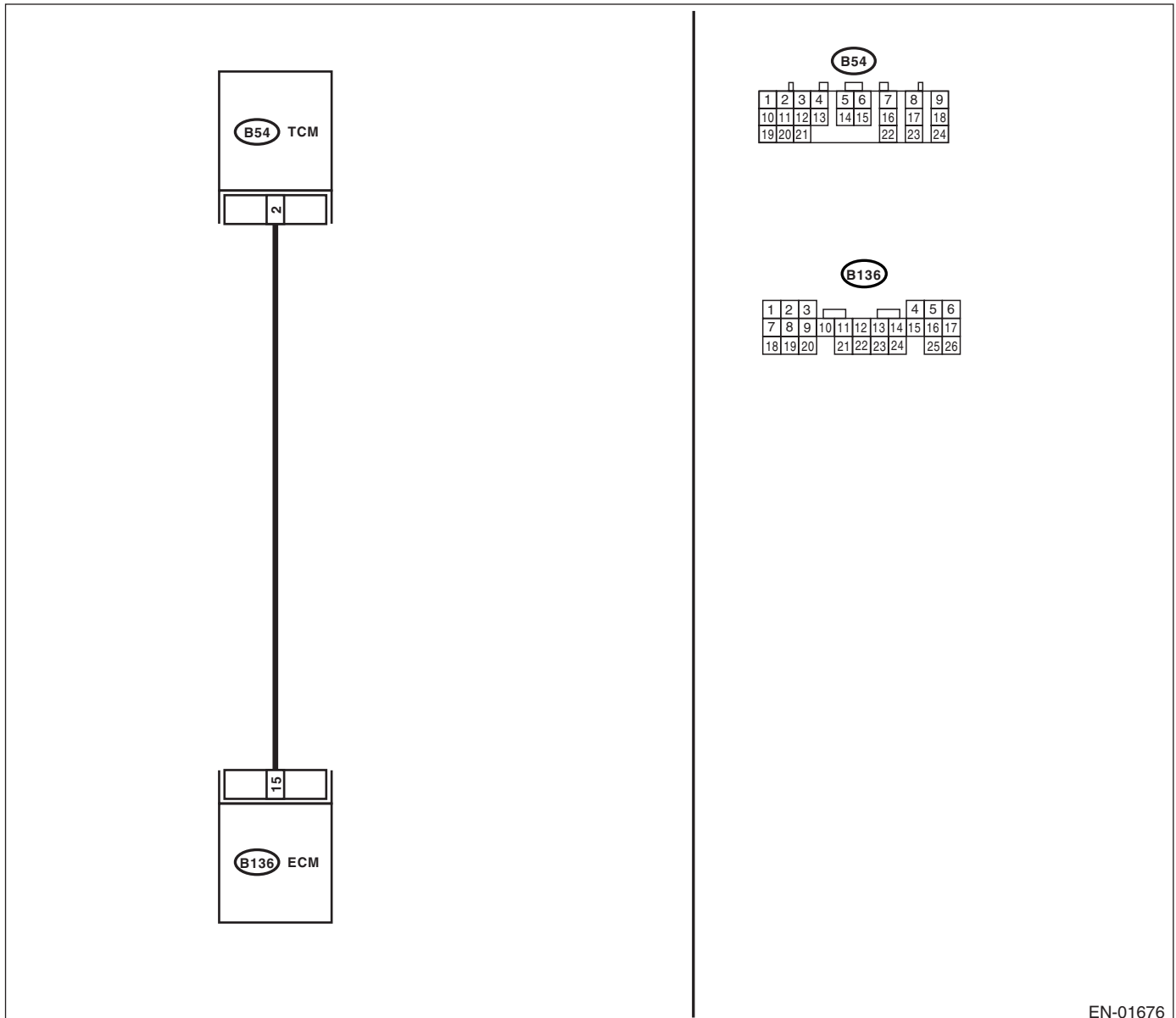

EN-01676

Diagnostic Procedure with Diagnostic Trouble Code (DTC)

ENGINE (DIAGNOSTICS)

Step	Check	Yes	No
1 CHECK OUTPUT SIGNAL FROM ECM. 1) Start the engine, and warm-up the engine. 2) Turn the ignition switch to OFF. 3) Disconnect the connector from TCM. 4) Turn the ignition switch to ON. 5) Measure the voltage between ECM and chassis ground. <i>Connector & terminal</i> <i>(B136) No. 15 (+) — Chassis ground (-):</i>	Is the voltage less than 3 V?	Go to step 2.	Repair battery short circuit in harness between ECM and TCM connector. After repair, replace the ECM. <Ref. to FU(H4SO)-44, Engine Control Module (ECM).>
2 CHECK HARNESS BETWEEN ECM AND TCM CONNECTOR. 1) Turn the ignition switch to OFF. 2) Measure the voltage between ECM and chassis ground. <i>Connector & terminal</i> <i>(B136) No. 15 (+) — Chassis ground (-):</i>	Is the voltage more than 10 V by shaking the harness and connector of ECM?	Repair battery short circuit in harness between ECM and TCM connector. After repair, replace the ECM. <Ref. to FU(H4SO)-44, Engine Control Module (ECM).>	Contact SOA Service Center. NOTE: Inspection by DTM is required, because probable cause is deterioration of multiple parts.

DO:DTC P1700 THROTTLE POSITION SENSOR CIRCUIT MALFUNCTION FOR AT

GENERAL DESCRIPTION <Ref. to GD(H4SO)-230, DTC P1700 THROTTLE POSITION SENSOR CIRCUIT MALFUNCTION FOR AT, Diagnostic Trouble Code (DTC) Detecting Criteria.>

NOTE:

Refer to AT-section for diagnostic procedure. <Ref. to 4AT(diag)-46, DTC 31 THROTTLE POSITION SENSOR, Diagnostic Procedure with Diagnostic Trouble Code (DTC).>

Diagnostic Procedure with Diagnostic Trouble Code (DTC)

ENGINE (DIAGNOSTICS)

DP:DTC P1711 ENGINE TORQUE CONTROL SIGNAL 1 CIRCUIT MALFUNCTION

DTC DETECTING CONDITION:

- Two consecutive driving cycles with fault
- GENERAL DESCRIPTION <Ref. to GD(H4SO)-232, DTC P1711 ENGINE TORQUE CONTROL SIGNAL #1 CIRCUIT MALFUNCTION, Diagnostic Trouble Code (DTC) Detecting Criteria.>

TROUBLE SYMPTOM:

Excessive shift shock

CAUTION:

After repair or replacement of faulty parts, conduct Clear Memory Mode <Ref. to EN(H4SO)(diag)-44, OPERATION, Clear Memory Mode.> and Inspection Mode <Ref. to EN(H4SO)(diag)-37, OPERATION, Inspection Mode.>.

WIRING DIAGRAM:

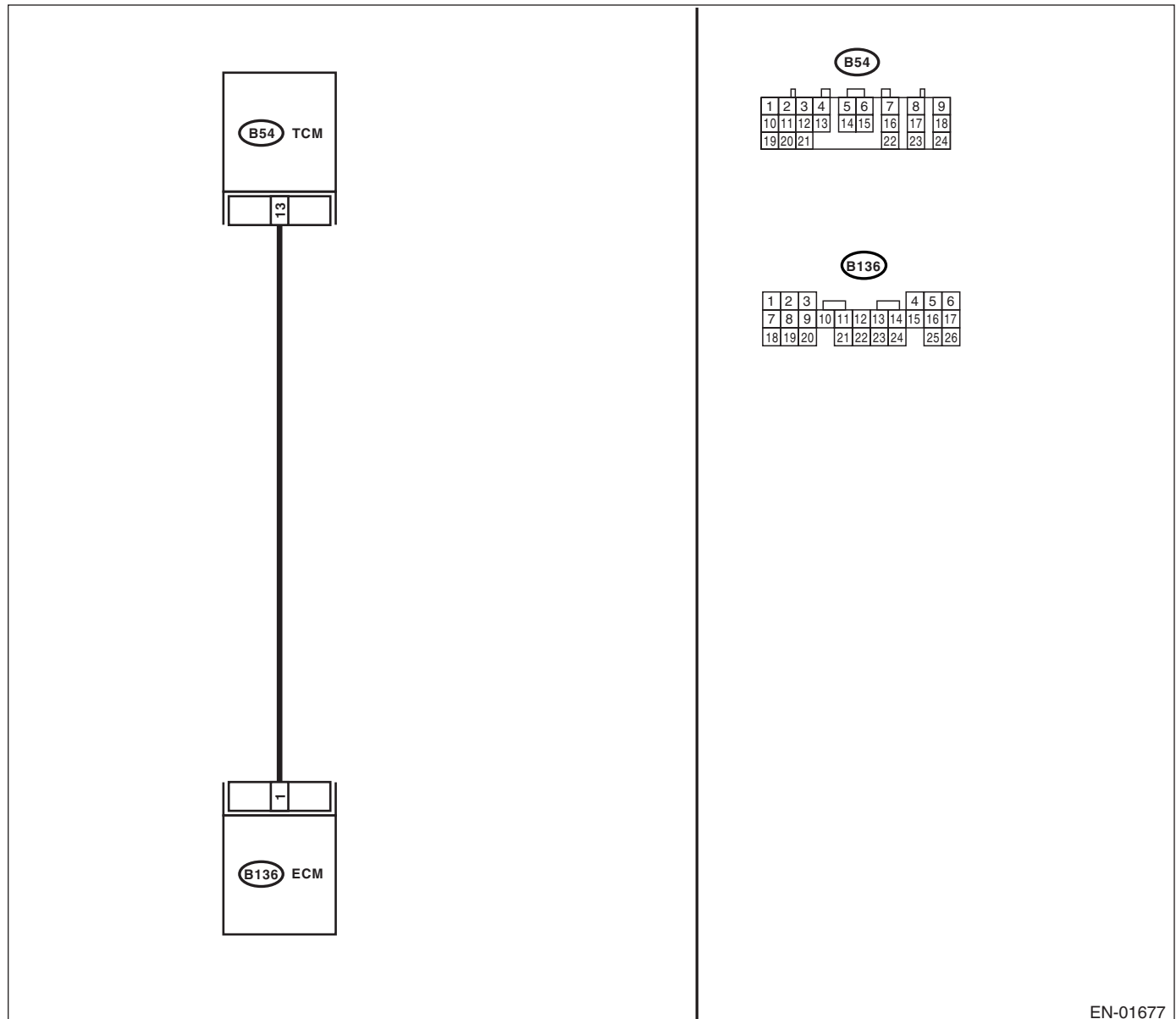

EN-01677

Diagnostic Procedure with Diagnostic Trouble Code (DTC)

ENGINE (DIAGNOSTICS)

Step	Check	Yes	No
1 CHECK INPUT SIGNAL FOR ECM. 1) Turn the ignition switch to ON. 2) Measure the voltage between ECM and chassis ground. Connector & terminal (B136) No. 1 (+) — Chassis ground (-):	Is the voltage more than 4.5 V?	Go to step 2.	Go to step 4.
2 CHECK INPUT SIGNAL FOR ECM. Measure the voltage between ECM and chassis ground. Connector & terminal (B136) No. 1 (+) — Chassis ground (-):	Is the voltage more than 10 V?	Repair battery short circuit in harness between ECM and TCM connector.	Go to step 3.
3 CHECK POOR CONTACT. Check poor contact in ECM connector.	Is there poor contact in ECM connector?	Repair poor contact in ECM connector.	Replace the ECM. <Ref. to FU(H4SO)-44, Engine Control Module (ECM).>
4 CHECK HARNESS BETWEEN ECM AND TCM CONNECTOR. 1) Turn the ignition switch to OFF. 2) Disconnect the connectors from ECM and TCM. 3) Measure the resistance of harness between ECM and TCM connector. Connector & terminal (B136) No. 1 — (B54) No. 13:	Is the resistance less than 1 Ω ?	Go to step 5.	Repair open circuit in harness between ECM and TCM connector.
5 CHECK HARNESS BETWEEN ECM AND TCM CONNECTOR. Measure the resistance of harness between ECM and chassis ground. Connector & terminal (B136) No. 1 — Chassis ground:	Is the resistance more than 1 M Ω ?	Go to step 6.	Repair ground short circuit in harness between ECM and TCM connector.
6 CHECK POOR CONTACT. Check poor contact in TCM connector.	Is there poor contact in TCM connector?	Repair poor contact in TCM connector.	Replace the TCM. <Ref. to 4AT-67, Transmission Control Module (TCM).>

Diagnostic Procedure with Diagnostic Trouble Code (DTC)

ENGINE (DIAGNOSTICS)

DQ:DTC P1712 ENGINE TORQUE CONTROL SIGNAL 2 CIRCUIT MALFUNCTION

DTC DETECTING CONDITION:

- Two consecutive driving cycles with fault
- GENERAL DESCRIPTION <Ref. to GD(H4SO)-233, DTC P1712 ENGINE TORQUE CONTROL SIGNAL #2 CIRCUIT MALFUNCTION, Diagnostic Trouble Code (DTC) Detecting Criteria.>

TROUBLE SYMPTOM:

Excessive shift shock

CAUTION:

After repair or replacement of faulty parts, conduct Clear Memory Mode <Ref. to EN(H4SO)(diag)-44, OPERATION, Clear Memory Mode.> and Inspection Mode <Ref. to EN(H4SO)(diag)-37, OPERATION, Inspection Mode.>.

WIRING DIAGRAM:

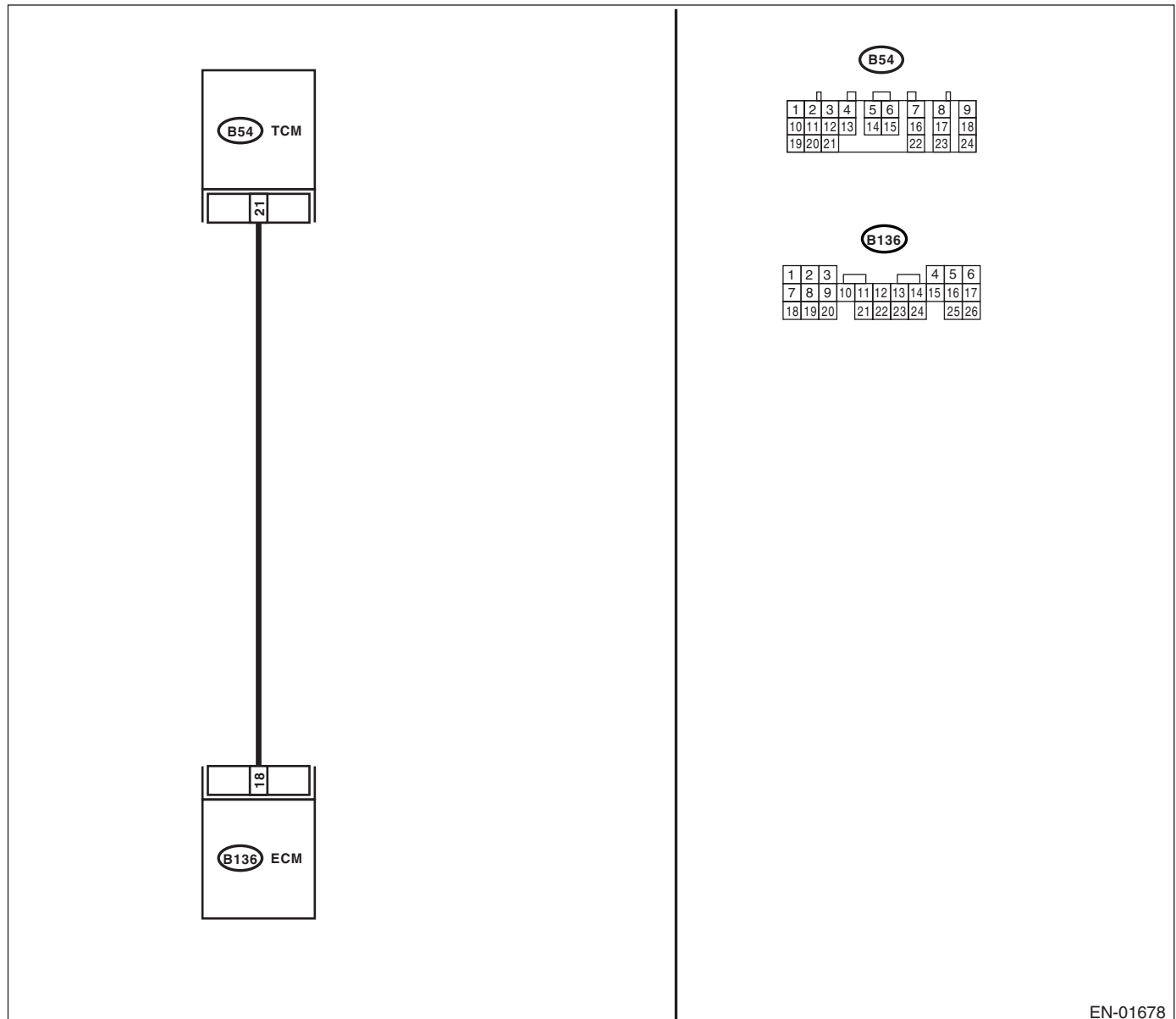

EN-01678

Diagnostic Procedure with Diagnostic Trouble Code (DTC)

ENGINE (DIAGNOSTICS)

Step	Check	Yes	No
1 CHECK INPUT SIGNAL FOR ECM. 1) Turn the ignition switch to ON. 2) Measure the voltage between ECM and chassis ground. Connector & terminal (B136) No. 18 (+) — Chassis ground (-):	Is the voltage more than 4.5 V?	Go to step 2.	Go to step 4.
2 CHECK INPUT SIGNAL FOR ECM. Measure the voltage between ECM and chassis ground. Connector & terminal (B136) No. 18 (+) — Chassis ground (-):	Is the voltage more than 10 V?	Repair battery short circuit in harness between ECM and TCM connector.	Go to step 3.
3 CHECK POOR CONTACT. Check poor contact in ECM connector.	Is there poor contact in ECM connector?	Repair poor contact in ECM connector.	Replace the ECM. <Ref. to FU(H4SO)-44, Engine Control Module (ECM).>
4 CHECK HARNESS BETWEEN ECM AND TCM CONNECTOR. 1) Turn the ignition switch to OFF. 2) Disconnect the connectors from ECM and TCM. 3) Measure the resistance of harness between ECM and TCM connector. Connector & terminal (B136) No. 18 — (B54) No. 21:	Is the resistance less than 1 Ω ?	Go to step 5.	Repair open circuit in harness between ECM and TCM connector.
5 CHECK HARNESS BETWEEN ECM AND TCM CONNECTOR. Measure the resistance of harness between ECM and chassis ground. Connector & terminal (B136) No. 18 — Chassis ground:	Is the resistance more than 1 M Ω ?	Go to step 6.	Repair ground short circuit in harness between ECM and TCM connector.
6 CHECK POOR CONTACT. Check poor contact in TCM connector.	Is there poor contact in TCM connector?	Repair poor contact in TCM connector.	Replace the TCM. <Ref. to 4AT-67, Transmission Control Module (TCM).>

Diagnostic Procedure with Diagnostic Trouble Code (DTC)

ENGINE (DIAGNOSTICS)

DR:DTC P2096 POST CATALYST FUEL TRIM SYSTEM TOO LEAN BANK 1

DTC DETECTING CONDITION:

- Two consecutive driving cycles with fault
- GENERAL DESCRIPTION <Ref. to GD(H4SO)-234, DTC P2096 POST CATALYST FUEL TRIM SYSTEM TOO LEAN BANK 1, Diagnostic Trouble Code (DTC) Detecting Criteria.>

CAUTION:

After repair or replacement of faulty parts, conduct Clear Memory Mode <Ref. to EN(H4SO)(diag)-44, OPERATION, Clear Memory Mode.> and Inspection Mode <Ref. to EN(H4SO)(diag)-37, OPERATION, Inspection Mode.>.

WIRING DIAGRAM:

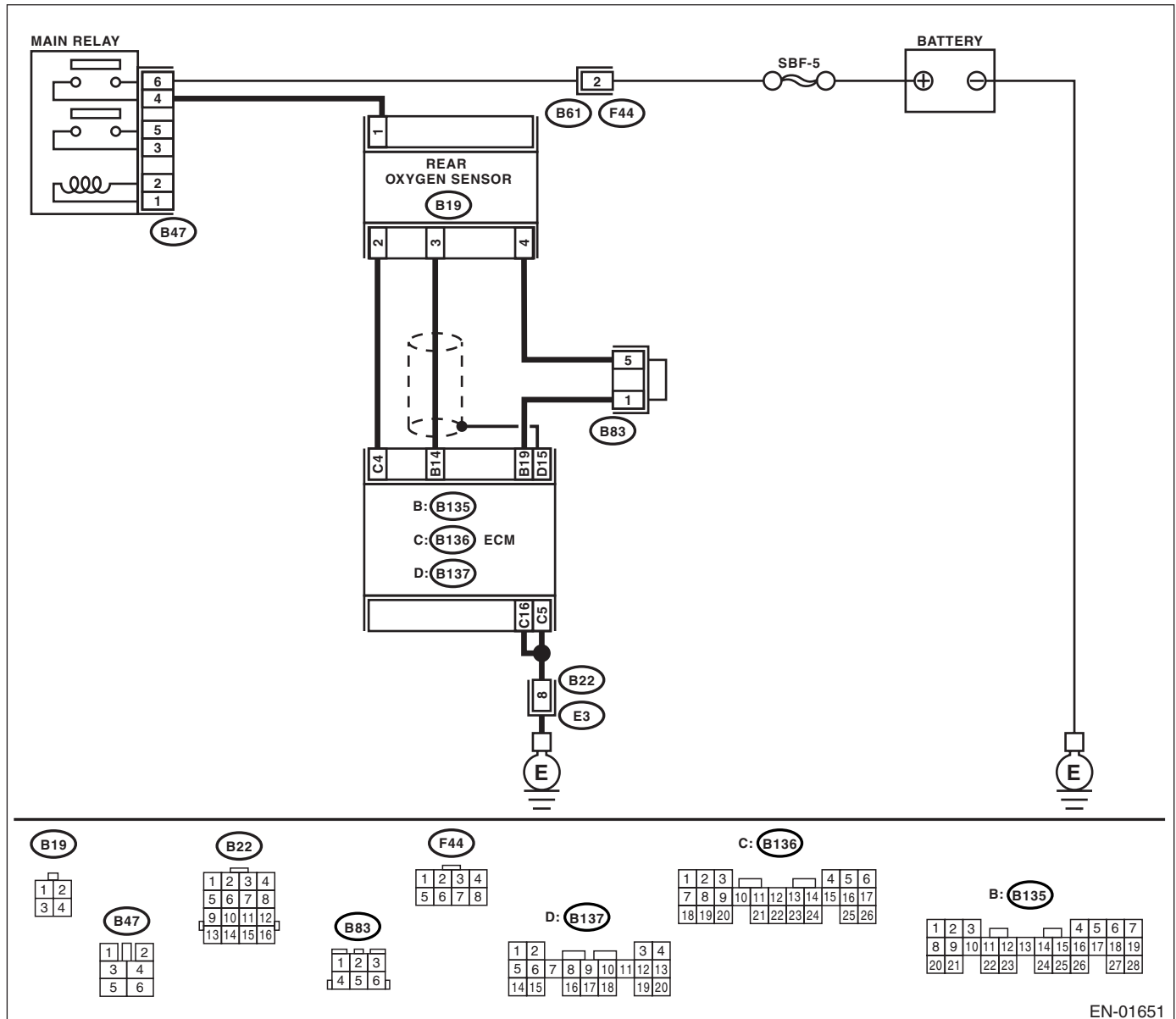

EN-01651

Diagnostic Procedure with Diagnostic Trouble Code (DTC)

ENGINE (DIAGNOSTICS)

Step	Check	Yes	No
1 CHECK ANY OTHER DTC ON DISPLAY.	Is any other DTC displayed?	Check DTC using "List of Diagnostic Trouble Code (DTC)". <Ref. to EN(H4SO)(diag)-71, List of Diagnostic Trouble Code (DTC).> NOTE: In this case, it is not necessary to inspect DTC P0137.	Go to step 2.
2 CHECK REAR OXYGEN SENSOR DATA. 1) Warm-up the engine until engine coolant temperature is above 70°C (158°F), and keep the engine speed at 5,000 rpm. 2) Read the data of rear oxygen sensor signal using Subaru Select Monitor or OBD-II general scan tool. NOTE: • Subaru Select Monitor For detailed operation procedure, refer to the "READ CURRENT DATA SHOWN ON DISPLAY FOR ENGINE". <Ref. to EN(H4SO)(diag)-30, Subaru Select Monitor.> • OBD-II general scan tool For detailed operation procedures, refer to the OBD-II General Scan Tool Instruction Manual.	Is the voltage 490 mV?	Go to step 5.	Go to step 3.
3 CHECK HARNESS BETWEEN ECM AND REAR OXYGEN SENSOR CONNECTOR. 1) Turn the ignition switch to OFF. 2) Disconnect the connectors from ECM and rear oxygen sensor. 3) Measure the resistance of harness between ECM and rear oxygen sensor connector. Connector & terminal (B135) No. 14 — (B19) No. 3: (B135) No. 19 — (B19) No. 4:	Is the resistance more than 3 Ω?	Repair open circuit in harness between ECM and rear oxygen sensor connector.	Go to step 4.
4 CHECK HARNESS BETWEEN REAR OXYGEN SENSOR AND ECM CONNECTOR. 1) Turn the ignition switch to OFF. 2) Disconnect the connector from rear oxygen sensor. 3) Turn the ignition switch to ON. 4) Measure the voltage between rear oxygen sensor harness connector and engine ground or chassis ground. Connector & terminal (B19) No. 3 (+) — Engine ground (-):	Is the voltage 0.2 — 0.5 V?	Replace the rear oxygen sensor. <Ref. to FU(H4SO)-42, Rear Oxygen Sensor.>	Repair harness and connector. NOTE: In this case, repair the following: • Open circuit in harness between rear oxygen sensor and ECM connector • Poor contact in rear oxygen sensor connector • Poor contact in ECM connector

Diagnostic Procedure with Diagnostic Trouble Code (DTC)

ENGINE (DIAGNOSTICS)

Step	Check	Yes	No
5 CHECK EXHAUST SYSTEM. Check exhaust system parts. NOTE: Check the following items. <ul style="list-style-type: none"> • Loose installation of portions • Damage (crack, hole etc.) of parts • Looseness and ill fitting of parts between front oxygen (A/F) sensor and rear oxygen sensor 	Is there a fault in exhaust system?	Repair or replace faulty parts.	Go to step 6.
6 CHECK AIR INTAKE SYSTEM.	Are there holes, loose bolts or disconnection of hose on air intake system?	Repair air intake system.	Go to step 7.
7 CHECK PURGE CONTROL SOLENOID VALVE OR PRESSURE CONTROL SOLENOID VALVE.	Is the purge control solenoid valve or pressure control solenoid valve stuck?	Replace the purge control solenoid valve or pressure control solenoid valve.	Go to step 8.
8 CHECK FUEL PRESSURE. Warning: <ul style="list-style-type: none"> • Place “NO FIRE” signs near the working area. • Be careful not to spill fuel on the floor. 1) Release fuel pressure. (1) Disconnect the connector from fuel pump relay. (2) Start the engine and run it until it stalls. (3) After the engine stalls, crank it for five more seconds. (4) Turn the ignition switch to OFF. 2) Connect the connector to fuel pump relay. 3) Disconnect the fuel delivery hose from fuel filter, and connect fuel pressure gauge. 4) Install the fuel filler cap. 5) Start the engine and idle while gear position is neutral. 6) Measure the fuel pressure while disconnecting pressure regulator vacuum hose from intake manifold. Warning: Before removing the fuel pressure gauge, release fuel pressure. NOTE: If fuel pressure does not increase, squeeze fuel return hose 2 to 3 times, then measure fuel pressure again.	Is the fuel pressure 284 — 314 kPa (2.9 — 3.2 kg/cm ² , 41 — 46 psi)?	Go to step 9.	Repair the following items. Fuel pressure too high <ul style="list-style-type: none"> • Clogged fuel return line or bent hose Fuel pressure too low <ul style="list-style-type: none"> • Improper fuel pump discharge • Clogged fuel supply line

Diagnostic Procedure with Diagnostic Trouble Code (DTC)

ENGINE (DIAGNOSTICS)

	Step	Check	Yes	No
<p>9</p> <p>CHECK FUEL PRESSURE. After connecting the pressure regulator vacuum hose, measure fuel pressure.</p> <p>Warning: Before removing the fuel pressure gauge, release fuel pressure.</p> <p>NOTE:</p> <ul style="list-style-type: none"> If fuel pressure does not increase, squeeze fuel return hose 2 to 3 times, then measure fuel pressure again. If out of specification as measured at this step, check or replace pressure regulator and pressure regulator vacuum hose. 	<p>Is the fuel pressure 206 — 235 kPa (2.1 — 2.4 kg/cm², 30 — 34 psi)?</p>	<p>Go to step 10.</p>	<p>Repair the following items.</p> <p>Fuel pressure too high</p> <ul style="list-style-type: none"> Faulty pressure regulator Clogged fuel return line or bent hose <p>Fuel pressure too low</p> <ul style="list-style-type: none"> Faulty pressure regulator Improper fuel pump discharge Clogged fuel supply line 	
<p>10</p> <p>CHECK ENGINE COOLANT TEMPERATURE SENSOR.</p> <ol style="list-style-type: none"> Start the engine and warm-up completely. Read the data of engine coolant temperature sensor signal using Subaru Select Monitor or OBD-II general scan tool. <p>NOTE:</p> <ul style="list-style-type: none"> Subaru Select Monitor <p>For detailed operation procedure, refer to the “READ CURRENT DATA FOR ENGINE”. <Ref. to EN(H4SO)(diag)-30, Subaru Select Monitor.></p> <ul style="list-style-type: none"> OBD-II general scan tool <p>For detailed operation procedures, refer to the OBD-II General Scan Tool Instruction Manual.</p>	<p>Is the engine coolant temperature 70 — 100°C (158 — 212°F)?</p>	<p>Go to step 11.</p>	<p>Replace the engine coolant temperature sensor. <Ref. to FU(H4SO)-24, Engine Coolant Temperature Sensor.></p>	
<p>11</p> <p>CHECK PRESSURE SENSOR SIGNAL.</p> <ol style="list-style-type: none"> Start the engine and warm-up engine until coolant temperature is greater than 60°C (140°F). Place the select lever in “N” or “P” range. Turn the A/C switch to OFF. Turn all accessory switches to OFF. Read the data of pressure sensor signal using Subaru Select Monitor or OBD-II general scan tool. <p>NOTE:</p> <ul style="list-style-type: none"> Subaru Select Monitor <p>For detailed operation procedure, refer to the “READ CURRENT DATA FOR ENGINE”. <Ref. to EN(H4SO)(diag)-30, Subaru Select Monitor.></p> <ul style="list-style-type: none"> OBD-II general scan tool <p>For detailed operation procedures, refer to the OBD-II General Scan Tool Instruction Manual.</p>	<p>Idling: Is the measured value 24.0 — 41.3 kPa (180 — 310 mmHg, 7.09 — 12.20 inHg), Ignition ON: Is the measured value 73.3 — 106.6 kPa (550 — 800 mmHg, 21.65 — 31.50 inHg)?</p>	<p>Contact SOA Service Center.</p> <p>NOTE: Inspection by DTM is required, because probable cause is deterioration of multiple parts.</p>	<p>Replace the Pressure sensor. <Ref. to FU(H4SO)-30, Manifold Absolute Pressure Sensor.></p>	

Diagnostic Procedure with Diagnostic Trouble Code (DTC)

ENGINE (DIAGNOSTICS)

DS:DTC P2097 POST CATALYST FUEL TRIM SYSTEM TOO RICH BANK 1

DTC DETECTING CONDITION:

- Two consecutive driving cycles with fault
- GENERAL DESCRIPTION <Ref. to GD(H4SO)-236, DTC P2097 POST CATALYST FUEL TRIM SYSTEM TOO RICH BANK 1, Diagnostic Trouble Code (DTC) Detecting Criteria.>

CAUTION:

After repair or replacement of faulty parts, conduct Clear Memory Mode <Ref. to EN(H4SO)(diag)-44, OPERATION, Clear Memory Mode.> and Inspection Mode <Ref. to EN(H4SO)(diag)-37, OPERATION, Inspection Mode.>.

WIRING DIAGRAM:

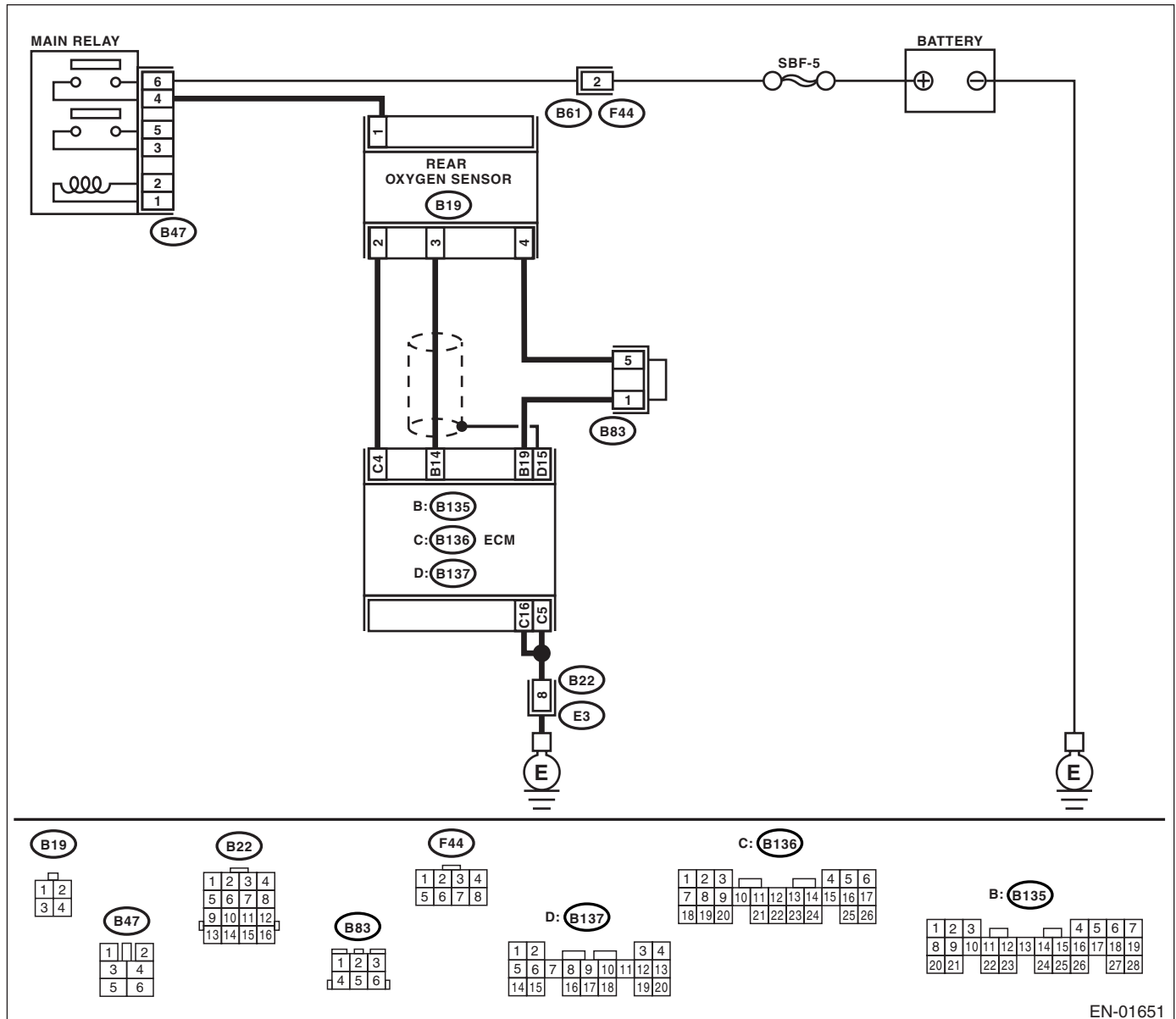

EN-01651

Diagnostic Procedure with Diagnostic Trouble Code (DTC)

ENGINE (DIAGNOSTICS)

Step	Check	Yes	No
1 CHECK ANY OTHER DTC ON DISPLAY.	Is any other DTC displayed?	Check DTC using "List of Diagnostic Trouble Code (DTC)". <Ref. to EN(H4SO)(diag)-71, List of Diagnostic Trouble Code (DTC).> NOTE: In this case, it is not necessary to inspect DTC P0138.	Go to step 2.
2 CHECK REAR OXYGEN SENSOR DATA. 1) Warm-up the engine until engine coolant temperature is above 70°C (158°F), and immediately decrease the engine speed from 5,000 rpm. 2) Read the data of rear oxygen sensor signal using Subaru Select Monitor or OBD-II general scan tool. NOTE: • Subaru Select Monitor For detailed operation procedure, refer to the "READ CURRENT DATA SHOWN ON DISPLAY FOR ENGINE". <Ref. to EN(H4SO)(diag)-30, Subaru Select Monitor.> • OBD-II general scan tool For detailed operation procedures, refer to the OBD-II General Scan Tool Instruction Manual.	Is the voltage 250 mV?	Go to step 5.	Go to step 3.
3 CHECK HARNESS BETWEEN ECM AND REAR OXYGEN SENSOR CONNECTOR. 1) Turn the ignition switch to OFF. 2) Disconnect the connectors from ECM and rear oxygen sensor. 3) Measure the resistance of harness between ECM and rear oxygen sensor connector. Connector & terminal (B135) No. 14 — (B19) No. 3: (B135) No. 19 — (B19) No. 4:	Is the resistance more than 3 Ω?	Repair open circuit in harness between ECM and rear oxygen sensor connector.	Go to step 4.
4 CHECK HARNESS BETWEEN REAR OXYGEN SENSOR AND ECM CONNECTOR. 1) Turn the ignition switch to OFF. 2) Disconnect the connector from rear oxygen sensor. 3) Turn the ignition switch to ON. 4) Measure the voltage between rear oxygen sensor harness connector and engine ground or chassis ground. Connector & terminal (B19) No. 3 (+) — Engine ground (-):	Is the voltage 0.2 — 0.5 V?	Replace the rear oxygen sensor. <Ref. to FU(H4SO)-42, Rear Oxygen Sensor.>	Repair harness and connector. NOTE: In this case, repair the following: • Open circuit in harness between rear oxygen sensor and ECM connector • Poor contact in rear oxygen sensor connector • Poor contact in ECM connector

Diagnostic Procedure with Diagnostic Trouble Code (DTC)

ENGINE (DIAGNOSTICS)

Step	Check	Yes	No
5 CHECK EXHAUST SYSTEM. Check exhaust system parts. NOTE: Check the following items. <ul style="list-style-type: none"> • Loose installation of portions • Damage (crack, hole etc.) of parts • Looseness and ill fitting of parts between front oxygen (A/F) sensor and rear oxygen sensor 	Is there a fault in exhaust system?	Repair or replace faulty parts.	Go to step 6.
6 CHECK AIR INTAKE SYSTEM.	Are there holes, loose bolts or disconnection of hose on air intake system?	Repair air intake system.	Go to step 7.
7 CHECK PURGE CONTROL SOLENOID VALVE OR PRESSURE CONTROL SOLENOID VALVE.	Is the purge control solenoid valve or pressure control solenoid valve stuck?	Replace the purge control solenoid valve or pressure control solenoid valve.	Go to step 8.
8 CHECK FUEL PRESSURE. Warning: <ul style="list-style-type: none"> • Place “NO FIRE” signs near the working area. • Be careful not to spill fuel on the floor. 1) Release fuel pressure. (1) Disconnect the connector from fuel pump relay. (2) Start the engine and run it until it stalls. (3) After the engine stalls, crank it for five more seconds. (4) Turn the ignition switch to OFF. 2) Connect the connector to fuel pump relay. 3) Disconnect the fuel delivery hose from fuel filter, and connect fuel pressure gauge. 4) Install the fuel filler cap. 5) Start the engine and idle while gear position is neutral. 6) Measure the fuel pressure while disconnecting pressure regulator vacuum hose from intake manifold. Warning: Before removing the fuel pressure gauge, release fuel pressure. NOTE: If fuel pressure does not increase, squeeze fuel return hose 2 to 3 times, then measure fuel pressure again.	Is the fuel pressure 284 — 314 kPa (2.9 — 3.2 kg/cm ² , 41 — 46 psi)?	Go to step 9.	Repair the following items. Fuel pressure too high <ul style="list-style-type: none"> • Clogged fuel return line or bent hose Fuel pressure too low <ul style="list-style-type: none"> • Improper fuel pump discharge • Clogged fuel supply line

Diagnostic Procedure with Diagnostic Trouble Code (DTC)

ENGINE (DIAGNOSTICS)

	Step	Check	Yes	No
<p>9</p> <p>CHECK FUEL PRESSURE. After connecting the pressure regulator vacuum hose, measure fuel pressure.</p> <p>Warning: Before removing the fuel pressure gauge, release fuel pressure.</p> <p>NOTE: <ul style="list-style-type: none"> If fuel pressure does not increase, squeeze fuel return hose 2 to 3 times, then measure fuel pressure again. If out of specification as measured at this step, check or replace pressure regulator and pressure regulator vacuum hose. </p>	<p>Is the fuel pressure 206 — 235 kPa (2.1 — 2.4 kg/cm², 30 — 34 psi)?</p>	<p>Go to step 10.</p>	<p>Repair the following items.</p> <p>Fuel pressure too high</p> <ul style="list-style-type: none"> Faulty pressure regulator Clogged fuel return line or bent hose <p>Fuel pressure too low</p> <ul style="list-style-type: none"> Faulty pressure regulator Improper fuel pump discharge Clogged fuel supply line 	
<p>10</p> <p>CHECK ENGINE COOLANT TEMPERATURE SENSOR. 1) Start the engine and warm-up completely. 2) Read the data of engine coolant temperature sensor signal using Subaru Select Monitor or OBD-II general scan tool.</p> <p>NOTE: <ul style="list-style-type: none"> Subaru Select Monitor For detailed operation procedure, refer to the "READ CURRENT DATA FOR ENGINE". <Ref. to EN(H4SO)(diag)-30, Subaru Select Monitor.> <ul style="list-style-type: none"> OBD-II general scan tool For detailed operation procedures, refer to the OBD-II General Scan Tool Instruction Manual.</p>	<p>Is the engine coolant temperature 70 — 100°C (158 — 212°F)?</p>	<p>Go to step 11.</p>	<p>Replace the engine coolant temperature sensor. <Ref. to FU(H4SO)-24, Engine Coolant Temperature Sensor.></p>	
<p>11</p> <p>CHECK PRESSURE SENSOR SIGNAL. 1) Start the engine and warm-up engine until coolant temperature is greater than 60°C (140°F). 2) Place the select lever in "N" or "P" range. 3) Turn the A/C switch to OFF. 4) Turn all accessory switches to OFF. 5) Read the data of pressure sensor signal using Subaru Select Monitor or OBD-II general scan tool.</p> <p>NOTE: <ul style="list-style-type: none"> Subaru Select Monitor For detailed operation procedure, refer to the "READ CURRENT DATA FOR ENGINE". <Ref. to EN(H4SO)(diag)-30, Subaru Select Monitor.> <ul style="list-style-type: none"> OBD-II general scan tool For detailed operation procedures, refer to the OBD-II General Scan Tool Instruction Manual.</p>	<p>Idling: Is the measured value 24.0 — 41.3 kPa (180 — 310 mmHg, 7.09 — 12.20 inHg), Ignition ON: Is the measured value 73.3 — 106.6 kPa (550 — 800 mmHg, 21.65 — 31.50 inHg)?</p>	<p>Contact SOA Service Center.</p> <p>NOTE: Inspection by DTM is required, because probable cause is deterioration of multiple parts.</p>	<p>Replace the Pressure sensor. <Ref. to FU(H4SO)-30, Manifold Absolute Pressure Sensor.></p>	