

Brought to you by Eris Studios  
NOT FOR RESALE

# INTAKE (INDUCTION)

# General Description

INTAKE (INDUCTION)

## 1. General Description

### A: COMPONENT

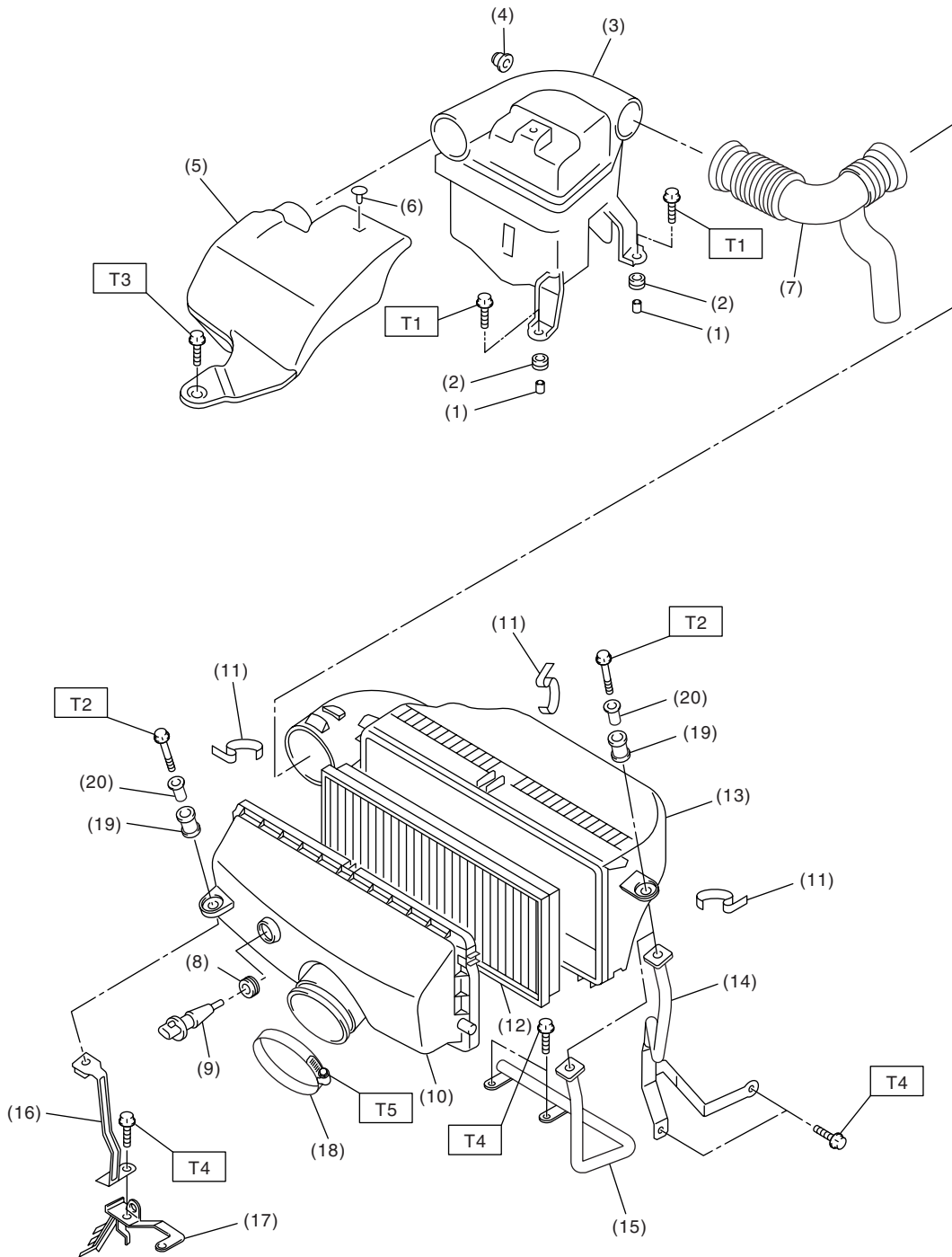

IN-00188

IN(H4SO)-2

## General Description

INTAKE (INDUCTION)

- |                                   |                             |
|-----------------------------------|-----------------------------|
| (1) Spacer                        | (10) Air cleaner case A     |
| (2) Bush                          | (11) Clip                   |
| (3) Resonator chamber             | (12) Air cleaner element    |
| (4) Cushion                       | (13) Air cleaner case B     |
| (5) Air intake duct A             | (14) Stay LH (MT model)     |
| (6) Clip                          | (15) Stay LH (AT model)     |
| (7) Air intake duct B             | (16) Stay RH                |
| (8) Bush                          | (17) Engine harness bracket |
| (9) Intake air temperature sensor | (18) Clamp                  |

- |             |
|-------------|
| (19) Bush   |
| (20) Spacer |

---

**Tightening torque: N·m (kgf·m, ft·lb)**

**T1: 33 (3.4, 24.6)**

**T2: 6.5 (0.66, 4.8)**

**T3: 7.5 (0.76, 5.5)**

**T4: 16 (1.6, 11.6)**

**T5: 3 (0.3, 2.2)**

---

### B: CAUTION

- Wear working clothing, including a cap, protective goggles, and protective shoes during operation.
- Remove contamination including dirt and corrosion before removal, installation or disassembly.
- Keep the disassembled parts in order and protect them from dust or dirt.
- Before removal, installation or disassembly, be sure to clarify the failure. Avoid unnecessary removal, installation, disassembly, and replacement.
- Be careful not to burn your hands, because each part on the vehicle is hot after running.
- Be sure to tighten fasteners including bolts and nuts to the specified torque.
- Place shop jacks or safety stands at the specified points.
- Before disconnecting electrical connectors of sensor or units, be sure to disconnect the ground cable from battery.

## 2. Air Cleaner Element

### A: REMOVAL

- 1) Remove the air intake duct from air cleaner case.
- 2) Remove the bolt (A) which secures the air cleaner case to stay.
- 3) Remove the clip (B) above the air cleaner case.

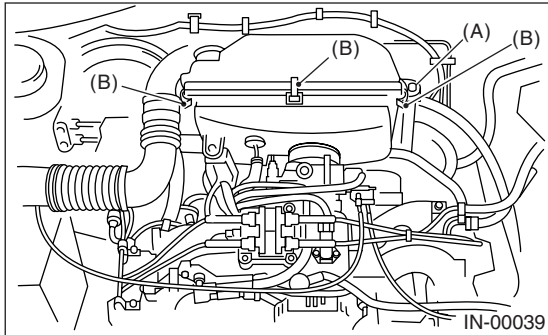

- 4) Remove the air cleaner element.

### B: INSTALLATION

Install in the reverse order of removal.

#### NOTE:

- Fasten with a clip after inserting the lower tab of case.
- Refer to "COMPONENT" for tightening torque.  
<Ref. to IN(H4SO)-2, COMPONENT, General Description.>

### C: INSPECTION

Replace if excessively damaged or dirty.

### 3. Air Cleaner Case

#### A: REMOVAL

1) Disconnect the ground cable from battery.

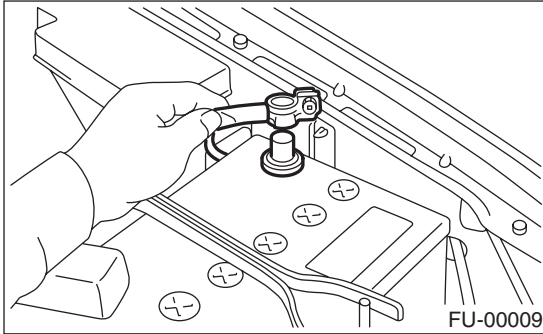

2) Disconnect the connector (A) of intake air temperature sensor.

3) Remove the bolt (B) which installs the air cleaner case to the stay.

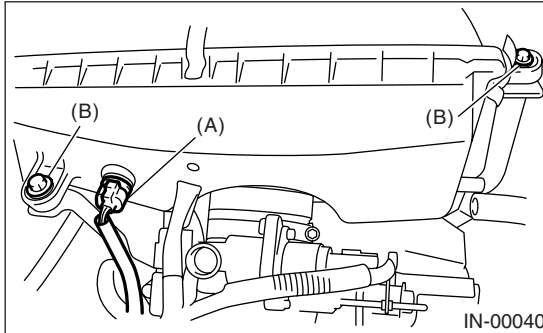

4) Disconnect the hoses and intake duct from the air cleaner case.

5) Loosen the clamp which connects the air cleaner case to throttle body.

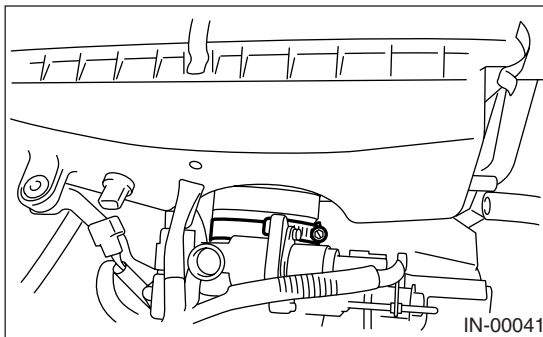

6) Remove the air cleaner case.

#### B: INSTALLATION

Install in the reverse order of removal.

#### NOTE:

Refer to "COMPONENT" for tightening torque.  
<Ref. to IN(H4SO)-2, COMPONENT, General Description.>

#### C: INSPECTION

Inspect for cracks and loose connections.

### 4. Air Intake Duct

#### A: REMOVAL

- 1) Remove the bolt (A) which installs the air intake duct A on front side of body.
- 2) Remove the clip (B) which connects the air intake duct A to resonator chamber.
- 3) Remove the air intake duct A.
- 4) Remove the air intake duct B from the resonator chamber and air cleaner case.

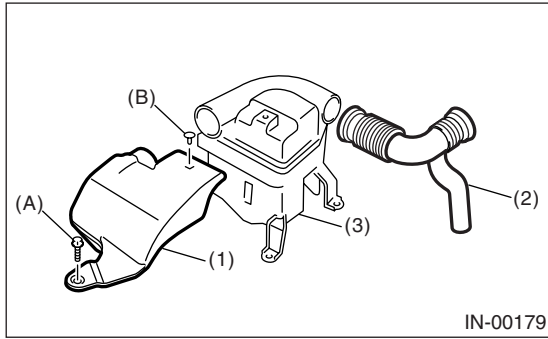

- (1) Air intake duct A
- (2) Air intake duct B
- (3) Resonator chamber

#### B: INSTALLATION

Install in the reverse order of removal.

#### NOTE:

Refer to "COMPONENT" for tightening torque.  
<Ref. to IN(H4SO)-2, COMPONENT, General Description.>

#### C: INSPECTION

- 1) Inspect for cracks and loose connections.
- 2) Inspect that no foreign objects are mixed in the air intake duct.

## 5. Resonator Chamber

### A: REMOVAL

- 1) Remove the air intake duct. <Ref. to IN(H4SO)-6, REMOVAL, Air Intake Duct.>
- 2) Remove the resonator chamber.

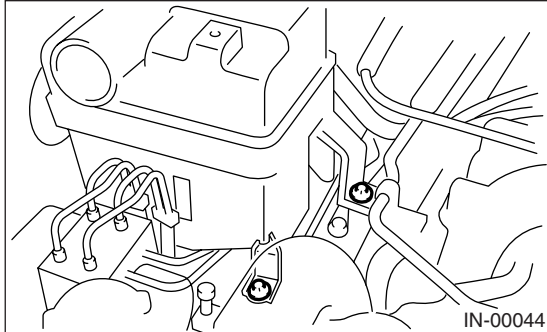

### B: INSTALLATION

Install in the reverse order of removal.

#### NOTE:

Refer to "COMPONENT" for tightening torque.  
<Ref. to IN(H4SO)-2, COMPONENT, General Description.>

### C: INSPECTION

Inspect for cracks and loose connections.

INTAKE (INDUCTION)

---

## Resonator Chamber

Brought to you by Eris Studios  
NOT FOR RESALE

IN(H4SO)-8