

Brought to you by Eris Studios  
NOT FOR RESALE

# **GLASS/WINDOWS/MIRRORS**

## POWER WINDOW

GLASS/WINDOWS/MIRRORS

### 1. Power Window

#### A: CONSTRUCTION

- The power window system consists of regulator motors and switches for individual doors, relays and a circuit breaker unit.
- Each door window opens/closes by pushing down/pulling up the switch.
- Only the driver's door window switch has a 2-stage mechanism:
  - When the switch is pushed lightly and held in the pushed position, the window continues to lower until the switch is released.
  - When the switch is pushed down fully, the window lowers to the end position automatically.

#### NOTE:

For the sake of safety, the power window system is designed to operate only when the ignition switch is in the ON position.

GW-2

# POWER WINDOW

GLASS/WINDOWS/MIRRORS

## B: SCHEMATIC DRAWINGS

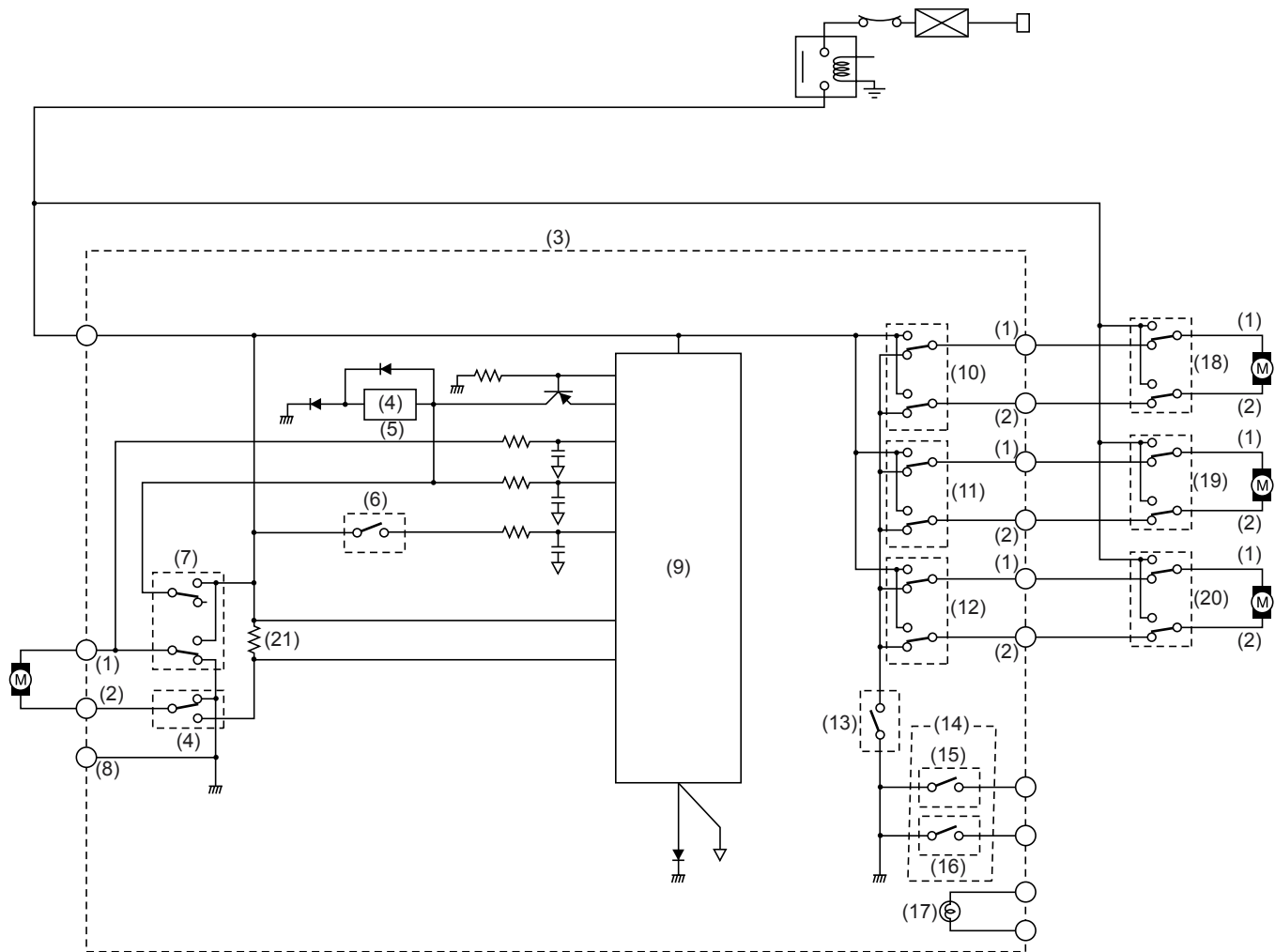

GW-00247

- |                               |                                    |
|-------------------------------|------------------------------------|
| (1) Raise                     | (12) Rear right                    |
| (2) Lower                     | (13) Power window lock             |
| (3) Power window main switch  | (14) Door lock                     |
| (4) Lowering relay            | (15) Unlock                        |
| (5) Relay 1                   | (16) Lock                          |
| (6) Automatic lowering switch | (17) Lamp 1                        |
| (7) Switch 1                  | (18) Passenger's switch            |
| (8) Ground                    | (19) Rear left passenger's switch  |
| (9) Automatic circuit         | (20) Rear right passenger's switch |
| (10) Passenger                | (21) Current detection resistor    |
| (11) Rear left                |                                    |

GW-3

## DOOR MIRRORS

GLASS/WINDOWS/MIRRORS

### 2. Door Mirrors

#### A: GENERAL

The shape of the door mirrors is modified and the door mirrors are now provided with a scalp cap. When driving in rain, droplets that have fallen on the door mirrors are drained through the groove in the door mirrors, thus preventing droplets from being splashed on the mirror glass by wind turbulence.

The scalp cap can be replaced individually when damaged, contributing to reduce repair cost.

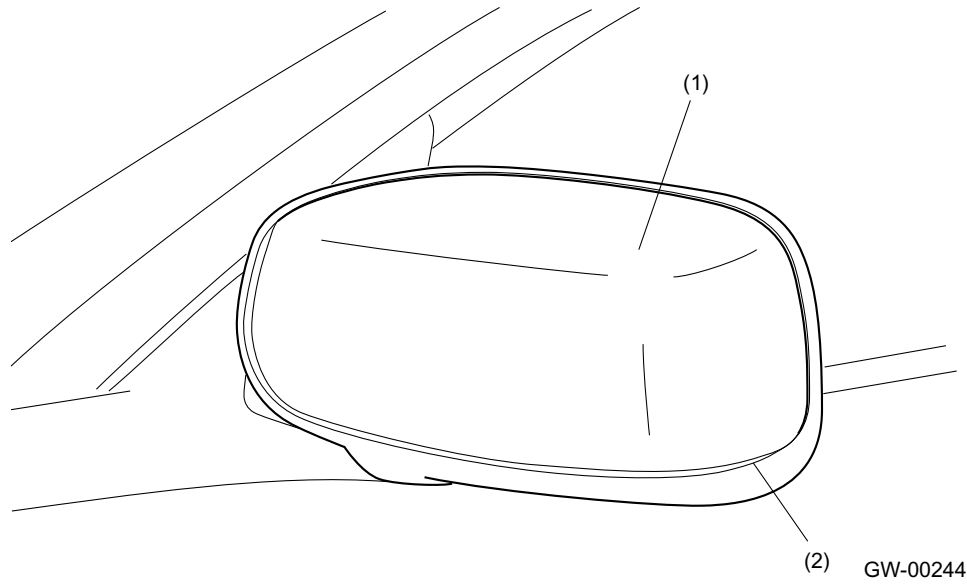

- (1) Scalp cap
- (2) Groove

GW-4