

Brought to you by Eris Studios
NOT FOR RESALE

INSTRUMENTATION DRIVER INFO

COMBINATION METER

INSTRUMENTATION/DRIVER INFO

1. Combination Meter

A: RED LUMINESCENT METER

To increase the product's desirability and visibility, a red luminescent meter is used on the STi models.

- Red LEDs are used for meter illumination.
- The brightness of the meter display area can be properly adjusted to meet various conditions.
- An indicator which illuminates when the lighting switch is turned to the next position from OFF is provided.

1. OPERATION

When the ignition switch is turned ON, the meter needle illuminates first and indicates the minimum position. Then the needle moves to the maximum position and the REV indicator flashes. After this the needle returns to the minimum position and the illumination and LCD turns ON. Finally the STi logo illuminates.

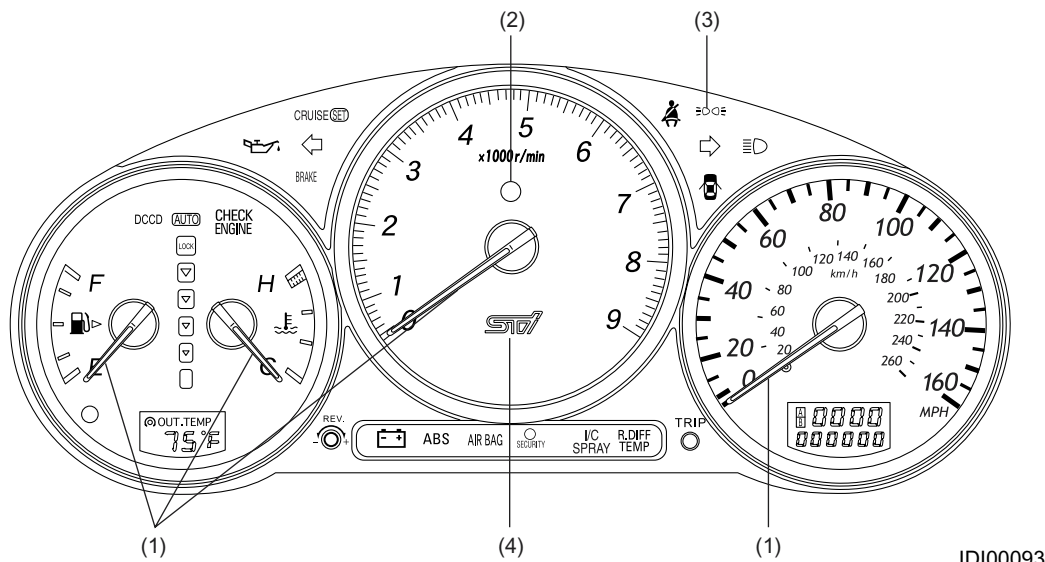

IDI00093

- (1) Needle
(2) REV indicator

- (3) Lights ON indicator
(4) STi logo

IDI-2

COMBINATION METER

INSTRUMENTATION/DRIVER INFO

2. BRIGHTNESS ADJUSTMENT

The illumination brightness can be adjusted by selecting any of the five steps of the lighting switch dial.

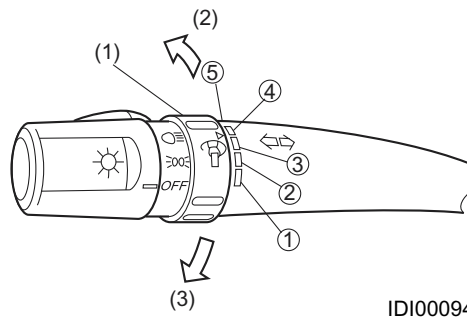

(1) Adjustment dial

(2) Brighter

(3) Darker

IDI-3

COMBINATION METER

INSTRUMENTATION/DRIVER INFO

B: WARNING AND INDICATOR LIGHTS

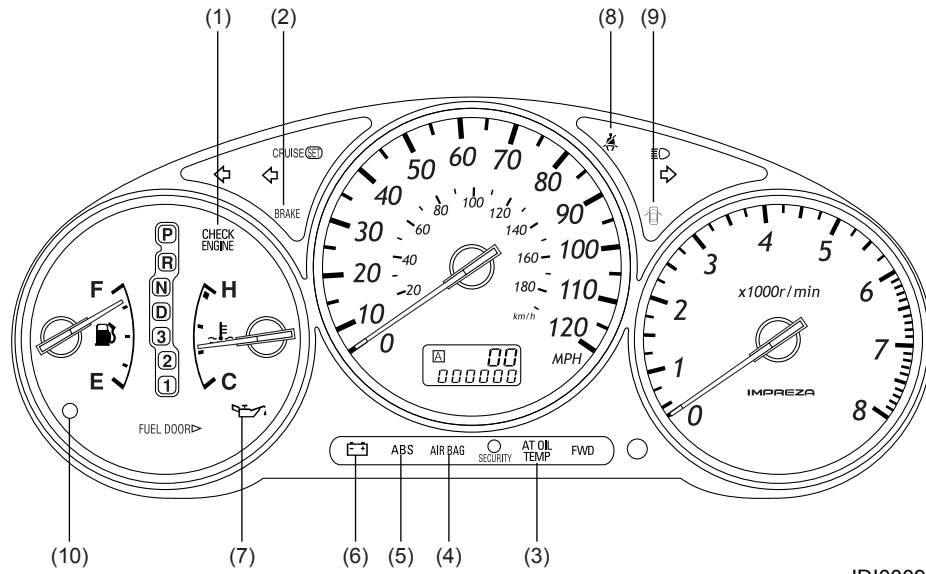

IDI00095

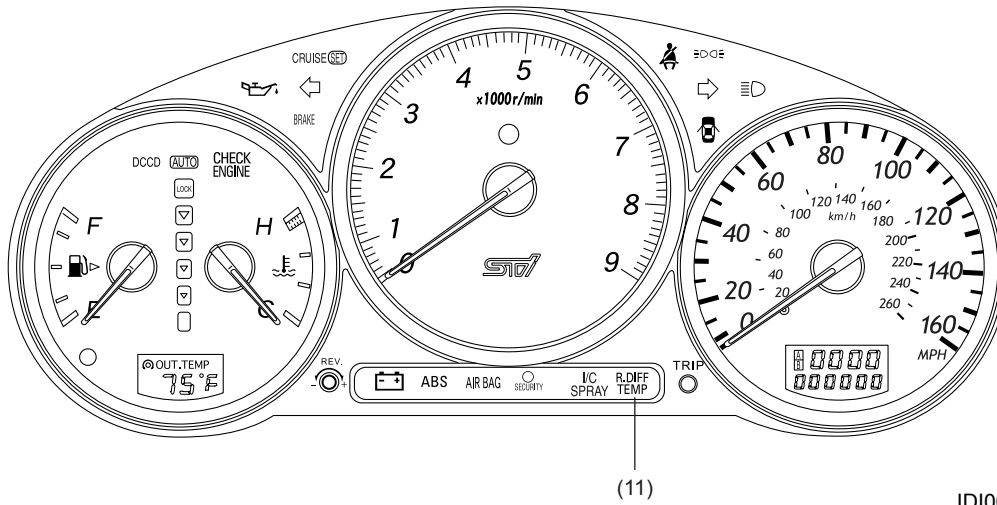

IDI00096

IDI-4

COMBINATION METER

INSTRUMENTATION/DRIVER INFO

- (1) CHECK ENGINE warning light
This light illuminates if a fault occurs in the MFI (Multiple point Fuel Injection) system.
- (2) Brake fluid level warning / parking brake indicator light
This light illuminates if the fluid level in the brake reservoir tank lowers below the specified level and/or when the parking brake is applied.
- (3) AT OIL TEMP warning light
This warning light illuminates when the ATF temperature exceeds 150°C (302°F); it blinks when a fault occurs in the AT control system.
- (4) AIR BAG system warning light
This warning light illuminates if a fault occurs in the airbag system.
- (5) ABS warning light
This warning light illuminates if a fault occurs in any electrical component of the ABS (Anti-lock Brake System).
- (6) Charge warning light
This warning light illuminates when a fault occurs in the charging system while the engine is running.
- (7) Oil pressure warning light
This light illuminates when the engine oil pressure decreases below 14.7 kPa (0.15 kgf/cm², 2.1 psi).
- (8) Seat belt warning light
This light stays illuminated for about 6 seconds after the ignition switch has been turned ON.
- (9) Door open warning light
This warning light illuminates when one or more doors and/or rear gate are not completely closed.
- (10) Low fuel warning light
This light illuminates when the quantity of the fuel remaining in the tank has decreased to 9 liters (2.4 US gal, 2.0 Imp gal) or less.
- (11) Rear differential oil temperature warning light
This warning light illuminates when the rear differential oil temperature exceeds 150°C (302°F).

When everything is normal, the warning and indicator lights should be ON or OFF as shown below according to ignition switch positions.

Warning/Indicator light		Ignition switch position			
		LOCK/ACC	ON	ST	While engine is running
(1)	CHECK ENGINE	OFF	ON	ON	OFF
(2)	Brake fluid level / parking brake	OFF	ON	ON	*1
(3)	AT OIL TEMP	OFF	ON	ON	OFF
(4)	AIR BAG	OFF	*2	*2	*2
(5)	ABS	OFF	*3	*3	*3
(6)	Charge	OFF	ON	ON	OFF
(7)	Oil pressure	OFF	ON	ON	OFF
(8)	Seat belt	OFF	*4	*4	*4
(9)	Door or rear gate open	● Open	ON	ON	ON
		● Closed	OFF	OFF	OFF
(10)	Low fuel level	OFF	*5	*5	*5
(11)	Rear differential oil temperature	OFF	ON	ON	OFF

*1: This warning light comes ON when the parking brake is applied.

*2: This warning light comes ON for about 6 seconds, and then goes out.

*3: This warning light comes ON for about 2 seconds, and then goes out.

*4: This warning light stays illuminated for about 6 seconds after the ignition switch has been turned ON if the drivers seat belt is NOT fastened.

*5: This light illuminates when the quantity of the fuel remaining in the tank has decreased to 9 liters (2.4 US gal, 2.0 Imp gal) or less.

IDI-5

COMBINATION METER

INSTRUMENTATION/DRIVER INFO

C: TELLTALE LIGHTS

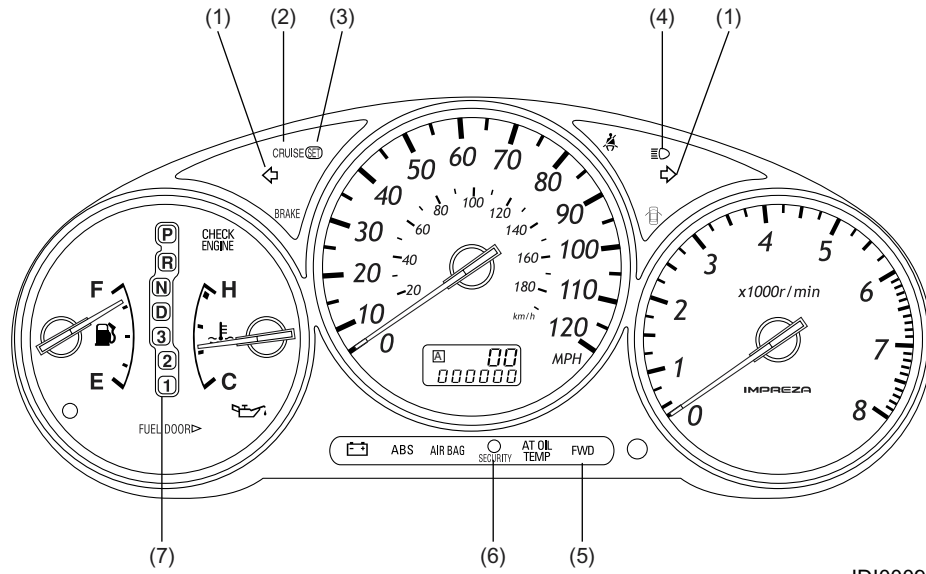

IDI00097

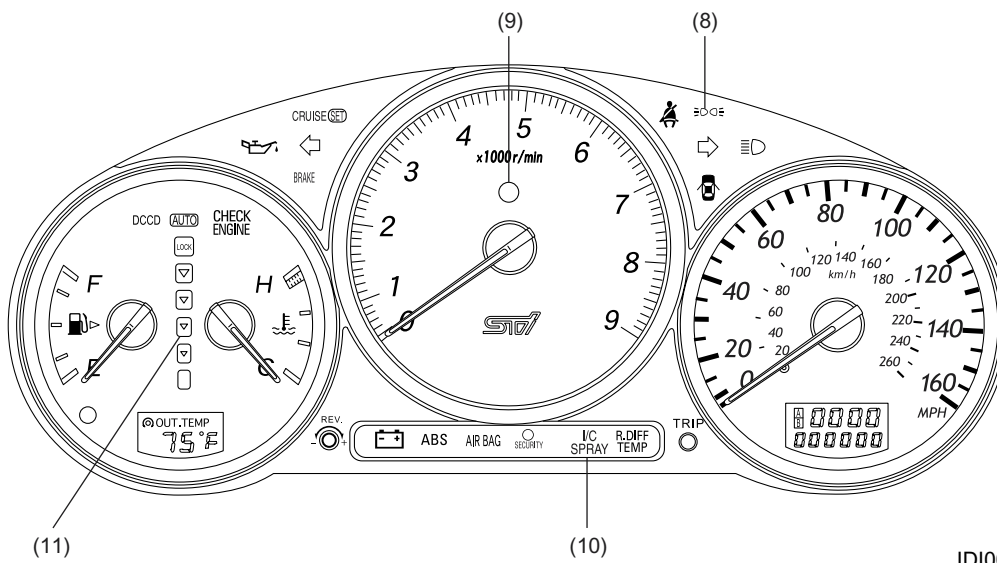

IDI00098

IDI-6

COMBINATION METER

INSTRUMENTATION/DRIVER INFO

- (1) Turn signal indicator
This indicator blinks in unison with the corresponding turn signal lights when the turn signal switch is operated.
- (2) CRUISE indicator
This indicator illuminates when the cruise control main switch is turned ON.
- (3) SET indicator
This indicator illuminates when the cruise control main switch is turned ON and the SET/COAST switch on the command switch is turned ON.
- (4) Headlight beam indicator
This indicator illuminates when the headlights are in the high-beam position.
- (5) FWD indicator
This indicator illuminates when the drive mode is changed from AWD to FWD (with the fuse installed in the FWD switch).
- (6) Security indicator
This indicator illuminates when the security system is armed.
- (7) AT selector lever position indicator
The indicator corresponding to the present AT select lever position illuminates when the ignition switch is in any position other than ACC and LOCK.
- (8) Lighting switch indicator
Turns on when the lighting switch is turned to the next position from OFF.
- (9) REV indicator
This indicator illuminates while the preset engine speed is exceeded.
- (10) Intercooler water spray level warning light
This warning light illuminates when the water level in the intercooler water spray tank lowers.
- (11) Driver-controllable center differential indicator
Indicates the degree of differential lock engagement in six steps. The AUTO light illuminates when auto is selected.

IDI-7

COMBINATION METER

INSTRUMENTATION/DRIVER INFO

When everything is normal, the telltales should be ON, OFF or in other states as shown below according to ignition switch position.

Telltale lights		Ignition switch position			
		LOCK/ACC	ON	ST	While engine is running
(1)	Turn signal	OFF	Blink	Blink	Blink
(2)	CRUISE	OFF	OFF	OFF	ON
(3)	SET	OFF	OFF	OFF	*1
(4)	Headlight beam	• High beam	OFF	ON	ON
		• Low beam	OFF	OFF	OFF
(5)	FWD	• FWD	OFF	ON	ON
		• 4WD	OFF	OFF	OFF
(6)	Security	*2	OFF	OFF	OFF
(7)	AT selector lever position	OFF	ON	ON	ON
(8)	Lighting switch	OFF	*3	*3	*3
(9)	REV indicator	OFF	OFF	OFF	*4
(10)	Intercooler water spray level	OFF	*5	*5	*5
(11)	Driver-controllable center differential	OFF	*6	*6	*6

*1: This light illuminates when the SET/COAST switch is turned ON while driving at 40 km/h (25 MPH) or higher.

*2: This light illuminates when the security system is armed.

*3: Turns on when the lighting switch is turned to the next position from OFF.

*4: This light illuminates while the preset engine speed is exceeded.

*5: This light illuminates when the water level in the tank lowers to 0.4 liters.

*6: Indicates the current degree of differential lock engagement.

IDI-8

COMBINATION METER

INSTRUMENTATION/DRIVER INFO

D: SPEEDOMETER

1. GENERAL

- The speedometer system is an electrical type that uses electric signals from the speed sensor in MT models or the transmission control module in AT models.
- The vehicle speed sensor is installed on the manual transmission.
- Since the system does not use mechanical components such as rotating cable, there are no opportunities of occurring such problems as meter needle vibration and cable disconnection. Also, it does not constitute any means of mechanical noise transmission.
- The odometer and trip meter readings appear on a liquid crystal display (LCD).

2. OPERATION

MT models: The vehicle speed sensor sends vehicle speed signals (4 pulses per rotation of speed sensor's driven shaft) to the speedometer drive circuit and odometer/trip meter drive circuit in the speedometer.

AT models: The TCM sends vehicle speed signals (4 pulses per rotation of output shaft) to the speedometer drive circuit and odometer/trip meter drive circuit in the speedometer.

NOTE:

Signals from the speed sensor or TCM are also used by the engine control module, automatic transmission control module, etc.

3. SPECIFICATIONS

Speedometer	Type	Electric pulse type.
	Indication	Needle points to 60 km/h (37.3 MPH) when 2,548 pulses are input per minute.
Odometer	Type	Pulse count type
	Display	LCD/6 digits; 0 to 999,999 km (mile).
	Indication	Counts up 1 km per 2,548 pulses (1 mile per 4,104 pulses). (Count down is impossible.)
Trip meter	Type	Pulse count type
	Display	LCD/4 digits; 0 to 999.9 km (mile) and 1000 to 9999 km (mile).
	Indication	Counts up 1 km per 2,548 pulses (1 mile per 4,104 pulses). (To change the trip meter from A to B or B to A, push the knob momentarily. To return the trip meter to zero indication, keep the knob pushed for more than 1 second.)

IDI-9

COMBINATION METER

INSTRUMENTATION/DRIVER INFO

4. SYSTEM DIAGRAM

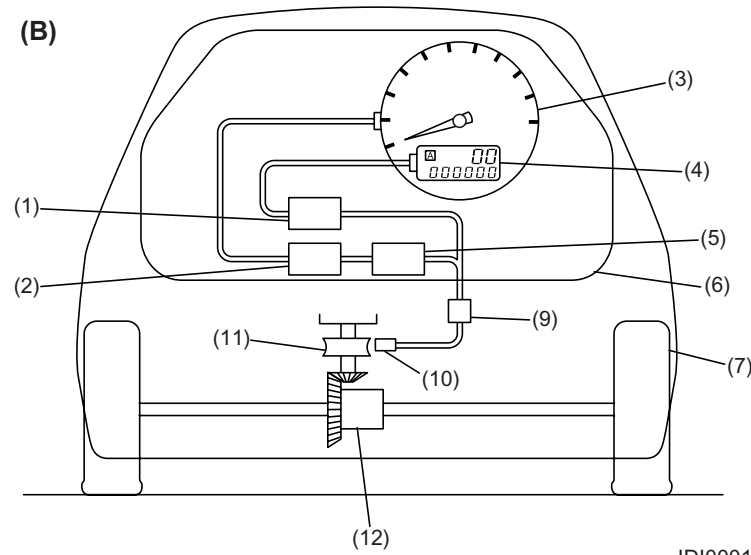
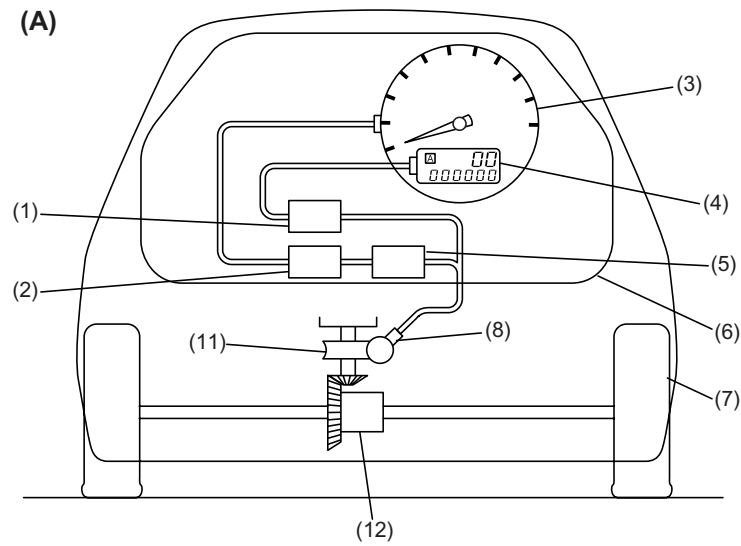

IDI00012

(A) MT models

(B) AT models

(1) Odometer/trip meter drive circuit

(2) Speedometer movement

(3) Speedometer

(4) Odometer/trip meter

(5) Speedometer drive circuit

(6) Combination meter

(7) Front wheel

(8) Speed sensor

(9) TCM

(10) Electromagnetic pick-up

(11) Gear for the speed sensor

(12) Differentials

IDI-10

COMBINATION METER

INSTRUMENTATION/DRIVER INFO

E: VEHICLE SPEED SENSOR

The vehicle speed sensor uses a Hall IC pick-up to generate speed signals (MT models).

This sensor is installed on the transmission case and detects rotating speed of the transmission output gear.

The sensor generates 4 pulses per rotation of the speed sensor driven shaft and send them to the speedometer.

1. CONSTRUCTION

The speed sensor mainly consists of a Hall IC, magnet ring, driven shaft and spring.

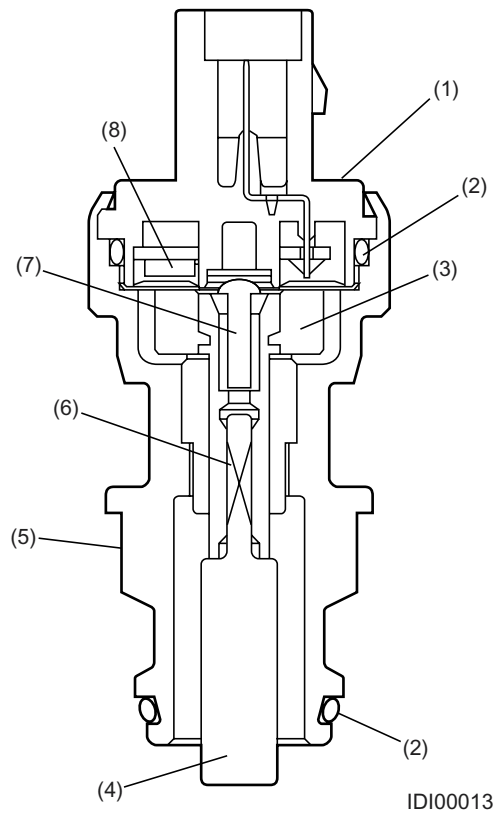

IDI00013

- (1) Upper case
- (2) O-ring
- (3) Magnet ring

- (4) Driven key
- (5) Lower case
- (6) Driven shaft

- (7) Rivet
- (8) Hall IC

IDI-11

COMBINATION METER

INSTRUMENTATION/DRIVER INFO

2. OPERATION

As the driven key rotates, the magnet turns causing the magnetic field of the Hall IC to change. The Hall IC generates a signal that corresponds to a change in the magnetic field.

One turn of the driven key in the speed sensor sends 4 pulses to the combination meter, engine control module and cruise control module.

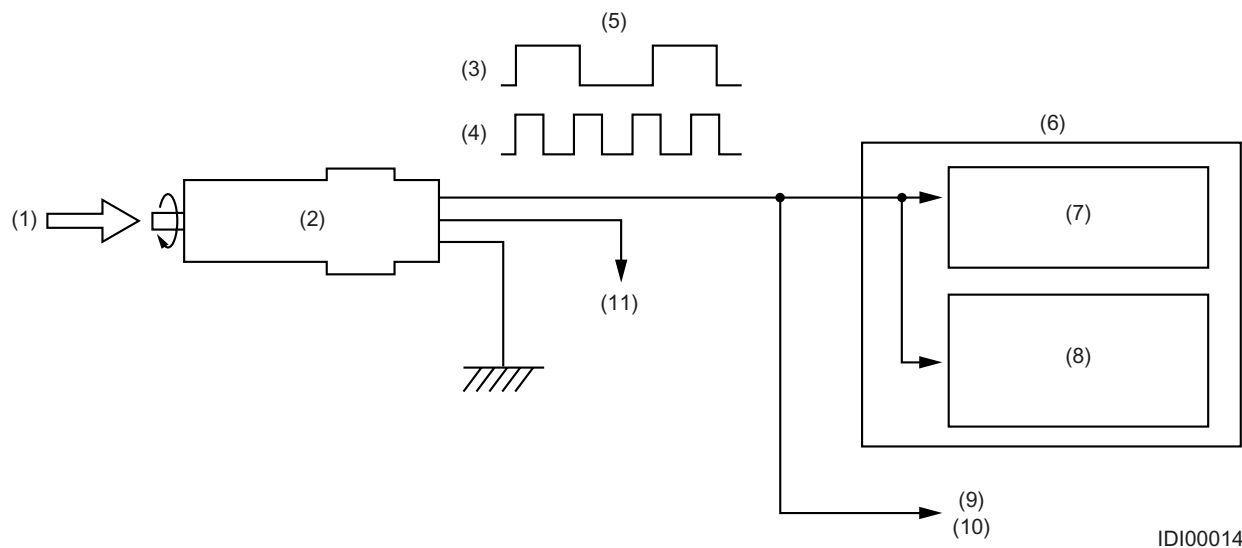

- | | |
|--|---|
| (1) Revolution of transmission output gear | (7) Speedometer drive circuit |
| (2) Vehicle speed sensor | (8) Odometer and trip meter drive circuit |
| (3) Low-speed | (9) Engine control unit |
| (4) High-speed | (10) Cruise control module |
| (5) Signal (4 pulses per revolution) | (11) Ignition switch |
| (6) Combination meter | |

IDI-12

COMBINATION METER

INSTRUMENTATION/DRIVER INFO

F: TACHOMETER

The tachometer drive circuit is connected to the engine speed sensing circuit in the engine control module.

When the engine speed increases or decreases, the voltage of the circuit also increases or decreases, changing the magnetic force of the tachometer drive coil.

The tachometer needle then moves in accordance with change in the engine speed.

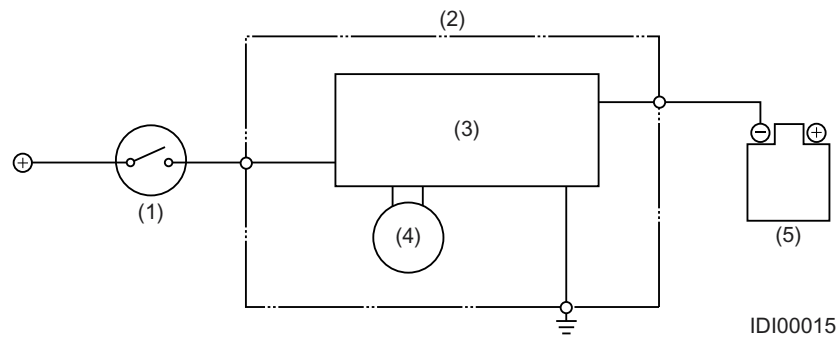

- (1) Ignition switch
- (2) Combination meter
- (3) Tachometer drive circuit

- (4) Tachometer
- (5) ECM

IDI-13

COMBINATION METER

INSTRUMENTATION/DRIVER INFO

G: WATER TEMPERATURE GAUGE

- The water temperature signal is sent from the water temperature sensor located on the engine.
- The resistance of the water temperature sensor changes according to the engine coolant temperature. Therefore, the current sent to the water temperature gauge also changes according to the engine coolant temperature. As the change in current causes the magnetic force of the coil to change, the gauge's needle moves according to the engine coolant temperature.
- When the coolant is at a normal operating temperature of approx. 70 to 100°C (158 to 212°F), the gauge's needle stays in the middle of the indication range as shown below.

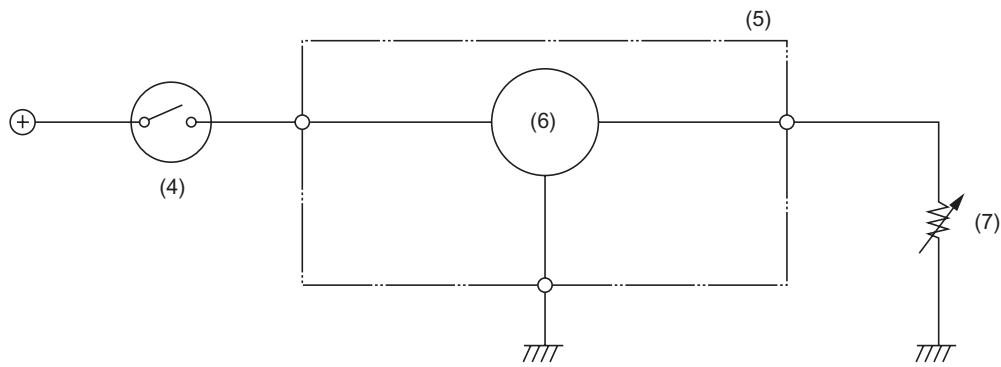
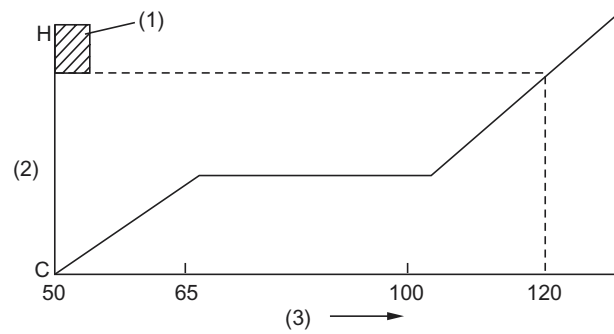

IDI00016

- | | |
|----------------------|---------------------------------------|
| (1) Red zone | (5) Combination meter |
| (2) Indication | (6) Water temperature gauge |
| (3) Temperature (°C) | (7) Engine coolant temperature sensor |
| (4) Ignition switch | |

IDI-14

COMBINATION METER

INSTRUMENTATION/DRIVER INFO

H: FUEL GAUGE

1. GENERAL

- The fuel gauge unit consists of a float and a potentiometer whose resistance varies depending on movement of the float. It is located inside the fuel tank and forms an integral part of the fuel pump. The fuel gauge for models except STi indicates the fuel level in the tank even when the ignition switch is in the LOCK position. The fuel gauge for STi models indicates the fuel level in the tank when the ignition switch is in the ON position.
- All models are equipped with two fuel level sensors. These sensors are installed in the fuel tank, one on the right side and the other on the left side. Two sensors are necessary because the fuel tank is divided into main and sub tank compartments.

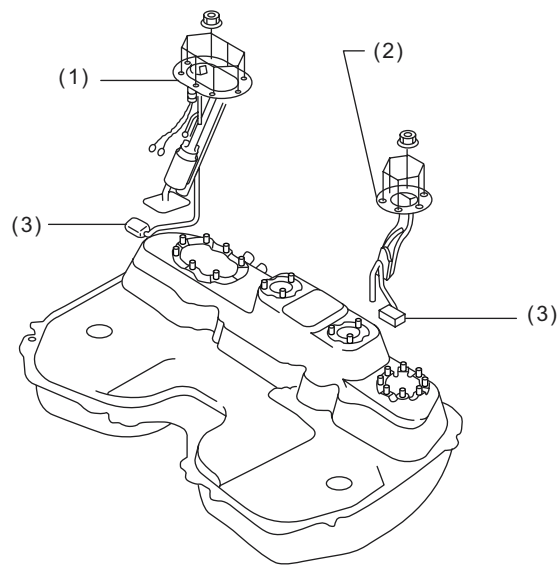

IDI00017

- (1) Main fuel level sensor
- (2) Sub fuel level sensor
- (3) Float

IDI-15

COMBINATION METER

INSTRUMENTATION/DRIVER INFO

2. OPERATION

The low fuel warning light operates as follows:

The ECM continually monitors the resistance signal from the fuel level sensor. It turns on the low fuel warning light in the combination meter if a resistance value corresponding to the critical fuel level is detected for a certain time while driving.

This monitoring time has been decided to avoid false operation of the warning light which may happen when a large part of remaining fuel is collected temporarily in the sub tank compartment.

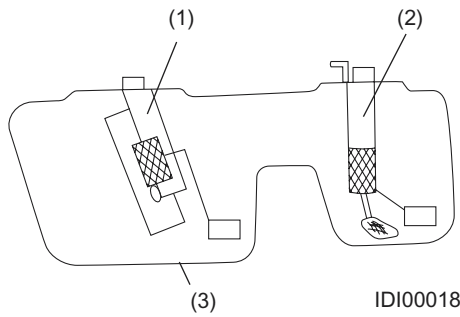

- (1) Main fuel level sensor
- (2) Sub fuel level sensor
- (3) Fuel tank

3. SPECIFICATIONS

	Fuel level	Resistance
Main fuel level sensor	Full	0.5 — 2.5Ω
	1/2	20.7 — 24.7Ω
	Empty	50.0 — 52.0Ω
Sub fuel level sensor	Full	0.5 — 2.5Ω
	1/2	19.5 — 23.5Ω
	Empty	42.0 — 44.0 Ω

IDI-16

COMBINATION METER

INSTRUMENTATION/DRIVER INFO

4. SCHEMATIC DRAWINGS

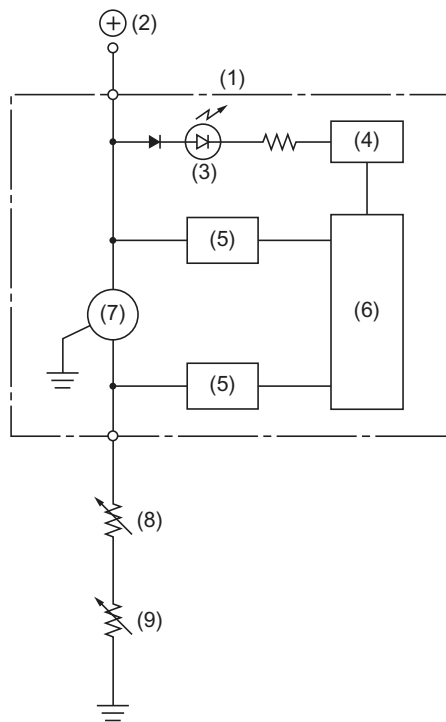

IDI00019

- | | |
|----------------------------|----------------------------|
| (1) Combination meter | (6) CUSTOM CPU |
| (2) Ignition switch | (7) Fuel gauge |
| (3) Low fuel warning light | (8) Sub fuel level sensor |
| (4) Driver circuit | (9) Main fuel level sensor |
| (5) Interface | |

IDI-17

OUTSIDE AIR TEMPERATURE DISPLAY

INSTRUMENTATION/DRIVER INFO

2. Outside Air Temperature Display

A: CONSTRUCTION

The outside air temperature display system consists of an ambient sensor, the CUSTOM CPU and a liquid crystal display installed in the combination meter. The ambient sensor detects the outside air temperature using the built-in thermistor which varies its resistance according to change in ambient temperature, and sends signals to the CUSTOM CPU.

As soon as the ignition switch is turned ON, the CUSTOM CPU compares the temperature data sent from the ambient sensor with the one that was stored in its memory when the ignition switch was turned OFF last time and it causes the lower of the temperatures to be displayed. However, if 60 minutes or more time has passed between the last turning OFF and the next turning ON of the ignition switch, the temperature that is displayed is a sensor-provided temperature.

When the vehicle is running slowly, the heat released from the engine compartment raises the temperature of the air around the ambient sensor and this affects the temperature data the sensor sends to the CUSTOM CPU. The CPU then makes a special control using the vehicle speed data, i.e., when the vehicle is running at a speed slower than 10 km/h, the CPU uses the temperature that was detected during the most recent vehicle's movement at a speed exceeding 10 km/h rather than a temperature currently being provided by the ambient sensor.

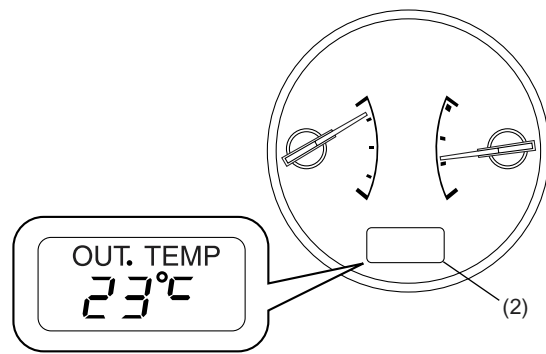
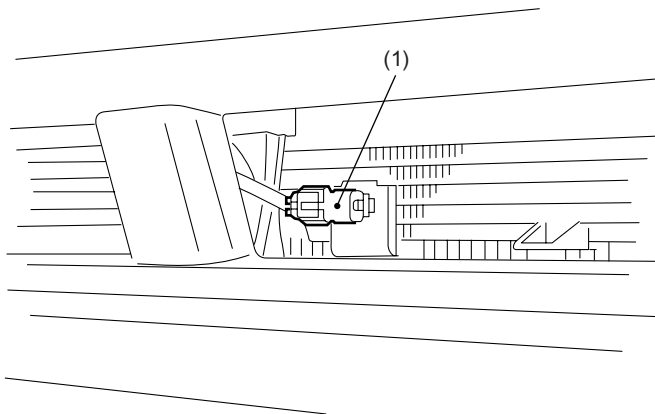

IDI00071

- (1) Ambient sensor
- (2) Outside air temperature display

OUTSIDE AIR TEMPERATURE DISPLAY

INSTRUMENTATION/DRIVER INFO

B: SCHEMATIC DRAWINGS

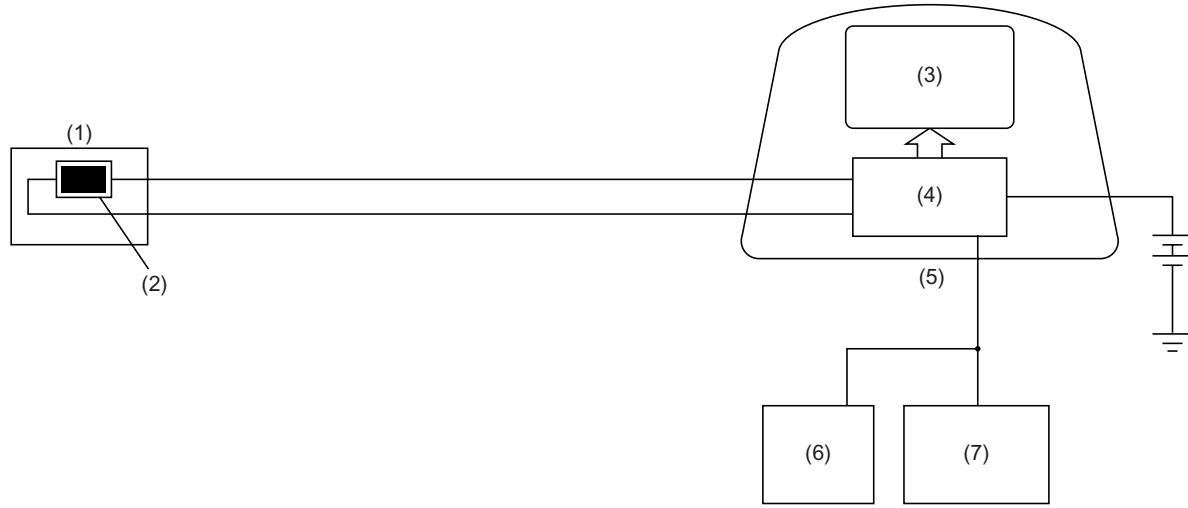

IDI00021

- (1) Ambient sensor
- (2) Thermistor
- (3) Outside air temperature display
- (4) CUSTOM CPU

- (5) Combination meter
- (6) Vehicle speed sensor (MT)
- (7) Transmission control module (AT)

OUTSIDE AIR TEMPERATURE DISPLAY

INSTRUMENTATION/DRIVER INFO

MEMO

IDI-20