

Brought to you by Eris Studios  
NOT FOR RESALE

# ENGINE (DIAGNOSTICS)

# BASIC DIAGNOSTIC PROCEDURE

ENGINE (DIAGNOSTICS)

## 1. Basic Diagnostic Procedure

### A: PROCEDURE

#### 1. ENGINE

Step	Check	Yes	No
<b>1 CHECK ENGINE START FAILURE.</b> 1) Ask the customer when and how trouble occurred using the interview check list. <Ref. to EN(STi)-3, CHECK, Check List for Interview.> 2) Start the engine.	Does the engine start?	Go to step 2.	Inspection using "Diagnostics for Engine Start Failure". <Ref. to EN(STi)-54, Diagnostics for Engine Starting Failure.>
<b>2 CHECK ILLUMINATION OF MALFUNCTION INDICATOR LIGHT.</b>	Does the malfunction indicator light illuminate?	Go to step 3.	Inspection using "General Diagnostics Table". <Ref. to EN(STi)-359, General Diagnostic Table.>
<b>3 CHECK INDICATION OF DTC ON DISPLAY.</b> 1) Turn the ignition switch to OFF. 2) Connect the Subaru Select Monitor or OBD-II general scan tool to data link connector. 3) Turn the ignition switch to ON and the Subaru Select Monitor or OBD-II general scan tool switch to ON. 4) Read the DTC on Subaru Select Monitor or OBD-II general scan tool.	Does the Subaru Select Monitor or OBD-II general scan tool indicate DTC?	Record the DTC code. Repair the trouble cause. <Ref. to EN(STi)-66, List of Diagnostic Trouble Code (DTC).> Go to step 4.	Repair the related parts.  NOTE: If a DTC is not shown on display although malfunction indicator light illuminates, perform diagnostics of malfunction indicator light circuit or combination meter. <Ref. to EN(STi)-45, Malfunction Indicator Light.>
<b>4 PERFORM THE DIAGNOSIS.</b> 1) Perform the clear memory mode. <Ref. to EN(STi)-42, Clear Memory Mode.> 2) Perform the inspection mode. <Ref. to EN(STi)-35, Inspection Mode.>	Does the Subaru Select Monitor or OBD-II general scan tool indicate DTC?	Inspect using "Diagnostics Procedure with Diagnostic Trouble Code (DTC)". <Ref. to EN(STi)-73, Diagnostic Procedure with Diagnostic Trouble Code (DTC).>	Complete the diagnosis.

# CHECK LIST FOR INTERVIEW

ENGINE (DIAGNOSTICS)

## 2. Check List for Interview

### A: CHECK

#### 1. CHECK LIST NO. 1

Check the following items when problem has occurred.

NOTE:

Use copies of this page for interviewing customers.

Customer's name		Engine No.	
Date of sale		Fuel brand	
Date of repair		Odometer reading	km
VIN			miles
Weather	<input type="checkbox"/> Fine <input type="checkbox"/> Cloudy <input type="checkbox"/> Rainy <input type="checkbox"/> Snowy <input type="checkbox"/> Various/Others:		
Outdoor temperature	°C (°F)		
	<input type="checkbox"/> Hot <input type="checkbox"/> Warm <input type="checkbox"/> Cool <input type="checkbox"/> Cold		
Place	<input type="checkbox"/> Highway <input type="checkbox"/> Suburbs <input type="checkbox"/> Inner city <input type="checkbox"/> Uphill <input type="checkbox"/> Downhill <input type="checkbox"/> Rough road <input type="checkbox"/> Others:		
	<input type="checkbox"/> Cold <input type="checkbox"/> Warming-up <input type="checkbox"/> After warming-up <input type="checkbox"/> Any temperature <input type="checkbox"/> Others:		
Engine speed	rpm		
Vehicle speed	MPH		
Driving conditions	<input type="checkbox"/> Not affected <input type="checkbox"/> At starting <input type="checkbox"/> While idling <input type="checkbox"/> At racing <input type="checkbox"/> While accelerating <input type="checkbox"/> While cruising <input type="checkbox"/> While decelerating <input type="checkbox"/> While turning (RH/LH)		
Headlight	<input type="checkbox"/> ON/ <input type="checkbox"/> OFF	Rear defogger	<input type="checkbox"/> ON/ <input type="checkbox"/> OFF
Blower	<input type="checkbox"/> ON/ <input type="checkbox"/> OFF	Radio	<input type="checkbox"/> ON/ <input type="checkbox"/> OFF
A/C compressor	<input type="checkbox"/> ON/ <input type="checkbox"/> OFF	CD/Cassette	<input type="checkbox"/> ON/ <input type="checkbox"/> OFF
Cooling fan	<input type="checkbox"/> ON/ <input type="checkbox"/> OFF	Car phone	<input type="checkbox"/> ON/ <input type="checkbox"/> OFF
Front wiper	<input type="checkbox"/> ON/ <input type="checkbox"/> OFF	CB	<input type="checkbox"/> ON/ <input type="checkbox"/> OFF
Rear wiper	<input type="checkbox"/> ON/ <input type="checkbox"/> OFF		

# CHECK LIST FOR INTERVIEW

ENGINE (DIAGNOSTICS)

## 2. CHECK LIST NO. 2

Check the following items about the vehicle's state when malfunction indicator light turns on.

NOTE:

Use copies of this page for interviewing customers.

a) Other warning lights or indicators turn on. <input type="checkbox"/> Yes/ <input type="checkbox"/> No
<input type="checkbox"/> Low fuel warning light <input type="checkbox"/> Charge indicator light <input type="checkbox"/> AT diagnostics indicator light <input type="checkbox"/> ABS warning light <input type="checkbox"/> Engine oil pressure warning light
b) Fuel level
<ul style="list-style-type: none"><li>• Lack of gasoline: <input type="checkbox"/> Yes/<input type="checkbox"/> No</li><li>• Indicator position of fuel gauge:</li><li>• Had run out of gas before: <input type="checkbox"/> Yes/<input type="checkbox"/> No</li></ul>
c) Intentional connecting or disconnecting of harness connectors or spark plug cords: <input type="checkbox"/> Yes/ <input type="checkbox"/> No
<ul style="list-style-type: none"><li>• What:</li></ul>
d) Intentional connecting or disconnecting of hoses: <input type="checkbox"/> Yes/ <input type="checkbox"/> No
<ul style="list-style-type: none"><li>• What:</li></ul>
e) Installing of parts other than genuine parts: <input type="checkbox"/> Yes/ <input type="checkbox"/> No
<ul style="list-style-type: none"><li>• What:</li><li>• Where:</li></ul>
f) Occurrence of noise: <input type="checkbox"/> Yes/ <input type="checkbox"/> No
<ul style="list-style-type: none"><li>• From where:</li><li>• What kind:</li></ul>
g) Occurrence of smell: <input type="checkbox"/> Yes/ <input type="checkbox"/> No
<ul style="list-style-type: none"><li>• From where:</li><li>• What kind:</li></ul>
h) Intrusion of water into engine compartment or passenger compartment: <input type="checkbox"/> Yes/ <input type="checkbox"/> No
i) Troubles occurred
<input type="checkbox"/> Engine does not start. <input type="checkbox"/> Engine stalls during idling. <input type="checkbox"/> Engine stalls while driving. <input type="checkbox"/> Engine speed decreases. <input type="checkbox"/> Engine speed does not decrease. <input type="checkbox"/> Rough idling <input type="checkbox"/> Poor acceleration <input type="checkbox"/> Back fire <input type="checkbox"/> After fire <input type="checkbox"/> No shift <input type="checkbox"/> Excessive shift shock

### 3. General Description

#### A: CAUTION

1) Airbag system wiring harness is routed near the ECM, main relay and fuel pump relay.

#### CAUTION:

- All airbag system wiring harness and connectors are colored yellow. Do not use the electrical test equipment on these circuit.
- Be careful not to damage the airbag system wiring harness when servicing the ECM, TCM, main relay and fuel pump relay.

2) Never connect the battery in reverse polarity.

- The ECM will be destroyed instantly.
- The fuel injector and other part will be damaged in just a few minutes more.

3) Do not disconnect the battery cables while the engine is running.

- A large counter electromotive force will be generated in the alternator, and this voltage may damage electronic parts such as ECM, etc.

4) Before disconnecting the connectors of each sensor and the ECM, be sure to turn the ignition switch to OFF.

5) Poor contact has been identified as a primary cause of this problem. To measure the voltage and/or resistance of individual sensors or all electrical control modules at the harness side connector, use a tapered pin with a diameter of less than 0.64 mm (0.025 in). Do not insert the pin more than 5 mm (0.20 in) into the part.

6) Before removing the ECM from located position, disconnect two cables on battery.

- Otherwise, the ECM may be damaged.

#### CAUTION:

**When replacing the ECM, be careful not to use the wrong spec. ECM to avoid any damage on the fuel injection system.**

7) The connectors to each sensor in the engine compartment and the harness connectors on the engine side and body side are all designed to be waterproof. However, it is still necessary to take care not to allow water to get into the connectors when washing the vehicle, or when servicing the vehicle on a rainy day.

8) Use the ECM mounting stud bolt at the body head grounding points when measuring voltage and resistance inside the passenger compartment.

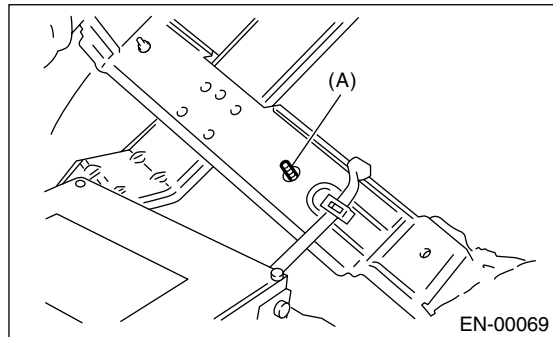

(A) Stud bolt

9) Use the engine grounding terminal or engine proper as the grounding point to the body, when measuring voltage and resistance in the engine compartment.

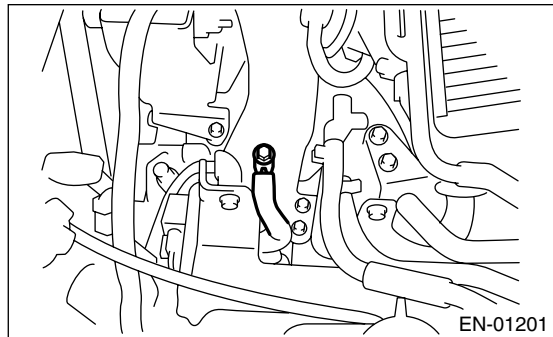

10) Every MFI-related part is a precision part. Do not drop them.

11) Observe the following cautions when installing a radio in MFI equipped models.

#### CAUTION:

- The antenna must be kept as far apart as possible from the control unit.

**(The ECM is located under the steering column, inside of the instrument panel lower trim panel.)**

- The antenna feeder must be placed as far as possible from ECM and MFI harness.

- Carefully adjust the antenna for correct matching.

- When mounting a large power type radio, pay special attention to the three items above mentioned.

- Incorrect installation of the radio may affect the operation of ECM.

12) Before disconnecting the fuel hose, disconnect the fuel pump connector and crank the engine for more than 5 seconds to release pressure in the fuel system. If the engine starts during this operation, run it until it stops.

# GENERAL DESCRIPTION

## ENGINE (DIAGNOSTICS)

13) Diagnostics should be conducted by rotating with simple, easy operations and proceeding to complicated, difficult operations. The most important thing in diagnostics is to understand the customer's complaint, and distinguish between the three causes.

14) On model with ABS, when performing driving test in jacked-up or lifted-up position, sometimes the warning light may be lit, but this is not a malfunction of the system. The reason for this is the speed difference between front and rear wheels. After diagnosis of engine control system, perform the ABS memory clearance procedure of self-diagnosis system.

### B: INSPECTION

Before performing diagnostics, check the following items which might affect engine problems:

#### 1. BATTERY

1) Measure the battery voltage and specific gravity of electrolyte.

**Standard voltage: 12 V**

**Specific gravity: Above 1.260**

2) Check the condition of main and other fuses, and harnesses and connectors. Also check for proper grounding.

#### 2. ENGINE GROUNDING

Make sure the engine grounding terminal is properly connected to engine.

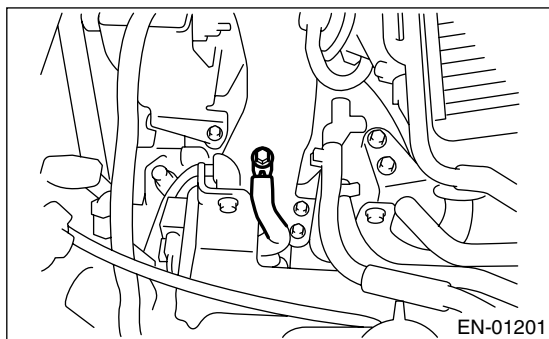

### C: NOTE

#### 1. DESCRIPTION

- The on-board diagnostics (OBD) system detects and indicates a fault in various inputs and outputs of complex electronic control. Malfunction indicator light in combination meter indicates occurrence of a fault or trouble.
- Further, against such a failure or sensors as may disable the drive, the fail-safe function is provided to ensure the minimal driveability.
- The OBD system incorporated with the vehicles within this engine family complies with Section 1968.1, California Code of Regulations (OBD-II regulation). The OBD system monitors the components and the system malfunction listed in Engine Section which affects on emissions.
- When the system decides that a malfunction occurs, malfunction indicator light illuminates. At the same time of malfunction indicator light illumination or blinking, a DTC and a freeze frame engine conditions are stored into on-board computer.
- The OBD system stores freeze frame engine condition data (engine load, engine coolant temperature, fuel trim, engine speed and vehicle speed, etc.) into on-board computer when it detects a malfunction first.
- If the OBD system detects the various malfunctions including the fault of fuel trim or misfire, the OBD system first stores freeze frame engine conditions about the fuel trim or misfire.
- When the malfunction does not occur again for three consecutive driving cycles, malfunction indicator light is turned off, but DTC remains at on-board computer.
- The OBD-II system is capable of communication with a general scan tool (OBD-II general scan tool) formed by ISO 9141 CARB.
- The OBD-II diagnostics procedure is different from usual diagnostics procedure. When troubleshooting model with OBD-II, connect the Subaru Select Monitor or the OBD-II general scan tool to the vehicle.

# GENERAL DESCRIPTION

ENGINE (DIAGNOSTICS)

## 2. ENGINE AND EMISSION CONTROL SYSTEM

• The Multipoint Fuel Injection (MFI) system is a system that supplies the optimum air-fuel mixture to the engine for all the various operating conditions through the use of the latest electronic technology.

With this system fuel, which is pressurized at a constant pressure, is injected into the intake air passage of the cylinder head. The injection quantity of fuel is controlled by an intermittent injection system where the electro-magnetic injection valve (fuel injector) opens only for a short period of time, depending on the quantity of air required for one cycle of operation. In actual operation, the injection quantity is determined by the duration of an electric



pulse applied to the fuel injector and this permits simple, yet highly precise metering of the fuel.

• Further, all the operating conditions of the engine are converted into electric signals, and this results in additional features of the system, such as large improved adaptability, easier addition of compensating element, etc.

The MFI system also has the following features:

- Reduced emission of harmful exhaust gases.
- Reduced in fuel consumption.
- Increased engine output.
- Superior acceleration and deceleration.
- Superior startability and warm-up performance in cold weather since compensation is made for coolant and intake air temperature.

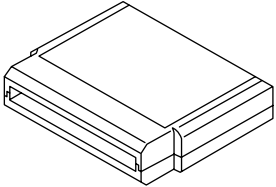
## D: PREPARATION TOOL

ILLUSTRATION	TOOL NUMBER	DESCRIPTION	REMARKS
 ST24082AA230	24082AA230	CARTRIDGE	Troubleshooting for electrical systems.
 ST22771AA030	22771AA030	SUBARU SELECT MONITOR KIT	Troubleshooting for electrical systems.

# ELECTRICAL COMPONENTS LOCATION

ENGINE (DIAGNOSTICS)

## 4. Electrical Components Location

### A: LOCATION

#### 1. ENGINE

- Module

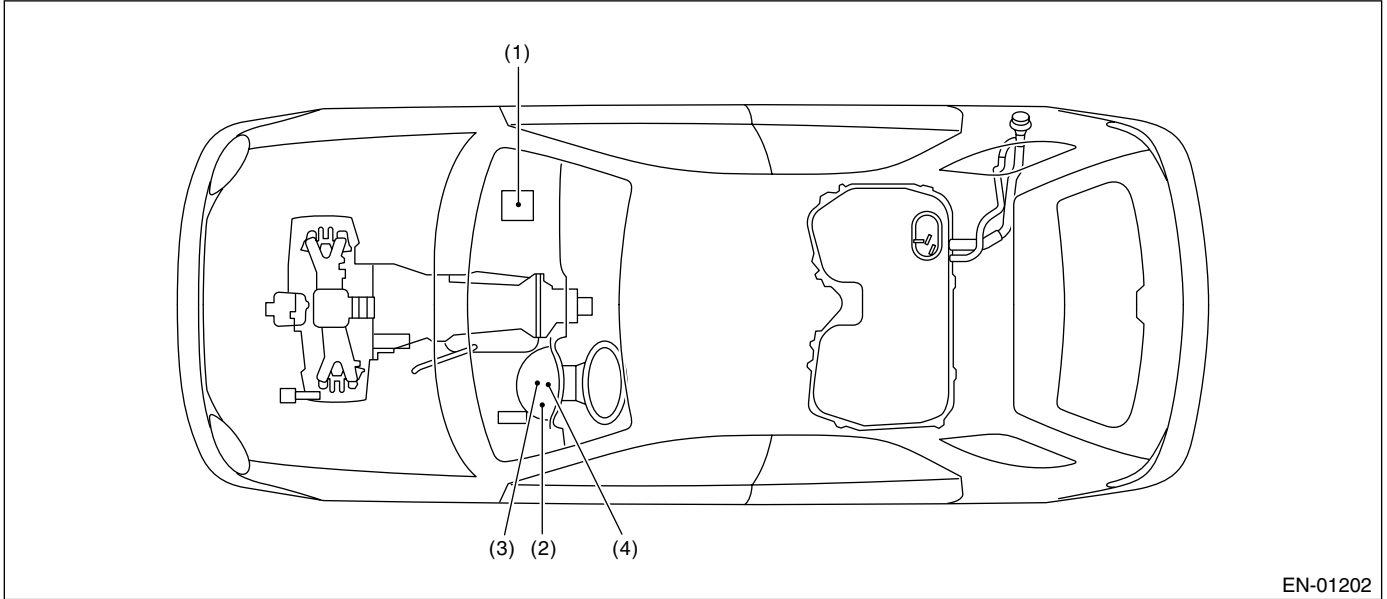

EN-01202

(1) Engine control module (ECM)

(3) Data link connector

(4) Test mode connector

(2) Malfunction indicator light

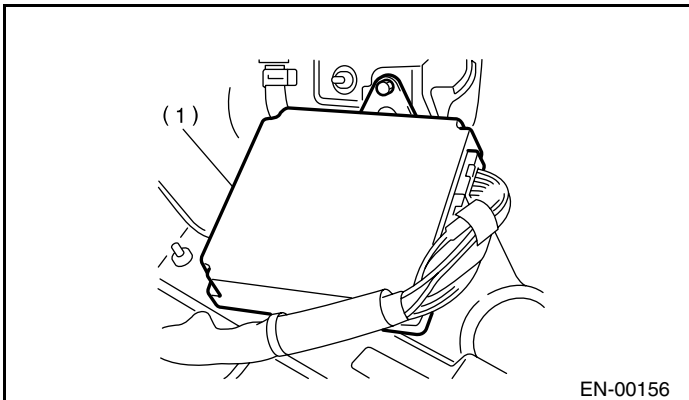

EN-00156

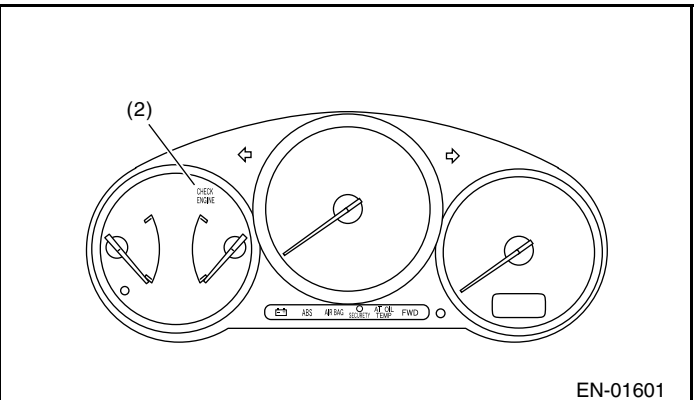

EN-01601

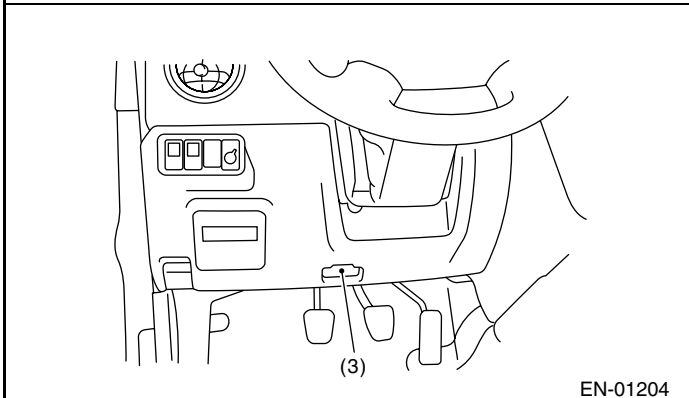

EN-01204

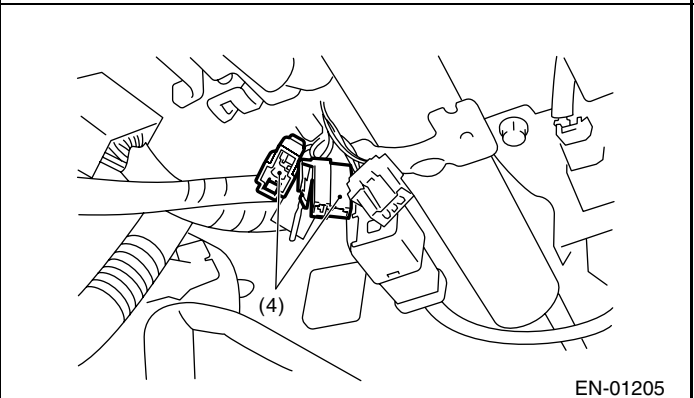

EN-01205



# ELECTRICAL COMPONENTS LOCATION

ENGINE (DIAGNOSTICS)

## • Sensor

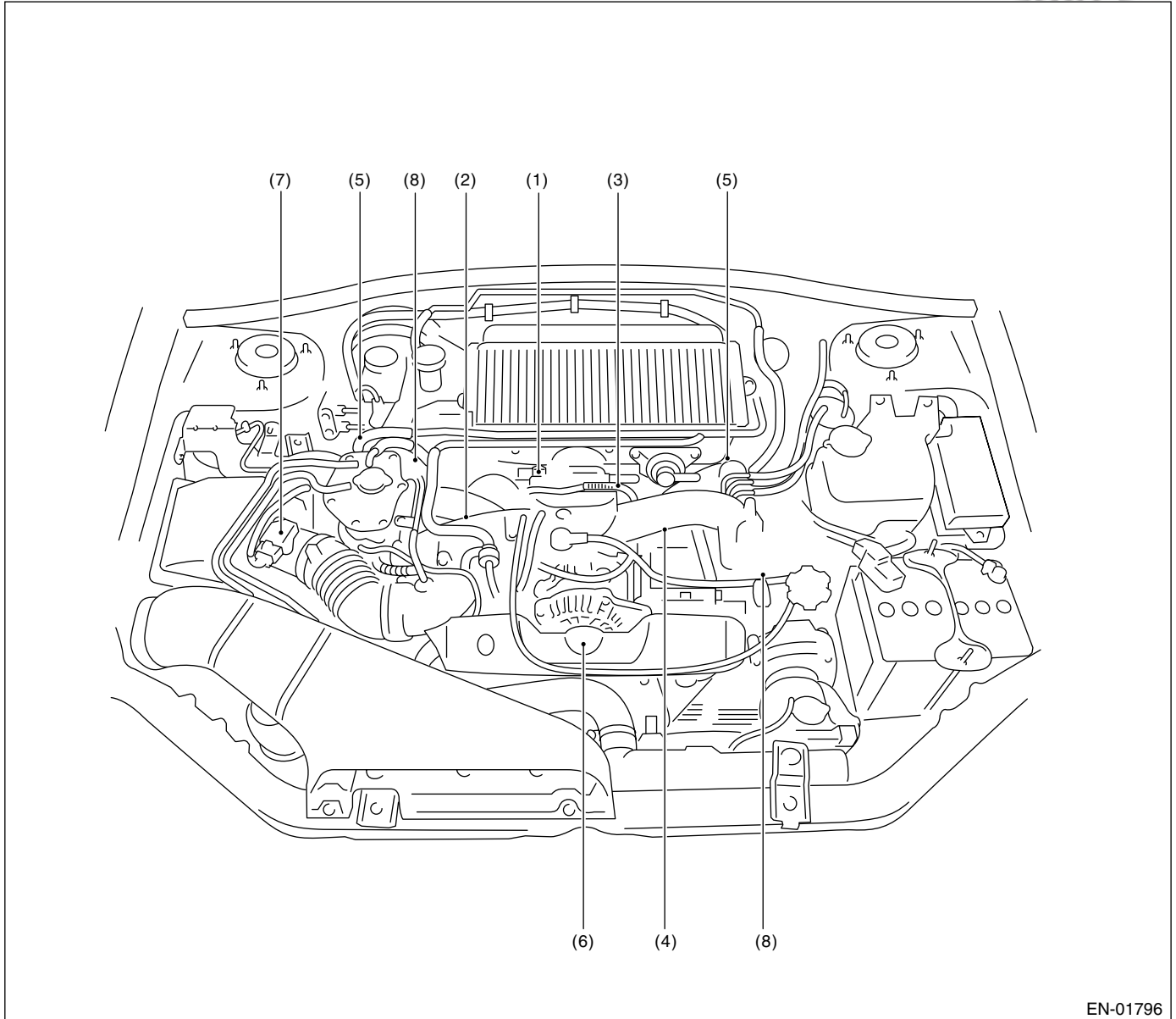

EN-01796

- |                                       |   |  |
|---------------------------------------|---|--|
| (1) Manifold absolute pressure sensor | (5) Camshaft position sensor                        | (8) Tumble generator valve position sensor |
| (2) Engine coolant temperature sensor | (6) Crankshaft position sensor                      |  |
| (3) Electric throttle                 | (7) Mass air flow and intake air temperature sensor |  |
| (4) Knock sensor                      |   |  |

# ELECTRICAL COMPONENTS LOCATION

## ENGINE (DIAGNOSTICS)

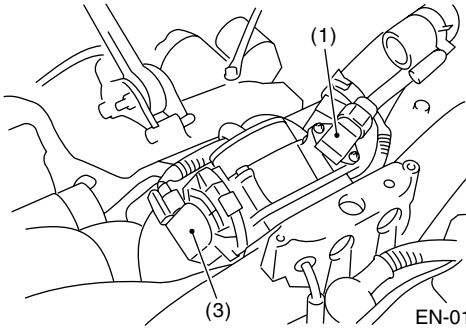

EN-01797

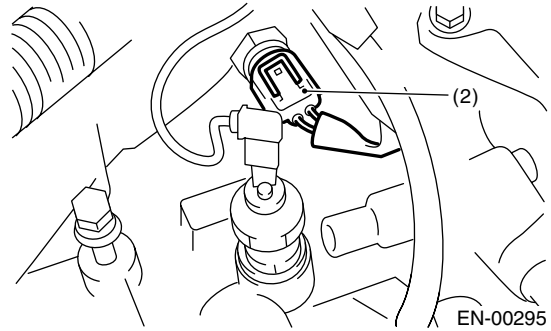

EN-00295

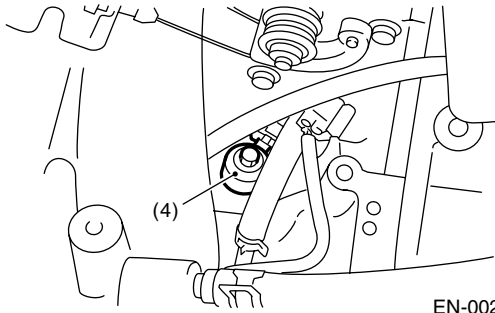

EN-00297

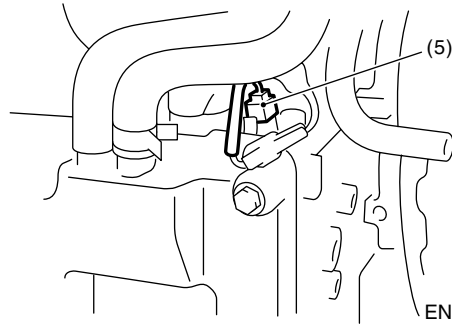

EN-01798

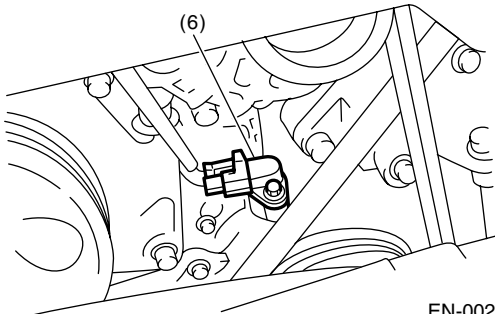

EN-00299

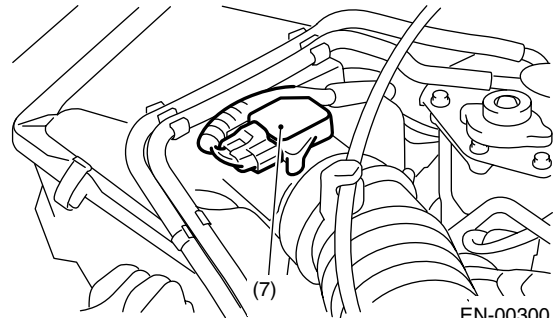

EN-00300

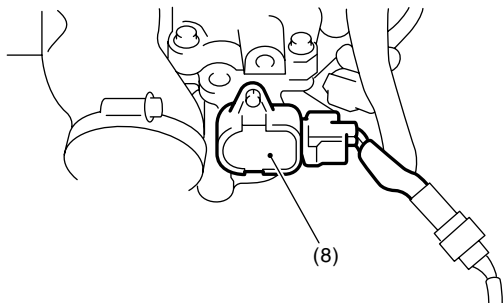

EN-00301

SUBARU.

# ELECTRICAL COMPONENTS LOCATION

ENGINE (DIAGNOSTICS)

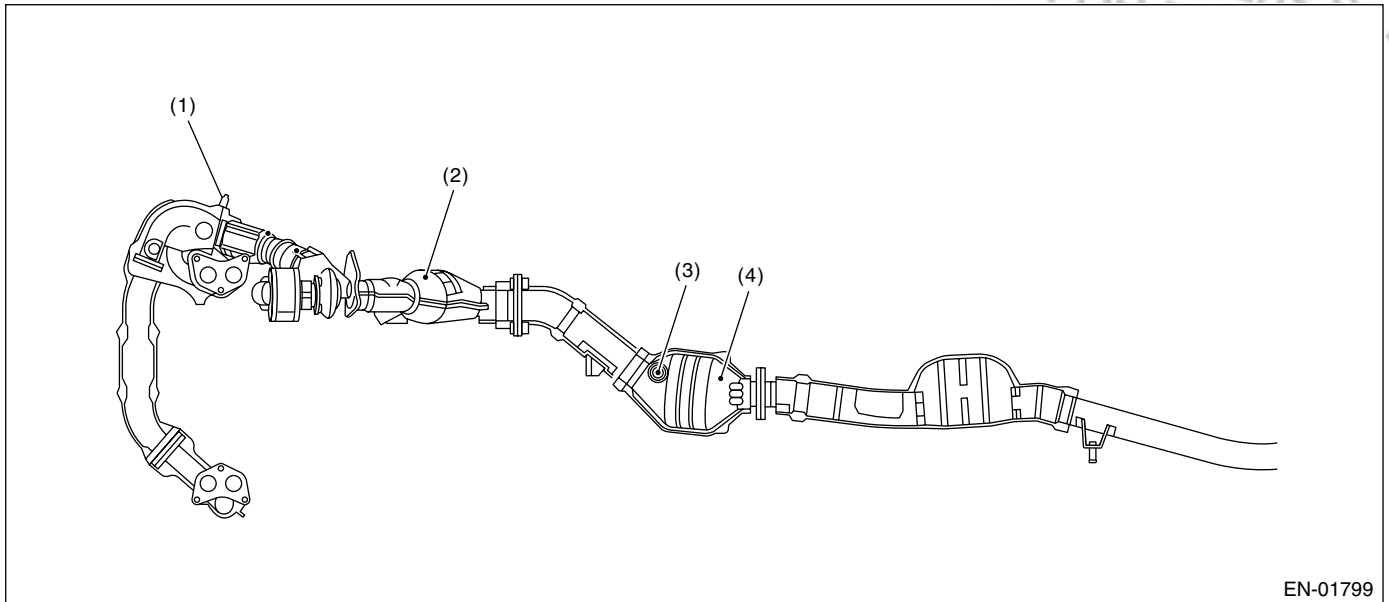

EN-01799

- (1) Front oxygen (A/F) sensor
- (2) Front catalytic converter

- (3) Rear oxygen sensor

- (4) Rear catalytic converter

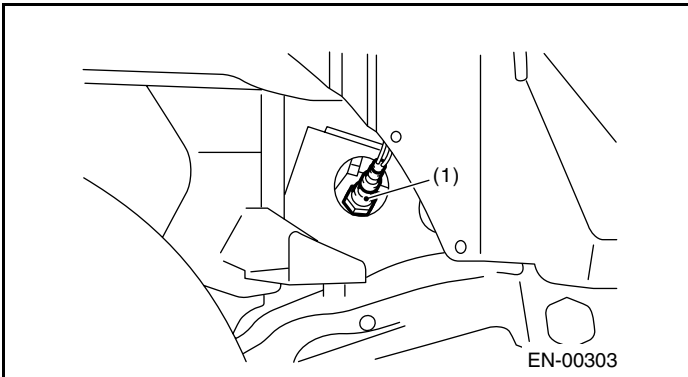

EN-00303

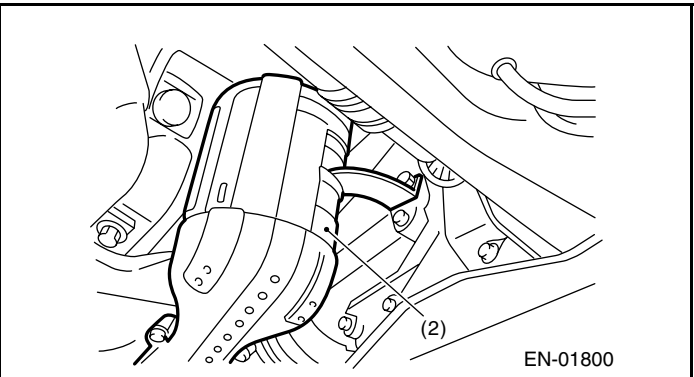

EN-01800

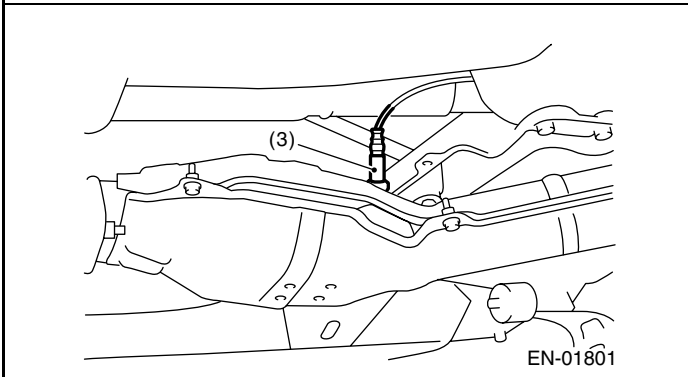

EN-01801

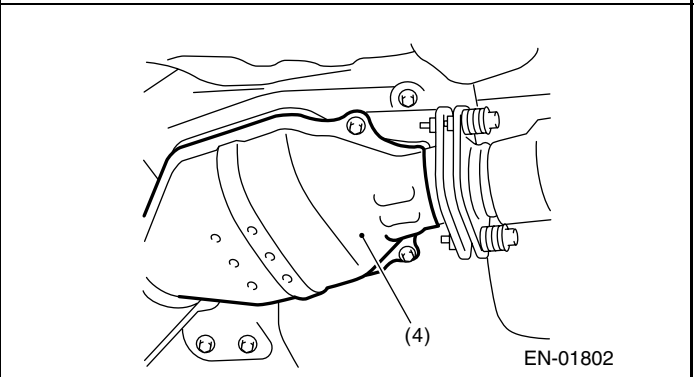

EN-01802

# ELECTRICAL COMPONENTS LOCATION

## ENGINE (DIAGNOSTICS)

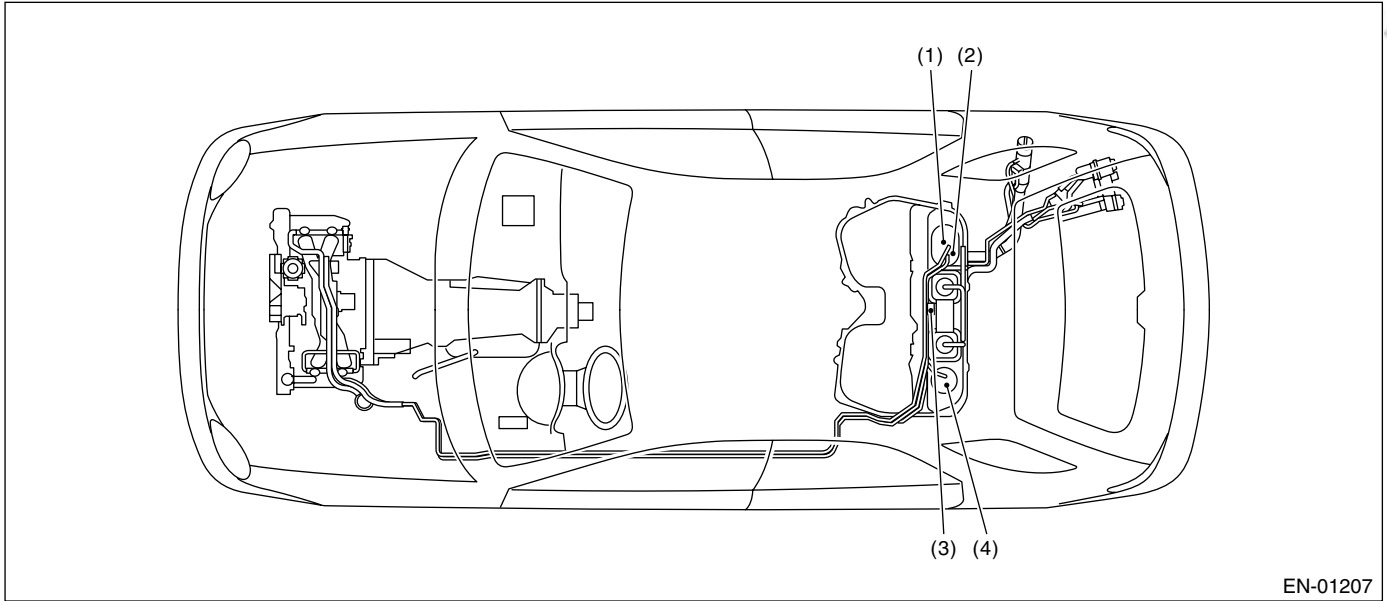

- (1) Fuel level sensor
- (2) Fuel temperature sensor

- (3) Fuel tank pressure sensor

- (4) Fuel sub level sensor

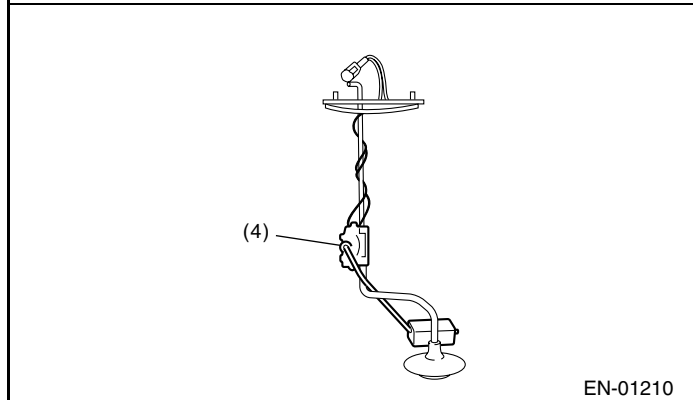
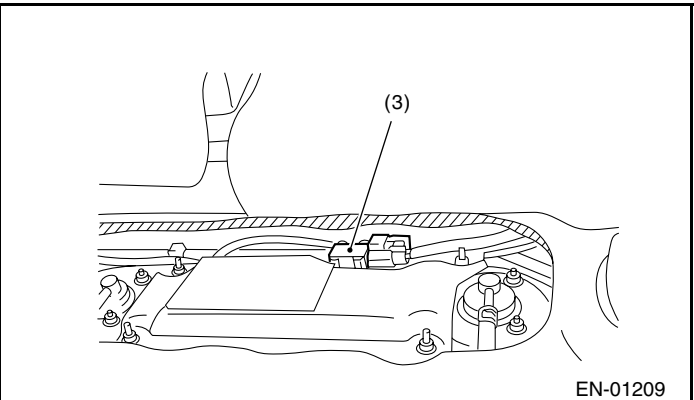
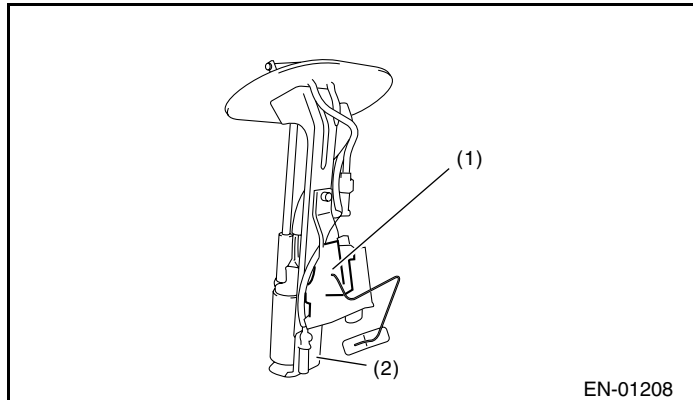

SUBARU.

# ELECTRICAL COMPONENTS LOCATION

ENGINE (DIAGNOSTICS)

## • Solenoid Valve, Actuator, Emission Control System Parts and Ignition System Parts

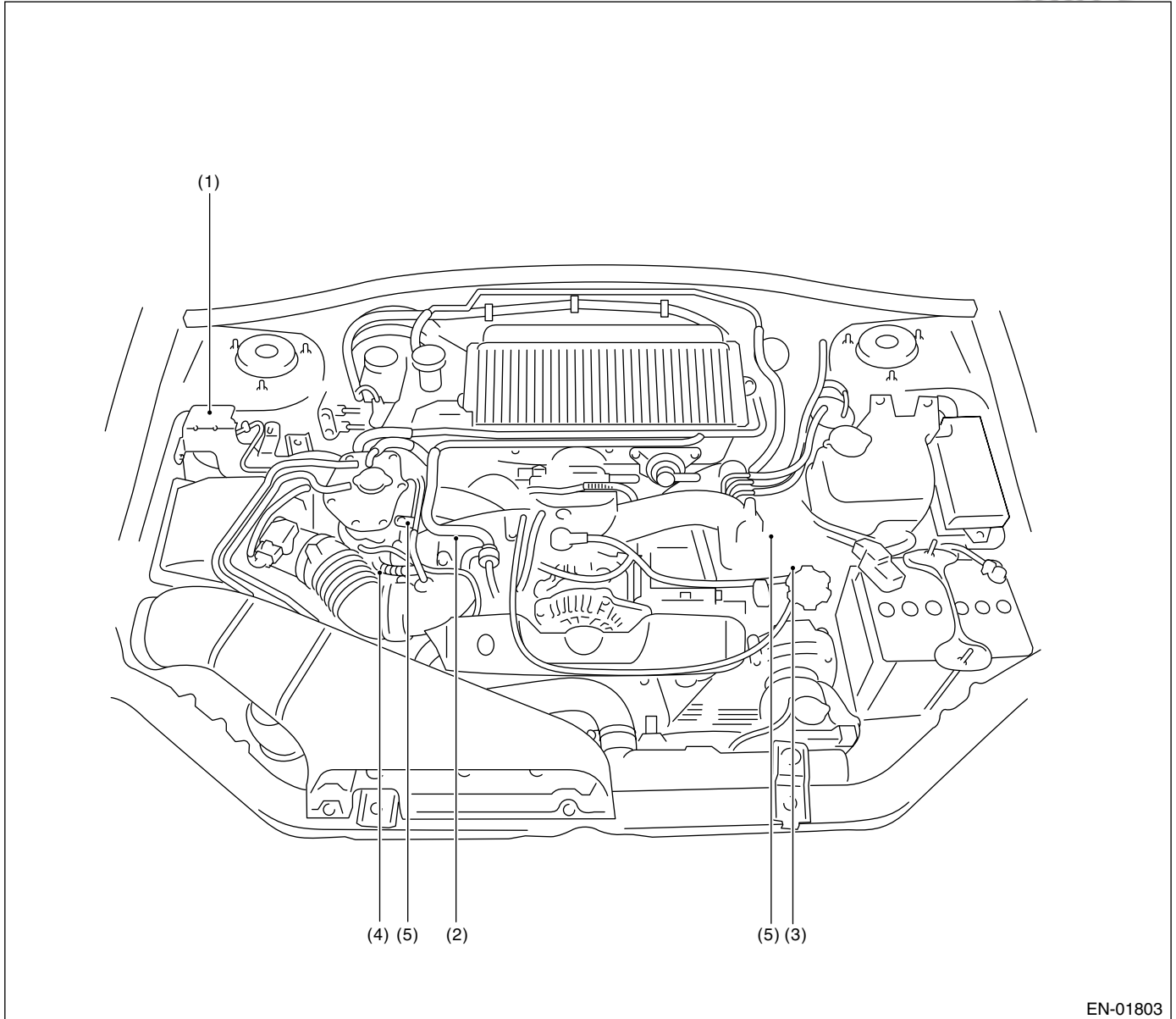

- (1) Wastegate control solenoid valve
- (2) Purge control solenoid valve

- (3) Ignition coil
- (4) Tumble generator valve actuator

- (5) Variable valve timing solenoid valve

# ELECTRICAL COMPONENTS LOCATION

## ENGINE (DIAGNOSTICS)

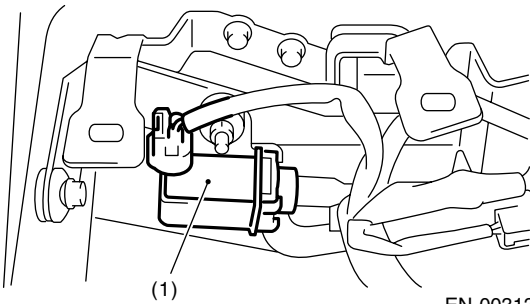

EN-00313

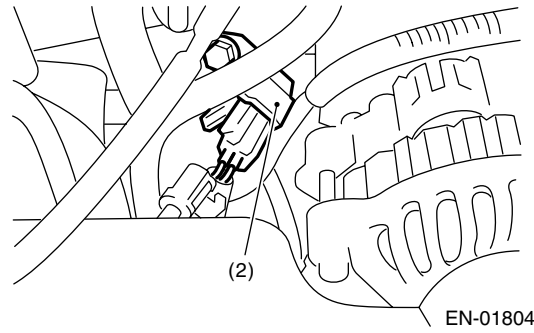

EN-01804

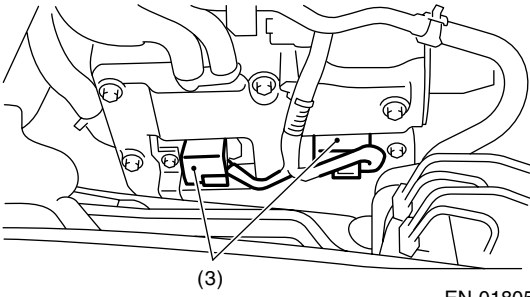

EN-01805

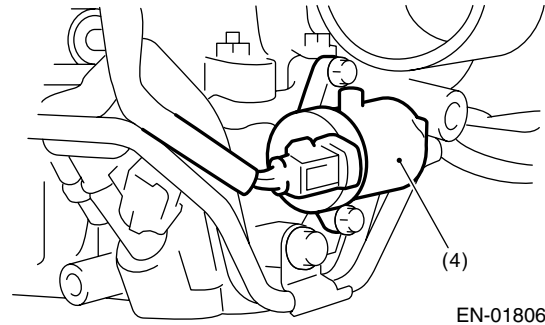

EN-01806

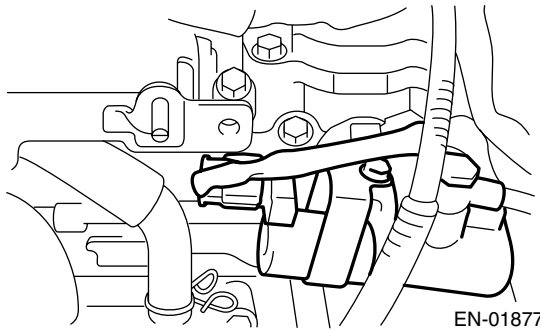

EN-01877

SUBARU.

# ELECTRICAL COMPONENTS LOCATION

ENGINE (DIAGNOSTICS)

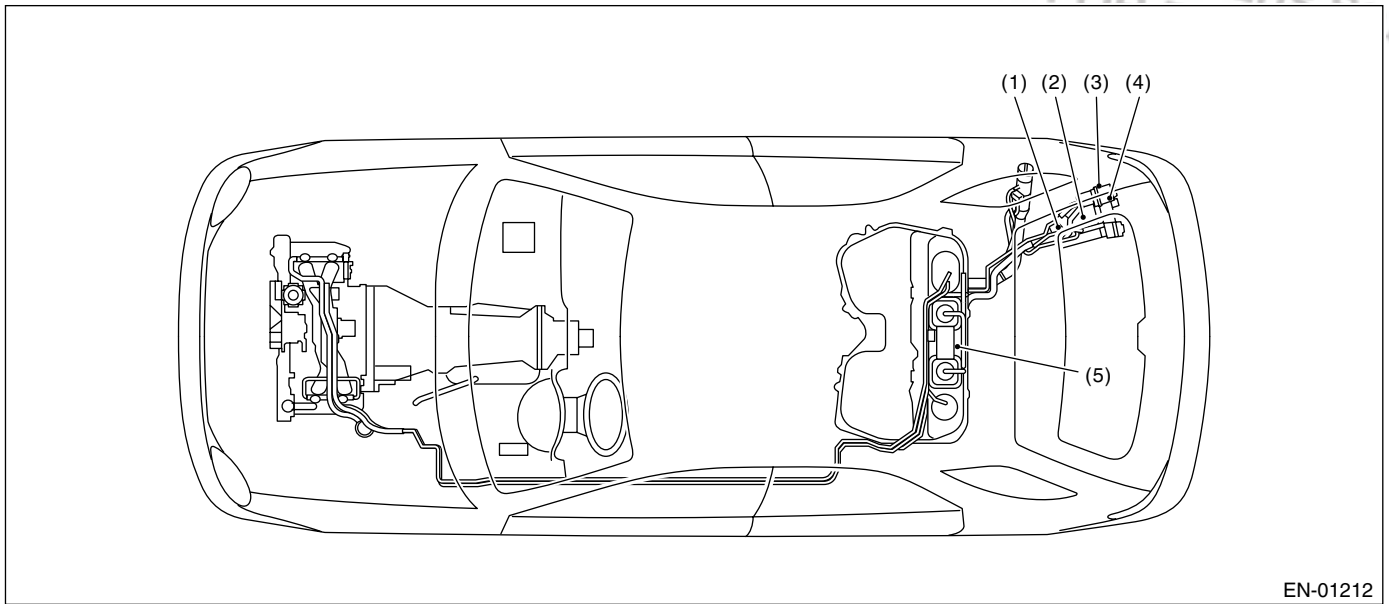

EN-01212

- (1) Pressure control solenoid valve
- (2) Canister
- (3) Drain valve
- (4) Drain filter
- (5) Fuel tank sensor control valve

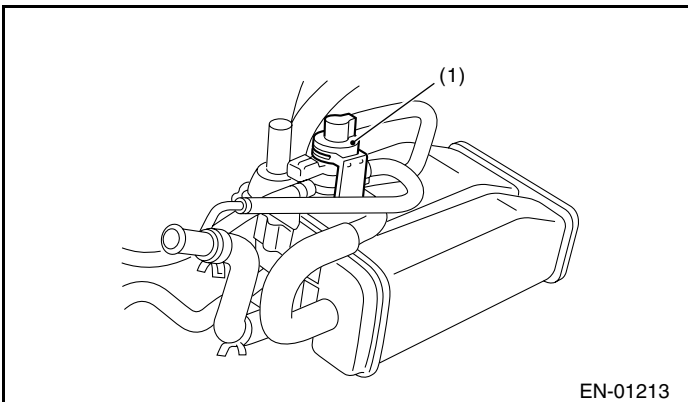

EN-01213

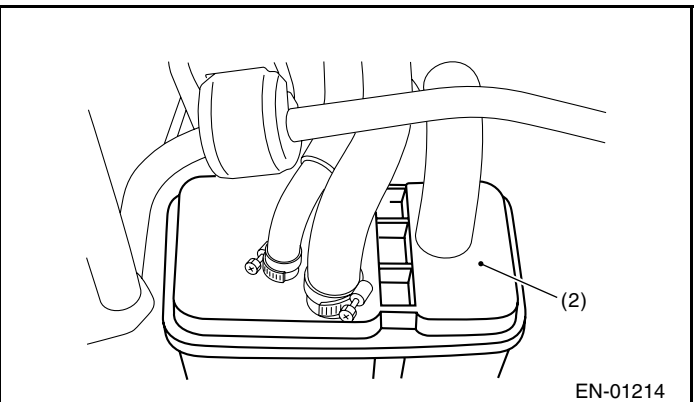

EN-01214

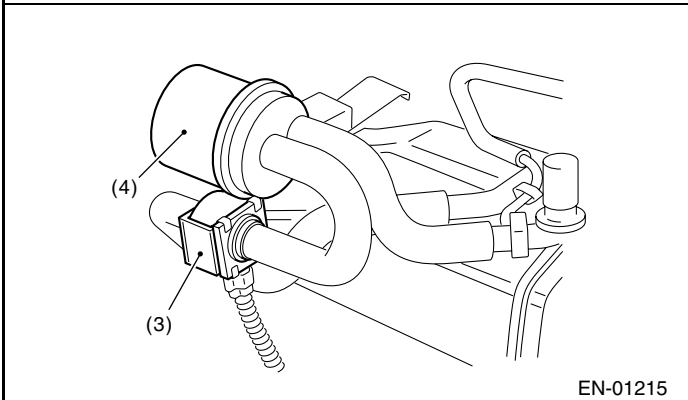

EN-01215

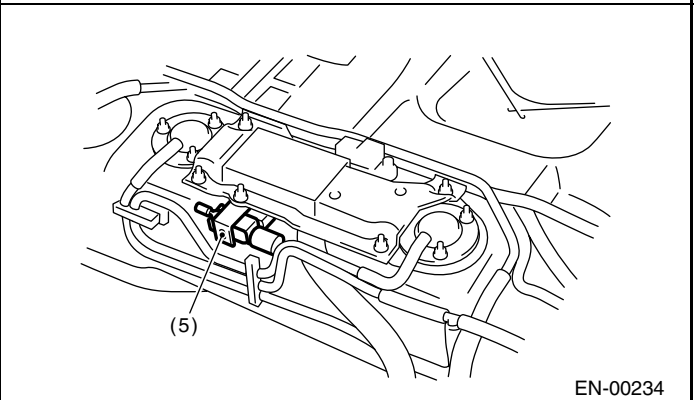

EN-00234

# ELECTRICAL COMPONENTS LOCATION

ENGINE (DIAGNOSTICS)

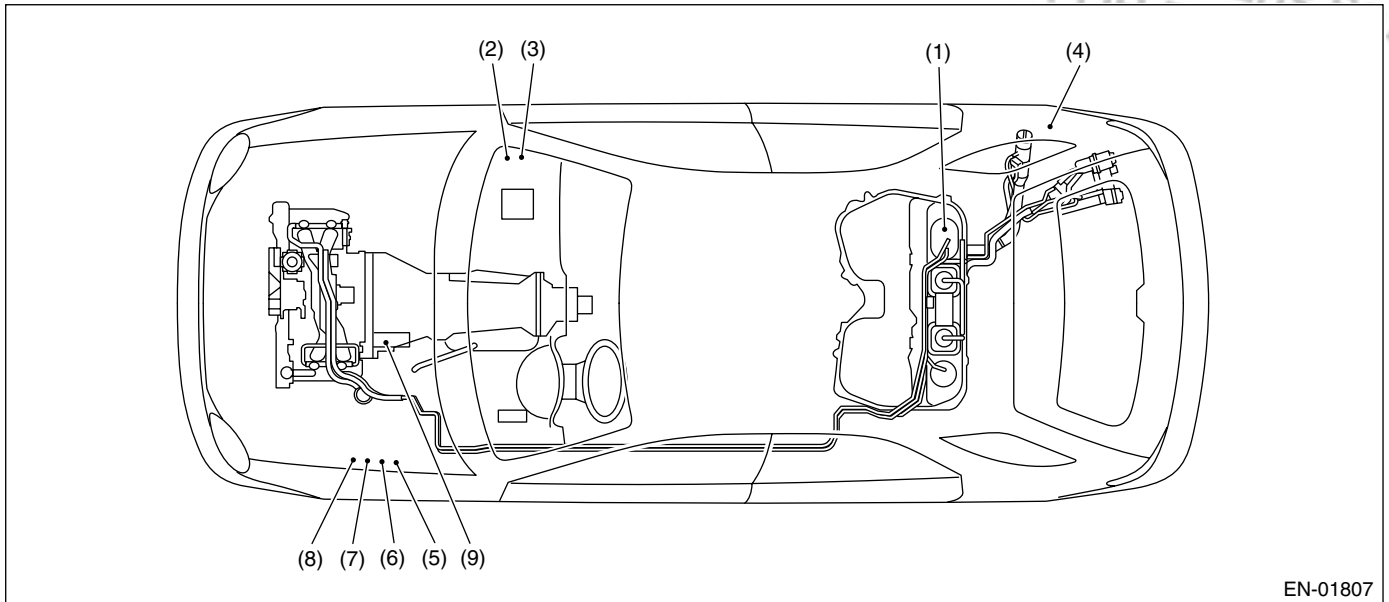

- |                     |                               |                              |
|---------------------|-------------------------------|------------------------------|
| (1) Fuel pump       | (4) Fuel pump control unit    | (7) Radiator sub fan relay 1 |
| (2) Main relay      | (5) Radiator main fan relay 1 | (8) Radiator sub fan relay 2 |
| (3) Fuel pump relay | (6) Radiator main fan relay 2 | (9) Starter                  |

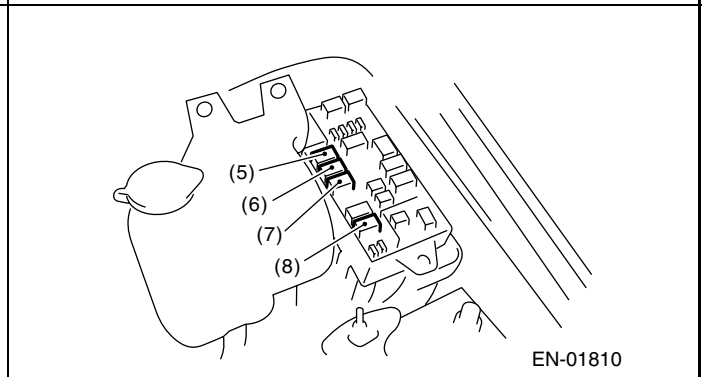
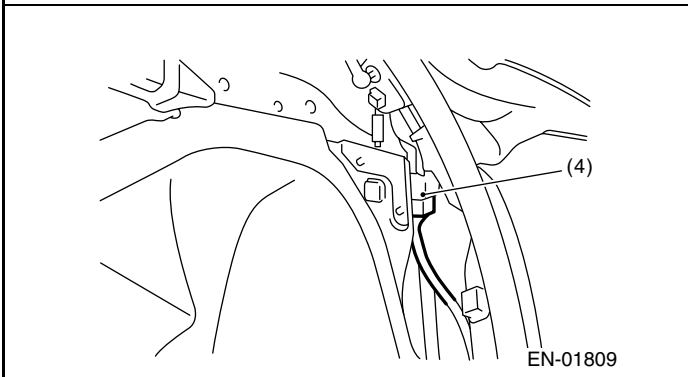
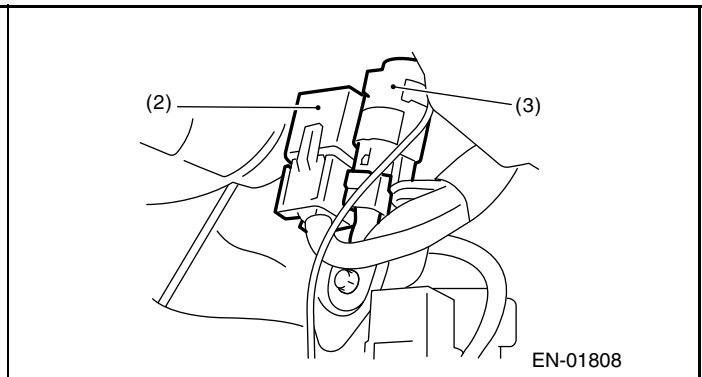
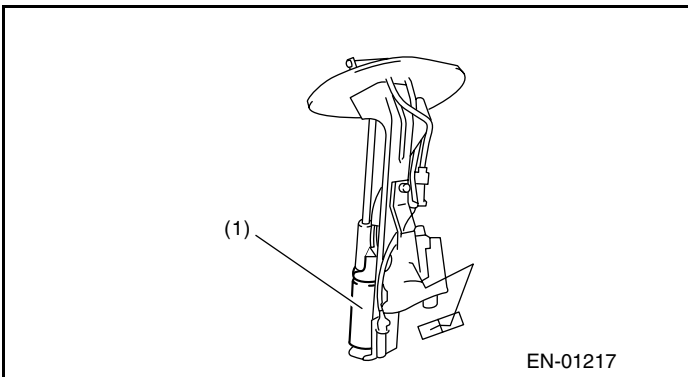



# ELECTRICAL COMPONENTS LOCATION

ENGINE (DIAGNOSTICS)

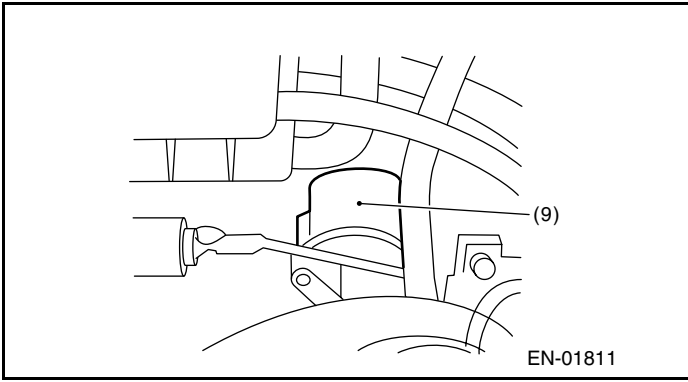

SUBARU.

## 2. TRANSMISSION

### • Solenoid Valve and Switch

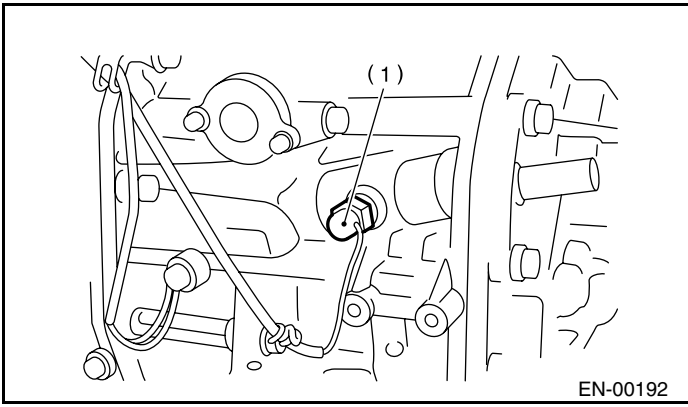

SUBARU.

(1) Neutral position switch

# ENGINE CONTROL MODULE (ECM) I/O SIGNAL

ENGINE (DIAGNOSTICS)

## 5. Engine Control Module (ECM) I/O Signal

### A: ELECTRICAL SPECIFICATION

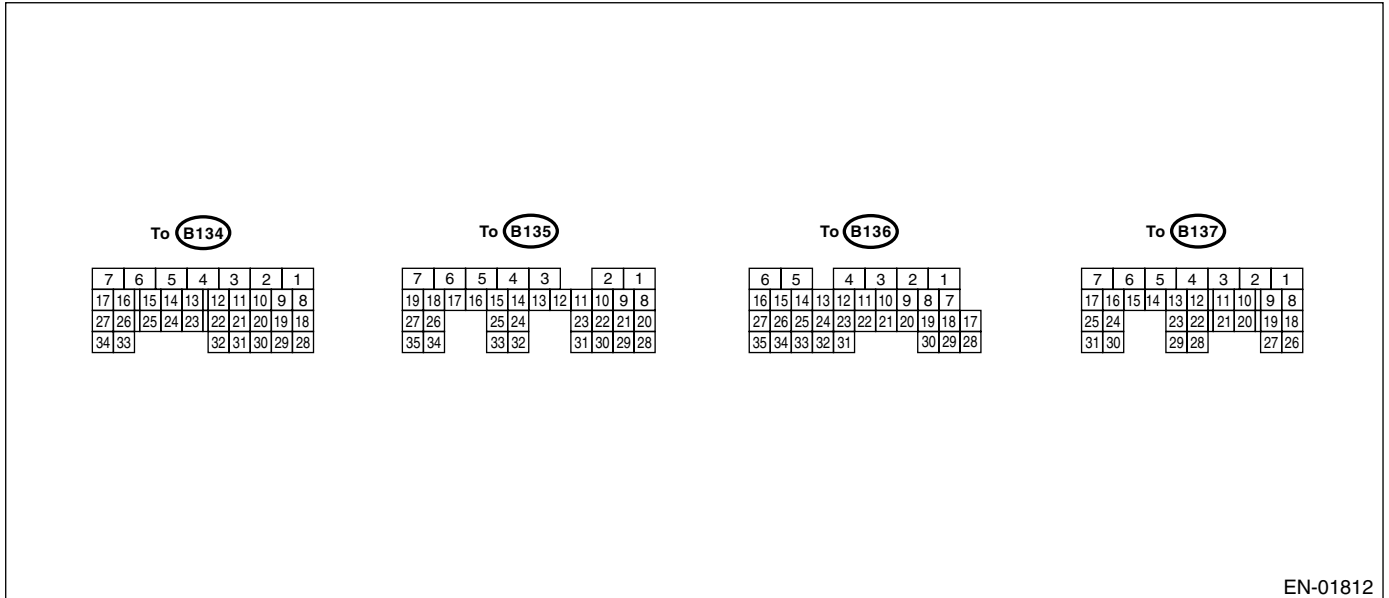

EN-01812

Content	Con- nector No.	Termi- nal No.	Signal (V)		Note	
			Ignition SW ON (Engine OFF)	Engine ON (Idling)		
Crank- shaft position sensor	Signal (+)	B135	10	0	-7 — +7	Sensor output waveform
	Signal (-)	B135	22	0	0	—
	Shield	B135	31	0	0	—
Rear oxy- gen sensor	Signal	B137	25	0	0 — 0.9	—
	Shield	B137	31	0	0	—
	GND (sen- sor)	B136	35	0	0	—
Front oxy- gen (A/F) sensor heater	Signal 1	B134	3	0 — 1.0	—	Sensor output waveform
	Signal 2	B134	2	0 — 1.0	—	Sensor output waveform
Rear oxygen sensor heater signal	B135	2	0 — 1.0	—	Sensor output waveform	
Engine coolant tempera- ture sen- sor	Signal	B136	14	1.0 — 1.4	1.0 — 1.4	After warm-up the engine.
	GND (sen- sor)	B136	35	0	0	After warm-up the engine.
Vehicle speed signal	B135	27	0 or 5	0 or 5	“5” and “0” are repeatedly dis- played when vehicle is driven.	
Mass air flow sen- sor	Signal	B136	23	—	0.3 — 4.5	—
	Shield	B136	32	0	0	—
	GND	B136	31	0	0	—
Intake air temperature sensor signal	B136	13	0.3 — 4.6	0.3 — 4.6	—	

# ENGINE CONTROL MODULE (ECM) I/O SIGNAL

ENGINE (DIAGNOSTICS)

Content		Connector No.	Terminal No.	Signal (V)		Note
				Ignition SW ON (Engine OFF)	Engine ON (Idling)	
Tumble generator valve position sensor RH	Signal	B136	27	Fully closed: 3.8 — 4.9 Fully opened: 0.2 — 0.9		—
	Power supply	B136	16	5	5	—
	GND (sensor)	B136	35	0	0	—
Tumble generator valve position sensor LH	Signal	B136	26	Fully closed: 3.8 — 4.9 Fully opened: 0.2 — 0.9		—
	Power supply	B136	16	5	5	—
	GND (sensor)	B136	35	0	0	—
Tumble generator valve RH (open)		B134	9	0 or 10 — 13	0 or 13 — 14	Sensor output waveform
Tumble generator valve RH (close)		B134	8	0 or 10 — 13	0 or 13 — 14	Sensor output waveform
Tumble generator valve LH (open)		B134	11	0 or 10 — 13	0 or 13 — 14	Sensor output waveform
Tumble generator valve LH (close)		B134	10	0 or 10 — 13	0 or 13 — 14	Sensor output waveform
Wastegate control solenoid valve		B134	32	0 or 10 — 13	0 or 13 — 14	Sensor output waveform
Starter switch		B137	8	0	0	Cranking: 8 — 14
A/C switch		B137	16	ON: 10 — 13 OFF: 0	ON: 13 — 14 OFF: 0	—
Ignition switch		B137	15	10 — 13	13 — 14	—
Neutral position switch		B137	9	ON: 10 — 13 OFF: 0	ON: 13 — 14 OFF: 0	—
Test mode connector		B137	14	5	5	When connected: 0
Knock sensor	Signal	B136	25	2.8	2.8	—
	Shield	B136	33	0	0	—
Back-up power supply		B135	19	10 — 13	13 — 14	Ignition switch "OFF": 10 — 13
Control unit power supply		B135	5	10 — 13	13 — 14	—
		B135	6	10 — 13	13 — 14	—
Sensor power supply		B136	16	5	5	—
Ignition control	#1	B135	18	0	13 — 14	Waveform
	#2	B135	17	0	13 — 14	Waveform
	#3	B135	16	0	13 — 14	Waveform
	#4	B135	16	0	13 — 14	Waveform
Fuel injector	#1	B136	6	10 — 13	1 — 14	Waveform
	#2	B136	5	10 — 13	1 — 14	Waveform
	#3	B136	4	10 — 13	1 — 14	Waveform
	#4	B136	3	10 — 13	1 — 14	Waveform
Fuel pump control unit	Signal 1	B135	26	0 or 5	0 or 5	Sensor output waveform
	Signal 2	B137	28	10 — 13	13 — 14	—
A/C relay control		B133	33	ON: 0.5 or less OFF: 10 — 13	ON: 0.5 or less OFF: 13 — 14	—
Radiator fan relay 1 control		B135	25	ON: 0.5 or less OFF: 10 — 13	ON: 0.5 or less OFF: 13 — 14	—
Radiator fan relay 2 control		B135	24	ON: 0.5 or less OFF: 10 — 13	ON: 0.5 or less OFF: 13 — 14	Model with A/C only

# ENGINE CONTROL MODULE (ECM) I/O SIGNAL

## ENGINE (DIAGNOSTICS)

Content	Con- nector No.	Termi- nal No.	Signal (V)		Note	
			Ignition SW ON (Engine OFF)	Engine ON (Idling)		
Malfunction indicator lamp	B134	17	—	—	Light "ON": 1 or less Light "OFF": 10 — 14	
Engine speed output	B134	23	—	0 — 13 or more	Waveform	
Purge control solenoid valve	B134	14	ON: 1 or less OFF: 10 — 13	ON: 1 or less OFF: 13 — 14	Sensor output waveform	
Manifold absolute pressure sensor	Signal	B136	22	1.7 — 2.4	1.1 — 1.6	—
	Power supply	B136	16	5	5	
	GND (sensor)	B136	35	0	0	
Fuel tank pressure sensor	Signal	B136	21	2.3 — 2.7	2.3 — 2.7	The valve operates when fuel filler cap is removed and reinstalled.
	GND (sensor)	B136	35	0	0	—
Fuel tank pressure control solenoid valve	B134	12	ON: 1 or less OFF: 10 — 13	ON: 1 or less OFF: 13 — 14	—	
Drain valve	B134	13	ON: 1 or less OFF: 10 — 13	ON: 1 or less OFF: 13 — 14	—	
Fuel tank sensor control valve	B134	24	ON: 1 or less OFF: 10 — 13	ON: 1 or less OFF: 13 — 14	—	
Fuel level sensor	B136	20	0.12 — 4.75	0.12 — 4.75	—	
Fuel temperature sensor signal	B136	12	2.5 — 3.8	2.5 — 3.8	Ambient temperature: 25°C (75°F)	
Blow-by leak diagnosis signal	B137	24	0	0	When disconnection (malfunction): 5	
Small light switch	B137	12	ON: 0 OFF: 10 — 13	ON: 0 OFF: 13 — 14	—	
Blower fan switch	B137	13	ON: 0 OFF: 10 — 13	ON: 0 OFF: 13 — 14	—	
Rear defogger switch	B137	11	ON: 0 OFF: 10 — 13	ON: 0 OFF: 13 — 14	—	
Power steering oil pressure switch	B137	10	10 — 13	ON: 0 OFF: 13 — 14	—	
Front oxygen (A/F) sensor signal (+)	B134	33	2.8 — 3.2	2.8 — 3.2	—	
Front oxygen (A/F) sensor signal (-)	B134	26	2.4 — 2.7	2.4 — 2.7	—	
Front oxygen (A/F) sensor shield	B134	25	0	0	—	
SSM/GST communication line	B137	20	Less than 1 ←→ More than 4	Less than 1 ←→ More than 4	—	
GND (injectors)	B137	7	0	0	—	
GND (ignition system)	B135	12	0	0	—	
GND (power supply)	B135	4	0	0	—	
	B135	1	0	0	—	
GND (control systems)	B137	1	0	0	—	
	B137	2	0	0	—	
GND (front oxygen (A/F) sensor heater 1)	B134	7	0	0	—	
GND (front oxygen (A/F) sensor heater 2)	B134	6	0	0	—	

# ENGINE CONTROL MODULE (ECM) I/O SIGNAL

ENGINE (DIAGNOSTICS)

Content	Con- nector No.	Termi- nal No.	Signal (V)		Note	
			Ignition SW ON (Engine OFF)	Engine ON (Idling)		
Camshaft position sen- sor (LH)	B135	8	0 — 0.9	ON: 0 OFF: 4.7 — 5.3	Sensor output waveform	
Camshaft position sen- sor (RH)	B135	9	0 — 0.9	ON: 0 OFF: 4.7 — 5.3	Sensor output waveform	
Electric throttle	Main	B136	0.64 — 0.72 Fully opened: 3.96	0.64 — 0.72 (After engine warm-up)	Fully closed: 0.6 Fully opened: 3.96	
	Sub	B136	1.51 — 1.58 Fully opened: 4.17	1.51 — 1.58 (After engine warm-up)	Fully closed: 1.48 Fully opened: 4.17	
	Power supply	B136	5	5	—	
	GND (sen- sor)	B137	3	0	0	—
Electric throttle motor (+)	B137	5	Duty waveform	Duty waveform	Driving frequency: 500Hz	
Electric throttle motor (-)	B137	4	Duty waveform	Duty waveform	Driving frequency: 500Hz	
Electric throttle motor power supply	B137	6	10 — 13	13 — 14	—	
Electric throttle motor relay	B135	35	ON: 0 OFF: 10 — 13	ON: 0 OFF: 13 — 14	When ignition switch is ON: ON	
Variable valve tim- ing sole- noid valve (LH)	Signal (+)	B134	19	ON: 10 — 13 OFF: 0	ON: 13 — 14 OFF: 0	—
	Signal (-)	B134	29	0	0	—
Variable valve tim- ing sole- noid valve (RH)	Signal (+)	B134	18	ON: 10 — 13 OFF: 0	ON: 13 — 14 OFF: 0	—
	Signal (-)	B134	28	0	0	—
Accelera- tor position sensor	Main	B136	17	Fully closed: 1 Fully opened: 3.5	Fully closed: 1 Fully opened: 3.5	—
	Power supply	B136	15	5	5	—
	GND (sen- sor)	B136	34	0	0	—
	Sub	B136	28	Fully closed: 1 Fully opened: 3.5	Fully closed: 1 Fully opened: 3.5	—
Cruise control set light	B134	16	ON: 0 OFF: 10 — 13	ON: 0 OFF: 13 — 14	—	
Main light	B134	15	ON: 0 OFF: 10 — 13	ON: 0 OFF: 13 — 14	—	
Clutch switch	B134	1	When clutch pedal is depressed: 0 When clutch pedal is released: 10 — 13	When clutch pedal is depressed: 0 When clutch pedal is released: 13 — 14	—	
SET/COAST switch	B136	11	ON: 10 — 13 OFF: 0	ON: 13 — 14 OFF: 0	—	
Brake switch 1	B136	9	When brake pedal is depressed: 0 When brake pedal is released: 10 — 13	When brake pedal is depressed: 0 When brake pedal is released: 13 — 14	—	

# ENGINE CONTROL MODULE (ECM) I/O SIGNAL

## ENGINE (DIAGNOSTICS)

Content	Con- nector No.	Termi- nal No.	Signal (V)		Note
			Ignition SW ON (Engine OFF)	Engine ON (Idling)	
Brake switch 2	B136	8	When brake pedal is depressed: 10 — 13 When brake pedal is released: 0	When brake pedal is depressed: 13 — 14 When brake pedal is released: 0	—
RESUME/ACCEL switch	B136	10	ON: 10 — 13 OFF: 0	ON: 13 — 14 OFF: 0	—
Main switch	B136	7	ON: 10 — 13 OFF: 0	ON: 13 — 14 OFF: 0	—

## 6. Engine Condition Data

### A: ELECTRICAL SPECIFICATION

Content	Specified data
Engine load	1.2 — 2.9 (%): Idling
	4.7 — 12.8 (%): 2,500 rpm racing

Measuring condition:

- After warm-up the engine.
- Gear position is in neutral position.
- A/C is turned to OFF.
- All accessory switches are turned to OFF.

# DATA LINK CONNECTOR

ENGINE (DIAGNOSTICS)

## 7. Data Link Connector

### A: NOTE

This connector is used both for the OBD-II general scan tools and Subaru Select Monitor.

### CAUTION:

Do not connect any scan tools other than the OBD-II general scan tools and Subaru Select Monitor, because the circuit for Subaru Select Monitor may be damaged.

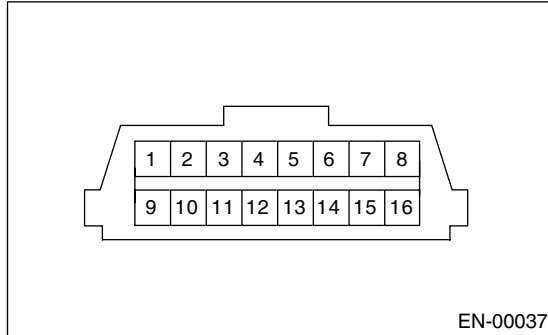

Terminal No.	Contents	Terminal No.	Contents
1	Power supply	9	Blank
2	Blank	10	Subaru Select Monitor/OBD-II general scan tool signal
3	Blank	11	Blank
4	Blank	12	Ground
5	Blank	13	Ground
6	Line end check signal 1	14	Blank
7	Blank	15	Blank
8	Line end check signal 2	16	Blank



## 8. OBD-II General Scan Tool

### A: OPERATION

#### 1. HOW TO USE OBD-II GENERAL SCAN TOOL

- 1) Prepare a general scan tool (OBD-II general scan tool) required by SAE J1978.
- 2) Open the cover and connect the OBD-II general scan tool to data link connector located in the lower portion of instrument panel (on the driver's side).

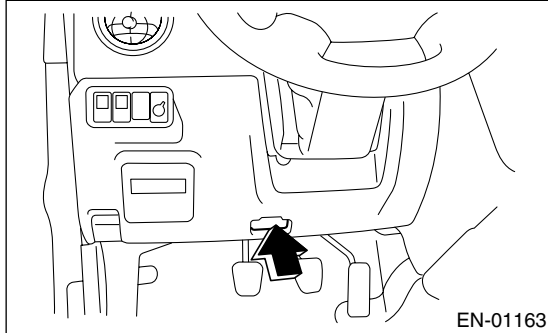

- 3) Using the OBD-II general scan tool, call up DTC and freeze frame data.

OBD-II general scan tool functions consist of:

- (1) MODE \$01: Current powertrain diagnostic data
- (2) MODE \$02: Powertrain freeze frame data
- (3) MODE \$03: Emission-related powertrain DTC
- (4) MODE \$04: Clear/Reset emission-related diagnostic information
- (5) MODE \$06: Request on-board monitoring test results for non-continuously monitored systems
- (6) MODE \$07: Request on-board monitoring test results for continuously monitored systems
- (7) MODE \$09: Request vehicle information

Read out the data according to repair procedures. (For detailed operation procedures, refer to the OBD-II General Scan Tool Operation Manual.)

**NOTE:**

For details concerning DTC, refer to the List of Diagnostic Trouble Code (DTC). <Ref. to EN(STi)-66, List of Diagnostic Trouble Code (DTC).>

#### 2. MODE \$01 (CURRENT POWERTRAIN DIAGNOSTIC DATA)

Refers to data denoting the current operating condition of analog input/output, digital input/output and/or the powertrain system.

A list of the support data and PID (Parameter Identification) codes are shown in the following table.

PID	Data	Unit of measure
01	Number of emission-related powertrain DTC and malfunction indicator light status and diagnosis support information	—
03	Fuel system control status	—
04	Calculated engine load value	%
05	Engine coolant temperature	°C
06	Short term fuel trim	%
07	Long term fuel trim	%
0B	Intake manifold absolute pressure	kPa
0C	Engine revolution	rpm
0D	Vehicle speed	km/h
0E	Ignition timing advance	°
0F	Intake air temperature	°C
10	Air flow rate from mass air flow sensor	g/sec
11	Throttle valve absolute opening angle	%
13	Check whether oxygen sensor is installed.	—
15	Oxygen sensor output voltage and short term fuel trim associated with oxygen sensor	V and %
1C	Supporting OBD system	—
24	A/F value and A/F sensor output voltage	— and V
34	A/F value and A/F sensor current	— and mA

**NOTE:**

Refer to OBD-II general scan tool manufacturer's instruction manual to access generic OBD-II PIDs (MODE \$01).

# OBD-II GENERAL SCAN TOOL

## ENGINE (DIAGNOSTICS)

### 3. MODE \$02 (POWERTRAIN FREEZE FRAME DATA)

Refers to data denoting the operating condition when trouble is sensed by the on-board diagnosis system. A list of the support data and PID (Parameter Identification) codes are shown in the following table.

PID	Data	Unit of measure
02	DTC that caused CARB required freeze frame data storage	—
03	Fuel system control status	—
04	Calculated engine load value	%
05	Engine coolant temperature	°C
06	Short term fuel trim	%
07	Long term fuel trim	%
0B	Intake manifold absolute pressure	mmHg
0C	Engine revolution	rpm
0D	Vehicle speed	km/h
0E	Ignition timing advance	°
0F	Intake air temperature	°C
10	Air flow rate from mass air flow sensor	g/sec
11	Throttle valve opening angle	%
15	O <sub>2</sub> sensor output voltage and O <sub>2</sub> sensor short term fuel trim	V and %

**NOTE:**

Refer to OBD-II general scan tool manufacturer's instruction manual to access freeze frame data (MODE \$02).

### 4. MODE \$03 (EMISSION-RELATED POWERTRAIN DIAGNOSTIC TROUBLE CODE (DTC))

Refer to Read Diagnostic Trouble Code (DTC) for information about data denoting emission-related powertrain DTC. <Ref. to EN(STi)-34, Read Diagnostic Trouble Code (DTC).>

### 5. MODE \$04 (CLEAR/RESET EMISSION-RELATED DIAGNOSTIC INFORMATION)

Refers to the mode used to clear or reset emission-related diagnostic information (OBD-II trouble diagnostic information).

**NOTE:**

Refer to OBD-II general scan tool manufacturer's instruction manual to clear or reset emission-related diagnostic information (MODE \$04).

### 6. MODE \$06

Refer to test value of troubleshooting and data of test limit on support data bit sequence table. List of support data is shown in the following table.

TID	CID	Test value & Test limit
\$01	\$01	Catalyst system efficiency below threshold
\$03	\$01	Evaporative emission control system large leak
	\$02	Evaporative emission control system small leak
	\$03	Evaporative emission control system very small leak
\$05	\$01	O <sub>2</sub> sensor circuit slow response (Bank 1 Sensor 1)
\$06	\$01	O <sub>2</sub> sensor circuit (Bank 1 Sensor 2)
	\$02	
\$07	\$01	O <sub>2</sub> sensor circuit slow response (Bank 1 Sensor 2)
\$0C	\$01	Coolant thermostat (Coolant temperature below thermostat regulating temperature)
\$0F	\$01	Drain valve range/performance
	\$02	

### 7. MODE \$07

Refer to data of DTC (pending code) for troubleshooting result about emission in first time.

**8. MODE \$09**

Refer to data of vehicle specification (VIN, calibration ID, etc.).

## 9. Subaru Select Monitor

### A: OPERATION

#### 1. HOW TO USE SUBARU SELECT MONITOR

1) Prepare the Subaru Select Monitor kit. <Ref. to EN(STi)-7, PREPARATION TOOL, General Description.>

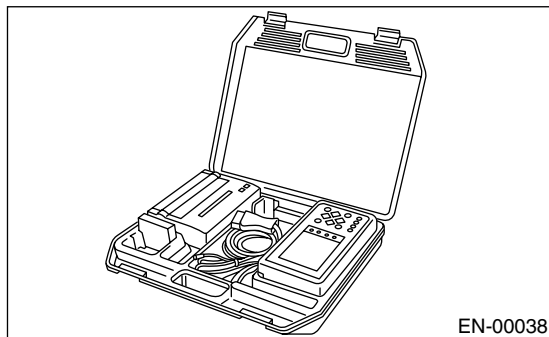

2) Connect the diagnosis cable to Subaru Select Monitor.

3) Insert the cartridge into Subaru Select Monitor. <Ref. to EN(STi)-7, PREPARATION TOOL, General Description.>

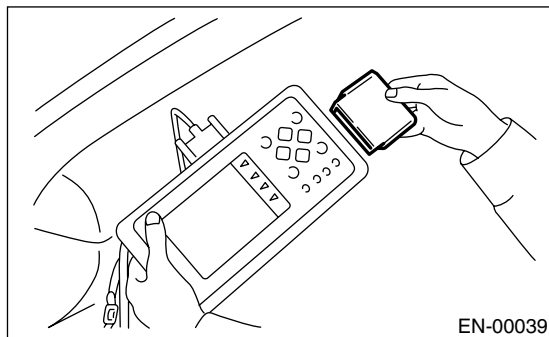

4) Connect the Subaru Select Monitor to data link connector.

(1) Data link connector is located in the lower portion of instrument panel (on the driver's side).

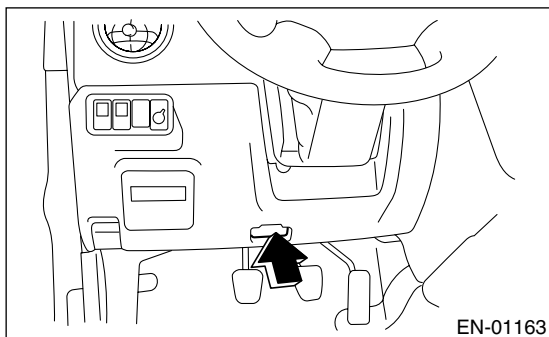

(2) Connect the diagnosis cable to data link connector.

#### CAUTION:

**Do not connect the scan tools except for Subaru Select Monitor and OBD-II general scan tool.**

5) Turn the ignition switch to ON (engine OFF) and Subaru Select Monitor switch to ON.

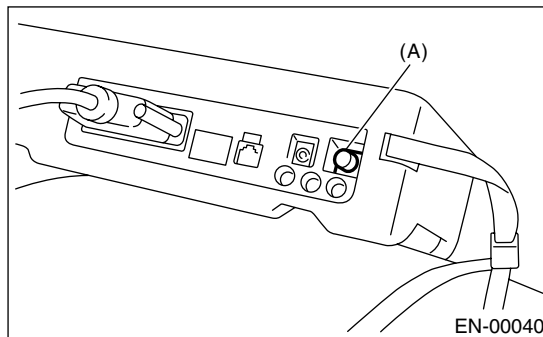

(A) Power switch

6) Using the Subaru Select Monitor, call up the DTC and various data, and then record them.

#### 2. READ DIAGNOSTIC TROUBLE CODE (DTC) FOR ENGINE. (NORMAL MODE)

Refer to Read Diagnostic Trouble Code (DTC) for information about how to indicate DTC. <Ref. to EN(STi)-34, Read Diagnostic Trouble Code (DTC).>

#### 3. READ DIAGNOSTIC TROUBLE CODE (DTC) FOR ENGINE. (OBD MODE)

Refer to Read Diagnostic Trouble Code (DTC) for information about how to indicate DTC. <Ref. to EN(STi)-34, Read Diagnostic Trouble Code (DTC).>

#### 4. READ CURRENT DATA FOR ENGINE. (NORMAL MODE)

1) On the «Main Menu» display screen, select the {Each System Check} and press the [YES] key.

2) On the «System Selection Menu» display screen, select the {Engine Control System} and press the [YES] key.

3) Press the [YES] key after the information of engine type is displayed.

4) On the «Engine Diagnosis» display screen, select the {Current Data Display & Save} and press the [YES] key.

5) On the «Data Display Menu» display screen, select the {Data Display} and press the [YES] key.

# SUBARU SELECT MONITOR

ENGINE (DIAGNOSTICS)

6) Using the scroll key, move the display screen up or down until desired data is shown.

- A list of the support data is shown in the following table.

Contents	Display	Unit of measure
Battery voltage	Battery Voltage	V
Vehicle speed signal	Vehicle Speed	km/h or MPH
Engine speed signal	Engine Speed	rpm
Engine coolant temperature signal	Coolant Temp.	°C or °F
Ignition timing signal	Ignition Timing	deg
Throttle position signal	Throttle Opening Angle	%
Injection pulse width	Fuel Injection #1 Pulse	ms
Fuel pump duty control signal	Fuel Pump Duty	%
A/F sensor current	A/F Sensor #1 Current	mA
A/F sensor resistance	A/F Sensor #1 Resistance	ohm
Front oxygen (A/F) sensor lambda value	A/F Sensor #1	—
Rear oxygen sensor output signal	Rear O <sub>2</sub> Sensor	V
Short term fuel trim	A/F Correction #1	%
Knock sensor correction	Knocking Correction	deg
Atmospheric absolute pressure signal	Atmosphere Pressure	mmHg or kPa or inHg or psi
Intake manifold relative pressure signal	Mani. Relative Pressure	mmHg or kPa or inHg or psi
Intake manifold absolute pressure signal	Mani. Absolute Pressure	mmHg or kPa or inHg or psi
A/F correction (short term fuel trim) by rear oxygen sensor	A/F Correction #3	%
Long term whole fuel trim	A/F Learning #1	%
Canister purge control solenoid valve duty ratio	CPC Valve Duty Ratio	%
Primary supercharged pressure control signal	Primary Control	%
Tumble generator valve position sensor signal (right side)	TGV Position Sensor R	V
Tumble generator valve position sensor signal (left side)	TGV Position Sensor L	V
Accelerator position	Accel. Opening Angle	%
VVT advanced timing (R)	VVTAdv.Amount R	deg
VVT advanced timing (L)	VVTAdv.Amount L	deg
OCV duty ratio (R)	OCV Duty R	%
OCV duty ratio (L)	OCV Duty L	%
OCV duty current (R)	OCV Current R	mA
OCV duty current (L)	OCV Current L	mA
Throttle motor duty	Throttle Motor Duty	%
Throttle power supply voltage	Throttle Motor Voltage	V
Sub-throttle sensor voltage	Sub-Throttle Sensor	V
Main-throttle sensor voltage	Main-Throttle Sensor	V
Sub-accelerator sensor voltage	Sub-Accelerator Sensor	V
Main-accelerator sensor voltage	Main-Accelerator Sensor	V
Memorized cruise speed	Memorized Cruise Speed	km/h
Roughness Monitor for #1 cylinder	Roughness Monitor #1	—
Roughness Monitor for #2 cylinder	Roughness Monitor #2	—
Roughness Monitor for #3 cylinder	Roughness Monitor #3	—
Roughness Monitor for #4 cylinder	Roughness Monitor #4	—
Fuel level signal	Fuel Level	V
Intake air temperature signal	Intake Air Temp.	°C or °F
Mass air flow sensor signal	Mass Air Flow	g/s
Mass air flow sensor signal	Air Flow Sensor Voltage	V

# SUBARU SELECT MONITOR

## ENGINE (DIAGNOSTICS)

Contents	Display	Unit of measure
Fuel tank pressure signal	Fuel Tank Pressure	mmHg or kPa or inHg or psi
Fuel temperature signal	Fuel Temp.	°C or °F
AT/MT identification signal	AT Vehicle ID Signal	ON or OFF
Fuel pressure control signal	PCV Solenoid Valve	ON or OFF
Drain valve signal	Vent. Solenoid Valve	ON or OFF
Tank sensor control solenoid valve signal	Tank Sensor Cntl Valve	ON or OFF
ETC Motor Relay	ETC Motor Relay	ON or OFF
Clutch SW	Clutch Switch	ON or OFF
Stop light SW	Stop Light Switch	ON or OFF
SET/COAST SW	SET/COAST Switch	ON or OFF
RESUME/ACCEL SW	RESUME/ACCEL Switch	ON or OFF
Brake SW	Brake Switch	ON or OFF
Main SW	Main Switch	ON or OFF
Ignition switch signal	Ignition Switch	ON or OFF
Test mode signal	Test Mode Signal	ON or OFF
Neutral position switch signal	Neutral Position Switch	ON or OFF
Air conditioning switch signal	A/C Switch	ON or OFF
Air conditioning signal	A/C Compressor Signal	ON or OFF
Radiator main fan relay signal	Radiator Fan Relay #1	ON or OFF
Blow-by leak diagnosis SW	Blow-by Leak Connector	ON or OFF
Knocking signal	Knocking Signal	ON or OFF
Radiator sub fan relay signal	Radiator Fan Relay #2	ON or OFF
Power steering switch signal	P/S Switch	ON or OFF
Rear oxygen sensor rich signal	Rear O <sub>2</sub> Rich Signal	ON or OFF
Starter switch signal	Starter Switch	ON or OFF
Idle switch signal	Idle Switch	ON or OFF
Crankshaft position sensor signal	Crankshaft Position Sig.	ON or OFF
Camshaft position sensor signal	Camshaft Position Sig.	ON or OFF
Rear defogger switch signal	Rear Defogger SW	ON or OFF
Blower fan switch signal	Blower Fan SW	ON or OFF
Small light switch signal	Light Switch	ON or OFF
Tumble generator valve output signal	TGV Output	ON or OFF
Tumble generator valve drive signal	TGV Drive	OPEN or CLOSE

**NOTE:**

For detailed operation procedure, refer to the SUBARU SELECT MONITOR OPERATION MANUAL.

# SUBARU SELECT MONITOR

ENGINE (DIAGNOSTICS)

## 5. READ CURRENT DATA FOR ENGINE. (OBD MODE)

- 1) On the «Main Menu» display screen, select the {Each System Check} and press the [YES] key.
  - 2) On the «System Selection Menu» display screen, select the {Engine Control System} and press the [YES] key.
  - 3) Press the [YES] key after the information of engine type is displayed.
  - 4) On the «Engine Diagnosis» display screen, select the {OBD System} and press the [YES] key.
  - 5) On the «OBD Menu» display screen, select the {Current Data Display & Save} and press the [YES] key.
  - 6) On the «Data Display Menu» display screen, select the {Data Display} and press the [YES] key.
  - 7) Using the scroll key, move the display screen up or down until desired data is shown.
- A list of the support data is shown in the following table.

Contents	Display	Unit of measure
Number of DTC	Number of DTC	—
Malfunction indicator light status	MI (MIL)	ON or OFF
Monitoring test of misfire	Misfire monitoring	Complete or incomplete
Monitoring test of fuel system	Fuel system monitoring	Complete or incomplete
Monitoring test of comprehensive component	Component monitoring	Complete or incomplete
Test of catalyst	Catalyst Diagnosis	Complete or incomplete
Test of heated catalyst	Heated catalyst	No support
Test of evaporative emission purge control system	Evaporative purge system	Complete or incomplete
Test of secondary air system	Secondary air system	No support
Test of air conditioning system refrigerant	A/C system refrigerant	No support
Test of oxygen sensor	Oxygen sensor	Complete or incomplete
Test of oxygen sensor heater	O <sub>2</sub> Heater Diagnosis	Complete or incomplete
Test of EGR system	EGR system	No support
Air fuel ratio control system for bank 1	Fuel System for Bank 1	—
Engine load data	Calculated load value	%
Engine coolant temperature signal	Coolant Temp.	°C or °F
Short term fuel trim by front oxygen (A/F) sensor	Short term fuel trim B1	%
Long term fuel trim by front oxygen (A/F) sensor	Long term fuel trim B1	%
Intake manifold absolute pressure signal	Mani. Absolute Pressure	mmHg or kPa or inHg or psi
Engine speed signal	Engine Speed	rpm
Vehicle speed signal	Vehicle Speed	km/h or MPH
Ignition timing advance for #1 cylinder	Ignition timing adv. #1	°
Intake air temperature signal	Intake Air Temp.	°C or °F
Intake air amount	Mass Air Flow	g/s
Throttle position signal	Throttle Opening Angle	%
Oxygen sensor #11	Oxygen Sensor #11	—
Oxygen sensor #12	Oxygen Sensor #12	—
Rear oxygen sensor output signal	Oxygen Sensor #12	V
Air fuel ratio correction by rear oxygen sensor	Short term fuel trim #12	%
On-board diagnostic system	OBD System	CARB-OBD2
A/F sensor output signal	A/F sensor #11	V
A/F lambda signal	A/F sensor #11	—
A/F lambda signal #11	A/F sensor #11	—
A/F sensor current #11	A/F sensor #11	mA

**NOTE:**

For detailed operation procedure, refer to the SUBARU SELECT MONITOR OPERATION MANUAL.

# SUBARU SELECT MONITOR

## ENGINE (DIAGNOSTICS)

### 6. READ FREEZE FRAME DATA FOR ENGINE. (OBD MODE)

- 1) On the «Main Menu» display screen, select the {Each System Check} and press the [YES] key.
  - 2) On the «System Selection Menu» display screen, select the {Engine Control System} and press the [YES] key.
  - 3) Press the [YES] key after the information of engine type is displayed.
  - 4) On the «Engine Diagnosis» display screen, select the {OBD System} and press the [YES] key.
  - 5) On the «OBD Menu» display screen, select the {Freeze Frame Data} and press the [YES] key.
- A list of the support data is shown in the following table.

Contents	Display	Unit of measure
DTC for freeze frame data	Freeze frame data	DTC
Air fuel ratio control system for bank 1	Fuel system for Bank1	Closed loop or Open loop
Air fuel ratio control system for bank 2	Fuel system for Bank2	Open loop
O <sub>2</sub> sensor output voltage	Oxygen Sensor #12	V
Short term fuel trim by O <sub>2</sub> sensor	Short term fuel trim #12	%
Engine load data	Calculated load value	%
Engine coolant temperature signal	Coolant Temp.	°C or °F
Short term fuel trim by front oxygen (A/F) sensor	Short term fuel trim B1	%
Long term fuel trim by front oxygen (A/F) sensor	Long term fuel trim B1	%
Intake manifold absolute pressure signal	Mani. Absolute Pressure	mmHg, kPa, inHg or psi
Engine speed signal	Engine Speed	rpm
Vehicle speed signal	Vehicle Speed	km/h or MPH
Ignition timing advance for #1 cylinder	Ignition timing adv. #1	°
Intake air temperature signal	Intake Air Temp.	°C or °F
Intake air amount	Mass Air Flow	g/s
Throttle position signal	Throttle Opening Angle	%

#### NOTE:

For detailed operation procedure, refer to the SUBARU SELECT MONITOR OPERATION MANUAL.



# SUBARU SELECT MONITOR

ENGINE (DIAGNOSTICS)

## 7. LED OPERATION MODE FOR ENGINE

- 1) On the «Main Menu» display screen, select the {Each System Check} and press the [YES] key.
- 2) On the «System Selection Menu» display screen, select the {Engine Control System} and press the [YES] key.
- 3) Press the [YES] key after the information of engine type is displayed.
- 4) On the «Engine Diagnosis» display screen, select the {Current Data Display & Save} and press the [YES] key.
- 5) On the «Data Display Menu» display screen, select the {Data & LED Display} and press the [YES] key.
- 6) Using the scroll key, move the display screen up or down until the desired data is shown.
  - A list of the support data is shown in the following table.

Contents	Display	Message	LED "ON" requirements
Ignition switch signal	Ignition Switch	ON or OFF	When ignition switch is turned to ON.
Test mode signal	Test Mode Signal	ON or OFF	When test mode connector is connected.
Neutral position switch signal	Neutral Position Switch	ON or OFF	When neutral position signal is entered.
Air conditioning switch signal	A/C Switch	ON or OFF	When air conditioning switch is turned ON.
Air conditioning relay signal	A/C Compressor Signal	ON or OFF	When air conditioning relay is in function.
Radiator main fan relay signal	Radiator Fan Relay #1	ON or OFF	When radiator main fan relay is in function.
Knocking signal	Knocking Signal	ON or OFF	When knocking signal is entered.
Radiator sub fan relay signal	Radiator Fan Relay #2	ON or OFF	When radiator sub fan relay is in function.
Rear oxygen sensor rich signal	Rear O <sub>2</sub> Rich Signal	ON or OFF	When rear oxygen sensor mixture ratio is rich.
Starter switch signal	Starter Switch Signal	ON or OFF	When starter switch signal is entered.
Idle switch signal	Idle Switch Signal	ON or OFF	When idle switch signal is entered.
Crankshaft position sensor signal	Crankshaft Position Signal	ON or OFF	When crankshaft position sensor signal is entered.
Camshaft position sensor signal	Camshaft Position Signal	ON or OFF	When camshaft position sensor signal is entered.
Power steering switch signal	P/S Switch	ON or OFF	When power steering switch is entered.
Rear defogger switch signal	Rear Defogger Switch	ON or OFF	When rear defogger switch is turned ON.
Blower fan switch signal	Blower Fan Switch	ON or OFF	When blower fan switch is turned ON.
Small light switch signal	Light Switch	ON or OFF	When small light switch is turned ON.
Tumble generator valve actuator signal	TGV Output	ON or OFF	When TGV actuator signal is entered.
Tumble generator valve drive signal	TGV Drive	Close or Open	When TGV moves and valve opens.
Fuel pressure control solenoid	PCV Solenoid Valve	ON or OFF	When fuel pressure control solenoid valve is in function.
Drain valve signal	Vent. Solenoid Valve	ON or OFF	When drain valve is in function.
Fuel tank sensor control solenoid valve signal	Fuel Tank Sensor Ctrl Valve	ON or OFF	When tank sensor control solenoid valve is in function.
Blow-by leak diagnosis SW	Blow-by Leak Connector	ON or OFF	When connected.
Handle SW	Handle SW	RHD/LHD	When the vehicle is LHD model.
ETC motor relay	ETC Motor Relay	ON or OFF	When electric throttle is in function.
Clutch SW	Clutch SW	ON or OFF	When clutch switch is turned ON.
Stop SW	Stop Light Switch	ON or OFF	When stop light switch is turned ON.
SET/CST SW	SET/COAST Switch	ON or OFF	When SET/COAST switch is turned ON.
RES/ACC SW	RESUME/ACCEL Switch	ON or OFF	When RESUME/ACCEL switch is turned ON.
Brake SW	Brake Switch	ON or OFF	When brake switch is turned ON.
Main SW	Main Switch	ON or OFF	When main switch is turned ON.

**NOTE:**

For detailed operation procedure, refer to the SUBARU SELECT MONITOR OPERATION MANUAL.

# READ DIAGNOSTIC TROUBLE CODE (DTC)

ENGINE (DIAGNOSTICS)

## 10. Read Diagnostic Trouble Code (DTC)

### A: OPERATION

#### 1. SUBARU SELECT MONITOR (NORMAL MODE)

- 1) On the «Main Menu» display screen, select the {Each System Check} and press the [YES] key.
- 2) On the «System Selection Menu» display screen, select the {Engine Control System} and press the [YES] key.
- 3) Press the [YES] key after the information of engine type is displayed.
- 4) On the «Engine Diagnosis» display screen, select the {DTC Display} and press the [YES] key.
- 5) On the «DTC Display» display screen, select the {Current DTC} or {History DTC} and press the [YES] key.

#### NOTE:

- For detailed operation procedure, refer to the SUBARU SELECT MONITOR OPERATION MANUAL.
- For detailed concerning DTC, refer to the List of Diagnostic Trouble Code (DTC). <Ref. to EN(STi)-66, List of Diagnostic Trouble Code (DTC).>

#### 2. SUBARU SELECT MONITOR (OBD MODE)

- 1) On the «Main Menu» display screen, select the {2. Each System Check} and press the [YES] key.
- 2) On the «System Selection Menu» display screen, select the {Engine Control System} and press the [YES] key.
- 3) Press the [YES] key after the information of engine type is displayed.
- 4) On the «Engine Diagnosis» display screen, select the {OBD System} and press the [YES] key.
- 5) On the «OBD Menu» display screen, select the {DTC Display} and press the [YES] key.
- 6) Make sure that a DTC is shown on the display screen.

#### NOTE:

- For detailed operation procedure, refer to the SUBARU SELECT MONITOR OPERATION MANUAL.
- For detailed concerning DTC, refer to the List of Diagnostic Trouble Code (DTC). <Ref. to EN(STi)-66, List of Diagnostic Trouble Code (DTC).>

#### 3. OBD-II GENERAL SCAN TOOL

Refers to data denoting emission-related powertrain DTC.

For details concerning DTC, refer to the List of Diagnostic Trouble Code (DTC). <Ref. to EN(STi)-66, List of Diagnostic Trouble Code (DTC).>

#### NOTE:

Refer to OBD-II general scan tool manufacturer's instruction manual to access emission-related powertrain DTC (MODE \$03).

## 11. Inspection Mode

### A: OPERATION

Carry out trouble diagnosis shown in the following DTC table.

When performing trouble diagnosis which is not shown in the DTC table, refer to the next item Drive cycle.

<Ref. to EN(STi)-40, Drive Cycle.>

DTC	Item	Condition
P0011	"A" Camshaft Position-Timing Over-Advanced or System Performance (Bank 1)	—
P0021	"A" Camshaft Position-Timing Over-Advanced or System Performance (Bank 2)	—
P0030	HO2S Heater Control Circuit (Bank 1 Sensor 1)	—
P0031	HO2S Heater Control Circuit Low (Bank 1 Sensor 1)	—
P0032	HO2S Heater Control Circuit High (Bank 1 Sensor 1)	—
P0037	HO2S Heater Control Circuit Low (Bank 1 Sensor 2)	—
P0038	HO2S Heater Control Circuit High (Bank 1 Sensor 2)	—
P0101	Mass or Volume Air Flow Circuit Range/Performance	—
P0102	Mass or Volume Air Flow Circuit Low Input	—
P0103	Mass or Volume Air Flow Circuit High Input	—
P0107	Manifold Absolute Pressure/Barometric Pressure Circuit Low Input	—
P0108	Manifold Absolute Pressure/Barometric Pressure Circuit High Input	—
P0112	Intake Air Temperature Circuit Low Input	—
P0113	Intake Air Temperature Circuit High Input	—
P0117	Engine Coolant Temperature Circuit Low Input	—
P0118	Engine Coolant Temperature Circuit High Input	—
P0122	Throttle/Pedal Position Sensor/Switch "A" Circuit Low Input	—
P0123	Throttle/Pedal Position Sensor/Switch "A" Circuit High Input	—
P0129	Atmospheric Pressure Sensor Circuit Range/Performance	—
P0131	O <sub>2</sub> Sensor Circuit Low Voltage (Bank 1 Sensor 1)	—
P0132	O <sub>2</sub> Sensor Circuit High Voltage (Bank 1 Sensor 1)	—
P0134	O <sub>2</sub> Sensor Circuit No Activity Detected (Bank 1 Sensor 1)	—
P0137	O <sub>2</sub> Sensor Circuit Low Voltage (Bank 1 Sensor 2)	—
P0138	O <sub>2</sub> Sensor Circuit High Voltage (Bank 1 Sensor 2)	—
P0182	Fuel Temperature Sensor "A" Circuit Low Input	—
P0183	Fuel Temperature Sensor "A" Circuit High Input	—
P0222	Throttle/Pedal Position Sensor/Switch "B" Circuit Low Input	—
P0223	Throttle/Pedal Position Sensor/Switch "B" Circuit High Input	—
P0230	Fuel Pump Primary Circuit	—
P0245	Turbo/Super Charger Wastegate Solenoid "A" Low	—
P0327	Knock Sensor 1 Circuit Low Input (Bank 1 or Single Sensor)	—
P0328	Knock Sensor 1 Circuit High Input (Bank 1 or Single Sensor)	—
P0335	Crankshaft Position Sensor "A" Circuit	—
P0336	Crankshaft Position Sensor "A" Circuit Range/Performance	—
P0340	Camshaft Position Sensor "A" Circuit (Bank 1 or Single Sensor)	—
P0341	Camshaft Position Sensor "A" Circuit Range/Performance (Bank 1 or Single Sensor)	—
P0345	Camshaft Position Sensor "A" Circuit (Bank 2)	—
P0447	Evaporative Emission Control System Vent Control Circuit Open	—
P0448	Evaporative Emission Control System Vent Control Circuit Shorted	—
P0452	Evaporative Emission Control System Pressure Sensor Low Input	—
P0453	Evaporative Emission Control System Pressure Sensor High Input	—

# INSPECTION MODE

## ENGINE (DIAGNOSTICS)

DTC	Item	Condition
P0458	Evaporative Emission Control System Purge Control Valve Circuit Low	—
P0462	Fuel Level Sensor Circuit Low Input	—
P0463	Fuel Level Sensor Circuit High Input	—
P0502	Vehicle Speed Sensor Circuit Low Input	—
P0503	Vehicle Speed Sensor Intermittent/Erratic/High	—
P0512	Starter Request Circuit	—
P0519	Idle Control System Malfunction (Fail-Safe)	—
P0604	Internal Control Module Random Access Memory (RAM) Error	—
P0605	Internal Control Module Read Only Memory (ROM) Error	—
P0607	Control Module Performance	—
P0638	Throttle Actuator Control Range/Performance (Bank 1)	—
P0691	Cooling Fan 1 Control Circuit Low	—
P0851	Neutral Switch Input Circuit Low	—
P0852	Neutral Switch Input Circuit High	—
P1086	Tumble Generated Valve Position Sensor 2 Circuit Low	—
P1087	Tumble Generated Valve Position Sensor 2 Circuit High	—
P1088	Tumble Generated Valve Position Sensor 1 Circuit Low	—
P1089	Tumble Generated Valve Position Sensor 1 Circuit High	—
P1091	Tumble Generated Valve System 1 (Valve Close)	—
P1093	Tumble Generated Valve System 2 (Valve Close)	—
P1094	Tumble Generated Valve Signal 1 Circuit Malfunction (Open)	—
P1095	Tumble Generated Valve Signal 1 Circuit Malfunction (Short)	—
P1096	Tumble Generated Valve Signal 2 Circuit Malfunction (Open)	—
P1097	Tumble Generated Valve Signal 2 Circuit Malfunction (Short)	—
P1110	Atmospheric Pressure sensor circuit malfunction (Low input)	—
P1111	Atmospheric Pressure sensor circuit malfunction (High input)	—
P1152	O <sub>2</sub> Sensor Circuit Range/Performance (Low) (Bank1 Sensor1)	—
P1153	O <sub>2</sub> Sensor Circuit Range/Performance (High) (Bank1 Sensor1)	—
P1160	Return Spring Failure	—
P1400	Fuel Tank Pressure Control Solenoid Valve Circuit Low	—
P1420	Fuel Tank Pressure Control Sol. Valve Circuit High	—
P1446	Fuel Tank Sensor Control Valve Circuit Low	—
P1447	Fuel Tank Sensor Control Valve Circuit High	—
P1491	Positive Crankcase Ventilation (Blow-by) Function Problem	—
P1518	Starter Switch Circuit Low Input	—
P1560	Back-up Voltage Circuit Malfunction	—
P2088	OCV Solenoid Valve Signal A Circuit Open (Bank 1)	—
P2089	OCV Solenoid Valve Signal A Circuit Short (Bank 1)	—
P2092	OCV Solenoid Valve Signal A Circuit Open (Bank 2)	—
P2093	OCV Solenoid Valve Signal A Circuit Short (Bank 2)	—
P2101	Throttle Actuator Control Motor Circuit Range/Performance	—
P2102	Throttle Actuator Control Motor Circuit Low	—
P2103	Throttle Actuator Control Motor Circuit High	—
P2109	Throttle/Pedal Position Sensor A Minimum Stop Performance	—
P2122	Throttle/Pedal Position Sensor/Switch "D" Circuit Low Input	—
P2123	Throttle/Pedal Position Sensor/Switch "D" Circuit High Input	—
P2127	Throttle/Pedal Position Sensor/Switch "E" Circuit Low Input	—
P2128	Throttle/Pedal Position Sensor/Switch "E" Circuit High Input	—
P2135	Throttle/Pedal Position Sensor/Switch "A" / "B" Voltage Rationality	—
P2138	Throttle/Pedal Position Sensor/Switch "D" / "E" Voltage Rationality	—

### 1. PREPARATION FOR THE INSPECTION MODE

- 1) Make sure that the fuel remains approx. half amount [20 — 40 ℓ (5.3 — 10.6 US gal, 4.4 — 8.8 Imp gal)] and the battery voltage is 12 V or more.
- 2) Raise the vehicle using a garage jack and place on safety stands or drive the vehicle onto free rollers.

#### WARNING:

- Before raising the vehicle, ensure the parking brake is applied.
- Do not use a pantograph jack in place of a safety stand.
- Secure a rope or wire to the front and rear towing or tie-down hooks to prevent the lateral runout of front wheels.
- Do not abruptly depress/release the clutch pedal or accelerator pedal during works even when engine is operating at low speeds since this may cause vehicle to jump off free rollers.
- In order to prevent the vehicle from slipping due to vibration, do not place any wooden blocks or similar items between the safety stands and the vehicle.
- Since the rear wheels will also rotate, do not place anything near them. Also, make sure that nobody goes in front of the vehicle.

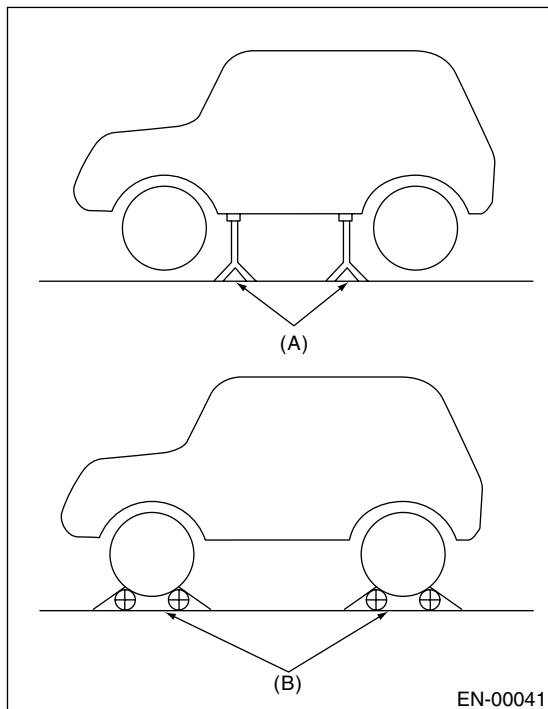

- (A) Safety stand  
(B) Free rollers

### 2. SUBARU SELECT MONITOR

- 1) Warm up the engine.
- 2) Prepare the Subaru Select Monitor kit. <Ref. to EN(STi)-7, PREPARATION TOOL, General Description.>

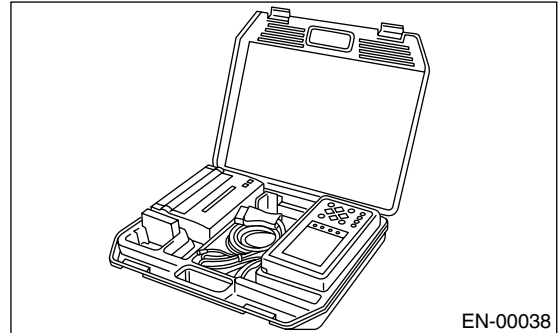

- 3) Connect the diagnosis cable to Subaru Select Monitor.
- 4) Insert the cartridge into Subaru Select Monitor. <Ref. to EN(STi)-7, PREPARATION TOOL, General Description.>

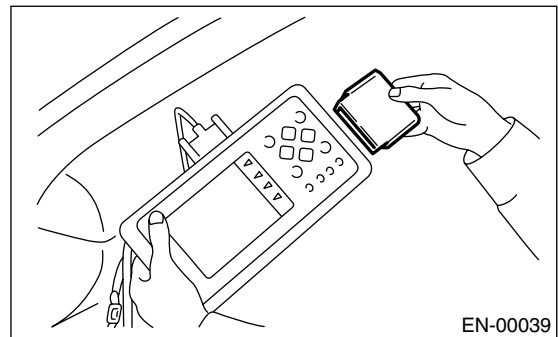

- 5) Connect the test mode connector (A) at the lower portion of instrument panel (on the driver's side).

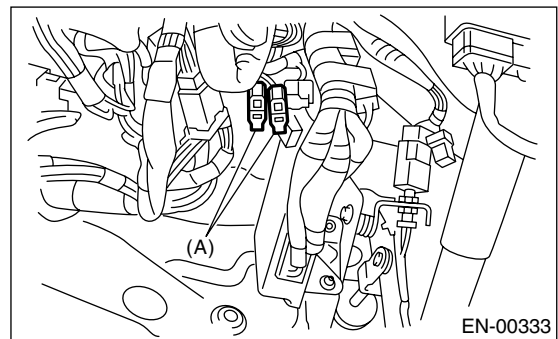

(A) Test mode connector

# INSPECTION MODE

## ENGINE (DIAGNOSTICS)

6) Connect the Subaru Select Monitor to data link connector located in the lower portion of the instrument panel (on the driver's side).

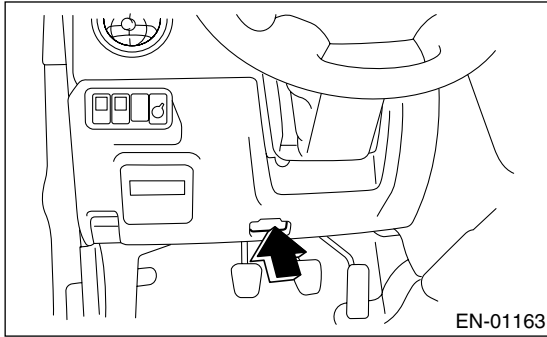

### CAUTION:

**Do not connect the scan tools except for Subaru Select Monitor and OBD-II general scan tool.**

7) Turn the ignition switch to ON (engine OFF) and Subaru Select Monitor switch to ON.

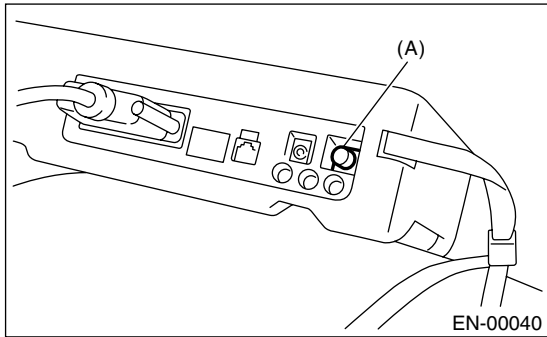

(A) Power switch

8) On the «Main Menu» display screen, select the {2. Each System Check} and press the [YES] key.

9) On the «System Selection Menu» display screen, select the {Engine Control System} and press the [YES] key.

10) Press the [YES] key after the information of engine type is displayed.

11) On the «Engine Diagnosis» display screen, select the {Dealer Check Mode Procedure} and press the [YES] key.

12) When the "Perform Inspection (Dealer Check Mode)?" is shown on the display screen, press the [YES] key.

13) Perform subsequent procedures as instructed on the display screen.

- If trouble still remains in the memory, the corresponding DTC appears on the display screen.

### NOTE:

- For detailed operation procedure, refer to the SUBARU SELECT MONITOR OPERATION MANUAL.

- For detailed concerning the DTC, refer to the List of Diagnostic Trouble Code (DTC).

<Ref. to EN(STi)-66, List of Diagnostic Trouble Code (DTC).>

- Release the parking brake.

- The speed difference between front and rear wheels may light either the ABS warning light, but this indicates no malfunctions. When the engine control diagnosis is finished, perform the ABS memory clearance procedure of self-diagnosis system.

## 3. OBD-II GENERAL SCAN TOOL

1) Warm up the engine.

2) Connect the test mode connector (A) at the lower side of instrument panel (on the driver's side).

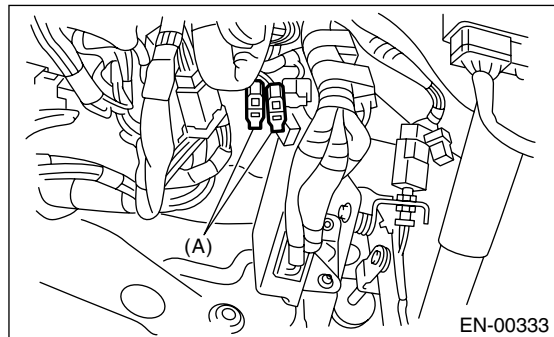

3) Connect the OBD-II general scan tool to its data link connector in the lower portion of instrument panel (on the driver's side).

### CAUTION:

**Do not connect the scan tools except for Subaru Select Monitor and OBD-II general scan tool.**

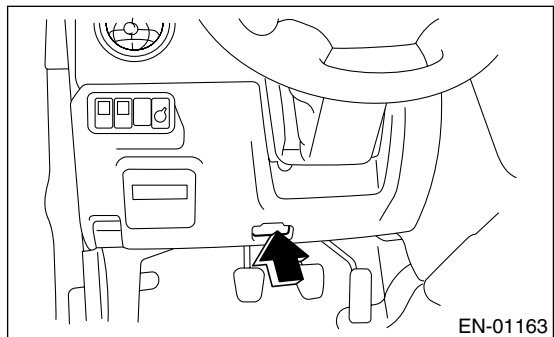

4) Start the engine.

### NOTE:

Depress the clutch pedal when starting engine.

5) Using the shift lever, turn the "N" position switch to ON.

6) Keep the engine speed in 2,500 — 3,000 rpm range for 40 seconds.

7) Place the shift lever in "1st" gear and drive the vehicle at 5 to 10 km/h (3 to 6 MPH).

NOTE:

- On AWD model, release the parking brake.
- The speed difference between front and rear wheels may light ABS warning light, but this indicates no malfunctions. When the engine control diagnosis is finished, perform the ABS memory clearance procedure of self-diagnosis system.

8) Using the OBD-II general scan tool, check for DTC and record the result(s).

NOTE:

- For detailed operation procedures, refer to the OBD-II General Scan Tool Instruction Manual.
- For detailed concerning DTC, refer to the List of Diagnostic Trouble Code (DTC).

<Ref. to EN(STi)-66, List of Diagnostic Trouble Code (DTC).>

# DRIVE CYCLE

ENGINE (DIAGNOSTICS)

## 12. Drive Cycle

### A: OPERATION

There are three drive patterns for the trouble diagnosis. Driving in the specified pattern allows to diagnose malfunctioning items listed below. After the malfunctioning items listed below are repaired, always check whether they correctly resume their functions by driving in the required drive pattern.

#### 1. PREPARATION FOR THE DRIVE CYCLE

- 1) Make sure that the fuel remains approx. half amount [20 — 40 ℓ (5.3 — 10.6 US gal, 4.4 — 8.8 Imp gal)], and battery voltage is 12 V or more.
- 2) Separate the test mode connector.

NOTE:

- Except for the engine coolant temperature specified items at starting, the diagnosis is carried out after engine warm up.
- Carry out the diagnosis which is marked \* on DTC twice, then, after finishing first diagnosis, stop the engine and do second time at the same condition.

#### 2. AFTER RUNNING 20 MINUTES AT 80 KM/H (50 MPH), IDLE ENGINE FOR 1 MINUTE.

DTC	Item	Condition
*P0125	Insufficient Coolant Temperature for Closed Loop Fuel Control	Engine coolant temperature is less than 20°C (68°F) at engine start.
*P0128	Coolant Thermostat	Engine coolant temperature is less than 55°C (131°F) at engine start.
*P0133	O <sub>2</sub> Sensor Circuit Slow Response (Bank 1 Sensor 1)	—
*P0181	Fuel Temperature Sensor A Performance Problem	—
*P0420	Catalyst System Efficiency Below Threshold (Bank 1)	—
*P0442	Evaporative Emission Control System Leak Detected (small leak)	—
*P0451	Evaporative Emission Control System Pressure Sensor Range/Performance	—
*P0456	Evaporative Emission Control System Leak Detected (very small leak)	—
*P0457	Evaporative Emission Control System Leak Detected (fuel cap loose/off)	—
P0459	Evaporative Emission Control System Purge Control Valve Circuit High	—
P0461	Fuel Level Sensor Circuit Range/Performance	—
P0692	Cooling Fan 1 Control Circuit High	—
P1443	Vent Control Solenoid Valve Function Problem	—
*P1448	Fuel Tank Sensor Control Valve Range/Performance	—
*P2096	Post Catalyst Fuel Trim System Too Lean Bank 1	—
*P2097	Post Catalyst Fuel Trim System Too Rich Bank 1	—

#### 3. IDLE FOR 10 MINUTES

NOTE:

Before the diagnosis, drive the vehicle at 10 km/h (6 MPH) or more.

DTC	Item	Condition
*P0111	Intake Air Temperature Sensor Range/Performance Problem	Engine coolant temperature is less than 30°C (86°F) at engine start.
P0171	System too Lean (Bank 1)	—
P0172	System too Rich (Bank 1)	—
*P0464	Fuel Level Sensor Circuit Intermittent	—
*P0483	Cooling Fan Rationality Check	—
*P0506	Idle Control System RPM Lower Than Expected	—
*P0507	Idle Control System RPM Higher Than Expected	—



# DRIVE CYCLE

ENGINE (DIAGNOSTICS)

## 4. DRIVE ACCORDING TO THE FOLLOWING DRIVE PATTERN

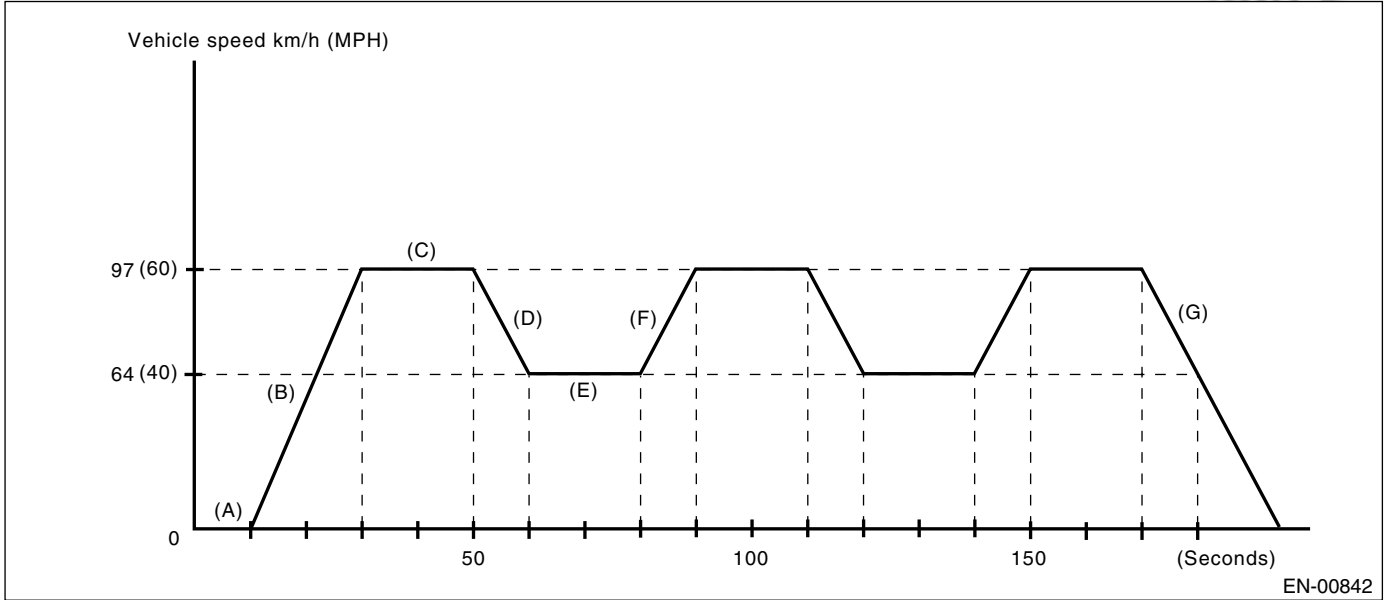

- (A) Idle engine for 10 seconds or more.
- (B) Accelerate to 97 km/h (60 MPH) within 20 seconds.
- (C) Drive vehicle at 97 km/h (60 MPH) for 20 seconds.
- (D) Decelerate with fully closed throttle to 64 km/h (40 MPH).
- (E) Drive vehicle at 64 km/h (40 MPH) for 20 seconds.
- (F) Accelerate to 97 km/h (60 MPH) within 10 seconds.
- (G) Stop vehicle with throttle fully closed.

DTC	Item	Condition
P0068	Manifold Absolute Pressure/Barometric Pressure Circuit Range/Performance	—
*P0139	O <sub>2</sub> Sensor Circuit Slow Response (Bank 1 Sensor 2)	—
P0244	Turbo/Supercharger Wastegate Solenoid "A" Range/Performance	—
P0246	Turbo/Supercharger Wastegate Solenoid "A" High	—
*P0301	Cylinder 1 Misfire Detected	In some cases, diagnosis may complete at once.
*P0302	Cylinder 2 Misfire Detected	In some cases, diagnosis may complete at once.
*P0303	Cylinder 3 Misfire Detected	In some cases, diagnosis may complete at once.
*P0304	Cylinder 4 Misfire Detected	In some cases, diagnosis may complete at once.
P1090	Tumble Generated Valve System 1 (Valve Open)	—
P1092	Tumble Generated Valve System 2 (Valve Open)	—

## **13. Clear Memory Mode**

### **A: OPERATION**

#### **1. SUBARU SELECT MONITOR (NORMAL MODE)**

- 1) On the «Main Menu» display screen, select the {2. Each System Check} and press the [YES] key.
- 2) On the «System Selection Menu» display screen, select the {Engine Control System} and press the [YES] key.
- 3) Press the [YES] key after the information of engine type is displayed.
- 4) On the «Engine Diagnosis» display screen, select the {Clear Memory} and press the [YES] key.
- 5) When the 'Done' and 'Turn Ignition Switch OFF' are shown on the display screen, turn the ignition switch to OFF, and then turn the Subaru Select Monitor to OFF.

**NOTE:**

For detailed operation procedure, refer to the SUBARU SELECT MONITOR OPERATION MANUAL.

#### **2. SUBARU SELECT MONITOR (OBD MODE)**

- 1) On the «Main Menu» display screen, select the {2. Each System Check} and press the [YES] key.
- 2) On the «System Selection Menu» display screen, select the {Engine Control System} and press the [YES] key.
- 3) Press the [YES] key after the information of engine type is displayed.
- 4) On the «Engine Diagnosis» display screen, select the {OBD System} and press the [YES] key.
- 5) On the «OBD Menu» display screen, select the {4. Diagnosis Code(s) Cleared} and press the [YES] key.
- 6) When the 'Clear Diagnostic Code?' is shown on the display screen, press the [YES] key.
- 7) Turn the ignition switch to OFF, and then turn the Subaru Select Monitor to OFF.

**NOTE:**

For detailed operation procedure, refer to the SUBARU SELECT MONITOR OPERATION MANUAL.

#### **3. OBD-II GENERAL SCAN TOOL**

For clear memory procedures using the OBD-II general scan tool, refer to the OBD-II General Scan Tool Instruction Manual.

# COMPULSORY VALVE OPERATION CHECK MODE

ENGINE (DIAGNOSTICS)

## 14. Compulsory Valve Operation Check Mode

### A: OPERATION

1) Prepare the Subaru Select Monitor kit. <Ref. to EN(STi)-7, PREPARATION TOOL, General Description.>

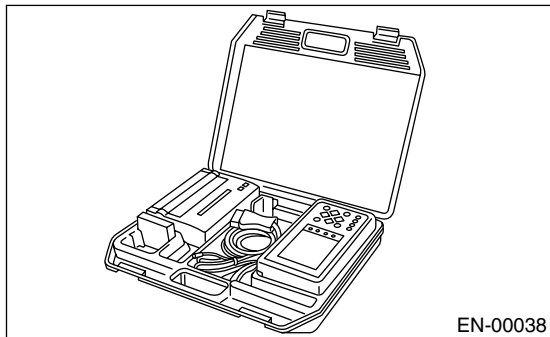

2) Connect the diagnosis cable to Subaru Select Monitor.

3) Insert the cartridge into Subaru Select Monitor. <Ref. to EN(STi)-7, PREPARATION TOOL, General Description.>

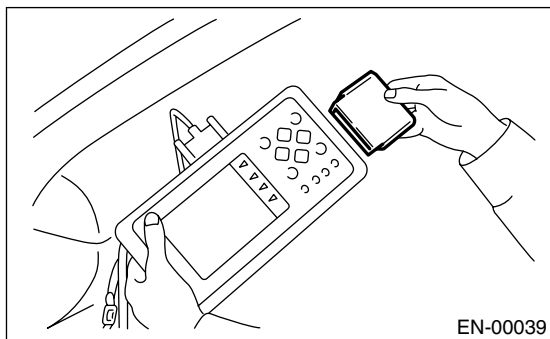

4) Connect the test mode connector (A) at the lower portion of instrument panel (on the driver's side).

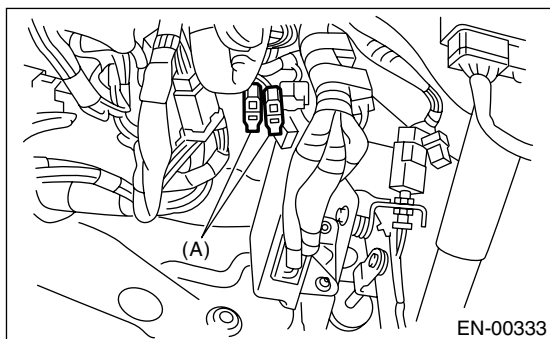

5) Connect the Subaru Select Monitor to data link connector located in the lower portion of instrument panel (on the driver's side).

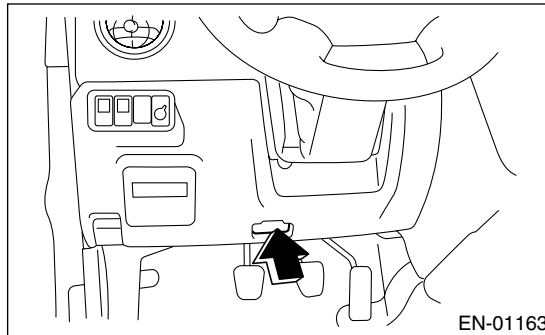

### CAUTION:

**Do not connect scan tools except for the Subaru Select Monitor and OBD-II general scan tool.**

6) Turn the ignition switch to ON (engine OFF) and Subaru Select Monitor switch to ON.

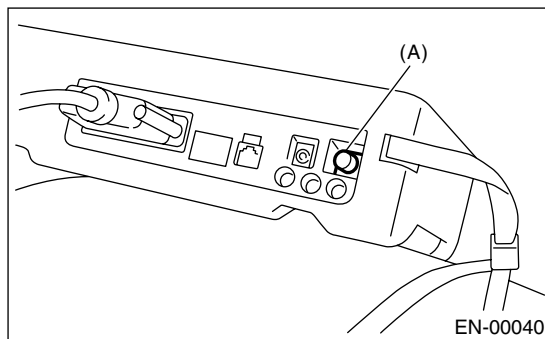

(A) Power switch

7) On the «Main Menu» display screen, select the {2. Each System Check} and press the [YES] key.

8) On the «System Selection Menu» display screen, select the {Engine Control System} and press the [YES] key.

9) Press the [YES] key after the information of engine type is displayed.

10) On the «Engine Diagnosis» display screen, select the {System Operation Check Mode} and press the [YES] key.

11) On the «System Operation Check Mode» display screen, select the {Actuator ON/OFF Operation} and press the [YES] key.

12) Select the desired compulsory actuator on the «Actuator ON/OFF Operation» display screen and press the [YES] key.

13) Pressing the [NO] key completes the compulsory operation check mode. The display will then return to the «Actuator ON/OFF Operation» screen.

# COMPULSORY VALVE OPERATION CHECK MODE

## ENGINE (DIAGNOSTICS)

- A list of support data is shown in the following table.

Contents	Display
Compulsory fuel pump relay operation check	Fuel Pump Relay
Compulsory radiator fan relay operation check	Radiator Fan Relay
Compulsory air conditioning relay operation check	A/C Compressor Relay
Compulsory purge control solenoid valve operation check	CPC Solenoid Valve
Compulsory pressure control solenoid valve operation check	PCV Solenoid Valve
Compulsory drain valve operation check	Vent. Control Solenoid Valve
Compulsory fuel tank sensor control valve operation check	Fuel Tank Sensor Control Valve

### NOTE:

- The following parts will be displayed but not functional because they are not installed on the vehicle.

Display
EGR Solenoid Valve
ASV Solenoid Valve
FICD Solenoid
Pressure Switching Sol. 1
Pressure Switching Sol. 2
AAI Solenoid Valve
Turbocharger Wastegate Solenoid

- For detailed operation procedure, refer to the SUBARU SELECT MONITOR OPERATION MANUAL.

## 15. Malfunction Indicator Light

### A: PROCEDURE

1. Activation of check malfunction indicator light. <Ref. to EN(STi)-46, ACTIVATION OF MALFUNCTION INDICATOR LIGHT, Malfunction Indicator Light.>
↓
2. Check that the malfunction indicator light does not come on. <Ref. to EN(STi)-47, MALFUNCTION INDICATOR LIGHT DOES NOT COME ON., Malfunction Indicator Light.>
↓
3. Check that the malfunction indicator light does not go off. <Ref. to EN(STi)-49, MALFUNCTION INDICATOR LIGHT DOES NOT GO OFF., Malfunction Indicator Light.>
↓
4. Check that the malfunction indicator light does not blink at a cycle of 3 Hz. <Ref. to EN(STi)-50, MALFUNCTION INDICATOR LIGHT DOES NOT BLINK AT A CYCLE OF 3 HZ., Malfunction Indicator Light.>
↓
5. Check that the malfunction indicator light remains blinking at a cycle of 3 Hz. <Ref. to EN(STi)-52, MALFUNCTION INDICATOR LIGHT REMAINS BLINKING AT A CYCLE OF 3 HZ., Malfunction Indicator Light.>

# MALFUNCTION INDICATOR LIGHT

## ENGINE (DIAGNOSTICS)

### B: ACTIVATION OF MALFUNCTION INDICATOR LIGHT

1) When the ignition switch is turned to ON (engine off), the malfunction indicator light in the combination meter illuminates.

**NOTE:**

If the malfunction indicator light does not illuminate, perform diagnostics of the malfunction indicator light circuit or the combination meter circuit. <Ref. to EN(STi)-47, MALFUNCTION INDICATOR LIGHT DOES NOT COME ON., Malfunction Indicator Light.>

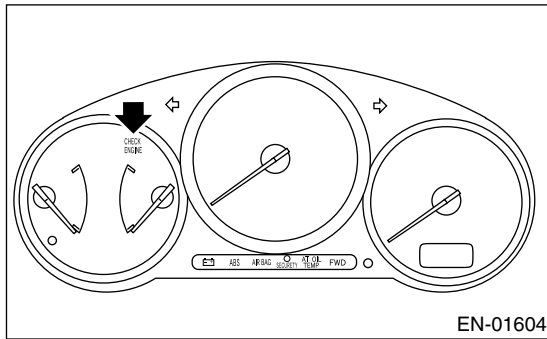

EN-01604

2) After starting the engine, the malfunction indicator light goes out. If it does not, either the engine or the emission control system is malfunctioning.

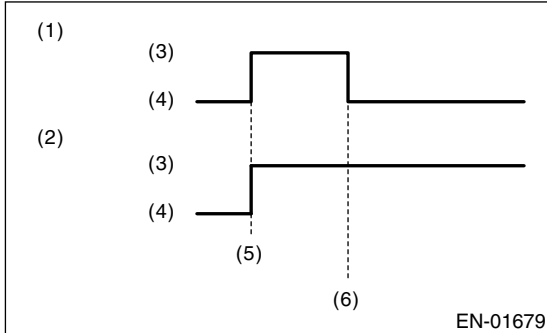

EN-01679

- (1) No trouble
- (2) Trouble occurs
- (3) ON
- (4) OFF
- (5) Ignition switch ON
- (6) Engine start

3) If the diagnosis system senses a misfire which could damage the catalyzer, the malfunction indicator light will blink at a cycle of 1 Hz.

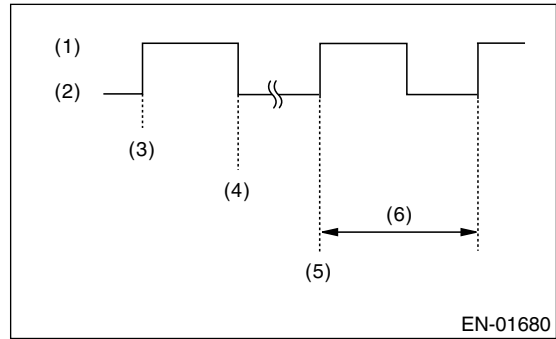

EN-01680

- (1) ON
- (2) OFF
- (3) Ignition switch ON
- (4) Engine start
- (5) Misfire start
- (6) 1 second

4) When the ignition switch is turned to ON (engine off) or to START with the test mode connector connected, the malfunction indicator light blinks at a cycle of 3 Hz.

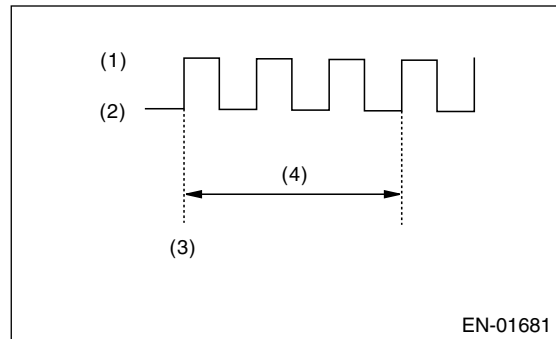

EN-01681

- (1) ON
- (2) OFF
- (3) Ignition switch ON
- (4) 1 second

# MALFUNCTION INDICATOR LIGHT

ENGINE (DIAGNOSTICS)

## C: MALFUNCTION INDICATOR LIGHT DOES NOT COME ON.

- **DIAGNOSIS:**
  - The malfunction indicator light circuit is shorted.
- **TROUBLE SYMPTOM:**
  - When the ignition switch is turned to ON (engine OFF), malfunction indicator light does not come on.
- **WIRING DIAGRAM:**

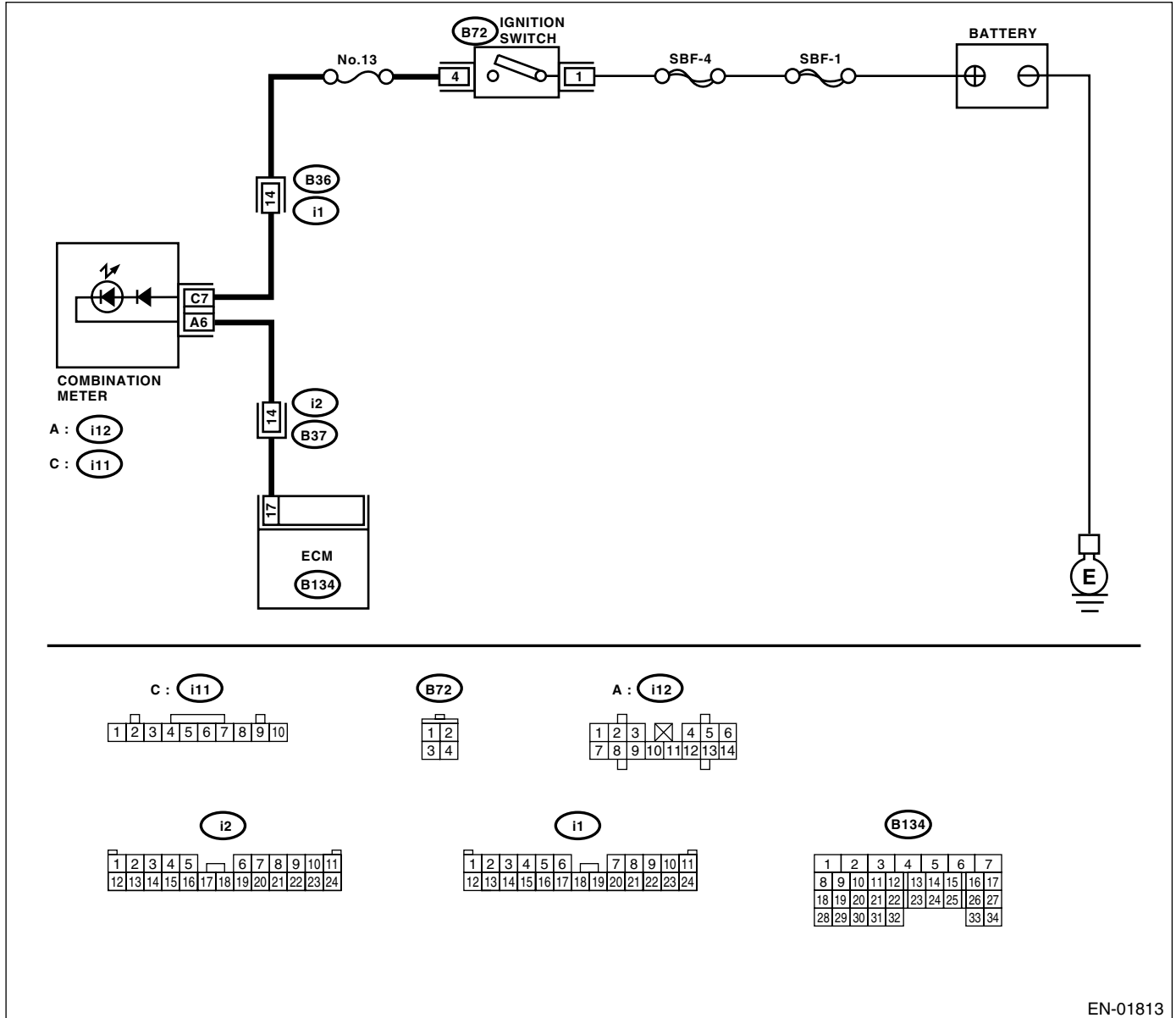

EN-01813

Step	Check	Yes	No	
1	<b>CHECK OUTPUT SIGNAL FROM ECM.</b> 1) Turn the ignition switch to ON. 2) Measure the voltage between ECM connector and chassis ground. <b>Connector &amp; terminal (B134) No. 17 (+) — Chassis ground (-):</b>	Is the voltage less than 1 V?	Go to step 4.	Go to step 2.
2	<b>CHECK POOR CONTACT.</b>	Does the malfunction indicator light come on when shaking or pulling ECM connector and harness?	Repair the poor contact in ECM connector.	Go to step 3.

# MALFUNCTION INDICATOR LIGHT

## ENGINE (DIAGNOSTICS)

Step	Check	Yes	No
<b>3</b> <b>CHECK ECM CONNECTOR.</b>	Is the ECM connector correctly connected?	Replace the ECM. <Ref. to FU(STi)-41, Engine Control Module (ECM).>	Repair the connection of ECM connector.
<b>4</b> <b>CHECK HARNESS BETWEEN COMBINATION METER AND ECM CONNECTOR.</b> 1) Turn the ignition switch to OFF. 2) Remove the combination meter. <Ref. to IDI-10, Combination Meter Assembly.> 3) Disconnect the connector from ECM and combination meter. 4) Measure the resistance of harness between ECM and combination meter connector. <b>Connector &amp; terminal</b> <b>(B134) No. 17 — (i12) No. 6:</b>	Is the resistance less than 1 $\Omega$ ?	Go to step 5.	Repair the harness and connector.  NOTE: In this case, repair the following: <ul style="list-style-type: none"> <li>• Open circuit in harness between ECM and combination meter connector</li> <li>• Poor contact in coupling connector</li> </ul>
<b>5</b> <b>CHECK POOR CONTACT.</b> Check poor contact in combination meter connector.	Is there poor contact in combination meter connector?	Repair the poor contact in combination meter connector.	Go to step 6.
<b>6</b> <b>CHECK HARNESS BETWEEN COMBINATION METER AND IGNITION SWITCH CONNECTOR.</b> 1) Turn the ignition switch to ON. 2) Measure the voltage between combination meter connector and chassis ground. <b>Connector &amp; terminal</b> <b>(i11) No. 7 (+) — Chassis ground (-):</b>	Is the voltage more than 10 V?	Replace the combination meter circuit board. <Ref. to IDI-10, Combination Meter Assembly.>	Check the following and repair if necessary.  NOTE: <ul style="list-style-type: none"> <li>• Blown out fuse (No. 13)</li> <li>• Open or short circuit in harness between fuse (No. 13) and battery terminal</li> <li>• Poor contact in ignition switch connector</li> </ul>



# MALFUNCTION INDICATOR LIGHT

ENGINE (DIAGNOSTICS)

## D: MALFUNCTION INDICATOR LIGHT DOES NOT GO OFF.

### • DIAGNOSIS:

- The malfunction indicator light circuit is shorted.

### • TROUBLE SYMPTOM:

- Although malfunction indicator light comes on when engine runs, but DTC is not shown on Subaru Select Monitor or OBD-II general scan tool display.

### • WIRING DIAGRAM:

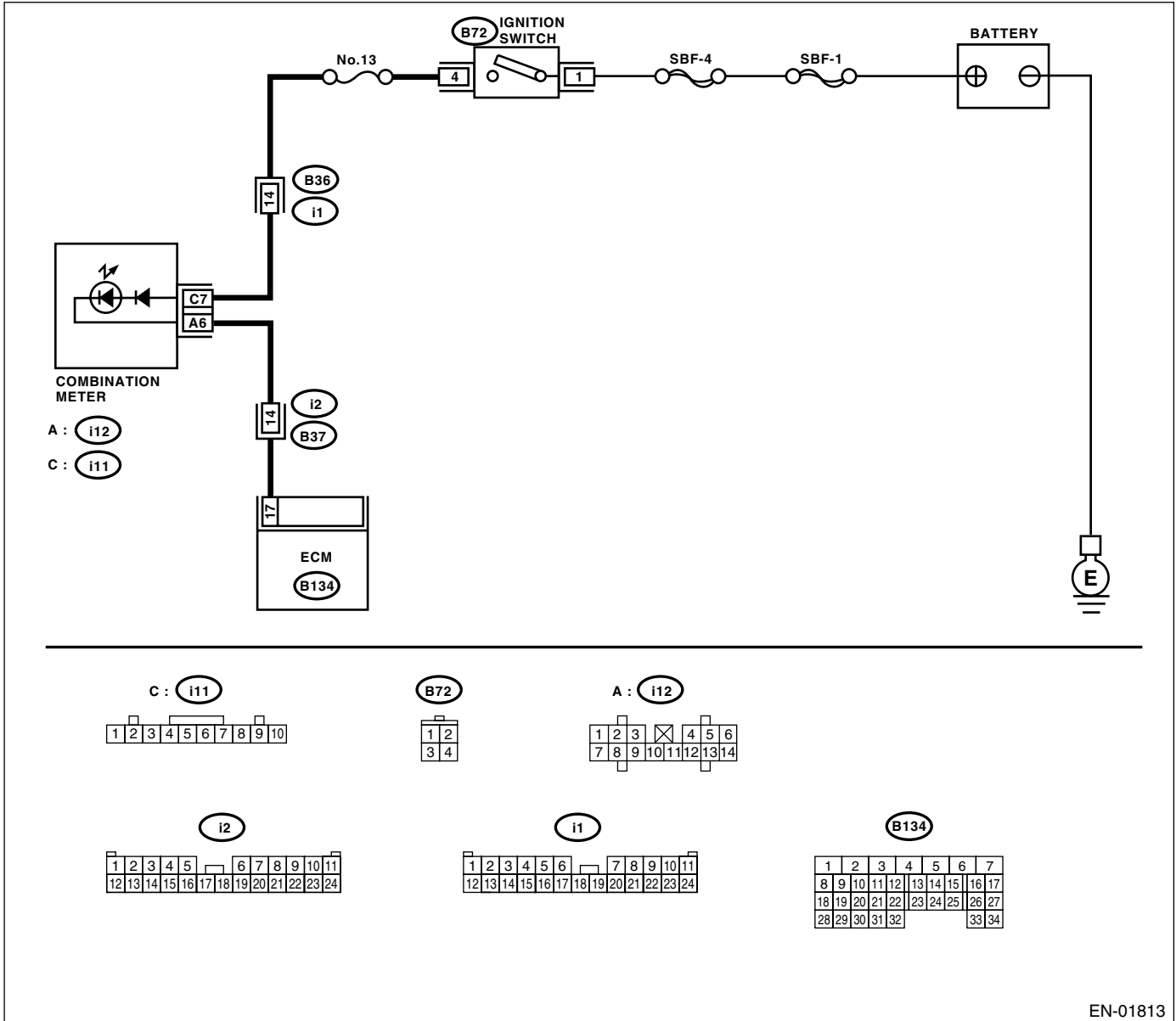

Step	Check	Yes	No	
1	<b>CHECK HARNESS BETWEEN COMBINATION METER AND ECM CONNECTOR.</b> 1) Turn the ignition switch to OFF. 2) Disconnect the connector from ECM. 3) Turn the ignition switch to ON.	Does the malfunction indicator light come on?	Repair the short circuit in harness between combination meter and ECM connector.	Replace the ECM. <Ref. to FU(STi)-41, Engine Control Module (ECM).>

# MALFUNCTION INDICATOR LIGHT

ENGINE (DIAGNOSTICS)

## E: MALFUNCTION INDICATOR LIGHT DOES NOT BLINK AT A CYCLE OF 3 HZ.

• **DIAGNOSIS:**

- The malfunction indicator light circuit is open or shorted.
- Test mode connector circuit is open.

• **TROUBLE SYMPTOM:**

- During inspection mode, malfunction indicator light does not blink at a cycle of 3 Hz.

• **WIRING DIAGRAM:**

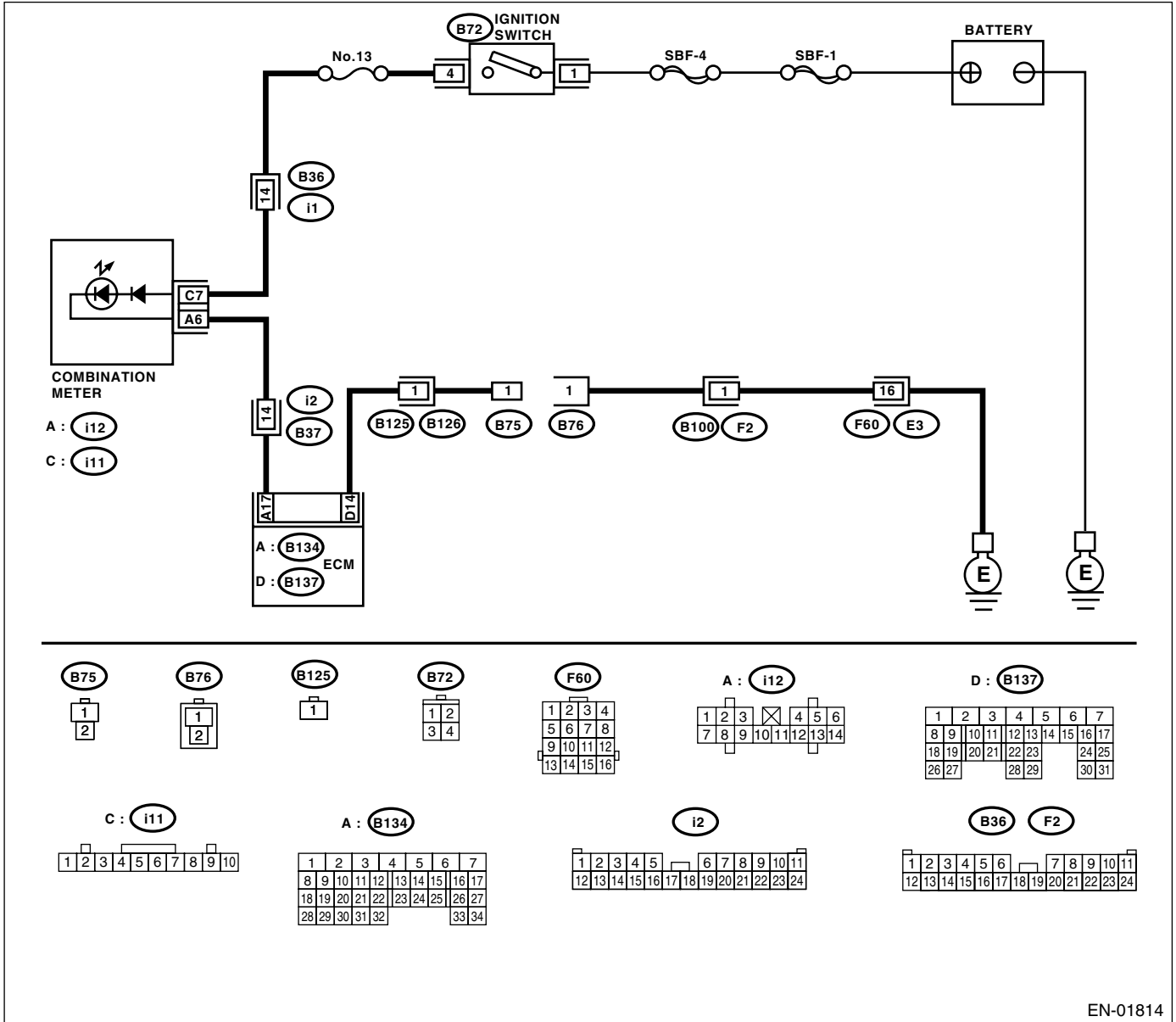

EN-01814

# MALFUNCTION INDICATOR LIGHT

ENGINE (DIAGNOSTICS)

	Step	Check	Yes	No
1	<b>CHECK STATUS OF MALFUNCTION INDICATOR LIGHT.</b> 1) Turn the ignition switch to OFF. 2) Disconnect the test mode connector. 3) Turn the ignition switch to ON. (engine OFF)	Does the malfunction indicator light come on?	Go to step 2.	Repair the malfunction indicator light circuit. <Ref. to EN(STi)-47, MALFUNCTION INDICATOR LIGHT DOES NOT COME ON., Malfunction Indicator Light.>
2	<b>CHECK HARNESS BETWEEN COMBINATION METER AND ECM CONNECTOR.</b> 1) Turn the ignition switch to OFF. 2) Disconnect the connector from ECM. 3) Turn the ignition switch to ON.	Does the malfunction indicator light come on?	Repair the ground short circuit in harness between combination meter and ECM connector.	Go to step 3.
3	<b>CHECK HARNESS BETWEEN TEST MODE CONNECTOR AND CHASSIS GROUND.</b> 1) Turn the ignition switch to OFF. 2) Disconnect the connector from ECM. 3) Measure the resistance of harness between test mode connector and chassis ground. <i>Connector &amp; terminal</i> <i>(B76) No. 1 — Chassis ground:</i>	Is the resistance less than 1 $\Omega$ ?	Go to step 4.	Repair the harness and connector. NOTE: In this case, repair the following: • Open circuit in harness between test mode connector and chassis ground
4	<b>CHECK POOR CONTACT.</b> Check poor contact in ECM connector.	Is there poor contact in ECM connector?	Repair the poor contact in ECM connector.	Go to step 5.
5	<b>CHECK HARNESS BETWEEN ECM AND TEST MODE CONNECTOR.</b> 1) Connect the test mode connector. 2) Measure the resistance of harness between ECM and chassis ground. <i>Connector &amp; terminal</i> <i>(B137) No. 14 — Chassis ground:</i>	Is the resistance less than 1 $\Omega$ ?	Go to step 6.	Repair the open circuit in harness between ECM and test mode connector.
6	<b>CHECK POOR CONTACT.</b> Check poor contact in ECM connector.	Is there poor contact in ECM connector?	Repair the poor contact in ECM connector.	Replace the ECM. <Ref. to FU(STi)-41, Engine Control Module (ECM).>

# MALFUNCTION INDICATOR LIGHT

ENGINE (DIAGNOSTICS)

## F: MALFUNCTION INDICATOR LIGHT REMAINS BLINKING AT A CYCLE OF 3 HZ.

- **DIAGNOSIS:**
  - Test mode connector circuit is shorted.
- **TROUBLE SYMPTOM:**
  - Malfunction indicator light blinks at a cycle of 3 Hz when ignition switch is turned to ON.
- **WIRING DIAGRAM:**

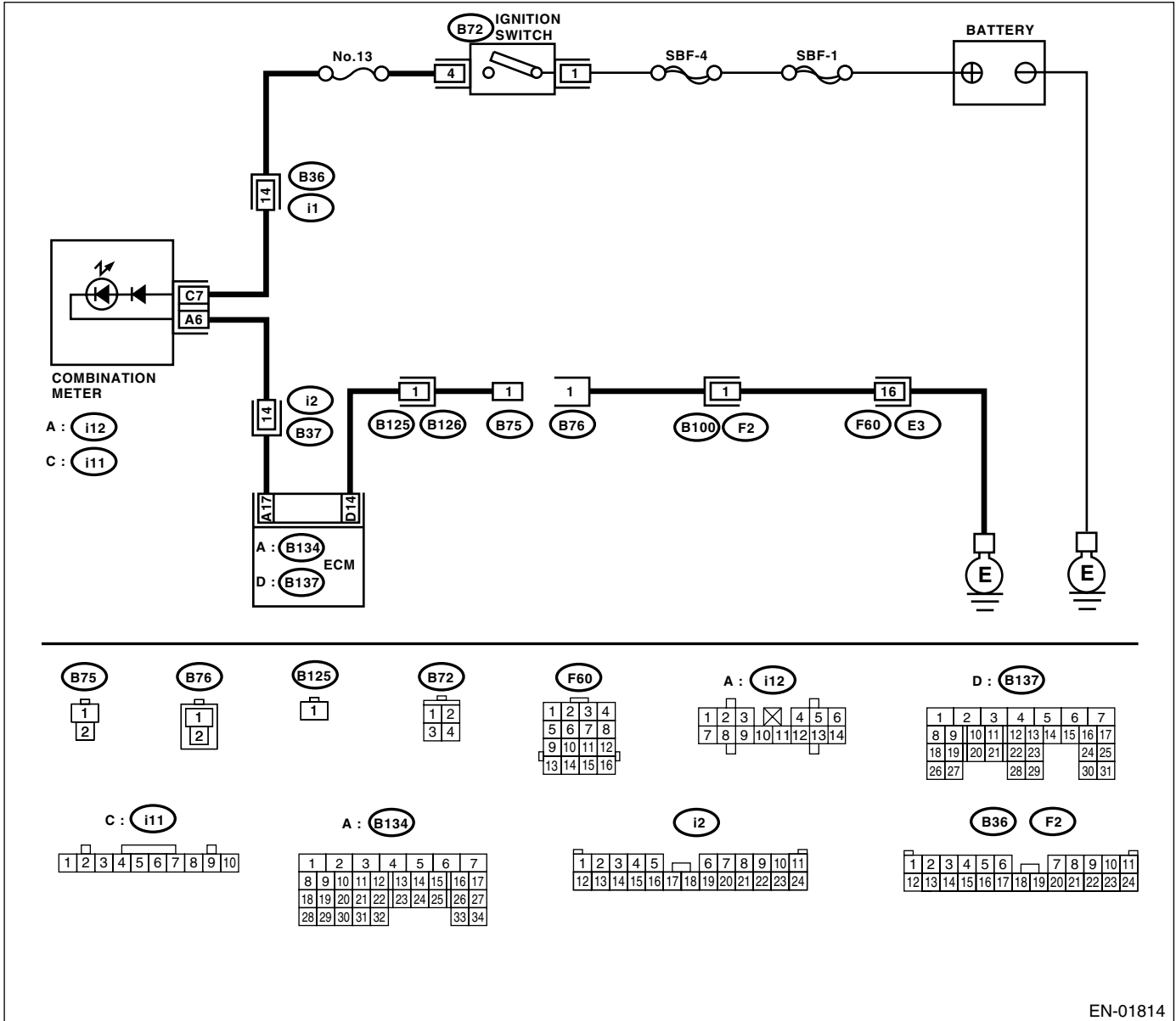

EN-01814

Step	Check	Yes	No
1 <b>CHECK TEST MODE CONNECTOR.</b> 1) Disconnect the test mode connector. 2) Turn the ignition switch to ON.	Does the malfunction indicator light blink?	Go to step 2.	System is in good order. <b>NOTE:</b> Malfunction indicator light blinks at a cycle of 3 Hz when test mode connector is connected.

# MALFUNCTION INDICATOR LIGHT

ENGINE (DIAGNOSTICS)

Step	Check	Yes	No
<p><b>2</b>    <b>CHECK HARNESS BETWEEN ECM CONNECTOR AND ENGINE GROUNDING TERMINAL.</b> 1) Turn the ignition switch to OFF. 2) Disconnect the connector from ECM. 3) Measure the resistance of harness between ECM connector and chassis ground. <b>Connector &amp; terminal</b> <b>(B137) No. 14 — Chassis ground:</b></p>	<p>Is the resistance less than 5 <math>\Omega</math>?</p>	<p>Repair the short circuit in harness between ECM and test mode connector.</p>	<p>Replace the ECM. &lt;Ref. to FU(STi)-41, Engine Control Module (ECM).&gt;</p>

# DIAGNOSTICS FOR ENGINE STARTING FAILURE

ENGINE (DIAGNOSTICS)

## 16. Diagnostics for Engine Starting Failure

### A: PROCEDURE

1. Check the fuel level.
↓
2. Inspection of starter motor circuit. <Ref. to EN(STi)-55, STARTER MOTOR CIRCUIT, Diagnostics for Engine Starting Failure.>
↓
3. Inspection of ECM power supply and ground line. <Ref. to EN(STi)-58, CONTROL MODULE POWER SUPPLY AND GROUND LINE, Diagnostics for Engine Starting Failure.>
↓
4. Inspection of ignition control system. <Ref. to EN(STi)-60, IGNITION CONTROL SYSTEM, Diagnostics for Engine Starting Failure.>
↓
5. Inspection of fuel pump circuit. <Ref. to EN(STi)-63, FUEL PUMP CIRCUIT, Diagnostics for Engine Starting Failure.>
↓
6. Inspection of fuel injector circuit. <Ref. to EN(STi)-64, FUEL INJECTOR CIRCUIT, Diagnostics for Engine Starting Failure.>

# DIAGNOSTICS FOR ENGINE STARTING FAILURE

ENGINE (DIAGNOSTICS)

## B: STARTER MOTOR CIRCUIT

### CAUTION:

After repair or replacement of faulty parts, conduct Clear Memory Mode <Ref. to EN(STi)-42, OPERATION, Clear Memory Mode.> and Inspection Mode <Ref. to EN(STi)-35, OPERATION, Inspection Mode.>.

### • WIRING DIAGRAM:

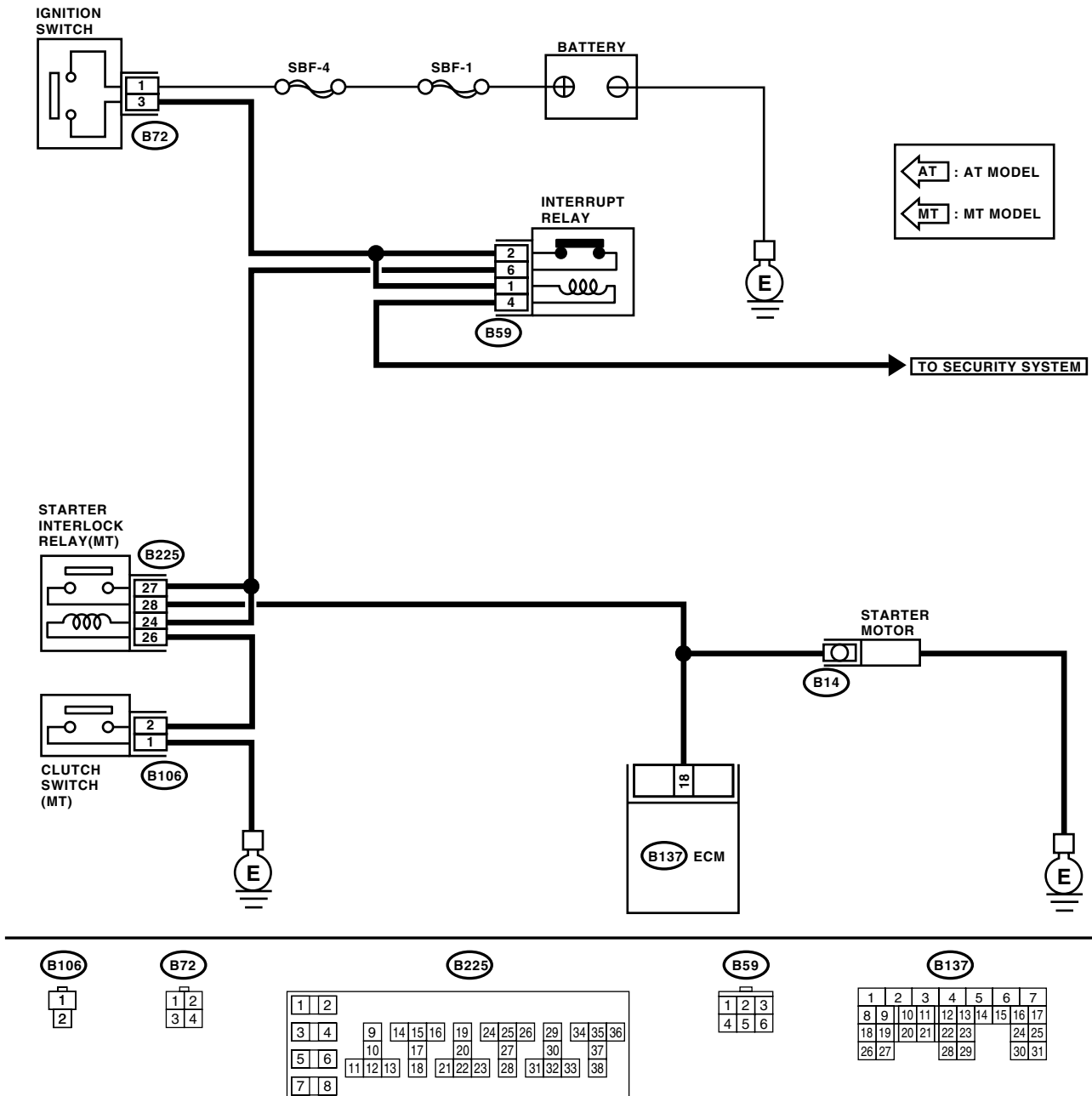

EN-01815

# DIAGNOSTICS FOR ENGINE STARTING FAILURE

## ENGINE (DIAGNOSTICS)

Step	Check	Yes	No
<b>1</b>	<b>CHECK OPERATION OF STARTER MOTOR.</b>	Go to step 2.	Go to step 3.
<b>2</b>	<b>CHECK DTC.</b>	Using the List of Diagnostic Trouble Code (DTC), check the appropriate DTC. <Ref. to EN(STi)-66, List of Diagnostic Trouble Code (DTC).>	Repair the poor contact in ECM connector.
<b>3</b>	<b>CHECK INPUT SIGNAL FOR STARTER MOTOR.</b> 1)Turn the ignition switch to OFF. 2)Disconnect the connector from starter motor. 3)Turn the ignition switch to START. 4)Measure the power supply voltage between starter motor connector terminal and engine ground. <b>Connector &amp; terminal</b> <b>(B14) No. 1 (+) — Engine ground (-):</b>  NOTE: Depress the clutch pedal.	Go to step 4.	Go to step 5.
<b>4</b>	<b>CHECK GROUND CIRCUIT OF STARTER MOTOR.</b> 1)Turn the ignition switch to OFF. 2)Disconnect the terminal from starter motor. 3)Measure the resistance of ground cable between ground cable terminal and engine ground.	Check the starter motor. <Ref. to SC(H4SO)-7, Starter.>	Repair the open circuit of ground cable.
<b>5</b>	<b>CHECK HARNESS BETWEEN BATTERY AND IGNITION SWITCH CONNECTOR.</b> 1)Disconnect the connector from ignition switch. 2)Measure the power supply voltage between ignition switch connector and chassis ground. <b>Connector &amp; terminal</b> <b>(B72) No. 1 (+) — Chassis ground (-):</b>	Go to step 6.	Check the following, repair if necessary. • Fuse is blown out. • Open circuit in harness between ignition switch and battery.
<b>6</b>	<b>CHECK IGNITION SWITCH.</b> 1)Disconnect the connector from ignition switch. 2)Measure the resistance between ignition switch terminals while turning ignition switch to START. <b>Terminals</b> <b>No. 1 — No. 3:</b>	Go to step 7.	Replace the ignition switch.
<b>7</b>	<b>CHECK INPUT VOLTAGE OF STARTER INTERLOCK RELAY.</b> 1)Turn the ignition switch to OFF. 2)Disconnect the connector from starter interlock relay. 3)Connect the connector to ignition switch. 4)Measure the input voltage between starter interlock relay connector and chassis ground while turning ignition switch to START. <b>Connector &amp; terminal</b> <b>(B104) No. 27 (+) — Chassis ground (-):</b> <b>(B104) No. 24 (+) — Chassis ground (-):</b>	Go to step 8.	Repair open or short circuit to ground in harness between starter interlock relay and ignition switch.  NOTE: Check security system (if equipped). <Ref. to SL-20, Security System.>



# DIAGNOSTICS FOR ENGINE STARTING FAILURE

ENGINE (DIAGNOSTICS)

Step	Check	Yes	No
<b>8 CHECK STARTER INTERLOCK RELAY.</b> 1)Connect the battery to starter interlock relay terminals No. 26 and No. 24. 2)Measure the resistance between starter interlock relay terminals. <i>Terminals</i> <i>No. 27 — No. 28:</i>	Is the resistance less than 1 $\Omega$ ?	Go to step 9.	Replace the starter interlock relay.
<b>9 CHECK GROUND CIRCUIT OF CLUTCH SWITCH.</b> 1)Disconnect the connector from clutch switch. 2)Measure the resistance between clutch switch connector and chassis ground. <i>Connector &amp; terminal</i> <i>(B106) No. 1 — Chassis ground:</i>	Is the resistance less than 5 $\Omega$ ?	Go to step 10.	Repair open circuit of ground cable.
<b>10 CHECK CLUTCH SWITCH.</b> Measure the resistance between clutch switch terminals while depressing the clutch pedal. <i>Terminals</i> <i>No. 1 — No. 2:</i>	Is the resistance less than 1 $\Omega$ ?	Go to step 11.	Replace the clutch switch. <Ref. to CL-30, Clutch Switch.>
<b>11 CHECK CLUTCH SWITCH CIRCUIT.</b> 1)Connect the connector to clutch switch. 2)Measure the resistance between starter interlock relay connector and chassis ground while depressing the clutch pedal. <i>Connector &amp; terminal</i> <i>(B104) No. 26 — Chassis ground:</i>	Is the resistance less than 1 $\Omega$ ?	Repair short circuit to ground in harness between starter interlock relay and starter motor.	Repair open circuit in harness between starter interlock relay and clutch switch.

# DIAGNOSTICS FOR ENGINE STARTING FAILURE

ENGINE (DIAGNOSTICS)

## C: CONTROL MODULE POWER SUPPLY AND GROUND LINE

### CAUTION:

After repair or replacement of faulty parts, conduct Clear Memory Mode <Ref. to EN(STi)-42, OPERATION, Clear Memory Mode.> and Inspection Mode <Ref. to EN(STi)-35, OPERATION, Inspection Mode.>.

### • WIRING DIAGRAM:

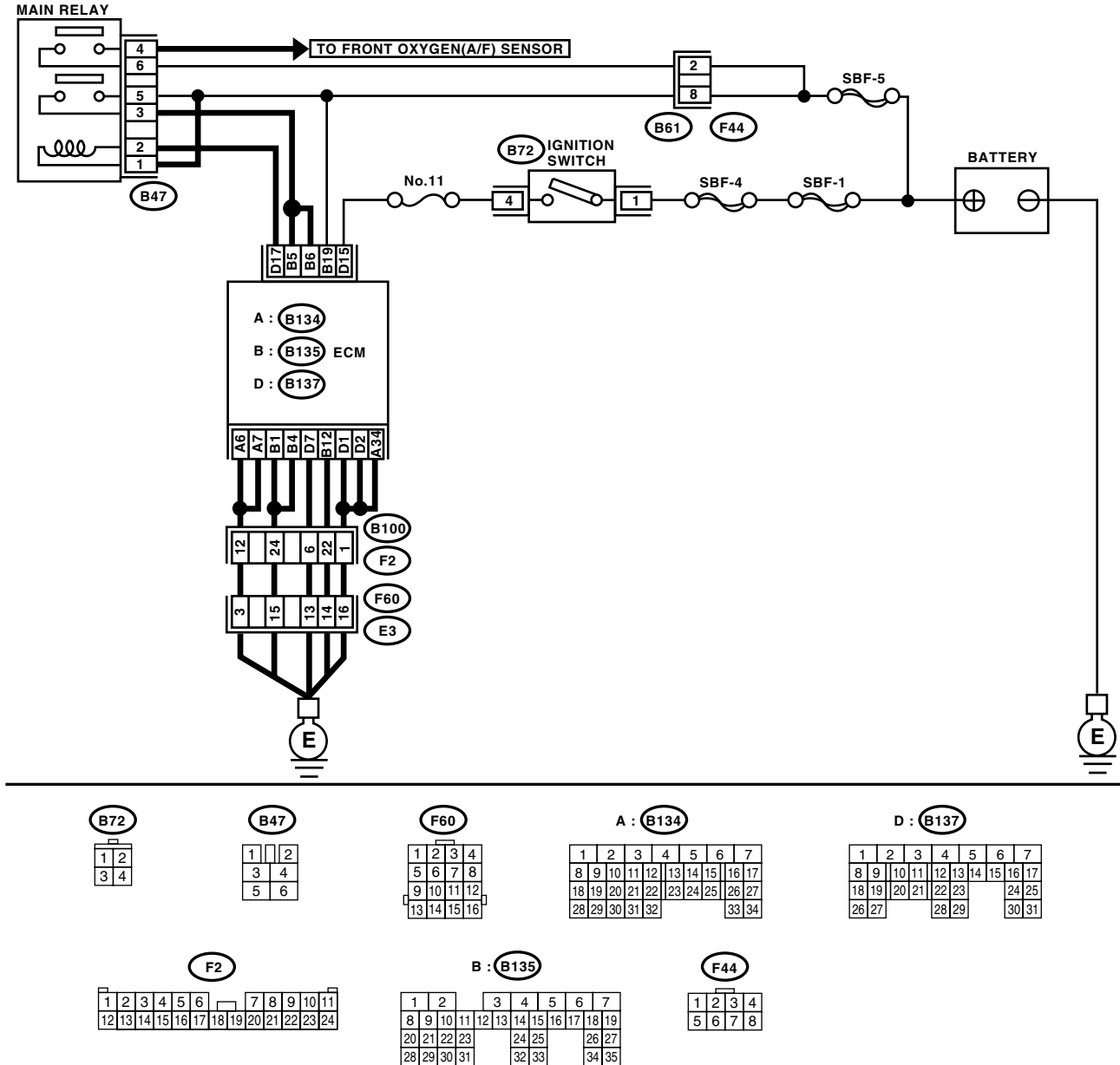

EN-01816

# DIAGNOSTICS FOR ENGINE STARTING FAILURE

ENGINE (DIAGNOSTICS)

Step	Check	Yes	No
<p><b>1 CHECK MAIN RELAY.</b>                      1) Turn the ignition switch to OFF.                      2) Remove the main relay.                      3) Connect the battery to main relay terminals No. 1 and No. 2.                      4) Measure the resistance between main relay terminals.</p> <p><b>Terminals</b>  <b>No. 3 — No. 5:</b>  <b>No. 4 — No. 6:</b></p>	Is the resistance less than 10 Ω?	Go to step 2.	Replace the main relay.
<p><b>2 CHECK GROUND CIRCUIT OF ECM.</b>                      1) Disconnect the connector from ECM.                      2) Measure the resistance of harness between ECM and chassis ground.</p> <p><b>Connector &amp; terminal</b>  <b>(B134) No. 6 — Chassis ground:</b>  <b>(B134) No. 7 — Chassis ground:</b>  <b>(B134) No. 34 — Chassis ground:</b>  <b>(B135) No. 1 — Chassis ground:</b>  <b>(B135) No. 4 — Chassis ground:</b>  <b>(B135) No. 12 — Chassis ground:</b>  <b>(B137) No. 1 — Chassis ground:</b>  <b>(B137) No. 2 — Chassis ground:</b>  <b>(B137) No. 7 — Chassis ground:</b></p>	Is the resistance less than 5 Ω?	Go to step 3.	Repair the open circuit in harness between ECM connector and engine grounding terminal.
<p><b>3 CHECK INPUT VOLTAGE OF ECM.</b>                      Measure the voltage between ECM connector and chassis ground.</p> <p><b>Connector &amp; terminal</b>  <b>(B135) No. 19 (+) — Chassis ground (-):</b>  <b>(B137) No. 15 (+) — Chassis ground (-):</b></p>	Is the voltage more than 10 V?	Go to step 4.	Repair the open or ground short circuit of power supply circuit.
<p><b>4 CHECK INPUT VOLTAGE OF MAIN RELAY.</b>                      Measure the voltage between main relay connector and chassis ground.</p> <p><b>Connector &amp; terminal</b>  <b>(B47) No. 1 (+) — Chassis ground (-):</b>  <b>(B47) No. 5 (+) — Chassis ground (-):</b>  <b>(B47) No. 6 (+) — Chassis ground (-):</b></p>	Is the voltage more than 10 V?	Go to step 5.	Repair the open or ground short circuit in harness of power supply circuit.
<p><b>5 CHECK INPUT VOLTAGE OF ECM.</b>                      1) Connect the main relay connector.                      2) Turn the ignition switch to ON.                      3) Measure the voltage between ECM connector and chassis ground.</p> <p><b>Connector &amp; terminal</b>  <b>(B135) No. 5 (+) — Chassis ground (-):</b>  <b>(B135) No. 6 (+) — Chassis ground (-):</b>  <b>(B137) No. 17 (+) — Chassis ground (-):</b></p>	Is the voltage more than 10 V?	Check the ignition control system. <Ref. to EN(STi)-60, IGNITION CONTROL SYSTEM, Diagnostics for Engine Starting Failure.>	Repair the open or ground short circuit in harness between ECM connector and main relay connector.

# DIAGNOSTICS FOR ENGINE STARTING FAILURE

ENGINE (DIAGNOSTICS)

## D: IGNITION CONTROL SYSTEM

### CAUTION:

After repair or replacement of faulty parts, conduct Clear Memory Mode <Ref. to EN(STi)-42, OPERATION, Clear Memory Mode.> and Inspection Mode <Ref. to EN(STi)-35, OPERATION, Inspection Mode.>.

### • WIRING DIAGRAM:

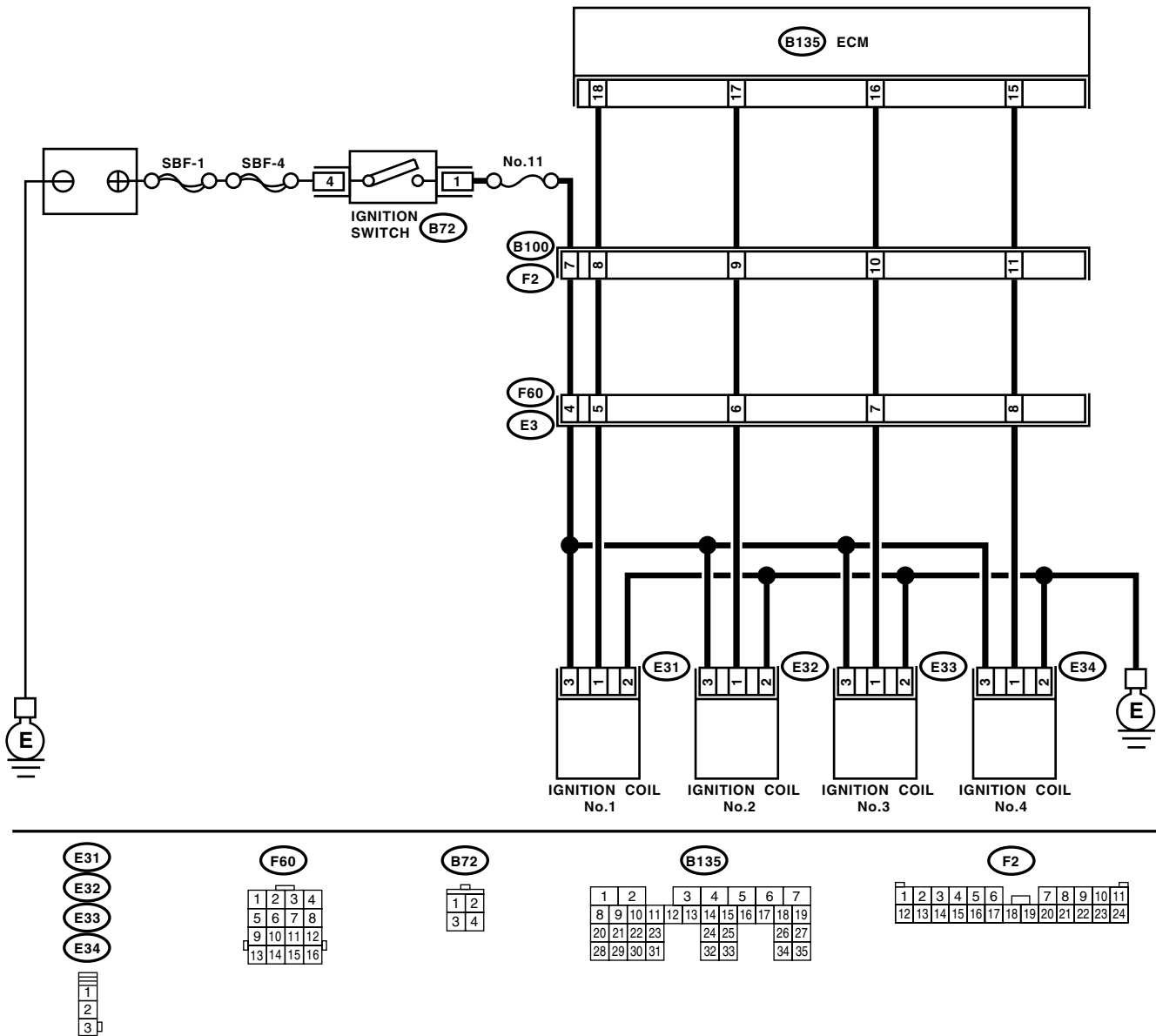

EN-01817

# DIAGNOSTICS FOR ENGINE STARTING FAILURE

ENGINE (DIAGNOSTICS)

Step	Check	Yes	No
<b>1 CHECK SPARK PLUG CONDITION.</b> 1) Remove the spark plug. <Ref. to IG(STi)-5, INSTALLATION, Spark Plug.> 2) Check the spark plug condition. <Ref. to IG(STi)-5, INSPECTION, Spark Plug.>	Is the spark plug's status OK?	Go to step 2.	Replace the spark plug.
<b>2 CHECK IGNITION SYSTEM FOR SPARKS.</b> 1) Connect the spark plug to ignition coil. 2) Release the fuel pressure. <Ref. to FU(STi)-45, RELEASING OF FUEL PRESSURE, OPERATION, Fuel.> 3) Contact the spark plug's thread portion on engine. 4) While opening the throttle valve fully, crank engine to check that spark occurs at each cylinder.	Does spark occur at each cylinder?	Check the fuel pump system. <Ref. to EN(STi)-63, FUEL PUMP CIRCUIT, Diagnostics for Engine Starting Failure.>	Go to step 3.
<b>3 CHECK POWER SUPPLY CIRCUIT FOR IGNITION COIL &amp; IGNITOR ASSEMBLY.</b> 1) Turn the ignition switch to OFF. 2) Disconnect the connector from ignition coil & ignitor assembly. 3) Turn the ignition switch to ON. 4) Measure the power supply voltage between ignition coil & ignitor assembly connector and engine ground.  <i>Connector &amp; terminal</i> (E31) No. 3 (+) — Engine ground (-): (E32) No. 3 (+) — Engine ground (-): (E33) No. 3 (+) — Engine ground (-): (E34) No. 3 (+) — Engine ground (-):	Is the voltage more than 10 V?	Go to step 4.	Repair the harness and connector.  NOTE: In this case, repair the following: • Open circuit in harness between ignition coil & ignitor assembly, and ignition switch connector • Poor contact in coupling connectors
<b>4 CHECK HARNESS OF IGNITION COIL &amp; IGNITOR ASSEMBLY GROUND CIRCUIT.</b> 1) Turn the ignition switch to OFF. 2) Measure the resistance between ignition coil & ignitor assembly connector and engine ground.  <i>Connector &amp; terminal</i> (E31) No. 2 — Engine ground: (E32) No. 2 — Engine ground: (E33) No. 2 — Engine ground: (E34) No. 2 — Engine ground:	Is the resistance less than 5 Ω?	Go to step 5.	Repair the harness and connector.  NOTE: In this case, repair the following: • Open circuit in harness between ignition coil & ignitor assembly connector and engine grounding terminal
<b>5 CHECK HARNESS BETWEEN ECM AND IGNITION COIL &amp; IGNITOR ASSEMBLY CONNECTOR.</b> 1) Turn the ignition switch to OFF. 2) Disconnect the connector from ECM. 3) Disconnect the connector from ignition coil & ignitor assembly. 4) Measure the resistance of harness between ECM and ignition coil & ignitor assembly connector.  <i>Connector &amp; terminal</i> (B135) No. 15 — (E34) No. 1: (B135) No. 16 — (E33) No. 1: (B135) No. 17 — (E32) No. 1: (B135) No. 18 — (E31) No. 1:	Is the resistance less than 1 Ω?	Go to step 6.	Repair the harness and connector.  NOTE: In this case, repair the following: • Open circuit in harness between ECM and ignition coil & ignitor assembly connector • Poor contact in coupling connector

# DIAGNOSTICS FOR ENGINE STARTING FAILURE

## ENGINE (DIAGNOSTICS)

	Step	Check	Yes	No
6	<b>CHECK HARNESS BETWEEN ECM AND IGNITION COIL &amp; IGNITOR ASSEMBLY CONNECTOR.</b> Measure the resistance of harness between ECM and engine ground. <b>Connector &amp; terminal:</b> <i>(B135) No. 15 — Engine ground:</i> <i>(B135) No. 16 — Engine ground:</i> <i>(B135) No. 17 — Engine ground:</i> <i>(B135) No. 18 — Engine ground:</i>	Is the resistance more than 1 M $\Omega$ ?	Go to step 7.	Repair the ground short circuit in harness between ECM and ignition coil & ignitor assembly connector.
7	<b>CHECK POOR CONTACT.</b> Check poor contact in ECM connector.	Is there poor contact in ECM connector?	Repair the poor contact in ECM connector.	Replace the ignition coil and ignitor assembly.

# DIAGNOSTICS FOR ENGINE STARTING FAILURE

ENGINE (DIAGNOSTICS)

## E: FUEL PUMP CIRCUIT

### CAUTION:

After repair or replacement of faulty parts, conduct Clear Memory Mode <Ref. to EN(STi)-42, OPERATION, Clear Memory Mode.> and Inspection Mode <Ref. to EN(STi)-35, OPERATION, Inspection Mode.>.

### • WIRING DIAGRAM:

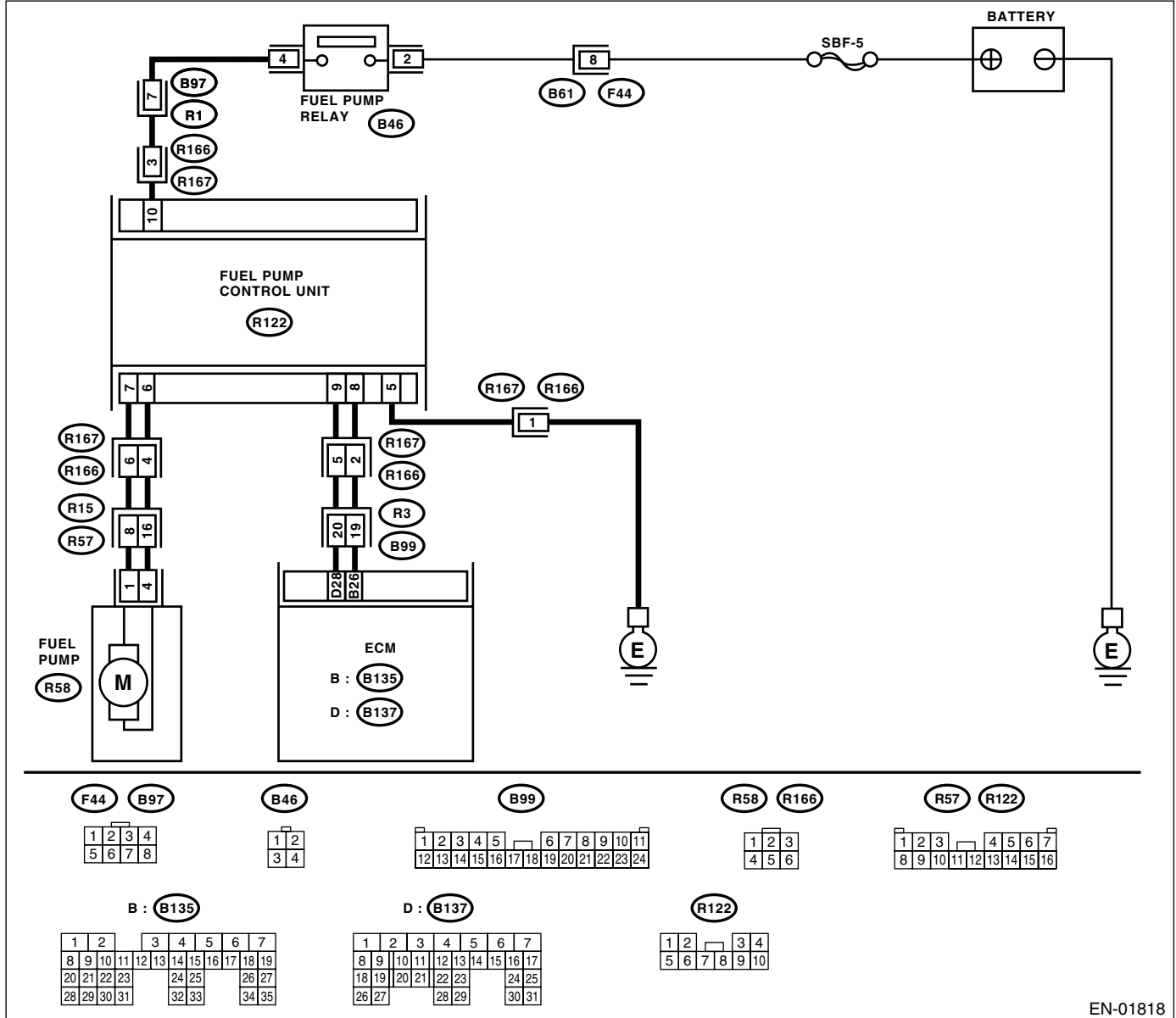

EN-01818

Step	Check	Yes	No
<p><b>1 CHECK OPERATING SOUND OF FUEL PUMP.</b>                      Make sure that the fuel pump is in operation for 2 seconds when turning ignition switch to ON.                      NOTE:                      Fuel pump operation check can also be executed using the Subaru Select Monitor.                      For the procedure, refer to "Compulsory Valve Operation Check Mode". &lt;Ref. to EN(STi)-43, Compulsory Valve Operation Check Mode.&gt;</p>	<p>Does the fuel pump produce "operating" sound?</p>	<p>Check the fuel injector circuit.                      &lt;Ref. to EN(STi)-64, FUEL INJECTOR CIRCUIT, Diagnostics for Engine Starting Failure.&gt;</p>	<p>Display the DTC.                      &lt;Ref. to EN(STi)-34, OPERATION, Read Diagnostic Trouble Code (DTC).&gt;</p>

# DIAGNOSTICS FOR ENGINE STARTING FAILURE

ENGINE (DIAGNOSTICS)

## F: FUEL INJECTOR CIRCUIT

### CAUTION:

After repair or replacement of faulty parts, conduct Clear Memory Mode <Ref. to EN(STi)-42, OPERATION, Clear Memory Mode.> and Inspection Mode <Ref. to EN(STi)-35, OPERATION, Inspection Mode.>.

### • WIRING DIAGRAM:

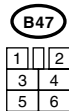
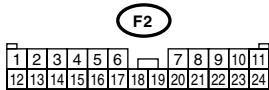
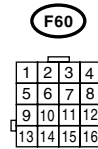
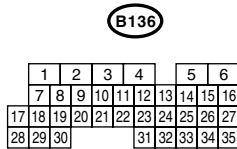
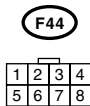
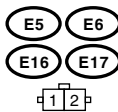
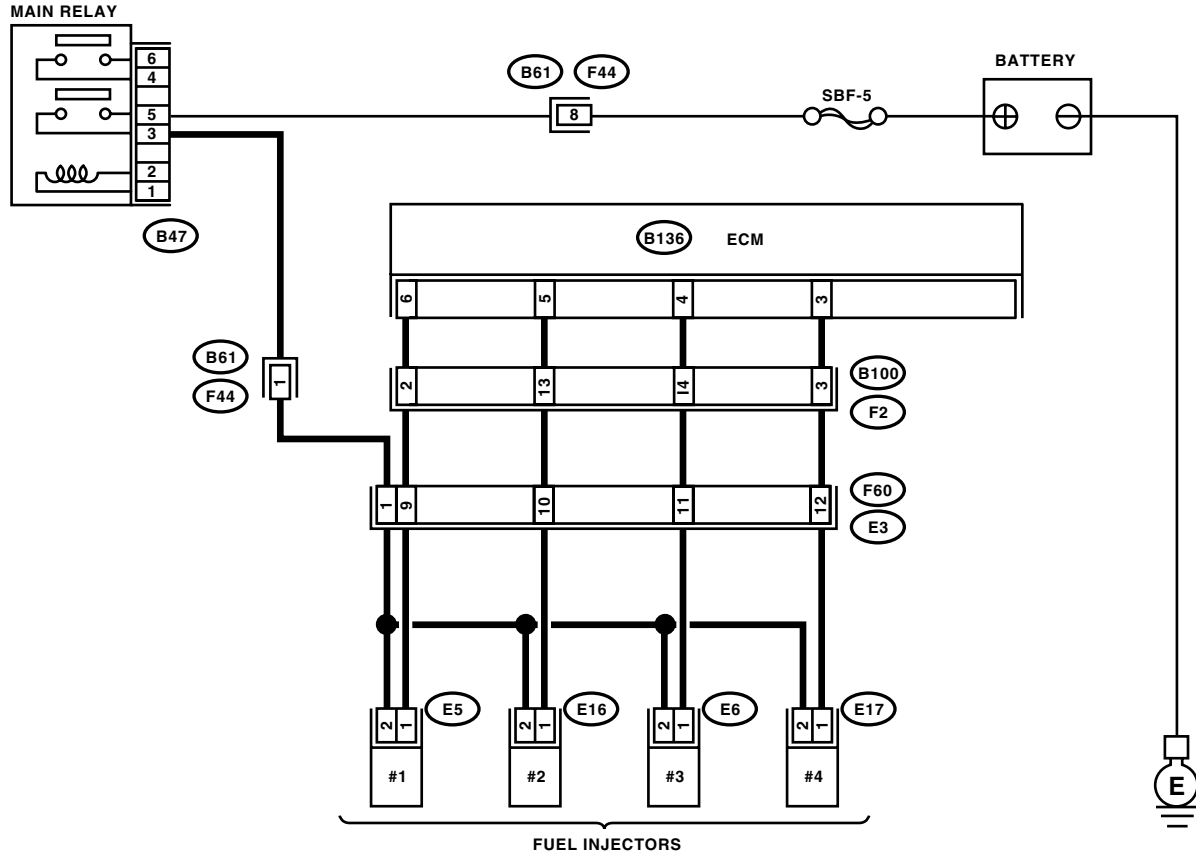

EN-01819



# DIAGNOSTICS FOR ENGINE STARTING FAILURE

ENGINE (DIAGNOSTICS)

Step	Check	Yes	No
<p><b>1 CHECK OPERATION OF EACH FUEL INJECTOR.</b> While cranking the engine, check that each fuel injector emits “operating” sound. Use a sound scope or attach a screwdriver to injector for this check.</p>	Does the fuel injector emit “operating” sound?	Check the fuel pressure. <Ref. to ME(STi)-27, INSPECTION, Fuel Pressure.>	Go to step 2.
<p><b>2 CHECK POWER SUPPLY TO EACH FUEL INJECTOR.</b> 1)Turn the ignition switch to OFF. 2)Disconnect the connector from fuel injector. 3)Turn the ignition switch to ON. 4)Measure the power supply voltage between the fuel injector terminal and engine ground. <b>Connector &amp; terminal</b> <b>#1 (E5) No. 2 (+) — Engine ground (-):</b> <b>#2 (E16) No. 2 (+) — Engine ground (-):</b> <b>#3 (E6) No. 2 (+) — Engine ground (-):</b> <b>#4 (E17) No. 2 (+) — Engine ground (-):</b></p>	Is the voltage more than 10 V?	Go to step 3.	Repair the harness and connector. NOTE: In this case, repair the following: <ul style="list-style-type: none"> <li>• Open circuit in harness between main relay and fuel injector connector</li> <li>• Poor contact in main relay connector</li> <li>• Poor contact in coupling connector</li> <li>• Poor contact in fuel injector connector</li> </ul>
<p><b>3 CHECK HARNESS BETWEEN ECM AND FUEL INJECTOR CONNECTOR.</b> 1)Disconnect the connector from ECM. 2)Measure the resistance of harness between ECM and fuel injector connector. <b>Connector &amp; terminal</b> <b>(B136) No. 6 — (E5) No. 1:</b> <b>(B136) No. 5 — (E16) No. 1:</b> <b>(B136) No. 4 — (E6) No. 1:</b> <b>(B136) No. 3 — (E6) No. 1:</b></p>	Is the resistance less than 1 Ω?	Go to step 4.	Repair the harness and connector. NOTE: In this case, repair the following: <ul style="list-style-type: none"> <li>• Open circuit in harness between ECM and fuel injector connector</li> <li>• Poor contact in coupling connector</li> </ul>
<p><b>4 CHECK HARNESS BETWEEN ECM AND FUEL INJECTOR CONNECTOR.</b> Measure the resistance of harness between ECM and fuel injector connector. <b>Connector &amp; terminal</b> <b>(B136) No. 6 — Chassis ground:</b> <b>(B136) No. 5 — Chassis ground:</b> <b>(B136) No. 4 — Chassis ground:</b> <b>(B136) No. 3 — Chassis ground:</b></p>	Is the resistance less than 1 Ω?	Repair the ground short circuit in harness between ECM and fuel injector connector.	Go to step 5.
<p><b>5 CHECK EACH FUEL INJECTOR.</b> 1)Turn the ignition switch to OFF. 2)Measure the resistance between each fuel injector terminals. <b>Terminals</b> <b>No. 1 — No. 2:</b></p>	Is the resistance 5 — 20 Ω?	Go to step 6.	Replace the faulty fuel injector.
<p><b>6 CHECK POOR CONTACT.</b> Check poor contact in ECM connector.</p>	Is there poor contact in ECM connector?	Repair the poor contact in ECM connector.	Inspection using “General Diagnostic Table”. <Ref. to EN(STi)-359, INSPECTION, General Diagnostic Table.>

# LIST OF DIAGNOSTIC TROUBLE CODE (DTC)

ENGINE (DIAGNOSTICS)

## 17. List of Diagnostic Trouble Code (DTC)

### A: LIST

DTC	Item	Index
P0011	A Camshaft Position-Timing Over-Advanced or System Performance (Bank 1)	<Ref. to EN(STi)-73, DTC P0011 — “A” CAMSHAFT POSITION-TIMING OVER-ADVANCED OR SYSTEM PERFORMANCE (BANK 1) —, Diagnostic Procedure with Diagnostic Trouble Code (DTC).>
P0021	A Camshaft Position-Timing Over-Advanced or System Performance (Bank 2)	<Ref. to EN(STi)-74, DTC P0021 — “A” CAMSHAFT POSITION-TIMING OVER-ADVANCED OR SYSTEM PERFORMANCE (BANK 2) —, Diagnostic Procedure with Diagnostic Trouble Code (DTC).>
P0030	HO2S Heater Control Circuit (Bank 1 Sensor 1)	<Ref. to EN(STi)-75, DTC P0030 — HO2S HEATER CONTROL CIRCUIT (BANK 1 SENSOR 1) —, Diagnostic Procedure with Diagnostic Trouble Code (DTC).>
P0031	HO2S Heater Control Circuit Low (Bank 1 Sensor 1)	<Ref. to EN(STi)-77, DTC P0031 — HO2S HEATER CONTROL CIRCUIT LOW (BANK 1 SENSOR 1) —, Diagnostic Procedure with Diagnostic Trouble Code (DTC).>
P0032	HO2S Heater Control Circuit High (Bank 1 Sensor 1)	<Ref. to EN(STi)-80, DTC P0032 — HO2S HEATER CONTROL CIRCUIT HIGH (BANK 1 SENSOR 1) —, Diagnostic Procedure with Diagnostic Trouble Code (DTC).>
P0037	HO2S Heater Control Circuit Low (Bank 1 Sensor 2)	<Ref. to EN(STi)-82, DTC P0037 — HO2S HEATER CONTROL CIRCUIT LOW (BANK 1 SENSOR 2) —, Diagnostic Procedure with Diagnostic Trouble Code (DTC).>
P0038	HO2S Heater Control Circuit High (Bank 1 Sensor 2)	<Ref. to EN(STi)-85, DTC P0038 — HO2S HEATER CONTROL CIRCUIT HIGH (BANK 1 SENSOR 2) —, Diagnostic Procedure with Diagnostic Trouble Code (DTC).>
P0068	Manifold Absolute Pressure/Barometric Pressure Circuit Range/Performance	<Ref. to EN(STi)-87, DTC P0068 — MANIFOLD ABSOLUTE PRESSURE/BAROMETRIC PRESSURE CIRCUIT RANGE/PERFORMANCE —, Diagnostic Procedure with Diagnostic Trouble Code (DTC).>
P0101	Mass or Volume Air Flow Circuit Range/Performance	<Ref. to EN(STi)-89, DTC P0101 — MASS OR VOLUME AIR FLOW CIRCUIT RANGE/PERFORMANCE —, Diagnostic Procedure with Diagnostic Trouble Code (DTC).>
P0102	Mass or Volume Air Flow Circuit Low Input	<Ref. to EN(STi)-91, DTC P0102 — MASS OR VOLUME AIR FLOW CIRCUIT LOW INPUT —, Diagnostic Procedure with Diagnostic Trouble Code (DTC).>
P0103	Mass or Volume Air Flow Circuit High Input	<Ref. to EN(STi)-94, DTC P0103 — MASS OR VOLUME AIR FLOW CIRCUIT HIGH INPUT —, Diagnostic Procedure with Diagnostic Trouble Code (DTC).>
P0107	Manifold Absolute Pressure/Barometric Pressure Circuit Low Input	<Ref. to EN(STi)-96, DTC P0107 — MANIFOLD ABSOLUTE PRESSURE/BAROMETRIC PRESSURE CIRCUIT LOW INPUT —, Diagnostic Procedure with Diagnostic Trouble Code (DTC).>
P0108	Manifold Absolute Pressure/Barometric Pressure Circuit High Input	<Ref. to EN(STi)-98, DTC P0108 — MANIFOLD ABSOLUTE PRESSURE/BAROMETRIC PRESSURE CIRCUIT HIGH INPUT —, Diagnostic Procedure with Diagnostic Trouble Code (DTC).>
P0111	Intake Air Temperature Circuit Range/Performance	<Ref. to EN(STi)-100, DTC P0111 — INTAKE AIR TEMPERATURE CIRCUIT RANGE/PERFORMANCE —, Diagnostic Procedure with Diagnostic Trouble Code (DTC).>
P0112	Intake Air Temperature Circuit Low Input	<Ref. to EN(STi)-102, DTC P0112 — INTAKE AIR TEMPERATURE CIRCUIT LOW INPUT —, Diagnostic Procedure with Diagnostic Trouble Code (DTC).>
P0113	Intake Air Temperature Circuit High Input	<Ref. to EN(STi)-104, DTC P0113 — INTAKE AIR TEMPERATURE CIRCUIT HIGH INPUT —, Diagnostic Procedure with Diagnostic Trouble Code (DTC).>
P0117	Engine Coolant Temperature Circuit Low Input	<Ref. to EN(STi)-107, DTC P0117 — ENGINE COOLANT TEMPERATURE CIRCUIT LOW INPUT —, Diagnostic Procedure with Diagnostic Trouble Code (DTC).>
P0118	Engine Coolant Temperature Circuit High Input	<Ref. to EN(STi)-109, DTC P0118 — ENGINE COOLANT TEMPERATURE CIRCUIT HIGH INPUT —, Diagnostic Procedure with Diagnostic Trouble Code (DTC).>

# LIST OF DIAGNOSTIC TROUBLE CODE (DTC)

ENGINE (DIAGNOSTICS)

DTC	Item	Index
P0122	Throttle/Pedal Position Sensor/Switch "A" Circuit Low Input	<Ref. to EN(STi)-112, DTC P0122 — THROTTLE/PEDAL POSITION SENSOR/SWITCH "A" CIRCUIT LOW INPUT —, Diagnostic Procedure with Diagnostic Trouble Code (DTC).>
P0123	Throttle/Pedal Position Sensor/Switch "A" Circuit High Input	<Ref. to EN(STi)-115, DTC P0123 — THROTTLE/PEDAL POSITION SENSOR/SWITCH "A" CIRCUIT HIGH INPUT —, Diagnostic Procedure with Diagnostic Trouble Code (DTC).>
P0125	Insufficient Coolant Temperature for Closed Loop Fuel Control	<Ref. to EN(STi)-119, DTC P0125 — INSUFFICIENT COOLANT TEMPERATURE FOR CLOSED LOOP FUEL CONTROL —, Diagnostic Procedure with Diagnostic Trouble Code (DTC).>
P0128	Coolant Thermostat (Coolant Temperature Below Thermostat Regulating Temperature)	<Ref. to EN(STi)-121, DTC P0128 — COOLANT THERMOSTAT (COOLANT TEMPERATURE BELOW THERMOSTAT REGULATING TEMPERATURE) —, Diagnostic Procedure with Diagnostic Trouble Code (DTC).>
P0129	Atmospheric Pressure Sensor Circuit Range/Performance	<Ref. to EN(STi)-122, DTC P0129 — ATMOSPHERIC PRESSURE SENSOR CIRCUIT RANGE/PERFORMANCE —, Diagnostic Procedure with Diagnostic Trouble Code (DTC).>
P0131	O <sub>2</sub> Sensor Circuit Low Voltage (Bank 1 Sensor 1)	<Ref. to EN(STi)-123, DTC P0131 — O <sub>2</sub> SENSOR CIRCUIT LOW VOLTAGE (BANK 1 SENSOR 1) —, Diagnostic Procedure with Diagnostic Trouble Code (DTC).>
P0132	O <sub>2</sub> Sensor Circuit High Voltage (Bank 1 Sensor 1)	<Ref. to EN(STi)-125, DTC P0132 — O <sub>2</sub> SENSOR CIRCUIT HIGH VOLTAGE (BANK 1 SENSOR 1) —, Diagnostic Procedure with Diagnostic Trouble Code (DTC).>
P0133	O <sub>2</sub> Sensor Circuit Slow Response (Bank 1 Sensor 1)	<Ref. to EN(STi)-127, DTC P0133 — O <sub>2</sub> SENSOR CIRCUIT SLOW RESPONSE (BANK 1 SENSOR 1) —, Diagnostic Procedure with Diagnostic Trouble Code (DTC).>
P0134	O <sub>2</sub> Sensor Circuit No Activity Detected (Bank 1 Sensor 1)	<Ref. to EN(STi)-129, DTC P0134 — O <sub>2</sub> SENSOR CIRCUIT NO ACTIVITY DETECTED (BANK 1 SENSOR 1) —, Diagnostic Procedure with Diagnostic Trouble Code (DTC).>
P0137	O <sub>2</sub> Sensor Circuit Low Voltage (Bank 1 Sensor 2)	<Ref. to EN(STi)-131, DTC P0137 — O <sub>2</sub> SENSOR CIRCUIT LOW VOLTAGE (BANK 1 SENSOR 2) —, Diagnostic Procedure with Diagnostic Trouble Code (DTC).>
P0138	O <sub>2</sub> Sensor Circuit High Voltage (Bank 1 Sensor 2)	<Ref. to EN(STi)-134, DTC P0138 — O <sub>2</sub> SENSOR CIRCUIT HIGH VOLTAGE (BANK 1 SENSOR 2) —, Diagnostic Procedure with Diagnostic Trouble Code (DTC).>
P0139	O <sub>2</sub> Sensor Circuit Slow Response (Bank 1 Sensor 2)	<Ref. to EN(STi)-137, DTC P0139 — O <sub>2</sub> SENSOR CIRCUIT SLOW RESPONSE (BANK 1 SENSOR 2) —, Diagnostic Procedure with Diagnostic Trouble Code (DTC).>
P0171	System too Lean (Bank 1)	<Ref. to EN(STi)-138, DTC P0171 — SYSTEM TOO LEAN (BANK 1) —, Diagnostic Procedure with Diagnostic Trouble Code (DTC).>
P0172	System too Rich (Bank 1)	<Ref. to EN(STi)-139, DTC P0172 — SYSTEM TOO RICH (BANK 1) —, Diagnostic Procedure with Diagnostic Trouble Code (DTC).>
P0181	Fuel Temperature Sensor "A" Circuit Range/Performance	<Ref. to EN(STi)-142, DTC P0181 — FUEL TEMPERATURE SENSOR "A" CIRCUIT RANGE/PERFORMANCE —, Diagnostic Procedure with Diagnostic Trouble Code (DTC).>
P0182	Fuel Temperature Sensor "A" Circuit Low Input	<Ref. to EN(STi)-144, DTC P0182 — FUEL TEMPERATURE SENSOR "A" CIRCUIT LOW INPUT —, Diagnostic Procedure with Diagnostic Trouble Code (DTC).>
P0183	Fuel Temperature Sensor "A" Circuit High Input	<Ref. to EN(STi)-146, DTC P0183 — FUEL TEMPERATURE SENSOR "A" CIRCUIT HIGH INPUT —, Diagnostic Procedure with Diagnostic Trouble Code (DTC).>
P0222	Throttle/Pedal Position Sensor/Switch "B" Circuit Low Input	<Ref. to EN(STi)-149, DTC P0222 — THROTTLE/PEDAL POSITION SENSOR/SWITCH "b" CIRCUIT LOW INPUT —, Diagnostic Procedure with Diagnostic Trouble Code (DTC).>
P0223	Throttle/Pedal Position Sensor/Switch "B" Circuit High Input	<Ref. to EN(STi)-152, DTC P0223 — THROTTLE/PEDAL POSITION SENSOR/SWITCH "b" CIRCUIT HIGH INPUT —, Diagnostic Procedure with Diagnostic Trouble Code (DTC).>
P0230	Fuel Pump Primary Circuit	<Ref. to EN(STi)-156, DTC P0230 — FUEL PUMP PRIMARY CIRCUIT —, Diagnostic Procedure with Diagnostic Trouble Code (DTC).>

# LIST OF DIAGNOSTIC TROUBLE CODE (DTC)

## ENGINE (DIAGNOSTICS)

DTC	Item	Index
P0244	Turbo/Super Charger Wastegate Solenoid "A" Range/Performance	<Ref. to EN(STi)-159, DTC P0244 — TURBO/SUPER CHARGER WASTEGATE SOLENOID "A" RANGE/PERFORMANCE —, Diagnostic Procedure with Diagnostic Trouble Code (DTC).>
P0245	Turbo/Super Charger Wastegate Solenoid "A" Low	<Ref. to EN(STi)-161, DTC P0245 — TURBO/SUPER CHARGER WASTEGATE SOLENOID "A" LOW —, Diagnostic Procedure with Diagnostic Trouble Code (DTC).>
P0246	Turbo/Super Charger Wastegate Solenoid "A" High	<Ref. to EN(STi)-163, DTC P0246 — TURBO/SUPER CHARGER WASTEGATE SOLENOID "A" HIGH —, Diagnostic Procedure with Diagnostic Trouble Code (DTC).>
P0301	Cylinder 1 misfire detected	<Ref. to EN(STi)-164, DTC P0301 — CYLINDER 1 MISFIRE DETECTED —, Diagnostic Procedure with Diagnostic Trouble Code (DTC).>
P0302	Cylinder 2 misfire detected	<Ref. to EN(STi)-164, DTC P0302 — CYLINDER 2 MISFIRE DETECTED —, Diagnostic Procedure with Diagnostic Trouble Code (DTC).>
P0303	Cylinder 3 misfire detected	<Ref. to EN(STi)-164, DTC P0303 — CYLINDER 3 MISFIRE DETECTED —, Diagnostic Procedure with Diagnostic Trouble Code (DTC).>
P0304	Cylinder 4 misfire detected	<Ref. to EN(STi)-165, DTC P0304 — CYLINDER 4 MISFIRE DETECTED —, Diagnostic Procedure with Diagnostic Trouble Code (DTC).>
P0327	Knock Sensor 1 Circuit Low Input (Bank 1 or Single Sensor)	<Ref. to EN(STi)-170, DTC P0327 — KNOCK SENSOR 1 CIRCUIT LOW INPUT (BANK 1 OR SINGLE SENSOR) —, Diagnostic Procedure with Diagnostic Trouble Code (DTC).>
P0328	Knock Sensor 1 Circuit High Input (Bank 1 or Single Sensor)	<Ref. to EN(STi)-172, DTC P0328 — KNOCK SENSOR 1 CIRCUIT HIGH INPUT (BANK 1 OR SINGLE SENSOR) —, Diagnostic Procedure with Diagnostic Trouble Code (DTC).>
P0335	Crankshaft Position Sensor "A" Circuit	<Ref. to EN(STi)-174, DTC P0335 — CRANKSHAFT POSITION SENSOR "A" CIRCUIT —, Diagnostic Procedure with Diagnostic Trouble Code (DTC).>
P0336	Crankshaft Position Sensor "A" Circuit Range/Performance	<Ref. to EN(STi)-176, DTC P0336 — CRANKSHAFT POSITION SENSOR "A" CIRCUIT RANGE/PERFORMANCE —, Diagnostic Procedure with Diagnostic Trouble Code (DTC).>
P0340	Camshaft Position Sensor "A" Circuit (Bank 1 or Single Sensor)	<Ref. to EN(STi)-178, DTC P0340 — CAMSHAFT POSITION SENSOR "A" CIRCUIT (BANK 1 OR SINGLE SENSOR) —, Diagnostic Procedure with Diagnostic Trouble Code (DTC).>
P0345	Camshaft Position Sensor "A" Circuit (Bank 2)	<Ref. to EN(STi)-180, DTC P0345 — CAMSHAFT POSITION SENSOR "A" CIRCUIT (BANK 2) —, Diagnostic Procedure with Diagnostic Trouble Code (DTC).>
P0420	Catalyst System Efficiency Below Threshold (Bank 1)	<Ref. to EN(STi)-182, DTC P0420 — CATALYST SYSTEM EFFICIENCY BELOW THRESHOLD (BANK 1) —, Diagnostic Procedure with Diagnostic Trouble Code (DTC).>
P0442	Evaporative Emission Control System Leak Detected (small leak)	<Ref. to EN(STi)-184, DTC P0442 — EVAPORATIVE EMISSION CONTROL SYSTEM LEAK DETECTED (SMALL LEAK) —, Diagnostic Procedure with Diagnostic Trouble Code (DTC).>
P0447	Evaporative Emission Control System Vent Control Circuit Open	<Ref. to EN(STi)-188, DTC P0447 — EVAPORATIVE EMISSION CONTROL SYSTEM VENT CONTROL CIRCUIT OPEN —, Diagnostic Procedure with Diagnostic Trouble Code (DTC).>
P0448	Evaporative Emission Control System Vent Control Circuit Shorted	<Ref. to EN(STi)-191, DTC P0448 — EVAPORATIVE EMISSION CONTROL SYSTEM VENT CONTROL CIRCUIT SHORTED —, Diagnostic Procedure with Diagnostic Trouble Code (DTC).>
P0451	Evaporative Emission Control System Pressure Sensor Range/Performance	<Ref. to EN(STi)-193, DTC P0451 — EVAPORATIVE EMISSION CONTROL SYSTEM PRESSURE SENSOR RANGE/PERFORMANCE —, Diagnostic Procedure with Diagnostic Trouble Code (DTC).>
P0452	Evaporative Emission Control System Pressure Sensor Low Input	<Ref. to EN(STi)-195, DTC P0452 — EVAPORATIVE EMISSION CONTROL SYSTEM PRESSURE SENSOR LOW INPUT —, Diagnostic Procedure with Diagnostic Trouble Code (DTC).>
P0453	Evaporative Emission Control System Pressure Sensor High Input	<Ref. to EN(STi)-198, DTC P0453 — EVAPORATIVE EMISSION CONTROL SYSTEM PRESSURE SENSOR HIGH INPUT —, Diagnostic Procedure with Diagnostic Trouble Code (DTC).>

# LIST OF DIAGNOSTIC TROUBLE CODE (DTC)

ENGINE (DIAGNOSTICS)

DTC	Item	Index
P0456	Evaporative Emission Control System Leak Detected (very small leak)	<Ref. to EN(STi)-201, DTC P0456 — EVAPORATIVE EMISSION CONTROL SYSTEM LEAK DETECTED (VERY SMALL LEAK) —, Diagnostic Procedure with Diagnostic Trouble Code (DTC).>
P0457	Evaporative Emission Control System Leak Detected (fuel cap loose/off)	<Ref. to EN(STi)-205, DTC P0457 — EVAPORATIVE EMISSION CONTROL SYSTEM LEAK DETECTED (FUEL CAP LOOSE/OFF) —, Diagnostic Procedure with Diagnostic Trouble Code (DTC).>
P0458	Evaporative Emission Control System Purge Control Valve Circuit Low	<Ref. to EN(STi)-209, DTC P0458 — EVAPORATIVE EMISSION CONTROL SYSTEM PURGE CONTROL VALVE CIRCUIT LOW —, Diagnostic Procedure with Diagnostic Trouble Code (DTC).>
P0459	Evaporative Emission Control System Purge Control Valve Circuit High	<Ref. to EN(STi)-211, DTC P0459 — EVAPORATIVE EMISSION CONTROL SYSTEM PURGE CONTROL VALVE CIRCUIT HIGH —, Diagnostic Procedure with Diagnostic Trouble Code (DTC).>
P0461	Fuel Level Sensor Circuit Range/Performance	<Ref. to EN(STi)-213, DTC P0461 — FUEL LEVEL SENSOR CIRCUIT RANGE/PERFORMANCE —, Diagnostic Procedure with Diagnostic Trouble Code (DTC).>
P0462	Fuel Level Sensor Circuit Low Input	<Ref. to EN(STi)-216, DTC P0462 — FUEL LEVEL SENSOR CIRCUIT LOW INPUT —, Diagnostic Procedure with Diagnostic Trouble Code (DTC).>
P0463	Fuel Level Sensor Circuit High Input	<Ref. to EN(STi)-220, DTC P0463 — FUEL LEVEL SENSOR CIRCUIT HIGH INPUT —, Diagnostic Procedure with Diagnostic Trouble Code (DTC).>
P0464	Fuel Level Sensor Circuit Intermittent	<Ref. to EN(STi)-224, DTC P0464 — FUEL LEVEL SENSOR CIRCUIT INTERMITTENT —, Diagnostic Procedure with Diagnostic Trouble Code (DTC).>
P0483	Cooling Fan Rationality Check	<Ref. to EN(STi)-227, DTC P0483 — COOLING FAN RATIONALITY CHECK —, Diagnostic Procedure with Diagnostic Trouble Code (DTC).>
P0502	Vehicle Speed Sensor Circuit Low Input	<Ref. to EN(STi)-230, DTC P0502 — VEHICLE SPEED SENSOR CIRCUIT LOW INPUT —, Diagnostic Procedure with Diagnostic Trouble Code (DTC).>
P0503	Vehicle Speed Sensor Intermittent/Erratic/High	<Ref. to EN(STi)-232, DTC P0503 — VEHICLE SPEED SENSOR INTERMITTENT/ERRATIC/HIGH —, Diagnostic Procedure with Diagnostic Trouble Code (DTC).>
P0506	Idle Control System RPM Lower Than Expected	<Ref. to EN(STi)-234, DTC P0506 — IDLE CONTROL SYSTEM RPM LOWER THAN EXPECTED —, Diagnostic Procedure with Diagnostic Trouble Code (DTC).>
P0507	Idle Control System RPM Higher Than Expected	<Ref. to EN(STi)-237, DTC P0507 — IDLE CONTROL SYSTEM RPM HIGHER THAN EXPECTED —, Diagnostic Procedure with Diagnostic Trouble Code (DTC).>
P0512	Starter Request Circuit	<Ref. to EN(STi)-240, DTC P0512 — STARTER REQUEST CIRCUIT —, Diagnostic Procedure with Diagnostic Trouble Code (DTC).>
P0519	Idle Control System Malfunction (Fail-Safe)	<Ref. to EN(STi)-243, DTC P0519 — IDLE CONTROL SYSTEM MALFUNCTION (FAIL-SAFE) —, Diagnostic Procedure with Diagnostic Trouble Code (DTC).>
P0604	Internal Control Module Random Access Memory (RAM) Error	<Ref. to EN(STi)-246, DTC P0604 — INTERNAL CONTROL MODULE RANDOM ACCESS MEMORY (RAM) ERROR —, Diagnostic Procedure with Diagnostic Trouble Code (DTC).>
P0605	Internal Control Module Read Only Memory (ROM) Error	<Ref. to EN(STi)-248, DTC P0605 — INTERNAL CONTROL MODULE READ ONLY MEMORY (ROM) ERROR —, Diagnostic Procedure with Diagnostic Trouble Code (DTC).>
P0607	Control Module Performance	<Ref. to EN(STi)-249, DTC P0607 — CONTROL MODULE PERFORMANCE —, Diagnostic Procedure with Diagnostic Trouble Code (DTC).>
P0638	Throttle Actuator Control Range/Performance (Bank 1)	<Ref. to EN(STi)-251, DTC P0638 — THROTTLE ACTUATOR CONTROL RANGE/PERFORMANCE (BANK 1) —, Diagnostic Procedure with Diagnostic Trouble Code (DTC).>
P0691	Cooling Fan 1 Control Circuit Low	<Ref. to EN(STi)-252, DTC P0691 — COOLING FAN 1 CONTROL CIRCUIT LOW —, Diagnostic Procedure with Diagnostic Trouble Code (DTC).>

# LIST OF DIAGNOSTIC TROUBLE CODE (DTC)

## ENGINE (DIAGNOSTICS)

DTC	Item	Index
P0692	Cooling Fan 1 Control Circuit High	<Ref. to EN(STi)-255, DTC P0692 — COOLING FAN 1 CONTROL CIRCUIT HIGH —, Diagnostic Procedure with Diagnostic Trouble Code (DTC).>
P0851	Neutral Switch Input Circuit Low	<Ref. to EN(STi)-258, DTC P0851 — NEUTRAL SWITCH INPUT CIRCUIT LOW —, Diagnostic Procedure with Diagnostic Trouble Code (DTC).>
P0852	Neutral Switch Input Circuit High	<Ref. to EN(STi)-260, DTC P0852 — NEUTRAL SWITCH INPUT CIRCUIT HIGH —, Diagnostic Procedure with Diagnostic Trouble Code (DTC).>
P1086	Tumble Generated Valve Position Sensor 2 Circuit Low	<Ref. to EN(STi)-262, DTC P1086 — TUMBLE GENERATED VALVE POSITION SENSOR 2 CIRCUIT LOW —, Diagnostic Procedure with Diagnostic Trouble Code (DTC).>
P1087	Tumble Generated Valve Position Sensor 2 Circuit High	<Ref. to EN(STi)-265, DTC P1087 — TUMBLE GENERATED VALVE POSITION SENSOR 2 CIRCUIT HIGH —, Diagnostic Procedure with Diagnostic Trouble Code (DTC).>
P1088	Tumble Generated Valve Position Sensor 1 Circuit Low	<Ref. to EN(STi)-267, DTC P1088 — TUMBLE GENERATED VALVE POSITION SENSOR 1 CIRCUIT LOW —, Diagnostic Procedure with Diagnostic Trouble Code (DTC).>
P1089	Tumble Generated Valve Position Sensor 1 Circuit High	<Ref. to EN(STi)-270, DTC P1089 — TUMBLE GENERATED VALVE POSITION SENSOR 1 CIRCUIT HIGH —, Diagnostic Procedure with Diagnostic Trouble Code (DTC).>
P1090	Tumble Generated Valve System 1 (Valve Open)	<Ref. to EN(STi)-272, DTC P1090 — TUMBLE GENERATED VALVE SYSTEM 1 (VALVE OPEN) —, Diagnostic Procedure with Diagnostic Trouble Code (DTC).>
P1091	Tumble Generated Valve System 1 (Valve Close)	<Ref. to EN(STi)-272, DTC P1091 — TUMBLE GENERATED VALVE SYSTEM 1 (VALVE CLOSE) —, Diagnostic Procedure with Diagnostic Trouble Code (DTC).>
P1092	Tumble Generated Valve System 2 (Valve Open)	<Ref. to EN(STi)-273, DTC P1092 — TUMBLE GENERATED VALVE SYSTEM 2 (VALVE OPEN) —, Diagnostic Procedure with Diagnostic Trouble Code (DTC).>
P1093	Tumble Generated Valve System 2 (Valve Close)	<Ref. to EN(STi)-273, DTC P1093 — TUMBLE GENERATED VALVE SYSTEM 2 (VALVE CLOSE) —, Diagnostic Procedure with Diagnostic Trouble Code (DTC).>
P1094	Tumble Generated Valve Signal 1 Circuit Malfunction (Open)	<Ref. to EN(STi)-274, DTC P1094 — TUMBLE GENERATED VALVE SIGNAL 1 CIRCUIT MALFUNCTION (OPEN) —, Diagnostic Procedure with Diagnostic Trouble Code (DTC).>
P1095	Tumble Generated Valve Signal 1 Circuit Malfunction (Short)	<Ref. to EN(STi)-276, DTC P1095 — TUMBLE GENERATED VALVE SIGNAL 1 CIRCUIT MALFUNCTION (SHORT) —, Diagnostic Procedure with Diagnostic Trouble Code (DTC).>
P1096	Tumble Generated Valve Signal 2 Circuit Malfunction (Open)	<Ref. to EN(STi)-278, DTC P1096 — TUMBLE GENERATED VALVE SIGNAL 2 CIRCUIT MALFUNCTION (OPEN) —, Diagnostic Procedure with Diagnostic Trouble Code (DTC).>
P1097	Tumble Generated Valve Signal 2 Circuit Malfunction (Short)	<Ref. to EN(STi)-280, DTC P1097 — TUMBLE GENERATED VALVE SIGNAL 2 CIRCUIT MALFUNCTION (SHORT) —, Diagnostic Procedure with Diagnostic Trouble Code (DTC).>
P1110	Atmospheric Pressure Sensor Circuit Malfunction (Low Input)	<Ref. to EN(STi)-282, DTC P1110 — ATMOSPHERIC PRESSURE SENSOR CIRCUIT MALFUNCTION (LOW INPUT) —, Diagnostic Procedure with Diagnostic Trouble Code (DTC).>
P1111	Atmospheric Pressure Sensor Circuit Malfunction (High Input)	<Ref. to EN(STi)-282, DTC P1111 — ATMOSPHERIC PRESSURE SENSOR CIRCUIT MALFUNCTION (HIGH INPUT) —, Diagnostic Procedure with Diagnostic Trouble Code (DTC).>
P1152	O <sub>2</sub> Sensor Circuit Range/Performance (Low) (Bank1 Sensor1)	<Ref. to EN(STi)-283, DTC P1152 — O <sub>2</sub> SENSOR CIRCUIT RANGE/PERFORMANCE (LOW) (BANK1 SENSOR1) —, Diagnostic Procedure with Diagnostic Trouble Code (DTC).>
P1153	O <sub>2</sub> Sensor Circuit Range/Performance (High) (Bank1 Sensor1)	<Ref. to EN(STi)-285, DTC P1153 — O <sub>2</sub> SENSOR CIRCUIT RANGE/PERFORMANCE (HIGH) (BANK1 SENSOR1) —, Diagnostic Procedure with Diagnostic Trouble Code (DTC).>
P1160	Return Spring Failure	<Ref. to EN(STi)-286, DTC P1160 — RETURN SPRING FAILURE —, Diagnostic Procedure with Diagnostic Trouble Code (DTC).>

# LIST OF DIAGNOSTIC TROUBLE CODE (DTC)

ENGINE (DIAGNOSTICS)

DTC	Item	Index
P1400	Fuel Tank Pressure Control Solenoid Valve Circuit Low	<Ref. to EN(STi)-287, DTC P1400 — FUEL TANK PRESSURE CONTROL SOLENOID VALVE CIRCUIT LOW —, Diagnostic Procedure with Diagnostic Trouble Code (DTC).>
P1420	Fuel Tank Pressure Control Sol. Valve Circuit High	<Ref. to EN(STi)-290, DTC P1420 — FUEL TANK PRESSURE CONTROL SOL. VALVE CIRCUIT HIGH —, Diagnostic Procedure with Diagnostic Trouble Code (DTC).>
P1443	Vent Control Solenoid Valve Function Problem	<Ref. to EN(STi)-292, DTC P1443 — VENT CONTROL SOLENOID VALVE FUNCTION PROBLEM —, Diagnostic Procedure with Diagnostic Trouble Code (DTC).>
P1446	Fuel Tank Sensor Control Valve Circuit Low	<Ref. to EN(STi)-294, DTC P1446 — FUEL TANK SENSOR CONTROL VALVE CIRCUIT LOW —, Diagnostic Procedure with Diagnostic Trouble Code (DTC).>
P1447	Fuel Tank Sensor Control Valve Circuit High	<Ref. to EN(STi)-297, DTC P1447 — FUEL TANK SENSOR CONTROL VALVE CIRCUIT HIGH —, Diagnostic Procedure with Diagnostic Trouble Code (DTC).>
P1448	Fuel Tank Sensor Control Valve Range/Performance	<Ref. to EN(STi)-299, DTC P1448 — FUEL TANK SENSOR CONTROL VALVE RANGE/PERFORMANCE —, Diagnostic Procedure with Diagnostic Trouble Code (DTC).>
P1491	Positive Crankcase Ventilation (Blow-by) Function Problem	<Ref. to EN(STi)-301, DTC P1491 — POSITIVE CRANKCASE VENTILATION (BLOW-BY) FUNCTION PROBLEM —, Diagnostic Procedure with Diagnostic Trouble Code (DTC).>
P1518	Starter Switch Circuit Low Input	<Ref. to EN(STi)-303, DTC P1518 — STARTER SWITCH CIRCUIT LOW INPUT —, Diagnostic Procedure with Diagnostic Trouble Code (DTC).>
P1560	Back-Up Voltage Circuit Malfunction	<Ref. to EN(STi)-306, DTC P1560 — BACK-UP VOLTAGE CIRCUIT MALFUNCTION —, Diagnostic Procedure with Diagnostic Trouble Code (DTC).>
P2088	OCV Solenoid Valve Signal A Circuit Open (Bank 1)	<Ref. to EN(STi)-309, DTC P2088 — OCV SOLENOID VALVE SIGNAL A CIRCUIT OPEN (BANK 1) —, Diagnostic Procedure with Diagnostic Trouble Code (DTC).>
P2089	OCV Solenoid Valve Signal A Circuit Short (Bank 1)	<Ref. to EN(STi)-311, DTC P2089 — OCV SOLENOID VALVE SIGNAL A CIRCUIT SHORT (BANK 1) —, Diagnostic Procedure with Diagnostic Trouble Code (DTC).>
P2092	OCV Solenoid Valve Signal A Circuit Open (Bank 2)	<Ref. to EN(STi)-313, DTC P2092 — OCV SOLENOID VALVE SIGNAL A CIRCUIT OPEN (BANK 2) —, Diagnostic Procedure with Diagnostic Trouble Code (DTC).>
P2093	OCV Solenoid Valve Signal A Circuit Short (Bank 2)	<Ref. to EN(STi)-315, DTC P2093 — OCV SOLENOID VALVE SIGNAL A CIRCUIT SHORT (BANK 2) —, Diagnostic Procedure with Diagnostic Trouble Code (DTC).>
P2096	Post Catalyst Fuel Trim System Too Lean Bank 1	<Ref. to EN(STi)-317, DTC P2096 — POST CATALYST FUEL TRIM SYSTEM TOO LEAN BANK 1 —, Diagnostic Procedure with Diagnostic Trouble Code (DTC).>
P2097	Post Catalyst Fuel Trim System Too Rich Bank 1	<Ref. to EN(STi)-321, DTC P2097 — POST CATALYST FUEL TRIM SYSTEM TOO RICH BANK 1 —, Diagnostic Procedure with Diagnostic Trouble Code (DTC).>
P2101	Throttle Actuator Control Motor Circuit Range/Performance	<Ref. to EN(STi)-325, DTC P2101 — THROTTLE ACTUATOR CONTROL MOTOR CIRCUIT RANGE/PERFORMANCE —, Diagnostic Procedure with Diagnostic Trouble Code (DTC).>
P2102	Throttle Actuator Control Motor Circuit Low	<Ref. to EN(STi)-332, DTC P2102 — THROTTLE ACTUATOR CONTROL MOTOR CIRCUIT LOW —, Diagnostic Procedure with Diagnostic Trouble Code (DTC).>
P2103	Throttle Actuator Control Motor Circuit High	<Ref. to EN(STi)-335, DTC P2103 — THROTTLE ACTUATOR CONTROL MOTOR CIRCUIT HIGH —, Diagnostic Procedure with Diagnostic Trouble Code (DTC).>
P2109	Throttle/Pedal Position Sensor A Minimum Stop Performance	<Ref. to EN(STi)-336, DTC P2109 — THROTTLE/PEDAL POSITION SENSOR A MINIMUM STOP PERFORMANCE —, Diagnostic Procedure with Diagnostic Trouble Code (DTC).>

## LIST OF DIAGNOSTIC TROUBLE CODE (DTC)

### ENGINE (DIAGNOSTICS)

DTC	Item	Index
P2122	Throttle/Pedal Position Sensor/ Switch "D" Circuit Low Input	<Ref. to EN(STi)-337, DTC P2122 — THROTTLE/PEDAL POSITION SENSOR/SWITCH "d" CIRCUIT LOW INPUT —, Diagnostic Procedure with Diagnostic Trouble Code (DTC).>
P2123	Throttle/Pedal Position Sensor/ Switch "D" Circuit High Input	<Ref. to EN(STi)-340, DTC P2123 — THROTTLE/PEDAL POSITION SENSOR/SWITCH "D" CIRCUIT HIGH INPUT —, Diagnostic Procedure with Diagnostic Trouble Code (DTC).>
P2127	Throttle/Pedal Position Sensor/ Switch "E" Circuit Low Input	<Ref. to EN(STi)-343, DTC P2127 — THROTTLE/PEDAL POSITION SENSOR/SWITCH "E" CIRCUIT LOW INPUT —, Diagnostic Procedure with Diagnostic Trouble Code (DTC).>
P2128	Throttle/Pedal Position Sensor/ Switch "E" Circuit High Input	<Ref. to EN(STi)-346, DTC P2128 — THROTTLE/PEDAL POSITION SENSOR/SWITCH "E" CIRCUIT HIGHT INPUT —, Diagnostic Procedure with Diagnostic Trouble Code (DTC).>
P2135	Throttle/Pedal Position Sensor/ Switch "A"/"B" Voltage Rationality	<Ref. to EN(STi)-349, DTC P2135 — THROTTLE/PEDAL POSITION SENSOR/SWITCH "A"/"B" VOLTAGE RATIONALITY —, Diagnostic Procedure with Diagnostic Trouble Code (DTC).>
P2138	Throttle/Pedal Position Sensor/ Switch "D"/"E" Voltage Rationality	<Ref. to EN(STi)-354, DTC P2138 — THROTTLE/PEDAL POSITION SENSOR/SWITCH "D"/"E" VOLTAGE RATIONALITY —, Diagnostic Procedure with Diagnostic Trouble Code (DTC).>



## 18. Diagnostic Procedure with Diagnostic Trouble Code (DTC)

### A: DTC P0011 — “A” CAMSHAFT POSITION-TIMING OVER-ADVANCED OR SYSTEM PERFORMANCE (BANK 1) —

- **DTC DETECTING CONDITION:**
  - Immediately at fault recognition
- **TROUBLE SYMPTOM:**
  - Engine stalls.
  - Erroneous idling

**CAUTION:**

After repair or replacement of faulty parts, conduct Clear Memory Mode <Ref. to EN(STi)-42, OPERATION, Clear Memory Mode.> and Inspection Mode <Ref. to EN(STi)-35, Inspection Mode.>.

Step	Check	Yes	No
1 <b>CHECK ANY OTHER DTC ON DISPLAY.</b>	Is any other DTC displayed?	Inspect the relevant DTC using “List of Diagnostic Trouble Code (DTC)”. <Ref. to EN(STi)-66, List of Diagnostic Trouble Code (DTC).>	Go to step 2.
2 <b>CHECK CURRENT DATA.</b> 1) Start the engine and let it idle. 2) Inspect the AVCS operating angle and variable valve timing solenoid valve duty output using Subaru Select Monitor and OBD-II general scan tool.  NOTE: • Subaru Select Monitor For detailed operation procedure, refer to the “READ CURRENT DATA FOR ENGINE”. <Ref. to EN(STi)-28, Subaru Select Monitor.> • OBD-II general scan tool For detailed operation procedures, refer to the OBD-II General Scan Tool Instruction Manual.	Is the AVCS operating angle more than approx. 0°C and the variable valve timing solenoid valve duty output more than approx. 10%?	Inspect the following items and repair or replace if necessary. <ul style="list-style-type: none"> <li>• Engine oil (amount, contamination)</li> <li>• Oil pipe (clog)</li> <li>• variable valve timing solenoid valve (clog or contamination in oil passage, settling at spring, stuck at valve)</li> <li>• Intake camshaft (sludge, damage at camshaft)</li> <li>• Timing belt (timing mark aligning)</li> </ul>	A temporary malfunction. Conduct the following to clean the oil passage. Replace the engine oil and idle the engine for 5 minutes, then replace the oil filter and engine oil.

# DIAGNOSTIC PROCEDURE WITH DIAGNOSTIC TROUBLE CODE (DTC)

ENGINE (DIAGNOSTICS)

## B: DTC P0021 — “A” CAMSHAFT POSITION-TIMING OVER-ADVANCED OR SYSTEM PERFORMANCE (BANK 2) —

- **DTC DETECTING CONDITION:**
  - Immediately at fault recognition
- **TROUBLE SYMPTOM:**
  - Engine stalls.
  - Erroneous idling

**CAUTION:**

After repair or replacement of faulty parts, conduct Clear Memory Mode <Ref. to EN(STi)-42, OPERATION, Clear Memory Mode.> and Inspection Mode <Ref. to EN(STi)-35, OPERATION, Inspection Mode.>.

Step	Check	Yes	No
1 <b>CHECK ANY OTHER DTC ON DISPLAY.</b>	Is any other DTC displayed?	Inspect the relevant DTC using “List of Diagnostic Trouble Code (DTC)”. <Ref. to EN(STi)-66, List of Diagnostic Trouble Code (DTC).>	Go to step 2.
2 <b>CHECK CURRENT DATA.</b> 1)Start the engine and let it idle. 2)Inspect the AVCS operating angle and variable valve timing solenoid valve duty output using Subaru Select Monitor and OBD-II general scan tool.  NOTE: •Subaru Select Monitor For detailed operation procedure, refer to the “READ CURRENT DATA FOR ENGINE”. <Ref. to EN(STi)-28, Subaru Select Monitor.> •OBD-II general scan tool For detailed operation procedures, refer to the OBD-II General Scan Tool Instruction Manual.	Is the AVCS operating angle more than approx. 0°C and the variable valve timing solenoid valve duty output more than approx. 10%?	Inspect the following items and repair or replace if necessary. • Engine oil (amount, contamination) • Oil pipe (clog) • variable valve timing solenoid valve (clog or contamination in oil passage, settling at spring, stuck at valve) • Intake camshaft (sludge, damage at camshaft) • Timing belt (timing mark aligning)	A temporary malfunction. Conduct the following to clean the oil passage. Replace the engine oil and idle the engine for 5 minutes, then replace the oil filter and engine oil.

# DIAGNOSTIC PROCEDURE WITH DIAGNOSTIC TROUBLE CODE (DTC)

ENGINE (DIAGNOSTICS)

## C: DTC P0030 — HO2S HEATER CONTROL CIRCUIT (BANK 1 SENSOR 1) —

### • DTC DETECTING CONDITION:

- Two consecutive driving cycles with fault
- GENERAL DESCRIPTION <Ref. to GD(STi)-12, DTC P0030 — HO2S HEATER CONTROL CIRCUIT (BANK 1 SENSOR 1) —, Diagnostic Trouble Code (DTC) Detecting Criteria.>

### CAUTION:

After repair or replacement of faulty parts, conduct Clear Memory Mode <Ref. to EN(STi)-42, OPERATION, Clear Memory Mode.> and Inspection Mode <Ref. to EN(STi)-35, OPERATION, Inspection Mode.>.

### • WIRING DIAGRAM:

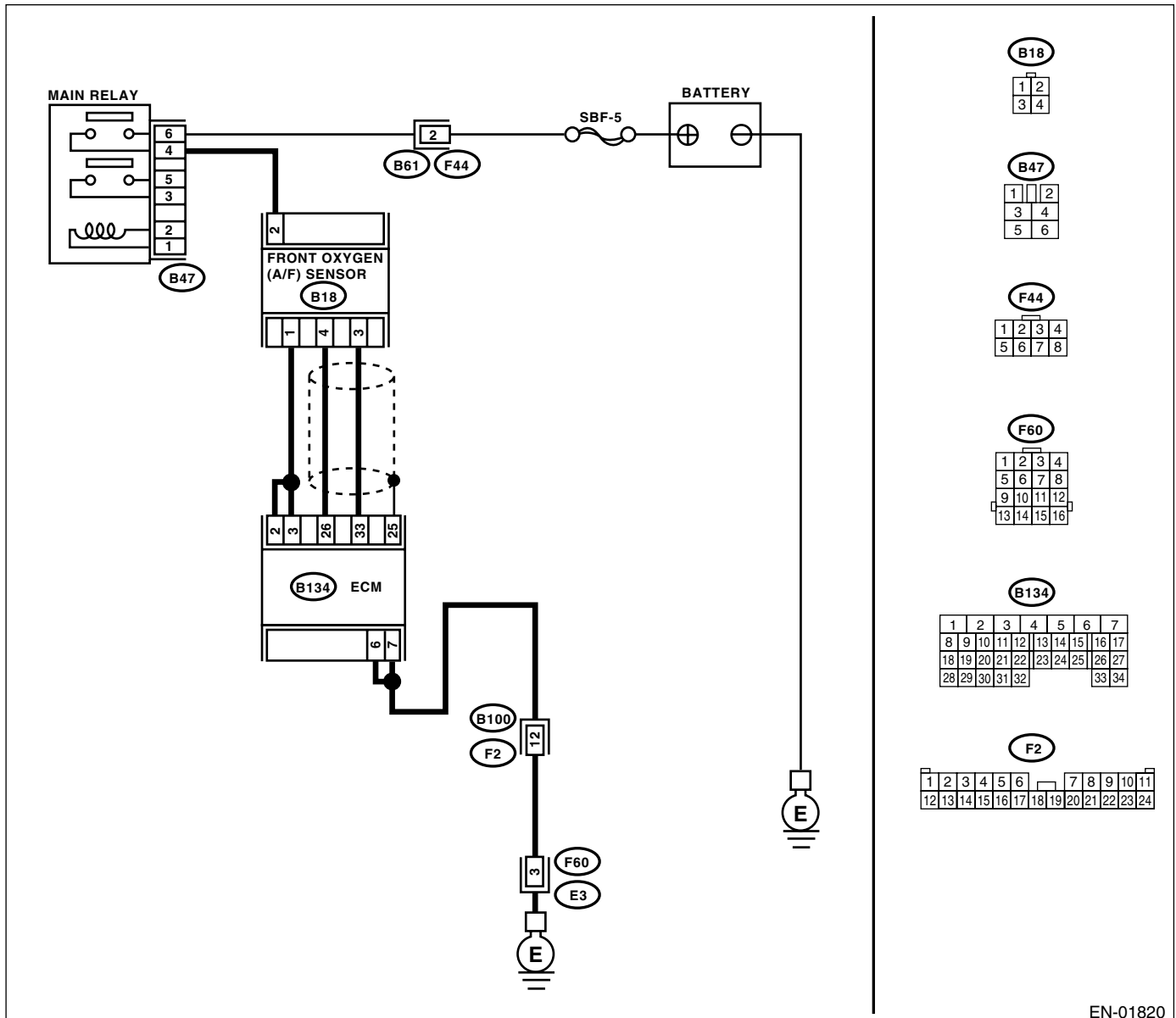

EN-01820

# DIAGNOSTIC PROCEDURE WITH DIAGNOSTIC TROUBLE CODE (DTC)

## ENGINE (DIAGNOSTICS)

Step	Check	Yes	No
<b>1 CHECK HARNESS BETWEEN ECM AND FRONT OXYGEN (A/F) SENSOR CONNECTOR.</b> 1)Start the engine and warm-up engine. 2)Turn the ignition switch to OFF. 3)Disconnect the connectors from ECM and front oxygen (A/F) sensor. 4)Measure the resistance of harness between ECM and front oxygen (A/F) sensor connector. <b>Connector &amp; terminal</b> <b>(B134) No. 5 — (B18) No. 1:</b> <b>(B134) No. 4 — (B18) No. 1:</b>	Is the resistance less than 1 $\Omega$ ?	Go to step 2.	Repair the open circuit in harness between ECM and front oxygen (A/F) sensor connector.
<b>2 CHECK HARNESS BETWEEN ECM AND FRONT OXYGEN (A/F) SENSOR CONNECTOR.</b> Measure the resistance of harness between ECM and front oxygen (A/F) sensor connector. <b>Connector &amp; terminal</b> <b>(B134) No. 19 — (B18) No. 4:</b> <b>(B134) No. 29 — (B18) No. 3:</b>	Is the resistance less than 1 $\Omega$ ?	Go to step 3.	Repair the open circuit in harness between ECM and front oxygen (A/F) sensor connector.
<b>3 CHECK HARNESS BETWEEN ECM AND FRONT OXYGEN (A/F) SENSOR CONNECTOR.</b> Measure the resistance of harness between main relay and front oxygen (A/F) sensor connector. <b>Connector &amp; terminal</b> <b>(B47) No. 4 — (B18) No. 2:</b>	Is the resistance less than 1 $\Omega$ ?	Go to step 4.	Repair the open circuit in harness between ECM and front oxygen (A/F) sensor connector.
<b>4 CHECK FRONT OXYGEN (A/F) SENSOR.</b> Measure the resistance between front oxygen (A/F) sensor connector terminals. <b>Terminals</b> <b>No. 2 — No. 1:</b>	Is the resistance less than 5 $\Omega$ ?	Go to step 5.	Replace the front oxygen (A/F) sensor. <Ref. to FU(STi)-37, Front Oxygen (A/F) Sensor.>
<b>5 CHECK POOR CONTACT.</b> Check the poor contact in ECM and front oxygen (A/F) sensor connector.	Is there poor contact in ECM or front oxygen (A/F) sensor connector?	Repair the poor contact in ECM or front oxygen (A/F) sensor connector.	Replace the front oxygen (A/F) sensor. <Ref. to FU(STi)-37, Front Oxygen (A/F) Sensor.>

# DIAGNOSTIC PROCEDURE WITH DIAGNOSTIC TROUBLE CODE (DTC)

ENGINE (DIAGNOSTICS)

## D: DTC P0031 — HO2S HEATER CONTROL CIRCUIT LOW (BANK 1 SENSOR 1)

### • DTC DETECTING CONDITION:

- Immediately at fault recognition
- GENERAL DESCRIPTION <Ref. to GD(STi)-14, DTC P0031 — HO2S HEATER CONTROL CIRCUIT LOW (BANK 1 SENSOR 1) —, Diagnostic Trouble Code (DTC) Detecting Criteria.>

### CAUTION:

After repair or replacement of faulty parts, conduct Clear Memory Mode <Ref. to EN(STi)-42, OPERATION, Clear Memory Mode.> and Inspection Mode <Ref. to EN(STi)-35, OPERATION, Inspection Mode.>.

### • WIRING DIAGRAM:

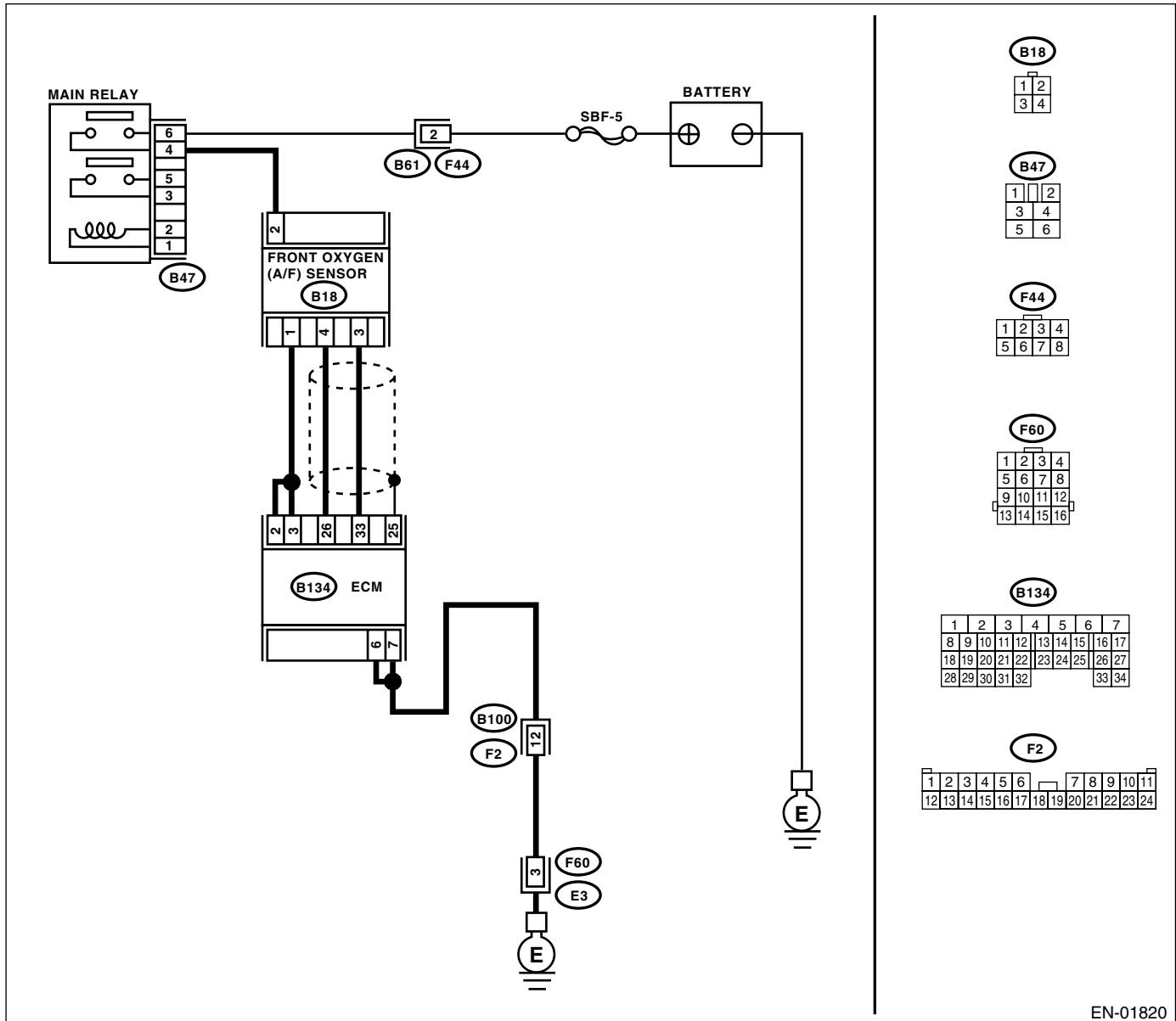

EN-01820

# DIAGNOSTIC PROCEDURE WITH DIAGNOSTIC TROUBLE CODE (DTC)

## ENGINE (DIAGNOSTICS)

Step	Check	Yes	No
<p><b>1 CHECK POWER SUPPLY TO FRONT OXYGEN (A/F) SENSOR.</b>                      1) Turn the ignition switch to OFF.                      2) Disconnect the connector from front oxygen (A/F) sensor.                      3) Turn the ignition switch to ON.                      4) Measure the voltage between front oxygen (A/F) sensor connector and engine ground.  <b>Connector &amp; terminal</b>  <b>(B18) No. 2 (+) — Engine ground (-):</b></p>	<p>Is the voltage more than 10 V?</p>	<p>Go to step 2.</p>	<p>Repair the power supply line.                      NOTE:                      In this case, repair the following:</p> <ul style="list-style-type: none"> <li>• Open circuit in harness between main relay and front oxygen (A/F) sensor connector</li> <li>• Poor contact in front oxygen (A/F) sensor connector</li> <li>• Poor contact in main relay connector</li> </ul>
<p><b>2 CHECK GROUND CIRCUIT OF ECM.</b>                      Measure the resistance of harness between ECM connector and chassis ground.  <b>Connector &amp; terminal</b>  <b>(B134) No. 6 — Chassis ground:</b>  <b>(B134) No. 7 — Chassis ground:</b></p>	<p>Is the resistance less than 5 Ω?</p>	<p>Go to step 3.</p>	<p>Repair the harness and connector.                      NOTE:                      In this case, repair the following:</p> <ul style="list-style-type: none"> <li>• Open circuit in harness between ECM and engine ground cable</li> <li>• Poor contact in ECM connector</li> <li>• Poor contact in coupling connector</li> </ul>
<p><b>3 CHECK CURRENT DATA.</b>                      1) Start the engine.                      2) Read the data of front oxygen (A/F) sensor heater current using Subaru Select Monitor or OBD-II general scan tool.                      NOTE:                      • Subaru Select Monitor                      For detailed operation procedure, refer to the "READ CURRENT DATA FOR ENGINE".                      &lt;Ref. to EN(STi)-28, Subaru Select Monitor.&gt;                      • OBD-II scan tool                      For detailed operation procedures, refer to the OBD-II General Scan Tool Instruction Manual.</p>	<p>Is the current more than 0.2 A?</p>	<p>Repair the poor contact in connector.                      NOTE:                      In this case, repair the following:</p> <ul style="list-style-type: none"> <li>• Poor contact in front oxygen (A/F) sensor connector</li> <li>• Poor contact in ECM connector</li> </ul>	<p>Go to step 4.</p>
<p><b>4 CHECK OUTPUT SIGNAL FROM ECM.</b>                      1) Start and idle the engine.                      2) Measure the voltage between ECM connector and chassis ground.  <b>Connector &amp; terminal</b>  <b>(B134) No. 2 (+) — Chassis ground (-):</b>  <b>(B134) No. 3 (+) — Chassis ground (-):</b></p>	<p>Is the voltage less than 1 V?</p>	<p>Go to step 6.</p>	<p>Go to step 5.</p>
<p><b>5 CHECK OUTPUT SIGNAL FROM ECM.</b>                      Measure the voltage between ECM connector and chassis ground.  <b>Connector &amp; terminal</b>  <b>(B134) No. 2 (+) — Chassis ground (-):</b>  <b>(B134) No. 3 (+) — Chassis ground (-):</b></p>	<p>Shake the ECM harness and connector, while monitoring value of voltage meter. Does the voltage change?</p>	<p>Repair the poor contact in ECM connector.</p>	<p>Go to step 6.</p>

# DIAGNOSTIC PROCEDURE WITH DIAGNOSTIC TROUBLE CODE (DTC)

ENGINE (DIAGNOSTICS)

	Step	Check	Yes	No
6	<b>CHECK FRONT OXYGEN (A/F) SENSOR.</b> 1) Turn the ignition switch to OFF. 2) Measure the resistance between front oxygen (A/F) sensor connector terminals. <b>Terminals</b> <b>No. 2 — No. 1:</b>	Is the resistance less than 10 $\Omega$ ?	Repair the harness and connector. <b>NOTE:</b> In this case, repair the following: <ul style="list-style-type: none"><li>• Open or ground short circuit in harness between front oxygen (A/F) sensor and ECM connector</li><li>• Poor contact in front oxygen (A/F) sensor connector</li><li>• Poor contact in ECM connector</li></ul>	Replace the front oxygen (A/F) sensor. <Ref. to FU(STi)-37, Front Oxygen (A/F) Sensor.>

# DIAGNOSTIC PROCEDURE WITH DIAGNOSTIC TROUBLE CODE (DTC)

ENGINE (DIAGNOSTICS)

## E: DTC P0032 — HO2S HEATER CONTROL CIRCUIT HIGH (BANK 1 SENSOR 1) —

### • DTC DETECTING CONDITION:

- Immediately at fault recognition
- GENERAL DESCRIPTION <Ref. to GD(STi)-16, DTC P0032 — HO2S HEATER CONTROL CIRCUIT HIGH (BANK 1 SENSOR 1) —, Diagnostic Trouble Code (DTC) Detecting Criteria.>

### CAUTION:

After repair or replacement of faulty parts, conduct Clear Memory Mode <Ref. to EN(STi)-42, OPERATION, Clear Memory Mode.> and Inspection Mode <Ref. to EN(STi)-35, OPERATION, Inspection Mode.>.

### • WIRING DIAGRAM:

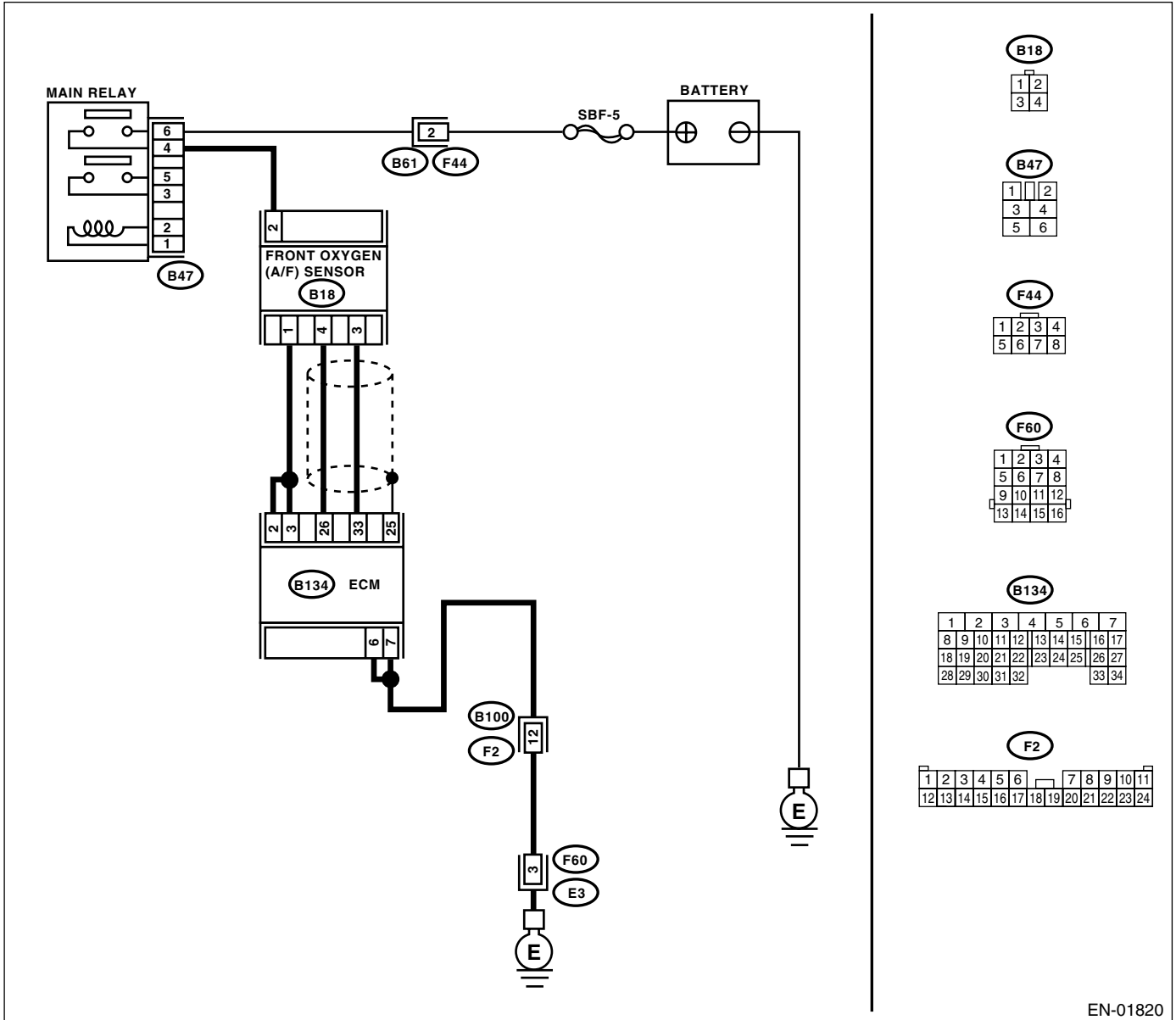

EN-01820



# DIAGNOSTIC PROCEDURE WITH DIAGNOSTIC TROUBLE CODE (DTC)

ENGINE (DIAGNOSTICS)

Step	Check	Yes	No
<p><b>1</b>     <b>CHECK OUTPUT SIGNAL FROM ECM.</b>            1) Turn the ignition switch to ON.            2) Measure the voltage between ECM connector and chassis ground.  <b>Connector &amp; terminal</b>  <b>(B134) No. 2 (+) — Chassis ground (-):</b>  <b>(B134) No. 3 (+) — Chassis ground (-):</b></p>	<p>Is the voltage more than 8 V?</p>	<p>Go to step 3.</p>	<p>Go to step 2.</p>
<p><b>2</b>     <b>CHECK FRONT OXYGEN (A/F) SENSOR HEATER CURRENT.</b>            1) Turn the ignition switch to OFF.            2) Repair the battery short circuit in harness between ECM and front oxygen (A/F) sensor connector.            3) Turn the ignition switch to ON.            4) Read the data of front oxygen (A/F) sensor heater current using Subaru Select Monitor or the OBD-II general scan tool.  <b>NOTE:</b>            •Subaru Select Monitor            For detailed operation procedure, refer to the "READ CURRENT DATA FOR ENGINE".            &lt;Ref. to EN(STi)-28, Subaru Select Monitor.&gt;            •OBD-II general scan tool            For detailed operation procedure, refer to the OBD-II General Scan Tool Instruction Manual.</p>	<p>Is the current more than 2.3 A?</p>	<p>Replace the ECM.            &lt;Ref. to FU(STi)-41, Engine Control Module (ECM).&gt;</p>	<p>END</p>
<p><b>3</b>     <b>CHECK OUTPUT SIGNAL FROM ECM.</b>            Measure the voltage between ECM connector and chassis ground.  <b>Connector &amp; terminal</b>  <b>(B134) No. 2 (+) — Chassis ground (-):</b>  <b>(B134) No. 3 (+) — Chassis ground (-):</b></p>	<p>Shake the ECM harness and connector, while monitoring value of voltage meter. Does the voltage change?</p>	<p>Repair the battery short circuit in harness between ECM and front oxygen (A/F) sensor connector.</p>	<p>END</p>

# DIAGNOSTIC PROCEDURE WITH DIAGNOSTIC TROUBLE CODE (DTC)

ENGINE (DIAGNOSTICS)

## F: DTC P0037 — HO2S HEATER CONTROL CIRCUIT LOW (BANK 1 SENSOR 2)

### • DTC DETECTING CONDITION:

- Immediately at fault recognition
- GENERAL DESCRIPTION <Ref. to GD(STi)-18, DTC P0037 — HO2S HEATER CONTROL CIRCUIT LOW (BANK 1 SENSOR 2) —, Diagnostic Trouble Code (DTC) Detecting Criteria.>

### CAUTION:

After repair or replacement of faulty parts, conduct Clear Memory Mode <Ref. to EN(STi)-42, OPERATION, Clear Memory Mode.> and Inspection Mode <Ref. to EN(STi)-35, OPERATION, Inspection Mode.>.

### • WIRING DIAGRAM:

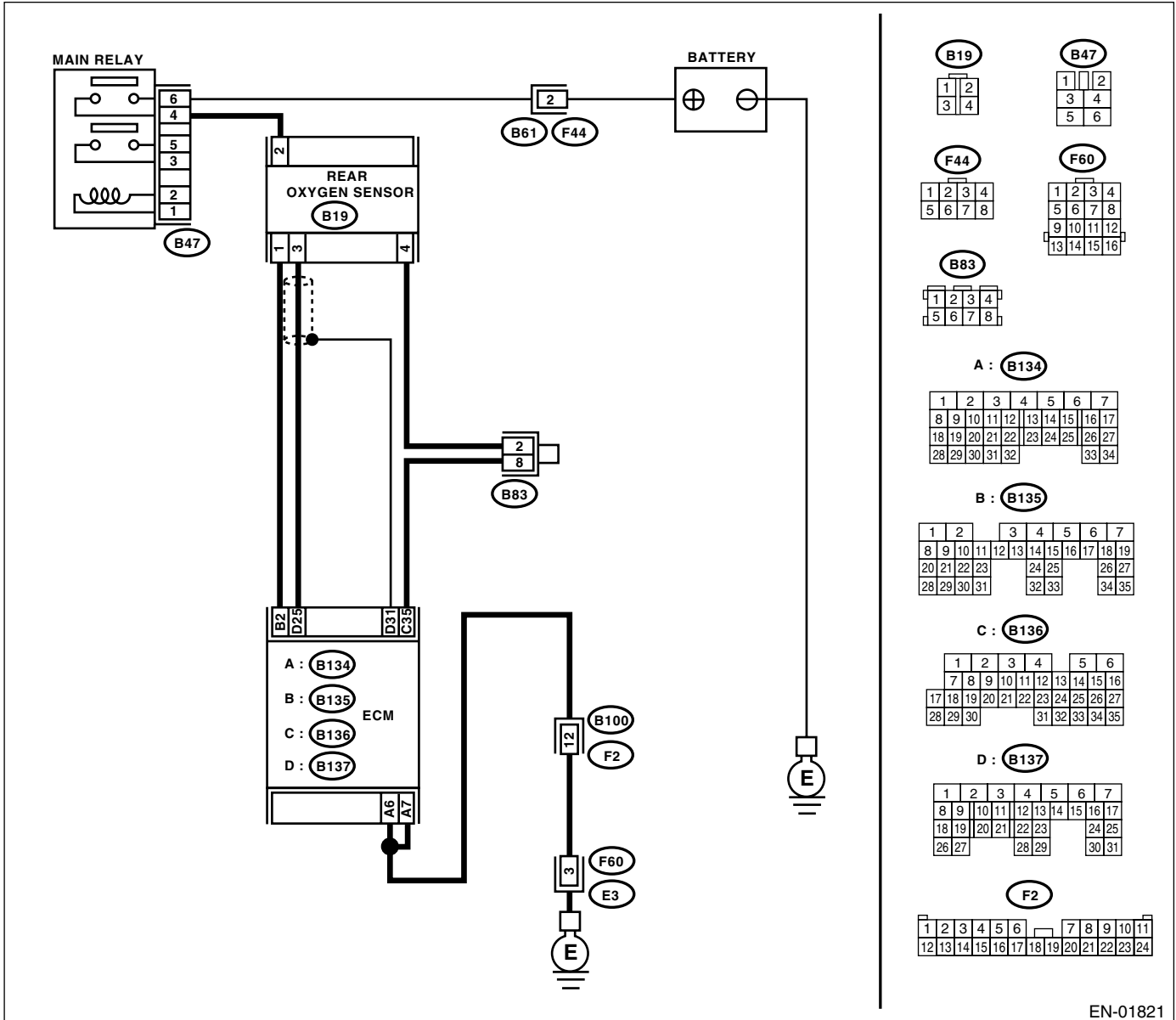

EN-01821

# DIAGNOSTIC PROCEDURE WITH DIAGNOSTIC TROUBLE CODE (DTC)

ENGINE (DIAGNOSTICS)

Step	Check	Yes	No
<p><b>1 CHECK GROUND CIRCUIT OF ECM.</b>                      1) Turn the ignition switch to OFF.                      2) Disconnect the connector from ECM.                      3) Measure the resistance of harness between ECM connector and chassis ground.  <b>Connector &amp; terminal</b>  <b>(B134) No. 6 — Chassis ground:</b>  <b>(B134) No. 7 — Chassis ground:</b></p>	<p>Is the resistance less than 5 Ω?</p>	<p>Go to step 2.</p>	<p>Repair the harness and connector.                      NOTE:                      In this case, repair the following:                      • Open circuit in harness between ECM and engine ground cable                      • Poor contact in ECM connector                      • Poor contact in coupling connector</p>
<p><b>2 CHECK CURRENT DATA.</b>                      1) Start the engine.                      2) Read the data of rear oxygen sensor heater current using Subaru Select Monitor or OBD-II general scan tool.                      NOTE:                      • Subaru Select Monitor                      For detailed operation procedure, refer to the "READ CURRENT DATA FOR ENGINE".                      &lt;Ref. to EN(STi)-28, Subaru Select Monitor.&gt;                      • OBD-II scan tool                      For detailed operation procedures, refer to the OBD-II General Scan Tool Instruction Manual.</p>	<p>Is the current more than 0.2 A?</p>	<p>Repair the connector.                      NOTE:                      In this case, repair the following:                      • Poor contact in rear oxygen sensor connector                      • Poor contact in rear oxygen sensor connecting harness connector                      • Poor contact in ECM connector</p>	<p>Go to step 3.</p>
<p><b>3 CHECK OUTPUT SIGNAL FROM ECM.</b>                      1) Start and idle the engine.                      2) Measure the voltage between ECM connector and chassis ground.  <b>Connector &amp; terminal</b>  <b>(B135) No. 2 (+) — Chassis ground (-):</b></p>	<p>Is the voltage less than 1 V?</p>	<p>Go to step 6.</p>	<p>Go to step 4.</p>
<p><b>4 CHECK OUTPUT SIGNAL FROM ECM.</b>                      Measure the voltage between ECM connector and chassis ground.  <b>Connector &amp; terminal</b>  <b>(B135) No. 2 (+) — Chassis ground (-):</b></p>	<p>Shake the ECM harness and connector, while monitoring value of voltage meter. Does the voltage change?</p>	<p>Repair the poor contact in ECM connector.</p>	<p>Go to step 5.</p>
<p><b>5 CHECK OUTPUT SIGNAL FROM ECM.</b>                      1) Turn the ignition switch to OFF.                      2) Disconnect the connector from rear oxygen sensor.                      3) Measure the voltage between ECM connector and chassis ground.  <b>Connector &amp; terminal</b>  <b>(B135) No. 2 (+) — Chassis ground (-):</b></p>	<p>Is the voltage less than 1 V?</p>	<p>Replace the ECM.                      &lt;Ref. to FU(STi)-41, Engine Control Module (ECM).&gt;</p>	<p>Repair the battery short circuit in harness between ECM and rear oxygen sensor connector. After repair, replace the ECM. &lt;Ref. to FU(STi)-41, Engine Control Module (ECM).&gt;</p>

# DIAGNOSTIC PROCEDURE WITH DIAGNOSTIC TROUBLE CODE (DTC)

ENGINE (DIAGNOSTICS)

Step	Check	Yes	No
<p><b>6</b></p> <p><b>CHECK POWER SUPPLY TO REAR OXYGEN SENSOR.</b></p> <p>1) Turn the ignition switch to OFF.                      2) Disconnect the connector from rear oxygen sensor.                      3) Turn the ignition switch to ON.                      4) Measure the voltage between rear oxygen sensor connector and engine ground or chassis ground.</p> <p><b>Connector &amp; terminal</b>  <b>(B19) No. 2 (+) — Chassis ground (-):</b></p>	<p>Is the voltage more than 10 V?</p>	<p>Go to step 7.</p>	<p>Repair the power supply line.</p> <p><b>NOTE:</b>                      In this case, repair the following:</p> <ul style="list-style-type: none"> <li>• Open circuit in harness between main relay and rear oxygen sensor connector</li> <li>• Poor contact in rear oxygen sensor connector</li> <li>• Poor contact in coupling connector</li> </ul>
<p><b>7</b></p> <p><b>CHECK REAR OXYGEN SENSOR.</b></p> <p>1) Turn the ignition switch to OFF.                      2) Measure the resistance between rear oxygen sensor connector terminals.</p> <p><b>Terminals</b>  <b>No. 1 — No. 2:</b></p>	<p>Is the resistance less than 30 Ω?</p>	<p>Repair the harness and connector.</p> <p><b>NOTE:</b>                      In this case, repair the following:</p> <ul style="list-style-type: none"> <li>• Open circuit in harness between rear oxygen sensor and ECM connector</li> <li>• Poor contact in rear oxygen sensor connector</li> <li>• Poor contact in ECM connector</li> <li>• Poor contact in coupling connector</li> </ul>	<p>Replace the rear oxygen sensor.                      &lt;Ref. to FU(STi)-39, Rear Oxygen Sensor.&gt;</p>

# DIAGNOSTIC PROCEDURE WITH DIAGNOSTIC TROUBLE CODE (DTC)

ENGINE (DIAGNOSTICS)

## G: DTC P0038 — HO2S HEATER CONTROL CIRCUIT HIGH (BANK 1 SENSOR 2) —

### • DTC DETECTING CONDITION:

- Immediately at fault recognition
- GENERAL DESCRIPTION <Ref. to GD(STi)-20, DTC P0038 — HO2S HEATER CONTROL CIRCUIT HIGH (BANK 1 SENSOR 2) —, Diagnostic Trouble Code (DTC) Detecting Criteria.>

### CAUTION:

After repair or replacement of faulty parts, conduct Clear Memory Mode <Ref. to EN(STi)-42, OPERATION, Clear Memory Mode.> and Inspection Mode <Ref. to EN(STi)-35, OPERATION, Inspection Mode.>.

### • WIRING DIAGRAM:

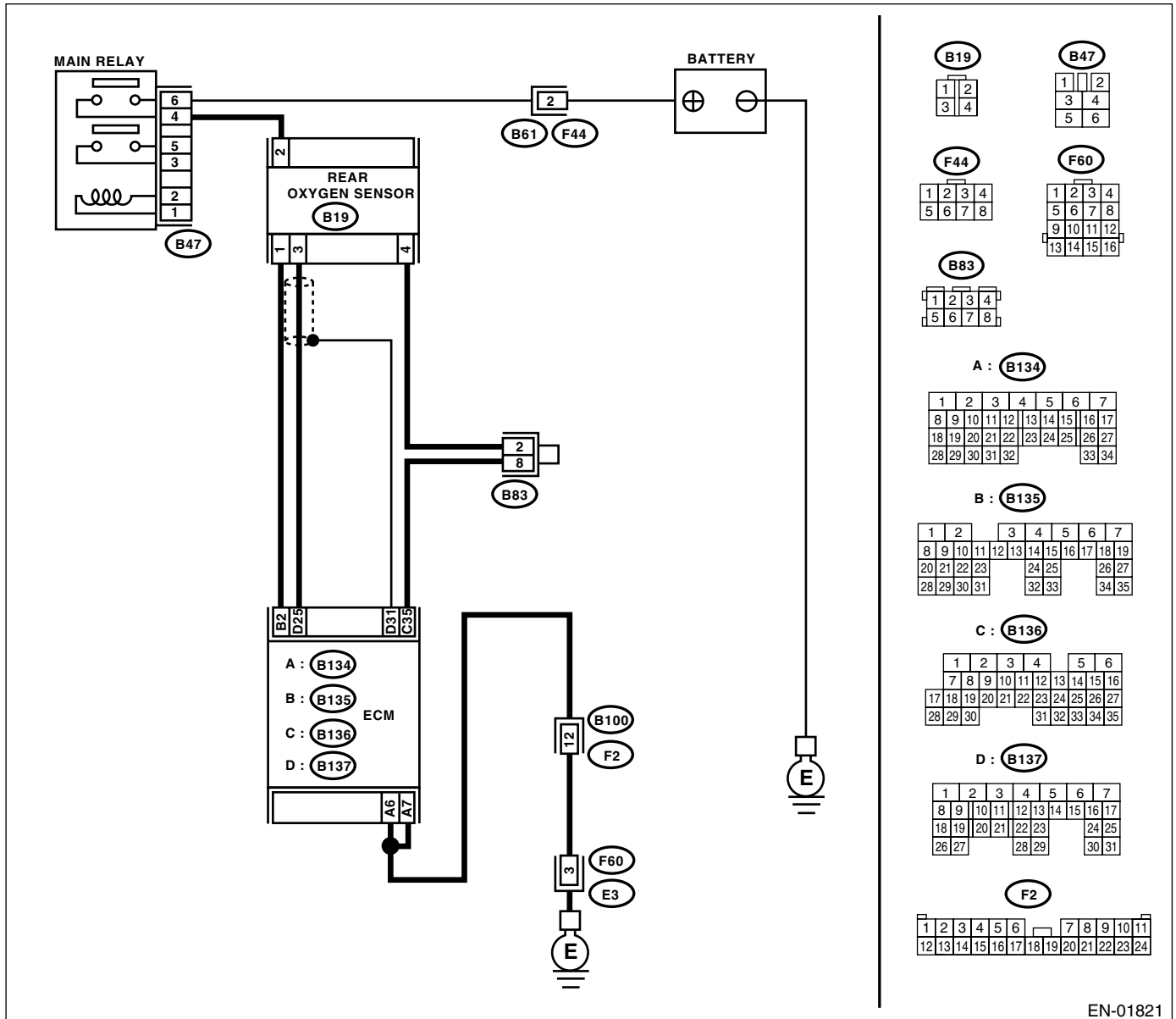

EN-01821

# DIAGNOSTIC PROCEDURE WITH DIAGNOSTIC TROUBLE CODE (DTC)

## ENGINE (DIAGNOSTICS)

	Step	Check	Yes	No
1	<b>CHECK INPUT SIGNAL FOR ECM.</b> 1) Turn the ignition switch to OFF. 2) Measure the voltage between ECM connector and chassis ground. <b>Connector &amp; terminal</b> <b>(B135) No. 2 (+) — Chassis ground (-):</b>	Is the voltage more than 8 V?	Go to step 2.	Go to step 3.
2	<b>CHECK CURRENT DATA.</b> 1) Repair the battery short circuit in harness between ECM and rear oxygen sensor connector. 2) Turn the ignition switch to ON. 3) Read the data of rear oxygen sensor heater current using Subaru Select Monitor or the OBD-II general scan tool.  <b>NOTE:</b> • Subaru Select Monitor For detailed operation procedure, refer to the "READ CURRENT DATA FOR ENGINE". <Ref. to EN(STi)-28, Subaru Select Monitor.> • OBD-II general scan tool For detailed operation procedure, refer to the OBD-II General Scan Tool Instruction Manual.	Is the current more than 7 A?	Replace the ECM. <Ref. to FU(STi)-41, Engine Control Module (ECM).>	END
3	<b>CHECK POOR CONTACT.</b> Check poor contact in ECM connector.	Is there poor contact in ECM connector?	Repair the poor contact in ECM connector.	END

**H: DTC P0068 — MANIFOLD ABSOLUTE PRESSURE/BAROMETRIC PRESSURE CIRCUIT RANGE/PERFORMANCE —**

**• DTC DETECTING CONDITION:**

- Two consecutive driving cycles with fault
- GENERAL DESCRIPTION <Ref. to GD(STi)-22, DTC P0068 — MANIFOLD PRESSURE SENSOR RANGE/PERFORMANCE —, Diagnostic Trouble Code (DTC) Detecting Criteria.>

**• TROUBLE SYMPTOM:**

- Failure of engine to start

**CAUTION:**

After repair or replacement of faulty parts, conduct Clear Memory Mode <Ref. to EN(STi)-42, OPERATION, Clear Memory Mode.> and Inspection Mode <Ref. to EN(STi)-35, OPERATION, Inspection Mode.>.

**• WIRING DIAGRAM:**

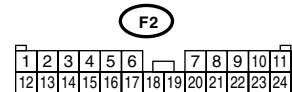
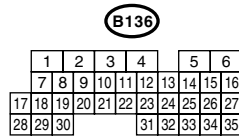
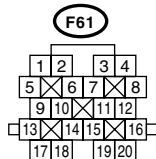
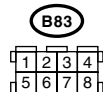
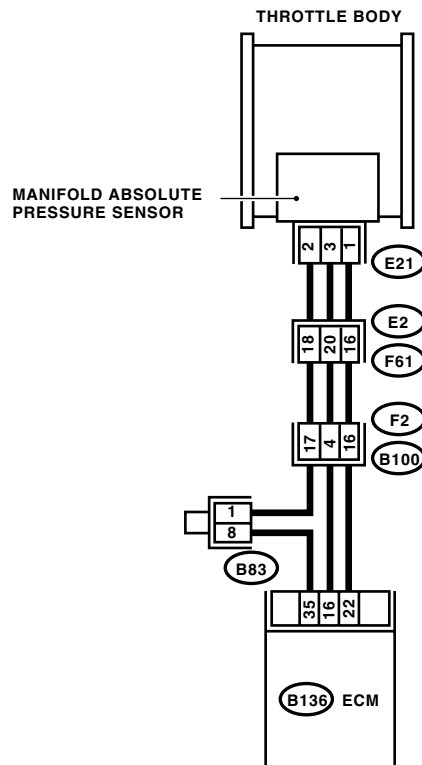

# DIAGNOSTIC PROCEDURE WITH DIAGNOSTIC TROUBLE CODE (DTC)

## ENGINE (DIAGNOSTICS)

	Step	Check	Yes	No
1	<p><b>CHECK IDLE SWITCH SIGNAL.</b></p> <p>1) Turn the ignition switch to ON. 2) Operate the LED operation mode for engine using Subaru Select Monitor.</p> <p>NOTE: • Subaru Select Monitor For detailed operation procedure, refer to the "LED OPERATION MODE FOR ENGINE". &lt;Ref. to EN(STi)-28, Subaru Select Monitor.&gt;</p>	Does the LED of {Idle Switch Signal} come on?	Go to step 2.	<p>Check the throttle position sensor circuit. &lt;Ref. to EN(STi)-349, DTC P2135 — THROTTLE/PEDAL POSITION SENSOR/SWITCH "A"/"B" VOLTAGE RATIO —, Diagnostic Procedure with Diagnostic Trouble Code (DTC).&gt;</p> <p>NOTE: In this case, it is not necessary to inspect DTC P0106.</p>
2	<p><b>CHECK ANY OTHER DTC ON DISPLAY.</b></p>	Is any other DTC displayed?	<p>Inspect the relevant DTC. "List of Diagnostic Trouble Code (DTC)". &lt;Ref. to EN(STi)-66, List of Diagnostic Trouble Code (DTC).&gt;</p> <p>NOTE: In this case, it is not necessary to inspect DTC P0106.</p>	Go to step 3.
3	<p><b>CHECK CONDITION OF MANIFOLD ABSOLUTE PRESSURE SENSOR.</b></p>	Is the manifold absolute pressure sensor installation bolt tightened securely?	Go to step 4.	Tighten the manifold absolute pressure sensor installation bolt securely.
4	<p><b>CHECK CONDITION OF THROTTLE BODY.</b></p>	Is the throttle body installation bolt tightened securely?	Replace the manifold absolute pressure sensor. <Ref. to FU(STi)-31, Manifold Absolute Pressure Sensor.>	Tighten the throttle body installation bolt securely.



# DIAGNOSTIC PROCEDURE WITH DIAGNOSTIC TROUBLE CODE (DTC)

ENGINE (DIAGNOSTICS)

## I: DTC P0101 — MASS OR VOLUME AIR FLOW CIRCUIT RANGE/PERFORMANCE —

### • DTC DETECTING CONDITION:

- Two consecutive driving cycles with fault
- GENERAL DESCRIPTION <Ref. to GD(STi)-24, DTC P0101 — MASS OR VOLUME AIR FLOW CIRCUIT RANGE/PERFORMANCE —, Diagnostic Trouble Code (DTC) Detecting Criteria.>

### • TROUBLE SYMPTOM:

- Erroneous idling
- Engine stalls.
- Poor driving performance

### CAUTION:

After repair or replacement of faulty parts, conduct Clear Memory Mode <Ref. to EN(STi)-42, OPERATION, Clear Memory Mode.> and Inspection Mode <Ref. to EN(STi)-35, OPERATION, Inspection Mode.>.

### • WIRING DIAGRAM:

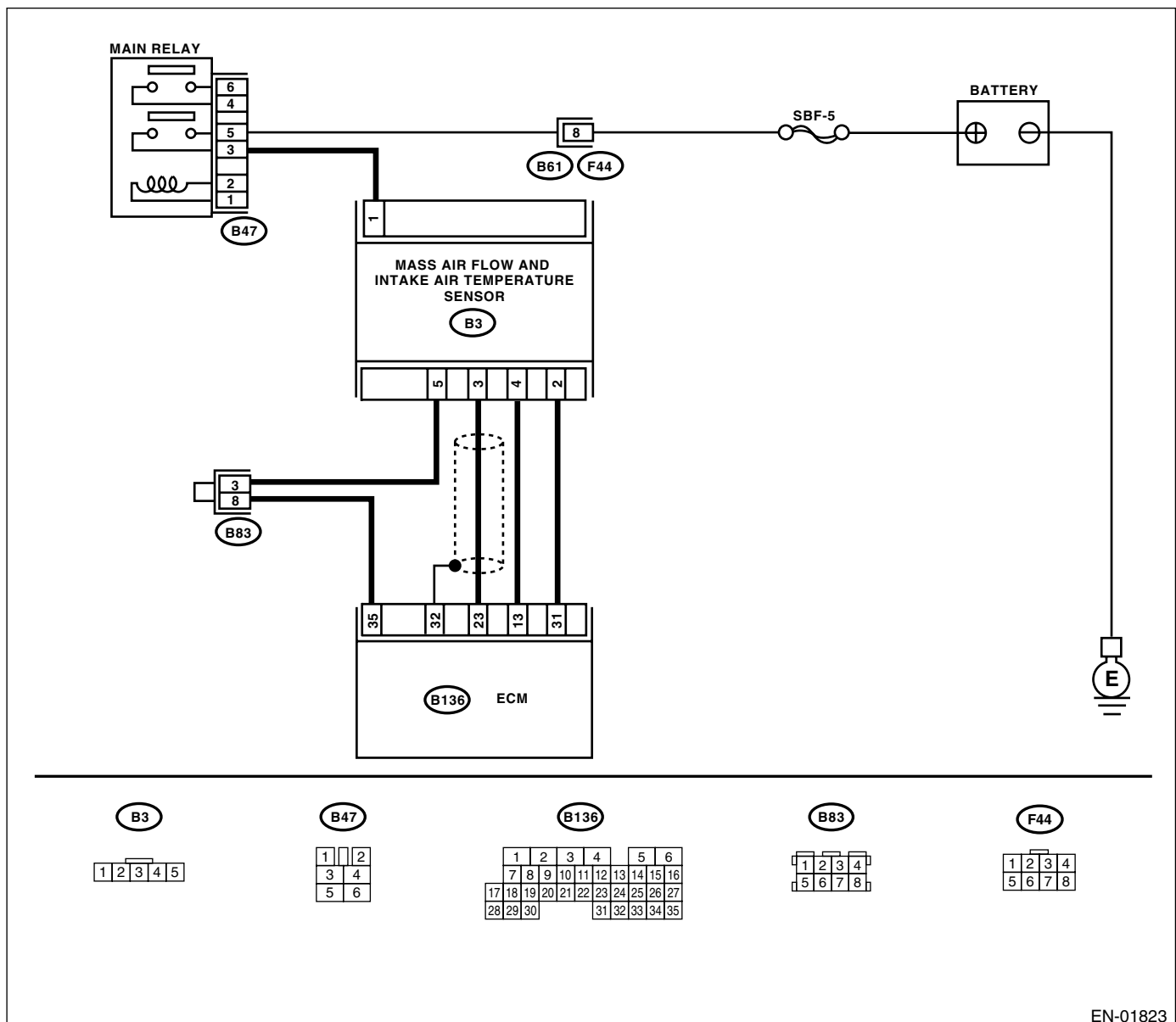

EN-01823

# DIAGNOSTIC PROCEDURE WITH DIAGNOSTIC TROUBLE CODE (DTC)

ENGINE (DIAGNOSTICS)

	Step	Check	Yes	No
1	<b>CHECK ANY OTHER DTC ON DISPLAY.</b>	Is any other DTC displayed?	Inspect the relevant DTC using "List of Diagnostic Trouble Code (DTC)". <Ref. to EN(STi)-66, List of Diagnostic Trouble Code (DTC).>  NOTE: In this case, it is not necessary to inspect DTC P0101.	Replace the mass air flow and intake air temperature sensor. <Ref. to FU(STi)-30, Mass Air Flow and Intake Air Temperature Sensor.>

# DIAGNOSTIC PROCEDURE WITH DIAGNOSTIC TROUBLE CODE (DTC)

ENGINE (DIAGNOSTICS)

## J: DTC P0102 — MASS OR VOLUME AIR FLOW CIRCUIT LOW INPUT —

### • DTC DETECTING CONDITION:

- Immediately at fault recognition
- GENERAL DESCRIPTION <Ref. to GD(STi)-27, DTC P0102 — MASS OR VOLUME AIR FLOW CIRCUIT LOW INPUT —, Diagnostic Trouble Code (DTC) Detecting Criteria.>

### • TROUBLE SYMPTOM:

- Erroneous idling
- Engine stalls.
- Poor driving performance

### CAUTION:

After repair or replacement of faulty parts, conduct Clear Memory Mode <Ref. to EN(STi)-42, OPERATION, Clear Memory Mode.> and Inspection Mode <Ref. to EN(STi)-35, OPERATION, Inspection Mode.>.

### • WIRING DIAGRAM:

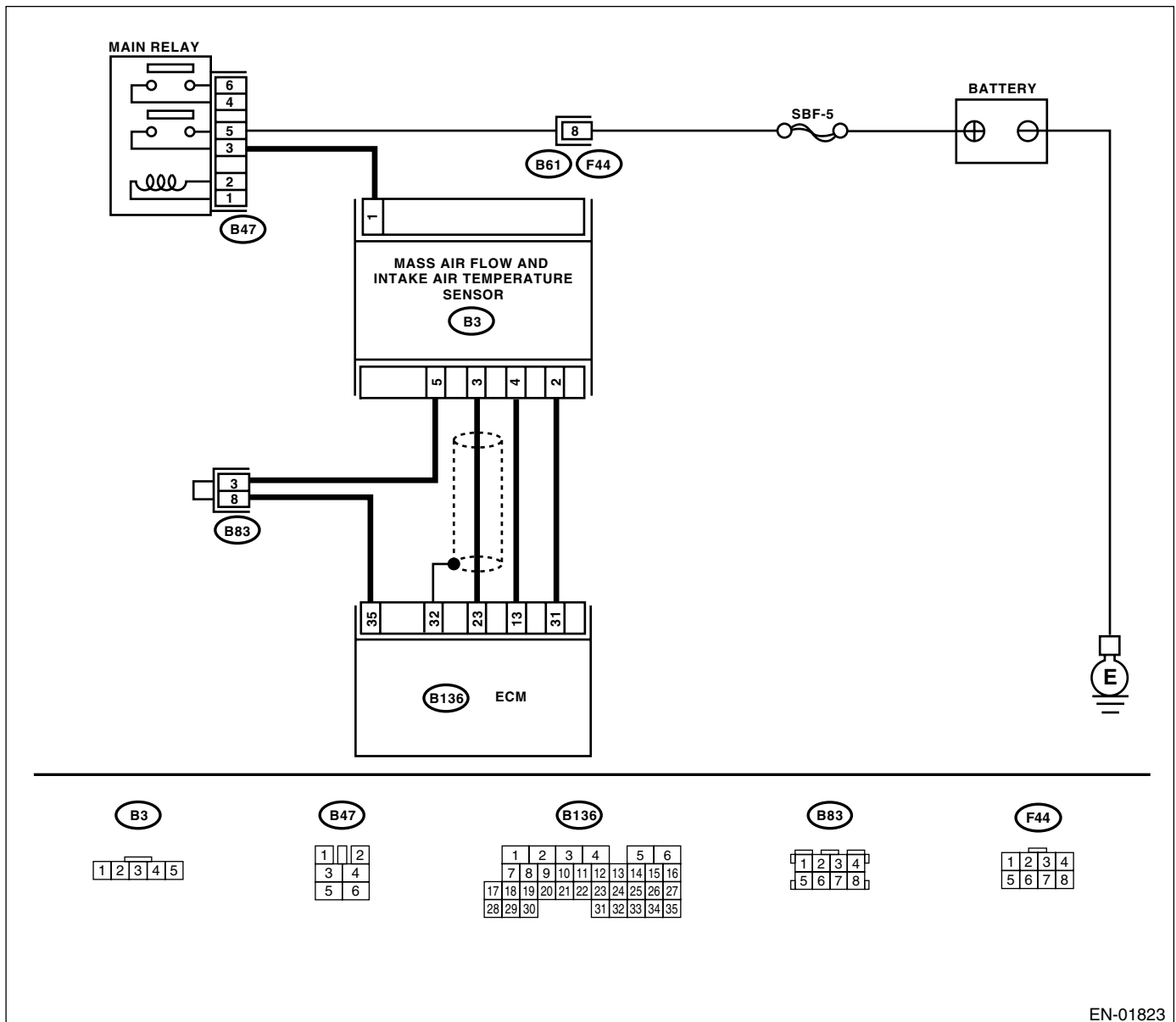

EN-01823

# DIAGNOSTIC PROCEDURE WITH DIAGNOSTIC TROUBLE CODE (DTC)

## ENGINE (DIAGNOSTICS)

Step	Check	Yes	No
<p><b>1 CONNECT SUBARU SELECT MONITOR OR THE OBD-II GENERAL SCAN TOOL, AND READ DATA.</b></p> <p>1) Turn the ignition switch to OFF.                  2) Connect the Subaru Select Monitor or OBD-II general scan tool to data link connector.                  3) Turn the ignition switch to ON and Subaru Select Monitor or the OBD-II general scan tool switch to ON.                  4) Start the engine.                  5) Read the mass air flow sensor voltage using Subaru Select Monitor or OBD-II general scan tool.</p> <p><b>NOTE:</b></p> <ul style="list-style-type: none"> <li>Subaru Select Monitor</li> </ul> <p>For detailed operation procedure, refer to the "READ CURRENT DATA FOR ENGINE".                  &lt;Ref. to EN(STi)-28, Subaru Select Monitor.&gt;</p> <ul style="list-style-type: none"> <li>OBD-II general scan tool</li> </ul> <p>For detailed operation procedures, refer to the OBD-II General Scan Tool Instruction Manual.</p>	<p>Is the voltage 0.2 — 4.7 V?</p>	<p>Even if malfunction indicator light lights up, the circuit has returned to a normal condition at this time. A temporary poor contact of the connector or harness may be the cause. Repair the harness or connector in the mass air flow sensor.</p> <p><b>NOTE:</b></p> <p>In this case, repair the following:</p> <ul style="list-style-type: none"> <li>Open or ground short circuit in harness between mass air flow sensor and ECM connector</li> <li>Poor contact in mass air flow sensor or ECM connector</li> </ul>	<p>Go to step 2.</p>
<p><b>2 CHECK INPUT SIGNAL FOR ECM.</b></p> <p>Measure the voltage between ECM connector and chassis ground while engine is idling.</p> <p><b>Connector &amp; terminal</b>  <b>(B136) No. 23 (+) — Chassis ground (-):</b></p>	<p>Is the voltage less than 0.2 V?</p>	<p>Go to step 4.</p>	<p>Go to step 3.</p>
<p><b>3 CHECK INPUT SIGNAL FOR ECM (USING SUBARU SELECT MONITOR).</b></p> <p>Measure the voltage between ECM connector and chassis ground while engine is idling.</p>	<p>Shake the ECM harness and connector, while monitoring value of Subaru Select Monitor. Does the voltage change?</p>	<p>Repair the poor contact in ECM connector.</p>	<p>Contact your SOA Service Center.</p> <p><b>NOTE:</b></p> <p>Inspection by DTM is required, because probable cause is deterioration of multiple parts.</p>
<p><b>4 CHECK POWER SUPPLY TO MASS AIR FLOW SENSOR.</b></p> <p>1) Turn the ignition switch to OFF.                  2) Disconnect the connector from mass air flow sensor.                  3) Turn the ignition switch to ON.                  4) Measure the voltage between mass air flow sensor connector and chassis ground.</p> <p><b>Connector &amp; terminal</b>  <b>(B3) No. 1 (+) — Chassis ground (-):</b></p>	<p>Is the voltage more than 5 V?</p>	<p>Go to step 5.</p>	<p>Repair the open circuit between mass air flow sensor and main relay.</p>

# DIAGNOSTIC PROCEDURE WITH DIAGNOSTIC TROUBLE CODE (DTC)

ENGINE (DIAGNOSTICS)

Step	Check	Yes	No
<p><b>5</b>      <b>CHECK HARNESS BETWEEN ECM AND MASS AIR FLOW SENSOR CONNECTOR.</b>                      1) Turn the ignition switch to OFF.                      2) Disconnect the connector from ECM.                      3) Measure the resistance of harness between ECM and mass air flow sensor connector.  <i>Connector &amp; terminal</i>  <i>(B136) No. 23 — (B3) No. 3:</i>  <i>(B136) No. 31 — (B3) No. 2:</i>  <i>(B136) No. 35 — (B3) No. 5:</i></p>	<p>Is the resistance less than 1 <math>\Omega</math>?</p>	<p>Go to step 6.</p>	<p>Repair the open circuit between ECM and mass air flow sensor connector.</p>
<p><b>6</b>      <b>CHECK HARNESS BETWEEN ECM AND MASS AIR FLOW SENSOR CONNECTOR</b>                      Measure the resistance of harness between ECM and chassis ground.  <i>Connector &amp; terminal</i>  <i>(B136) No. 23 — Chassis ground:</i>  <i>(B136) No. 31 — Chassis ground:</i>  <i>(B136) No. 35 — Chassis ground:</i></p>	<p>Is the resistance more than 1 M<math>\Omega</math>?</p>	<p>Go to step 7.</p>	<p>Repair the ground short circuit between ECM and mass air flow sensor connector.</p>
<p><b>7</b>      <b>CHECK POOR CONTACT</b>                      Check poor contact in mass air flow sensor connector.</p>	<p>Is there poor contact in mass air flow sensor connector?</p>	<p>Repair the poor contact in mass air flow sensor connector.</p>	<p>Replace the mass air flow and intake air temperature sensor. &lt;Ref. to FU(STi)-30, Mass Air Flow and Intake Air Temperature Sensor.&gt;</p>

# DIAGNOSTIC PROCEDURE WITH DIAGNOSTIC TROUBLE CODE (DTC)

ENGINE (DIAGNOSTICS)

## K: DTC P0103 — MASS OR VOLUME AIR FLOW CIRCUIT HIGH INPUT —

### • DTC DETECTING CONDITION:

- Immediately at fault recognition
- GENERAL DESCRIPTION <Ref. to GD(STi)-29, DTC P0103 — MASS OR VOLUME AIR FLOW CIRCUIT HIGH INPUT —, Diagnostic Trouble Code (DTC) Detecting Criteria.>

### • TROUBLE SYMPTOM:

- Erroneous idling
- Engine stalls.
- Poor driving performance

### CAUTION:

After repair or replacement of faulty parts, conduct Clear Memory Mode <Ref. to EN(STi)-42, OPERATION, Clear Memory Mode.> and Inspection Mode <Ref. to EN(STi)-35, OPERATION, Inspection Mode.>.

### • WIRING DIAGRAM:

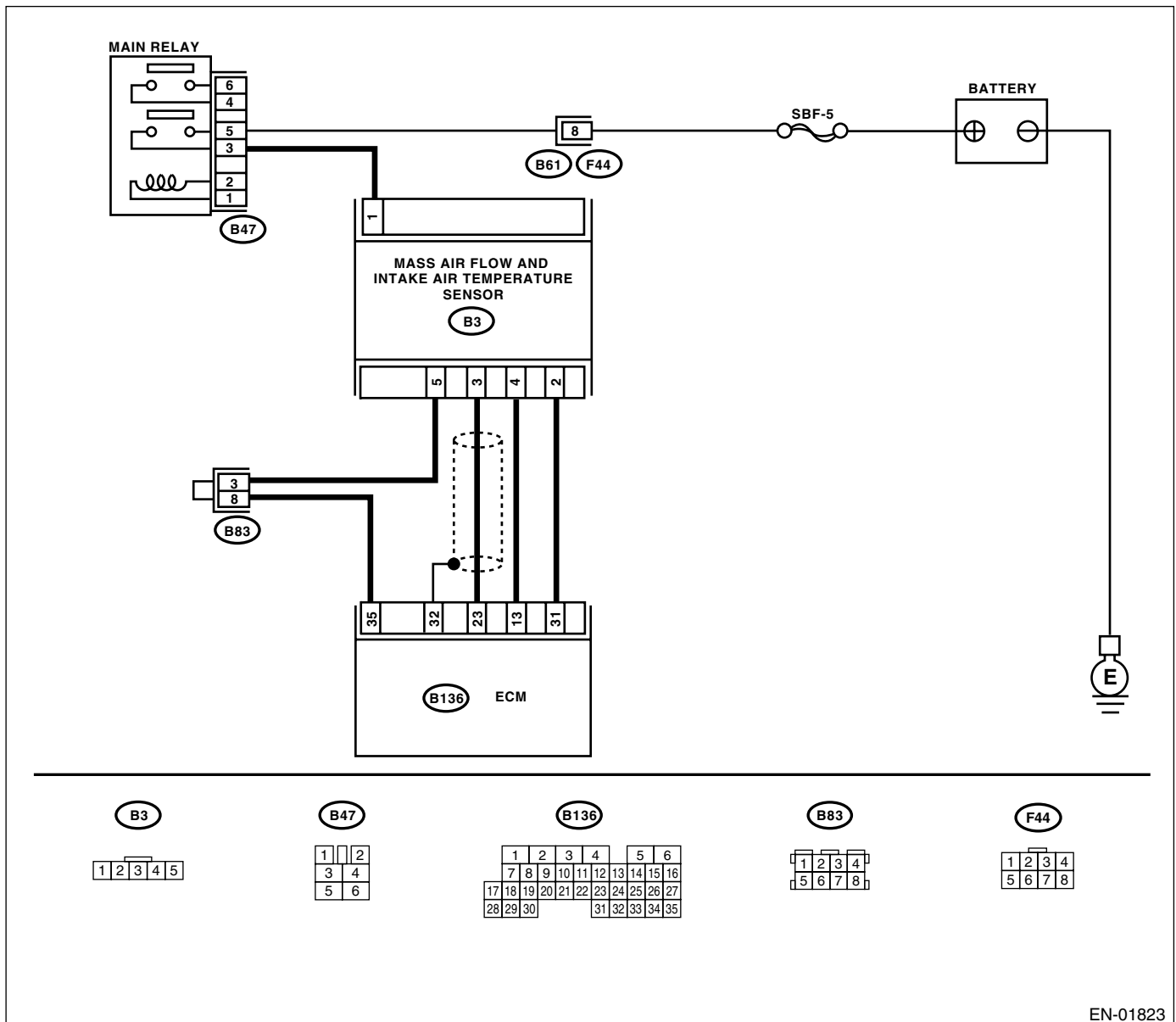

EN-01823

# DIAGNOSTIC PROCEDURE WITH DIAGNOSTIC TROUBLE CODE (DTC)

ENGINE (DIAGNOSTICS)

Step	Check	Yes	No
<p><b>1 CONNECT SUBARU SELECT MONITOR OR THE OBD-II GENERAL SCAN TOOL, AND READ DATA.</b></p> <p>1) Turn the ignition switch to OFF.                      2) Connect the Subaru Select Monitor or OBD-II general scan tool to data link connector.                      3) Turn the ignition switch to ON and Subaru Select Monitor or OBD-II general scan tool switch to ON.                      4) Start the engine.                      5) Read the mass air flow sensor voltage using Subaru Select Monitor or OBD-II general scan tool.</p> <p><b>NOTE:</b></p> <ul style="list-style-type: none"> <li>• Subaru Select Monitor                              For detailed operation procedure, refer to the "READ CURRENT DATA FOR ENGINE".                              &lt;Ref. to EN(STi)-28, Subaru Select Monitor.&gt;</li> <li>• OBD-II general scan tool                              For detailed operation procedures, refer to the OBD-II General Scan Tool Instruction Manual.</li> </ul>	<p>Is the voltage 0.2 — 4.7 V?</p>	<p>Even if malfunction indicator light lights up, the circuit has returned to a normal condition at this time.</p>	<p>Go to step 2.</p>
<p><b>2 CHECK HARNESS BETWEEN ECM AND MASS AIR FLOW SENSOR CONNECTOR.</b></p> <p>1) Turn the ignition switch to OFF.                      2) Disconnect the connector from mass air flow sensor.                      3) Turn the ignition switch to ON.                      4) Measure the voltage between mass air flow sensor connector and chassis ground.</p> <p><b>Connector &amp; terminal</b>  <b>(B3) No. 3 (+) — Chassis ground (-):</b></p>	<p>Is the voltage more than 5 V?</p>	<p>Repair the battery short of harness between mass air flow sensor connector and ECM connector.</p>	<p>Go to step 3.</p>
<p><b>3 CHECK HARNESS BETWEEN ECM AND MASS AIR FLOW SENSOR CONNECTOR.</b></p> <p>1) Turn the ignition switch to OFF.                      2) Disconnect the connector from ECM.                      3) Measure the resistance between ECM connector and mass air flow sensor connector.</p> <p><b>Connector &amp; terminal</b>  <b>(B3) No. 2 — (B136) No. 31:</b></p>	<p>Is the resistance less than 1 <math>\Omega</math>?</p>	<p>Replace the mass air flow sensor.                      &lt;Ref. to FU(STi)-30, Mass Air Flow and Intake Air Temperature Sensor.&gt;</p>	<p>Repair the open harness between mass air flow sensor connector and ECM connector.</p>

# DIAGNOSTIC PROCEDURE WITH DIAGNOSTIC TROUBLE CODE (DTC)

ENGINE (DIAGNOSTICS)

## L: DTC P0107 — MANIFOLD ABSOLUTE PRESSURE/BAROMETRIC PRESSURE CIRCUIT LOW INPUT —

### • DTC DETECTING CONDITION:

- Immediately at fault recognition
- GENERAL DESCRIPTION <Ref. to GD(STi)-31, DTC P0107 — MANIFOLD ABSOLUTE PRESSURE/BAROMETRIC PRESSURE CIRCUIT LOW INPUT —, Diagnostic Trouble Code (DTC) Detecting Criteria.>

### CAUTION:

After repair or replacement of faulty parts, conduct Clear Memory Mode <Ref. to EN(STi)-42, OPERATION, Clear Memory Mode.> and Inspection Mode <Ref. to EN(STi)-35, OPERATION, Inspection Mode.>.

### • WIRING DIAGRAM:

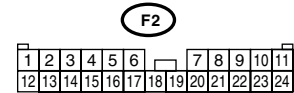
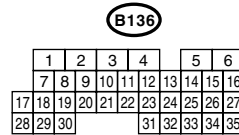
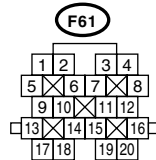
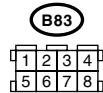
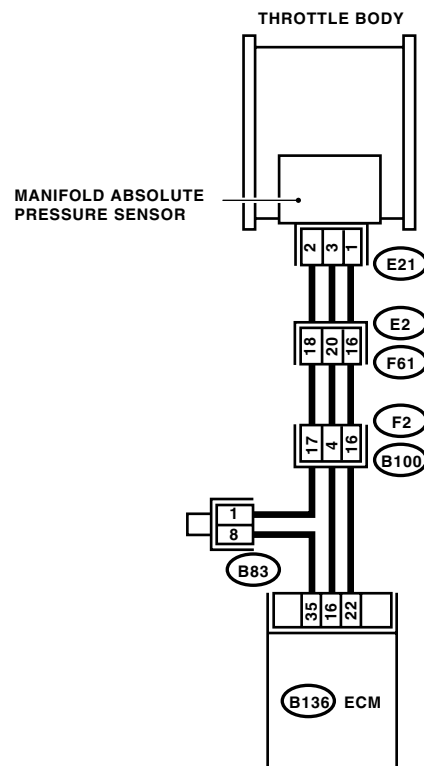

EN-01822



# DIAGNOSTIC PROCEDURE WITH DIAGNOSTIC TROUBLE CODE (DTC)

ENGINE (DIAGNOSTICS)

Step	Check	Yes	No
<b>1 CHECK INPUT SIGNAL FOR ECM.</b> Measure the voltage between ECM connector and chassis ground. <i>Connector &amp; terminal</i> <i>(B136) No. 16 (+) — Chassis ground (-):</i>	Is the voltage more than 4.5 V?	Go to step 3.	Go to step 2.
<b>2 CHECK INPUT SIGNAL FOR ECM.</b> Measure the voltage between ECM connector and chassis ground. <i>Connector &amp; terminal</i> <i>(B136) No. 16 (+) — Chassis ground (-):</i>	Shake the ECM harness and connector, while monitoring value of voltage meter. Does the voltage change?	Repair the poor contact in ECM connector.	Contact your SOA Service Center.  NOTE: Inspection by DTM is required, because probable cause is deterioration of multiple parts.
<b>3 CHECK INPUT SIGNAL FOR ECM.</b> Measure the voltage between ECM and chassis ground. <i>Connector &amp; terminal</i> <i>(B136) No. 22 (+) — Chassis ground (-):</i>	Is the voltage less than 0.7 V?	Go to step 4.	Contact your SOA Service Center.  NOTE: Inspection by DTM is required, because probable cause is deterioration of multiple parts.
<b>4 CHECK HARNESS BETWEEN ECM AND MANIFOLD ABSOLUTE PRESSURE SENSOR CONNECTOR.</b> 1)Turn the ignition switch to OFF. 2)Disconnect the connector from manifold absolute pressure sensor. 3)Turn the ignition switch to ON. 4)Measure the voltage between manifold absolute pressure sensor connector and engine ground. <i>Connector &amp; terminal</i> <i>(E21) No. 3 (+) — Engine ground (-):</i>	Is the voltage more than 4.5 V?	Go to step 5.	Repair the open circuit in harness between ECM and manifold absolute pressure sensor connector.
<b>5 CHECK HARNESS BETWEEN ECM AND MANIFOLD ABSOLUTE PRESSURE SENSOR CONNECTOR.</b> 1)Turn the ignition switch to OFF. 2)Disconnect the connector from ECM. 3)Measure the resistance of harness between ECM and manifold absolute pressure sensor connector. <i>Connector &amp; terminal</i> <i>(B136) No. 35 — (E21) No. 2:</i>	Is the resistance less than 1 $\Omega$ ?	Go to step 6.	Repair the open circuit in harness between ECM and manifold absolute pressure sensor connector.
<b>6 CHECK HARNESS BETWEEN ECM AND MANIFOLD ABSOLUTE PRESSURE SENSOR CONNECTOR.</b> Measure the resistance of harness between manifold absolute pressure sensor connector and engine ground. <i>Connector &amp; terminal</i> <i>(E21) No. 1 — Engine ground:</i>	Is the resistance more than 1 M $\Omega$ ?	Go to step 7.	Repair the ground short circuit in harness between ECM and manifold absolute pressure sensor connector.
<b>7 CHECK POOR CONTACT.</b> Check poor contact in manifold absolute pressure sensor connector.	Is there poor contact in manifold absolute pressure sensor connector?	Repair the poor contact in manifold absolute pressure sensor connector.	Replace the manifold absolute pressure sensor. <Ref. to FU(STi)-31, Manifold Absolute Pressure Sensor.>

# DIAGNOSTIC PROCEDURE WITH DIAGNOSTIC TROUBLE CODE (DTC)

ENGINE (DIAGNOSTICS)

## M: DTC P0108 — MANIFOLD ABSOLUTE PRESSURE/BAROMETRIC PRESSURE CIRCUIT HIGH INPUT —

### • DTC DETECTING CONDITION:

- Immediately at fault recognition
- GENERAL DESCRIPTION <Ref. to GD(STi)-33, DTC P0108 — MANIFOLD ABSOLUTE PRESSURE/BAROMETRIC PRESSURE CIRCUIT HIGH INPUT —, Diagnostic Trouble Code (DTC) Detecting Criteria.>

### CAUTION:

After repair or replacement of faulty parts, conduct Clear Memory Mode <Ref. to EN(STi)-42, OPERATION, Clear Memory Mode.> and Inspection Mode <Ref. to EN(STi)-35, OPERATION, Inspection Mode.>.

### • WIRING DIAGRAM:

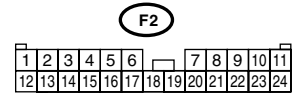
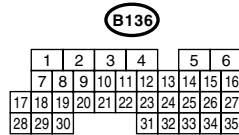
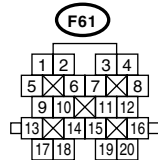
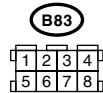
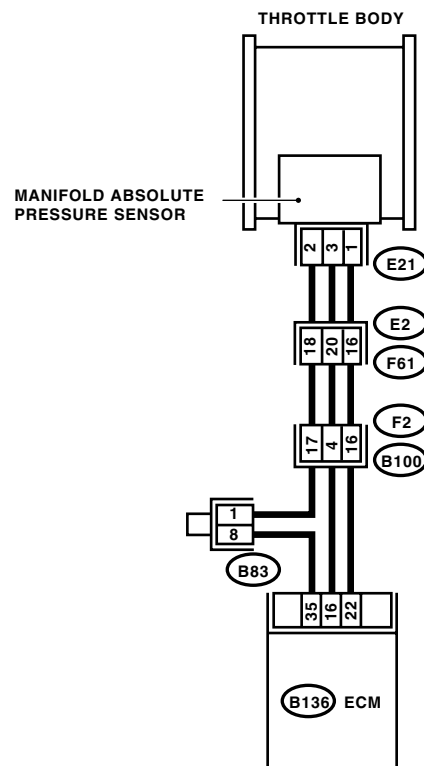

EN-01822

# DIAGNOSTIC PROCEDURE WITH DIAGNOSTIC TROUBLE CODE (DTC)

ENGINE (DIAGNOSTICS)

Step	Check	Yes	No
<b>1 CHECK INPUT SIGNAL FOR ECM.</b> Measure the voltage between ECM connector and chassis ground. <i>Connector &amp; terminal</i> <i>(B136) No. 16 (+) — Chassis ground (-):</i>	Is the voltage more than 4.5 V?	Go to step 3.	Go to step 2.
<b>2 CHECK INPUT SIGNAL FOR ECM.</b> Measure the voltage between ECM connector and chassis ground. <i>Connector &amp; terminal</i> <i>(B136) No. 16 (+) — Chassis ground (-):</i>	Shake the ECM harness and connector, while monitoring value of voltage meter. Does the voltage change?	Repair the poor contact in ECM connector.	Contact your SOA Service Center.  NOTE: Inspection by DTM is required, because probable cause is deterioration of multiple parts.
<b>3 CHECK INPUT SIGNAL FOR ECM.</b> Measure the voltage between ECM connector and chassis ground. <i>Connector &amp; terminal</i> <i>(B136) No. 22 (+) — Chassis ground (-):</i>	Is the voltage more than 4.5 V?	Go to step 4.	Contact your SOA Service Center.  NOTE: Inspection by DTM is required, because probable cause is deterioration of multiple parts.
<b>4 CHECK HARNESS BETWEEN ECM AND MANIFOLD ABSOLUTE PRESSURE SENSOR CONNECTOR.</b> 1) Turn the ignition switch to OFF. 2) Disconnect the connector from manifold absolute pressure sensor. 3) Turn the ignition switch to ON. 4) Measure the voltage between manifold absolute pressure sensor connector and engine ground. <i>Connector &amp; terminal</i> <i>(E21) No. 3 (+) — Engine ground (-):</i>	Is the voltage more than 4.5 V?	Go to step 5.	Repair the open circuit in harness between ECM and manifold absolute pressure sensor connector.
<b>5 CHECK HARNESS BETWEEN ECM AND MANIFOLD ABSOLUTE PRESSURE SENSOR CONNECTOR.</b> 1) Turn the ignition switch to OFF. 2) Disconnect the connector from ECM. 3) Measure the resistance of harness between ECM and manifold absolute pressure sensor connector. <i>Connector &amp; terminal</i> <i>(B136) No. 22 — (E21) No. 1:</i>	Is the resistance less than 1 $\Omega$ ?	Go to step 6.	Repair the open circuit in harness between ECM and manifold absolute pressure sensor connector.
<b>6 CHECK HARNESS BETWEEN ECM AND MANIFOLD ABSOLUTE PRESSURE SENSOR CONNECTOR.</b> Measure the resistance of harness between ECM and manifold absolute pressure sensor connector. <i>Connector &amp; terminal</i> <i>(B136) No. 35 — (E21) No. 2:</i>	Is the resistance less than 1 $\Omega$ ?	Go to step 7.	Repair the open circuit in harness between ECM and manifold absolute pressure sensor connector.
<b>7 CHECK POOR CONTACT.</b> Check poor contact in manifold absolute pressure sensor connector.	Is there poor contact in manifold absolute pressure sensor connector?	Repair the poor contact in manifold absolute pressure sensor connector.	Replace the manifold absolute pressure sensor. <Ref. to FU(STi)-31, Manifold Absolute Pressure Sensor.>

# DIAGNOSTIC PROCEDURE WITH DIAGNOSTIC TROUBLE CODE (DTC)

ENGINE (DIAGNOSTICS)

## N: DTC P0111 — INTAKE AIR TEMPERATURE CIRCUIT RANGE/PERFORMANCE —

### • DTC DETECTING CONDITION:

- Two consecutive driving cycles with fault
- GENERAL DESCRIPTION <Ref. to GD(STi)-35, DTC P0111 — INTAKE AIR TEMPERATURE CIRCUIT RANGE/PERFORMANCE —, Diagnostic Trouble Code (DTC) Detecting Criteria.>

### • TROUBLE SYMPTOM:

- Erroneous idling
- Poor driving performance

### CAUTION:

After repair or replacement of faulty parts, conduct Clear Memory Mode <Ref. to EN(STi)-42, OPERATION, Clear Memory Mode.> and Inspection Mode <Ref. to EN(STi)-35, OPERATION, Inspection Mode.>.

### • WIRING DIAGRAM:

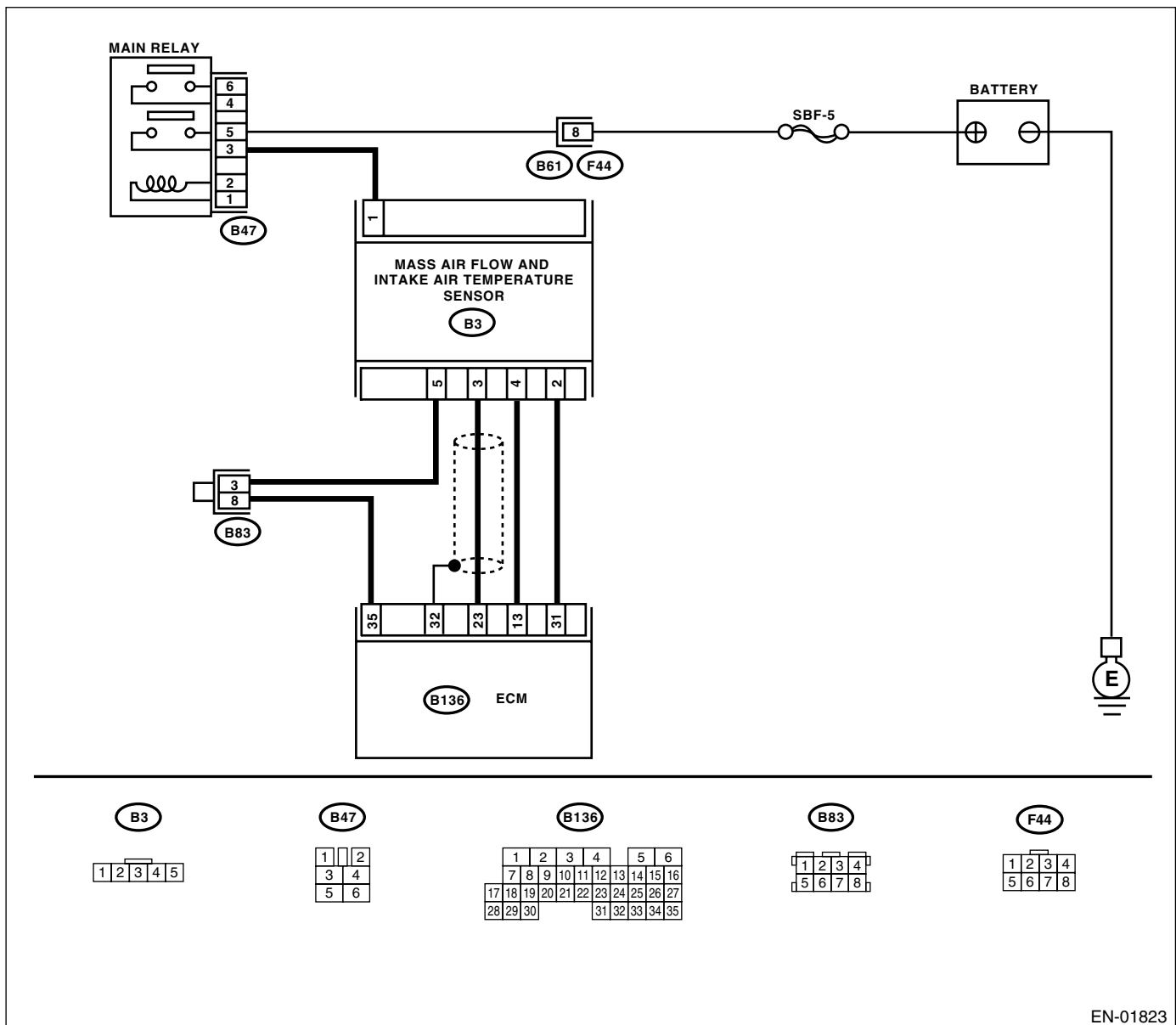

EN-01823

# DIAGNOSTIC PROCEDURE WITH DIAGNOSTIC TROUBLE CODE (DTC)

## ENGINE (DIAGNOSTICS)

Step	Check	Yes	No
<b>1</b> <b>CHECK ANY OTHER DTC ON DISPLAY.</b>	Is any other DTC displayed?	Inspect the relevant DTC using "List of Diagnostic Trouble Code (DTC)". <Ref. to EN(STi)-66, List of Diagnostic Trouble Code (DTC).>  NOTE: In this case, it is not necessary to inspect DTC P0111.	Go to step 2.
<b>2</b> <b>CHECK ENGINE COOLANT TEMPERATURE.</b> 1) Start the engine and warm it up completely. 2) Measure the engine coolant temperature using Subaru Select Monitor or OBD-II general scan tool.  NOTE: •Subaru Select Monitor For detailed operation procedure, refer to the "READ CURRENT DATA FOR ENGINE". <Ref. to EN(STi)-28, Subaru Select Monitor.> •OBD-II general scan tool For detailed operation procedures, refer to the OBD-II General Scan Tool Instruction Manual.	Is the engine coolant temperature 75°C (167°F) — 95°C (203°F)?	Replace the mass air flow and intake air temperature sensor. <Ref. to FU(STi)-30, Mass Air Flow and Intake Air Temperature Sensor.>	Inspect the DTC P0125 using "List of Diagnostic Trouble Code (DTC)". <Ref. to EN(STi)-66, List of Diagnostic Trouble Code (DTC).>

# DIAGNOSTIC PROCEDURE WITH DIAGNOSTIC TROUBLE CODE (DTC)

ENGINE (DIAGNOSTICS)

## O: DTC P0112 — INTAKE AIR TEMPERATURE CIRCUIT LOW INPUT

### • DTC DETECTING CONDITION:

- Immediately at fault recognition
- GENERAL DESCRIPTION <Ref. to GD(STi)-37, DTC P0112 — INTAKE AIR TEMPERATURE CIRCUIT LOW INPUT —, Diagnostic Trouble Code (DTC) Detecting Criteria.>

### • TROUBLE SYMPTOM:

- Erroneous idling
- Poor driving performance

### CAUTION:

After repair or replacement of faulty parts, conduct Clear Memory Mode <Ref. to EN(STi)-42, OPERATION, Clear Memory Mode.> and Inspection Mode <Ref. to EN(STi)-35, OPERATION, Inspection Mode.>.

### • WIRING DIAGRAM:

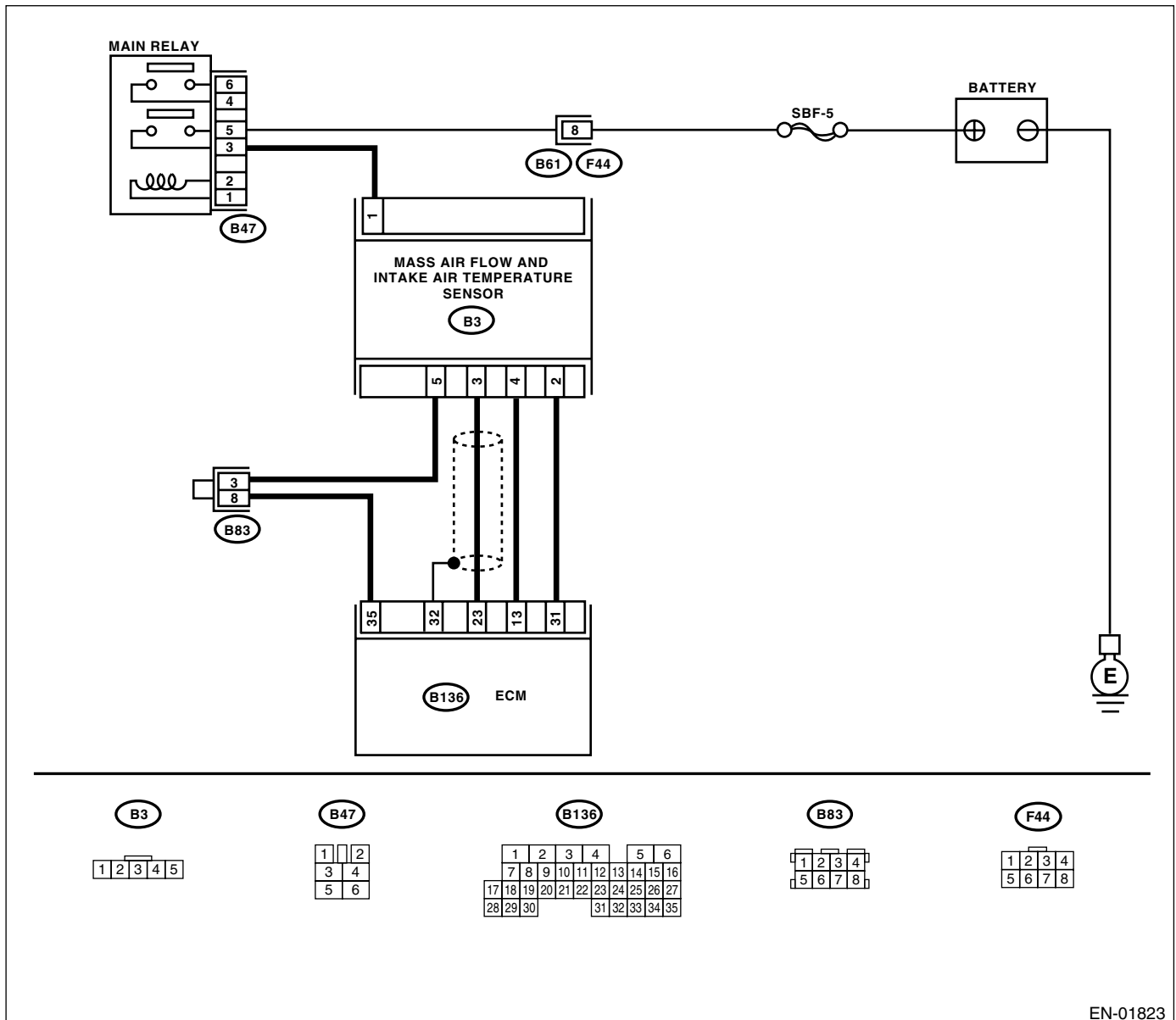

EN-01823

# DIAGNOSTIC PROCEDURE WITH DIAGNOSTIC TROUBLE CODE (DTC)

## ENGINE (DIAGNOSTICS)

Step	Check	Yes	No
<p><b>1</b></p> <p><b>CHECK CURRENT DATA.</b></p> <p>1)Start the engine.</p> <p>2)Read the data of intake air temperature sensor signal using Subaru Select Monitor or the OBD-II general scan tool.</p> <p>NOTE:</p> <ul style="list-style-type: none"> <li>•Subaru Select Monitor</li> </ul> <p>For detailed operation procedure, refer to the "READ CURRENT DATA FOR ENGINE".</p> <p>&lt;Ref. to EN(STi)-28, Subaru Select Monitor.&gt;</p> <ul style="list-style-type: none"> <li>•OBD-II general scan tool</li> </ul> <p>For detailed operation procedure, refer to the OBD-II General Scan Tool Instruction Manual.</p>	<p>Is the temperature more than 55°C (131°F)?</p>	<p>Go to step 2.</p>	<p>Repair the poor contact.</p> <p>NOTE:</p> <p>In this case, repair the following:</p> <ul style="list-style-type: none"> <li>• Poor contact mass air flow and intake air temperature sensor</li> <li>• Poor contact in ECM</li> <li>• Poor contact in joint connector</li> </ul>
<p><b>2</b></p> <p><b>CHECK HARNESS BETWEEN MASS AIR FLOW AND INTAKE AIR TEMPERATURE SENSOR AND ECM CONNECTOR.</b></p> <p>1)Turn the ignition switch to OFF.</p> <p>2)Disconnect the connector from mass air flow and intake air temperature sensor.</p> <p>3)Turn the ignition switch to ON.</p> <p>4)Read the data of intake air temperature sensor signal using Subaru Select Monitor or the OBD-II general scan tool.</p> <p>NOTE:</p> <ul style="list-style-type: none"> <li>•Subaru Select Monitor</li> </ul> <p>For detailed operation procedure, refer to the "READ CURRENT DATA FOR ENGINE".</p> <p>&lt;Ref. to EN(STi)-28, Subaru Select Monitor.&gt;</p> <ul style="list-style-type: none"> <li>•OBD-II general scan tool</li> </ul> <p>For detailed operation procedure, refer to the OBD-II General Scan Tool Instruction Manual.</p>	<p>Is the temperature less than -36°C (-33°F)?</p>	<p>Replace the mass air flow and intake air temperature sensor. &lt;Ref. to FU(STi)-30, Mass Air Flow and Intake Air Temperature Sensor.&gt;</p>	<p>Repair the ground short circuit in harness between mass air flow and intake air temperature sensor and ECM connector.</p>

# DIAGNOSTIC PROCEDURE WITH DIAGNOSTIC TROUBLE CODE (DTC)

ENGINE (DIAGNOSTICS)

## P: DTC P0113 — INTAKE AIR TEMPERATURE CIRCUIT HIGH INPUT —

### • DTC DETECTING CONDITION:

- Immediately at fault recognition
- GENERAL DESCRIPTION <Ref. to GD(STi)-39, DTC P0113 — INTAKE AIR TEMPERATURE CIRCUIT HIGH INPUT —, Diagnostic Trouble Code (DTC) Detecting Criteria.>

### • TROUBLE SYMPTOM:

- Erroneous idling
- Poor driving performance

### CAUTION:

After repair or replacement of faulty parts, conduct Clear Memory Mode <Ref. to EN(STi)-42, OPERATION, Clear Memory Mode.> and Inspection Mode <Ref. to EN(STi)-35, OPERATION, Inspection Mode.>.

### • WIRING DIAGRAM:

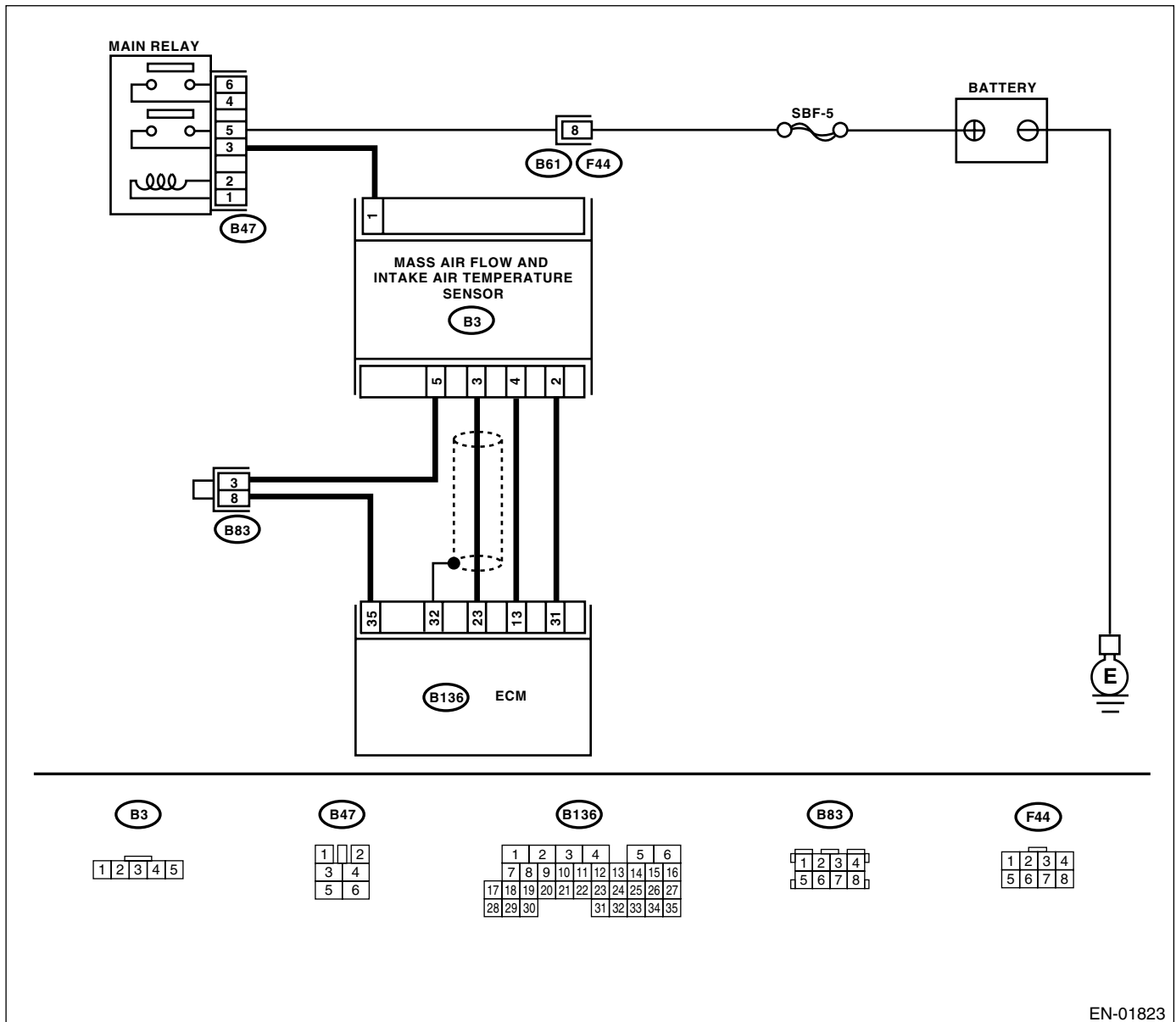

EN-01823



# DIAGNOSTIC PROCEDURE WITH DIAGNOSTIC TROUBLE CODE (DTC)

## ENGINE (DIAGNOSTICS)

Step	Check	Yes	No
<p><b>1</b></p> <p><b>CHECK CURRENT DATA.</b></p> <p>1) Start the engine.</p> <p>2) Read the data of intake air temperature sensor signal using Subaru Select Monitor or the OBD-II general scan tool.</p> <p>NOTE:</p> <ul style="list-style-type: none"> <li>• Subaru Select Monitor</li> </ul> <p>For detailed operation procedure, refer to the "READ CURRENT DATA FOR ENGINE".</p> <p>&lt;Ref. to EN(STi)-28, Subaru Select Monitor.&gt;</p> <ul style="list-style-type: none"> <li>• OBD-II general scan tool</li> </ul> <p>For detailed operation procedure, refer to the OBD-II General Scan Tool Instruction Manual.</p>	<p>Is the temperature less than <math>-36^{\circ}\text{C}</math> (<math>-33^{\circ}\text{F}</math>)?</p>	<p>Go to step 2.</p>	<p>Repair the poor contact.</p> <p>NOTE:</p> <p>In this case, repair the following:</p> <ul style="list-style-type: none"> <li>• Poor contact in mass air flow and intake air temperature sensor</li> <li>• Poor contact in ECM</li> <li>• Poor contact in joint connector</li> </ul>
<p><b>2</b></p> <p><b>CHECK HARNESS BETWEEN MASS AIR FLOW AND INTAKE AIR TEMPERATURE SENSOR AND ECM CONNECTOR.</b></p> <p>1) Turn the ignition switch to OFF.</p> <p>2) Disconnect the connector from mass air flow and intake air temperature sensor.</p> <p>3) Measure the voltage between mass air flow and intake air temperature sensor connector and engine ground.</p> <p><b>Connector &amp; terminal</b></p> <p><b>(B3) No. 4 (+) — Engine ground (-):</b></p>	<p>Is the voltage more than 10 V?</p>	<p>Repair the battery short circuit in harness between mass air flow and intake air temperature sensor and ECM connector.</p>	<p>Go to step 3.</p>
<p><b>3</b></p> <p><b>CHECK HARNESS BETWEEN MASS AIR FLOW AND INTAKE AIR TEMPERATURE SENSOR AND ECM CONNECTOR.</b></p> <p>1) Turn the ignition switch to ON.</p> <p>2) Measure the voltage between mass air flow and intake air temperature sensor connector and engine ground.</p> <p><b>Connector &amp; terminal</b></p> <p><b>(B3) No. 4 (+) — Engine ground (-):</b></p>	<p>Is the voltage more than 10 V?</p>	<p>Repair the battery short circuit in harness between mass air flow and intake air temperature sensor and ECM connector.</p>	<p>Go to step 4.</p>
<p><b>4</b></p> <p><b>CHECK HARNESS BETWEEN MASS AIR FLOW AND INTAKE AIR TEMPERATURE SENSOR AND ECM CONNECTOR.</b></p> <p>Measure the voltage between mass air flow and intake air temperature sensor and manifold absolute pressure sensor connector and engine ground.</p> <p><b>Connector &amp; terminal</b></p> <p><b>(B3) No. 4 (+) — Engine ground (-):</b></p>	<p>Is the voltage more than 4 V?</p>	<p>Go to step 5.</p>	<p>Repair the harness and connector.</p> <p>NOTE:</p> <p>In this case, repair the following:</p> <ul style="list-style-type: none"> <li>• Open circuit in harness between mass air flow and intake air temperature sensor and ECM connector</li> <li>• Poor contact in mass air flow and intake air temperature sensor</li> <li>• Poor contact in ECM</li> <li>• Poor contact in joint connector</li> </ul>

# DIAGNOSTIC PROCEDURE WITH DIAGNOSTIC TROUBLE CODE (DTC)

ENGINE (DIAGNOSTICS)

Step	Check	Yes	No
<p>5</p> <p><b>CHECK HARNESS BETWEEN MASS AIR FLOW AND INTAKE AIR TEMPERATURE SENSOR AND ECM CONNECTOR.</b></p> <p>1) Turn the ignition switch to OFF.</p> <p>2) Measure the resistance of harness between mass air flow and intake air temperature sensor and engine ground.</p> <p><b>Connector &amp; terminal</b> <b>(B3) No. 5 — Engine ground:</b></p>	<p>Is the resistance less than 5 <math>\Omega</math>?</p>	<p>Replace the mass air flow and intake air temperature sensor. &lt;Ref. to FU(STi)-30, Mass Air Flow and Intake Air Temperature Sensor.&gt;</p>	<p>Repair the harness and connector.</p> <p><b>NOTE:</b> In this case, repair the following:</p> <ul style="list-style-type: none"><li>• Open circuit in harness between mass air flow and intake air temperature sensor and ECM connector</li><li>• Poor contact in mass air flow and intake air temperature sensor</li><li>• Poor contact in ECM</li><li>• Poor contact in joint connector</li></ul>

# DIAGNOSTIC PROCEDURE WITH DIAGNOSTIC TROUBLE CODE (DTC)

ENGINE (DIAGNOSTICS)

## Q: DTC P0117 — ENGINE COOLANT TEMPERATURE CIRCUIT LOW INPUT —

### • DTC DETECTING CONDITION:

- Immediately at fault recognition
- GENERAL DESCRIPTION <Ref. to GD(STi)-41, DTC P0117 — ENGINE COOLANT TEMPERATURE CIRCUIT LOW INPUT —, Diagnostic Trouble Code (DTC) Detecting Criteria.>

### • TROUBLE SYMPTOM:

- Hard to start
- Erroneous idling
- Poor driving performance

### CAUTION:

After repair or replacement of faulty parts, conduct Clear Memory Mode <Ref. to EN(STi)-42, OPERATION, Clear Memory Mode.> and Inspection Mode <Ref. to EN(STi)-35, OPERATION, Inspection Mode.>.

### • WIRING DIAGRAM:

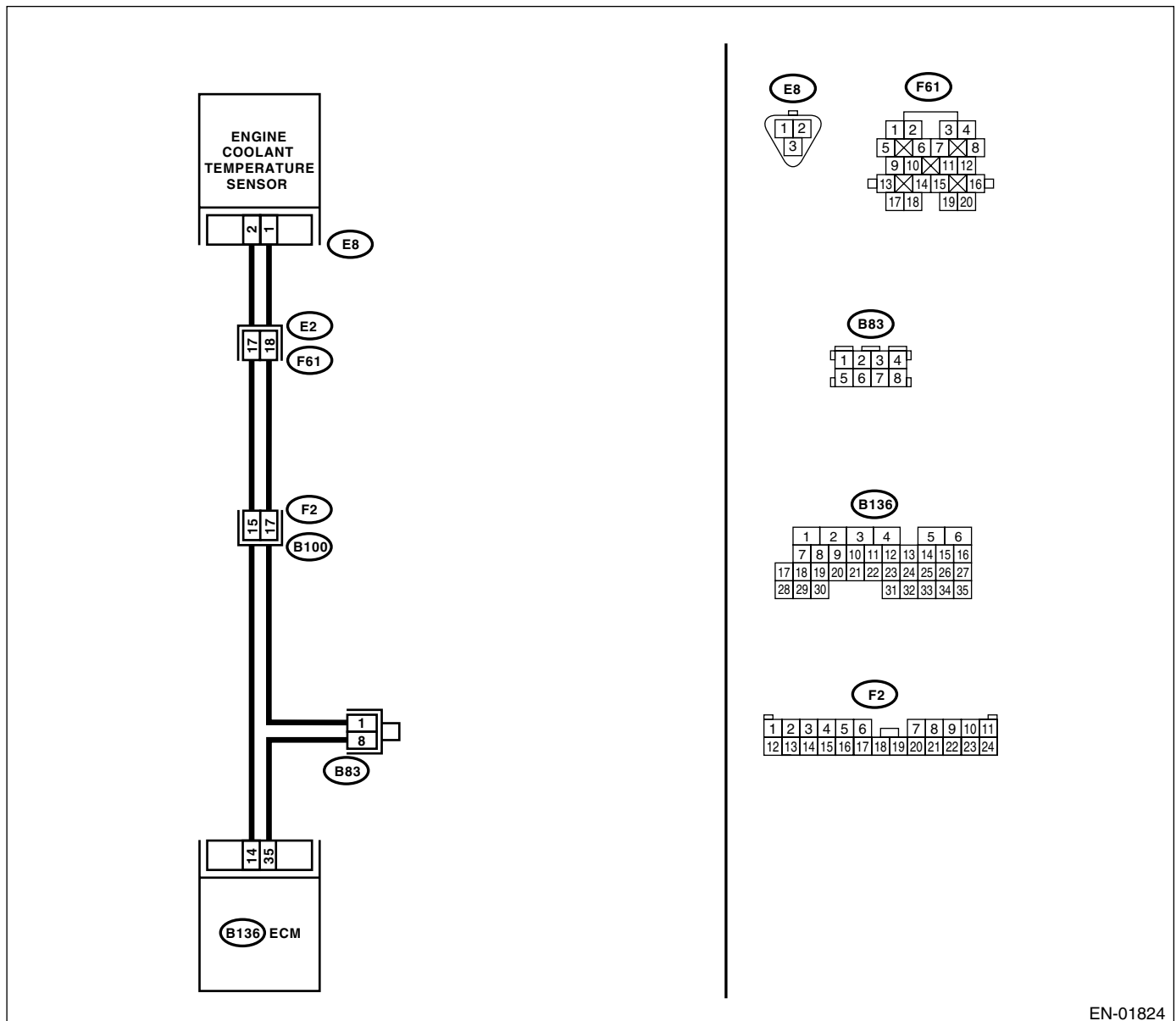

EN-01824

# DIAGNOSTIC PROCEDURE WITH DIAGNOSTIC TROUBLE CODE (DTC)

## ENGINE (DIAGNOSTICS)

Step	Check	Yes	No
<p><b>1</b></p> <p><b>CHECK CURRENT DATA.</b></p> <p>1)Start the engine.</p> <p>2)Read the data of engine coolant temperature sensor signal using Subaru Select Monitor or OBD-II general scan tool.</p> <p>NOTE:</p> <ul style="list-style-type: none"> <li>•Subaru Select Monitor</li> </ul> <p>For detailed operation procedure, refer to the "READ CURRENT DATA FOR ENGINE".</p> <p>&lt;Ref. to EN(STi)-28, Subaru Select Monitor.&gt;</p> <ul style="list-style-type: none"> <li>•OBD-II general scan tool</li> </ul> <p>For detailed operation procedures, refer to the OBD-II General Scan Tool Instruction Manual.</p>	<p>Is the temperature more than 120°C (248°F)?</p>	<p>Go to step 2.</p>	<p>Repair the poor contact.</p> <p>NOTE:</p> <p>In this case, repair the following:</p> <ul style="list-style-type: none"> <li>• Poor contact in engine coolant temperature sensor</li> <li>• Poor contact in ECM</li> <li>• Poor contact in coupling connector</li> <li>• Poor contact in joint connector</li> </ul>
<p><b>2</b></p> <p><b>CHECK HARNESS BETWEEN ENGINE COOLANT TEMPERATURE SENSOR AND ECM CONNECTOR.</b></p> <p>1)Turn the ignition switch to OFF.</p> <p>2)Disconnect the connector from engine coolant temperature sensor.</p> <p>3)Turn the ignition switch to ON.</p> <p>4)Read the data of engine coolant temperature sensor signal using Subaru Select Monitor or OBD-II general scan tool.</p> <p>NOTE:</p> <ul style="list-style-type: none"> <li>•Subaru Select Monitor</li> </ul> <p>For detailed operation procedure, refer to the "READ CURRENT DATA FOR ENGINE".</p> <p>&lt;Ref. to EN(STi)-28, Subaru Select Monitor.&gt;</p> <ul style="list-style-type: none"> <li>•OBD-II general scan tool</li> </ul> <p>For detailed operation procedures, refer to the OBD-II General Scan Tool Instruction Manual.</p>	<p>Is the temperature less than -40°C (-40°F)?</p>	<p>Replace the engine coolant temperature sensor. &lt;Ref. to FU(STi)-26, Engine Coolant Temperature Sensor.&gt;</p>	<p>Repair the ground short circuit in harness between engine coolant temperature sensor and ECM connector.</p>

# DIAGNOSTIC PROCEDURE WITH DIAGNOSTIC TROUBLE CODE (DTC)

ENGINE (DIAGNOSTICS)

## R: DTC P0118 — ENGINE COOLANT TEMPERATURE CIRCUIT HIGH INPUT —

### • DTC DETECTING CONDITION:

- Immediately at fault recognition
- GENERAL DESCRIPTION <Ref. to GD(STi)-43, DTC P0118 — ENGINE COOLANT TEMPERATURE CIRCUIT HIGH INPUT —, Diagnostic Trouble Code (DTC) Detecting Criteria.>

### • TROUBLE SYMPTOM:

- Hard to start
- Erroneous idling
- Poor driving performance

### CAUTION:

After repair or replacement of faulty parts, conduct Clear Memory Mode <Ref. to EN(STi)-42, OPERATION, Clear Memory Mode.> and Inspection Mode <Ref. to EN(STi)-35, OPERATION, Inspection Mode.>.

### • WIRING DIAGRAM:

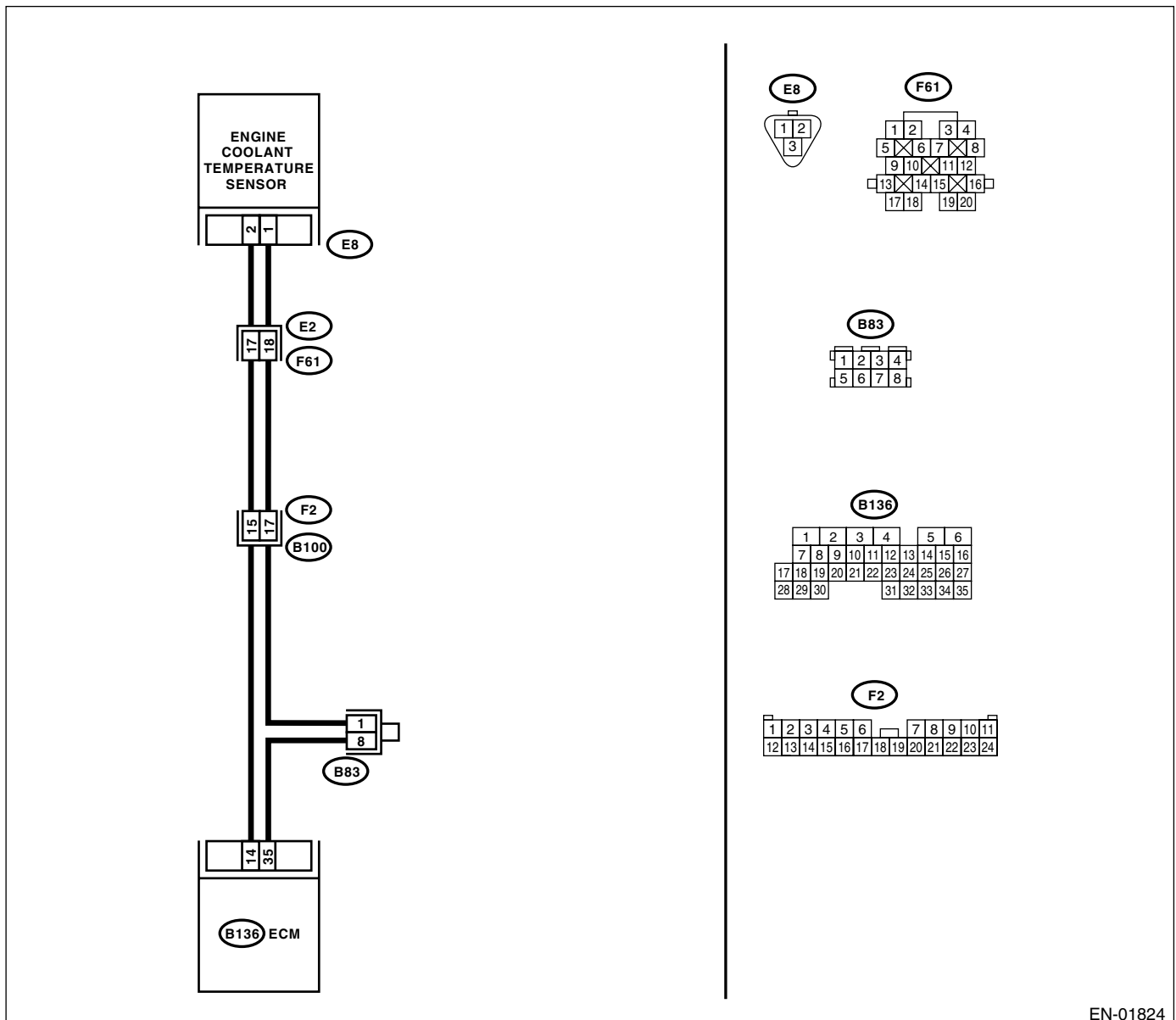

EN-01824

# DIAGNOSTIC PROCEDURE WITH DIAGNOSTIC TROUBLE CODE (DTC)

## ENGINE (DIAGNOSTICS)

Step	Check	Yes	No
<p><b>1 CHECK CURRENT DATA.</b>                      1) Start the engine.                      2) Read the data of engine coolant temperature sensor signal using Subaru Select Monitor or OBD-II general scan tool.</p> <p>NOTE:                      • Subaru Select Monitor                      For detailed operation procedure, refer to the "READ CURRENT DATA FOR ENGINE".                      &lt;Ref. to EN(STi)-28, Subaru Select Monitor.&gt;                      • OBD-II general scan tool                      For detailed operation procedures, refer to the OBD-II General Scan Tool Instruction Manual.</p>	<p>Is the temperature less than -40°C (-40°F)?</p>	<p>Go to step 2.</p>	<p>Repair the poor contact.</p> <p>NOTE:                      In this case, repair the following:</p> <ul style="list-style-type: none"> <li>• Poor contact in engine coolant temperature sensor</li> <li>• Poor contact in ECM</li> <li>• Poor contact in coupling connector</li> <li>• Poor contact in joint connector</li> </ul>
<p><b>2 CHECK HARNESS BETWEEN ENGINE COOLANT TEMPERATURE SENSOR AND ECM CONNECTOR.</b>                      1) Turn the ignition switch to OFF.                      2) Disconnect the connector from engine coolant temperature sensor.                      3) Measure the voltage between engine coolant temperature sensor connector and engine ground.</p> <p><b>Connector &amp; terminal</b>  <b>(E8) No. 2 (+) — Engine ground (-):</b></p>	<p>Is the voltage more than 10 V?</p>	<p>Repair the battery short circuit in harness between ECM and engine coolant temperature sensor connector.</p>	<p>Go to step 3.</p>
<p><b>3 CHECK HARNESS BETWEEN ENGINE COOLANT TEMPERATURE SENSOR AND ECM CONNECTOR.</b>                      1) Turn the ignition switch to ON.                      2) Measure the voltage between engine coolant temperature sensor connector and engine ground.</p> <p><b>Connector &amp; terminal</b>  <b>(E8) No. 2 (+) — Engine ground (-):</b></p>	<p>Is the voltage more than 10 V?</p>	<p>Repair the battery short circuit in harness between ECM and engine coolant temperature sensor connector.</p>	<p>Go to step 4.</p>
<p><b>4 CHECK HARNESS BETWEEN ENGINE COOLANT TEMPERATURE SENSOR AND ECM CONNECTOR.</b>                      Measure the voltage between engine coolant temperature sensor connector and engine ground.</p> <p><b>Connector &amp; terminal</b>  <b>(E8) No. 2 (+) — Engine ground (-):</b></p>	<p>Is the voltage more than 4 V?</p>	<p>Go to step 5.</p>	<p>Repair the harness and connector.</p> <p>NOTE:                      In this case, repair the following:</p> <ul style="list-style-type: none"> <li>• Open circuit in harness between ECM and engine coolant temperature sensor connector</li> <li>• Poor contact in engine coolant temperature sensor connector</li> <li>• Poor contact in ECM connector</li> <li>• Poor contact in coupling connector</li> <li>• Poor contact in joint connector</li> </ul>

# DIAGNOSTIC PROCEDURE WITH DIAGNOSTIC TROUBLE CODE (DTC)

ENGINE (DIAGNOSTICS)

Step	Check	Yes	No
<p><b>5</b></p> <p><b>CHECK HARNESS BETWEEN ENGINE COOLANT TEMPERATURE SENSOR AND ECM CONNECTOR.</b></p> <p>1) Turn the ignition switch to OFF.</p> <p>2) Measure the resistance of harness between engine coolant temperature sensor connector and engine ground.</p> <p><b>Connector &amp; terminal</b> <b>(E8) No. 1 — Engine ground:</b></p>	<p>Is the resistance less than 5 <math>\Omega</math>?</p>	<p>Replace the engine coolant temperature sensor. &lt;Ref. to FU(STi)-26, Engine Coolant Temperature Sensor.&gt;</p>	<p>Repair the harness and connector.</p> <p><b>NOTE:</b> In this case, repair the following:</p> <ul style="list-style-type: none"> <li>• Open circuit in harness between ECM and engine coolant temperature sensor connector</li> <li>• Poor contact in engine coolant temperature sensor connector</li> <li>• Poor contact in ECM connector</li> <li>• Poor contact in coupling connector</li> <li>• Poor contact in joint connector</li> </ul>

## DIAGNOSTIC PROCEDURE WITH DIAGNOSTIC TROUBLE CODE (DTC)

ENGINE (DIAGNOSTICS)

---

### **S: DTC P0122 — THROTTLE/PEDAL POSITION SENSOR/SWITCH “A” CIRCUIT LOW INPUT —**

#### **• DTC DETECTING CONDITION:**

- Immediately at fault recognition
- GENERAL DESCRIPTION <Ref. to GD(STi)-45, DTC P0122 — THROTTLE/PEDAL POSITION SENSOR/SWITCH “A” CIRCUIT LOW INPUT —, Diagnostic Trouble Code (DTC) Detecting Criteria.>

#### **• TROUBLE SYMPTOM:**

- Erroneous idling
- Engine stalls.
- Poor driving performance



# DIAGNOSTIC PROCEDURE WITH DIAGNOSTIC TROUBLE CODE (DTC) ENGINE (DIAGNOSTICS)

## • WIRING DIAGRAM:

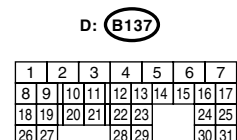
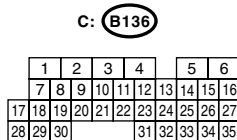
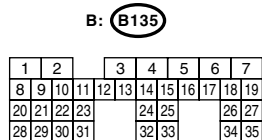
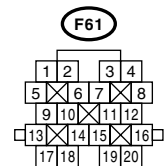
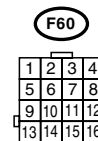
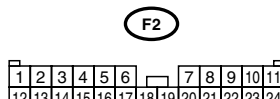
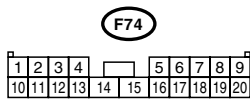
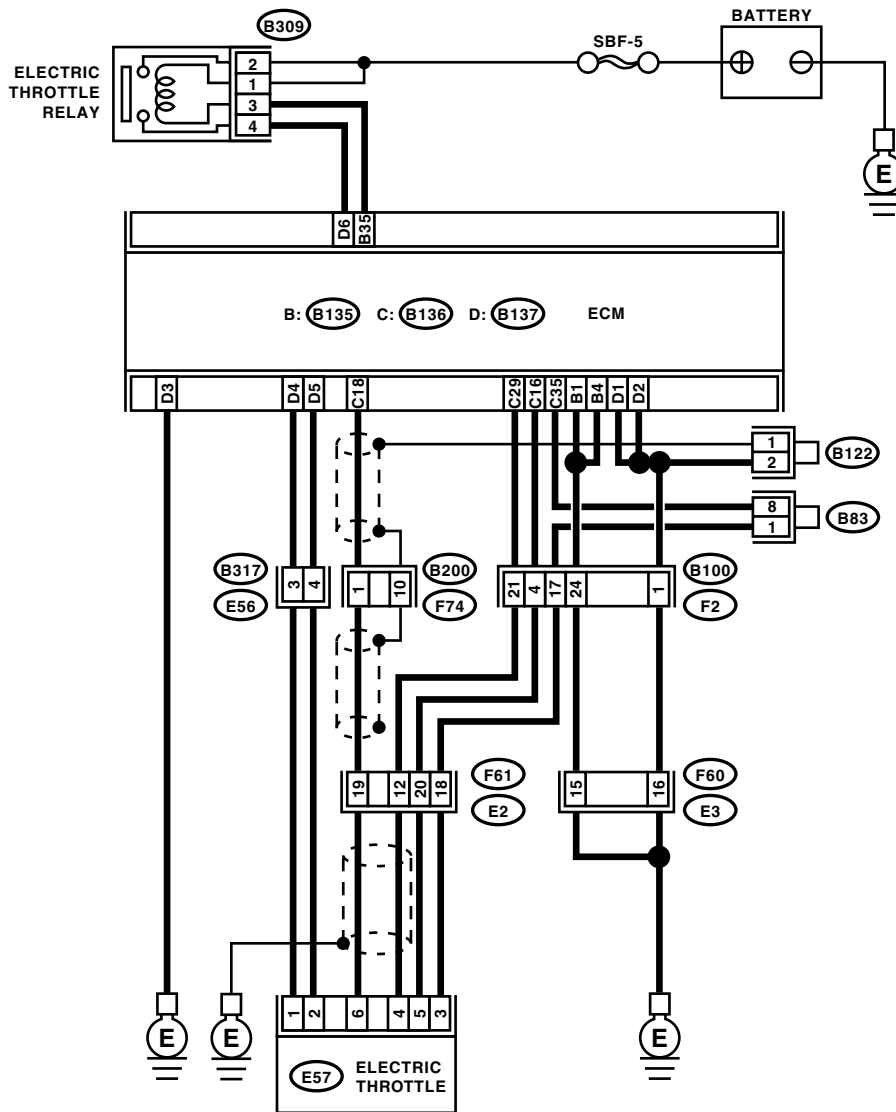

EN-01825

# DIAGNOSTIC PROCEDURE WITH DIAGNOSTIC TROUBLE CODE (DTC)

## ENGINE (DIAGNOSTICS)

Step	Check	Yes	No
<b>1 CHECK OUTPUT VOLTAGE OF SENSOR.</b> 1) Turn the ignition switch to ON. 2) Measure the voltage between ECM connector terminals. <i>Connector &amp; terminal</i> <i>(B136) No. 29 (+) — (B136) No. 35 (-) :</i> 3) Shake the ECM harness and connector, engine harness connectors and electric throttle.	Is the voltage more than 0.4 V?	Go to step 2.	Go to step 3.
<b>2 CHECK POOR CONTACT IN CONNECTORS.</b> Check poor contact in connectors between ECM and electric throttle.	Is there poor contact in the connectors between ECM and electric throttle?	Repair the poor contact in connectors.	Connector has returned to a normal condition at this time. A temporary poor contact of the connector may be the cause.
<b>3 CHECK HARNESS BETWEEN ECM AND ELECTRIC THROTTLE.</b> 1) Turn the ignition switch to OFF. 2) Disconnect the connector from ECM. 3) Disconnect the connector from electric throttle. 4) Measure the resistance between ECM connector and electric throttle connector. <i>Connector &amp; terminal</i> <i>(B136) No. 16 — (E57) No. 5:</i>	Is the resistance less than 1 $\Omega$ ?	Go to step 4.	Repair open of harness connector.
<b>4 CHECK HARNESS BETWEEN ECM AND ELECTRIC THROTTLE.</b> Measure the resistance between ECM connector and chassis ground. <i>Connector &amp; terminal</i> <i>(B136) No. 18 — Chassis ground:</i> <i>(B135) No. 16 — Chassis ground:</i>	Is the resistance more than 1 M $\Omega$ ?	Go to step 5.	Repair the chassis short of harness.
<b>5 CHECK POWER SUPPLY TO SENSOR.</b> 1) Connect the ECM connector. 2) Turn the ignition switch to ON. 3) Measure the voltage between electric throttle connector and engine ground. <i>Connector &amp; terminal</i> <i>(E57) No. 5 (+) — Engine ground (-):</i> 4) Shake the ECM harness and connector, engine harness connectors, while monitoring value of voltage meter.	Is the voltage 4.5 — 5.5 V?	Go to step 6.	Repair the poor contact in ECM connector. If problem persists, replace the ECM. <Ref. to FU(STi)-41, Engine Control Module (ECM).>
<b>6 CHECK SHORT OF ECM.</b> 1) Turn the ignition switch to OFF. 2) Measure the resistance between electric throttle connector and engine ground. <i>Connector &amp; terminal</i> <i>(E57) No. 6 — Engine ground:</i>	Is the resistance more than 10 $\Omega$ ?	Repair the poor contact in electric throttle connector. If problem persists, replace the accelerator position sensor.	Repair the poor the contact in ECM connector. If problem persists, replace the ECM. <Ref. to FU(STi)-41, Engine Control Module (ECM).>

## DIAGNOSTIC PROCEDURE WITH DIAGNOSTIC TROUBLE CODE (DTC)

ENGINE (DIAGNOSTICS)

### T: DTC P0123 — THROTTLE/PEDAL POSITION SENSOR/SWITCH “A” CIRCUIT HIGH INPUT —

- **DTC DETECTING CONDITION:**

- Immediately at fault recognition
- GENERAL DESCRIPTION <Ref. to GD(STi)-47, DTC P0123 — THROTTLE/PEDAL POSITION SENSOR/SWITCH “A” CIRCUIT HIGH INPUT —, Diagnostic Trouble Code (DTC) Detecting Criteria.>

- **TROUBLE SYMPTOM:**

- Erroneous idling
- Engine stalls.
- Poor driving performance

# DIAGNOSTIC PROCEDURE WITH DIAGNOSTIC TROUBLE CODE (DTC)

## ENGINE (DIAGNOSTICS)

### • WIRING DIAGRAM:

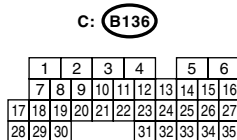
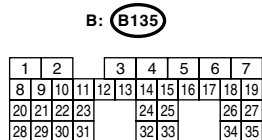
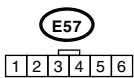
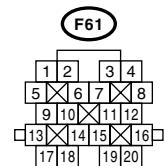
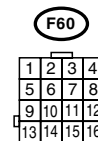
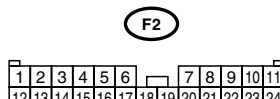
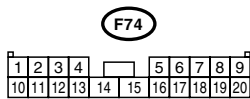
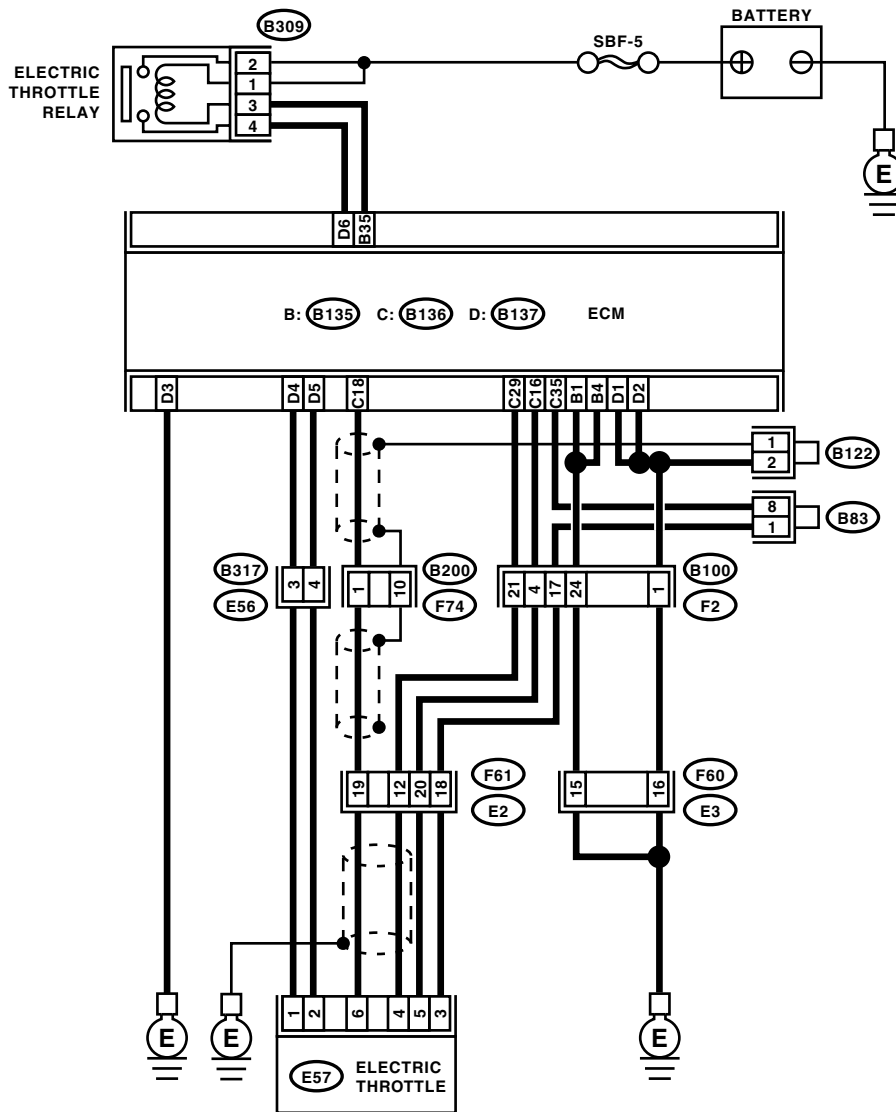

EN-01825

# DIAGNOSTIC PROCEDURE WITH DIAGNOSTIC TROUBLE CODE (DTC)

## ENGINE (DIAGNOSTICS)

Step	Check	Yes	No
<b>1 CHECK OUTPUT VOLTAGE OF SENSOR.</b> 1) Turn the ignition switch to ON. 2) Read the data of main throttle sensor signals, using the Subaru Select Monitor. 3) Shake the ECM harness and connector, engine harness connectors, electric throttle connector harness while monitoring value of voltage meter.	Is the voltage less than 4.63 V?	Go to step 2.	Go to step 3.
<b>2 CHECK POOR CONTACT IN CONNECTORS.</b> Check poor contact in connectors between ECM and electric throttle.	Is there poor contact in the connectors between ECM and electric throttle?	Repair the poor contact in connectors.	Connector has returned to a normal condition at this time. A temporary poor contact of the connector may be the cause.
<b>3 CHECK HARNESS BETWEEN ECM AND ELECTRIC THROTTLE.</b> 1) Turn the ignition switch to OFF. 2) Disconnect the connectors from ECM. 3) Disconnect the connectors from electric throttle. 4) Measure the resistance between ECM connector and electric throttle connector. <i><b>Connector &amp; terminal</b></i> <i><b>(B136) No. 18 — (E57) No. 6:</b></i> <i><b>(B136) No. 35 — (E57) No. 3:</b></i>	Is the resistance less than 1 $\Omega$ ?	Go to step 4.	Repair the open of harness connector.
<b>4 CHECK HARNESS BETWEEN ECM AND ELECTRIC THROTTLE.</b> 1) Connect the ECM connector. 2) Measure the resistance between the electric throttle connector and engine ground. <i><b>Connector &amp; terminal</b></i> <i><b>(E57) No. 3 — Engine ground:</b></i>	Is the resistance less than 1 $\Omega$ ?	Go to step 5.	Repair the poor contact in ECM connector. If the problem persists, replace the ECM. <Ref. to FU(STi)-41, Engine Control Module (ECM).>
<b>5 CHECK HARNESS BETWEEN ECM AND ELECTRIC THROTTLE.</b> 1) Turn the ignition switch to ON. 2) Measure the voltage between electric throttle connector and engine ground. <i><b>Connector &amp; terminal</b></i> <i><b>(E57) No. 5 (+) — Engine ground (-):</b></i> 3) Shake the ECM harness and connector, engine harness connectors, while monitoring value of voltage meter.	Is the voltage more than 10 V?	Go to step 6.	Repair the battery short of harness between ECM connector and electric throttle connector.
<b>6 CHECK POWER SUPPLY TO SENSOR.</b> 1) Measure the voltage between the electric throttle connector and engine ground. <i><b>Connector &amp; terminal</b></i> <i><b>(E57) No. 6 (+) — Engine ground (-):</b></i> 2) Shake the ECM harness and connector, engine harness connectors, while monitoring value of voltage meter.	Is the voltage less than 10 V?	Go to step 7.	Repair the short of harness between ECM connector and electric throttle connector.

# DIAGNOSTIC PROCEDURE WITH DIAGNOSTIC TROUBLE CODE (DTC)

ENGINE (DIAGNOSTICS)

	Step	Check	Yes	No
7	<b>CHECK HARNESS BETWEEN ECM AND ELECTRIC THROTTLE.</b> 1) Turn the ignition switch to OFF. 2) Disconnect the connector from ECM. 3) Measure the resistance between ECM connectors. <b>Connector &amp; terminal</b> <b>(B136) No. 18 — (B136) No. 16:</b>	Is the resistance more than 1 MΩ?	Repair the poor contact in harness. Replace the electric throttle.	Repair the short of harness of power supply to sensor.

# DIAGNOSTIC PROCEDURE WITH DIAGNOSTIC TROUBLE CODE (DTC)

ENGINE (DIAGNOSTICS)

## U: DTC P0125 — INSUFFICIENT COOLANT TEMPERATURE FOR CLOSED LOOP FUEL CONTROL —

### • DTC DETECTING CONDITION:

- Two consecutive driving cycles with fault
- GENERAL DESCRIPTION <Ref. to GD(STi)-49, DTC P0125 — INSUFFICIENT COOLANT TEMPERATURE FOR CLOSED LOOP FUEL CONTROL —, Diagnostic Trouble Code (DTC) Detecting Criteria.>

### • TROUBLE SYMPTOM:

- Engine will not return to idling.

### CAUTION:

After repair or replacement of faulty parts, conduct Clear Memory Mode <Ref. to EN(STi)-42, OPERATION, Clear Memory Mode.> and Inspection Mode <Ref. to EN(STi)-35, OPERATION, Inspection Mode.>.

### • WIRING DIAGRAM:

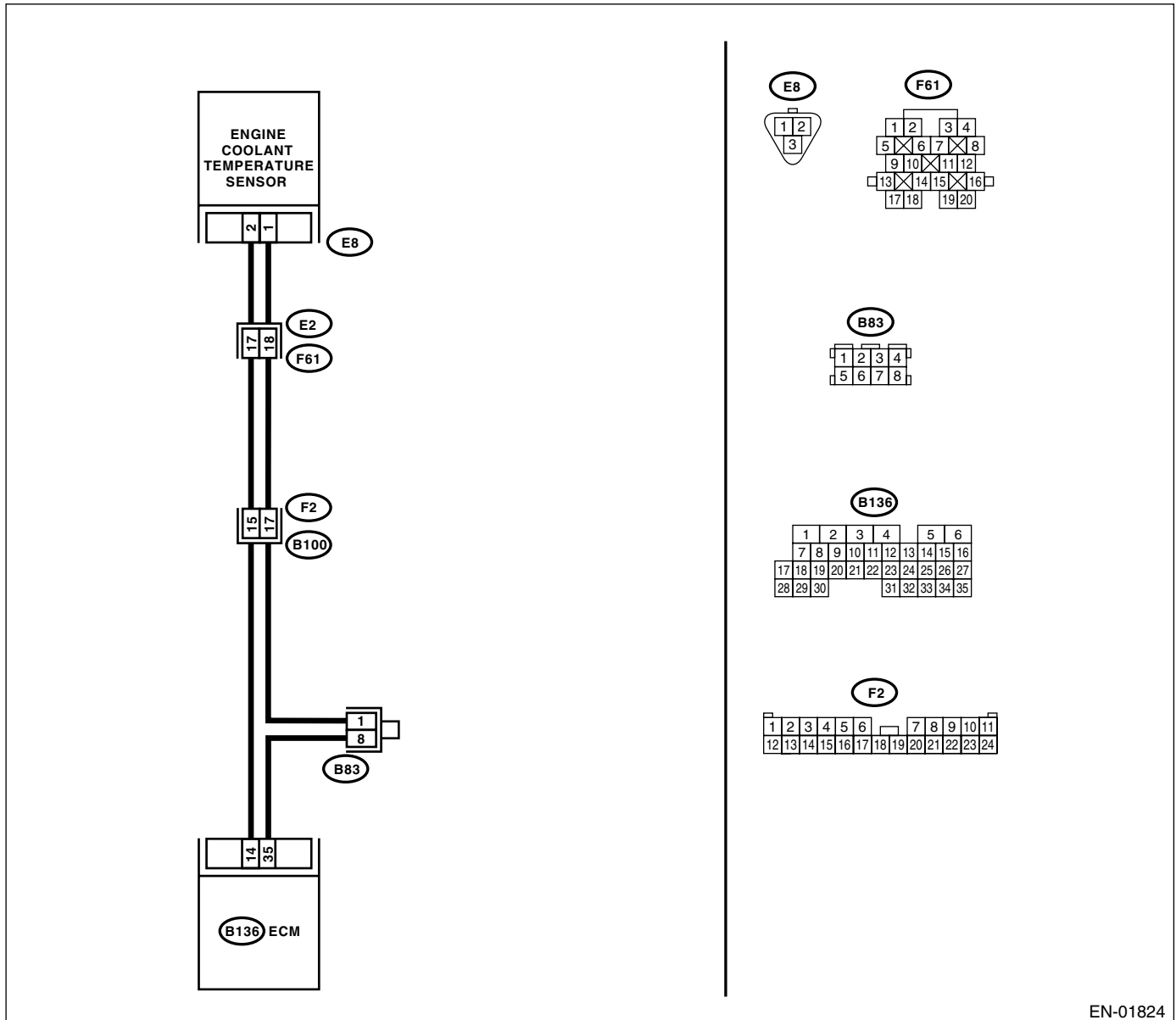

EN-01824

# DIAGNOSTIC PROCEDURE WITH DIAGNOSTIC TROUBLE CODE (DTC)

## ENGINE (DIAGNOSTICS)

	Step	Check	Yes	No
1	<b>CHECK ANY OTHER DTC ON DISPLAY.</b>	Is any other DTC displayed?	Inspect the relevant DTC using "List of Diagnostic Trouble Code (DTC)". <Ref. to EN(STi)-66, List of Diagnostic Trouble Code (DTC).>  NOTE: In this case, it is not necessary to inspect DTC P0125.	Go to step 2.
2	<b>CHECK ENGINE COOLING SYSTEM.</b>  NOTE: Check the following items. <ul style="list-style-type: none"><li>•Thermostat open stuck</li><li>•Coolant level</li><li>•Coolant freeze</li><li>•Tire diameter</li></ul>	Is there a fault in engine cooling system?	Replace the thermostat. <Ref. to CO(H4SO)-17, Thermostat.>	Replace the engine coolant temperature sensor. <Ref. to FU(STi)-26, Engine Coolant Temperature Sensor.>



# DIAGNOSTIC PROCEDURE WITH DIAGNOSTIC TROUBLE CODE (DTC)

ENGINE (DIAGNOSTICS)

## V: DTC P0128 — COOLANT THERMOSTAT (COOLANT TEMPERATURE BELOW THERMOSTAT REGULATING TEMPERATURE) —

### • DTC DETECTING CONDITION:

- Two consecutive driving cycles with fault
- GENERAL DESCRIPTION <Ref. to GD(STi)-51, DTC P0128 — COOLANT THERMOSTAT (COOLANT TEMPERATURE BELOW THERMOSTAT REGULATING TEMPERATURE) —, Diagnostic Trouble Code (DTC) Detecting Criteria.>

### • TROUBLE SYMPTOM:

- Thermostat remains open.

### CAUTION:

After repair or replacement of faulty parts, conduct Clear Memory Mode <Ref. to EN(STi)-42, OPERATION, Clear Memory Mode.> and Inspection Mode <Ref. to EN(STi)-35, OPERATION, Inspection Mode.>.

Step	Check	Yes	No	
1	<b>CHECK VEHICLE CONDITION.</b>	Was the vehicle driven or idled with the engine partially submerged under water?	In this case, it is not necessary to inspect DTC P0128.	Go to step 2.
2	<b>CHECK FOR OTHER DTC ON DISPLAY.</b>	Is any other DTC displayed?	Inspect the relevant DTC using "List of Diagnostic Trouble Codes (DTC)". <Ref. to EN(STi)-66, List of Diagnostic Trouble Code (DTC).>	Go to step 3.
3	<b>CHECK ENGINE COOLANT.</b>	Are coolant level and mixture ratio of cooling water to anti-freeze solution correct?	Go to step 4.	Replace the engine coolant. <Ref. to CO(H4SO)-12, REPLACEMENT, Engine Coolant.>
4	<b>CHECK RADIATOR FAN.</b> 1) Start the engine. 2) Check radiator fan operation.	Does the radiator fan continuously rotate for more than 3 minutes during idling?	Repair radiator fan circuit. <Ref. to CO(H4SO)-22, Radiator Main Fan and Fan Motor.> and <Ref. to CO(H4SO)-23, Radiator Sub Fan and Fan Motor.>	Replace the thermostat. <Ref. to CO(H4SO)-17, Thermostat.>

# DIAGNOSTIC PROCEDURE WITH DIAGNOSTIC TROUBLE CODE (DTC)

ENGINE (DIAGNOSTICS)

## W: DTC P0129 — ATMOSPHERIC PRESSURE SENSOR CIRCUIT RANGE/PERFORMANCE —

### • DTC DETECTING CONDITION:

- Two consecutive driving cycles with fault
- GENERAL DESCRIPTION <Ref. to GD(STi)-53, DTC P0129 — BAROMETRIC PRESSURE TOO LOW —, Diagnostic Trouble Code (DTC) Detecting Criteria.>

### CAUTION:

After repair or replacement of faulty parts, conduct Clear Memory Mode <Ref. to EN(STi)-42, OPERATION, Clear Memory Mode.> and Inspection Mode <Ref. to EN(STi)-35, OPERATION, Inspection Mode.>.

Step	Check	Yes	No
1 CHECK ANY OTHER DTC ON DISPLAY.	Is any other DTC displayed?	Replace the ECM. <Ref. to FU(STi)-41, Engine Control Module (ECM).> NOTE: Atmospheric pressure sensor is built into ECM.	NOTE: It is not necessary to inspect DTC P0129.

# DIAGNOSTIC PROCEDURE WITH DIAGNOSTIC TROUBLE CODE (DTC)

ENGINE (DIAGNOSTICS)

## X: DTC P0131 — O<sub>2</sub> SENSOR CIRCUIT LOW VOLTAGE (BANK 1 SENSOR 1) —

### • DTC DETECTING CONDITION:

- Immediately at fault recognition
- GENERAL DESCRIPTION <Ref. to GD(STi)-54, DTC P0131 — O<sub>2</sub> SENSOR CIRCUIT LOW VOLTAGE (BANK 1 SENSOR 1) —, Diagnostic Trouble Code (DTC) Detecting Criteria.>

### CAUTION:

After repair or replacement of faulty parts, conduct Clear Memory Mode <Ref. to EN(STi)-42, OPERATION, Clear Memory Mode.> and Inspection Mode <Ref. to EN(STi)-35, OPERATION, Inspection Mode.>.

### • WIRING DIAGRAM:

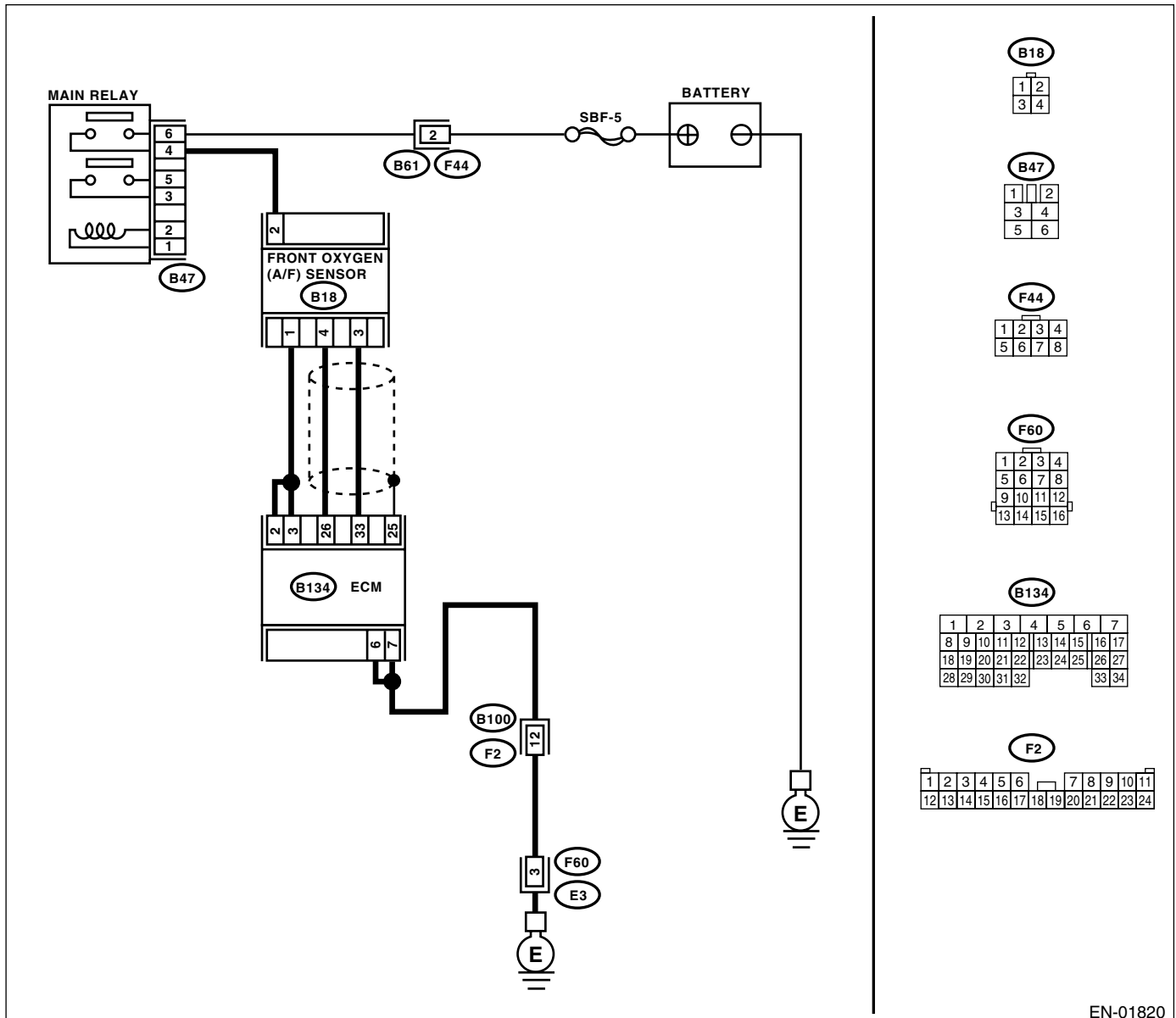

EN-01820

# DIAGNOSTIC PROCEDURE WITH DIAGNOSTIC TROUBLE CODE (DTC)

ENGINE (DIAGNOSTICS)

	Step	Check	Yes	No
1	<b>CHECK HARNESS BETWEEN ECM AND FRONT OXYGEN (A/F) SENSOR CONNECTOR.</b> 1) Turn the ignition switch to OFF. 2) Disconnect the connectors from ECM and front oxygen (A/F) sensor connector. 3) Measure the resistance of harness between ECM and front oxygen (A/F) sensor connector. <b>Connector &amp; terminal</b> <b>(B134) No. 26 — Chassis ground:</b> <b>(B134) No. 33 — Chassis ground:</b>	Is the resistance more than 1 MΩ?	Replace the front oxygen (A/F) sensor. <Ref. to FU(STi)-37, Front Oxygen (A/F) Sensor.>	Repair ground short circuit in harness between ECM and front oxygen (A/F) sensor connector.

# DIAGNOSTIC PROCEDURE WITH DIAGNOSTIC TROUBLE CODE (DTC)

ENGINE (DIAGNOSTICS)

## Y: DTC P0132 — O<sub>2</sub> SENSOR CIRCUIT HIGH VOLTAGE (BANK 1 SENSOR 1) —

### • DTC DETECTING CONDITION:

- Immediately at fault recognition
- GENERAL DESCRIPTION <Ref. to GD(STi)-56, DTC P0132 — O<sub>2</sub> SENSOR CIRCUIT HIGH VOLTAGE (BANK 1 SENSOR 1) —, Diagnostic Trouble Code (DTC) Detecting Criteria.>

### CAUTION:

After repair or replacement of faulty parts, conduct Clear Memory Mode <Ref. to EN(STi)-42, OPERATION, Clear Memory Mode.> and Inspection Mode <Ref. to EN(STi)-35, OPERATION, Inspection Mode.>.

### • WIRING DIAGRAM:

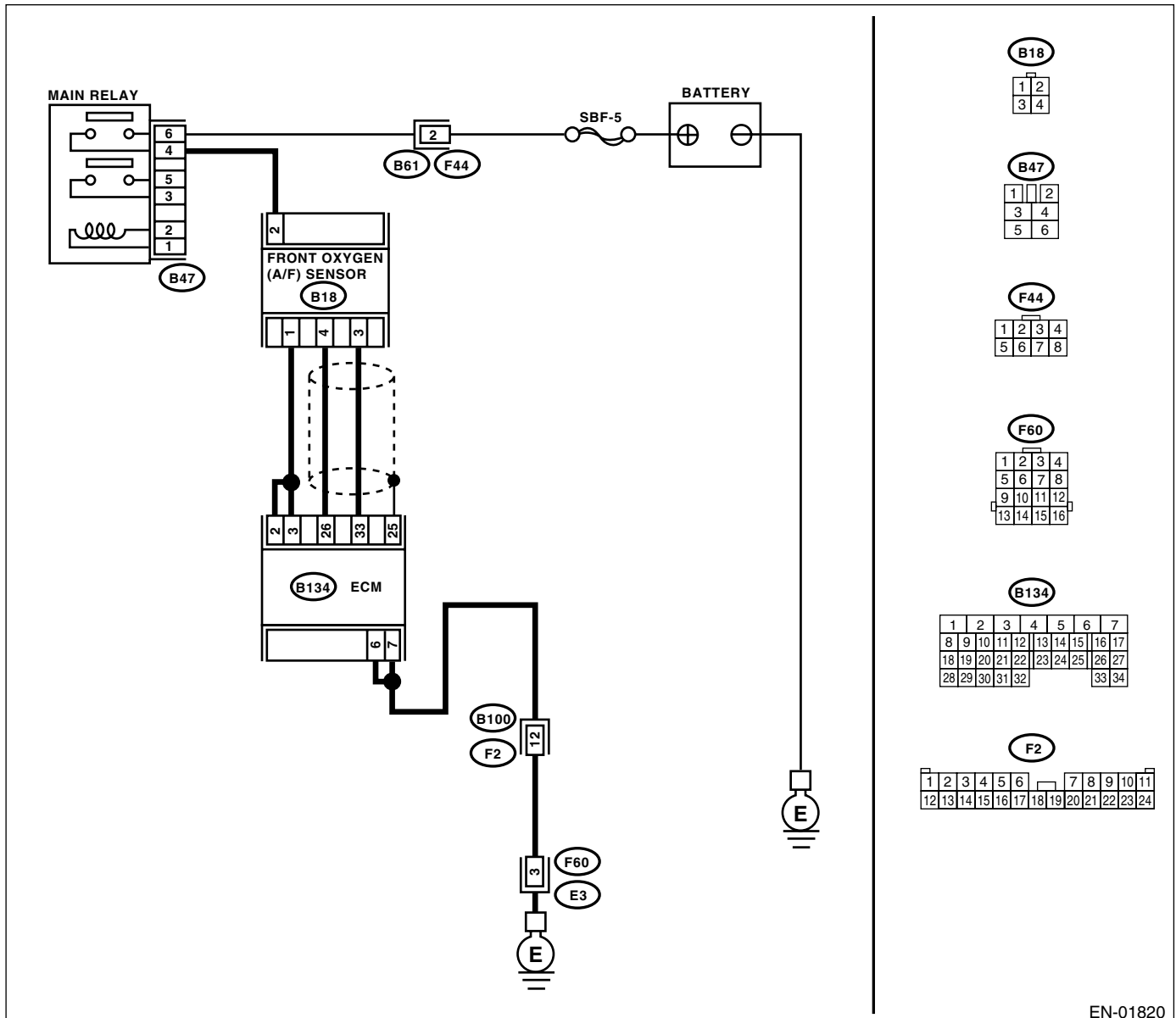

EN-01820

# DIAGNOSTIC PROCEDURE WITH DIAGNOSTIC TROUBLE CODE (DTC)

ENGINE (DIAGNOSTICS)

Step	Check	Yes	No
<p>1</p> <p><b>CHECK HARNESS BETWEEN ECM AND FRONT OXYGEN (A/F) SENSOR CONNECTOR.</b></p> <p>1) Turn the ignition switch to OFF.</p> <p>2) Disconnect the connectors from front oxygen (A/F) sensor.</p> <p>3) Measure the voltage of harness between ECM connector and chassis ground.</p> <p><b>Connector &amp; terminal</b></p> <p><b>(B134) No. 26 (+) — Chassis ground (-):</b></p> <p><b>(B134) No. 33 (+) — Chassis ground (-):</b></p>	<p>Is the voltage more than 8 V?</p>	<p>Replace the front oxygen (A/F) sensor. &lt;Ref. to FU(STi)-37, Front Oxygen (A/F) Sensor.&gt;</p>	<p>Repair battery short circuit in harness between ECM and front oxygen (A/F) sensor connector.</p>

# DIAGNOSTIC PROCEDURE WITH DIAGNOSTIC TROUBLE CODE (DTC)

ENGINE (DIAGNOSTICS)

## Z: DTC P0133 — O<sub>2</sub> SENSOR CIRCUIT SLOW RESPONSE (BANK 1 SENSOR 1)

**DTC DETECTING CONDITION:**

- Two consecutive driving cycles with fault
- GENERAL DESCRIPTION <Ref. to GD(STi)-58, DTC P0133 — O<sub>2</sub> SENSOR CIRCUIT SLOW RESPONSE (BANK 1 SENSOR 1) —, Diagnostic Trouble Code (DTC) Detecting Criteria.>

**CAUTION:**

After repair or replacement of faulty parts, conduct Clear Memory Mode <Ref. to EN(STi)-42, OPERATION, Clear Memory Mode.> and Inspection Mode <Ref. to EN(STi)-35, OPERATION, Inspection Mode.>.

**WIRING DIAGRAM:**

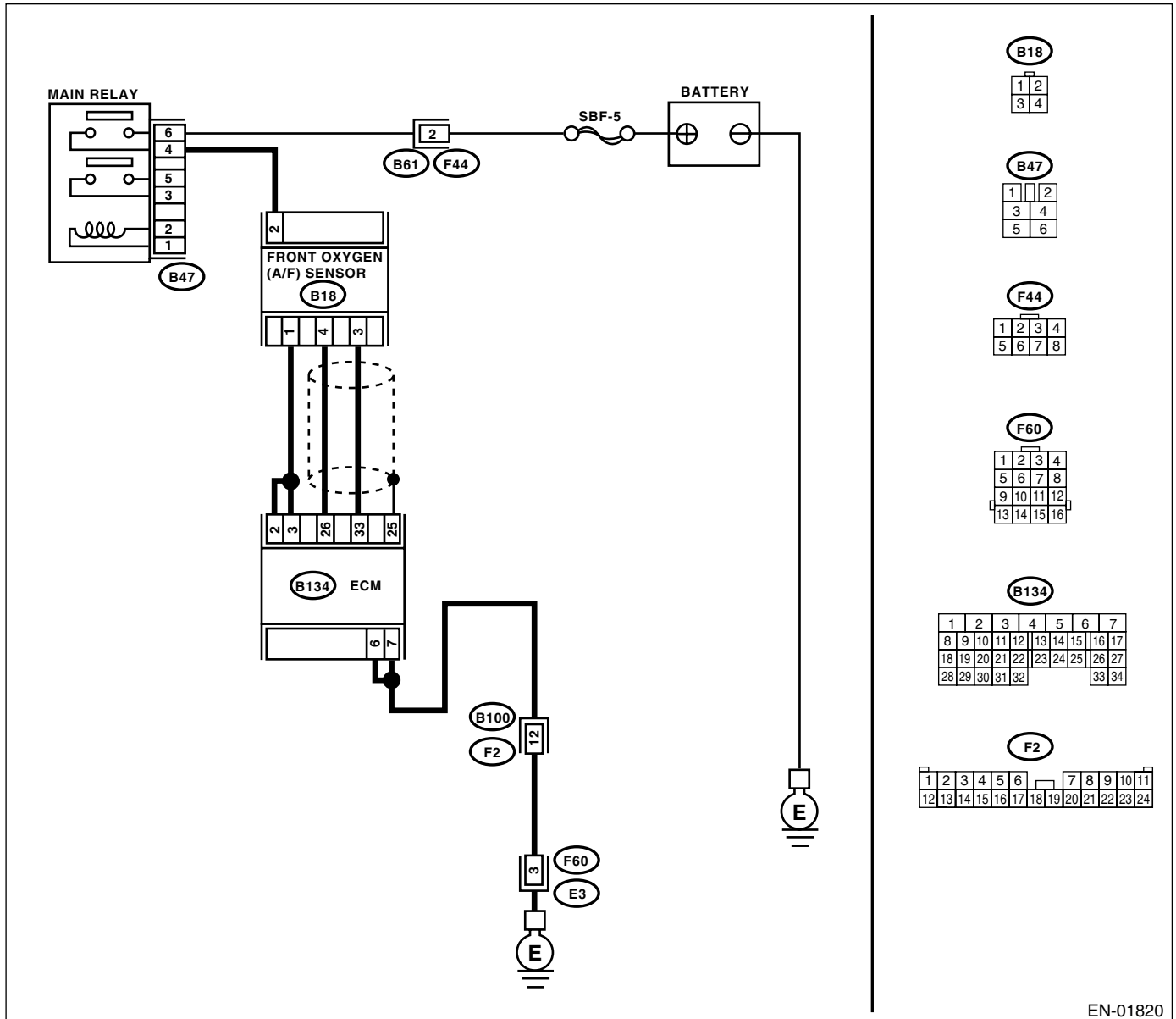

EN-01820

# DIAGNOSTIC PROCEDURE WITH DIAGNOSTIC TROUBLE CODE (DTC)

ENGINE (DIAGNOSTICS)

	Step	Check	Yes	No
1	<b>CHECK ANY OTHER DTC ON DISPLAY.</b>	Is any other DTC displayed?	Inspect the relevant DTC using "List of Diagnostic Trouble Code (DTC)". <Ref. to EN(STi)-66, List of Diagnostic Trouble Code (DTC).> NOTE: In this case, it is not necessary to inspect DTC P0133.	Go to step 2.
2	<b>CHECK EXHAUST SYSTEM.</b> NOTE: Check the following items. <ul style="list-style-type: none"><li>•Loose installation of front portion of exhaust pipe onto cylinder heads</li><li>•Loose connection between front exhaust pipe and front catalytic converter</li><li>•Damage of exhaust pipe resulting in a hole</li></ul>	Is there a fault in exhaust system?	Repair the exhaust system.	Replace the front oxygen (A/F) sensor. <Ref. to FU(STi)-37, Front Oxygen (A/F) Sensor.>



# DIAGNOSTIC PROCEDURE WITH DIAGNOSTIC TROUBLE CODE (DTC)

ENGINE (DIAGNOSTICS)

## AA: DTC P0134 — O<sub>2</sub> SENSOR CIRCUIT NO ACTIVITY DETECTED (BANK 1 SENSOR 1) —

### • DTC DETECTING CONDITION:

- Immediately at fault recognition
- GENERAL DESCRIPTION <Ref. to GD(STi)-61, DTC P0134 — O<sub>2</sub> SENSOR CIRCUIT NO ACTIVITY DETECTED (BANK 1 SENSOR 1) —, Diagnostic Trouble Code (DTC) Detecting Criteria.>

### CAUTION:

After repair or replacement of faulty parts, conduct Clear Memory Mode <Ref. to EN(STi)-42, OPERATION, Clear Memory Mode.> and Inspection Mode <Ref. to EN(STi)-35, OPERATION, Inspection Mode.>.

### • WIRING DIAGRAM:

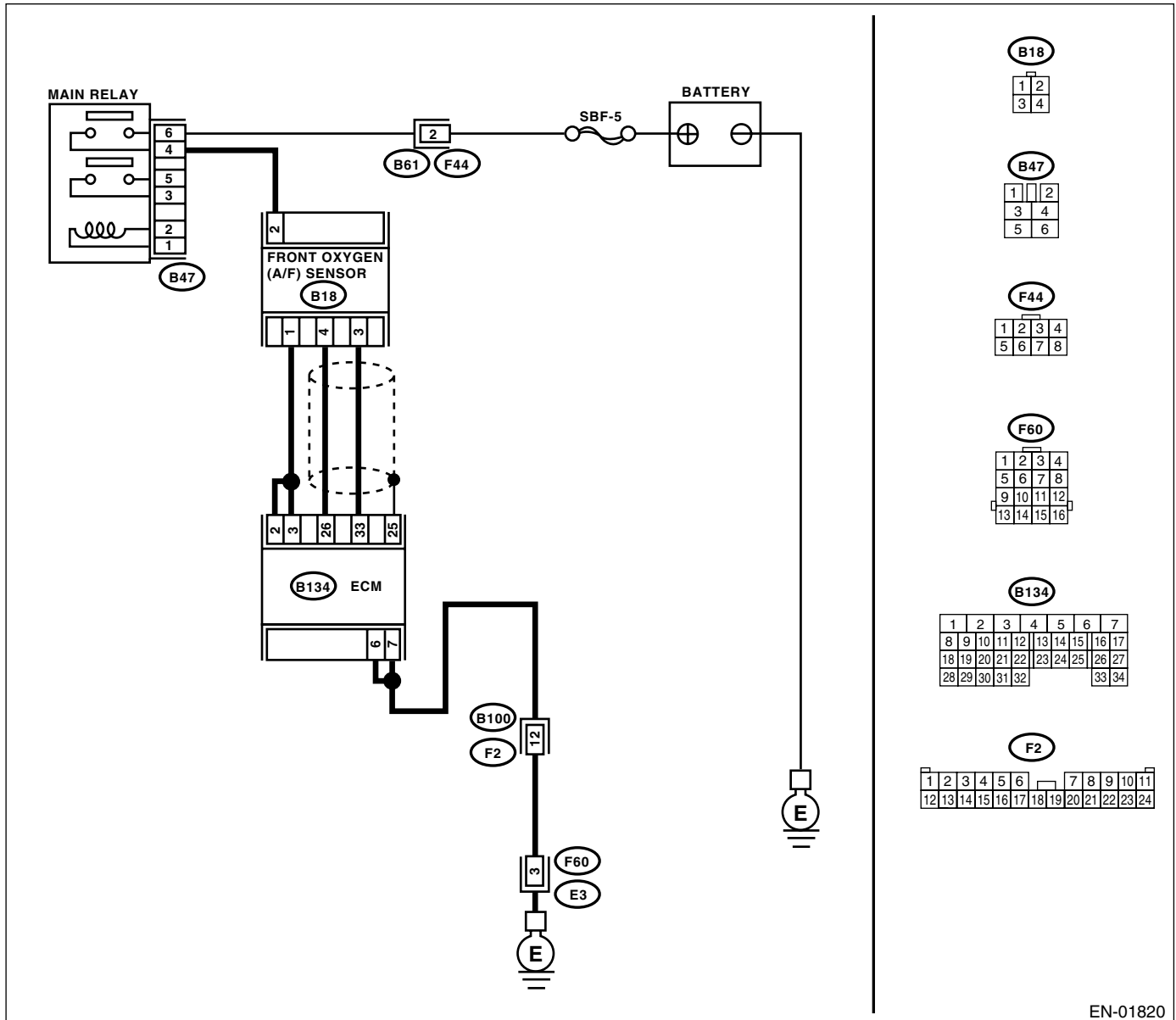

# DIAGNOSTIC PROCEDURE WITH DIAGNOSTIC TROUBLE CODE (DTC)

ENGINE (DIAGNOSTICS)

	Step	Check	Yes	No
1	<b>CHECK HARNESS BETWEEN ECM AND FRONT OXYGEN (A/F) SENSOR CONNECTOR.</b> 1) Turn the ignition switch to OFF. 2) Disconnect the connectors from ECM and front oxygen (A/F) sensor connector. 3) Measure the resistance of harness between ECM and front oxygen (A/F) sensor connector. <b>Connector &amp; terminal</b> <b>(B134) No. 26 — (B18) No. 4:</b> <b>(B134) No. 33 — (B18) No. 3:</b>	Is the resistance less than 1 $\Omega$ ?	Replace the front oxygen (A/F) sensor. <Ref. to FU(STi)-37, Front Oxygen (A/F) Sensor.>	Repair open circuit in harness between ECM and front oxygen (A/F) sensor connector.

# DIAGNOSTIC PROCEDURE WITH DIAGNOSTIC TROUBLE CODE (DTC)

## ENGINE (DIAGNOSTICS)

### AB:DTC P0137 — O<sub>2</sub> SENSOR CIRCUIT LOW VOLTAGE (BANK 1 SENSOR 2) —

**• DTC DETECTING CONDITION:**

- Two consecutive driving cycles with fault
- GENERAL DESCRIPTION <Ref. to GD(STi)-63, DTC P0137 — O<sub>2</sub> SENSOR CIRCUIT LOW VOLTAGE (BANK 1 SENSOR 2) —, Diagnostic Trouble Code (DTC) Detecting Criteria.>

**CAUTION:**

After repair or replacement of faulty parts, conduct Clear Memory Mode <Ref. to EN(STi)-42, OPERATION, Clear Memory Mode.> and Inspection Mode <Ref. to EN(STi)-35, OPERATION, Inspection Mode.>.

**• WIRING DIAGRAM:**

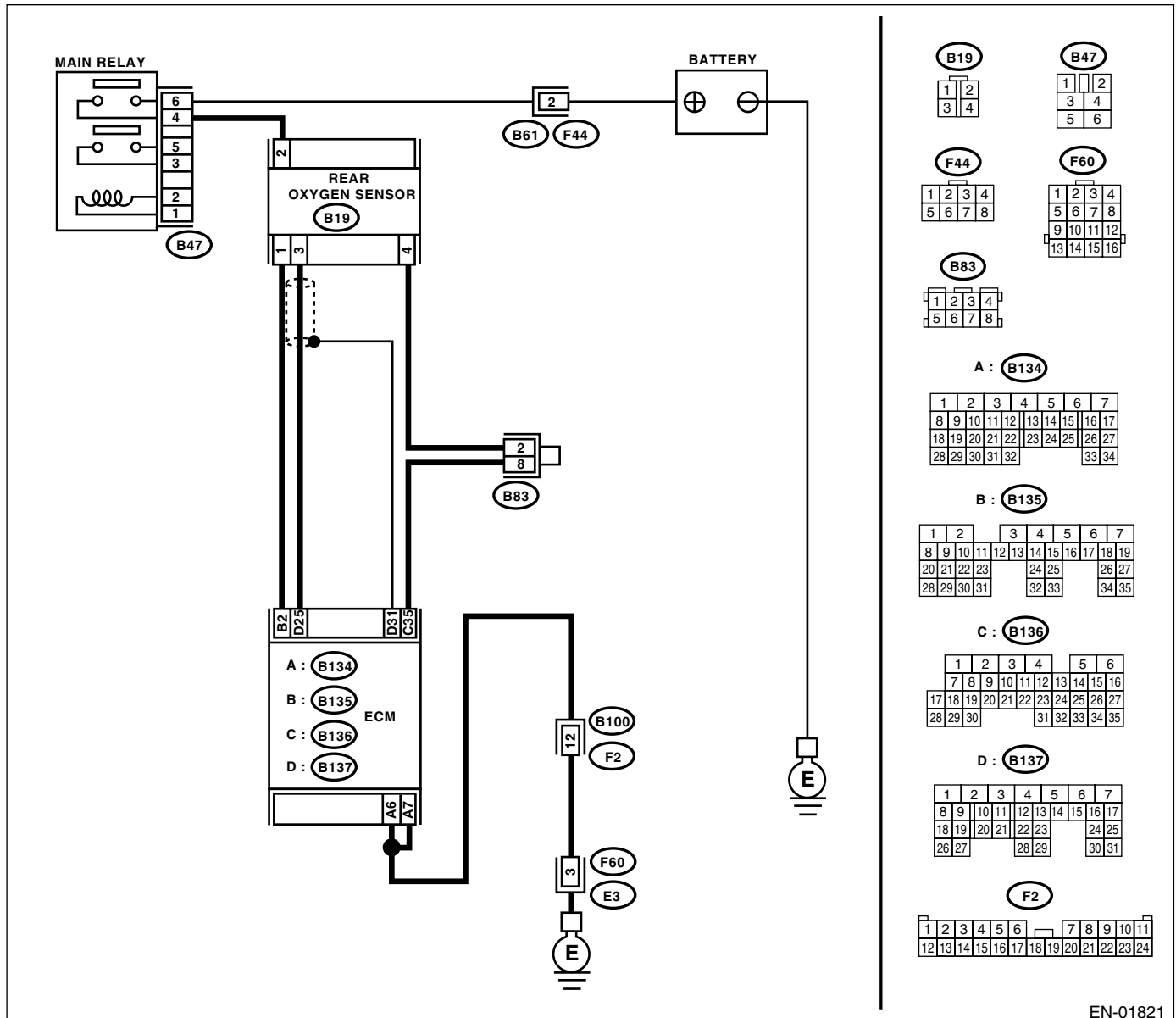

EN-01821

# DIAGNOSTIC PROCEDURE WITH DIAGNOSTIC TROUBLE CODE (DTC)

## ENGINE (DIAGNOSTICS)

	Step	Check	Yes	No
1	<b>CHECK ANY OTHER DTC ON DISPLAY.</b>	Is any other DTC displayed?	Using the List of Diagnostic Trouble Code (DTC), check the appropriate DTC. <Ref. to EN(STi)-66, List of Diagnostic Trouble Code (DTC).>	Go to step 2.
2	<b>CHECK REAR OXYGEN SENSOR DATA.</b> 1) Warm-up the engine until engine coolant temperature is above 70°C (158°F), and keep the engine speed at 2,000 rpm to 3,000 rpm for 2 minutes. 2) Read the data of rear oxygen sensor signal using Subaru Select Monitor or OBD-II general scan tool. <b>NOTE:</b> • Subaru Select Monitor For detailed operation procedure, refer to the "READ CURRENT DATA SHOWN ON DISPLAY FOR ENGINE". <Ref. to EN(STi)-28, Subaru Select Monitor.> • OBD-II general scan tool For detailed operation procedures, refer to the OBD-II General Scan Tool Instruction Manual.	Does the value fluctuate?	Go to step 6.	Go to step 3.
3	<b>CHECK REAR OXYGEN SENSOR DATA.</b> Read the data of rear oxygen sensor signal using Subaru Select Monitor or OBD-II general scan tool.	Is the voltage 0.2 — 0.4 V?	Go to step 4.	Replace the rear oxygen sensor. <Ref. to FU(STi)-39, Rear Oxygen Sensor.>
4	<b>CHECK HARNESS BETWEEN ECM AND REAR OXYGEN SENSOR CONNECTOR.</b> 1) Turn the ignition switch to OFF. 2) Disconnect the connectors from ECM and rear oxygen sensor. 3) Measure the resistance of harness between ECM and rear oxygen sensor connector. <b>Connector &amp; terminal</b> <b>(B137) No. 25 — (B19) No. 3:</b>	Is the resistance more than 3 Ω?	Repair the open circuit in harness between ECM and rear oxygen sensor connector.	Go to step 5.
5	<b>CHECK HARNESS BETWEEN REAR OXYGEN SENSOR AND ECM CONNECTOR.</b> 1) Turn the ignition switch to OFF. 2) Disconnect the connector from rear oxygen sensor. 3) Turn the ignition switch to ON. 4) Measure the voltage between rear oxygen sensor harness connector and engine ground or chassis ground. <b>Connector &amp; terminal</b> <b>(B19) No. 3 (+) — Engine ground (-):</b>	Is the voltage more than 0.2 V?	Replace the rear oxygen sensor. <Ref. to FU(STi)-39, Rear Oxygen Sensor.>	Repair the harness and connector. <b>NOTE:</b> In this case, repair the following: • Open circuit in harness between rear oxygen sensor and ECM connector • Poor contact in rear oxygen sensor connector • Poor contact in ECM connector

# DIAGNOSTIC PROCEDURE WITH DIAGNOSTIC TROUBLE CODE (DTC)

ENGINE (DIAGNOSTICS)

Step	Check	Yes	No
<b>6</b> <b>CHECK EXHAUST SYSTEM.</b> Check the exhaust system parts. <b>NOTE:</b> Check the following items. <ul style="list-style-type: none"><li>•Loose installation of portions</li><li>•Damage (crack, hole etc.) of parts</li><li>•Looseness and ill fitting of parts between front oxygen (A/F) sensor and rear oxygen sensor</li></ul>	Is there a fault in exhaust system?	Repair or replace the faulty parts.	Replace the rear oxygen sensor. <Ref. to FU(STi)-39, Rear Oxygen Sensor.>

# DIAGNOSTIC PROCEDURE WITH DIAGNOSTIC TROUBLE CODE (DTC)

ENGINE (DIAGNOSTICS)

## AC:DTC P0138 — O<sub>2</sub> SENSOR CIRCUIT HIGH VOLTAGE (BANK 1 SENSOR 2) —

### • DTC DETECTING CONDITION:

- Two consecutive driving cycles with fault
- GENERAL DESCRIPTION <Ref. to GD(STi)-66, DTC P0138 — O<sub>2</sub> SENSOR CIRCUIT HIGH VOLTAGE (BANK 1 SENSOR 2) —, Diagnostic Trouble Code (DTC) Detecting Criteria.>

### CAUTION:

After repair or replacement of faulty parts, conduct Clear Memory Mode <Ref. to EN(STi)-42, OPERATION, Clear Memory Mode.> and Inspection Mode <Ref. to EN(STi)-35, OPERATION, Inspection Mode.>.

### • WIRING DIAGRAM:

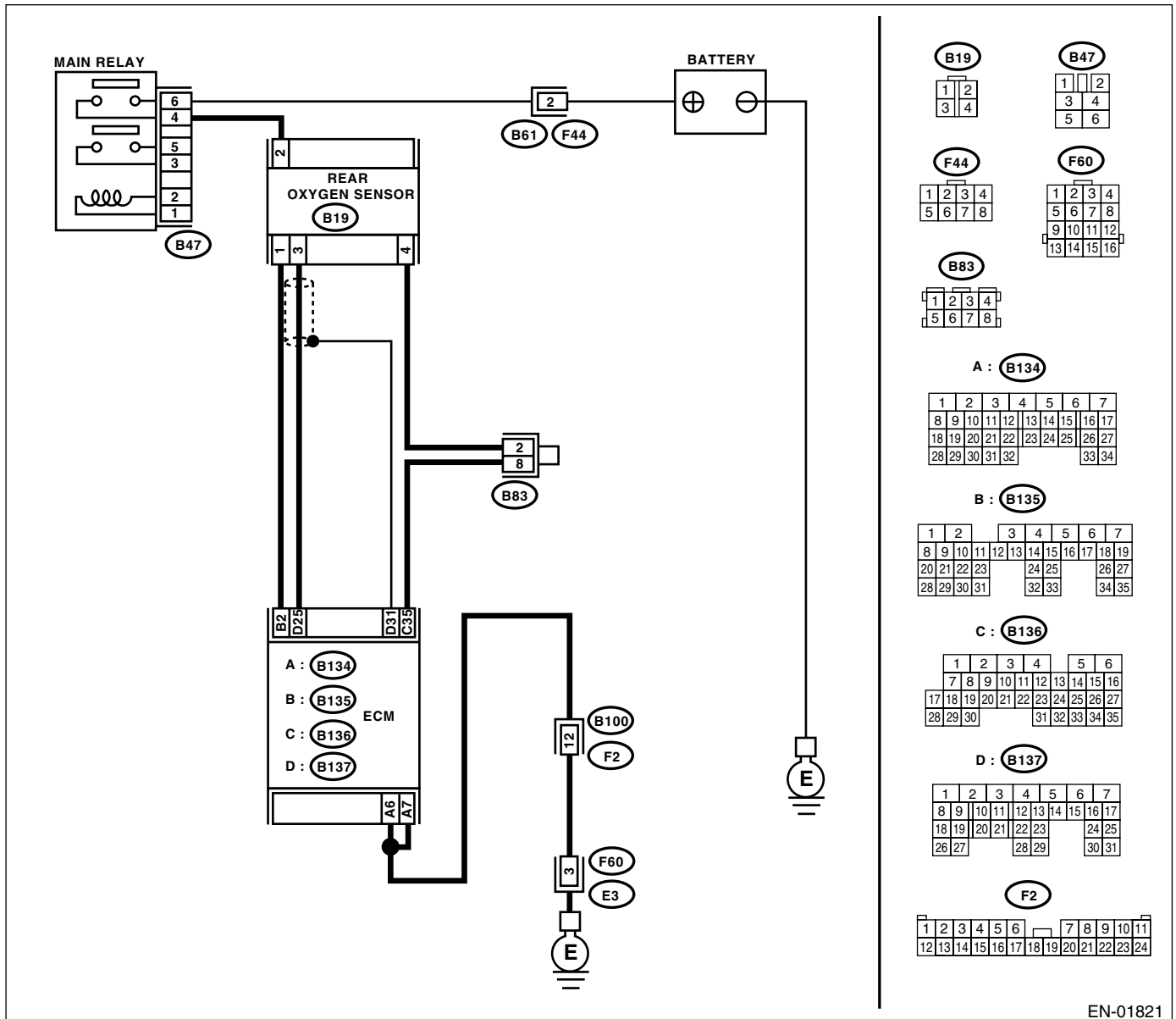

EN-01821

# DIAGNOSTIC PROCEDURE WITH DIAGNOSTIC TROUBLE CODE (DTC)

ENGINE (DIAGNOSTICS)

	Step	Check	Yes	No
1	<b>CHECK ANY OTHER DTC ON DISPLAY.</b>	Is any other DTC displayed?	Using the List of Diagnostic Trouble Code (DTC), check the appropriate DTC. <Ref. to EN(STi)-66, List of Diagnostic Trouble Code (DTC).>	Go to step 2.
2	<b>CHECK REAR OXYGEN SENSOR DATA.</b> 1) Warm-up the engine until engine coolant temperature is above 70°C (158°F), and keep the engine speed at 2,000 rpm to 3,000 rpm for 2 minutes. 2) Read the data of rear oxygen sensor signal using Subaru Select Monitor or OBD-II general scan tool. NOTE: • Subaru Select Monitor For detailed operation procedure, refer to the "READ CURRENT DATA SHOWN ON DISPLAY FOR ENGINE". <Ref. to EN(STi)-28, Subaru Select Monitor.> • OBD-II general scan tool For detailed operation procedures, refer to the OBD-II General Scan Tool Instruction Manual.	Does the value fluctuate?	Go to step 6.	Go to step 3.
3	<b>CHECK REAR OXYGEN SENSOR DATA.</b> Read the data of rear oxygen sensor signal using Subaru Select Monitor or OBD-II general scan tool.	Is the voltage 0.2 — 0.4 V?	Go to step 4.	Replace the rear oxygen sensor. <Ref. to FU(STi)-39, Rear Oxygen Sensor.>
4	<b>CHECK HARNESS BETWEEN ECM AND REAR OXYGEN SENSOR CONNECTOR.</b> 1) Turn the ignition switch to OFF. 2) Disconnect the connectors from ECM and rear oxygen sensor. 3) Measure the resistance of harness between ECM and rear oxygen sensor connector. <b>Connector &amp; terminal</b> <b>(B137) No. 25 — (B19) No. 3:</b>	Is the resistance more than 3 Ω?	Repair the open circuit in harness between ECM and rear oxygen sensor connector.	Go to step 5.
5	<b>CHECK HARNESS BETWEEN REAR OXYGEN SENSOR AND ECM CONNECTOR.</b> 1) Turn the ignition switch to OFF. 2) Disconnect the connector from rear oxygen sensor. 3) Turn the ignition switch to ON. 4) Measure the voltage between rear oxygen sensor harness connector and engine ground or chassis ground. <b>Connector &amp; terminal</b> <b>(B19) No. 3 (+) — Engine ground (-):</b>	Is the voltage more than 0.2 V?	Replace the rear oxygen sensor. <Ref. to FU(STi)-39, Rear Oxygen Sensor.>	Repair the harness and connector. NOTE: In this case, repair the following: • Open circuit in harness between rear oxygen sensor and ECM connector • Poor contact in rear oxygen sensor connector • Poor contact in ECM connector

# DIAGNOSTIC PROCEDURE WITH DIAGNOSTIC TROUBLE CODE (DTC)

ENGINE (DIAGNOSTICS)

	Step	Check	Yes	No
6	<b>CHECK EXHAUST SYSTEM.</b> Check the exhaust system parts. <b>NOTE:</b> Check the following items. <ul style="list-style-type: none"><li>•Loose installation of portions</li><li>•Damage (crack, hole etc.) of parts</li><li>•Looseness and ill fitting of parts between front oxygen (A/F) sensor and rear oxygen sensor</li></ul>	Is there a fault in exhaust system?	Repair or replace the faulty parts.	Replace the rear oxygen sensor. <Ref. to FU(STi)-39, Rear Oxygen Sensor.>



# DIAGNOSTIC PROCEDURE WITH DIAGNOSTIC TROUBLE CODE (DTC)

ENGINE (DIAGNOSTICS)

## AD:DTC P0139 — O<sub>2</sub> SENSOR CIRCUIT SLOW RESPONSE (BANK 1 SENSOR 2)

### DTC DETECTING CONDITION:

- Two consecutive driving cycles with fault
- GENERAL DESCRIPTION <Ref. to GD(STi)-68, DTC P0139 — O<sub>2</sub> SENSOR CIRCUIT SLOW RESPONSE (BANK 1 SENSOR 2) —, Diagnostic Trouble Code (DTC) Detecting Criteria.>

### CAUTION:

After repair or replacement of faulty parts, conduct Clear Memory Mode <Ref. to EN(STi)-42, OPERATION, Clear Memory Mode.> and Inspection Mode <Ref. to EN(STi)-35, OPERATION, Inspection Mode.>.

### WIRING DIAGRAM:

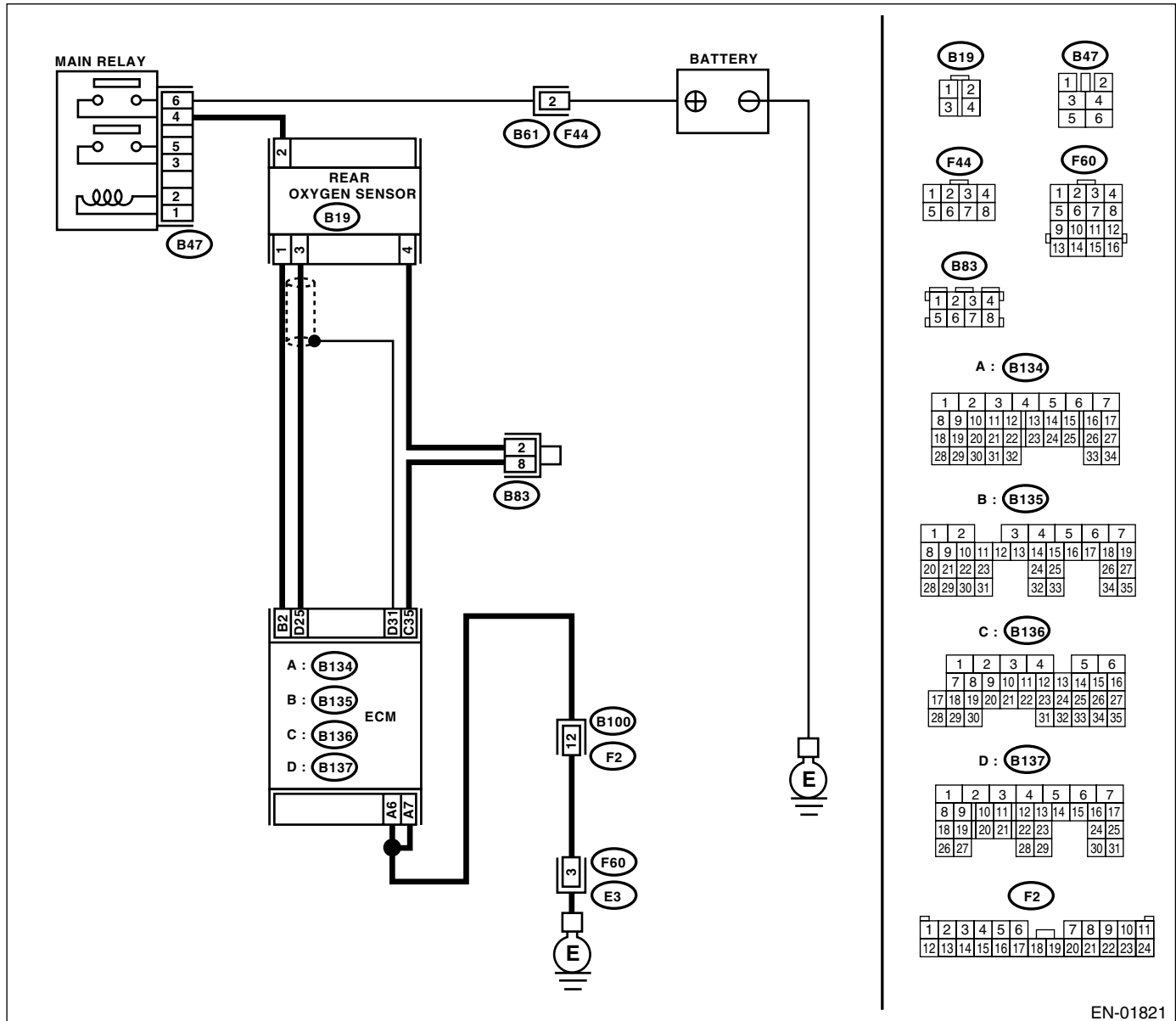

EN-01821

# DIAGNOSTIC PROCEDURE WITH DIAGNOSTIC TROUBLE CODE (DTC)

ENGINE (DIAGNOSTICS)

	Step	Check	Yes	No
1	<b>CHECK ANY OTHER DTC ON DISPLAY.</b>	Is any other DTC displayed?	Inspect the relevant DTC using "List of Diagnostic Trouble Code (DTC)". <Ref. to EN(STi)-66, List of Diagnostic Trouble Code (DTC).>  NOTE: In this case, it is not necessary to inspect DTC P0139.	Replace the rear oxygen sensor. <Ref. to FU(STi)-39, Rear Oxygen Sensor.>

## AE:DTC P0171 — SYSTEM TOO LEAN (BANK 1) —

NOTE:

For the diagnostic procedure, refer to DTC P0172. <Ref. to EN(STi)-139, DTC P0172 — SYSTEM TOO RICH (BANK 1) —, Diagnostic Procedure with Diagnostic Trouble Code (DTC).>

# DIAGNOSTIC PROCEDURE WITH DIAGNOSTIC TROUBLE CODE (DTC)

ENGINE (DIAGNOSTICS)

## AF:DTC P0172 — SYSTEM TOO RICH (BANK 1) —

### • DTC DETECTING CONDITION:

- Two consecutive driving cycles with fault
- GENERAL DESCRIPTION <Ref. to GD(STi)-71, DTC P0171 — SYSTEM TOO LEAN (BANK 1) —, Diagnostic Trouble Code (DTC) Detecting Criteria.> and <Ref. to GD(STi)-74, DTC P0172 — SYSTEM TOO RICH (BANK 1) —, Diagnostic Trouble Code (DTC) Detecting Criteria.>

### • TROUBLE SYMPTOM:

- Erroneous idling
- Engine stalls.
- Poor driving performance

### CAUTION:

After repair or replacement of faulty parts, conduct Clear Memory Mode <Ref. to EN(STi)-42, OPERATION, Clear Memory Mode.> and Inspection Mode <Ref. to EN(STi)-35, OPERATION, Inspection Mode.>.

Step	Check	Yes	No
1	<b>CHECK EXHAUST SYSTEM.</b>	Are there holes or loose bolts on exhaust system?	Repair the exhaust system. Go to step 2.
2	<b>CHECK AIR INTAKE SYSTEM.</b>	Are there holes, loose bolts or disconnection of hose on air intake system?	Repair the air intake system. Go to step 3.
3	<b>CHECK FUEL PRESSURE.</b> <b>Warning:</b> •Place “NO FIRE” signs near the working area. •Be careful not to spill fuel on the floor. 1)Release the fuel pressure. (1) Disconnect the connector from fuel pump relay. (2) Start the engine and run it until it stalls. (3) After the engine stalls, crank it for 5 more seconds. (4) Turn the ignition switch to OFF. 2)Connect the connector to fuel pump relay. 3)Disconnect the fuel delivery hose from fuel filter, and connect fuel pressure gauge. 4)Install the fuel filler cap. 5)Start the engine and idle while gear position is neutral. 6)Measure the fuel pressure while disconnecting pressure regulator vacuum hose from intake manifold. <b>Warning:</b> <b>Before removing the fuel pressure gauge, release fuel pressure.</b> <b>NOTE:</b> If the fuel pressure does not increase, squeeze fuel return hose 2 to 3 times, then measure fuel pressure again.	Is the measured value 284 — 314 kPa (2.9 — 3.2 kg/cm <sup>2</sup> , 41 — 46 psi)?	Go to step 4.  Repair the following items. Fuel pressure too high: • Clogged fuel return line or bent hose Fuel pressure too low: • Improper fuel pump discharge • Clogged fuel supply line

# DIAGNOSTIC PROCEDURE WITH DIAGNOSTIC TROUBLE CODE (DTC)

## ENGINE (DIAGNOSTICS)

	Step	Check	Yes	No
<p><b>4</b></p> <p><b>CHECK FUEL PRESSURE.</b> After connecting the pressure regulator vacuum hose, measure fuel pressure.</p> <p><b>Warning:</b> <b>Before removing the fuel pressure gauge, release fuel pressure.</b></p> <p><b>NOTE:</b></p> <ul style="list-style-type: none"> <li>•If the fuel pressure does not increase, squeeze fuel return hose 2 to 3 times, then measure fuel pressure again.</li> <li>•If out of specification as measured at this step, check or replace the pressure regulator and pressure regulator vacuum hose.</li> </ul>	<p>Is the measured value 206 — 235 kPa (2.1 — 2.4 kg/cm<sup>2</sup>, 30 — 34 psi)?</p>	<p>Go to step 5.</p>	<p>Repair the following items.</p> <p>Fuel pressure too high:</p> <ul style="list-style-type: none"> <li>• Faulty pressure regulator</li> <li>• Clogged fuel return line or bent hose</li> </ul> <p>Fuel pressure too low:</p> <ul style="list-style-type: none"> <li>• Faulty pressure regulator</li> <li>• Improper fuel pump discharge</li> <li>• Clogged fuel supply line</li> </ul>	
<p><b>5</b></p> <p><b>CHECK ENGINE COOLANT TEMPERATURE SENSOR.</b></p> <p>1)Start the engine and warm-up completely. 2)Read the data of engine coolant temperature sensor signal using Subaru Select Monitor or OBD-II general scan tool.</p> <p><b>NOTE:</b></p> <ul style="list-style-type: none"> <li>•Subaru Select Monitor</li> </ul> <p>For detailed operation procedure, refer to the “READ CURRENT DATA FOR ENGINE”. &lt;Ref. to EN(STi)-28, Subaru Select Monitor.&gt;</p> <ul style="list-style-type: none"> <li>•OBD-II general scan tool</li> </ul> <p>For detailed operation procedures, refer to the OBD-II General Scan Tool Instruction Manual.</p>	<p>Is the temperature more than 60°C (140°F)?</p>	<p>Go to step 6.</p>	<p>Replace the engine coolant temperature sensor. &lt;Ref. to FU(STi)-26, Engine Coolant Temperature Sensor.&gt;</p>	
<p><b>6</b></p> <p><b>CHECK MASS AIR FLOW AND INTAKE AIR TEMPERATURE.</b></p> <p>1)Start the engine and warm-up engine until coolant temperature is greater than 60°C (140°F). 2)Place the shift lever in neutral position. 3)Turn the A/C switch to OFF. 4)Turn all accessory switches to OFF. 5)Read the data of mass air flow and intake air temperature sensor signal using Subaru Select Monitor or OBD-II general scan tool.</p> <p><b>NOTE:</b></p> <ul style="list-style-type: none"> <li>•Subaru Select Monitor</li> </ul> <p>For detailed operation procedure, refer to the “READ CURRENT DATA FOR ENGINE”. &lt;Ref. to EN(STi)-28, Subaru Select Monitor.&gt;</p> <ul style="list-style-type: none"> <li>•OBD-II general scan tool</li> </ul> <p>For detailed operation procedure, refer to the OBD-II General Scan Tool Instruction Manual.</p>	<p>Is the measured value within the followings? Ignition ON: 73.3 — 106.6 kPa (550 — 800 mmHg, 21.65 — 31.50 inHg) Idling: 24.0 — 41.3 kPa (180 — 310 mmHg, 7.09 — 12.20 inHg)</p>	<p>Go to step 7.</p>	<p>Replace the mass air flow and intake air temperature sensor. &lt;Ref. to FU(STi)-30, Mass Air Flow and Intake Air Temperature Sensor.&gt;</p>	

# DIAGNOSTIC PROCEDURE WITH DIAGNOSTIC TROUBLE CODE (DTC)

ENGINE (DIAGNOSTICS)

Step	Check	Yes	No
<p><b>7</b>     <b>CHECK MASS AIR FLOW AND INTAKE AIR TEMPERATURE SENSOR.</b></p> <p>1) Start the engine and warm-up engine until coolant temperature is greater than 60°C (140°F).</p> <p>2) Place the shift lever in neutral position.</p> <p>3) Turn the A/C switch to OFF.</p> <p>4) Turn all accessory switches to OFF.</p> <p>5) Open the front hood.</p> <p>6) Measure the ambient temperature.</p> <p>7) Read the data of mass air flow and intake air temperature sensor signal using Subaru Select Monitor or OBD-II general scan tool.</p> <p><b>NOTE:</b></p> <ul style="list-style-type: none"> <li>• Subaru Select Monitor</li> </ul> <p>For detailed operation procedure, refer to the "READ CURRENT DATA FOR ENGINE".</p> <p>&lt;Ref. to EN(STi)-28, Subaru Select Monitor.&gt;</p> <ul style="list-style-type: none"> <li>• OBD-II general scan tool</li> </ul> <p>For detailed operation procedure, refer to the OBD-II General Scan Tool Instruction Manual.</p>	<p>Subtract ambient temperature from intake air temperature.</p> <p>Is the obtained value -10°C — 50°C (14°F — 122°F)?</p>	<p>Contact your SOA Service Center.</p> <p><b>NOTE:</b></p> <p>Inspection by DTM is required, because probable cause is deterioration of multiple parts.</p>	<p>Check the mass air flow and intake air temperature sensor. &lt;Ref. to FU(STi)-30, Mass Air Flow and Intake Air Temperature Sensor.&gt;</p>

# DIAGNOSTIC PROCEDURE WITH DIAGNOSTIC TROUBLE CODE (DTC)

ENGINE (DIAGNOSTICS)

## AG:DTC P0181 — FUEL TEMPERATURE SENSOR “A” CIRCUIT RANGE/PERFORMANCE —

### • DTC DETECTING CONDITION:

- Two consecutive driving cycles with fault
- GENERAL DESCRIPTION <Ref. to GD(STi)-77, DTC P0181 — FUEL TEMPERATURE SENSOR “A” CIRCUIT RANGE/PERFORMANCE —, Diagnostic Trouble Code (DTC) Detecting Criteria.>

### CAUTION:

After repair or replacement of faulty parts, conduct Clear Memory Mode <Ref. to EN(STi)-42, OPERATION, Clear Memory Mode.> and Inspection Mode <Ref. to EN(STi)-35, OPERATION, Inspection Mode.>.

### • WIRING DIAGRAM:

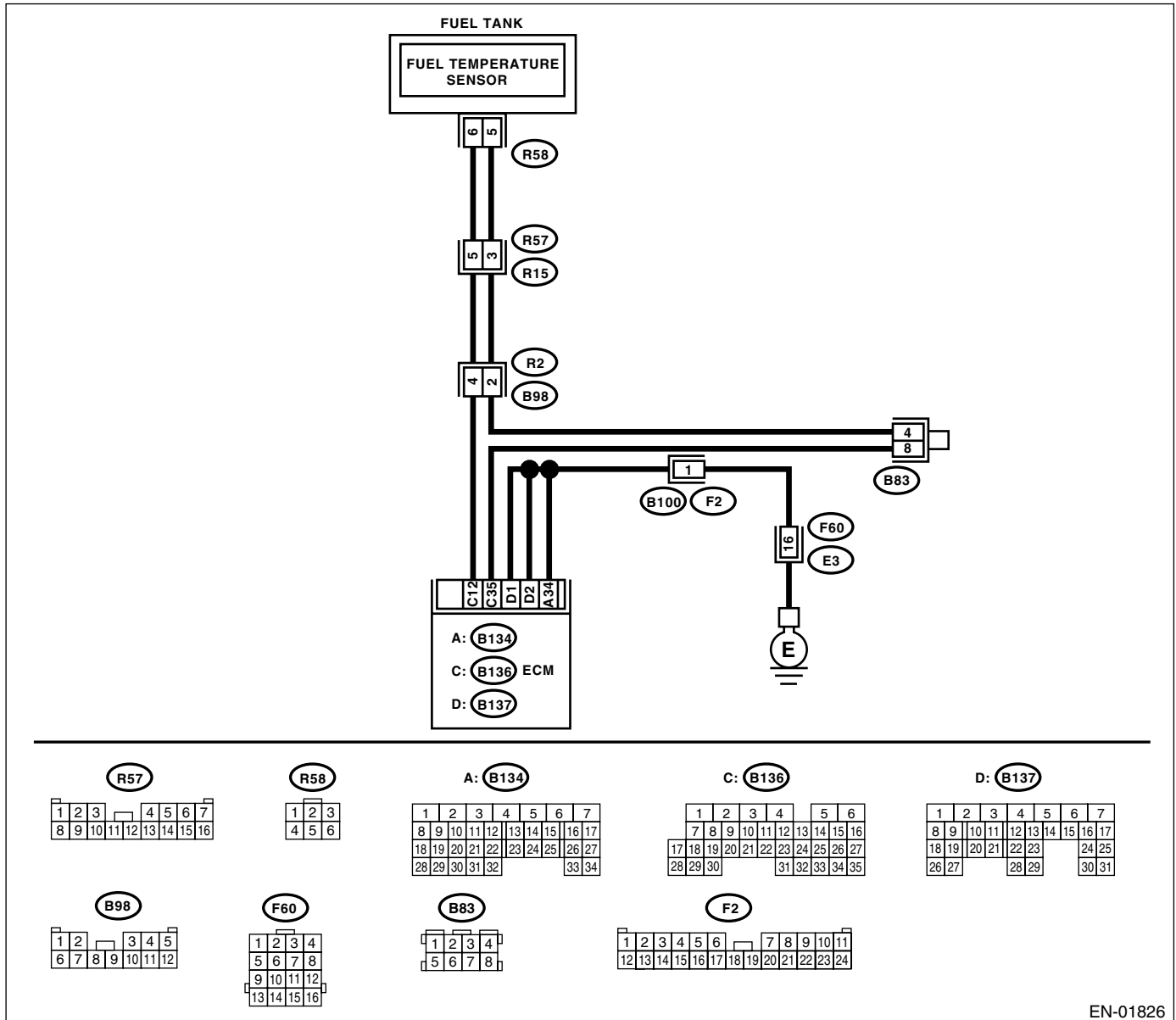

# DIAGNOSTIC PROCEDURE WITH DIAGNOSTIC TROUBLE CODE (DTC)

ENGINE (DIAGNOSTICS)

	Step	Check	Yes	No
1	<b>CHECK FOR OTHER DTC ON DISPLAY.</b>	Is any other DTC displayed?	Inspect the relevant DTC using "List of Diagnostic Trouble Codes (DTC)". <Ref. to EN(STi)-66, List of Diagnostic Trouble Code (DTC).>  NOTE: In this case, it is not necessary to inspect DTC P0181.	Replace the fuel temperature sensor. <Ref. to EC(STi)-8, Fuel Temperature Sensor.>

# DIAGNOSTIC PROCEDURE WITH DIAGNOSTIC TROUBLE CODE (DTC)

ENGINE (DIAGNOSTICS)

## AH:DTC P0182 — FUEL TEMPERATURE SENSOR “A” CIRCUIT LOW INPUT —

### • DTC DETECTING CONDITION:

- Immediately at fault recognition
- GENERAL DESCRIPTION <Ref. to GD(STi)-80, DTC P0182 — FUEL TEMPERATURE SENSOR “A” CIRCUIT LOW INPUT —, Diagnostic Trouble Code (DTC) Detecting Criteria.>

### CAUTION:

After repair or replacement of faulty parts, conduct Clear Memory Mode <Ref. to EN(STi)-42, OPERATION, Clear Memory Mode.> and Inspection Mode <Ref. to EN(STi)-35, OPERATION, Inspection Mode.>.

### • WIRING DIAGRAM:

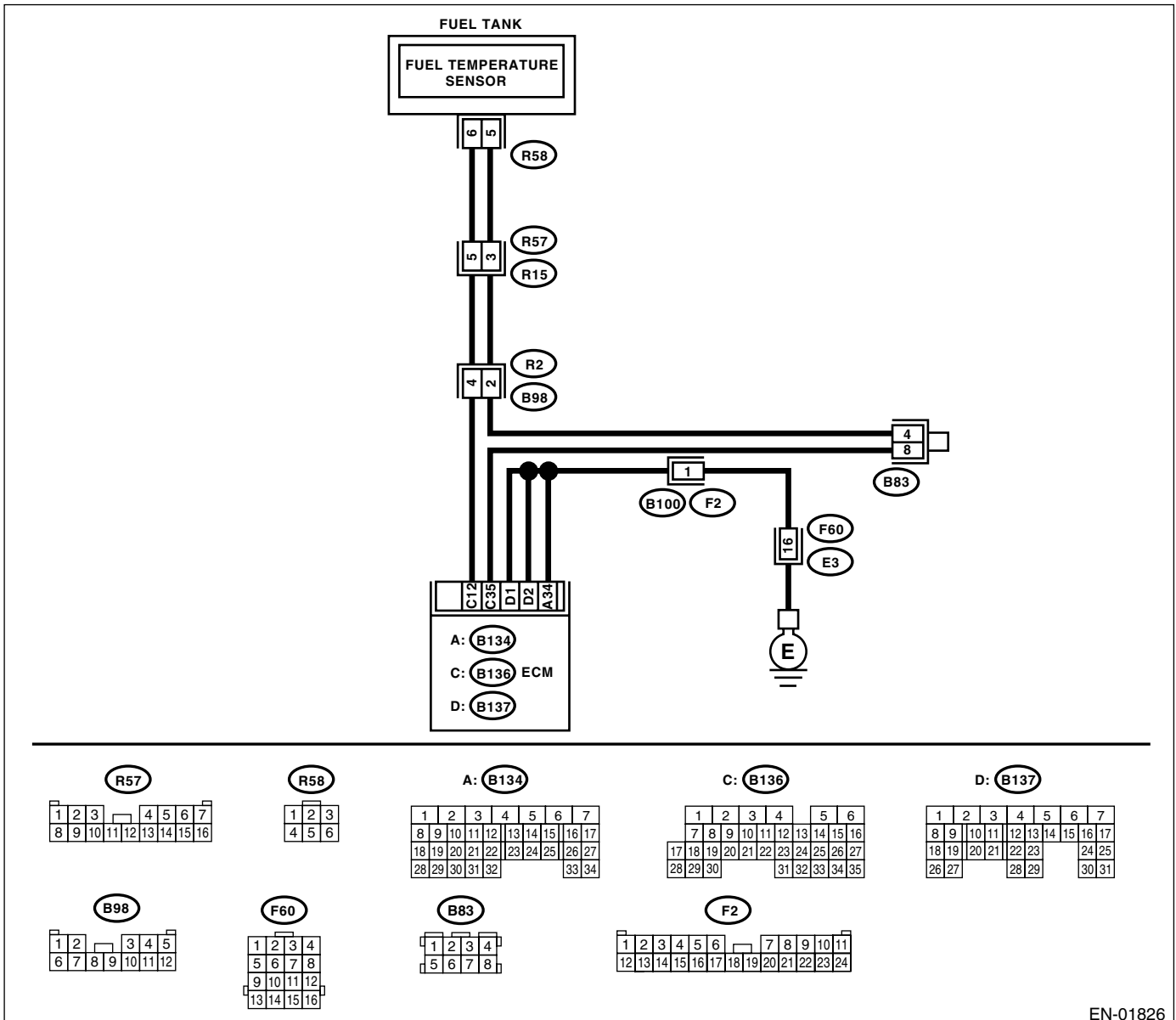

EN-01826



# DIAGNOSTIC PROCEDURE WITH DIAGNOSTIC TROUBLE CODE (DTC)

ENGINE (DIAGNOSTICS)

	Step	Check	Yes	No
<b>1</b> <b>CHECK CURRENT DATA.</b> 1)Start the engine. 2)Read the data of fuel temperature sensor signal using Subaru Select Monitor or OBD-II general scan tool.  NOTE: •Subaru Select Monitor For detailed operation procedures, refer to "READ CURRENT DATA FOR ENGINE". <Ref. to EN(STi)-28, Subaru Select Monitor.> •OBD-II general scan tool For detailed operation procedures, refer to the OBD-II General Scan Tool Instruction Manual.	Is the temperature more than 150°C (302°F)?	Go to step 2.	The malfunction indicator light may light up, however, the circuit is returned to the normal status at the moment.	
<b>2</b> <b>CHECK CURRENT DATA.</b> 1)Turn ignition switch to OFF. 2)Remove the access hole lid. 3)Disconnect the connector from fuel pump. 4)Turn ignition switch to ON. 5)Read the data of fuel temperature sensor signal using Subaru Select Monitor or OBD-II general scan tool.  NOTE: •Subaru Select Monitor For detailed operation procedures, refer to "READ CURRENT DATA FOR ENGINE". <Ref. to EN(STi)-28, Subaru Select Monitor.> •OBD-II general scan tool For detailed operation procedures, refer to the OBD-II General Scan Tool Instruction Manual.	Is the temperature less than -40°C (-40°F)?	Replace the fuel temperature sensor. <Ref. to EC(STi)-8, Fuel Temperature Sensor.>	Repair short circuit to ground in harness between fuel pump and ECM connector.	

# DIAGNOSTIC PROCEDURE WITH DIAGNOSTIC TROUBLE CODE (DTC)

ENGINE (DIAGNOSTICS)

## AI: DTC P0183 — FUEL TEMPERATURE SENSOR “A” CIRCUIT HIGH INPUT —

### • DTC DETECTING CONDITION:

- Immediately at fault recognition
- GENERAL DESCRIPTION <Ref. to GD(STi)-82, DTC P0183 — FUEL TEMPERATURE SENSOR “A” CIRCUIT HIGH INPUT —, Diagnostic Trouble Code (DTC) Detecting Criteria.>

### CAUTION:

After repair or replacement of faulty parts, conduct Clear Memory Mode <Ref. to EN(STi)-42, OPERATION, Clear Memory Mode.> and Inspection Mode <Ref. to EN(STi)-35, OPERATION, Inspection Mode.>.

### • WIRING DIAGRAM:

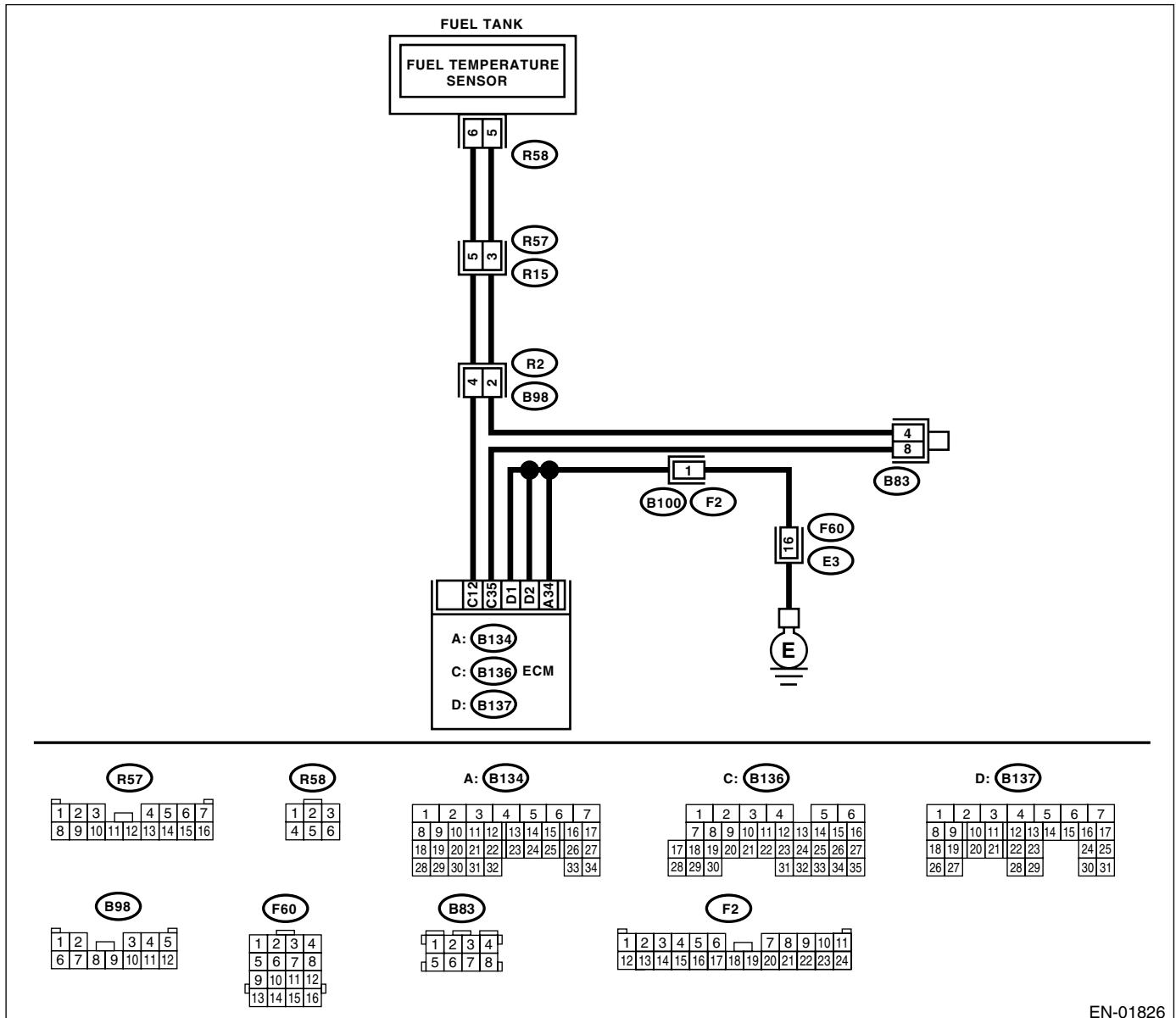

EN-01826

# DIAGNOSTIC PROCEDURE WITH DIAGNOSTIC TROUBLE CODE (DTC)

ENGINE (DIAGNOSTICS)

Step	Check	Yes	No
<p><b>1 CHECK CURRENT DATA.</b>                      1)Start the engine.                      2)Read the data of fuel temperature sensor signal using Subaru Select Monitor or OBD-II general scan tool.</p> <p>NOTE:                      •Subaru Select Monitor                      For detailed operation procedures, refer to "READ CURRENT DATA FOR ENGINE".                      &lt;Ref. to EN(STi)-28, Subaru Select Monitor.&gt;                      •OBD-II general scan tool                      For detailed operation procedures, refer to the OBD-II General Scan Tool Instruction Manual.</p>	<p>Is the temperature less than -40°C (-40°F)?</p>	<p>Go to step 2.</p>	<p>Repair poor contact.</p> <p>NOTE:                      In this case, repair the following:</p> <ul style="list-style-type: none"> <li>• Poor contact in fuel pump connector</li> <li>• Poor contact in ECM connector</li> <li>• Poor contact in coupling connector</li> <li>• Poor contact in joint connector</li> </ul>
<p><b>2 CHECK HARNESS BETWEEN FUEL TEMPERATURE SENSOR AND ECM CONNECTOR.</b>                      1)Turn ignition switch to OFF.                      2)Remove the access hole lid.                      3)Disconnect the connector from fuel pump.                      4)Measure the voltage between fuel pump connector and chassis ground.</p> <p><b>Connector &amp; terminal</b>  <i>(R58) No. 6 (+) — Chassis ground (-):</i></p>	<p>Is the voltage more than 10 V?</p>	<p>Repair short circuit to battery in harness between ECM and fuel pump connector.</p>	<p>Go to step 3.</p>
<p><b>3 CHECK HARNESS BETWEEN FUEL TEMPERATURE SENSOR AND ECM CONNECTOR.</b>                      1)Turn ignition switch to ON.                      2)Measure the voltage between fuel pump connector and chassis ground.</p> <p><b>Connector &amp; terminal</b>  <i>(R58) No. 6 (+) — Chassis ground (-):</i></p>	<p>Is the voltage more than 10 V?</p>	<p>Repair short circuit to battery in harness between ECM and fuel pump connector.</p>	<p>Go to step 4.</p>
<p><b>4 CHECK HARNESS BETWEEN FUEL TEMPERATURE SENSOR AND ECM CONNECTOR.</b>                      Measure the voltage between fuel pump connector and chassis ground.</p> <p><b>Connector &amp; terminal</b>  <i>(R58) No. 6 (+) — Chassis ground (-):</i></p>	<p>Is the voltage more than 4 V?</p>	<p>Go to step 5.</p>	<p>Repair harness and connector.</p> <p>NOTE:                      In this case, repair the following:</p> <ul style="list-style-type: none"> <li>• Open circuit in harness between ECM and fuel pump connector</li> <li>• Poor contact in fuel pump connector</li> <li>• Poor contact in ECM connector</li> <li>• Poor contact in coupling connector</li> </ul>

# DIAGNOSTIC PROCEDURE WITH DIAGNOSTIC TROUBLE CODE (DTC)

ENGINE (DIAGNOSTICS)

Step	Check	Yes	No
<p>5</p> <p><b>CHECK HARNESS BETWEEN FUEL TEMPERATURE SENSOR AND ECM CONNECTOR.</b></p> <p>1) Turn ignition switch to OFF. 2) Disconnect the connector from ECM. 3) Measure the resistance of harness between fuel pump connector and ECM.</p> <p><b>Connector &amp; terminal</b> <b>(R58) No. 5 — (B136) No. 35:</b></p>	<p>Is the resistance less than 1 <math>\Omega</math>?</p>	<p>Replace the fuel temperature sensor. &lt;Ref. to EC(STi)-8, Fuel Temperature Sensor.&gt;</p>	<p>Repair harness and connector.</p> <p>NOTE: In this case, repair the following:</p> <ul style="list-style-type: none"><li>• Open circuit in harness between ECM and fuel pump connector</li><li>• Poor contact in fuel pump connector</li><li>• Poor contact in ECM connector</li><li>• Poor contact in coupling connector</li><li>• Poor contact in joint connector</li></ul>

## DIAGNOSTIC PROCEDURE WITH DIAGNOSTIC TROUBLE CODE (DTC)

ENGINE (DIAGNOSTICS)

### AJ:DTC P0222 — THROTTLE/PEDAL POSITION SENSOR/SWITCH “B” CIRCUIT LOW INPUT —

- **DTC DETECTING CONDITION:**

- Immediately at fault recognition
- GENERAL DESCRIPTION <Ref. to GD(STi)-84, DTC P0222 — THROTTLE/PEDAL POSITION SENSOR/SWITCH “B” CIRCUIT LOW INPUT —, Diagnostic Trouble Code (DTC) Detecting Criteria.>

- **TROUBLE SYMPTOM:**

- Erroneous idling
- Poor driving performance
- Engine stalls.

# DIAGNOSTIC PROCEDURE WITH DIAGNOSTIC TROUBLE CODE (DTC)

## ENGINE (DIAGNOSTICS)

### • WIRING DIAGRAM:

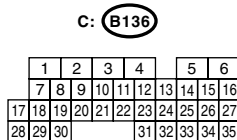
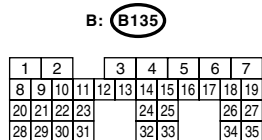
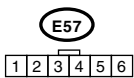
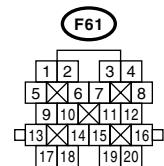
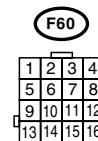
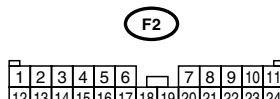
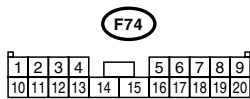
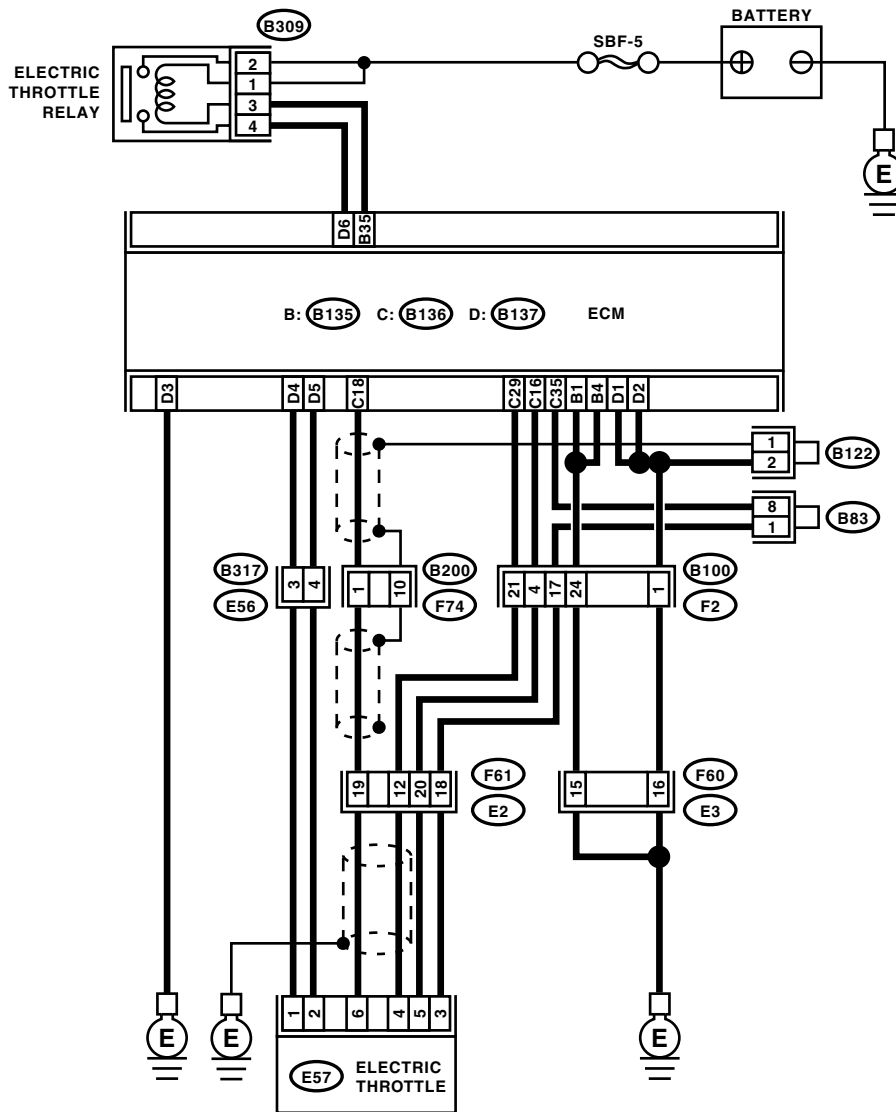

EN-01825

# DIAGNOSTIC PROCEDURE WITH DIAGNOSTIC TROUBLE CODE (DTC)

ENGINE (DIAGNOSTICS)

Step	Check	Yes	No
<b>1</b> <b>CHECK OUTPUT VOLTAGE OF SENSOR.</b> 1) Turn the ignition switch to ON. 2) Measure the voltage between ECM connector terminals. <i>Connector &amp; terminal</i> <i>(B136) No. 29 (+) — (B136) No. 35 (-):</i> 3) Shake the ECM harness and connector, engine harness connectors (E84, E22), electric throttle connector harness while monitoring value of voltage meter.	Is the voltage more than 0.8 V?	Go to step 2.	Go to step 3.
<b>2</b> <b>CHECK POOR CONTACT IN CONNECTORS.</b> Check poor contact in the connectors between the ECM and electric throttle.	Is there poor contact in the connectors between ECM and electric throttle?	Repair the poor contact in connectors.	Connector has returned to a normal condition at this time. A temporary poor contact of the connector may be the cause.
<b>3</b> <b>CHECK HARNESS BETWEEN ECM AND ELECTRIC THROTTLE.</b> 1) Turn the ignition switch to OFF. 2) Disconnect the connector from ECM. 3) Disconnect the connector from electric throttle. 4) Measure the resistance between the ECM connector and electric throttle connector. <i>Connector &amp; terminal</i> <i>(B136) No. 16 — (E57) No. 5:</i>	Is the resistance less than 1 $\Omega$ ?	Go to step 4.	Repair the open harness connector.
<b>4</b> <b>CHECK HARNESS BETWEEN ECM AND ELECTRIC THROTTLE.</b> Check the resistance between the ECM connector and chassis ground. <i>Connector &amp; terminal</i> <i>(B136) No. 29 — Chassis ground:</i> <i>(B136) No. 16 — Chassis ground:</i>	Is the resistance more than 1 M $\Omega$ ?	Go to step 5.	Repair the chassis short of harness.
<b>5</b> <b>CHECK POWER SUPPLY TO SENSOR.</b> 1) Connect the ECM connectors. 2) Turn the ignition switch to ON. 3) Measure the voltage between electric throttle connector and engine ground. <i>Connector &amp; terminal</i> <i>(E57) No. 5 (+) — Engine ground (-):</i> 4) Shake the ECM harness and connector, engine harness connectors, while monitoring value of voltage meter.	Is the voltage 4.5 — 5.5 V?	Go to step 6.	Repair the poor contact in ECM connector. If problem persists, replace the ECM. <Ref. to FU(STi)-41, Engine Control Module (ECM).>
<b>6</b> <b>CHECK SHORT OF ECM.</b> 1) Turn the ignition switch to OFF. 2) Measure the resistance between electric throttle connector and engine ground. <i>Connector &amp; terminal</i> <i>(E57) No. 4 — Engine ground:</i>	Is the resistance more than 10 $\Omega$ ?	Repair the poor contact in electric throttle connector. If problem persists, replace the electric throttle.	Repair the poor contact in ECM connectors. If problem persists, replace the ECM. <Ref. to FU(STi)-41, Engine Control Module (ECM).>

## DIAGNOSTIC PROCEDURE WITH DIAGNOSTIC TROUBLE CODE (DTC)

ENGINE (DIAGNOSTICS)

---

### AK:DTC P0223 — THROTTLE/PEDAL POSITION SENSOR/SWITCH “B” CIRCUIT HIGH INPUT —

• **DTC DETECTING CONDITION:**

- Immediately at fault recognition
- GENERAL DESCRIPTION <Ref. to GD(STi)-86, DTC P0223 — THROTTLE/PEDAL POSITION SENSOR/SWITCH “B” CIRCUIT HIGH INPUT —, Diagnostic Trouble Code (DTC) Detecting Criteria.>

• **TROUBLE SYMPTOM:**

- Erroneous idling
- Poor driving performance
- Engine stalls.



# DIAGNOSTIC PROCEDURE WITH DIAGNOSTIC TROUBLE CODE (DTC) ENGINE (DIAGNOSTICS)

• WIRING DIAGRAM:

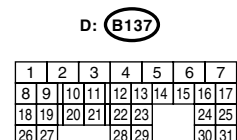
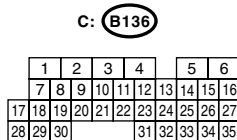
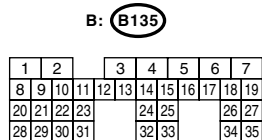
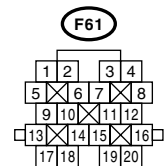
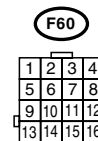
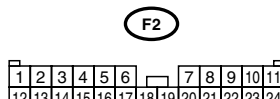
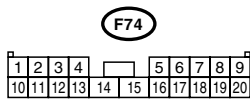
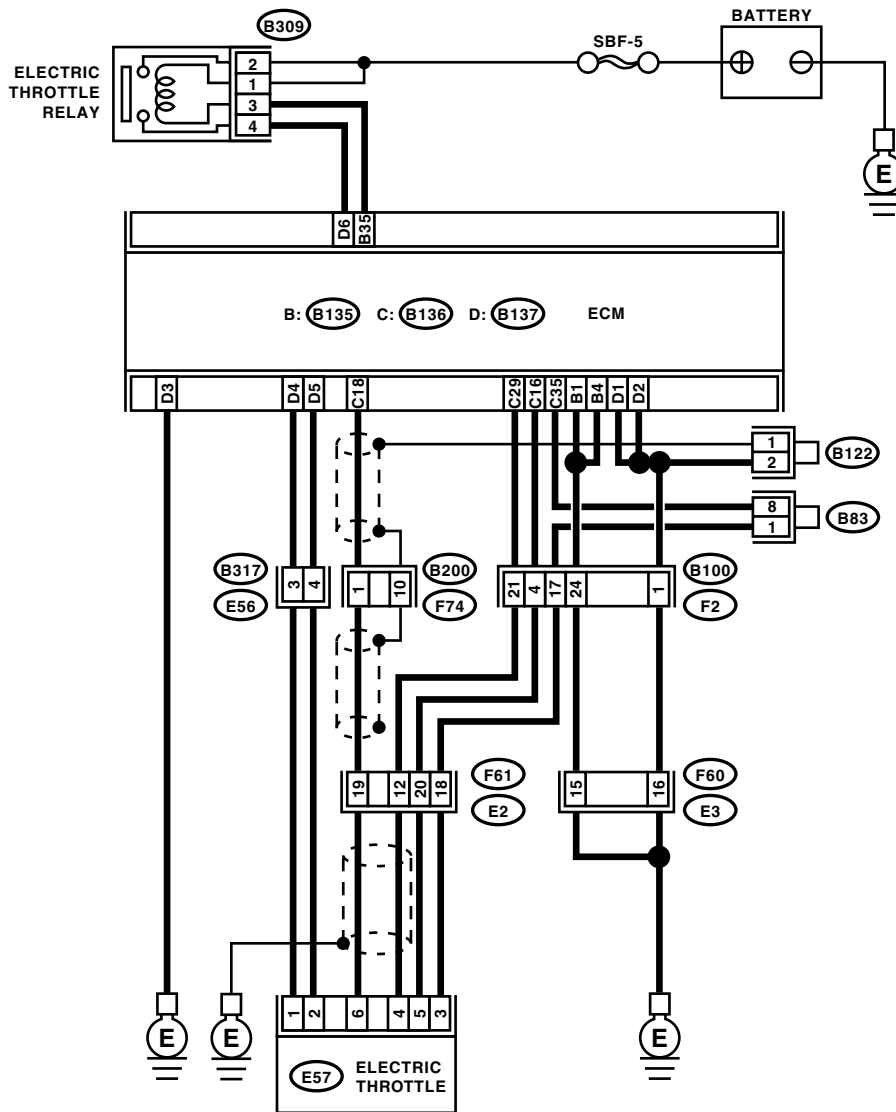

EN-01825

# DIAGNOSTIC PROCEDURE WITH DIAGNOSTIC TROUBLE CODE (DTC)

ENGINE (DIAGNOSTICS)

Step	Check	Yes	No
<b>1 CHECK OUTPUT VOLTAGE OF SENSOR.</b> 1) Turn the ignition switch to ON. 2) Read the data of sub throttle sensor signals, using the Subaru Select Monitor. 3) Shake the ECM harness and connector, engine harness connectors (E84, E22), electric throttle connector harness while monitoring value of voltage meter.	Is the voltage less than 4.73 V?	Go to step 2.	Go to step 3.
<b>2 CHECK POOR CONTACT IN CONNECTORS.</b> Check poor contact in connectors between ECM and electric throttle.	Is there poor contact in the connectors between ECM and electric throttle?	Repair the poor contact in connectors.	Connector has returned to a normal condition at this time. A temporary poor contact of the connector may be the cause.
<b>3 CHECK HARNESS BETWEEN ECM AND ELECTRIC THROTTLE.</b> 1) Turn the ignition switch to OFF. 2) Disconnect the connectors from ECM. 3) Disconnect the connectors from electric throttle. 4) Measure the resistance between ECM connector and electric throttle connector. <i>Connector &amp; terminal</i> <i>(B136) No. 35 — (E57) No. 3:</i> <i>(B136) No. 29 — (E57) No. 4:</i>	Is the resistance less than 1 $\Omega$ ?	Go to step 4.	Repair the open circuit of harness connector.
<b>4 CHECK HARNESS BETWEEN ECM AND ELECTRIC THROTTLE.</b> 1) Connect the ECM connector. 2) Measure the resistance between the electric throttle connector and engine ground. <i>Connector &amp; terminal</i> <i>(E57) No. 3 — Engine ground:</i>	Is the resistance less than 5 $\Omega$ ?	Go to step 5.	Repair the poor contact in ECM connector. If the problem persists, replace the ECM. <Ref. to FU(STi)-41, Engine Control Module (ECM).>
<b>5 CHECK HARNESS BETWEEN ECM AND ELECTRIC THROTTLE.</b> 1) Connect the ECM connector. 2) Turn the ignition switch to ON. 3) Measure the voltage between electric throttle connector and engine ground. <i>Connector &amp; terminal</i> <i>(E57) No. 5 — Engine ground:</i> 4) Shake the ECM harness and connector, engine harness connectors, while monitoring value of voltage meter.	Is the voltage more than 10 V?	Go to step 6.	Repair the battery short of harness between ECM connector and electric throttle connector.
<b>6 CHECK HARNESS BETWEEN ECM AND ELECTRIC THROTTLE.</b> 1) Measure the voltage between the electric throttle connector and engine ground. <i>Connector &amp; terminal</i> <i>(E57) No. 4 (+) — Engine ground (-):</i> 2) Shake the ECM harness and connector, engine harness connectors, while monitoring value of voltage meter.	Is the voltage less than 10 V?	Go to step 7.	Repair the short of harness between ECM connector and electric throttle connector.

# DIAGNOSTIC PROCEDURE WITH DIAGNOSTIC TROUBLE CODE (DTC)

ENGINE (DIAGNOSTICS)

	Step	Check	Yes	No
7	<b>CHECK HARNESS BETWEEN ECM AND ELECTRIC THROTTLE.</b> 1) Turn the ignition switch to OFF. 2) Disconnect the connector from ECM. 3) Measure the voltage between connectors. <b>Connector &amp; terminal</b> <b>(B136) No. 29 — (B136) No. 16:</b>	Is the resistance more than 1 MΩ?	Repair the poor contact in electric throttle connector. If problem persists, replace the electric throttle.	Short circuit of sensor power supply may be the cause.

# DIAGNOSTIC PROCEDURE WITH DIAGNOSTIC TROUBLE CODE (DTC)

ENGINE (DIAGNOSTICS)

## AL:DTC P0230 — FUEL PUMP PRIMARY CIRCUIT —

### • DTC DETECTING CONDITION:

- Immediately at fault recognition
- GENERAL DESCRIPTION <Ref. to GD(STi)-88, DTC P0230 — FUEL PUMP PRIMARY CIRCUIT —, Diagnostic Trouble Code (DTC) Detecting Criteria.>

### CAUTION:

After repair or replacement of faulty parts, conduct Clear Memory Mode <Ref. to EN(STi)-42, OPERATION, Clear Memory Mode.> and Inspection Mode <Ref. to EN(STi)-35, OPERATION, Inspection Mode.>.

### • WIRING DIAGRAM:

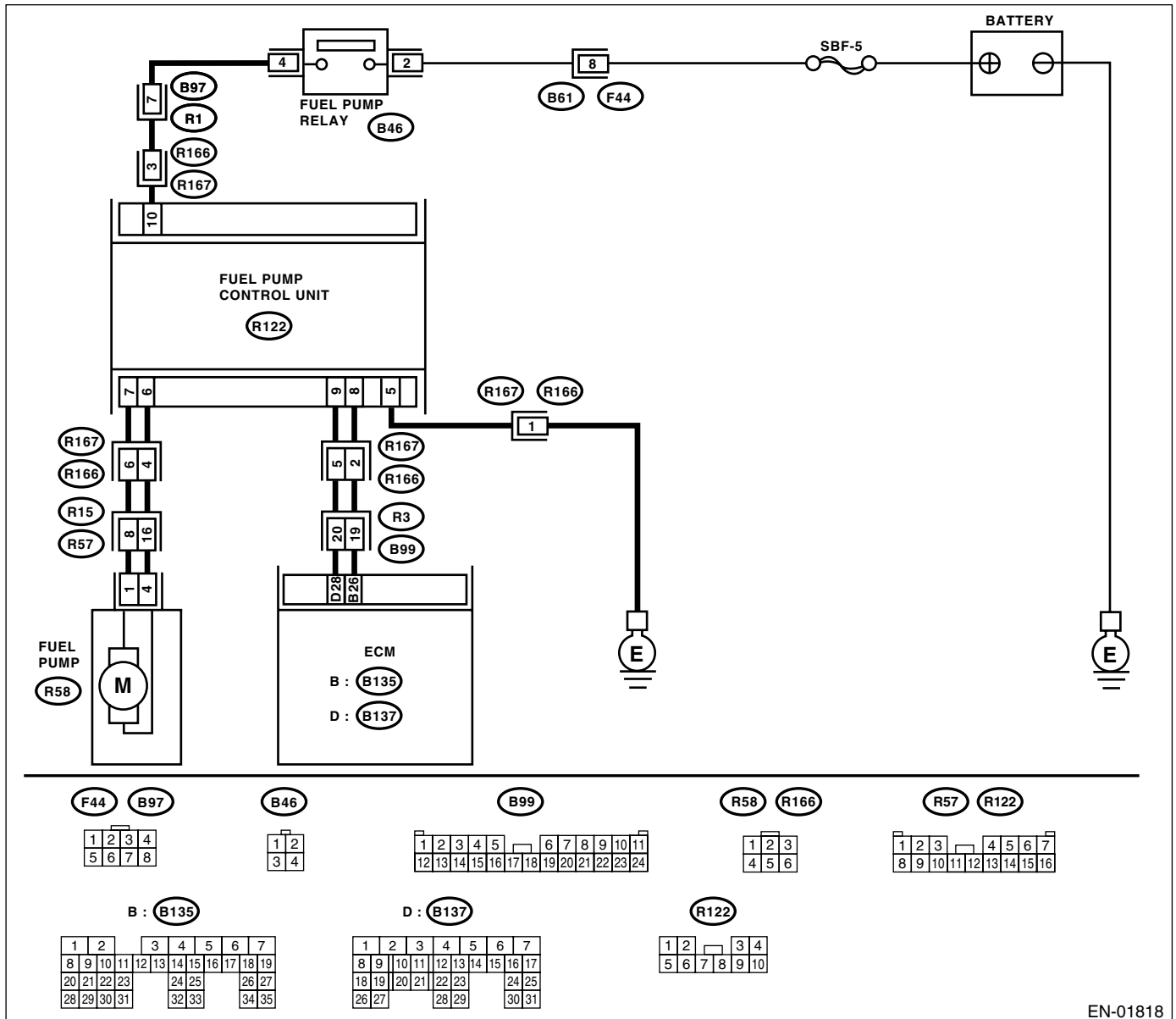

EN-01818

# DIAGNOSTIC PROCEDURE WITH DIAGNOSTIC TROUBLE CODE (DTC)

ENGINE (DIAGNOSTICS)

	Step	Check	Yes	No
1	<p><b>CHECK POWER SUPPLY CIRCUIT TO FUEL PUMP CONTROL UNIT.</b></p> <p>1) Turn the ignition switch to OFF.                      2) Disconnect the connector from fuel pump control unit.                      3) Turn the ignition switch to ON.                      4) Measure the voltage between fuel pump control unit and chassis ground.</p> <p><b>Connector &amp; terminal</b>                      (R122) No. 10 (+) — Chassis ground (-):</p>	Is the voltage more than 10 V?	Go to step 2.	<p>Repair the power supply circuit.</p> <p><b>NOTE:</b>                      In this case repair the following:</p> <ul style="list-style-type: none"> <li>• Open or ground short circuit in harness between fuel pump relay and fuel pump control unit</li> <li>• Poor contact in fuel pump control unit connector</li> <li>• Poor contact in fuel pump relay connector</li> </ul>
2	<p><b>CHECK GROUND CIRCUIT OF FUEL PUMP CONTROL UNIT.</b></p> <p>1) Turn the ignition switch to OFF.                      2) Measure the resistance of harness between fuel pump control unit and chassis ground.</p> <p><b>Connector &amp; terminal</b>                      (R122) No. 5 — Chassis ground:</p>	Is the resistance less than 5 Ω?	Go to step 3.	<p>Repair the harness and connector.</p> <p><b>NOTE:</b>                      In this case, repair the following:</p> <ul style="list-style-type: none"> <li>• Open circuit between fuel pump control unit and chassis ground</li> <li>• Poor contact in fuel pump control unit connector</li> </ul>
3	<p><b>CHECK HARNESS BETWEEN FUEL PUMP CONTROL UNIT AND FUEL PUMP CONNECTOR.</b></p> <p>1) Disconnect the connector from fuel pump.                      2) Measure the resistance of harness between fuel pump control unit and fuel pump connector.</p> <p><b>Connector &amp; terminal</b>                      (R122) No. 7 — (R58) No. 1:                      (R122) No. 6 — (R58) No. 4:</p>	Is the resistance less than 1 Ω?	Go to step 4.	Repair the open circuit between fuel pump control unit and fuel pump.
4	<p><b>CHECK HARNESS BETWEEN FUEL PUMP CONTROL UNIT AND FUEL PUMP CONNECTOR.</b></p> <p>Measure the resistance of harness between fuel pump control unit and chassis ground.</p> <p><b>Connector &amp; terminal</b>                      (R122) No. 7 — Chassis ground:                      (R122) No. 6 — Chassis ground:</p>	Is the resistance more than 1 MΩ?	Go to step 5.	Repair the ground short circuit between fuel pump control unit and fuel pump.

# DIAGNOSTIC PROCEDURE WITH DIAGNOSTIC TROUBLE CODE (DTC)

ENGINE (DIAGNOSTICS)

Step	Check	Yes	No
<p><b>5 CHECK HARNESS BETWEEN FUEL PUMP CONTROL UNIT AND ECM CONNECTOR.</b>                      1) Turn the ignition switch to OFF.                      2) Disconnect the connector from ECM.                      3) Measure the resistance of harness between fuel pump control unit and ECM connector.  <b>Connector &amp; terminal</b>                      (R122) No. 9 — (B137) No. 28:                      (R122) No. 8 — (B135) No. 26:</p>	<p>Is the resistance less than 1 <math>\Omega</math>?</p>	<p>Go to step 6.</p>	<p>Repair the harness and connector.                      NOTE:                      In this case, repair the following:                      • Open circuit between fuel pump control unit and ECM                      • Poor contact in fuel pump control unit and ECM connector</p>
<p><b>6 CHECK HARNESS BETWEEN FUEL PUMP CONTROL UNIT AND ECM CONNECTOR.</b>                      Measure the resistance of harness between fuel pump control unit and chassis ground.  <b>Connector &amp; terminal</b>                      (R122) No. 9 — Chassis ground:                      (R122) No. 8 — Chassis ground:</p>	<p>Is the resistance more than 1 M<math>\Omega</math>?</p>	<p>Go to step 7.</p>	<p>Repair the ground short circuit between fuel pump control unit and ECM.</p>
<p><b>7 CHECK POOR CONTACT.</b>                      Check poor contact in ECM and fuel pump control unit connector.</p>	<p>Is there poor contact in ECM and fuel pump control unit connector?</p>	<p>Repair the poor contact in ECM and fuel pump control unit.</p>	<p>Go to step 8.</p>
<p><b>8 CHECK EXPERIENCE OF OUT OF GAS.</b></p>	<p>Have the vehicle been out of gas before?</p>	<p>Complete the diagnosis.                      NOTE:                      DTC may be recorded due to the idle running of fuel pump at out of gas.</p>	<p>Replace the fuel pump control unit.                      &lt;Ref. to FU(STi)-44, Fuel Pump Control Unit.&gt;</p>

# DIAGNOSTIC PROCEDURE WITH DIAGNOSTIC TROUBLE CODE (DTC)

ENGINE (DIAGNOSTICS)

## AM:DTC P0244 — TURBO/SUPER CHARGER WASTEGATE SOLENOID “A” RANGE/PERFORMANCE —

### • DTC DETECTING CONDITION:

- Immediately at fault recognition
- GENERAL DESCRIPTION <Ref. to GD(STi)-90, DTC P0244 — TURBO/SUPER CHARGER WASTEGATE SOLENOID “A” RANGE/PERFORMANCE —, Diagnostic Trouble Code (DTC) Detecting Criteria.>

### • TROUBLE SYMPTOM:

- Erroneous idling
- Engine stalls.
- Poor driving performance

### CAUTION:

After repair or replacement of faulty parts, conduct Clear Memory Mode <Ref. to EN(STi)-42, OPERATION, Clear Memory Mode.> and Inspection Mode <Ref. to EN(STi)-35, OPERATION, Inspection Mode.>.

### • WIRING DIAGRAM:

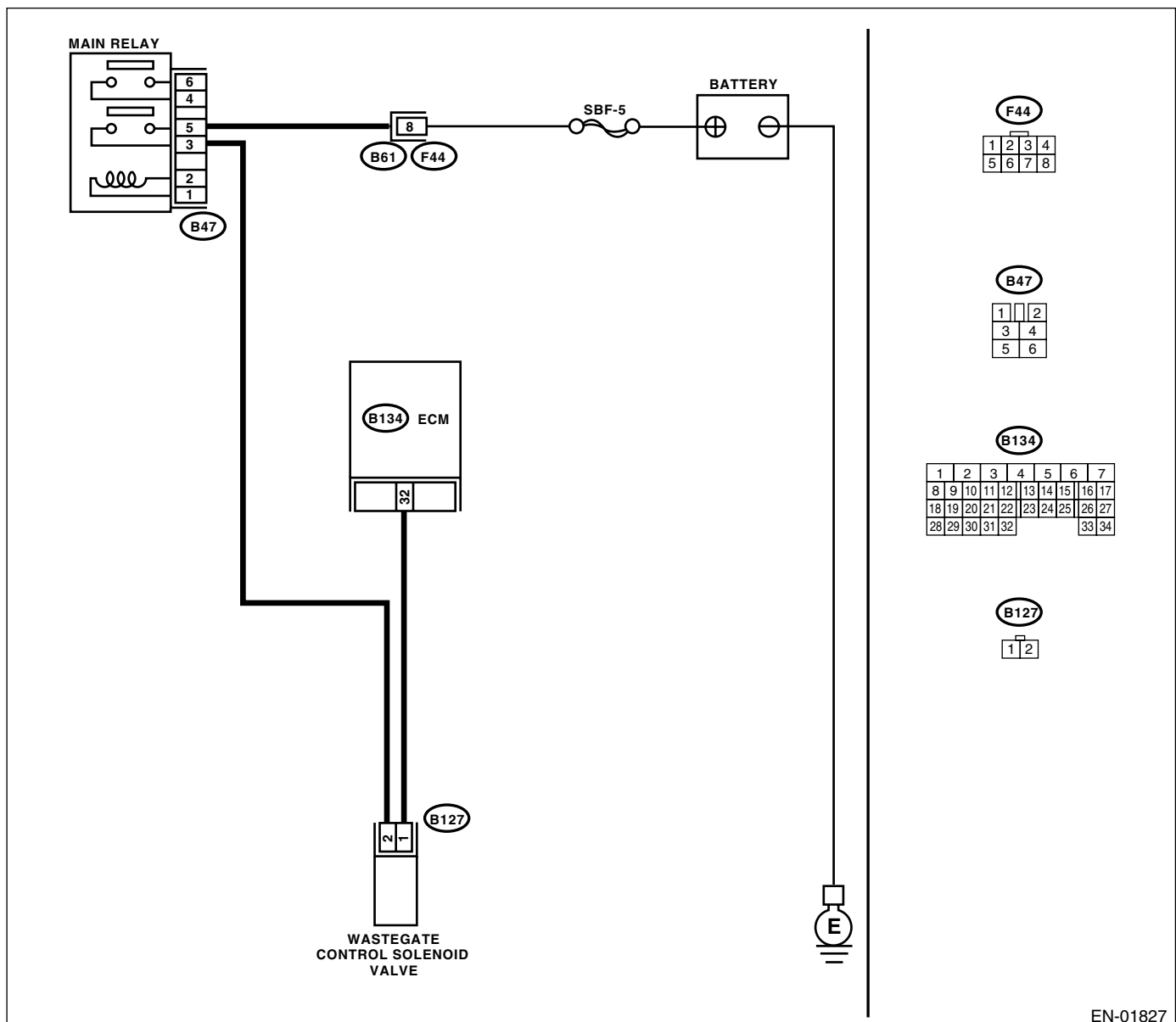

EN-01827

# DIAGNOSTIC PROCEDURE WITH DIAGNOSTIC TROUBLE CODE (DTC)

ENGINE (DIAGNOSTICS)

	Step	Check	Yes	No
1	<b>CHECK ANY OTHER DTC ON DISPLAY.</b>	Is any other DTC displayed?	Inspect the relevant DTC using "List of Diagnostic Trouble Code (DTC)". <Ref. to EN(STi)-66, List of Diagnostic Trouble Code (DTC).>  NOTE: In this case, it is not necessary to inspect DTC P0244.	Replace the wastegate control solenoid valve. <Ref. to FU(STi)-36, Wastegate Control Solenoid Valve.>



# DIAGNOSTIC PROCEDURE WITH DIAGNOSTIC TROUBLE CODE (DTC)

ENGINE (DIAGNOSTICS)

## AN:DTC P0245 — TURBO/SUPER CHARGER WASTEGATE SOLENOID “A” LOW —

### • DTC DETECTING CONDITION:

- Immediately at fault recognition
- GENERAL DESCRIPTION <Ref. to GD(STi)-92, DTC P0245 — TURBO/SUPER CHARGER WASTEGATE SOLENOID “A” LOW —, Diagnostic Trouble Code (DTC) Detecting Criteria.>

### • TROUBLE SYMPTOM:

- Erroneous idling

### CAUTION:

After repair or replacement of faulty parts, conduct Clear Memory Mode <Ref. to EN(STi)-42, OPERATION, Clear Memory Mode.> and Inspection Mode <Ref. to EN(STi)-35, OPERATION, Inspection Mode.>.

### • WIRING DIAGRAM:

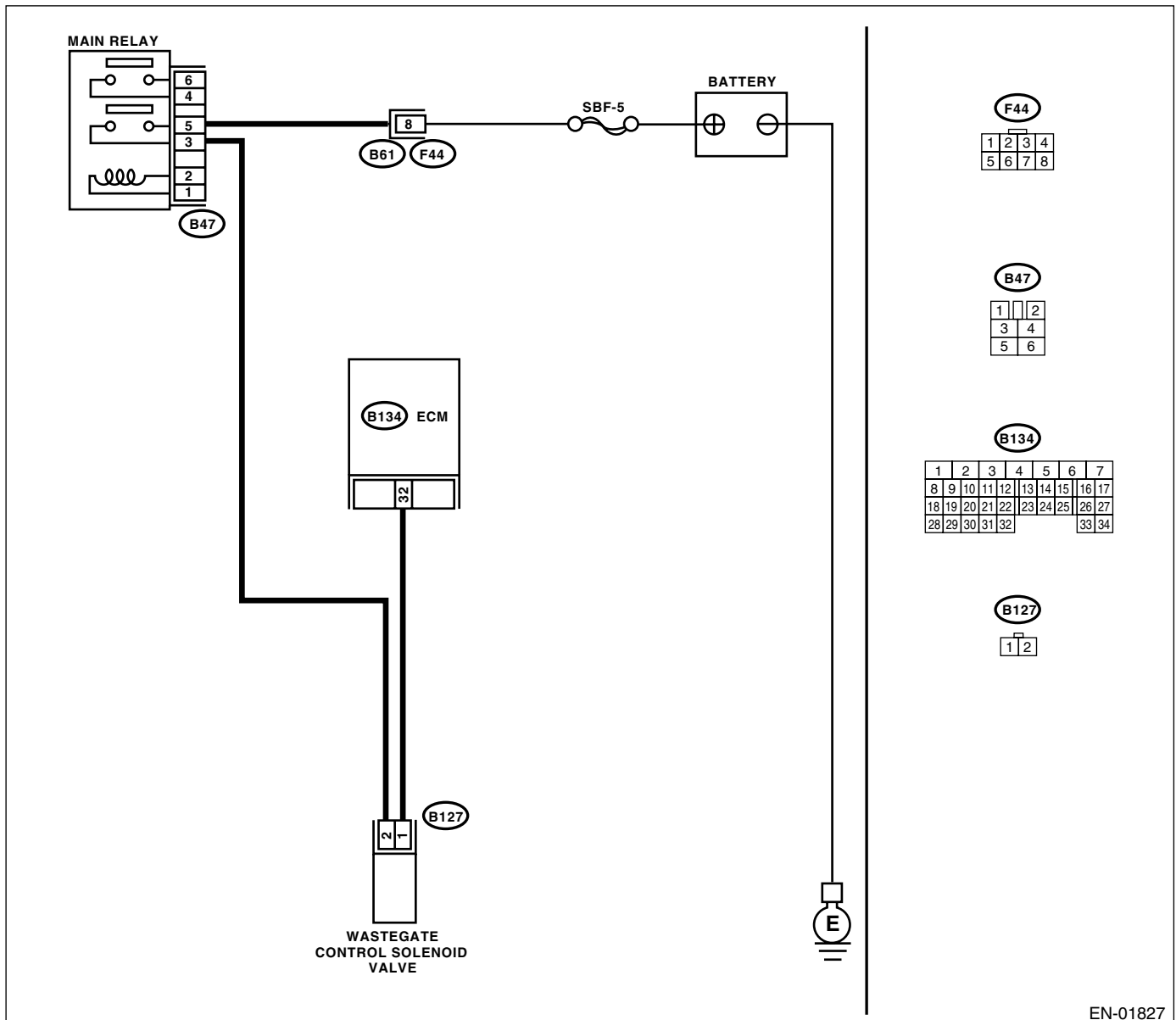

EN-01827

# DIAGNOSTIC PROCEDURE WITH DIAGNOSTIC TROUBLE CODE (DTC)

## ENGINE (DIAGNOSTICS)

	Step	Check	Yes	No
1	<b>CHECK OUTPUT SIGNAL FROM ECM.</b> 1) Turn the ignition switch to ON. 2) Measure the voltage between ECM and chassis ground. <b>Connector &amp; terminal</b> <b>(B134) No. 32 (+) — Chassis ground (-):</b>	Is the voltage more than 10 V?	Even if malfunction indicator light lights up, the circuit has returned to a normal condition at this time.	Go to step 2.
2	<b>CHECK HARNESS BETWEEN WASTEGATE CONTROL SOLENOID VALVE AND ECM CONNECTOR.</b> 1) Turn the ignition switch to OFF. 2) Disconnect the connectors from wastegate control solenoid valve and ECM. 3) Measure the resistance of harness between wastegate control solenoid valve connector and engine ground. <b>Connector &amp; terminal</b> <b>(B127) No. 1 — Engine ground:</b>	Is the resistance less than 10 $\Omega$ ?	Repair the ground short circuit in harness between ECM and wastegate control solenoid valve connector.	Go to step 3.
3	<b>CHECK HARNESS BETWEEN WASTEGATE CONTROL SOLENOID VALVE AND ECM CONNECTOR.</b> Measure the resistance of harness between ECM and wastegate control solenoid valve of harness connector. <b>Connector &amp; terminal</b> <b>(B134) No. 32 — (B127) No. 1:</b>	Is the resistance less than 1 $\Omega$ ?	Go to step 4.	Repair the open circuit in harness between ECM and wastegate control solenoid valve connector.  NOTE: In this case, repair the following: • Open circuit in harness between ECM and wastegate control solenoid valve connector
4	<b>CHECK WASTEGATE CONTROL SOLENOID VALVE.</b> 1) Remove the wastegate control solenoid valve. 2) Measure the resistance between wastegate control solenoid valve terminals. <b>Terminals</b> <b>No. 1 — No. 2:</b>	Is the resistance 30 — 40 $\Omega$ ?	Go to step 5.	Replace the wastegate control solenoid valve. <Ref. to FU(STi)-36, Wastegate Control Solenoid Valve.>
5	<b>CHECK POWER SUPPLY TO WASTEGATE CONTROL SOLENOID VALVE.</b> 1) Turn the ignition switch to ON. 2) Measure the voltage between wastegate control solenoid valve and engine ground. <b>Connector &amp; terminal</b> <b>(B127) No. 2 (+) — Engine ground (-):</b>	Is the voltage more than 10 V?	Go to step 6.	Repair the open circuit in harness between main relay and wastegate control solenoid valve connector.
6	<b>CHECK POOR CONTACT.</b> Check poor contact in wastegate control solenoid valve connector.	Is there poor contact in wastegate control solenoid valve connector?	Repair the poor contact in wastegate control solenoid valve connector.	Contact your SOA Service Center.  NOTE: Inspection by DTM is required, because probable cause is deterioration of multiple parts.

# DIAGNOSTIC PROCEDURE WITH DIAGNOSTIC TROUBLE CODE (DTC)

ENGINE (DIAGNOSTICS)

## AO:DTC P0246 — TURBO/SUPER CHARGER WASTEGATE SOLENOID “A” HIGH —

### • DTC DETECTING CONDITION:

- Immediately at fault recognition
- GENERAL DESCRIPTION <Ref. to GD(STi)-94, DTC P0246 — TURBO/SUPER CHARGER WASTEGATE SOLENOID “A” HIGH —, Diagnostic Trouble Code (DTC) Detecting Criteria.>

### • TROUBLE SYMPTOM:

- Erroneous idling

### CAUTION:

After repair or replacement of faulty parts, conduct Clear Memory Mode <Ref. to EN(STi)-42, OPERATION, Clear Memory Mode.> and Inspection Mode <Ref. to EN(STi)-35, OPERATION, Inspection Mode.>.

### • WIRING DIAGRAM:

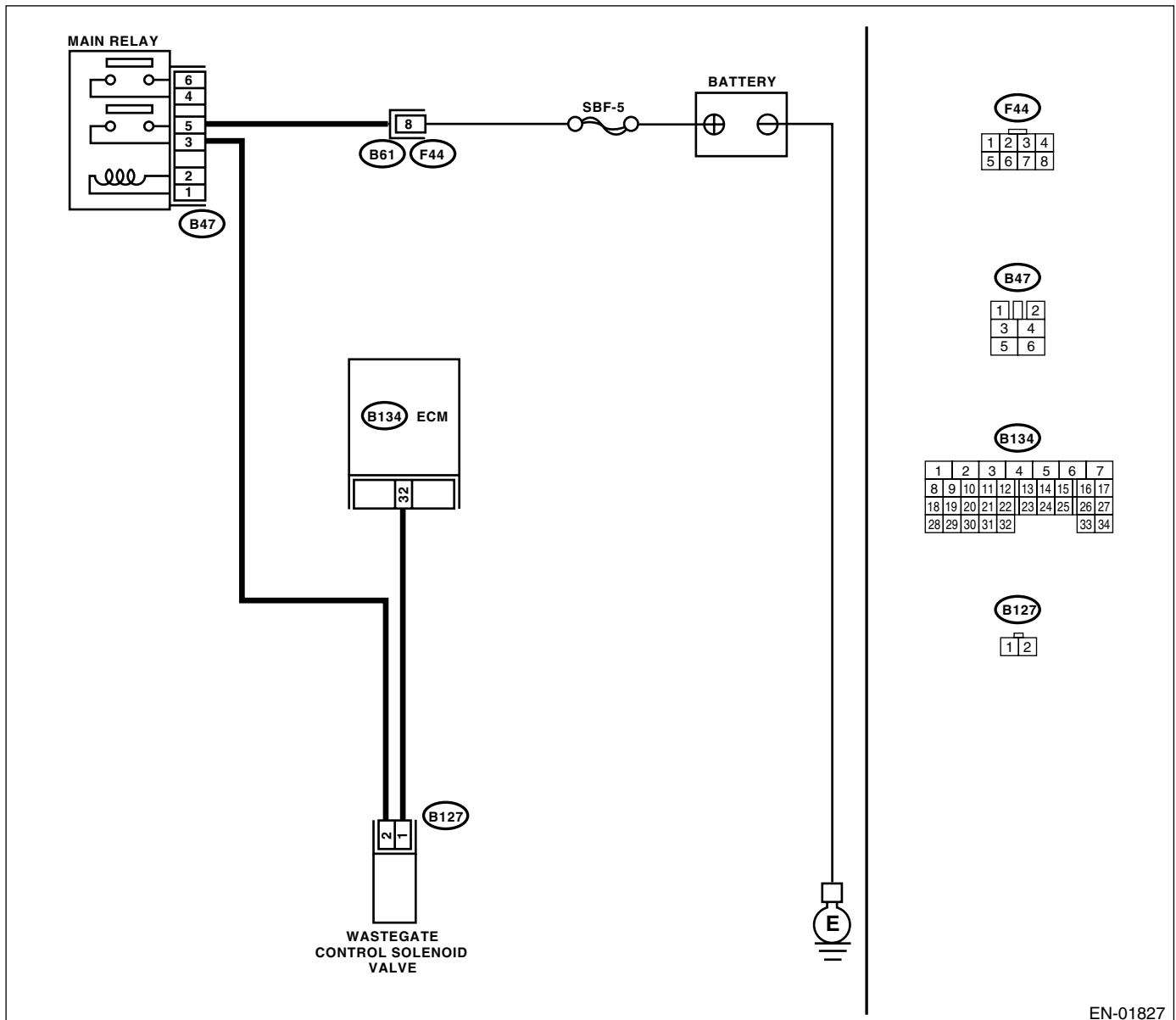

EN-01827

# DIAGNOSTIC PROCEDURE WITH DIAGNOSTIC TROUBLE CODE (DTC)

ENGINE (DIAGNOSTICS)

Step	Check	Yes	No
<b>1 CHECK OUTPUT SIGNAL FROM ECM.</b> 1) Turn the ignition switch to ON. 2) Measure the voltage between ECM and chassis ground. <i>Connector &amp; terminal</i> <i>(B134) No. 32 (+) — Chassis ground (-):</i>	Is the voltage more than 10 V?	Go to step 3.	Go to step 2.
<b>2 CHECK POOR CONTACT.</b> Check poor contact in ECM connector.	Is there poor contact in ECM connector?	Repair the poor contact in ECM connector.	Replace the ECM. <Ref. to FU(STi)-41, Engine Control Module (ECM).>
<b>3 CHECK HARNESS BETWEEN WASTEGATE CONTROL SOLENOID VALVE AND ECM CONNECTOR.</b> 1) Turn the ignition switch to OFF. 2) Disconnect the connector from wastegate control solenoid valve. 3) Turn the ignition switch to ON. 4) Measure the voltage between ECM and chassis ground. <i>Connector &amp; terminal</i> <i>(B134) No. 32 (+) — Chassis ground (-):</i>	Is the voltage more than 10 V?	Repair the battery short circuit in harness between ECM and wastegate control solenoid valve connector. After repair, replace the ECM. <Ref. to FU(STi)-41, Engine Control Module (ECM).>	Go to step 4.
<b>4 CHECK WASTEGATE CONTROL SOLENOID VALVE.</b> 1) Turn the ignition switch to OFF. 2) Measure the resistance between wastegate control solenoid valve terminals. <i>Terminals</i> <i>No. 1 — No. 2:</i>	Is the resistance less than 1 $\Omega$ ?	Replace the wastegate control solenoid valve <Ref. to FU(STi)-36, Wastegate Control Solenoid Valve.> and ECM <Ref. to FU(STi)-41, Engine Control Module (ECM).>	Go to step 5.
<b>5 CHECK POOR CONTACT.</b> Check poor contact in ECM connector.	Is there poor contact in ECM connector?	Repair the poor contact in ECM connector.	Replace the ECM. <Ref. to FU(STi)-41, Engine Control Module (ECM).>

## AP:DTC P0301 — CYLINDER 1 MISFIRE DETECTED —

NOTE:

For the diagnostic procedure, refer to DTC P0304. <Ref. to EN(STi)-165, DTC P0304 — CYLINDER 4 MISFIRE DETECTED —, Diagnostic Procedure with Diagnostic Trouble Code (DTC).>

## AQ:DTC P0302 — CYLINDER 2 MISFIRE DETECTED —

NOTE:

For the diagnostic procedure, refer to DTC P0304. <Ref. to EN(STi)-165, DTC P0304 — CYLINDER 4 MISFIRE DETECTED —, Diagnostic Procedure with Diagnostic Trouble Code (DTC).>

## AR:DTC P0303 — CYLINDER 3 MISFIRE DETECTED —

NOTE:

For the diagnostic procedure, refer to DTC P0304. <Ref. to EN(STi)-165, DTC P0304 — CYLINDER 4 MISFIRE DETECTED —, Diagnostic Procedure with Diagnostic Trouble Code (DTC).>

## DIAGNOSTIC PROCEDURE WITH DIAGNOSTIC TROUBLE CODE (DTC)

ENGINE (DIAGNOSTICS)

### AS:DTC P0304 — CYLINDER 4 MISFIRE DETECTED —

#### • DTC DETECTING CONDITION:

- Two consecutive driving cycles with fault
- Immediately at fault recognition (A misfire which could damage catalyst occurs.)
- GENERAL DESCRIPTION <Ref. to GD(STi)-96, DTC P0301 — CYLINDER 1 MISFIRE DETECTED — , Diagnostic Trouble Code (DTC) Detecting Criteria.>

#### • TROUBLE SYMPTOM:

- Engine stalls.
- Erroneous idling
- Rough driving

#### CAUTION:

After repair or replacement of faulty parts, conduct Clear Memory Mode <Ref. to EN(STi)-42, OPERATION, Clear Memory Mode.> and Inspection Mode <Ref. to EN(STi)-35, OPERATION, Inspection Mode.>.

# DIAGNOSTIC PROCEDURE WITH DIAGNOSTIC TROUBLE CODE (DTC)

## ENGINE (DIAGNOSTICS)

• WIRING DIAGRAM:

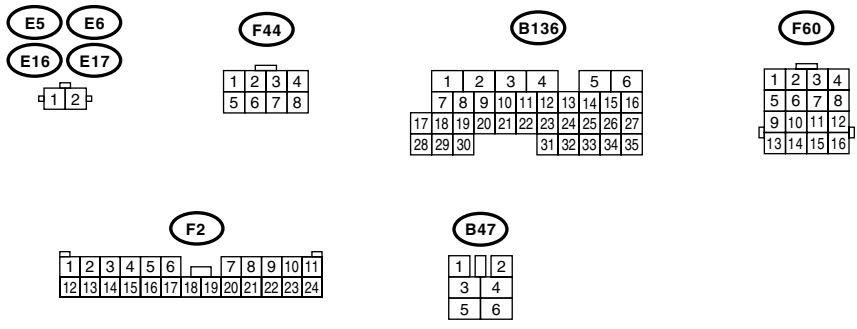
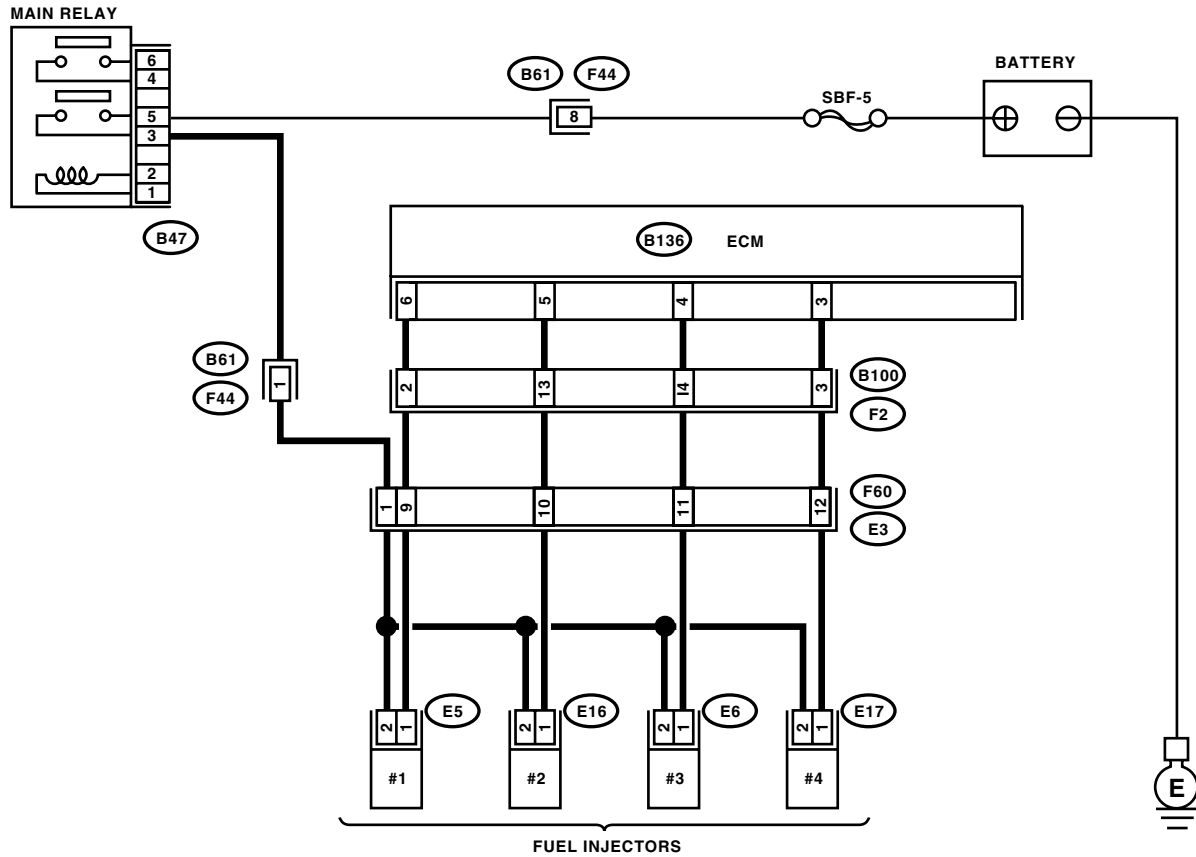

EN-01819

# DIAGNOSTIC PROCEDURE WITH DIAGNOSTIC TROUBLE CODE (DTC)

ENGINE (DIAGNOSTICS)

Step	Check	Yes	No
<b>1</b> <b>CHECK ANY OTHER DTC ON DISPLAY.</b>	Is any other DTC displayed?	Inspect the relevant DTC using "List of Diagnostic Trouble Code (DTC)". <Ref. to EN(STi)-66, List of Diagnostic Trouble Code (DTC).>	Go to step 2.
<b>2</b> <b>CHECK OUTPUT SIGNAL FROM ECM.</b> 1) Turn the ignition switch to ON. 2) Measure the voltage between ECM connector and chassis ground on faulty cylinders. <b>Connector &amp; terminal</b> <i>#1 (B136) No. 6 (+) — Chassis ground (-):</i> <i>#2 (B136) No. 5 (+) — Chassis ground (-):</i> <i>#3 (B136) No. 4 (+) — Chassis ground (-):</i> <i>#4 (B136) No. 3 (+) — Chassis ground (-):</i>	Is the voltage more than 10 V?	Go to step 7.	Go to step 3.
<b>3</b> <b>CHECK HARNESS BETWEEN FUEL INJECTOR AND ECM CONNECTOR.</b> 1) Turn the ignition switch to OFF. 2) Disconnect the connector from fuel injector on faulty cylinders. 3) Disconnect the connector from ECM. 4) Measure the resistance between ECM connector and engine ground on faulty cylinders. <b>Connector &amp; terminal</b> <i>#1 (E5) No. 1 — Engine ground:</i> <i>#2 (E16) No. 1 — Engine ground:</i> <i>#3 (E6) No. 1 — Engine ground:</i> <i>#4 (E17) No. 1 — Engine ground:</i>	Is the resistance more than 1 MΩ?	Go to step 4.	Repair the ground short circuit in harness between fuel injector and ECM connector.
<b>4</b> <b>CHECK HARNESS BETWEEN FUEL INJECTOR AND ECM CONNECTOR.</b> Measure the resistance of harness connector between ECM connector and fuel injector on faulty cylinders. <b>Connector &amp; terminal</b> <i>#1 (B136) No. 6 — (E5) No. 1:</i> <i>#2 (B136) No. 5 — (E16) No. 1:</i> <i>#3 (B136) No. 4 — (E6) No. 1:</i> <i>#4 (B136) No. 3 — (E17) No. 1:</i>	Is the resistance less than 1 Ω?	Go to step 5.	Repair the harness and connector.  NOTE: In this case, repair the following: • Open circuit in harness between ECM and fuel injector connector • Poor contact in coupling connector
<b>5</b> <b>CHECK FUEL INJECTOR.</b> Measure the resistance between fuel injector terminals on faulty cylinder. <b>Terminals</b> <i>No. 1 — No. 2:</i>	Is the resistance 5 — 20 Ω?	Go to step 6.	Replace the faulty fuel injector. <Ref. to FU(STi)-32, Fuel Injector.>

# DIAGNOSTIC PROCEDURE WITH DIAGNOSTIC TROUBLE CODE (DTC)

ENGINE (DIAGNOSTICS)

Step	Check	Yes	No
<p><b>6</b></p> <p><b>CHECK POWER SUPPLY LINE.</b>                      1) Turn the ignition switch to ON.                      2) Measure the voltage between fuel injector and engine ground on faulty cylinders.</p> <p><b>Connector &amp; terminal</b>                      #1 (E5) No. 2 (+) — Engine ground (-):                      #2 (E16) No. 2 (+) — Engine ground (-):                      #3 (E6) No. 2 (+) — Engine ground (-):                      #4 (E17) No. 2 (+) — Engine ground (-):</p>	<p>Is the voltage more than 10 V?</p>	<p>Repair the poor contact in all connectors in fuel injector circuit.</p>	<p>Repair the harness and connector.</p> <p><b>NOTE:</b>                      In this case, repair the following:</p> <ul style="list-style-type: none"> <li>• Open circuit in harness between main relay and fuel injector connector on faulty cylinders</li> <li>• Poor contact in coupling connector</li> <li>• Poor contact in main relay connector</li> <li>• Poor contact in fuel injector connector on faulty cylinders</li> </ul>
<p><b>7</b></p> <p><b>CHECK HARNESS BETWEEN FUEL INJECTOR AND ECM CONNECTOR.</b>                      1) Turn the ignition switch to OFF.                      2) Disconnect the connector from fuel injector on faulty cylinder.                      3) Turn the ignition switch to ON.                      4) Measure the voltage between ECM connector and chassis ground on faulty cylinders.</p> <p><b>Connector &amp; terminal</b>                      #1 (B136) No. 6 (+) — Chassis ground (-):                      #2 (B136) No. 5 (+) — Chassis ground (-):                      #3 (B136) No. 4 (+) — Chassis ground (-):                      #4 (B136) No. 3 (+) — Chassis ground (-):</p>	<p>Is the voltage more than 10 V?</p>	<p>Repair the battery short circuit in harness between ECM and fuel injector. After repair, replace the ECM. &lt;Ref. to FU(STi)-41, Engine Control Module (ECM).&gt;</p>	<p>Go to step 8.</p>
<p><b>8</b></p> <p><b>CHECK FUEL INJECTOR.</b>                      1) Turn the ignition switch to OFF.                      2) Measure the resistance between fuel injector terminals on faulty cylinder.</p> <p><b>Terminals</b>                      No. 1 — No. 2:</p>	<p>Is the resistance less than 1 Ω?</p>	<p>Replace the faulty fuel injector &lt;Ref. to FU(STi)-32, Fuel Injector.&gt; and ECM &lt;Ref. to FU(STi)-41, Engine Control Module (ECM).&gt;</p>	<p>Go to step 9.</p>
<p><b>9</b></p> <p><b>CHECK INSTALLATION OF CAMSHAFT POSITION SENSOR/CRANKSHAFT POSITION SENSOR.</b></p>	<p>Is the camshaft position sensor or crankshaft position sensor loosely installed?</p>	<p>Tighten the camshaft position sensor or crankshaft position sensor.</p>	<p>Go to step 10.</p>
<p><b>10</b></p> <p><b>CHECK CRANKSHAFT SPROCKET.</b>                      Remove the timing belt cover.</p>	<p>Is the crankshaft sprocket rusted or does it have broken teeth?</p>	<p>Replace the crankshaft sprocket. &lt;Ref. to ME(STi)-56, Crankshaft Sprocket.&gt;</p>	<p>Go to step 11.</p>
<p><b>11</b></p> <p><b>CHECK INSTALLATION CONDITION OF TIMING BELT.</b>                      Turn the crankshaft, and align alignment mark on crankshaft sprocket with alignment mark on cylinder block.</p>	<p>Is the timing belt dislocated from its proper position?</p>	<p>Repair the installation condition of timing belt. &lt;Ref. to ME(STi)-46, Timing Belt Assembly.&gt;</p>	<p>Go to step 12.</p>



# DIAGNOSTIC PROCEDURE WITH DIAGNOSTIC TROUBLE CODE (DTC)

## ENGINE (DIAGNOSTICS)

Step	Check	Yes	No
<b>12</b> <b>CHECK FUEL LEVEL.</b>	Is the fuel meter indication higher than the "Lower" level?	Go to step <b>13</b> .	Replenish the fuel so fuel meter indication is higher than the "Lower" level. After replenishing fuel; Go to step <b>13</b> .
<b>13</b> <b>CHECK STATUS OF MALFUNCTION INDICATOR LIGHT.</b> 1)Clear the memory using Subaru Select Monitor. <Ref. to EN(STi)-28, Subaru Select Monitor.> 2)Start the engine, and drive the vehicle more than 10 minutes.	Is the malfunction indicator light coming on or blinking?	Go to step <b>15</b> .	Go to step <b>14</b> .
<b>14</b> <b>CHECK CAUSE OF MISFIRE DIAGNOSED.</b>	Was the cause of misfire diagnosed when the engine is running?	Finish the diagnostics operation, if the engine has no abnormality.	Repair the poor contact. NOTE: In this case, repair the following: • Poor contact in ignition coil connector • Poor contact in fuel injector connector on faulty cylinders • Poor contact in ECM connector • Poor contact in coupling connector
<b>15</b> <b>CHECK AIR INTAKE SYSTEM.</b>	Is there a fault in air intake system?	Repair the air intake system. NOTE: Check the following items: • Are there air leaks or air suction caused by loose or dislocated nuts and bolts? • Are there cracks or any disconnection of hoses?	Go to step <b>16</b> .
<b>16</b> <b>CHECK CYLINDER.</b>	Is there a fault in that cylinder?	Repair or replace the faulty parts. NOTE: Check the following items. • Spark plug • Fuel injector • Compression pressure	Go to DTC P0171 and P0172. <Ref. to EN(STi)-138, DTC P0171 — SYSTEM TOO LEAN (BANK 1) — , Diagnostic Procedure with Diagnostic Trouble Code (DTC).>

# DIAGNOSTIC PROCEDURE WITH DIAGNOSTIC TROUBLE CODE (DTC)

ENGINE (DIAGNOSTICS)

## AT:DTC P0327 — KNOCK SENSOR 1 CIRCUIT LOW INPUT (BANK 1 OR SINGLE SENSOR) —

### • DTC DETECTING CONDITION:

- Immediately at fault recognition
- GENERAL DESCRIPTION <Ref. to GD(STi)-103, DTC P0327 — KNOCK SENSOR 1 CIRCUIT LOW INPUT (BANK 1 OR SINGLE SENSOR) —, Diagnostic Trouble Code (DTC) Detecting Criteria.>

### • TROUBLE SYMPTOM:

- Poor driving performance
- Knocking occurs.

### CAUTION:

After repair or replacement of faulty parts, conduct Clear Memory Mode <Ref. to EN(STi)-42, OPERATION, Clear Memory Mode.> and Inspection Mode <Ref. to EN(STi)-35, OPERATION, Inspection Mode.>.

### • WIRING DIAGRAM:

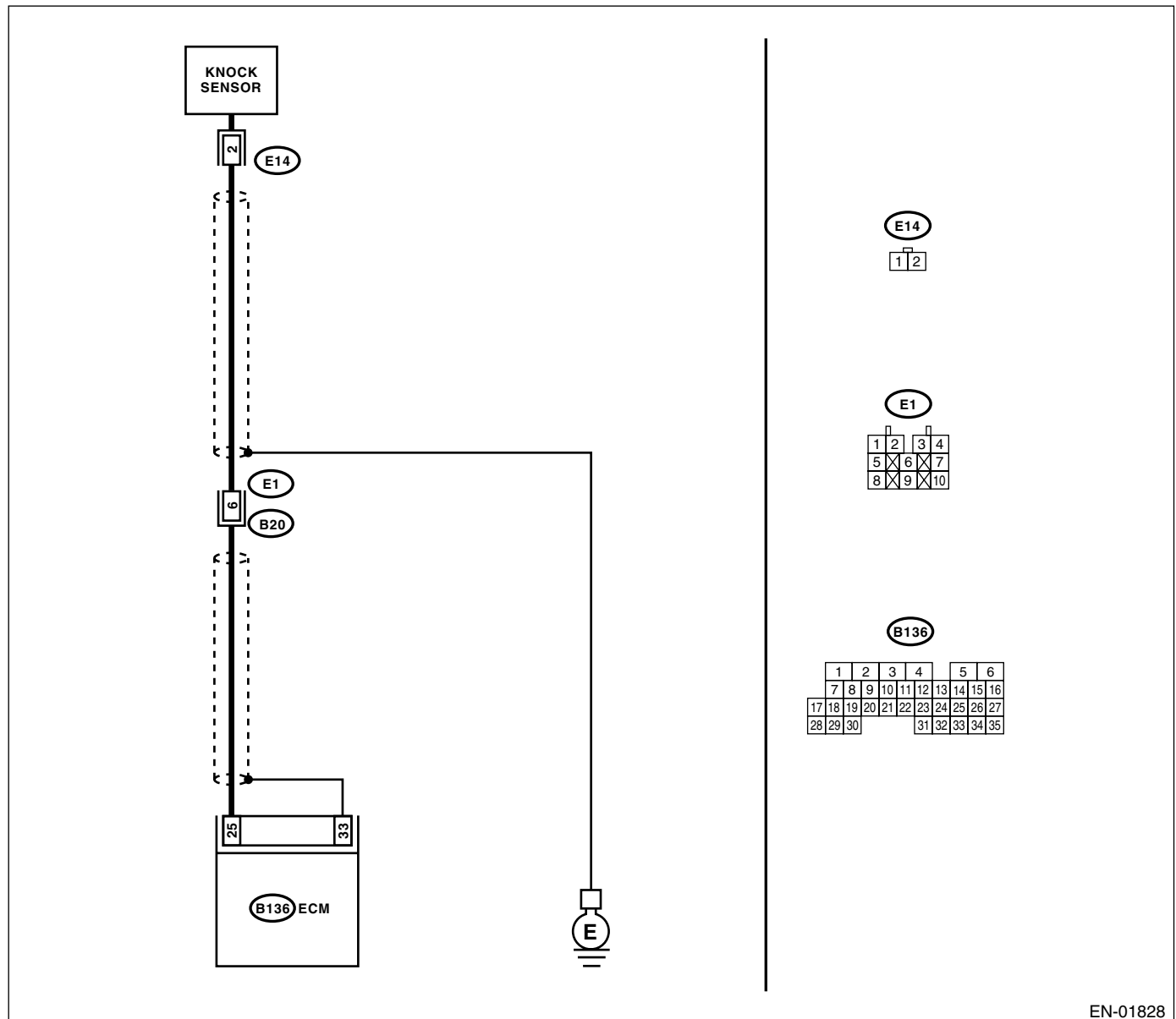

EN-01828

# DIAGNOSTIC PROCEDURE WITH DIAGNOSTIC TROUBLE CODE (DTC)

ENGINE (DIAGNOSTICS)

Step	Check	Yes	No
<p><b>1</b></p> <p><b>CHECK HARNESS BETWEEN KNOCK SENSOR AND ECM CONNECTOR.</b></p> <p>1) Turn the ignition switch to OFF.                      2) Disconnect the connector from ECM.                      3) Measure the resistance between ECM harness connector and chassis ground.</p> <p><b>Connector &amp; terminal</b>  <b>(B136) No. 25 — Chassis ground:</b></p>	<p>Is the resistance more than 700 kΩ?</p>	<p>Go to step 2.</p>	<p>Repair the harness and connector.</p> <p><b>NOTE:</b>                      In this case, repair the following:</p> <ul style="list-style-type: none"> <li>• Open circuit in harness between knock sensor and ECM connector</li> <li>• Poor contact in knock sensor connector</li> <li>• Poor contact in coupling connector</li> </ul>
<p><b>2</b></p> <p><b>CHECK KNOCK SENSOR.</b></p> <p>1) Disconnect the connector from knock sensor.                      2) Measure the resistance between knock sensor connector terminal and engine ground.</p> <p><b>Terminals</b>  <b>No. 2 — Engine ground:</b></p>	<p>Is the resistance more than 700 kΩ?</p>	<p>Go to step 3.</p>	<p>Repair the harness and connector.</p> <p><b>NOTE:</b>                      In this case, repair the following:</p> <ul style="list-style-type: none"> <li>• Poor contact in knock sensor connector</li> <li>• Poor contact in coupling connector</li> </ul>
<p><b>3</b></p> <p><b>CHECK CONDITION OF KNOCK SENSOR INSTALLATION.</b></p>	<p>Is the knock sensor installation bolt tightened securely?</p>	<p>Replace the knock sensor. &lt;Ref. to FU(STi)-29, Knock Sensor.&gt;</p>	<p>Tighten the knock sensor installation bolt securely.</p>

# DIAGNOSTIC PROCEDURE WITH DIAGNOSTIC TROUBLE CODE (DTC)

ENGINE (DIAGNOSTICS)

## AU:DTC P0328 — KNOCK SENSOR 1 CIRCUIT HIGH INPUT (BANK 1 OR SINGLE SENSOR) —

### • DTC DETECTING CONDITION:

- Immediately at fault recognition
- GENERAL DESCRIPTION <Ref. to GD(STi)-105, DTC P0328 — KNOCK SENSOR 1 CIRCUIT HIGH INPUT (BANK 1 OR SINGLE SENSOR) —, Diagnostic Trouble Code (DTC) Detecting Criteria.>

### • TROUBLE SYMPTOM:

- Poor driving performance
- Knocking occurs.

### CAUTION:

After repair or replacement of faulty parts, conduct Clear Memory Mode <Ref. to EN(STi)-42, OPERATION, Clear Memory Mode.> and Inspection Mode <Ref. to EN(STi)-35, OPERATION, Inspection Mode.>.

### • WIRING DIAGRAM:

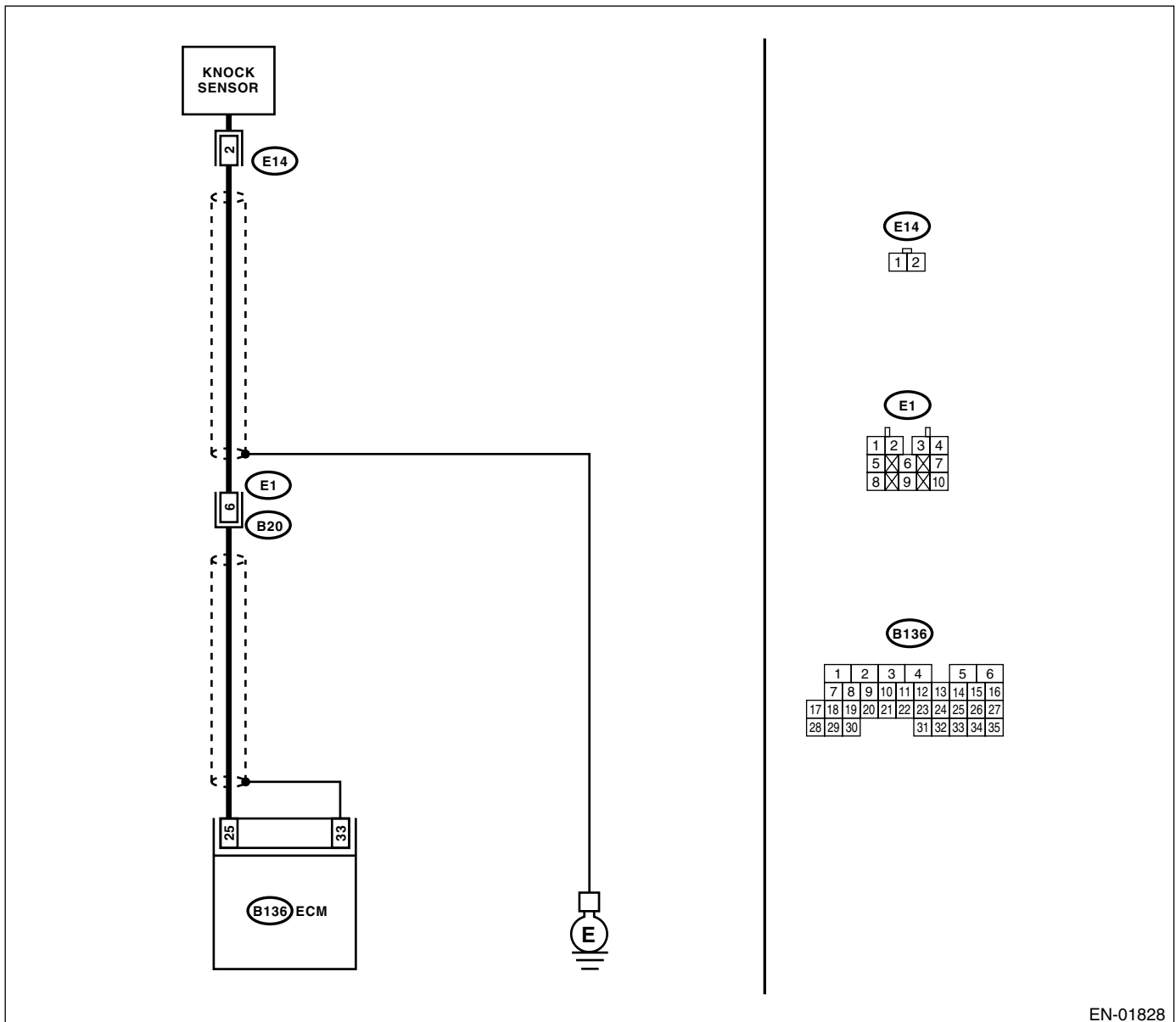

EN-01828

# DIAGNOSTIC PROCEDURE WITH DIAGNOSTIC TROUBLE CODE (DTC)

ENGINE (DIAGNOSTICS)

Step	Check	Yes	No
<p><b>1</b></p> <p><b>CHECK HARNESS BETWEEN KNOCK SENSOR AND ECM CONNECTOR.</b>                      Measure the resistance of harness between ECM connector and chassis ground.  <i><b>Connector &amp; terminal</b></i>  <i><b>(B136) No. 25 — Chassis ground:</b></i></p>	<p>Is the resistance less than 400 kΩ?</p>	<p>Go to step 2.</p>	<p>Go to step 3.</p>
<p><b>2</b></p> <p><b>CHECK KNOCK SENSOR.</b>                      1)Disconnect the connector from knock sensor.                      2)Measure the resistance between knock sensor connector terminal and engine ground.  <i><b>Terminals</b></i>  <i><b>No. 2 — Engine ground:</b></i></p>	<p>Is the resistance less than 400 kΩ?</p>	<p>Replace the knock sensor. &lt;Ref. to FU(STi)-29, Knock Sensor.&gt;</p>	<p>Repair the ground short circuit in harness between knock sensor connector and ECM connector.                       NOTE:                      The harness between both connectors is shielded. Repair the short circuit of harness together with shield.</p>
<p><b>3</b></p> <p><b>CHECK INPUT SIGNAL FOR ECM.</b>                      1)Connect the connectors to ECM and knock sensor.                      2)Turn the ignition switch to ON.                      3)Measure the voltage between ECM and chassis ground.  <i><b>Connector &amp; terminal</b></i>  <i><b>(B136) No. 25 (+) — Chassis ground (-):</b></i></p>	<p>Is the voltage more than 2 V?</p>	<p>Even if malfunction indicator light lights up, the circuit has returned to a normal condition at this time. (However, the possibility of poor contact still remains.)                       NOTE:                      In this case, repair the following:</p> <ul style="list-style-type: none"> <li>• Poor contact in knock sensor connector</li> <li>• Poor contact in ECM connector</li> <li>• Poor contact in coupling connector</li> </ul>	<p>Repair the poor contact in ECM connector.</p>

# DIAGNOSTIC PROCEDURE WITH DIAGNOSTIC TROUBLE CODE (DTC)

ENGINE (DIAGNOSTICS)

## AV:DTC P0335 — CRANKSHAFT POSITION SENSOR “A” CIRCUIT —

### • DTC DETECTING CONDITION:

- Immediately at fault recognition
- GENERAL DESCRIPTION <Ref. to GD(STi)-107, DTC P0335 — CRANKSHAFT POSITION SENSOR “A” CIRCUIT —, Diagnostic Trouble Code (DTC) Detecting Criteria.>

### • TROUBLE SYMPTOM:

- Engine stalls.
- Failure of engine to start

### CAUTION:

After repair or replacement of faulty parts, conduct Clear Memory Mode <Ref. to EN(STi)-42, OPERATION, Clear Memory Mode.> and Inspection Mode <Ref. to EN(STi)-35, OPERATION, Inspection Mode.>.

### • WIRING DIAGRAM:

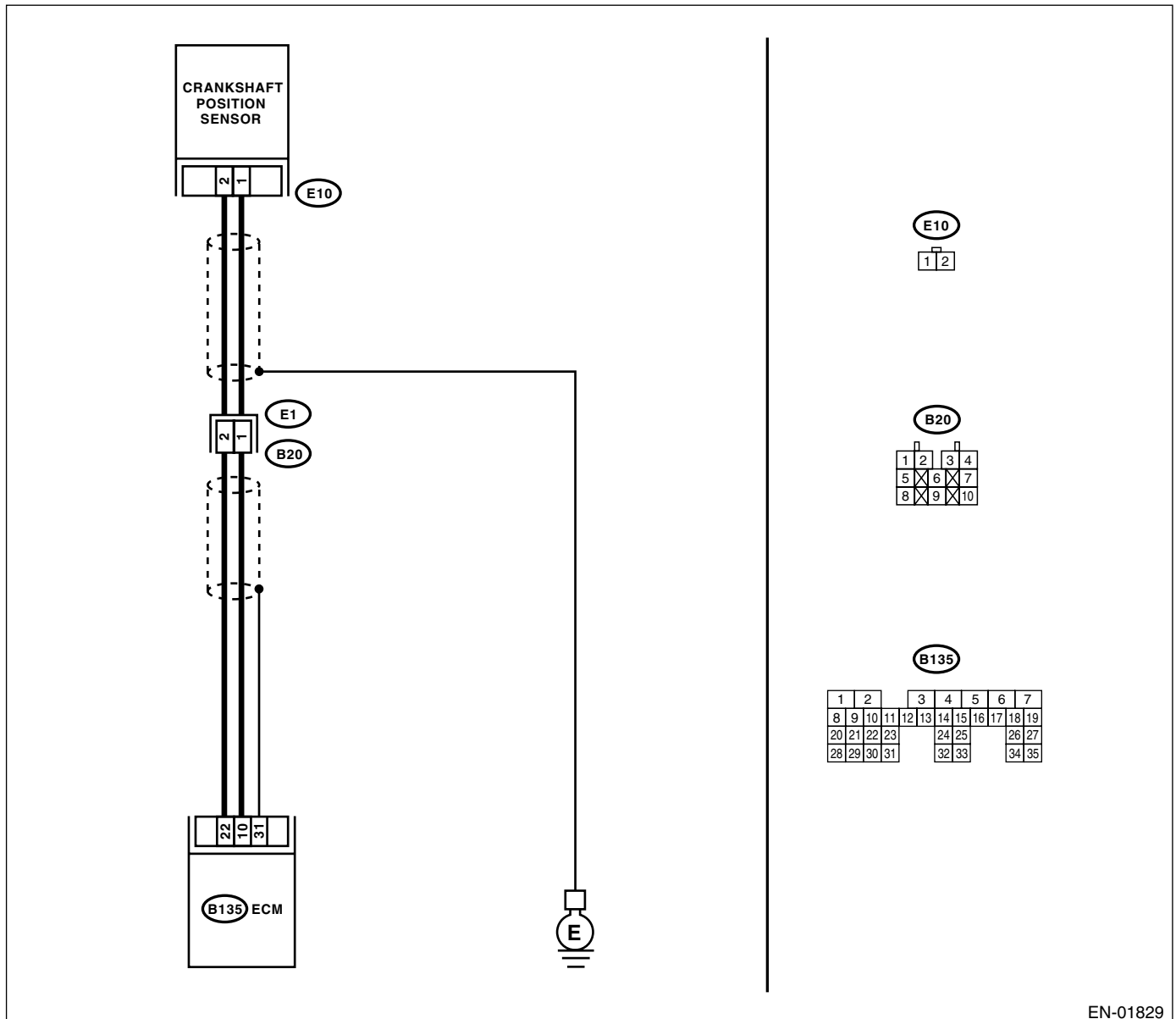

# DIAGNOSTIC PROCEDURE WITH DIAGNOSTIC TROUBLE CODE (DTC)

ENGINE (DIAGNOSTICS)

Step	Check	Yes	No
<p><b>1 CHECK HARNESS BETWEEN CRANKSHAFT POSITION SENSOR AND ECM CONNECTOR.</b>                      1) Turn the ignition switch to OFF.                      2) Disconnect the connector from crankshaft position sensor.                      3) Measure the resistance of harness between crankshaft position sensor connector and engine ground.  <b>Connector &amp; terminal</b>  <b>(E10) No. 1 — Engine ground:</b></p>	<p>Is the resistance more than 100 k<math>\Omega</math>?</p>	<p>Repair the harness and connector.  <b>NOTE:</b>                      In this case, repair the following:                      • Open circuit in harness between crankshaft position sensor and ECM connector                      • Poor contact in ECM connector                      • Poor contact in coupling connector</p>	<p>Go to step 2.</p>
<p><b>2 CHECK HARNESS BETWEEN CRANKSHAFT POSITION SENSOR AND ECM CONNECTOR.</b>                      Measure the resistance of harness between crankshaft position sensor connector and engine ground.  <b>Connector &amp; terminal</b>  <b>(E10) No. 1 — Engine ground:</b></p>	<p>Is the resistance more than 1 M<math>\Omega</math>?</p>	<p>Go to step 3.</p>	<p>Repair the ground short circuit in harness between crankshaft position sensor and ECM connector.  <b>NOTE:</b>                      The harness between both connectors are shielded. Repair ground short circuit in harness together with shield.</p>
<p><b>3 CHECK HARNESS BETWEEN CRANKSHAFT POSITION SENSOR AND ECM CONNECTOR.</b>                      Measure the resistance of harness between crankshaft position sensor connector and engine ground.  <b>Connector &amp; terminal</b>  <b>(E10) No. 2 — Engine ground:</b></p>	<p>Is the resistance less than 5 <math>\Omega</math>?</p>	<p>Go to step 4.</p>	<p>Repair the harness and connector.  <b>NOTE:</b>                      In this case, repair the following:                      • Open circuit in harness between crankshaft position sensor and ECM connector                      • Poor contact in ECM connector                      • Poor contact in coupling connector</p>
<p><b>4 CHECK CONDITION OF CRANKSHAFT POSITION SENSOR.</b></p>	<p>Is the crankshaft position sensor installation bolt tightened securely?</p>	<p>Go to step 5.</p>	<p>Tighten the crankshaft position sensor installation bolt securely.</p>
<p><b>5 CHECK CRANKSHAFT POSITION SENSOR.</b>                      1) Remove the crankshaft position sensor.                      2) Measure the resistance between connector terminals of crankshaft position sensor.  <b>Terminals</b>  <b>No. 1 — No. 2:</b></p>	<p>Is the resistance 1 — 4 k<math>\Omega</math>?</p>	<p>Repair the poor contact in crankshaft position sensor connector.</p>	<p>Replace the crankshaft position sensor. &lt;Ref. to FU(STi)-27, Crankshaft Position Sensor.&gt;</p>

# DIAGNOSTIC PROCEDURE WITH DIAGNOSTIC TROUBLE CODE (DTC)

## ENGINE (DIAGNOSTICS)

### AW:DTC P0336 — CRANKSHAFT POSITION SENSOR “A” CIRCUIT RANGE/PERFORMANCE —

**DTC DETECTING CONDITION:**

- Two consecutive driving cycles with fault
- GENERAL DESCRIPTION <Ref. to GD(STi)-109, DTC P0336 — CRANKSHAFT POSITION SENSOR “A” CIRCUIT RANGE/PERFORMANCE —, Diagnostic Trouble Code (DTC) Detecting Criteria.>

**TROUBLE SYMPTOM:**

- Engine stalls.
- Failure of engine to start

**CAUTION:**

After repair or replacement of faulty parts, conduct Clear Memory Mode <Ref. to EN(STi)-42, OPERATION, Clear Memory Mode.> and Inspection Mode <Ref. to EN(STi)-35, OPERATION, Inspection Mode.>.

**WIRING DIAGRAM:**

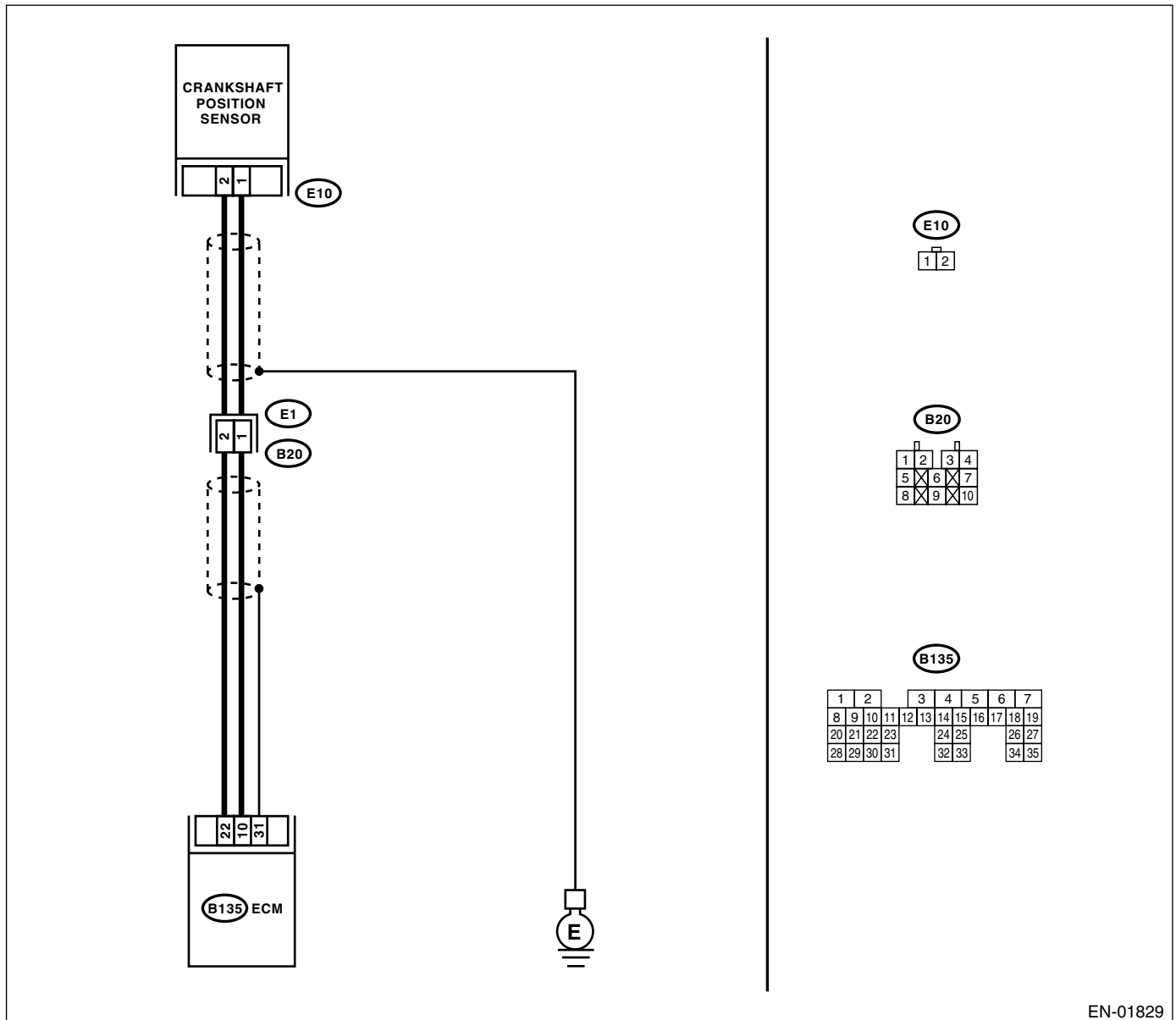



# DIAGNOSTIC PROCEDURE WITH DIAGNOSTIC TROUBLE CODE (DTC)

ENGINE (DIAGNOSTICS)

	Step	Check	Yes	No
1	<b>CHECK ANY OTHER DTC ON DISPLAY.</b>	Is any other DTC displayed?	Inspect the relevant DTC using "List of Diagnostic Trouble Code (DTC)". <Ref. to EN(STi)-66, List of Diagnostic Trouble Code (DTC).>	Go to step 2.
2	<b>CHECK CONDITION OF CRANKSHAFT POSITION SENSOR.</b> Turn the ignition switch to OFF.	Is the crankshaft position sensor installation bolt tightened securely?	Go to step 3.	Tighten the crankshaft position sensor installation bolt securely.
3	<b>CHECK CRANKSHAFT SPROCKET.</b> Remove the front belt cover.	Are the crankshaft sprocket teeth cracked or damaged?	Replace the crankshaft sprocket. <Ref. to FU(STi)-27, Crankshaft Position Sensor.>	Go to step 4.
4	<b>CHECK INSTALLATION CONDITION OF TIMING BELT.</b> Turn the crankshaft, and align alignment mark on crankshaft sprocket with alignment mark on cylinder block.	Is the timing belt dislocated from its proper position?	Repair the installation condition of timing belt. <Ref. to ME(STi)-46, Timing Belt Assembly.>	Replace the crankshaft position sensor. <Ref. to FU(STi)-27, Crankshaft Position Sensor.>

# DIAGNOSTIC PROCEDURE WITH DIAGNOSTIC TROUBLE CODE (DTC)

ENGINE (DIAGNOSTICS)

## AX:DTC P0340 — CAMSHAFT POSITION SENSOR “A” CIRCUIT (BANK 1 OR SINGLE SENSOR) —

### • DTC DETECTING CONDITION:

- Immediately at fault recognition
- GENERAL DESCRIPTION <Ref. to GD(STi)-111, DTC P0340 — CAMSHAFT POSITION SENSOR “A” CIRCUIT (BANK 1 OR SINGLE SENSOR) —, Diagnostic Trouble Code (DTC) Detecting Criteria.>

### • TROUBLE SYMPTOM:

- Engine stalls.
- Failure of engine to start

### CAUTION:

After repair or replacement of faulty parts, conduct Clear Memory Mode <Ref. to EN(STi)-42, OPERATION, Clear Memory Mode.> and Inspection Mode <Ref. to EN(STi)-35, OPERATION, Inspection Mode.>.

### • WIRING DIAGRAM:

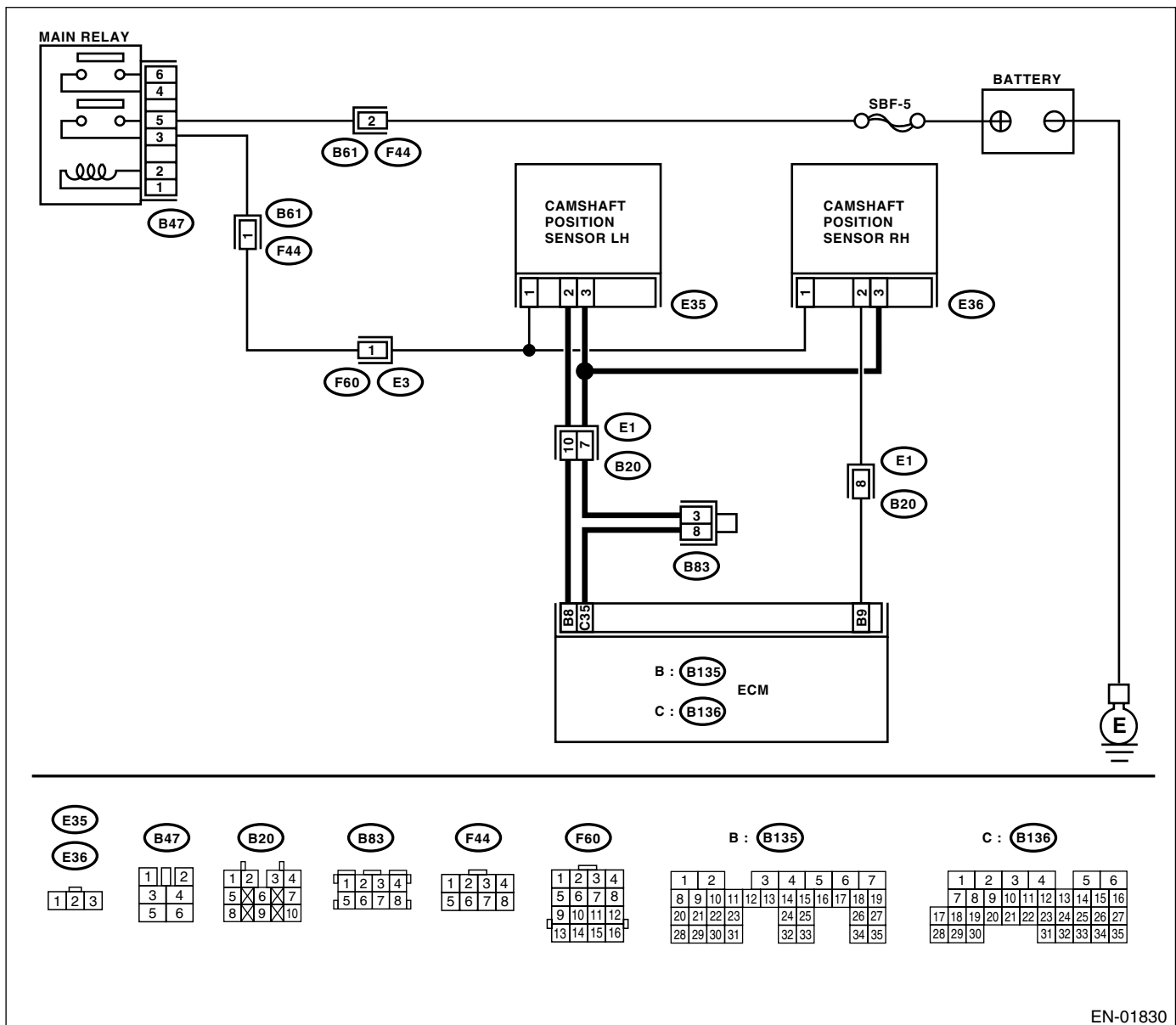

EN-01830

# DIAGNOSTIC PROCEDURE WITH DIAGNOSTIC TROUBLE CODE (DTC)

ENGINE (DIAGNOSTICS)

Step	Check	Yes	No
<b>1 CHECK POWER SUPPLY TO CAMSHAFT POSITION SENSOR.</b> 1) Turn the ignition switch to OFF. 2) Disconnect the connector from camshaft position sensor. 3) Measure the voltage between camshaft position sensor and engine ground. <i>Connector &amp; terminal</i> <i>(E36) No. 1 (+) — Engine ground (-):</i>	Is the voltage more than 10 V?	Repair the battery short circuit between main relay connector and camshaft position sensor connector.	Go to step 2.
<b>2 CHECK POWER SUPPLY TO CAMSHAFT POSITION SENSOR.</b> 1) Turn the ignition switch to ON. 2) Measure the voltage between camshaft position sensor and engine ground. <i>Connector &amp; terminal</i> <i>(E36) No. 1 (+) — Engine ground (-):</i>	Is the voltage more than 10 V?	Go to step 3.	Repair the open or ground short circuit between main relay connector and camshaft position sensor connector.
<b>3 CHECK HARNESS BETWEEN CAMSHAFT POSITION SENSOR AND ECM.</b> 1) Turn the ignition switch to OFF. 2) Disconnect the connector from ECM. 3) Measure the resistance between camshaft position sensor and ECM. <i>Connector &amp; terminal</i> <i>(E36) No. 2 — (E135) No. 9:</i> <i>(E36) No. 3 — (E136) No. 35:</i>	Is the resistance less than 1 $\Omega$ ?	Go to step 4.	Repair the open circuit between camshaft position sensor and ECM.
<b>4 CHECK HARNESS BETWEEN CAMSHAFT POSITION SENSOR AND ECM.</b> Measure the resistance between camshaft position sensor and engine ground. <i>Connector &amp; terminal</i> <i>(E36) No. 2 — Engine ground:</i> <i>(E36) No. 3 — Engine ground:</i>	Is the resistance more than 1 M $\Omega$ ?	Go to step 5.	Repair the ground short circuit between camshaft position sensor and ECM.
<b>5 CHECK CONDITION OF CAMSHAFT POSITION SENSOR.</b>	Is the camshaft position sensor installation bolt tightened securely?	Go to step 6.	Tighten the camshaft position sensor installation bolt securely.
<b>6 CHECK CAMSHAFT POSITION SENSOR.</b> Check the camshaft position sensor waveform. <Ref. to EN(STi)-18, Engine Control Module (ECM) I/O Signal.>	Is any abnormality found in waveform?	Replace the camshaft position sensor. <Ref. to FU(STi)-28, Camshaft Position Sensor.>	Go to step 7.
<b>7 CHECK POOR CONTACT.</b> Check poor contact in ECM connector.	Is there poor contact in ECM connector?	Repair the poor contact in ECM connector.	Replace the ECM. <Ref. to FU(STi)-41, Engine Control Module (ECM).>

# DIAGNOSTIC PROCEDURE WITH DIAGNOSTIC TROUBLE CODE (DTC)

ENGINE (DIAGNOSTICS)

## AY:DTC P0345 — CAMSHAFT POSITION SENSOR “A” CIRCUIT (BANK 2) —

### • DTC DETECTING CONDITION:

- Immediately at fault recognition
- GENERAL DESCRIPTION <Ref. to GD(STi)-113, DTC P0345 — CAMSHAFT POSITION SENSOR “A” CIRCUIT (BANK 2) —, Diagnostic Trouble Code (DTC) Detecting Criteria.>

### • TROUBLE SYMPTOM:

- Engine stalls.
- Failure of engine to start

### CAUTION:

After repair or replacement of faulty parts, conduct Clear Memory Mode <Ref. to EN(STi)-42, OPERATION, Clear Memory Mode.> and Inspection Mode <Ref. to EN(STi)-35, OPERATION, Inspection Mode.>.

### • WIRING DIAGRAM:

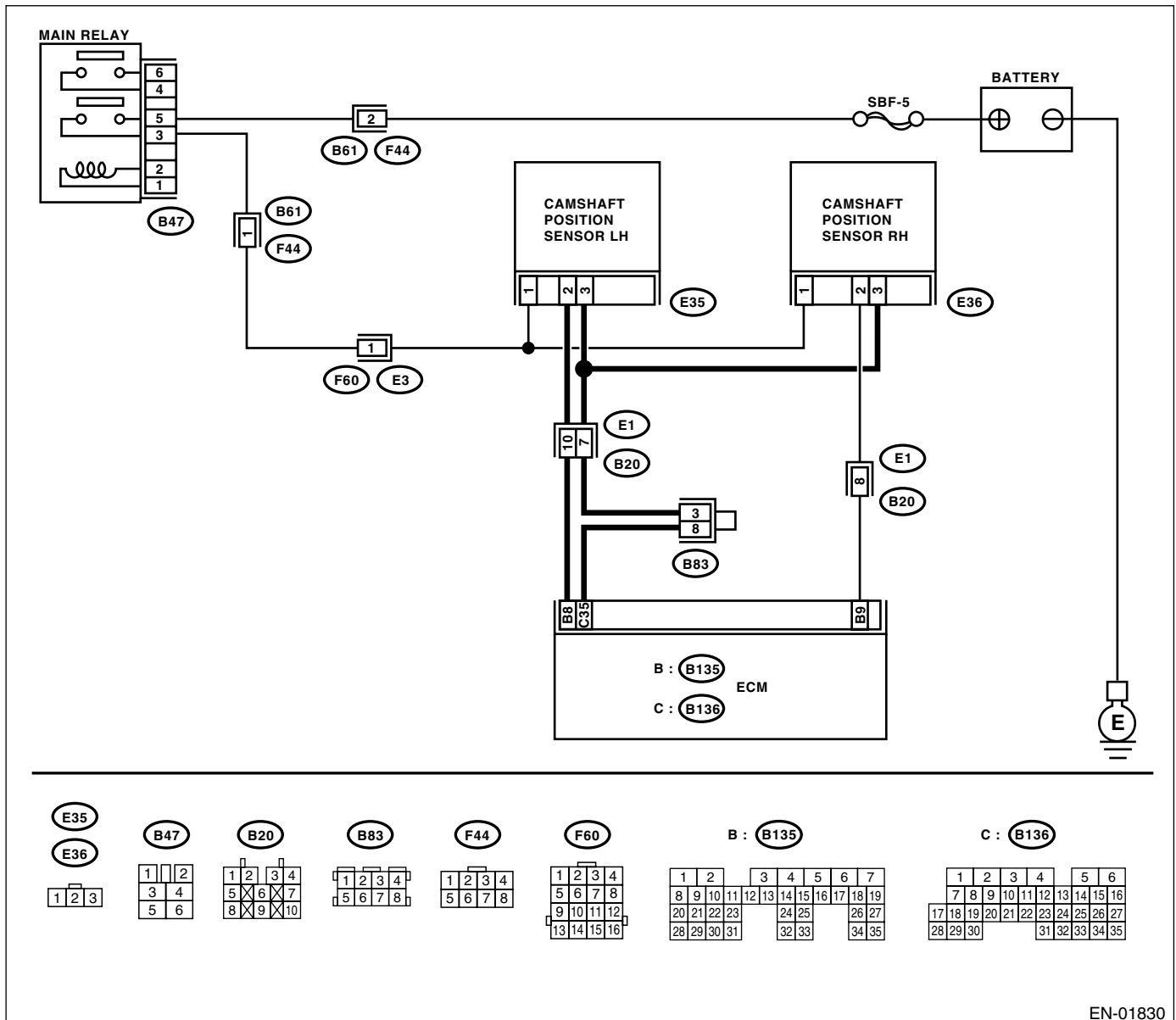

EN-01830

# DIAGNOSTIC PROCEDURE WITH DIAGNOSTIC TROUBLE CODE (DTC)

ENGINE (DIAGNOSTICS)

Step	Check	Yes	No
<b>1 CHECK POWER SUPPLY TO CAMSHAFT POSITION SENSOR.</b> 1) Turn the ignition switch to OFF. 2) Disconnect the connector from camshaft position sensor. 3) Measure the voltage between camshaft position sensor and engine ground. <i>Connector &amp; terminal</i> <i>(E35) No. 1 (+) — Engine ground (-):</i>	Is the voltage more than 10 V?	Repair the battery short circuit between main relay connector and camshaft position sensor connector.	Go to step 2.
<b>2 CHECK POWER SUPPLY TO CAMSHAFT POSITION SENSOR.</b> 1) Turn the ignition switch to ON. 2) Measure the voltage between camshaft position sensor and engine ground. <i>Connector &amp; terminal</i> <i>(E35) No. 1 (+) — Engine ground (-):</i>	Is the voltage more than 10 V?	Go to step 3.	Repair the open or ground short circuit between main relay connector and camshaft position sensor connector.
<b>3 CHECK HARNESS BETWEEN CAMSHAFT POSITION SENSOR AND ECM.</b> 1) Turn the ignition switch to OFF. 2) Disconnect the connector from ECM. 3) Measure the resistance between camshaft position sensor and ECM. <i>Connector &amp; terminal</i> <i>(E35) No. 2 — (B135) No. 8:</i> <i>(E35) No. 3 — (B136) No. 35:</i>	Is the resistance less than 1 $\Omega$ ?	Go to step 4.	Repair the open circuit between camshaft position sensor and ECM.
<b>4 CHECK HARNESS BETWEEN CAMSHAFT POSITION SENSOR AND ECM.</b> Measure the resistance between camshaft position sensor and engine ground. <i>Connector &amp; terminal</i> <i>(E35) No. 2 — Engine ground:</i> <i>(E35) No. 3 — Engine ground:</i>	Is the resistance more than 1 M $\Omega$ ?	Go to step 5.	Repair the ground short circuit between camshaft position sensor and ECM.
<b>5 CHECK CONDITION OF CAMSHAFT POSITION SENSOR.</b>	Is the camshaft position sensor installation bolt tightened securely?	Go to step 6.	Tighten the camshaft position sensor installation bolt securely.
<b>6 CHECK CAMSHAFT POSITION SENSOR.</b> Check the camshaft position sensor waveform. <Ref. to EN(STi)-18, Engine Control Module (ECM) I/O Signal.>	Is any abnormality found in waveform?	Replace the camshaft position sensor. <Ref. to FU(STi)-28, Camshaft Position Sensor.>	Go to step 7.
<b>7 CHECK POOR CONTACT.</b> Check poor contact in ECM connector.	Is there poor contact in ECM connector?	Repair the poor contact in ECM connector.	Replace the ECM. <Ref. to FU(STi)-41, Engine Control Module (ECM).>

# DIAGNOSTIC PROCEDURE WITH DIAGNOSTIC TROUBLE CODE (DTC)

ENGINE (DIAGNOSTICS)

## AZ:DTC P0420 — CATALYST SYSTEM EFFICIENCY BELOW THRESHOLD (BANK 1) —

### • DTC DETECTING CONDITION:

- Two consecutive driving cycles with fault
- GENERAL DESCRIPTION <Ref. to GD(STi)-114, DTC P0420 — CATALYST SYSTEM EFFICIENCY BELOW THRESHOLD (BANK 1) —, Diagnostic Trouble Code (DTC) Detecting Criteria.>

### • TROUBLE SYMPTOM:

- Engine stalls.
- Idle mixture is out of specifications.

### CAUTION:

After repair or replacement of faulty parts, conduct Clear Memory Mode <Ref. to EN(STi)-42, OPERATION, Clear Memory Mode.> and Inspection Mode <Ref. to EN(STi)-35, OPERATION, Inspection Mode.>.

### • WIRING DIAGRAM:

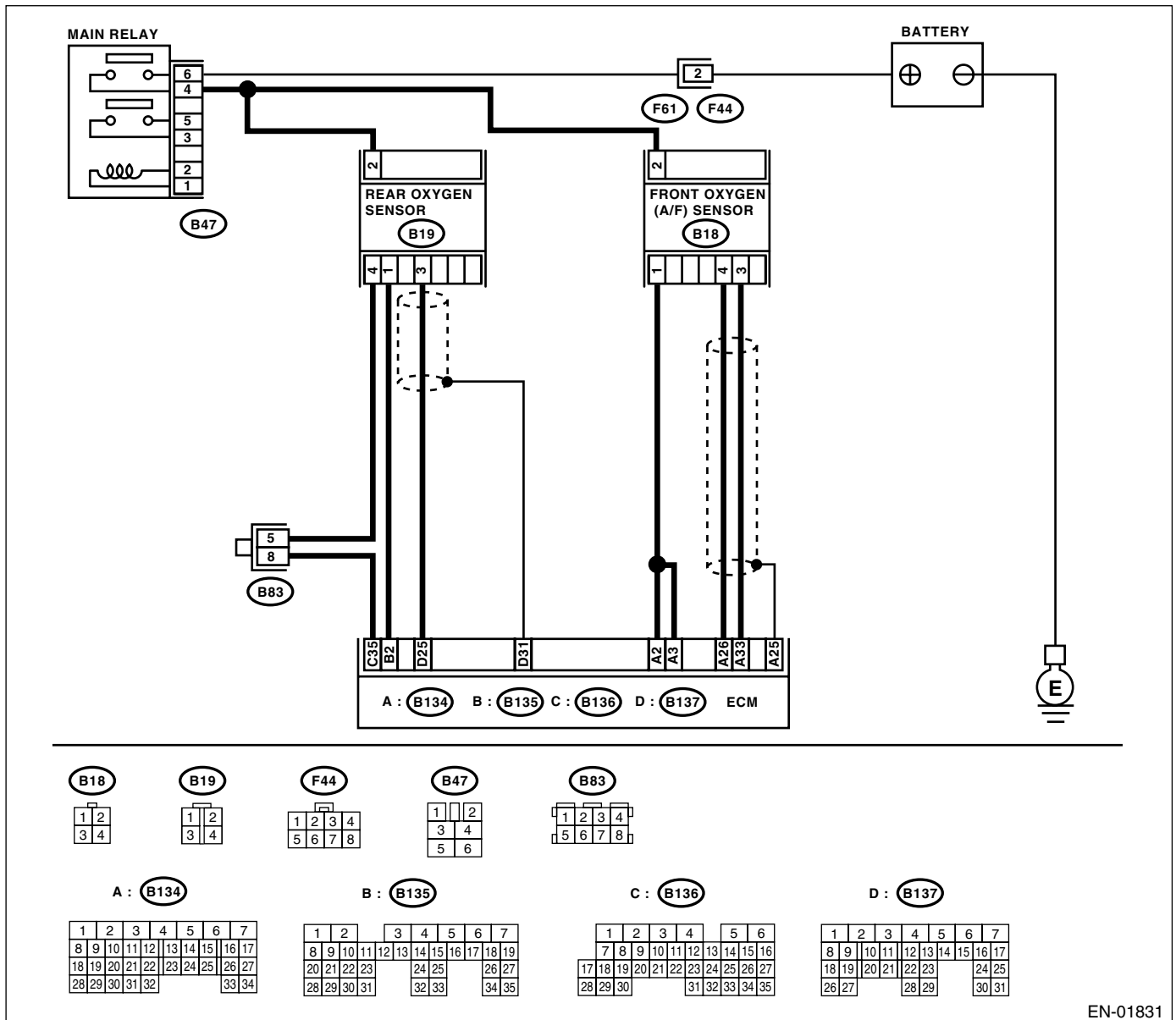

EN-01831

# DIAGNOSTIC PROCEDURE WITH DIAGNOSTIC TROUBLE CODE (DTC)

ENGINE (DIAGNOSTICS)

	Step	Check	Yes	No
1	<b>CHECK ANY OTHER DTC ON DISPLAY.</b>	Is any other DTC displayed?	Inspect the relevant DTC using "List of Diagnostic Trouble Code (DTC)". <Ref. to EN(STi)-66, List of Diagnostic Trouble Code (DTC).> NOTE: In this case, it is not necessary to inspect DTC P0420.	Go to step 2.
2	<b>CHECK EXHAUST SYSTEM.</b> Check for gas leaks or air suction caused by loose or dislocated nuts and bolts, and open hole at exhaust pipes. NOTE: Check the following positions. <ul style="list-style-type: none"> <li>•Between cylinder head and front exhaust pipe</li> <li>•Between front exhaust pipe and front catalytic converter</li> <li>•Between front catalytic converter and rear catalytic converter</li> </ul>	Is there a fault in exhaust system?	Repair or replace the exhaust system. <Ref. to EX(H4DOTC)-2, General Description.>	Go to step 3.
3	<b>CHECK REAR CATALYTIC CONVERTER.</b> Separate the rear catalytic converter from rear exhaust pipe.	Is there damage at rear face of rear catalyst?	Replace the front catalytic converter. <Ref. to EC(STi)-3, Front Catalytic Converter.> and rear catalytic converter <Ref. to EC(STi)-4, Rear Catalytic Converter.>	Go to step 4.
4	<b>CHECK FRONT CATALYTIC CONVERTER.</b> Remove the front catalytic converter.	Is there damage at rear face or front face of front catalyst?	Replace the front catalytic converter. <Ref. to EC(STi)-3, Front Catalytic Converter.>	Contact your SOA Service Center. NOTE: Inspection by DTM is required, because probable cause is deterioration of multiple parts.

## DIAGNOSTIC PROCEDURE WITH DIAGNOSTIC TROUBLE CODE (DTC)

ENGINE (DIAGNOSTICS)

---

### **BA:DTC P0442 — EVAPORATIVE EMISSION CONTROL SYSTEM LEAK DETECTED (SMALL LEAK) —**

• **DTC DETECTING CONDITION:**

- Two consecutive driving cycles with fault
- GENERAL DESCRIPTION <Ref. to GD(STi)-117, DTC P0442 — EVAPORATIVE EMISSION CONTROL SYSTEM LEAK DETECTED (SMALL LEAK) —, Diagnostic Trouble Code (DTC) Detecting Criteria.>

• **TROUBLE SYMPTOM:**

- Fuel odor
- There is a hole of more than 1.0 mm (0.04 in) dia. in evaporation system or fuel tank.

**CAUTION:**

**After repair or replacement of faulty parts, conduct Clear Memory Mode <Ref. to EN(STi)-42, OPERATION, Clear Memory Mode.> and Inspection Mode <Ref. to EN(STi)-35, OPERATION, Inspection Mode.>.**



# DIAGNOSTIC PROCEDURE WITH DIAGNOSTIC TROUBLE CODE (DTC)

ENGINE (DIAGNOSTICS)

• WIRING DIAGRAM:

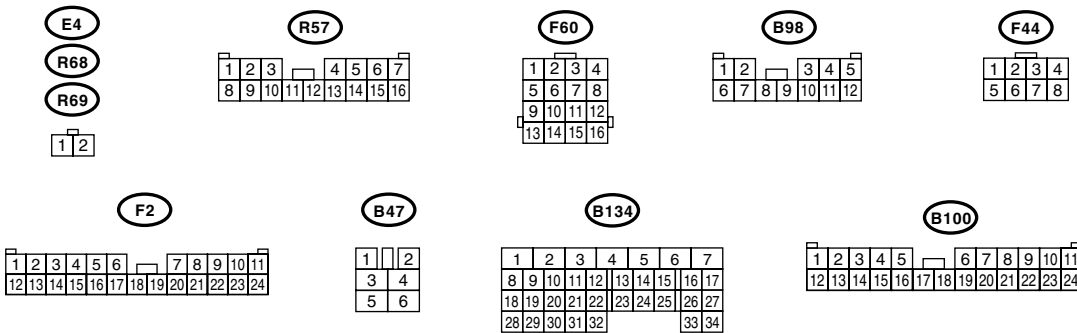
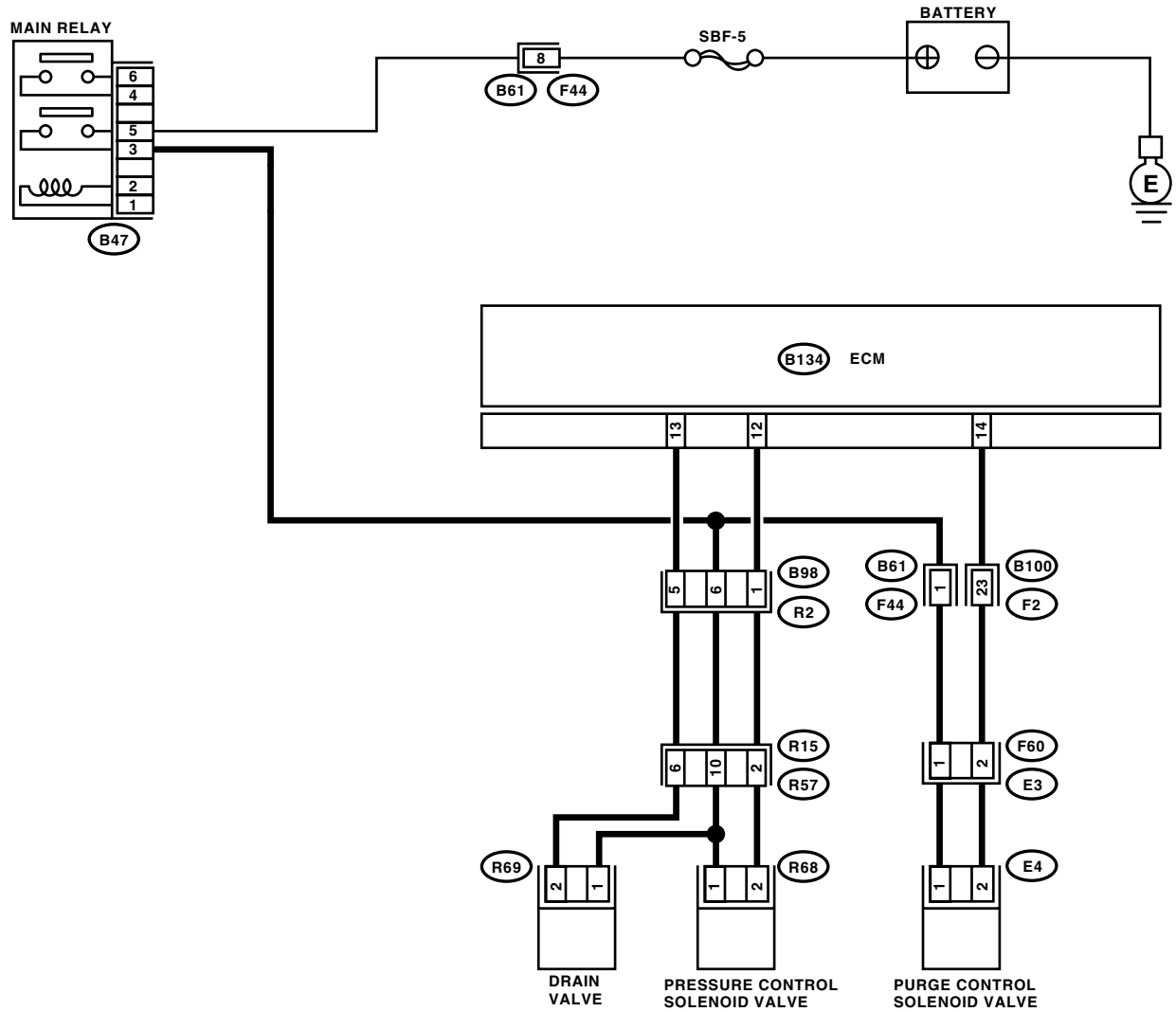

EN-01832

# DIAGNOSTIC PROCEDURE WITH DIAGNOSTIC TROUBLE CODE (DTC)

## ENGINE (DIAGNOSTICS)

	Step	Check	Yes	No
1	<b>CHECK FOR OTHER DTC ON DISPLAY.</b>	Is any other DTC displayed?	Inspect the relevant DTC using "List of Diagnostic Trouble Code (DTC)". <Ref. to EN(STi)-66, List of Diagnostic Trouble Code (DTC).>	Go to step 2.
2	<b>CHECK FUEL FILLER CAP.</b> 1) Turn ignition switch to OFF. 2) Check the fuel filler cap. <b>NOTE:</b> The DTC is stored in memory if fuel filler cap is or was loose or if the cap chain was caught while tightening.	Is the fuel filler cap tightened securely?	Go to step 3.	Tighten fuel filler cap securely.
3	<b>CHECK FUEL FILLER CAP.</b>	Is the fuel filler cap SUBARU genuine?	Go to step 4.	Replace with a SUBARU genuine fuel filler cap.
4	<b>CHECK FUEL FILLER PIPE PACKING.</b>	Is there any damage to the seal between fuel filler cap and fuel filler pipe?	Repair or replace the fuel filler cap and fuel filler pipe. <Ref. to FU(STi)-49, Fuel Filler Pipe.>	Go to step 5.
5	<b>CHECK DRAIN VALVE.</b> 1) Connect the test mode connector. 2) Turn ignition switch to ON. 3) Operate the drain valve. <b>NOTE:</b> Drain valve operation can also be executed using Subaru Select Monitor. For the procedure, refer to "Compulsory Valve Operation Check Mode". <Ref. to EN(STi)-43, Compulsory Valve Operation Check Mode.>	Does the drain valve operate?	Go to step 6.	Replace the drain valve. <Ref. to EC(STi)-18, Drain Valve.>
6	<b>CHECK PURGE CONTROL SOLENOID VALVE.</b> Operate the purge control solenoid valve. <b>NOTE:</b> Purge control solenoid valve operation can also be executed using Subaru Select Monitor. For the procedure, refer to "Compulsory Valve Operation Check Mode". <Ref. to EN(STi)-43, Compulsory Valve Operation Check Mode.>	Does the purge control solenoid valve operate?	Go to step 7.	Replace the purge control solenoid valve. <Ref. to EC(STi)-6, Purge Control Solenoid Valve.>
7	<b>CHECK PRESSURE CONTROL SOLENOID VALVE.</b> Operate the pressure control solenoid valve. <b>NOTE:</b> Pressure control solenoid valve operation can also be executed using Subaru Select Monitor. For the procedure, refer to "Compulsory Valve Operation Check Mode". <Ref. to EN(STi)-43, Compulsory Valve Operation Check Mode.>	Does the pressure control solenoid valve operate?	Go to step 8.	Replace the pressure control solenoid valve. <Ref. to EC(STi)-12, Pressure Control Solenoid Valve.>
8	<b>CHECK EVAPORATIVE EMISSION CONTROL SYSTEM LINE.</b> Turn ignition switch to OFF.	Is there a hole of more than 1.0 mm (0.04 in) dia. on evaporation line?	Repair or replace the evaporation line. <Ref. to FU(STi)-63, Fuel Delivery, Return and Evaporation Lines.>	Go to step 9.

# DIAGNOSTIC PROCEDURE WITH DIAGNOSTIC TROUBLE CODE (DTC)

ENGINE (DIAGNOSTICS)

	Step	Check	Yes	No
9	<b>CHECK CANISTER.</b>	Is the canister damaged or is there a hole of more than 1.0 mm (0.04 in) dia. in it?	Repair or replace the canister. <Ref. to EC(STi)-5, Canister.>	Go to step 10.
10	<b>CHECK FUEL TANK.</b> Remove the fuel tank. <Ref. to FU(STi)-46, Fuel Tank.>	Is the fuel tank damaged or is there a hole of more than 1.0 mm (0.04 in) dia. in it?	Repair or replace the fuel tank. <Ref. to FU(STi)-46, Fuel Tank.>	Go to step 11.
11	<b>CHECK ANY OTHER MECHANICAL TROUBLE IN EVAPORATIVE EMISSION CONTROL SYSTEM.</b>	Are there holes of more than 1.0 mm (0.04 in) dia., cracks, clogging, or disconnections, bend, misconnection of hoses or pipes in evaporative emission control system?	Repair or replace the hoses or pipes.	Contact with SOA Service Center. <b>NOTE:</b> Inspection by DTM is required, because probable cause is deterioration of multiple parts.

# DIAGNOSTIC PROCEDURE WITH DIAGNOSTIC TROUBLE CODE (DTC)

ENGINE (DIAGNOSTICS)

## BB:DTC P0447 — EVAPORATIVE EMISSION CONTROL SYSTEM VENT CONTROL CIRCUIT OPEN —

### • DTC DETECTING CONDITION:

- Two consecutive driving cycles with fault
- GENERAL DESCRIPTION <Ref. to GD(STi)-144, DTC P0447 — EVAPORATIVE EMISSION CONTROL SYSTEM VENT CONTROL CIRCUIT OPEN —, Diagnostic Trouble Code (DTC) Detecting Criteria.>

### CAUTION:

After repair or replacement of faulty parts, conduct Clear Memory Mode <Ref. to EN(STi)-42, OPERATION, Clear Memory Mode.> and Inspection Mode <Ref. to EN(STi)-35, OPERATION, Inspection Mode.>.

### • WIRING DIAGRAM:

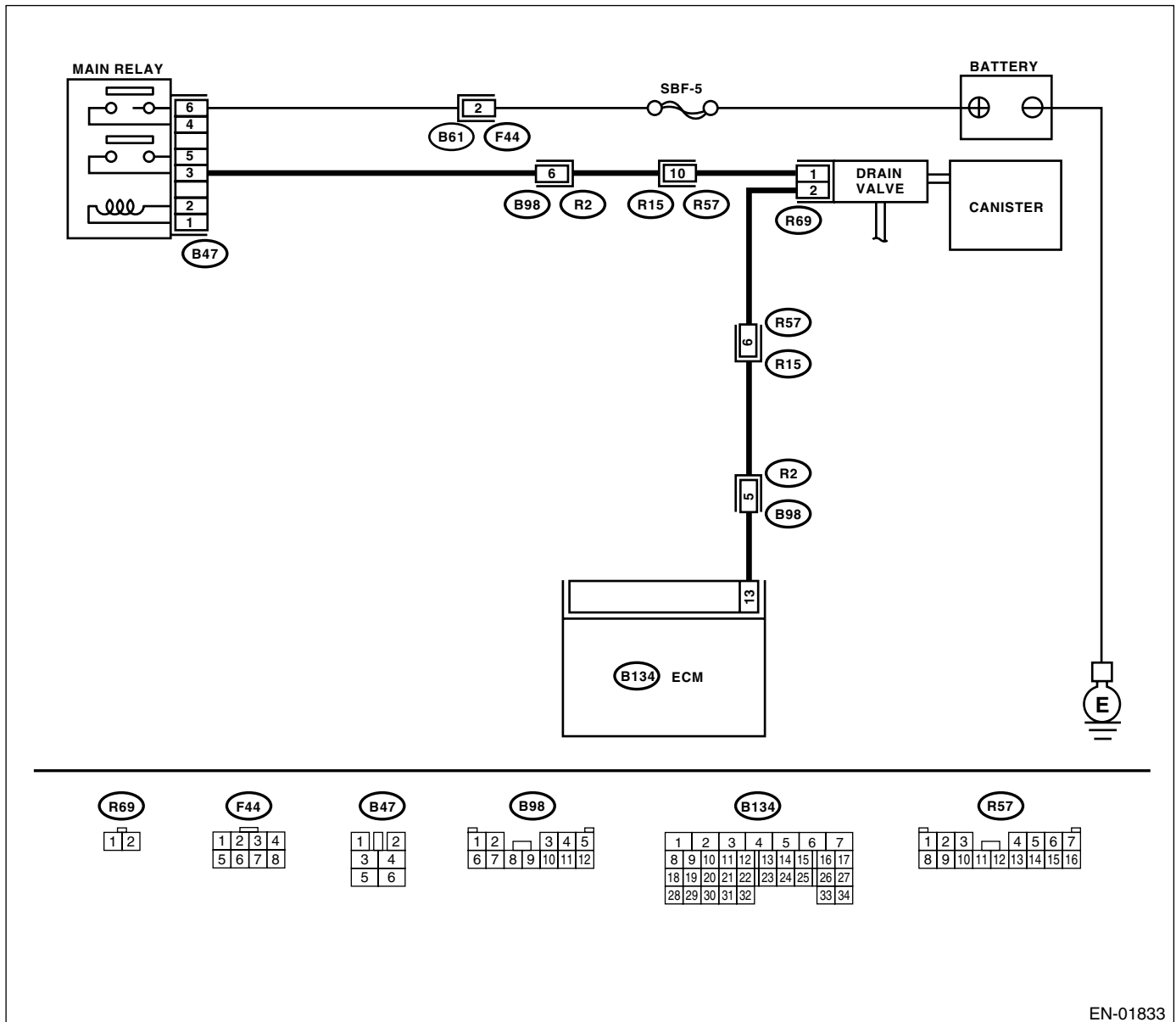

EN-01833

# DIAGNOSTIC PROCEDURE WITH DIAGNOSTIC TROUBLE CODE (DTC)

ENGINE (DIAGNOSTICS)

	Step	Check	Yes	No
1	<b>CHECK OUTPUT SIGNAL FROM ECM.</b> 1) Turn ignition switch to ON. 2) Measure the voltage between ECM and chassis ground. <b>Connector &amp; terminal</b> <b>(B134) No. 13 (+) — Chassis ground (-):</b>	Is the voltage more than 10 V?	Go to step 2.	Go to step 3.
2	<b>CHECK FOR POOR CONTACT.</b> Check for poor contact in ECM connector.	Is there poor contact in ECM connector?	Repair poor contact in ECM connector.	The malfunction indicator light may light up, however, the circuit is returned to the normal status at the moment. (However, the possibility of poor contact still remains.) NOTE: In this case, repair the following: <ul style="list-style-type: none"> <li>• Poor contact in drain valve connector</li> <li>• Poor contact in ECM connector</li> <li>• Poor contact in coupling connector</li> </ul>
3	<b>CHECK HARNESS BETWEEN DRAIN VALVE AND ECM CONNECTOR.</b> 1) Turn ignition switch to OFF. 2) Disconnect the connectors from drain valve and ECM. 3) Measure the resistance of harness between drain valve connector and chassis ground. <b>Connector &amp; terminal</b> <b>(R69) No. 2 — Chassis ground:</b>	Is the resistance more than 1 M $\Omega$ ?	Go to step 4.	Repair short circuit to ground in harness between ECM and drain valve connector.
4	<b>CHECK HARNESS BETWEEN DRAIN VALVE AND ECM CONNECTOR.</b> Measure the resistance of harness between ECM and drain valve connector. <b>Connector &amp; terminal</b> <b>(B134) No. 13 — (R69) No. 2:</b>	Is the resistance less than 1 $\Omega$ ?	Go to step 5.	Repair harness and connector. NOTE: In this case, repair the following: <ul style="list-style-type: none"> <li>• Open circuit in harness between ECM and drain valve connector</li> <li>• Poor contact in coupling connector</li> </ul>
5	<b>CHECK DRAIN VALVE.</b> Measure the resistance between drain valve terminals. <b>Terminals</b> <b>No. 1 — No. 2:</b>	Is the resistance 10 — 100 $\Omega$ ?	Go to step 6.	Replace the drain valve. <Ref. to EC(STi)-18, Drain Valve.>

# DIAGNOSTIC PROCEDURE WITH DIAGNOSTIC TROUBLE CODE (DTC)

ENGINE (DIAGNOSTICS)

Step	Check	Yes	No
<p><b>6</b>     <b>CHECK POWER SUPPLY TO DRAIN VALVE.</b>            1) Turn ignition switch to ON.            2) Measure the voltage between drain valve and chassis ground.  <b>Connector &amp; terminal</b>  <b>(R69) No. 1 (+) — Chassis ground (-):</b></p>	<p>Is the voltage more than 10 V?</p>	<p>Go to step 7.</p>	<p>Repair harness and connector.  <b>NOTE:</b>            In this case, repair the following:</p> <ul style="list-style-type: none"> <li>• Open circuit in harness between main relay and drain valve</li> <li>• Poor contact in coupling connector</li> <li>• Poor contact in main relay connector</li> </ul>
<p><b>7</b>     <b>CHECK FOR POOR CONTACT.</b>            Check for poor contact in drain valve connector.</p>	<p>Is there poor contact in drain valve connector?</p>	<p>Repair poor contact in drain valve connector.</p>	<p>Contact with SOA Service Center.  <b>NOTE:</b>            Inspection by DTM is required, because probable cause is deterioration of multiple parts.</p>

**BC:DTC P0448 — EVAPORATIVE EMISSION CONTROL SYSTEM VENT CONTROL CIRCUIT SHORTED —**

**• DTC DETECTING CONDITION:**

- Two consecutive driving cycles with fault
- GENERAL DESCRIPTION <Ref. to GD(STi)-146, DTC P0448 — EVAPORATIVE EMISSION CONTROL SYSTEM VENT CONTROL CIRCUIT SHORTED —, Diagnostic Trouble Code (DTC) Detecting Criteria.>

**CAUTION:**

After repair or replacement of faulty parts, conduct Clear Memory Mode <Ref. to EN(STi)-42, OPERATION, Clear Memory Mode.> and Inspection Mode <Ref. to EN(STi)-35, OPERATION, Inspection Mode.>.

**• WIRING DIAGRAM:**

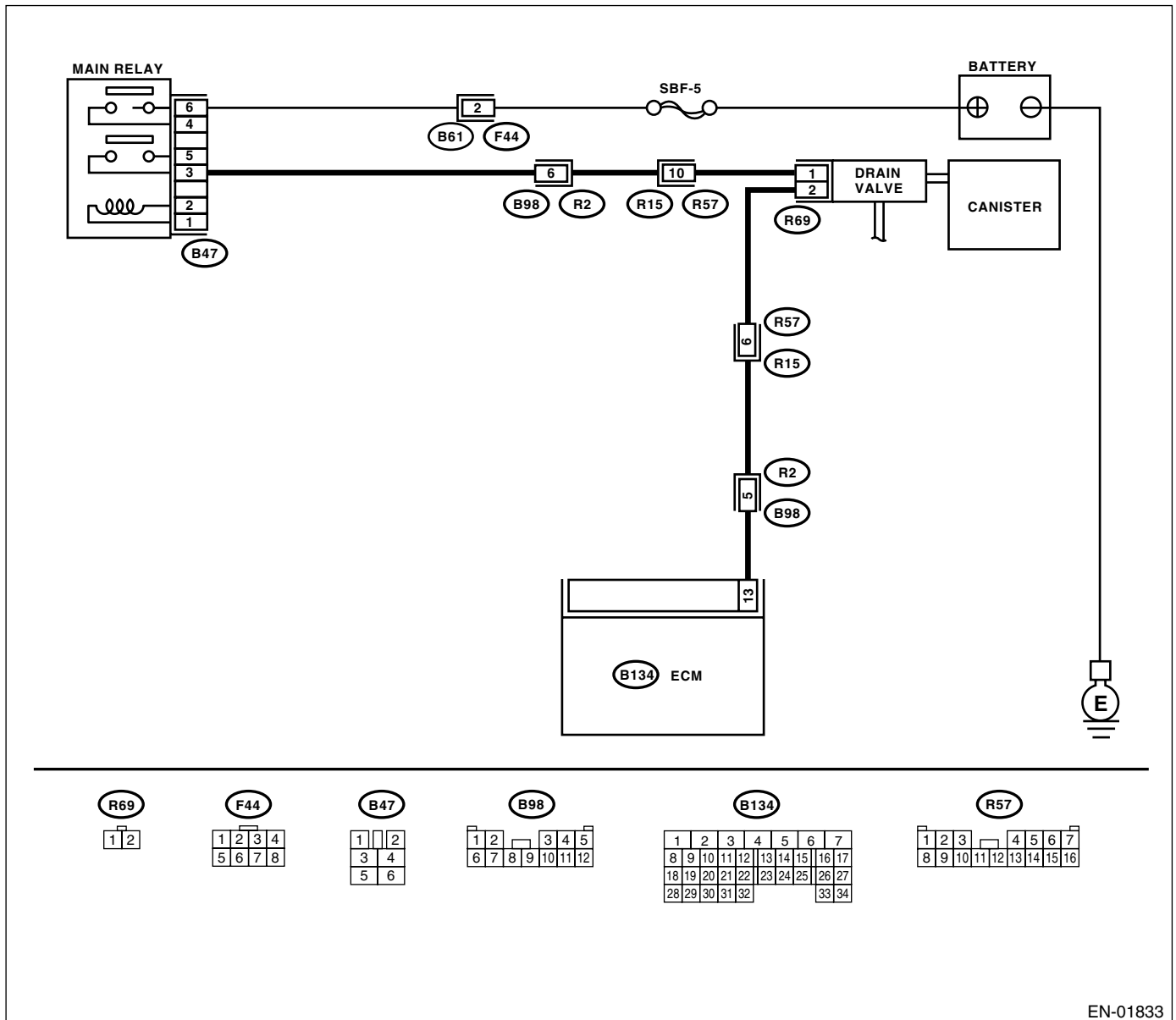

# DIAGNOSTIC PROCEDURE WITH DIAGNOSTIC TROUBLE CODE (DTC)

## ENGINE (DIAGNOSTICS)

Step	Check	Yes	No
<b>1 CHECK INPUT SIGNAL FOR ECM.</b> 1) Turn ignition switch to OFF. 2) Connect the test mode connector at the lower portion of instrument panel (on the driver's side). 3) Turn ignition switch to ON. 4) While operating the drain valve, measure voltage between ECM and chassis ground. NOTE: Drain valve operation can be executed using Subaru Select Monitor. For the procedure, refer to "Compulsory Valve Operation Check Mode". <Ref. to EN(STi)-43, Compulsory Valve Operation Check Mode.> <b>Connector &amp; terminal</b> <b>(B134) No. 13 (+) — Chassis ground (-):</b>	Does the resistance change within 0 — 10 V?	Go to step 2.	The malfunction indicator light may light up, however, the circuit is returned to the normal status at the moment. In this case, repair poor contact in ECM connector.
<b>2 CHECK INPUT SIGNAL FOR ECM.</b> 1) Turn ignition switch to ON. 2) Measure the voltage between ECM and chassis ground. <b>Connector &amp; terminal</b> <b>(B134) No. 13 (+) — Chassis ground (-):</b>	Is the voltage more than 10 V?	Go to step 4.	Go to step 3.
<b>3 CHECK FOR POOR CONTACT.</b> Check for poor contact in ECM connector.	Is there poor contact in ECM connector?	Repair poor contact in ECM connector.	Replace the ECM. <Ref. to FU(STi)-41, Engine Control Module (ECM).>
<b>4 CHECK HARNESS BETWEEN DRAIN VALVE AND ECM CONNECTOR.</b> 1) Turn ignition switch to OFF. 2) Disconnect the connector from drain valve. 3) Turn ignition switch to ON. 4) Measure the voltage between ECM and chassis ground. <b>Connector &amp; terminal</b> <b>(B134) No. 13 (+) — Chassis ground (-):</b>	Is the voltage more than 10 V?	Repair short circuit to battery in harness between ECM and drain valve connector. After repair, replace the ECM. <Ref. to FU(STi)-41, Engine Control Module (ECM).>	Go to step 5.
<b>5 CHECK DRAIN VALVE.</b> 1) Turn ignition switch to OFF. 2) Measure the resistance between drain valve terminals. <b>Terminals</b> <b>No. 1 — No. 2:</b>	Is the resistance less than 1 Ω?	Replace the drain valve <Ref. to EC(STi)-18, Drain Valve.> and ECM <Ref. to FU(STi)-41, Engine Control Module (ECM).>	Go to step 6.
<b>6 CHECK FOR POOR CONTACT.</b> Check for poor contact in ECM connector.	Is there poor contact in ECM connector?	Repair poor contact in ECM connector.	Replace the ECM. <Ref. to FU(STi)-41, Engine Control Module (ECM).>



**BD:DTC P0451 — EVAPORATIVE EMISSION CONTROL SYSTEM PRESSURE SENSOR RANGE/PERFORMANCE —**

**• DTC DETECTING CONDITION:**

- Two consecutive driving cycles with fault
- GENERAL DESCRIPTION <Ref. to GD(STi)-148, DTC P0451 — EVAPORATIVE EMISSION CONTROL SYSTEM PRESSURE SENSOR RANGE/PERFORMANCE —, Diagnostic Trouble Code (DTC) Detecting Criteria.>

**CAUTION:**

After repair or replacement of faulty parts, conduct Clear Memory Mode <Ref. to EN(STi)-42, OPERATION, Clear Memory Mode.> and Inspection Mode <Ref. to EN(STi)-35, OPERATION, Inspection Mode.>.

**• WIRING DIAGRAM:**

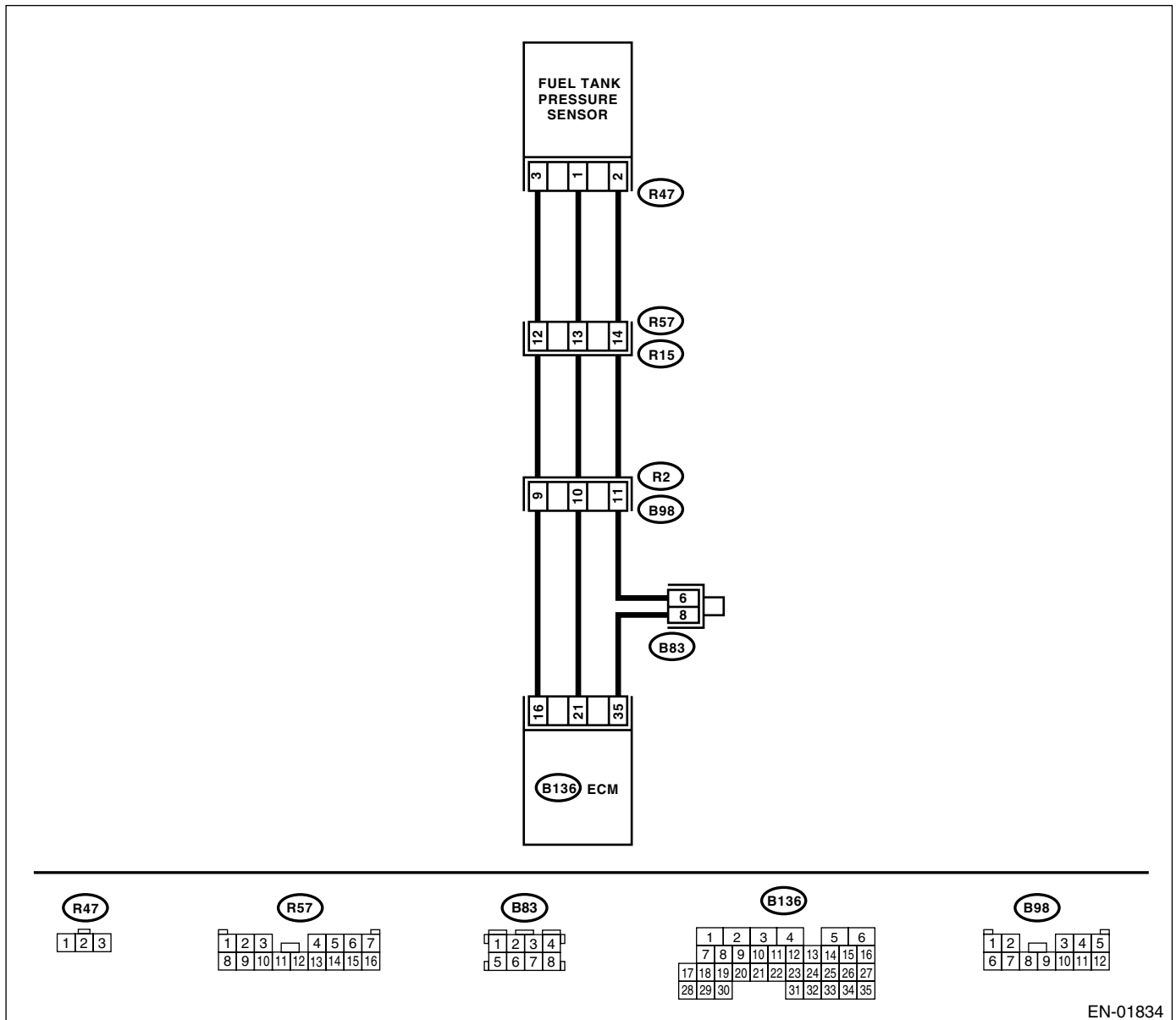

# DIAGNOSTIC PROCEDURE WITH DIAGNOSTIC TROUBLE CODE (DTC)

## ENGINE (DIAGNOSTICS)

	Step	Check	Yes	No
1	<b>CHECK FOR OTHER DTC ON DISPLAY.</b>	Is any other DTC displayed?	Inspect the relevant DTC using "List of Diagnostic Trouble Code (DTC)". <Ref. to EN(STi)-66, List of Diagnostic Trouble Code (DTC).>	Go to step 2.
2	<b>CHECK FUEL FILLER CAP.</b> 1) Turn ignition switch to OFF. 2) Open the fuel flap.	Is the fuel filler cap tightened securely?	Go to step 3.	Tighten fuel filler cap securely.
3	<b>CHECK PRESSURE/VACUUM LINE.</b> NOTE: Check the following items. <ul style="list-style-type: none"><li>• Disconnection, leakage and clogging of the vacuum hoses and pipes between fuel tank pressure sensor and fuel tank</li><li>• Disconnection, leakage and clogging of air ventilation hoses and pipes between fuel filler pipe and fuel tank</li></ul>	Is there a fault in pressure/vacuum line?	Repair or replace the hoses and pipes.	Replace the fuel tank pressure sensor. <Ref. to EC(STi)-10, Fuel Tank Pressure Sensor.>

**BE:DTC P0452 — EVAPORATIVE EMISSION CONTROL SYSTEM PRESSURE SENSOR LOW INPUT —**

**• DTC DETECTING CONDITION:**

- Two consecutive driving cycles with fault
- GENERAL DESCRIPTION <Ref. to GD(STi)-150, DTC P0452 — EVAPORATIVE EMISSION CONTROL SYSTEM PRESSURE SENSOR LOW INPUT —, Diagnostic Trouble Code (DTC) Detecting Criteria.>

**CAUTION:**

After repair or replacement of faulty parts, conduct Clear Memory Mode <Ref. to EN(STi)-42, OPERATION, Clear Memory Mode.> and Inspection Mode <Ref. to EN(STi)-35, OPERATION, Inspection Mode.>.

**• WIRING DIAGRAM:**

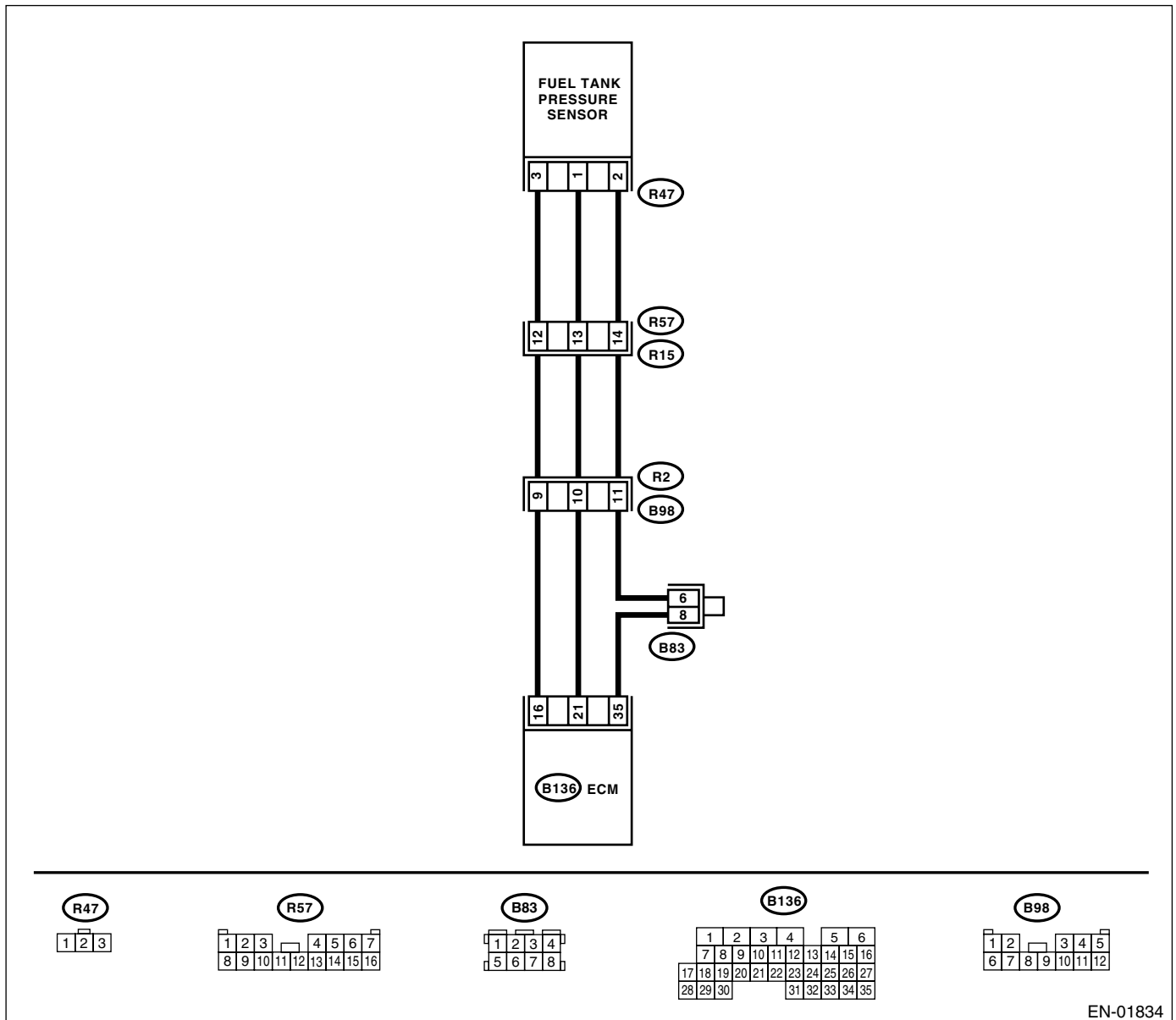

# DIAGNOSTIC PROCEDURE WITH DIAGNOSTIC TROUBLE CODE (DTC)

## ENGINE (DIAGNOSTICS)

Step	Check	Yes	No
<b>1 CHECK CURRENT DATA.</b> 1) Turn ignition switch to OFF. 2) Remove the fuel filler cap. 3) Install the fuel filler cap. 4) Turn ignition switch to ON. 5) Read the data of fuel tank pressure sensor signal using Subaru Select Monitor or the OBD-II general scan tool.  NOTE: • Subaru Select Monitor For detailed operation procedures, refer to "READ CURRENT DATA FOR ENGINE". <Ref. to EN(STi)-28, Subaru Select Monitor.> • OBD-II general scan tool For detailed operation procedures, refer to the OBD-II General Scan Tool Instruction Manual.	Is the measured value less than -2.8 kPa (-21.0 mmHg, -0.827 inHg)?	Go to step 2.	The malfunction indicator light may light up, however, the circuit is returned to the normal status at the moment.
<b>2 CHECK POWER SUPPLY TO FUEL TANK PRESSURE SENSOR.</b> Measure the voltage between ECM connector and chassis ground.  <i>Connector &amp; terminal</i> <i>(B136) No. 16 (+) — Chassis ground (-):</i>	Is the voltage more than 4.5 V?	Go to step 4.	Go to step 3.
<b>3 CHECK POWER SUPPLY TO FUEL TANK PRESSURE SENSOR.</b> Measure the voltage between ECM connector and chassis ground.  <i>Connector &amp; terminal</i> <i>(B136) No. 16 (+) — Chassis ground (-):</i>	Is the voltage more than 4.5 V?	Repair poor contact in ECM connector.	Contact with SOA Service Center.  NOTE: Inspection by DTM is required, because probable cause is deterioration of multiple parts.
<b>4 CHECK INPUT SIGNAL FOR ECM.</b> Measure the voltage between ECM and chassis ground.  <i>Connector &amp; terminal</i> <i>(B136) No. 21 (+) — Chassis ground (-):</i>	Is the voltage less than 0.2 V?	Go to step 6.	Go to step 5.
<b>5 CHECK INPUT SIGNAL FOR ECM. (USING SUBARU SELECT MONITOR.)</b> Read the data of fuel tank pressure sensor signal using Subaru Select Monitor.  NOTE: • Subaru Select Monitor For detailed operation procedures, refer to "READ CURRENT DATA FOR ENGINE". <Ref. to EN(STi)-28, Subaru Select Monitor.>	Does the measured value exceed the specified value by shaking the ECM harness and connector?	Repair poor contact in ECM connector.	Go to step 6.
<b>6 CHECK HARNESS BETWEEN ECM AND COUPLING CONNECTOR IN REAR WIRING HARNESS.</b> 1) Turn ignition switch to OFF. 2) Remove the rear seat cushion. 3) Separate rear wiring harness and fuel tank cord. 4) Turn ignition switch to ON. 5) Measure the voltage between rear wiring harness connector and chassis ground.  <i>Connector &amp; terminal</i> <i>(R15) No. 12 (+) — Chassis ground (-):</i>	Is the voltage more than 4.5 V?	Go to step 7.	Repair harness and connector.  NOTE: In this case, repair the following: • Open circuit in harness between ECM and rear wiring harness connector • Poor contact in coupling connector

# DIAGNOSTIC PROCEDURE WITH DIAGNOSTIC TROUBLE CODE (DTC)

ENGINE (DIAGNOSTICS)

Step	Check	Yes	No
<p><b>7 CHECK HARNESS BETWEEN ECM AND COUPLING CONNECTOR IN REAR WIRING HARNESS.</b>                      1) Turn ignition switch to OFF.                      2) Disconnect the connector from ECM.                      3) Measure the resistance of harness between ECM and rear wiring harness connector.  <b>Connector &amp; terminal</b>  <b>(B136) No. 35 — (R15) No. 14:</b></p>	<p>Is the resistance less than 1 <math>\Omega</math>?</p>	<p>Go to step <b>8</b>.</p>	<p>Repair harness and connector.                      NOTE:                      In this case, repair the following:</p> <ul style="list-style-type: none"> <li>• Open circuit in harness between ECM and rear wiring harness connector</li> <li>• Poor contact in coupling connector</li> <li>• Poor contact in joint connector</li> </ul>
<p><b>8 CHECK HARNESS BETWEEN ECM AND COUPLING CONNECTOR IN REAR WIRING HARNESS.</b>                      Measure the resistance of harness between rear wiring harness connector and chassis ground.  <b>Connector &amp; terminal</b>  <b>(R15) No. 14 — Chassis ground:</b></p>	<p>Is the resistance more than 1 <math>M\Omega</math>?</p>	<p>Go to step <b>9</b>.</p>	<p>Repair short circuit to ground in harness between ECM and rear wiring harness connector.</p>
<p><b>9 CHECK FUEL TANK CORD.</b>                      1) Disconnect the connector from fuel tank pressure sensor.                      2) Measure the resistance of fuel tank cord.  <b>Connector &amp; terminal</b>  <b>(R57) No. 12 — (R47) No. 3:</b></p>	<p>Is the resistance less than 1 <math>\Omega</math>?</p>	<p>Go to step <b>10</b>.</p>	<p>Repair open circuit in fuel tank cord.</p>
<p><b>10 CHECK FUEL TANK CORD.</b>                      Measure the resistance of fuel tank cord.  <b>Connector &amp; terminal</b>  <b>(R57) No. 14 — (R47) No. 2:</b></p>	<p>Is the resistance less than 1 <math>\Omega</math>?</p>	<p>Go to step <b>11</b>.</p>	<p>Repair open circuit in fuel tank cord.</p>
<p><b>11 CHECK FUEL TANK CORD.</b>                      Measure the resistance of harness between fuel tank pressure sensor connector and engine ground.  <b>Connector &amp; terminal</b>  <b>(R47) No. 1 — Chassis ground:</b></p>	<p>Is the resistance more than 1 <math>M\Omega</math>?</p>	<p>Go to step <b>12</b>.</p>	<p>Repair short circuit to ground in fuel tank cord.</p>
<p><b>12 CHECK FOR POOR CONTACT.</b>                      Check for poor contact in fuel tank pressure sensor connector.</p>	<p>Is there poor contact in fuel tank pressure sensor connector?</p>	<p>Repair poor contact in fuel tank pressure sensor connector.</p>	<p>Replace the fuel tank pressure sensor. &lt;Ref. to EC(STi)-10, Fuel Tank Pressure Sensor.&gt;</p>

# DIAGNOSTIC PROCEDURE WITH DIAGNOSTIC TROUBLE CODE (DTC)

ENGINE (DIAGNOSTICS)

## BF:DTC P0453 — EVAPORATIVE EMISSION CONTROL SYSTEM PRESSURE SENSOR HIGH INPUT —

### • DTC DETECTING CONDITION:

- Two consecutive driving cycles with fault
- GENERAL DESCRIPTION <Ref. to GD(STi)-152, DTC P0453 — EVAPORATIVE EMISSION CONTROL SYSTEM PRESSURE SENSOR HIGH INPUT —, Diagnostic Trouble Code (DTC) Detecting Criteria.>

### CAUTION:

After repair or replacement of faulty parts, conduct Clear Memory Mode <Ref. to EN(STi)-42, OPERATION, Clear Memory Mode.> and Inspection Mode <Ref. to EN(STi)-35, OPERATION, Inspection Mode.>.

### • WIRING DIAGRAM:

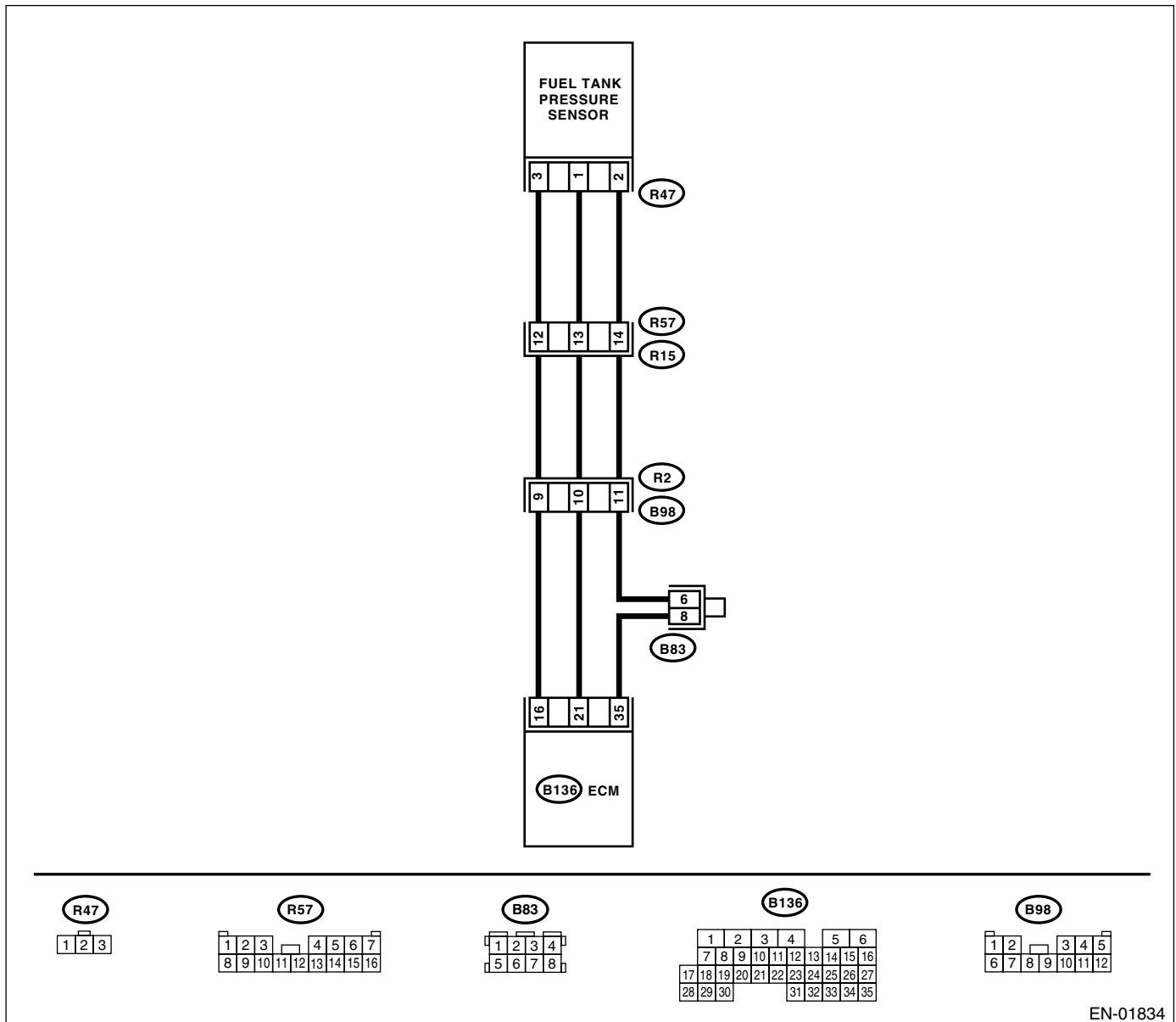

EN-01834

# DIAGNOSTIC PROCEDURE WITH DIAGNOSTIC TROUBLE CODE (DTC)

ENGINE (DIAGNOSTICS)

Step	Check	Yes	No
<b>1 CHECK CURRENT DATA.</b> 1) Turn ignition switch to OFF. 2) Remove the fuel filler cap. 3) Install the fuel filler cap. 4) Turn ignition switch to ON. 5) Read the data of fuel tank pressure sensor signal using Subaru Select Monitor or the OBD-II general scan tool.  NOTE: • Subaru Select Monitor For detailed operation procedures, refer to "READ CURRENT DATA FOR ENGINE". <Ref. to EN(STi)-28, Subaru Select Monitor.> • OBD-II general scan tool For detailed operation procedures, refer to the OBD-II General Scan Tool Instruction Manual.	Is the measured value more than 2.8 kPa (21.0 mmHg, 0.827 inHg)	Go to step 11.	Go to step 2.
<b>2 CHECK POWER SUPPLY TO FUEL TANK PRESSURE SENSOR.</b> Measure the voltage between ECM connector and chassis ground.  <i>Connector &amp; terminal</i> <i>(B136) No. 16 (+) — Chassis ground (-):</i>	Is the voltage more than 4.5 V?	Go to step 4.	Go to step 3.
<b>3 CHECK POWER SUPPLY TO FUEL TANK PRESSURE SENSOR.</b> Measure the voltage between ECM connector and chassis ground.  <i>Connector &amp; terminal</i> <i>(B136) No. 16 (+) — Chassis ground (-):</i>	Does the measured value exceed the specified value by shaking the ECM harness and connector?	Repair poor contact in ECM connector.	Replace the ECM. <Ref. to FU(STi)-41, Engine Control Module (ECM).>
<b>4 CHECK INPUT SIGNAL FOR ECM.</b> Measure the voltage between ECM and chassis ground.  <i>Connector &amp; terminal</i> <i>(B136) No. 21 (+) — Chassis ground (-):</i>	Is the voltage less than 0.2 V?	Go to step 6.	Go to step 5.
<b>5 CHECK INPUT SIGNAL FOR ECM. (USING SUBARU SELECT MONITOR.)</b> Read the data of fuel tank pressure sensor signal using Subaru Select Monitor.  NOTE: • Subaru Select Monitor For detailed operation procedures, refer to "READ CURRENT DATA FOR ENGINE". <Ref. to EN(STi)-28, Subaru Select Monitor.>	Does the measured value exceed -2.8 kPa (-21.0 mmHg, -0.827 inHg) by shaking the ECM harness and connector?	Repair poor contact in ECM connector.	Go to step 6.
<b>6 CHECK HARNESS BETWEEN ECM AND COUPLING CONNECTOR IN REAR WIRING HARNESS.</b> 1) Turn ignition switch to OFF. 2) Remove the rear seat cushion. 3) Separate rear wiring harness and fuel tank cord. 4) Turn ignition switch to ON. 5) Measure the voltage between rear wiring harness connector and chassis ground.  <i>Connector &amp; terminal</i> <i>(R15) No. 12 (+) — Chassis ground (-):</i>	Is the voltage more than 4.5 V?	Go to step 7.	Repair harness and connector.  NOTE: In this case, repair the following: • Open circuit in harness between ECM and rear wiring harness connector • Poor contact in coupling connector

# DIAGNOSTIC PROCEDURE WITH DIAGNOSTIC TROUBLE CODE (DTC)

## ENGINE (DIAGNOSTICS)

Step	Check	Yes	No
<b>7</b> <b>CHECK HARNESS BETWEEN ECM AND COUPLING CONNECTOR IN REAR WIRING HARNESS.</b> 1) Turn ignition switch to OFF. 2) Disconnect the connector from ECM. 3) Measure the resistance of harness between ECM and rear wiring harness connector. <b>Connector &amp; terminal</b> <b>(B136) No. 21 — (R15) No. 13:</b> <b>(B136) No. 35 — (R15) No. 14:</b>	Is the resistance less than 1 $\Omega$ ?	Go to step <b>8</b> .	Repair harness and connector. NOTE: In this case, repair the following: • Open circuit in harness between ECM and rear wiring harness connector • Poor contact in coupling connector
<b>8</b> <b>CHECK FUEL TANK CORD.</b> 1) Disconnect the connector from fuel tank pressure sensor. 2) Measure the resistance of fuel tank cord. <b>Connector &amp; terminal</b> <b>(R57) No. 13 — (R47) No. 1:</b>	Is the resistance less than 1 $\Omega$ ?	Go to step <b>9</b> .	Repair open circuit in fuel tank cord.
<b>9</b> <b>CHECK FUEL TANK CORD.</b> Measure the resistance of fuel tank cord. <b>Connector &amp; terminal</b> <b>(R57) No. 14 — (R47) No. 2:</b>	Is the resistance less than 1 $\Omega$ ?	Go to step <b>10</b> .	Repair open circuit in fuel tank cord.
<b>10</b> <b>CHECK FOR POOR CONTACT.</b> Check for poor contact in fuel tank pressure sensor connector.	Is there poor contact in fuel tank pressure sensor connector?	Repair poor contact in fuel tank pressure sensor connector.	Replace the fuel tank pressure sensor. <Ref. to EC(STi)-10, Fuel Tank Pressure Sensor.>
<b>11</b> <b>CHECK HARNESS BETWEEN ECM AND FUEL TANK PRESSURE SENSOR CONNECTOR.</b> 1) Turn ignition switch to OFF. 2) Disconnect the connector from fuel tank pressure sensor. 3) Turn ignition switch to ON. 4) Read the data of fuel tank pressure sensor signal using Subaru Select Monitor or the OBD-II general scan tool. NOTE: • Subaru Select Monitor For detailed operation procedures, refer to "READ CURRENT DATA FOR ENGINE". <Ref. to EN(STi)-28, Subaru Select Monitor.> • OBD-II general scan tool For detailed operation procedures, refer to the OBD-II General Scan Tool Instruction Manual.	Is the measured value more than 2.8 kPa (21.0 mmHg, 0.827 inHg)?	Repair short circuit to battery in harness between ECM and fuel tank pressure sensor connector.	Replace the fuel tank pressure sensor. <Ref. to EC(STi)-10, Fuel Tank Pressure Sensor.>



## DIAGNOSTIC PROCEDURE WITH DIAGNOSTIC TROUBLE CODE (DTC)

ENGINE (DIAGNOSTICS)

### **BG:DTC P0456 — EVAPORATIVE EMISSION CONTROL SYSTEM LEAK DETECTED (VERY SMALL LEAK) —**

#### **• DTC DETECTING CONDITION:**

- Two consecutive driving cycles with fault
- GENERAL DESCRIPTION <Ref. to GD(STi)-154, DTC P0456 — EVAPORATIVE EMISSION CONTROL SYSTEM LEAK DETECTED (VERY SMALL LEAK) —, Diagnostic Trouble Code (DTC) Detecting Criteria.>

#### **• TROUBLE SYMPTOM:**

- Fuel odor
- There is a hole of more than 0.5 mm (0.020 in) dia. in evaporation system or fuel tank.

#### **CAUTION:**

**After repair or replacement of faulty parts, conduct Clear Memory Mode <Ref. to EN(STi)-42, OPERATION, Clear Memory Mode.> and Inspection Mode <Ref. to EN(STi)-35, OPERATION, Inspection Mode.>.**

# DIAGNOSTIC PROCEDURE WITH DIAGNOSTIC TROUBLE CODE (DTC)

## ENGINE (DIAGNOSTICS)

• WIRING DIAGRAM:

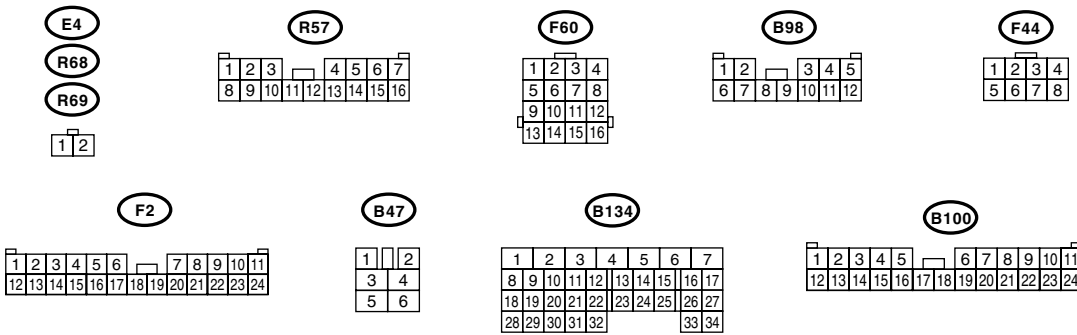
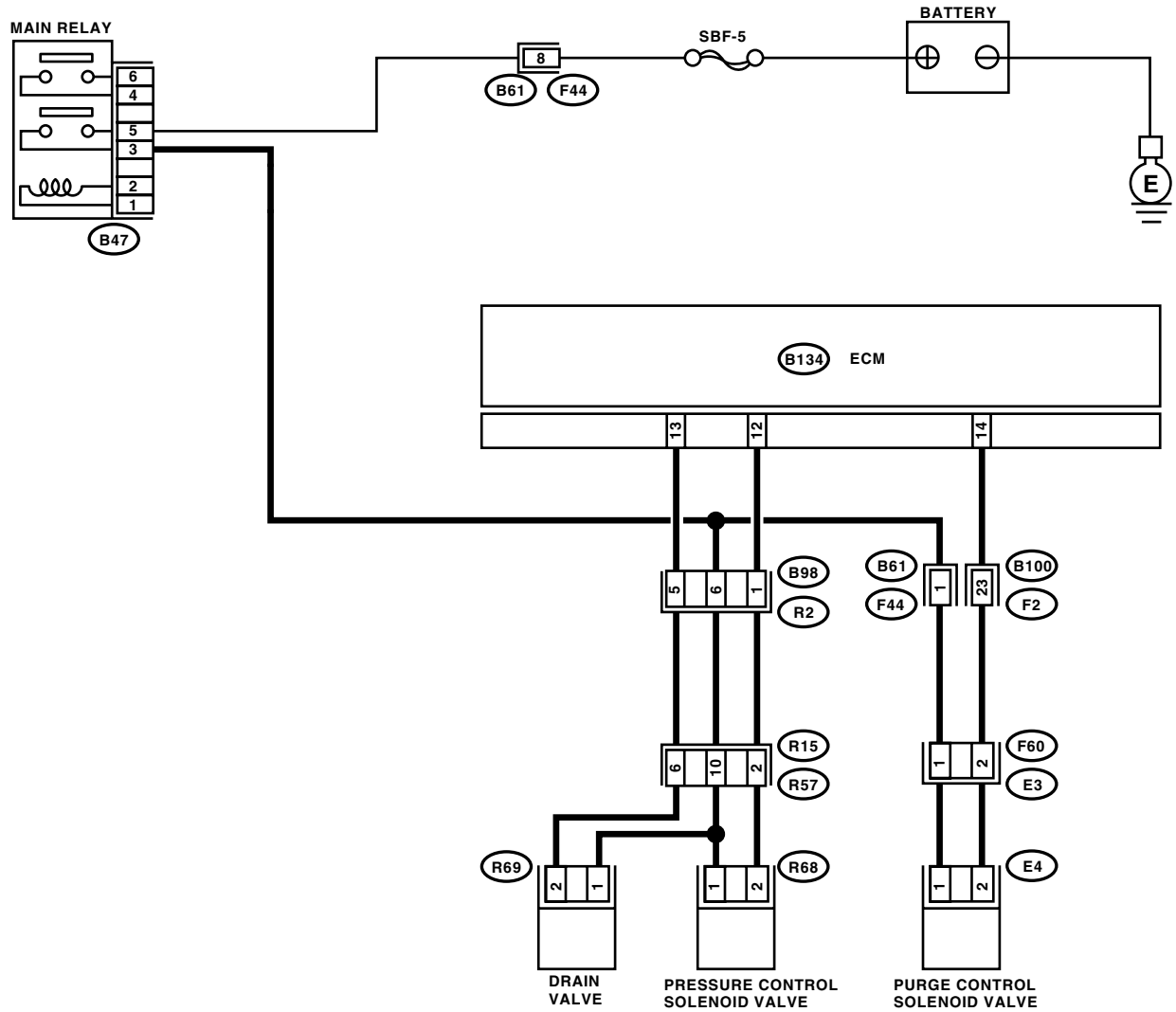

EN-01832

# DIAGNOSTIC PROCEDURE WITH DIAGNOSTIC TROUBLE CODE (DTC)

ENGINE (DIAGNOSTICS)

	Step	Check	Yes	No
1	<b>CHECK FOR OTHER DTC ON DISPLAY.</b>	Is any other DTC displayed?	Inspect the relevant DTC using "List of Diagnostic Trouble Code (DTC)". <Ref. to EN(STi)-66, List of Diagnostic Trouble Code (DTC).>	Go to step 2.
2	<b>CHECK FUEL FILLER CAP.</b> 1) Turn ignition switch to OFF. 2) Check the fuel filler cap. <b>NOTE:</b> The DTC is stored in memory if fuel filler cap is or was loose or if the cap chain was caught while tightening.	Is the fuel filler cap tightened securely?	Go to step 3.	Tighten fuel filler cap securely.
3	<b>CHECK FUEL FILLER CAP.</b>	Is the fuel filler cap SUBARU genuine?	Go to step 4.	Replace with a SUBARU genuine fuel filler cap.
4	<b>CHECK FUEL FILLER PIPE PACKING.</b>	Is there any damage to the seal between fuel filler cap and fuel filler pipe?	Repair or replace the fuel filler cap and fuel filler pipe. <Ref. to FU(STi)-49, Fuel Filler Pipe.>	Go to step 5.
5	<b>CHECK DRAIN VALVE.</b> 1) Connect the test mode connector. 2) Turn ignition switch to ON. 3) Operate the drain valve. <b>NOTE:</b> Drain valve operation can also be executed using Subaru Select Monitor. For the procedure, refer to "Compulsory Valve Operation Check Mode". <Ref. to EN(STi)-43, Compulsory Valve Operation Check Mode.>	Does the drain valve operate?	Go to step 6.	Replace the drain valve. <Ref. to EC(STi)-18, Drain Valve.>
6	<b>CHECK PURGE CONTROL SOLENOID VALVE.</b> Operate the purge control solenoid valve. <b>NOTE:</b> Purge control solenoid valve operation can also be executed using Subaru Select Monitor. For the procedure, refer to "Compulsory Valve Operation Check Mode". <Ref. to EN(STi)-43, Compulsory Valve Operation Check Mode.>	Does the purge control solenoid valve operate?	Go to step 7.	Replace the purge control solenoid valve. <Ref. to EC(STi)-6, Purge Control Solenoid Valve.>
7	<b>CHECK PRESSURE CONTROL SOLENOID VALVE.</b> Operate the pressure control solenoid valve. <b>NOTE:</b> Pressure control solenoid valve operation can also be executed using Subaru Select Monitor. For the procedure, refer to "Compulsory Valve Operation Check Mode". <Ref. to EN(STi)-43, Compulsory Valve Operation Check Mode.>	Does the pressure control solenoid valve operate?	Go to step 8.	Replace the pressure control solenoid valve. <Ref. to EC(STi)-6, Purge Control Solenoid Valve.>
8	<b>CHECK EVAPORATIVE EMISSION CONTROL SYSTEM LINE.</b> Turn ignition switch to OFF.	Is there a hole of more than 0.5 mm (0.020 in) dia. on evaporation line?	Repair or replace the evaporation line. <Ref. to FU(STi)-63, Fuel Delivery, Return and Evaporation Lines.>	Go to step 9.

# DIAGNOSTIC PROCEDURE WITH DIAGNOSTIC TROUBLE CODE (DTC)

ENGINE (DIAGNOSTICS)

Step	Check	Yes	No
<b>9</b> <b>CHECK CANISTER.</b>	Is the canister damaged or is there a hole of more than 0.5 mm (0.020 in) dia. in it?	Repair or replace the canister. <Ref. to EC(STi)-5, Canister.>	Go to step <b>10</b> .
<b>10</b> <b>CHECK FUEL TANK.</b> Remove the fuel tank. <Ref. to FU(H4DOTC)-52, Fuel Tank.>	Is the fuel tank damaged or is there a hole of more than 0.5 mm (0.020 in) dia. in it?	Repair or replace the fuel tank. <Ref. to FU(STi)-46, Fuel Tank.>	Go to step <b>11</b> .
<b>11</b> <b>CHECK ANY OTHER MECHANICAL TROUBLE IN EVAPORATIVE EMISSION CONTROL SYSTEM.</b>	Are there holes of more than 0.5 mm (0.020 in) dia., cracks, clogging, or disconnections, bend, misconnection of hoses or pipes in evaporative emission control system?	Repair or replace the hoses or pipes.	Contact with SOA Service Center. <b>NOTE:</b> Inspection by DTM is required, because probable cause is deterioration of multiple parts.

## DIAGNOSTIC PROCEDURE WITH DIAGNOSTIC TROUBLE CODE (DTC)

ENGINE (DIAGNOSTICS)

### **BH:DTC P0457 — EVAPORATIVE EMISSION CONTROL SYSTEM LEAK DETECTED (FUEL CAP LOOSE/OFF) —**

#### **• DTC DETECTING CONDITION:**

- Two consecutive driving cycles with fault
- GENERAL DESCRIPTION <Ref. to GD(STi)-154, DTC P0457 — EVAPORATIVE EMISSION CONTROL SYSTEM LEAK DETECTED (FUEL CAP LOOSE/OFF) —, Diagnostic Trouble Code (DTC) Detecting Criteria.>

#### **• TROUBLE SYMPTOM:**

- Fuel odor
- Fuel filler cap is loose or not installed.

#### **CAUTION:**

**After repair or replacement of faulty parts, conduct Clear Memory Mode <Ref. to EN(STi)-42, OPERATION, Clear Memory Mode.> and Inspection Mode <Ref. to EN(STi)-35, OPERATION, Inspection Mode.>.**

# DIAGNOSTIC PROCEDURE WITH DIAGNOSTIC TROUBLE CODE (DTC)

## ENGINE (DIAGNOSTICS)

• WIRING DIAGRAM:

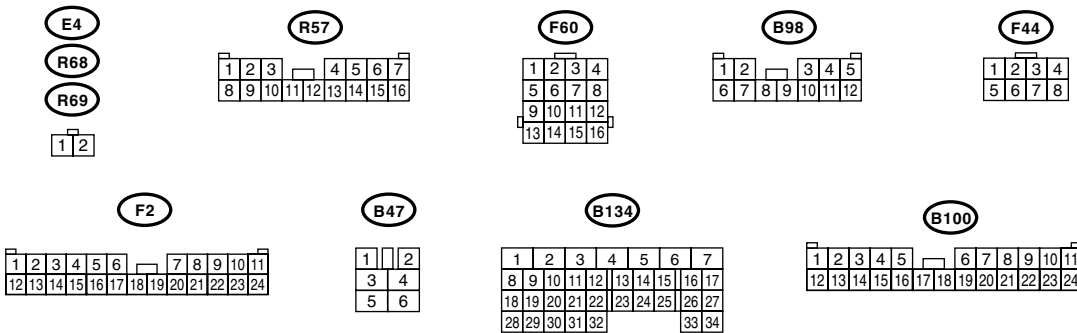
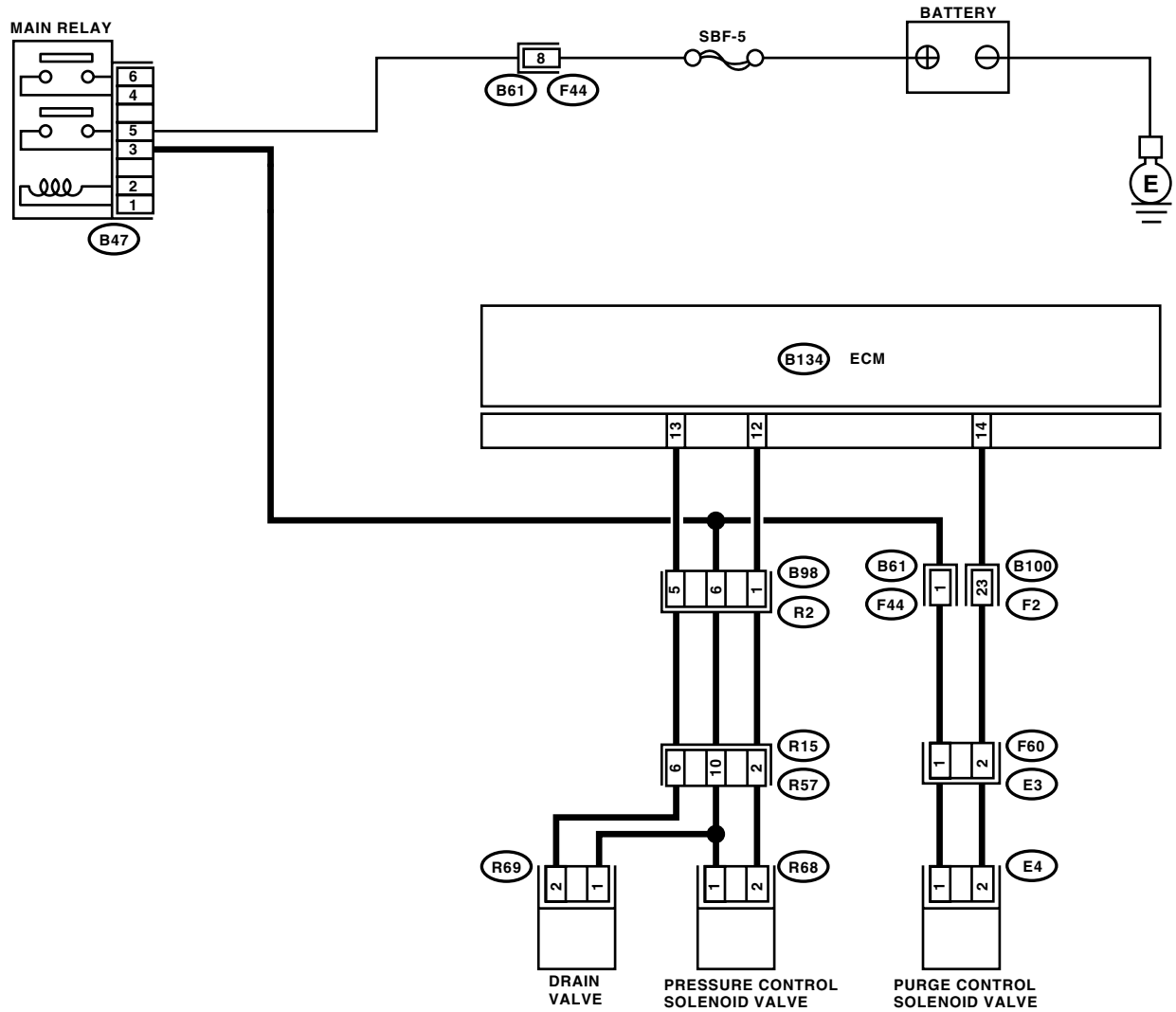

EN-01832

# DIAGNOSTIC PROCEDURE WITH DIAGNOSTIC TROUBLE CODE (DTC)

ENGINE (DIAGNOSTICS)

	Step	Check	Yes	No
1	<b>CHECK FOR OTHER DTC ON DISPLAY.</b>	Is any other DTC displayed?	Inspect the relevant DTC using "List of Diagnostic Trouble Code (DTC)". <Ref. to EN(STi)-66, List of Diagnostic Trouble Code (DTC).>	Go to step 2.
2	<b>CHECK FUEL FILLER CAP.</b> 1) Turn ignition switch to OFF. 2) Check the fuel filler cap. <b>NOTE:</b> The DTC is stored in memory if fuel filler cap is or was loose or if the cap chain was caught while tightening.	Is the fuel filler cap tightened securely?	Go to step 3.	Tighten fuel filler cap securely.
3	<b>CHECK FUEL FILLER CAP.</b>	Is the fuel filler cap SUBARU genuine?	Go to step 4.	Replace with a SUBARU genuine fuel filler cap.
4	<b>CHECK FUEL FILLER PIPE PACKING.</b>	Is there any damage to the seal between fuel filler cap and fuel filler pipe?	Repair or replace the fuel filler cap and fuel filler pipe. <Ref. to FU(STi)-49, Fuel Filler Pipe.>	Go to step 5.
5	<b>CHECK DRAIN VALVE.</b> 1) Connect the test mode connector. 2) Turn ignition switch to ON. 3) Operate the drain valve. <b>NOTE:</b> Drain valve operation can also be executed using Subaru Select Monitor. For the procedure, refer to "Compulsory Valve Operation Check Mode". <Ref. to EN(STi)-43, Compulsory Valve Operation Check Mode.>	Does the drain valve operate?	Go to step 6.	Replace the drain valve. <Ref. to EC(STi)-18, Drain Valve.>
6	<b>CHECK PURGE CONTROL SOLENOID VALVE.</b> Operate the purge control solenoid valve. <b>NOTE:</b> Purge control solenoid valve operation can also be executed using Subaru Select Monitor. For the procedure, refer to "Compulsory Valve Operation Check Mode". <Ref. to EN(STi)-66, List of Diagnostic Trouble Code (DTC).>	Does the purge control solenoid valve operate?	Go to step 7.	Replace the purge control solenoid valve. <Ref. to EC(STi)-6, Purge Control Solenoid Valve.>
7	<b>CHECK PRESSURE CONTROL SOLENOID VALVE.</b> Operate the pressure control solenoid valve. <b>NOTE:</b> Pressure control solenoid valve operation can also be executed using Subaru Select Monitor. For the procedure, refer to "Compulsory Valve Operation Check Mode". <Ref. to EN(STi)-43, Compulsory Valve Operation Check Mode.>	Does the pressure control solenoid valve operate?	Go to step 8.	Replace the pressure control solenoid valve. <Ref. to EC(STi)-6, Purge Control Solenoid Valve.>
8	<b>CHECK CANISTER.</b>	Is the canister damaged?	Repair or replace the canister. <Ref. to EC(STi)-5, Canister.>	Go to step 9.

# DIAGNOSTIC PROCEDURE WITH DIAGNOSTIC TROUBLE CODE (DTC)

ENGINE (DIAGNOSTICS)

Step	Check	Yes	No
<b>9</b> <b>CHECK FUEL TANK.</b> Remove the fuel tank. <Ref. to FU(STi)-46, Fuel Tank.>	Is the fuel tank damaged?	Repair or replace the fuel tank. <Ref. to FU(STi)-46, Fuel Tank.>	Go to step <b>10</b> .
<b>10</b> <b>CHECK ANY OTHER MECHANICAL TROUBLE IN EVAPORATIVE EMISSION CONTROL SYSTEM.</b>	Are there holes of more than 0.5 mm (0.020 in) dia., cracks, clogging, or disconnections, misconnection of hoses or pipes in evaporative emission control system?	Repair or replace the hoses or pipes.	Contact with SOA Service Center. <b>NOTE:</b> Inspection by DTM is required, because probable cause is deterioration of multiple parts.



# DIAGNOSTIC PROCEDURE WITH DIAGNOSTIC TROUBLE CODE (DTC)

ENGINE (DIAGNOSTICS)

## BI: DTC P0458 — EVAPORATIVE EMISSION CONTROL SYSTEM PURGE CONTROL VALVE CIRCUIT LOW —

### • DTC DETECTING CONDITION:

- Two consecutive driving cycles with fault
- GENERAL DESCRIPTION <Ref. to GD(STi)-155, DTC P0458 — EVAPORATIVE EMISSION CONTROL SYSTEM PURGE CONTROL VALVE CIRCUIT LOW —, Diagnostic Trouble Code (DTC) Detecting Criteria.>

### • TROUBLE SYMPTOM:

- Erroneous idling

### CAUTION:

After repair or replacement of faulty parts, conduct Clear Memory Mode <Ref. to EN(STi)-42, OPERATION, Clear Memory Mode.> and Inspection Mode <Ref. to EN(STi)-35, OPERATION, Inspection Mode.>.

### • WIRING DIAGRAM:

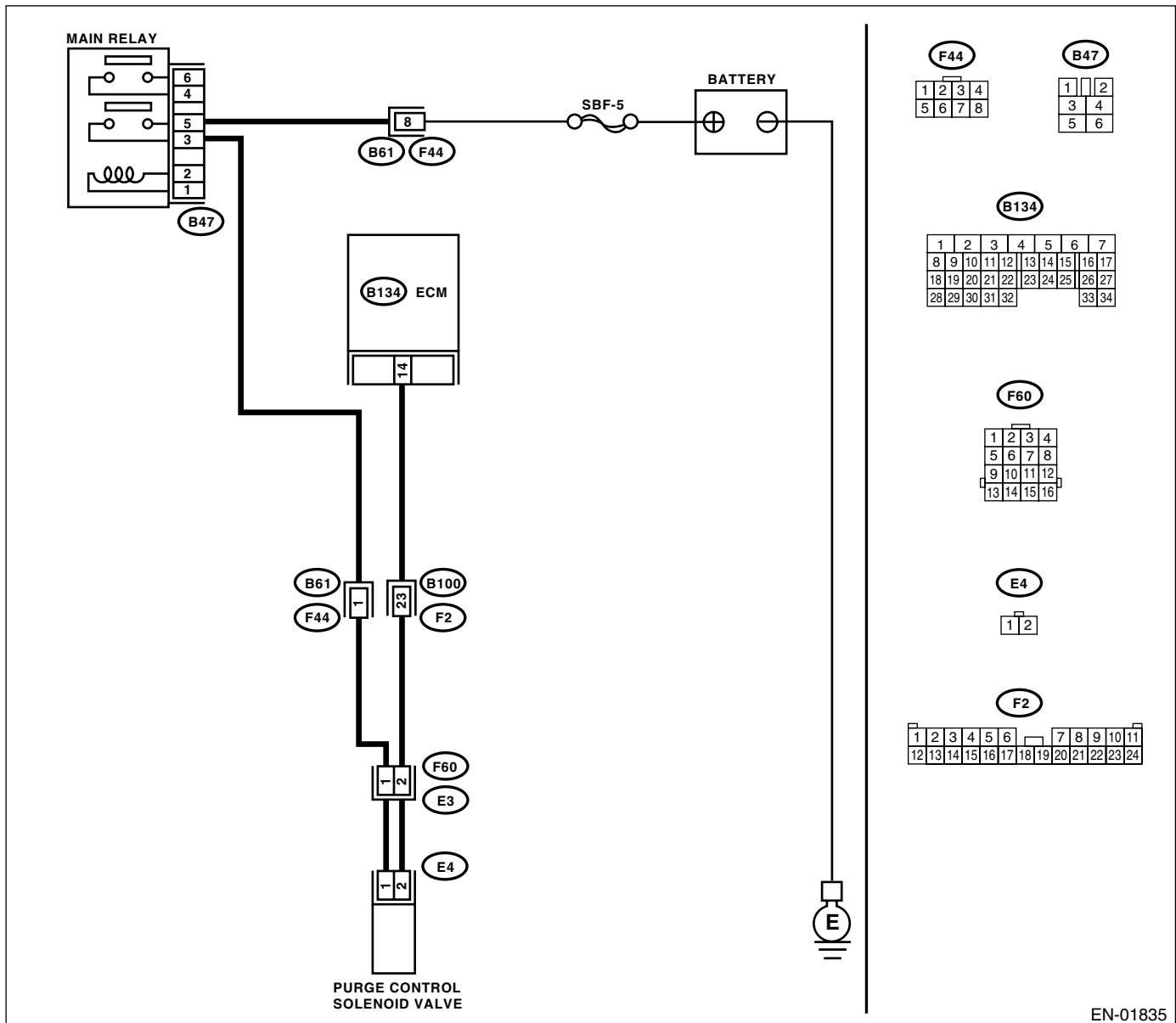

# DIAGNOSTIC PROCEDURE WITH DIAGNOSTIC TROUBLE CODE (DTC)

## ENGINE (DIAGNOSTICS)

Step	Check	Yes	No
<b>1 CHECK OUTPUT SIGNAL FROM ECM.</b> 1) Turn the ignition switch to ON. 2) Measure the voltage between ECM and chassis ground. <i><b>Connector &amp; terminal</b></i> <i><b>(B134) No. 14 (+) — Chassis ground (-):</b></i>	Is the voltage more than 10 V?	Even if malfunction indicator light lights up, the circuit has returned to a normal condition at this time.	Go to step 2.
<b>2 CHECK HARNESS BETWEEN PURGE CONTROL SOLENOID VALVE AND ECM CONNECTOR.</b> 1) Turn the ignition switch to OFF. 2) Disconnect the connectors from purge control solenoid valve and ECM. 3) Measure the resistance of harness between purge control solenoid valve connector and engine ground. <i><b>Connector &amp; terminal</b></i> <i><b>(E4) No. 2 — Engine ground:</b></i>	Is the resistance more than 1 M $\Omega$ ?	Go to step 3.	Repair the ground short circuit in harness between ECM and purge control solenoid valve connector.
<b>3 CHECK HARNESS BETWEEN PURGE CONTROL SOLENOID VALVE AND ECM CONNECTOR.</b> Measure the resistance of harness between ECM and purge control solenoid valve of harness connector. <i><b>Connector &amp; terminal</b></i> <i><b>(B134) No. 14 — (E4) No. 2:</b></i>	Is the resistance less than 1 $\Omega$ ?	Go to step 4.	Repair the open circuit in harness between ECM and purge control solenoid valve connector.  NOTE: In this case, repair the following: <ul style="list-style-type: none"> <li>• Open circuit in harness between ECM and purge control solenoid valve connector</li> <li>• Poor contact in coupling connector</li> </ul>
<b>4 CHECK PURGE CONTROL SOLENOID VALVE.</b> 1) Remove the purge control solenoid valve. 2) Measure the resistance between purge control solenoid valve terminals. <i><b>Terminals</b></i> <i><b>No. 1 — No. 2:</b></i>	Is the resistance 10 — 100 $\Omega$ ?	Go to step 5.	Replace the purge control solenoid valve. <Ref. to EC(STi)-6, Purge Control Solenoid Valve.>
<b>5 CHECK POWER SUPPLY TO PURGE CONTROL SOLENOID VALVE.</b> 1) Turn the ignition switch to ON. 2) Measure the voltage between purge control solenoid valve and engine ground. <i><b>Connector &amp; terminal</b></i> <i><b>(E4) No. 1 (+) — Engine ground (-):</b></i>	Is the voltage more than 10 V?	Go to step 6.	Repair the open circuit in harness between main relay and purge control solenoid valve connector.
<b>6 CHECK POOR CONTACT.</b> Check poor contact in purge control solenoid valve connector.	Is there poor contact in purge control solenoid valve connector?	Repair the poor contact in purge control solenoid valve connector.	Contact your SOA Service Center.  NOTE: Inspection by DTM is required, because probable cause is deterioration of multiple parts.

# DIAGNOSTIC PROCEDURE WITH DIAGNOSTIC TROUBLE CODE (DTC)

ENGINE (DIAGNOSTICS)

## BJ:DTC P0459 — EVAPORATIVE EMISSION CONTROL SYSTEM PURGE CONTROL VALVE CIRCUIT HIGH —

### • DTC DETECTING CONDITION:

- Two consecutive driving cycles with fault
- GENERAL DESCRIPTION <Ref. to GD(STi)-157, DTC P0459 — EVAPORATIVE EMISSION CONTROL SYSTEM PURGE CONTROL VALVE CIRCUIT HIGH —, Diagnostic Trouble Code (DTC) Detecting Criteria.>

### • TROUBLE SYMPTOM:

- Erroneous idling

### CAUTION:

After repair or replacement of faulty parts, conduct Clear Memory Mode <Ref. to EN(STi)-42, OPERATION, Clear Memory Mode.> and Inspection Mode <Ref. to EN(STi)-35, OPERATION, Inspection Mode.>.

### • WIRING DIAGRAM:

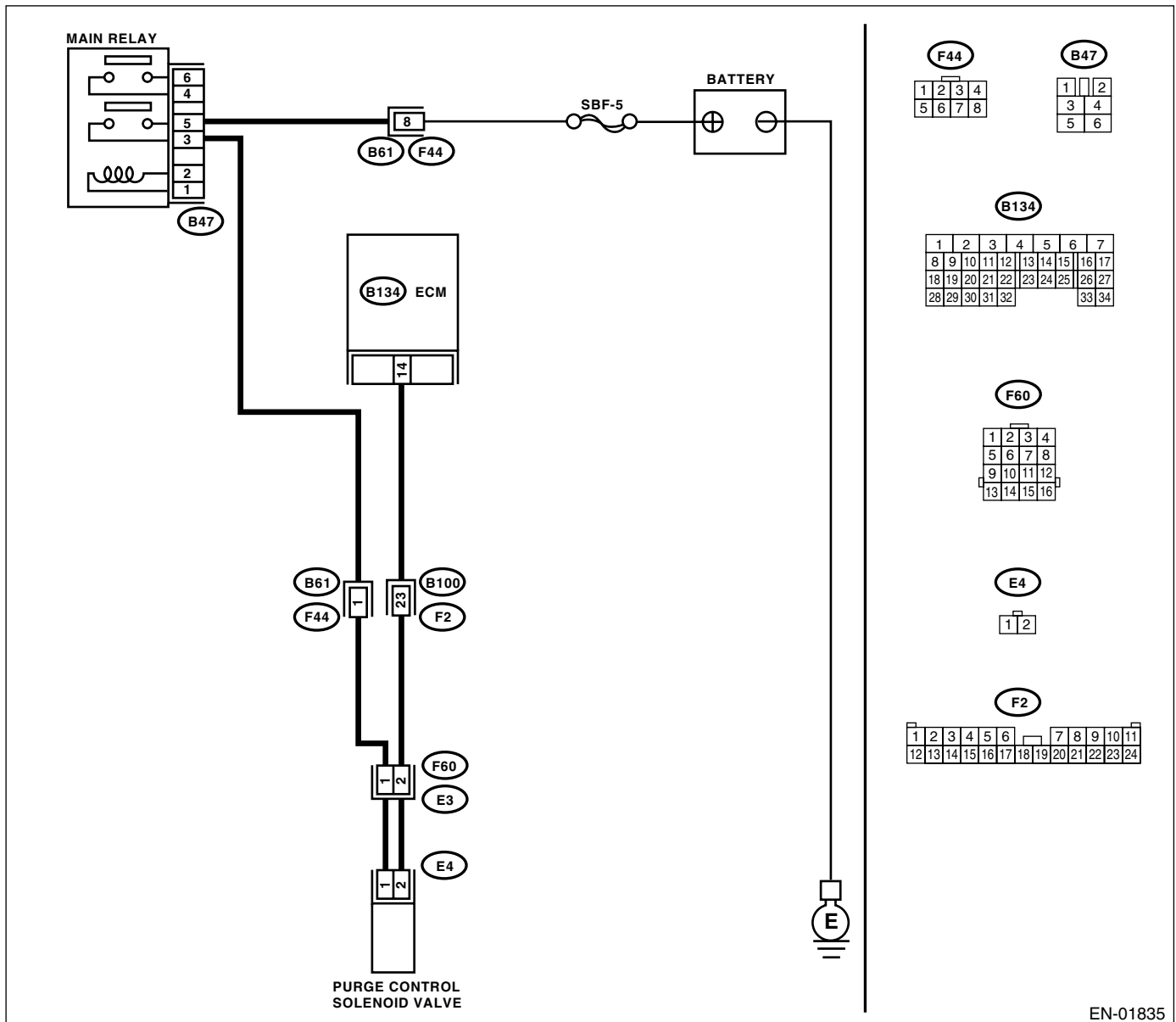

EN-01835

# DIAGNOSTIC PROCEDURE WITH DIAGNOSTIC TROUBLE CODE (DTC)

## ENGINE (DIAGNOSTICS)

Step	Check	Yes	No
<p><b>1 CHECK OUTPUT SIGNAL FROM ECM.</b>                      1) Turn the ignition switch to OFF.                      2) Connect the test mode connector at the lower portion of instrument panel (on the driver's side).                      3) Turn the ignition switch to ON.                      4) While operating the purge control solenoid valve, measure the voltage between ECM and chassis ground.</p> <p><b>NOTE:</b>                      Purge control solenoid valve operation can be executed using the Subaru Select Monitor. For procedure, refer to "Compulsory Valve Operation Check Mode". &lt;Ref. to EN(STi)-43, Compulsory Valve Operation Check Mode.&gt;</p> <p><b>Connector &amp; terminal</b>  <b>(B134) No. 14 (+) — Chassis ground (-):</b></p>	Is the voltage 0 — 13 V?	Go to step 2.	Even if malfunction indicator light lights up, the circuit has returned to a normal condition at this time. In this case, repair the poor contact in ECM connector.
<p><b>2 CHECK OUTPUT SIGNAL FROM ECM.</b>                      1) Turn the ignition switch to ON.                      2) Measure the voltage between ECM and chassis ground.</p> <p><b>Connector &amp; terminal</b>  <b>(B134) No. 14 (+) — Chassis ground (-):</b></p>	Is the voltage more than 10 V?	Go to step 4.	Go to step 3.
<p><b>3 CHECK POOR CONTACT.</b>                      Check the poor contact in ECM connector.</p>	Is there poor contact in ECM connector?	Repair the poor contact in ECM connector.	Replace the ECM. <Ref. to FU(STi)-41, Engine Control Module (ECM).>
<p><b>4 CHECK HARNESS BETWEEN PURGE CONTROL SOLENOID VALVE AND ECM CONNECTOR.</b>                      1) Turn the ignition switch to OFF.                      2) Disconnect the connector from purge control solenoid valve.                      3) Turn the ignition switch to ON.                      4) Measure the voltage between ECM and chassis ground.</p> <p><b>Connector &amp; terminal</b>  <b>(B134) No. 14 (+) — Chassis ground (-):</b></p>	Is the voltage more than 10 V?	Repair the battery short circuit in harness between ECM and purge control solenoid valve connector. After repair, replace the ECM. <Ref. to FU(STi)-41, Engine Control Module (ECM).>	Go to step 5.
<p><b>5 CHECK PURGE CONTROL SOLENOID VALVE.</b>                      1) Turn the ignition switch to OFF.                      2) Measure the resistance between purge control solenoid valve terminals.</p> <p><b>Terminals</b>  <b>No. 1 — No. 2:</b></p>	Is the resistance less than 1 $\Omega$ ?	Replace the purge control solenoid valve <Ref. to EC(STi)-6, Purge Control Solenoid Valve.> and ECM <Ref. to FU(STi)-41, Engine Control Module (ECM).>	Go to step 6.
<p><b>6 CHECK POOR CONTACT.</b>                      Check poor contact in ECM connector.</p>	Is there poor contact in ECM connector?	Repair the poor contact in ECM connector.	Replace the ECM. <Ref. to FU(STi)-41, Engine Control Module (ECM).>

## DIAGNOSTIC PROCEDURE WITH DIAGNOSTIC TROUBLE CODE (DTC)

ENGINE (DIAGNOSTICS)

### **BK:DTC P0461 — FUEL LEVEL SENSOR CIRCUIT RANGE/PERFORMANCE —**

• **DTC DETECTING CONDITION:**

- Two consecutive driving cycles with fault
- GENERAL DESCRIPTION <Ref. to GD(STi)-159, DTC P0461 — FUEL LEVEL SENSOR CIRCUIT RANGE/PERFORMANCE —, Diagnostic Trouble Code (DTC) Detecting Criteria.>

**CAUTION:**

After repair or replacement of faulty parts, conduct Clear Memory Mode <Ref. to EN(STi)-42, OPERATION, Clear Memory Mode.> and Inspection Mode <Ref. to EN(STi)-35, OPERATION, Inspection Mode.>.

# DIAGNOSTIC PROCEDURE WITH DIAGNOSTIC TROUBLE CODE (DTC)

## ENGINE (DIAGNOSTICS)

### • WIRING DIAGRAM:

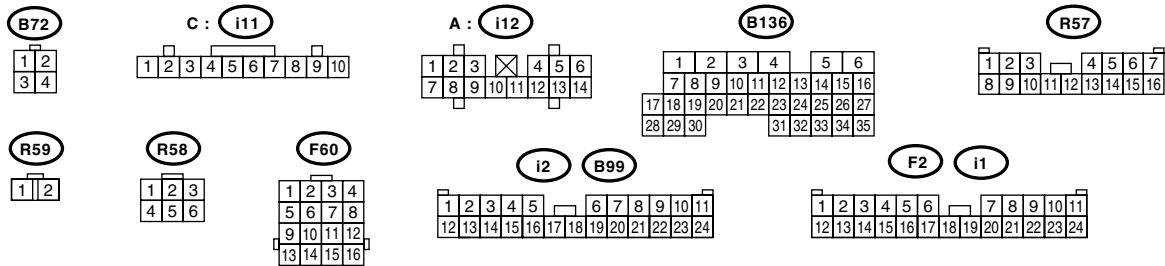
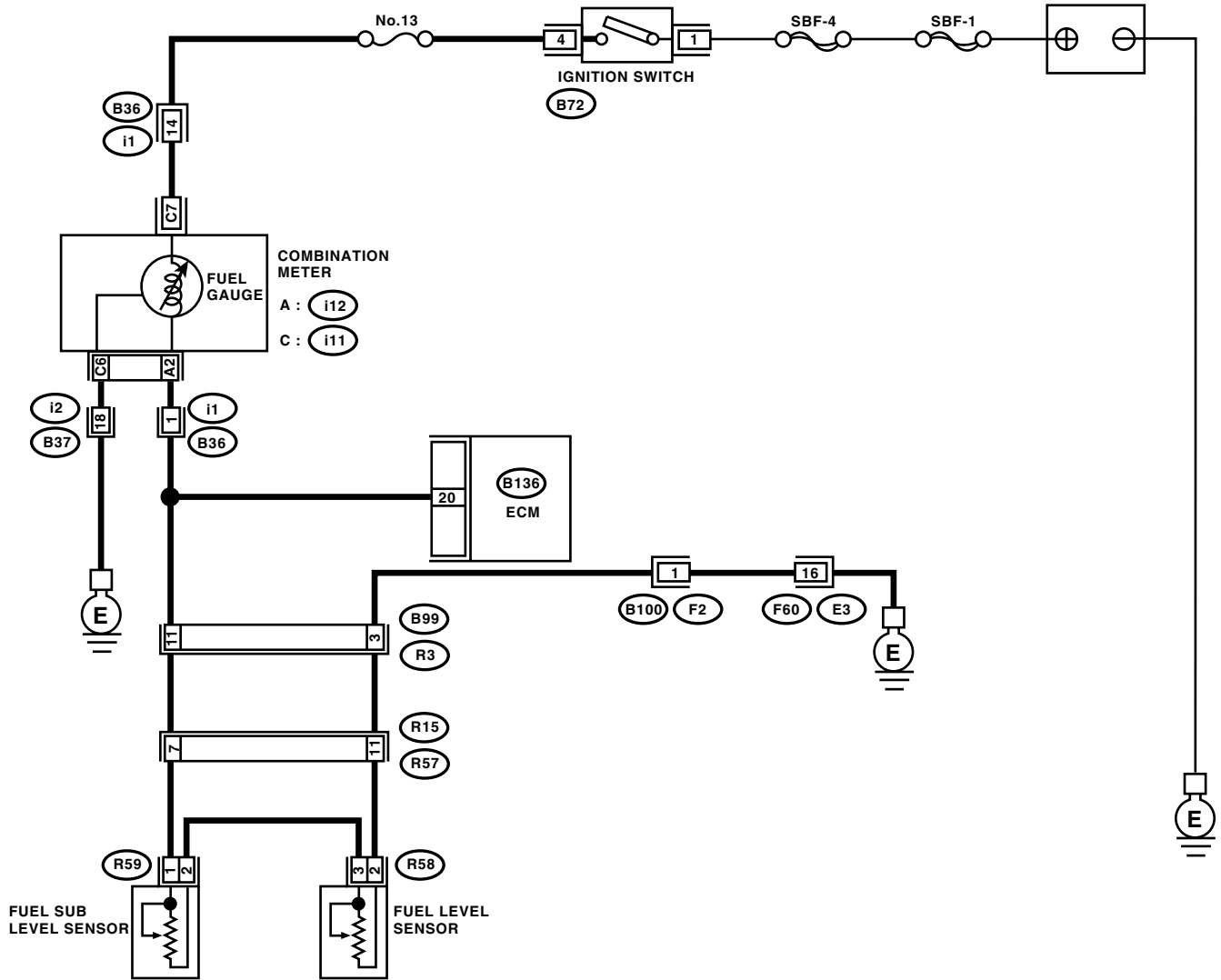

EN-01836

# DIAGNOSTIC PROCEDURE WITH DIAGNOSTIC TROUBLE CODE (DTC)

ENGINE (DIAGNOSTICS)

	Step	Check	Yes	No
1	<b>CHECK ANY OTHER DTC ON DISPLAY.</b>	Is any other DTC displayed?	Inspect the relevant DTC using "List of Diagnostic Trouble Code (DTC)". <Ref. to EN(STi)-66, List of Diagnostic Trouble Code (DTC).>  NOTE: In this case, it is not necessary to inspect DTC P0461.	Replace the fuel level sensor. <Ref. to FU(STi)-57, Fuel Level Sensor.> and fuel sub level sensor <Ref. to FU(STi)-58, Fuel Sub Level Sensor.>

## DIAGNOSTIC PROCEDURE WITH DIAGNOSTIC TROUBLE CODE (DTC)

ENGINE (DIAGNOSTICS)

---

### **BL:DTC P0462 — FUEL LEVEL SENSOR CIRCUIT LOW INPUT —**

• **DTC DETECTING CONDITION:**

- Two consecutive driving cycles with fault
- GENERAL DESCRIPTION <Ref. to GD(STi)-161, DTC P0462 — FUEL LEVEL SENSOR CIRCUIT LOW INPUT —, Diagnostic Trouble Code (DTC) Detecting Criteria.>

**CAUTION:**

After repair or replacement of faulty parts, conduct Clear Memory Mode <Ref. to EN(STi)-42, OPERATION, Clear Memory Mode.> and Inspection Mode <Ref. to EN(STi)-35, OPERATION, Inspection Mode.>.



# DIAGNOSTIC PROCEDURE WITH DIAGNOSTIC TROUBLE CODE (DTC) ENGINE (DIAGNOSTICS)

• WIRING DIAGRAM:

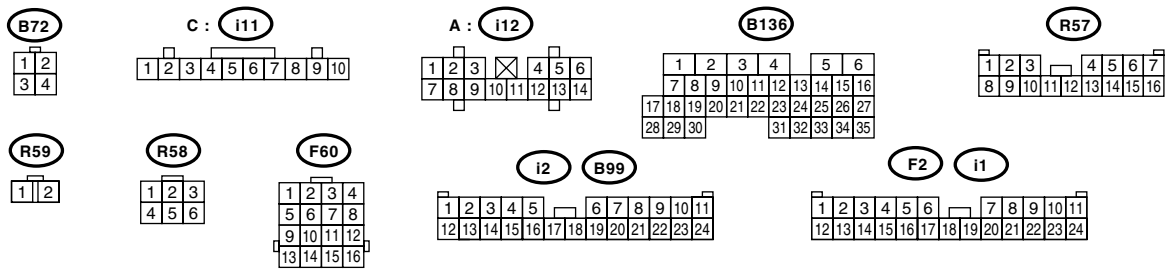
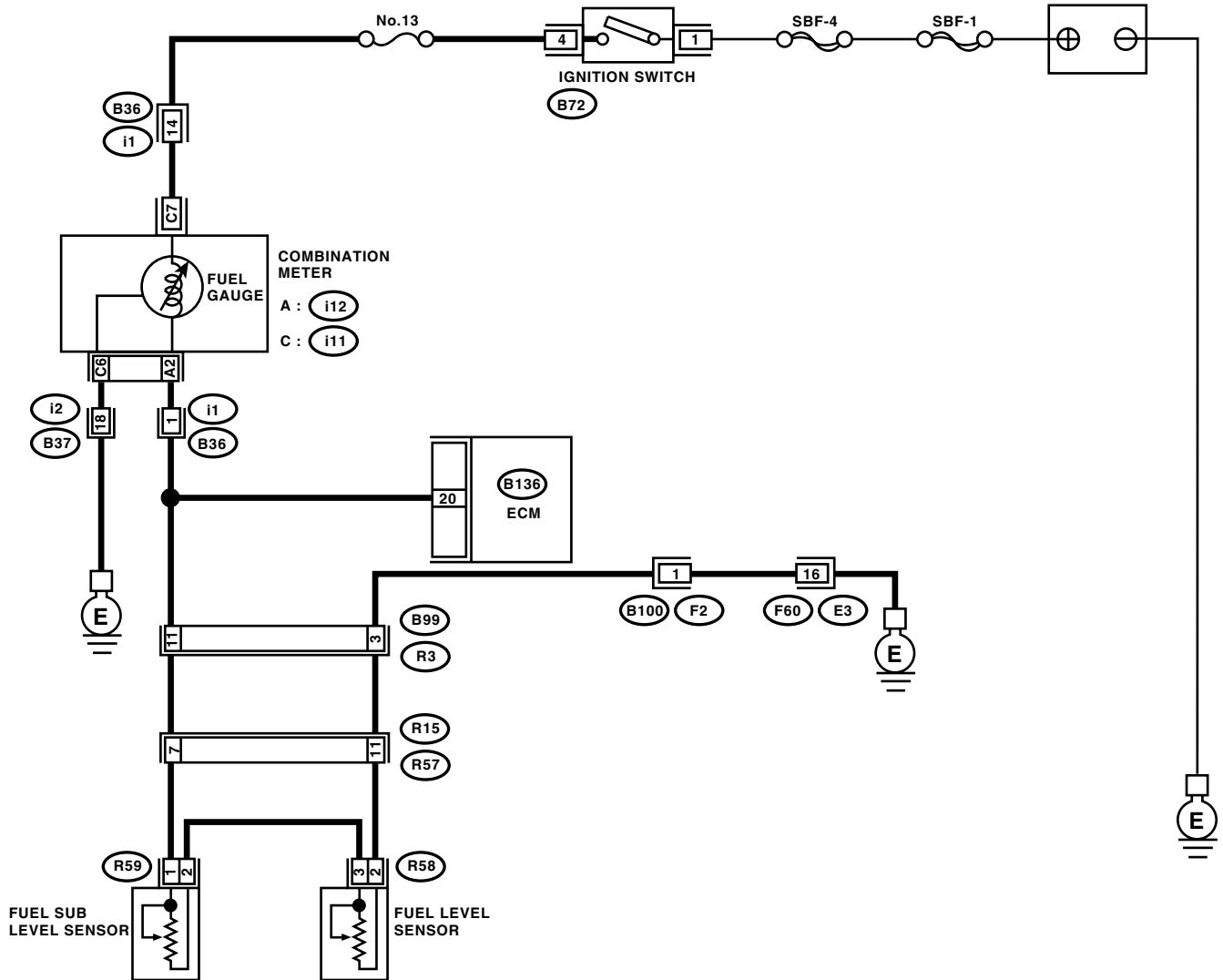

EN-01836

# DIAGNOSTIC PROCEDURE WITH DIAGNOSTIC TROUBLE CODE (DTC)

## ENGINE (DIAGNOSTICS)

Step	Check	Yes	No
<b>1 CHECK SPEEDOMETER AND TACHOMETER OPERATION IN COMBINATION METER.</b>	Does the speedometer and tachometer operate normally?	Go to step 2.	Repair or replace the combination meter. <Ref. to IDI-3, Combination Meter System.>
<b>2 CHECK INPUT SIGNAL FOR ECM.</b> 1) Turn the ignition switch to ON. (engine OFF) 2) Measure the voltage between ECM connector and chassis ground. <b>Connector &amp; terminal</b> <b>(B136) No. 20 (+) — Chassis ground (-):</b>	Is the voltage less than 0.12 V?	Go to step 4.	Go to step 3.
<b>3 CHECK INPUT SIGNAL FOR ECM. (USING SUBARU SELECT MONITOR)</b> Read the data of fuel level sensor signal using Subaru Select Monitor.  NOTE: • Subaru Select Monitor For detailed operation procedure, refer to the "READ CURRENT DATA FOR ENGINE". <Ref. to EN(STi)-28, Subaru Select Monitor.>	Does the voltage change, while shaking the ECM harness and connector?	Repair the poor contact in ECM connector.	Even if malfunction indicator light lights up, the circuit has returned to a normal condition at this time. A temporary poor contact of the connector may be the cause.  NOTE: In this case, repair the following: • Poor contact in combination meter connector • Poor contact in ECM connector • Poor contact in coupling connectors
<b>4 CHECK INPUT VOLTAGE OF ECM.</b> 1) Turn the ignition switch to OFF. 2) Separate the fuel tank cord connector (R57) and rear wiring harness connector (R15). 3) Turn the ignition switch to ON. 4) Measure the voltage of harness between ECM connector and chassis ground. <b>Connector &amp; terminal</b> <b>(B136) No. 20 (+) — Chassis ground (-):</b>	Is the voltage more than 0.12 V?	Go to step 5.	Go to step 6.
<b>5 CHECK HARNESS BETWEEN ECM AND COMBINATION METER.</b> 1) Turn the ignition switch to OFF. 2) Disconnect the connector from connector (i11), (i12) and ECM connector. 3) Measure the resistance between ECM and chassis ground. <b>Connector &amp; terminal</b> <b>(B136) No. 20 — Chassis ground:</b>	Is the resistance more than 1 MΩ?	Go to step 7.	Repair the ground short circuit in harness between ECM and combination meter connector.

# DIAGNOSTIC PROCEDURE WITH DIAGNOSTIC TROUBLE CODE (DTC)

ENGINE (DIAGNOSTICS)

Step	Check	Yes	No
<p><b>6 CHECK HARNESS BETWEEN ECM AND COMBINATION METER.</b> Measure the resistance between ECM and combination meter connector. <b>Connector &amp; terminal</b> <b>(B136) No. 20 — (i12) No. 2:</b></p>	<p>Is the resistance less than 10 <math>\Omega</math>?</p>	<p>Repair or replace the combination meter. &lt;Ref. to IDI-3, Combination Meter System.&gt;</p>	<p>Repair the open circuit between ECM and combination meter connector. <b>NOTE:</b> In this case, repair the following: Poor contact in coupling connector</p>
<p><b>7 CHECK FUEL TANK CORD.</b> 1)Turn the ignition switch to OFF. 2)Disconnect the connector from fuel sub level sensor. 3)Measure the resistance between fuel sub level sensor and chassis ground. <b>Connector &amp; terminal</b> <b>(R59) No. 1 — Chassis ground:</b></p>	<p>Is the resistance more than 1 M<math>\Omega</math>?</p>	<p>Go to step 8.</p>	<p>Repair the ground short circuit in fuel tank cord.</p>
<p><b>8 CHECK FUEL TANK CORD.</b> 1)Disconnect the connector from fuel pump assembly. 2)Measure the resistance between fuel pump assembly and chassis ground. <b>Connector &amp; terminal</b> <b>(R59) No. 2 — Chassis ground:</b></p>	<p>Is the resistance more than 1 M<math>\Omega</math>?</p>	<p>Go to step 9.</p>	<p>Repair the ground short circuit in fuel tank cord.</p>
<p><b>9 CHECK FUEL LEVEL SENSOR.</b> 1)Remove the fuel pump assembly. &lt;Ref. to FU(STi)-54, Fuel Pump.&gt; 2)Measure the resistance between fuel level sensor and terminals with its float set to the full position. <b>Terminals</b> <b>No. 2 — No. 3:</b></p>	<p>Is the resistance 0.5 — 2.5 <math>\Omega</math>?</p>	<p>Go to step 10.</p>	<p>Replace the fuel level sensor.</p>
<p><b>10 CHECK FUEL SUB LEVEL SENSOR.</b> 1)Remove the fuel sub level sensor. &lt;Ref. to FU(STi)-58, Fuel Sub Level Sensor.&gt; 2)Measure the resistance between fuel sub level sensor and terminals with its float set to the full position. <b>Terminals</b> <b>No. 1 — No. 2:</b></p>	<p>Is the resistance 0.5 — 2.5 <math>\Omega</math>?</p>	<p>Repair the poor contact in harness between ECM and combination meter connector.</p>	<p>Replace the fuel sub level sensor.</p>

## DIAGNOSTIC PROCEDURE WITH DIAGNOSTIC TROUBLE CODE (DTC)

ENGINE (DIAGNOSTICS)

---

### **BM:DTC P0463 — FUEL LEVEL SENSOR CIRCUIT HIGH INPUT —**

• **DTC DETECTING CONDITION:**

- Two consecutive driving cycles with fault
- GENERAL DESCRIPTION <Ref. to GD(STi)-163, DTC P0463 — FUEL LEVEL SENSOR CIRCUIT HIGH INPUT —, Diagnostic Trouble Code (DTC) Detecting Criteria.>

**CAUTION:**

After repair or replacement of faulty parts, conduct Clear Memory Mode <Ref. to EN(STi)-42, OPERATION, Clear Memory Mode.> and Inspection Mode <Ref. to EN(STi)-35, OPERATION, Inspection Mode.>.

# DIAGNOSTIC PROCEDURE WITH DIAGNOSTIC TROUBLE CODE (DTC) ENGINE (DIAGNOSTICS)

• WIRING DIAGRAM:

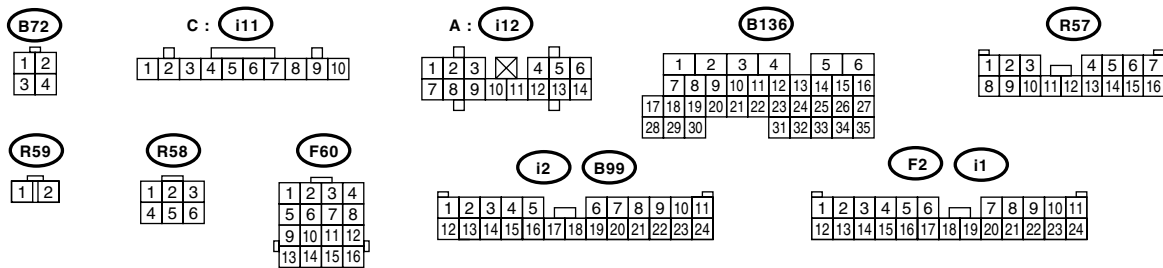
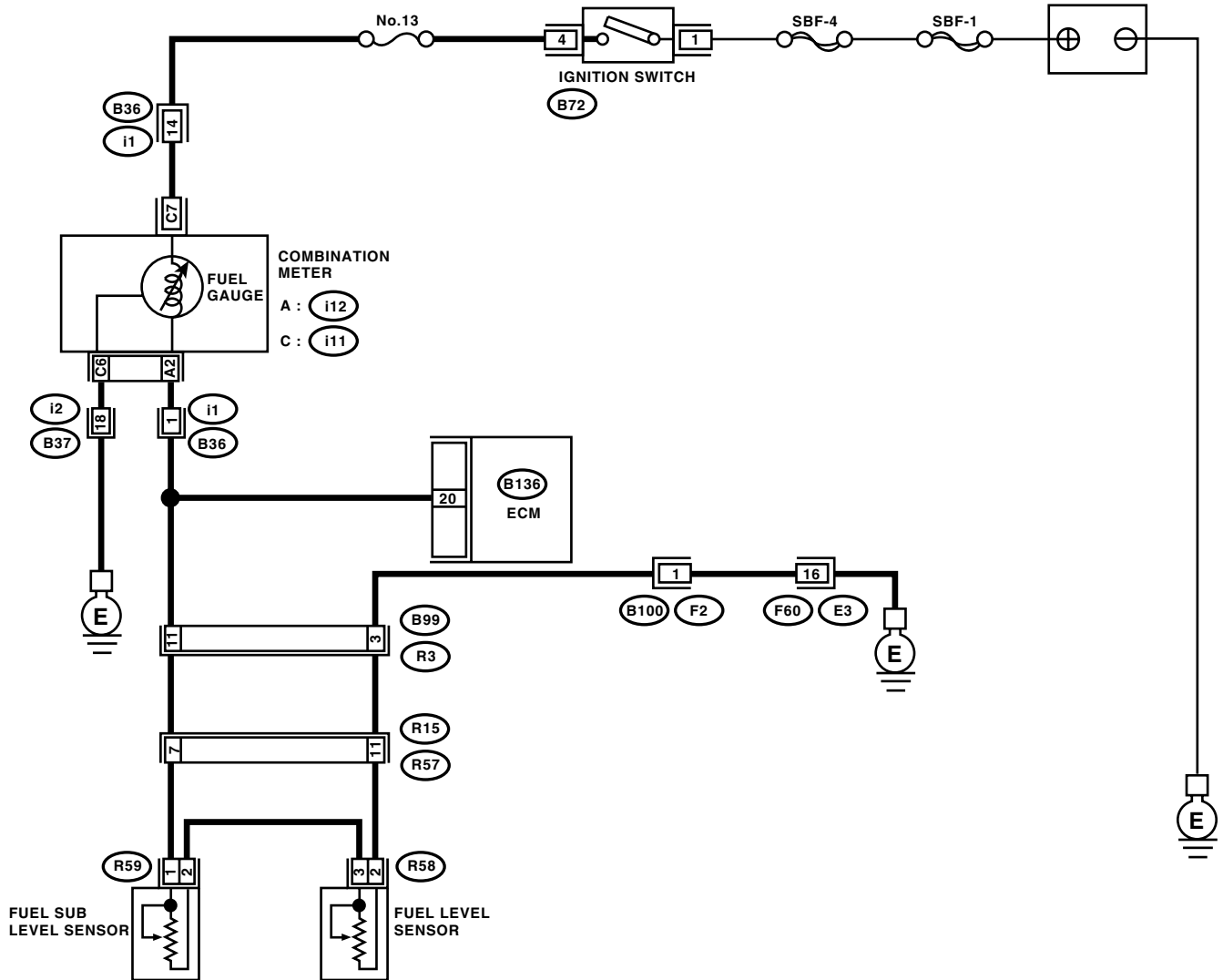

EN-01836

# DIAGNOSTIC PROCEDURE WITH DIAGNOSTIC TROUBLE CODE (DTC)

ENGINE (DIAGNOSTICS)

Step	Check	Yes	No
<b>1 CHECK SPEEDOMETER AND TACHOMETER OPERATION IN COMBINATION METER.</b>	Does the speedometer and tachometer operate normally?	Go to step 2.	Repair or replace the combination meter. <Ref. to IDI-3, Combination Meter System.>
<b>2 CHECK INPUT SIGNAL FOR ECM.</b> 1) Turn the ignition switch to ON. (engine OFF) 2) Measure the voltage between ECM connector and chassis ground. <b>Connector &amp; terminal</b> <b>(B136) No. 20 (+) — Chassis ground (-):</b>	Is the voltage more than 4.75 V?	Go to step 3.	Even if malfunction indicator light lights up, the circuit has returned to a normal condition at this time. A temporary poor contact of the connector may be the cause.  <b>NOTE:</b> In this case, repair the following: <ul style="list-style-type: none"> <li>• Poor contact in fuel pump connector</li> <li>• Poor contact in coupling connector</li> </ul>
<b>3 CHECK INPUT VOLTAGE OF ECM.</b> 1) Turn the ignition switch to OFF. 2) Disconnect the combination meter connector (i11) and ECM connector. 3) Turn the ignition switch to ON. 4) Measure the voltage of harness between ECM and chassis ground. <b>Connector &amp; terminal</b> <b>(B136) No. 20 (+) — Chassis ground (-):</b>	Is the voltage more than 4.75 V?	Go to step 4.	Repair the battery short circuit between ECM and combination meter connector.
<b>4 CHECK HARNESS BETWEEN ECM AND FUEL TANK CORD.</b> 1) Turn the ignition switch to OFF. 2) Separate the fuel tank cord connector (R57) and rear wiring harness connector (R15). 3) Measure the resistance between ECM and fuel tank cord. <b>Connector &amp; terminal</b> <b>(B136) No. 20 — (R15) No. 7:</b>	Is the resistance less than 5 $\Omega$ ?	Go to step 5.	Repair the open circuit between ECM and fuel tank cord.
<b>5 CHECK HARNESS BETWEEN FUEL TANK CORD AND CHASSIS GROUND.</b> Measure the resistance between fuel tank cord and chassis ground. <b>Connector &amp; terminal</b> <b>(R15) No. 11 — Chassis ground:</b>	Is the resistance less than 5 $\Omega$ ?	Go to step 6.	Repair the open circuit between fuel tank cord and chassis ground.  <b>NOTE:</b> In this case, repair the following: Poor contact in coupling connectors
<b>6 CHECK FUEL TANK CORD.</b> 1) Disconnect the connector from fuel level sensor. 2) Measure the resistance between fuel level sensor and coupling connector. <b>Connector &amp; terminal</b> <b>(R57) No. 11 — (R58) No. 2:</b>	Is the resistance less than 10 $\Omega$ ?	Go to step 7.	Repair the open circuit between coupling connector and fuel level sensor.

# DIAGNOSTIC PROCEDURE WITH DIAGNOSTIC TROUBLE CODE (DTC)

ENGINE (DIAGNOSTICS)

	Step	Check	Yes	No
7	<b>CHECK FUEL TANK CORD.</b> 1)Disconnect the connector from fuel sub level sensor. 2)Measure the resistance between fuel level sensor and fuel sub level sensor. <b>Connector &amp; terminal</b> <b>(R58) No. 7 — (R59) No. 2:</b>	Is the resistance less than 10 $\Omega$ ?	Go to step 8.	Repair the open circuit between fuel level sensor and fuel sub level sensor.
8	<b>CHECK FUEL TANK CORD.</b> Measure the resistance between fuel sub level sensor and coupling connector. <b>Connector &amp; terminal</b> <b>(R57) No. 2 — (R59) No. 1:</b>	Is the resistance less than 10 $\Omega$ ?	Go to step 9.	Repair the open circuit between coupling connector and fuel sub level sensor.
9	<b>CHECK FUEL LEVEL SENSOR.</b> 1)Remove the fuel pump assembly. <Ref. to FU(STi)-54, Fuel Pump.> 2)While moving the fuel level sensor float up and down, measure the resistance between fuel level sensor terminals. <b>Terminals</b> <b>No. 2 — No. 3:</b>	Is the resistance more than 53 $\Omega$ ?	Replace the fuel level sensor. <Ref. to FU(STi)-57, Fuel Level Sensor.>	Go to step 10.
10	<b>CHECK FUEL SUB LEVEL SENSOR.</b> 1)Remove the fuel sub level sensor. <Ref. to FU(STi)-58, Fuel Sub Level Sensor.> 2)While moving the fuel sub level sensor float up and down, measure the resistance between fuel sub level sensor terminals. <b>Terminals</b> <b>No. 1 — No. 2:</b>	Is the resistance more than 45 $\Omega$ ?	Replace the fuel sub level sensor. <Ref. to FU(STi)-58, Fuel Sub Level Sensor.>	Replace the combination meter. <Ref. to IDI-10, Combination Meter Assembly.>

## DIAGNOSTIC PROCEDURE WITH DIAGNOSTIC TROUBLE CODE (DTC)

ENGINE (DIAGNOSTICS)

---

### **BN:DTC P0464 — FUEL LEVEL SENSOR CIRCUIT INTERMITTENT —**

**• DTC DETECTING CONDITION:**

- Two consecutive driving cycles with fault
- GENERAL DESCRIPTION <Ref. to GD(STi)-165, DTC P0464 — FUEL LEVEL SENSOR CIRCUIT INTERMITTENT —, Diagnostic Trouble Code (DTC) Detecting Criteria.>

**CAUTION:**

**After repair or replacement of faulty parts, conduct Clear Memory Mode <Ref. to EN(STi)-42, OPERATION, Clear Memory Mode.> and Inspection Mode <Ref. to EN(STi)-35, OPERATION, Inspection Mode.>.**



# DIAGNOSTIC PROCEDURE WITH DIAGNOSTIC TROUBLE CODE (DTC) ENGINE (DIAGNOSTICS)

• WIRING DIAGRAM:

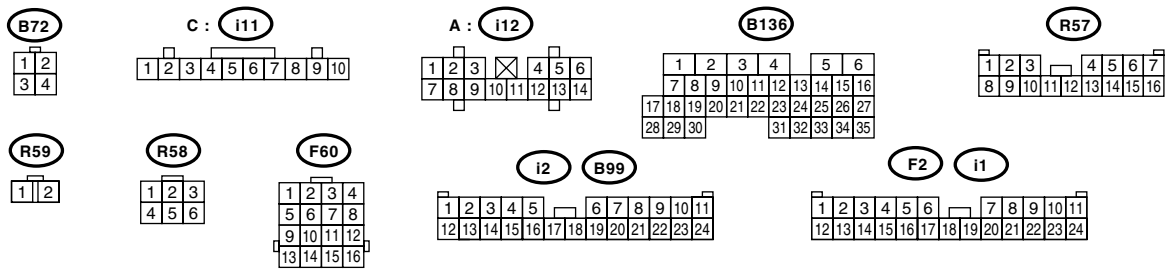
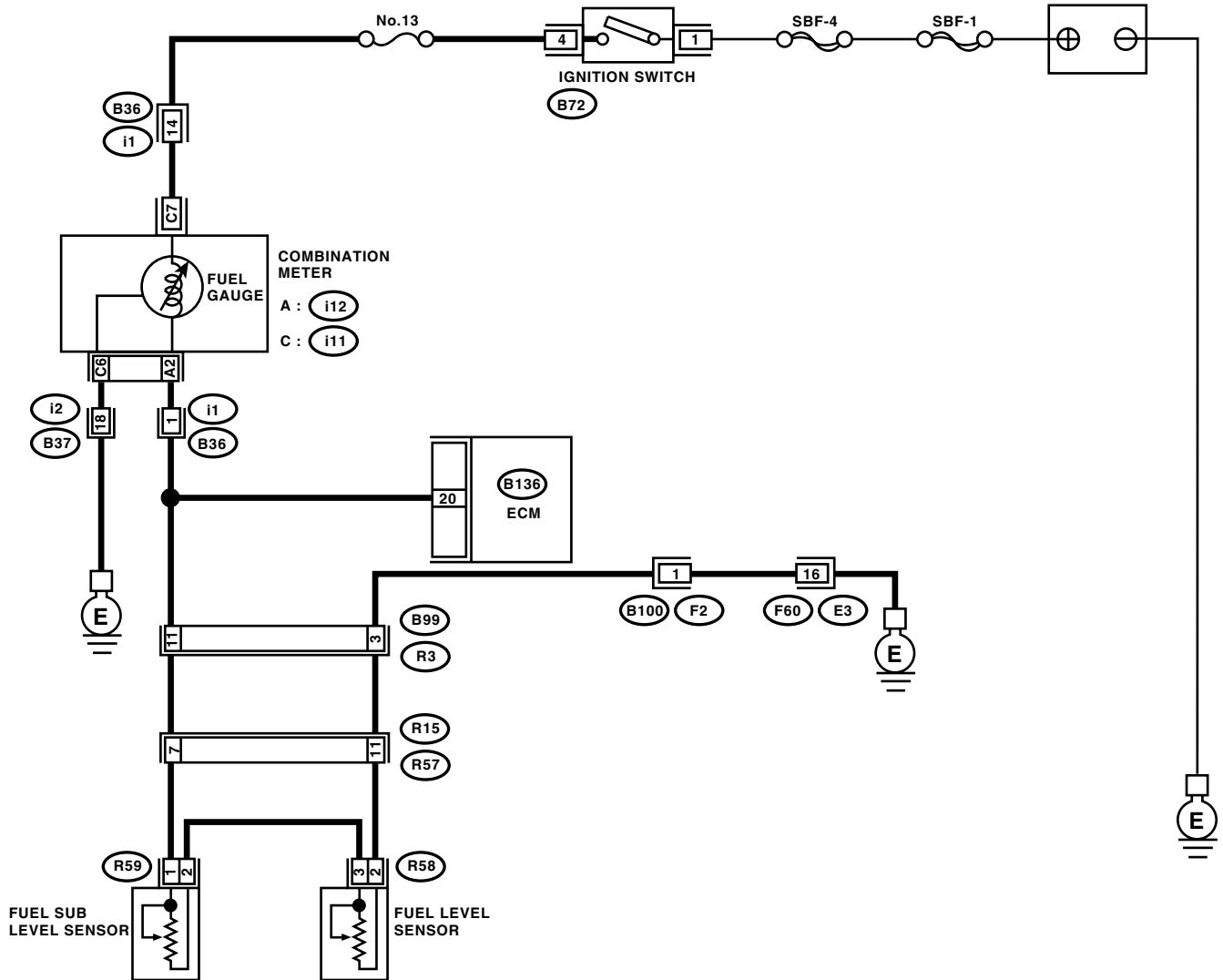

EN-01836

# DIAGNOSTIC PROCEDURE WITH DIAGNOSTIC TROUBLE CODE (DTC)

ENGINE (DIAGNOSTICS)

	Step	Check	Yes	No
1	<b>CHECK ANY OTHER DTC ON DISPLAY.</b>	Is any other DTC displayed?	Inspect the relevant DTC using "List of Diagnostic Trouble Code (DTC)". <Ref. to EN(STi)-66, List of Diagnostic Trouble Code (DTC).>	Go to step 2.
2	<b>CHECK FUEL LEVEL SENSOR.</b> 1)Remove the fuel pump assembly. <Ref. to FU(STi)-54, Fuel Pump.> 2)While moving the fuel level sensor float up and down, make sure that the resistance between fuel level sensor terminals changes smoothly. <b>Terminals</b> <b>No. 3 — No. 2:</b>	Does the resistance change smoothly?	Go to step 3.	Replace the fuel level sensor. <Ref. to FU(STi)-57, Fuel Level Sensor.>
3	<b>CHECK FUEL SUB LEVEL SENSOR.</b> 1)Remove the fuel sub level sensor. <Ref. to FU(STi)-58, Fuel Sub Level Sensor.> 2)While moving the fuel sub level sensor float up and down, make sure that the resistance between fuel level sensor terminals changes smoothly. <b>Terminals</b> <b>No. 1 — No. 2:</b>	Does the resistance change smoothly?	Repair the poor contact in ECM, combination meter and coupling connectors.	Replace the fuel sub level sensor. <Ref. to FU(STi)-58, Fuel Sub Level Sensor.>

## DIAGNOSTIC PROCEDURE WITH DIAGNOSTIC TROUBLE CODE (DTC)

ENGINE (DIAGNOSTICS)

### BO:DTC P0483 — COOLING FAN RATIONALITY CHECK —

• **DTC DETECTING CONDITION:**

- Two consecutive driving cycles with fault
- GENERAL DESCRIPTION <Ref. to GD(STi)-168, DTC P0483 — COOLING FAN RATIONALITY CHECK —, Diagnostic Trouble Code (DTC) Detecting Criteria.>

• **TROUBLE SYMPTOM:**

- Occurrence of noise
- Overheating

**CAUTION:**

After repair or replacement of faulty parts, conduct Clear Memory Mode <Ref. to EN(STi)-42, OPERATION, Clear Memory Mode.> and Inspection Mode <Ref. to EN(STi)-35, OPERATION, Inspection Mode.>.

**NOTE:**

If the vehicle, with the engine idling, is placed very close to a wall or another vehicle, preventing normal cooling function, the OBD system may detect malfunction.

# DIAGNOSTIC PROCEDURE WITH DIAGNOSTIC TROUBLE CODE (DTC)

## ENGINE (DIAGNOSTICS)

### • WIRING DIAGRAM:

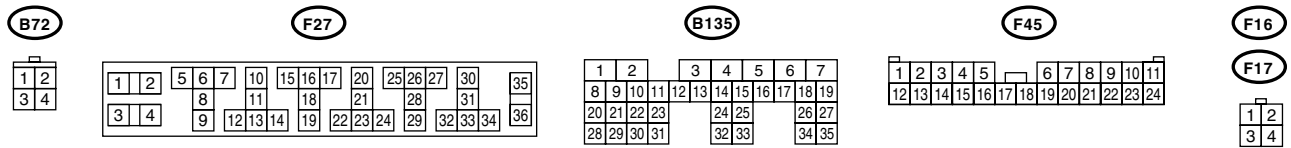
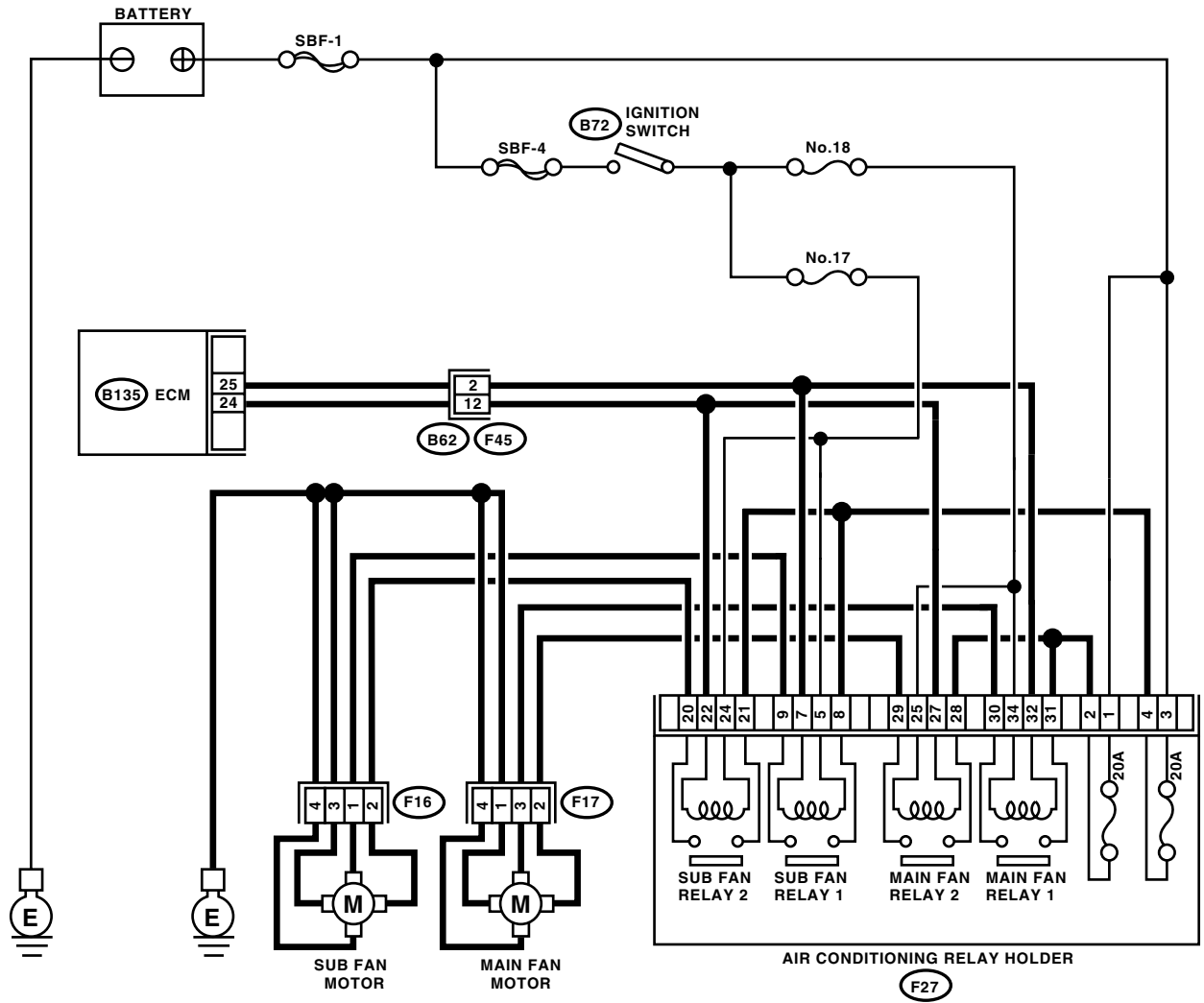

EN-01837

# DIAGNOSTIC PROCEDURE WITH DIAGNOSTIC TROUBLE CODE (DTC)

ENGINE (DIAGNOSTICS)

	Step	Check	Yes	No
1	<b>CHECK ANY OTHER DTC ON DISPLAY.</b>	Is any other DTC displayed?	Inspect the relevant DTC using "List of Diagnostic Trouble Code (DTC)". <Ref. to EN(STi)-66, List of Diagnostic Trouble Code (DTC).>	Check the radiator fan, fan motor and thermostat. <Ref. to CO(H4SO)-22, Radiator Main Fan and Fan Motor.> and <Ref. to CO(H4SO)-23, Radiator Sub Fan and Fan Motor.> If thermostat is stuck, replace thermostat.

# DIAGNOSTIC PROCEDURE WITH DIAGNOSTIC TROUBLE CODE (DTC)

ENGINE (DIAGNOSTICS)

## BP:DTC P0502 — VEHICLE SPEED SENSOR CIRCUIT LOW INPUT —

### • DTC DETECTING CONDITION:

- Immediately at fault recognition
- GENERAL DESCRIPTION <Ref. to GD(STi)-170, DTC P0502 — VEHICLE SPEED SENSOR CIRCUIT LOW INPUT —, Diagnostic Trouble Code (DTC) Detecting Criteria.>

### CAUTION:

After repair or replacement of faulty parts, conduct Clear Memory Mode <Ref. to EN(STi)-42, OPERATION, Clear Memory Mode.> and Inspection Mode <Ref. to EN(STi)-35, OPERATION, Inspection Mode.>.

### • WIRING DIAGRAM:

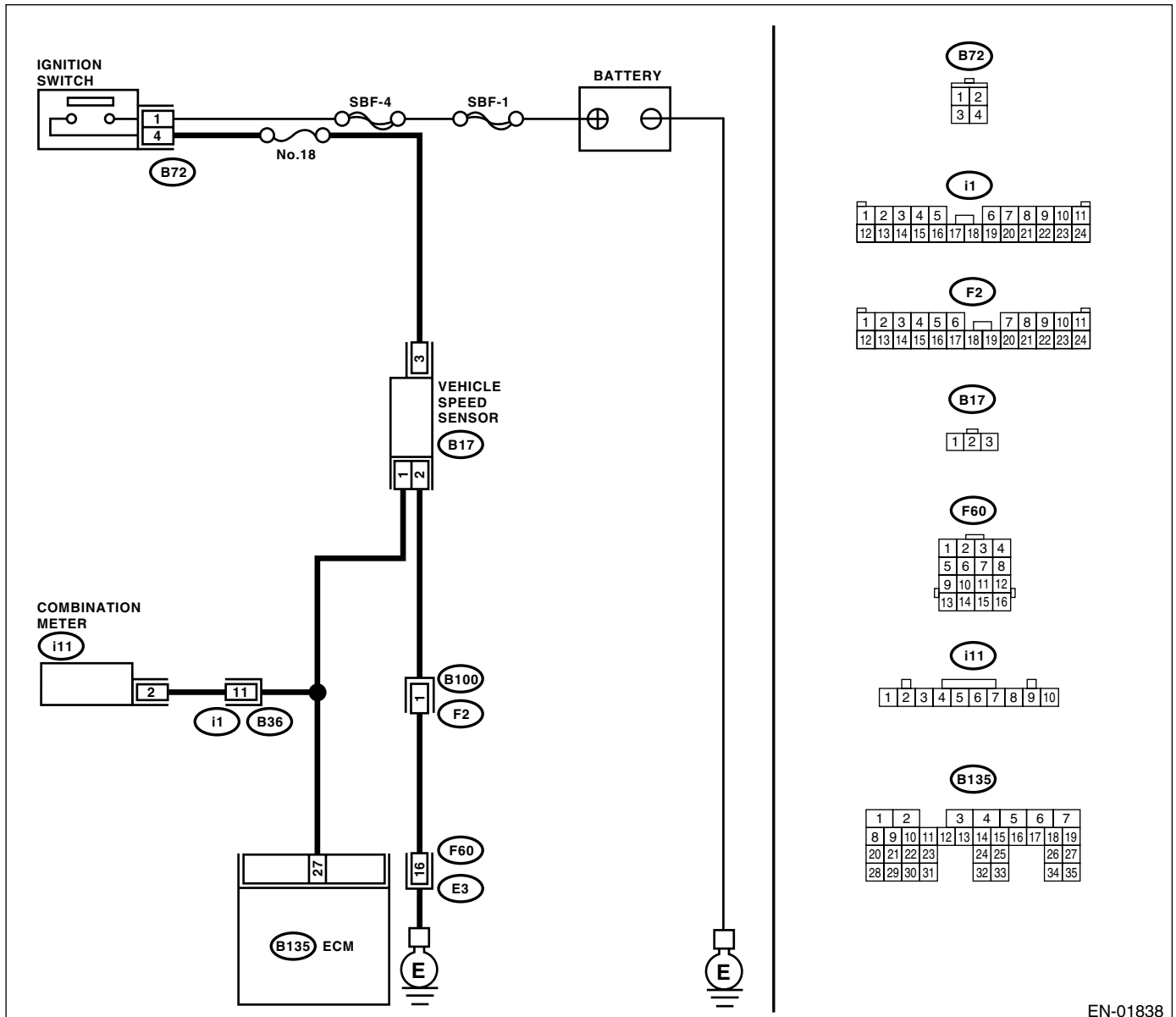

EN-01838

# DIAGNOSTIC PROCEDURE WITH DIAGNOSTIC TROUBLE CODE (DTC)

ENGINE (DIAGNOSTICS)

Step	Check	Yes	No
<b>1</b> <b>CHECK HARENESS BETWEEN VEHICLE SPEED SENSOR AND ECM CONNECTOR.</b> 1)Turn the ignition switch to OFF. 2)Disconnect the connectors from vehicle speed sensor and ECM. 3)Measure the resistance of harness between vehicle speed sensor connector and chassis ground. <b>Connector &amp; terminal</b> <b>(B17) No. 1 — Chassis ground:</b>	Is the resistance more than 1 MΩ?	Go to step 2.	Repair the ground short circuit in harness between vehicle speed sensor and ECM connector.
<b>2</b> <b>CHECK POOR CONTACT.</b> Check poor contact in the vehicle speed sensor connector.	Is there poor contact in the vehicle speed sensor connector?	Repair poor contact in the vehicle speed sensor connector.	Replace the vehicle speed sensor. <Ref. to 5MT-37, Vehicle Speed Sensor.>

# DIAGNOSTIC PROCEDURE WITH DIAGNOSTIC TROUBLE CODE (DTC)

ENGINE (DIAGNOSTICS)

## BQ:DTC P0503 — VEHICLE SPEED SENSOR INTERMITTENT/ERRATIC/HIGH —

### • DTC DETECTING CONDITION:

- Immediately at fault recognition
- GENERAL DESCRIPTION <Ref. to GD(STi)-172, DTC P0503 — VEHICLE SPEED SENSOR INTERMITTENT/ERRATIC/HIGH —, Diagnostic Trouble Code (DTC) Detecting Criteria.>

### CAUTION:

After repair or replacement of faulty parts, conduct Clear Memory Mode <Ref. to EN(STi)-42, OPERATION, Clear Memory Mode.> and Inspection Mode <Ref. to EN(STi)-35, OPERATION, Inspection Mode.>.

### • WIRING DIAGRAM:

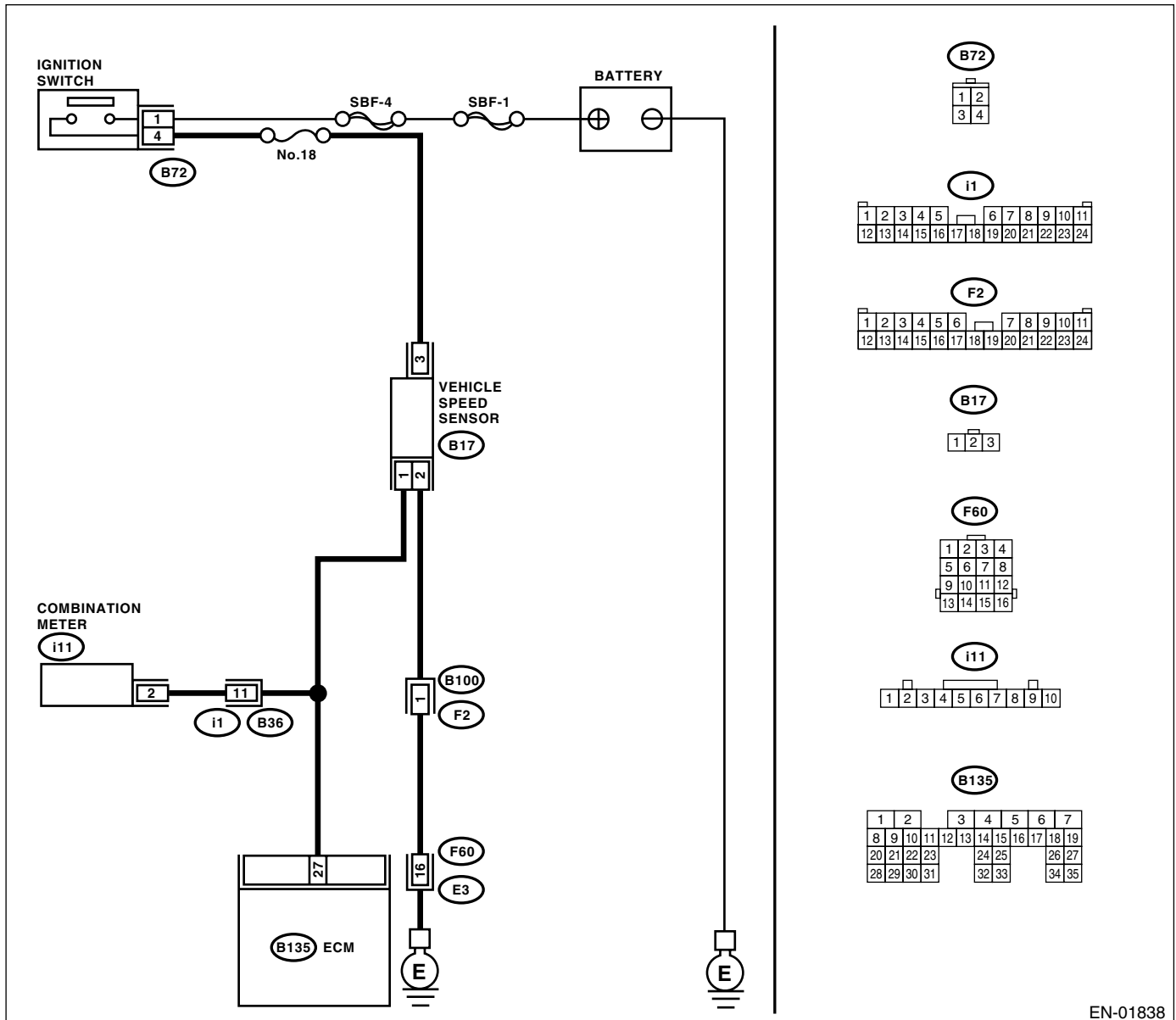

EN-01838

Step	Check	Yes	No
1	<b>CHECK SPEEDOMETER OPERATION IN COMBINATION METER.</b>	Does the speedometer operate normally?	Go to step 2.
			Check the speedometer. <Ref. to IDI-13, Speedometer.>



# DIAGNOSTIC PROCEDURE WITH DIAGNOSTIC TROUBLE CODE (DTC)

ENGINE (DIAGNOSTICS)

Step	Check	Yes	No
<p><b>2</b></p> <p><b>CHECK HARNESS BETWEEN ECM AND COMBINATION METER CONNECTOR.</b></p> <p>1) Turn the ignition switch to OFF.</p> <p>2) Disconnect the connector from combination meter.</p> <p>3) Measure the resistance between ECM and combination meter.</p> <p><b>Connector &amp; terminal</b> <b>(B135) No. 27 — (i11) No. 2:</b></p>	<p>Is the resistance less than 10 <math>\Omega</math>?</p>	<p>Repair the poor contact in ECM connector.</p>	<p>Repair the harness and connector.</p> <p>NOTE: In this case, repair the following:</p> <ul style="list-style-type: none"><li>• Open circuit in harness between ECM and combination meter connector</li><li>• Poor contact in ECM connector</li><li>• Poor contact in combination meter connector</li><li>• Poor contact in coupling connector</li></ul>

## DIAGNOSTIC PROCEDURE WITH DIAGNOSTIC TROUBLE CODE (DTC)

ENGINE (DIAGNOSTICS)

---

### **BR:DTC P0506 — IDLE CONTROL SYSTEM RPM LOWER THAN EXPECTED —**

• **DTC DETECTING CONDITION:**

- Two consecutive driving cycles with fault
- GENERAL DESCRIPTION <Ref. to GD(STi)-174, DTC P0506 — IDLE CONTROL SYSTEM RPM LOWER THAN EXPECTED —, Diagnostic Trouble Code (DTC) Detecting Criteria.>

• **TROUBLE SYMPTOM:**

- Engine is difficult to start.
- Engine does not start.
- Erroneous idling
- Engine stalls.

**CAUTION:**

**After repair or replacement of faulty parts, conduct Clear Memory Mode <Ref. to EN(STi)-42, OPERATION, Clear Memory Mode.> and Inspection Mode <Ref. to EN(STi)-35, OPERATION, Inspection Mode.>.**

# DIAGNOSTIC PROCEDURE WITH DIAGNOSTIC TROUBLE CODE (DTC) ENGINE (DIAGNOSTICS)

• WIRING DIAGRAM:

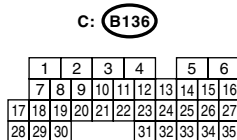
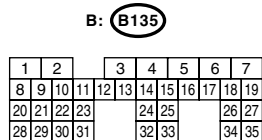
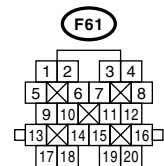
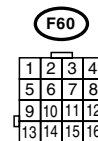
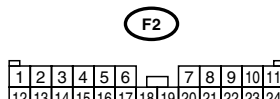
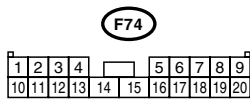
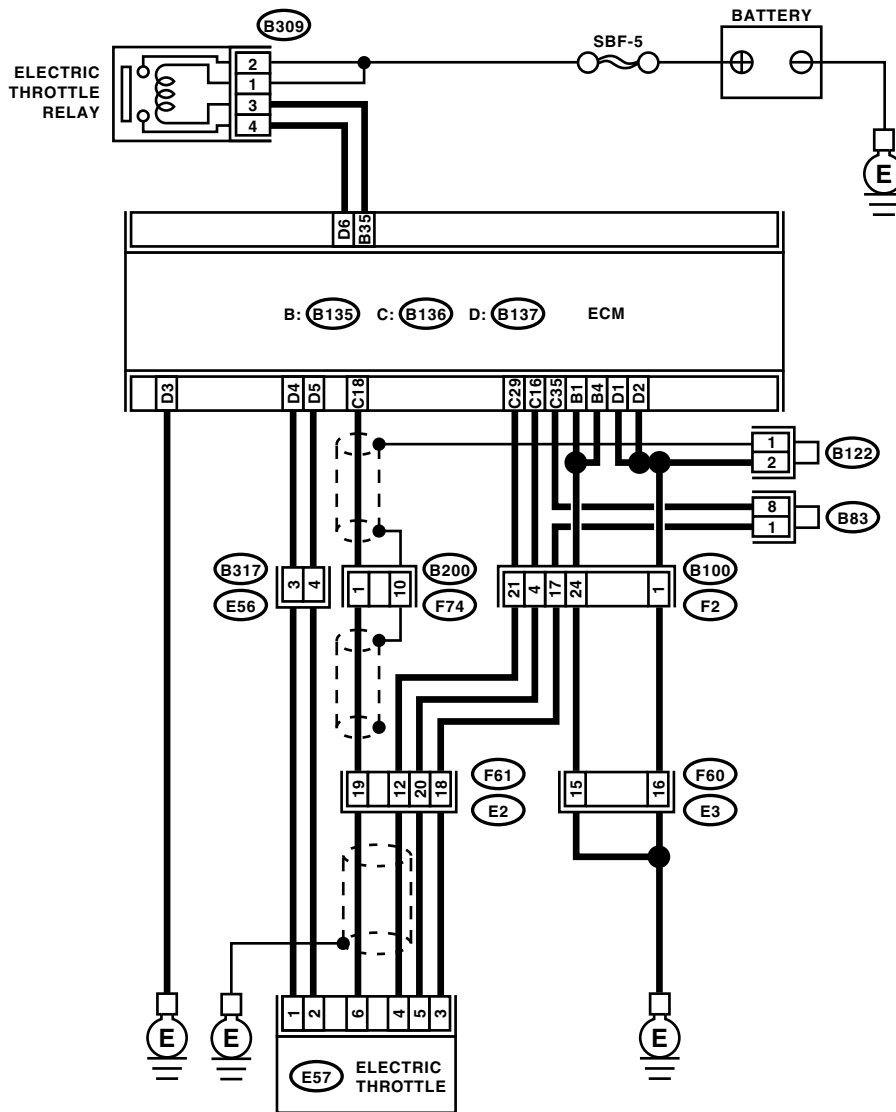

EN-01825

# DIAGNOSTIC PROCEDURE WITH DIAGNOSTIC TROUBLE CODE (DTC)

## ENGINE (DIAGNOSTICS)

	Step	Check	Yes	No
1	<b>CHECK ANY OTHER DTC ON DISPLAY.</b>	Is any other DTC displayed?	Inspect the relevant DTC using "List of Diagnostic Trouble Code (DTC)". <Ref. to EN(STi)-66, List of Diagnostic Trouble Code (DTC).> <b>NOTE:</b> In this case, it is not necessary to inspect DTC P0506.	Go to step 2.
2	<b>CHECK AIR CLEANER ELEMENT.</b> 1)Turn the ignition switch to OFF. 2)Check air cleaner element.	Is there excessive clogging on air cleaner element.	Replace the air cleaner element. <Ref. to IN(STi)-8, Air Cleaner.>	Go to step 3.
3	<b>CHECK ELECTRIC THROTTLE.</b> 1)Turn the ignition switch to OFF. 2)Remove the electric throttle. 3)Check the electric throttle.	Are there foreign particles in electric throttle?	Remove the foreign particles from electric throttle.	Perform the diagnosis of DTC P2101.

## DIAGNOSTIC PROCEDURE WITH DIAGNOSTIC TROUBLE CODE (DTC)

ENGINE (DIAGNOSTICS)

### **BS:DTC P0507 — IDLE CONTROL SYSTEM RPM HIGHER THAN EXPECTED —**

• **DTC DETECTING CONDITION:**

- Two consecutive driving cycles with fault
- GENERAL DESCRIPTION <Ref. to GD(STi)-176, DTC P0507 — IDLE CONTROL SYSTEM RPM HIGHER THAN EXPECTED —, Diagnostic Trouble Code (DTC) Detecting Criteria.>

• **TROUBLE SYMPTOM:**

- Engine keeps running at higher revolution than specified idling revolution.

**CAUTION:**

After repair or replacement of faulty parts, conduct Clear Memory Mode <Ref. to EN(STi)-42, OPERATION, Clear Memory Mode.> and Inspection Mode <Ref. to EN(STi)-35, OPERATION, Inspection Mode.>.

# DIAGNOSTIC PROCEDURE WITH DIAGNOSTIC TROUBLE CODE (DTC)

## ENGINE (DIAGNOSTICS)

### • WIRING DIAGRAM:

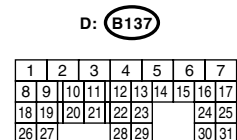
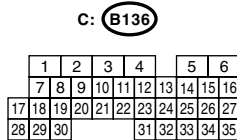
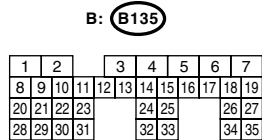
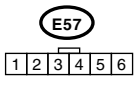
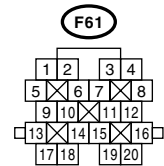
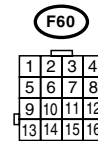
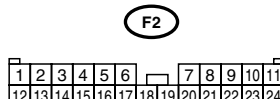
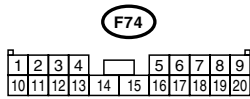
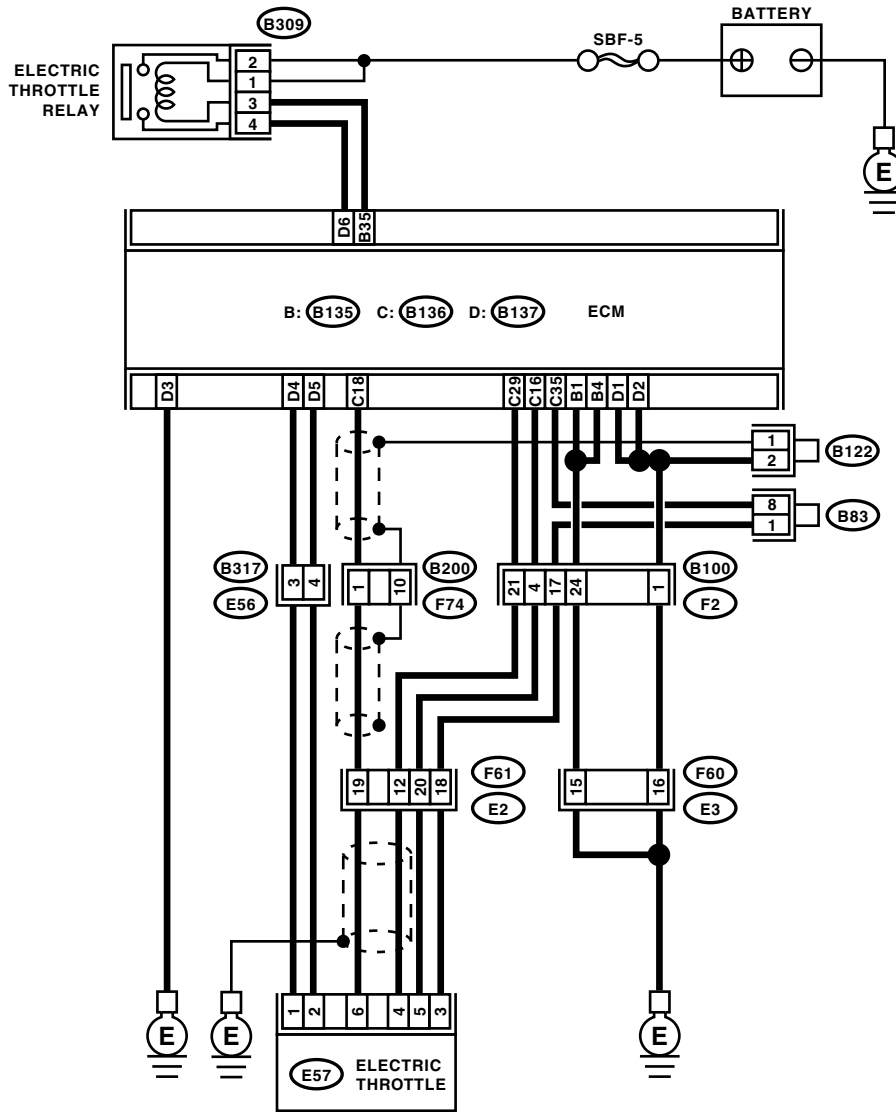

EN-01825

# DIAGNOSTIC PROCEDURE WITH DIAGNOSTIC TROUBLE CODE (DTC)

ENGINE (DIAGNOSTICS)

	Step	Check	Yes	No
1	<b>CHECK ANY OTHER DTC ON DISPLAY.</b>	Is any other DTC displayed?	Inspect the relevant DTC using "List of Diagnostic Trouble Code (DTC)". <Ref. to EN(STi)-66, List of Diagnostic Trouble Code (DTC).>  NOTE: In this case, it is not necessary to inspect DTC P0507.	Go to step 2.
2	<b>CHECK AIR INTAKE SYSTEM.</b> 1) Turn the ignition switch to ON. 2) Start the engine, and idle it. 3) Check the following items. • Loose installation of intake manifold and throttle body • Cracks of intake manifold gasket and throttle body gasket • Disconnections of vacuum hoses	Is there a fault in air intake system?	Repair the air suction and leaks.	Go to step 3.
3	<b>CHECK ELECTRIC THROTTLE.</b> 1) Turn the ignition switch to OFF. 2) Remove the electric throttle. 3) Check the electric throttle.	Are there foreign particles in electric throttle?	Remove the foreign particles from electric throttle.	Perform the diagnosis of DTC P2102.

## DIAGNOSTIC PROCEDURE WITH DIAGNOSTIC TROUBLE CODE (DTC)

ENGINE (DIAGNOSTICS)

---

### **BT:DTC P0512 — STARTER REQUEST CIRCUIT —**

• **DTC DETECTING CONDITION:**

- Immediately at fault recognition
- GENERAL DESCRIPTION <Ref. to GD(STi)-178, DTC P0512 — STARTER REQUEST CIRCUIT —, Diagnostic Trouble Code (DTC) Detecting Criteria.>

• **TROUBLE SYMPTOM:**

- Failure of engine to start

**CAUTION:**

After repair or replacement of faulty parts, conduct Clear Memory Mode <Ref. to EN(STi)-42, OPERATION, Clear Memory Mode.> and Inspection Mode <Ref. to EN(STi)-35, OPERATION, Inspection Mode.>.



# DIAGNOSTIC PROCEDURE WITH DIAGNOSTIC TROUBLE CODE (DTC) ENGINE (DIAGNOSTICS)

• WIRING DIAGRAM:

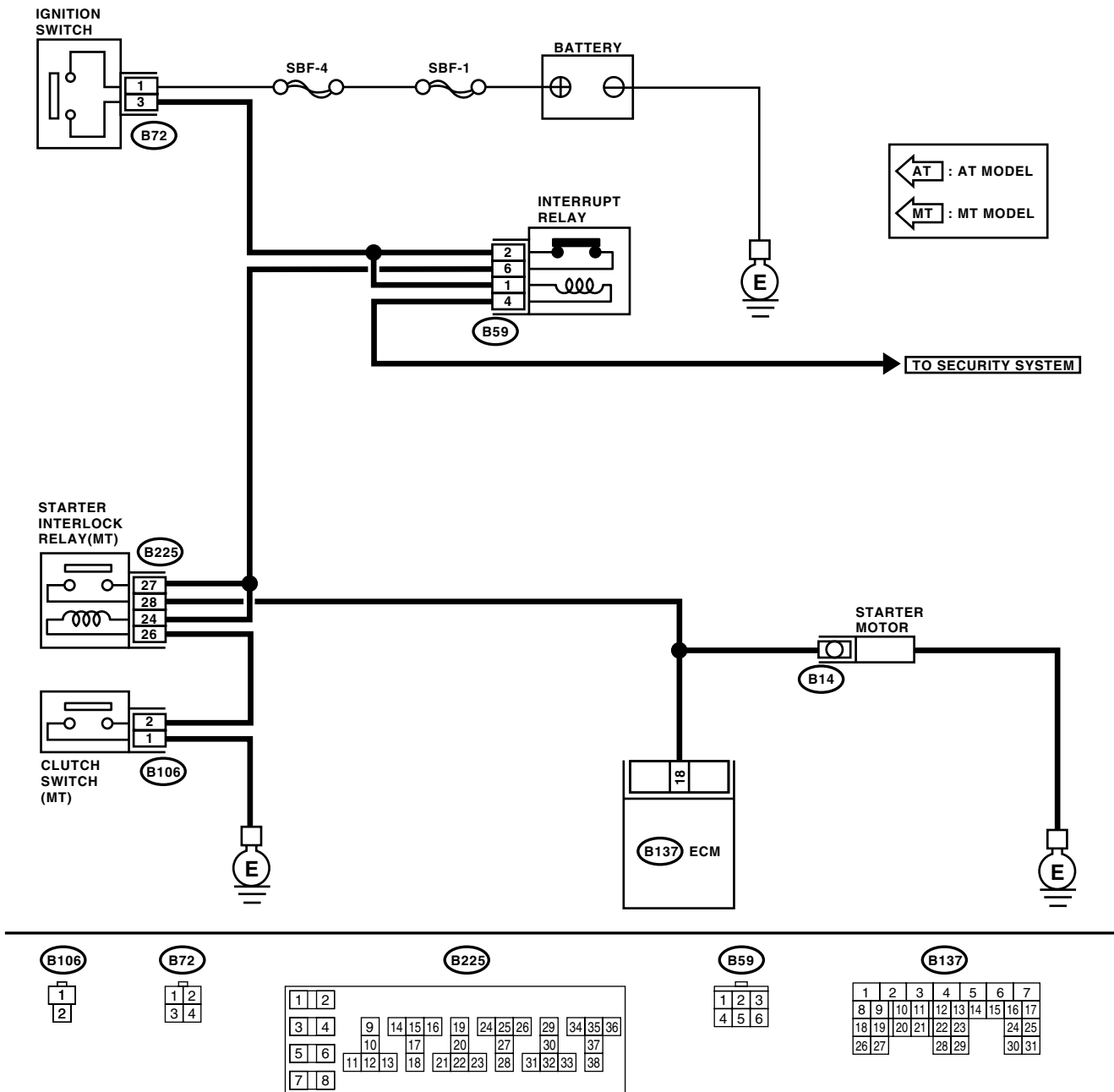

EN-01815

# DIAGNOSTIC PROCEDURE WITH DIAGNOSTIC TROUBLE CODE (DTC)

ENGINE (DIAGNOSTICS)

Step	Check	Yes	No
1 <b>CHECK OPERATION OF STARTER MOTOR.</b>	Does the starter motor operate when ignition switch is turned to ON?	Repair the battery short circuit in starter motor circuit. After repair, replace the ECM. <Ref. to FU(STi)-41, Engine Control Module (ECM).>	Check the starter motor circuit. <Ref. to EN(STi)-55, STARTER MOTOR CIRCUIT, Diagnostics for Engine Starting Failure.>

## DIAGNOSTIC PROCEDURE WITH DIAGNOSTIC TROUBLE CODE (DTC)

ENGINE (DIAGNOSTICS)

### **BU:DTC P0519 — IDLE CONTROL SYSTEM MALFUNCTION (FAIL-SAFE) —**

• **DTC DETECTING CONDITION:**

- Immediately at fault recognition
- GENERAL DESCRIPTION <Ref. to GD(STi)-179, DTC P0519 — IDLE CONTROL SYSTEM MALFUNCTION (FAIL-SAFE) —, Diagnostic Trouble Code (DTC) Detecting Criteria.>

• **TROUBLE SYMPTOM:**

- Engine keeps running at higher revolution than specified idling revolution.
- Fuel is cut according to fail-safe function.

**CAUTION:**

After repair or replacement of faulty parts, conduct Clear Memory Mode <Ref. to EN(STi)-42, OPERATION, Clear Memory Mode.> and Inspection Mode <Ref. to EN(STi)-35, OPERATION, Inspection Mode.>.

# DIAGNOSTIC PROCEDURE WITH DIAGNOSTIC TROUBLE CODE (DTC)

## ENGINE (DIAGNOSTICS)

### • WIRING DIAGRAM:

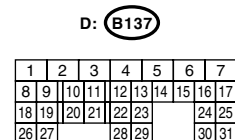
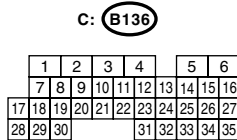
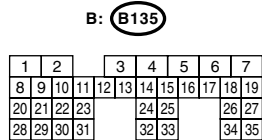
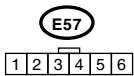
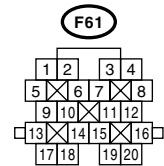
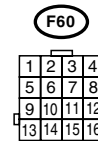
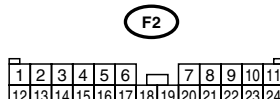
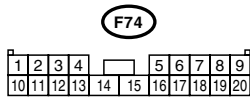
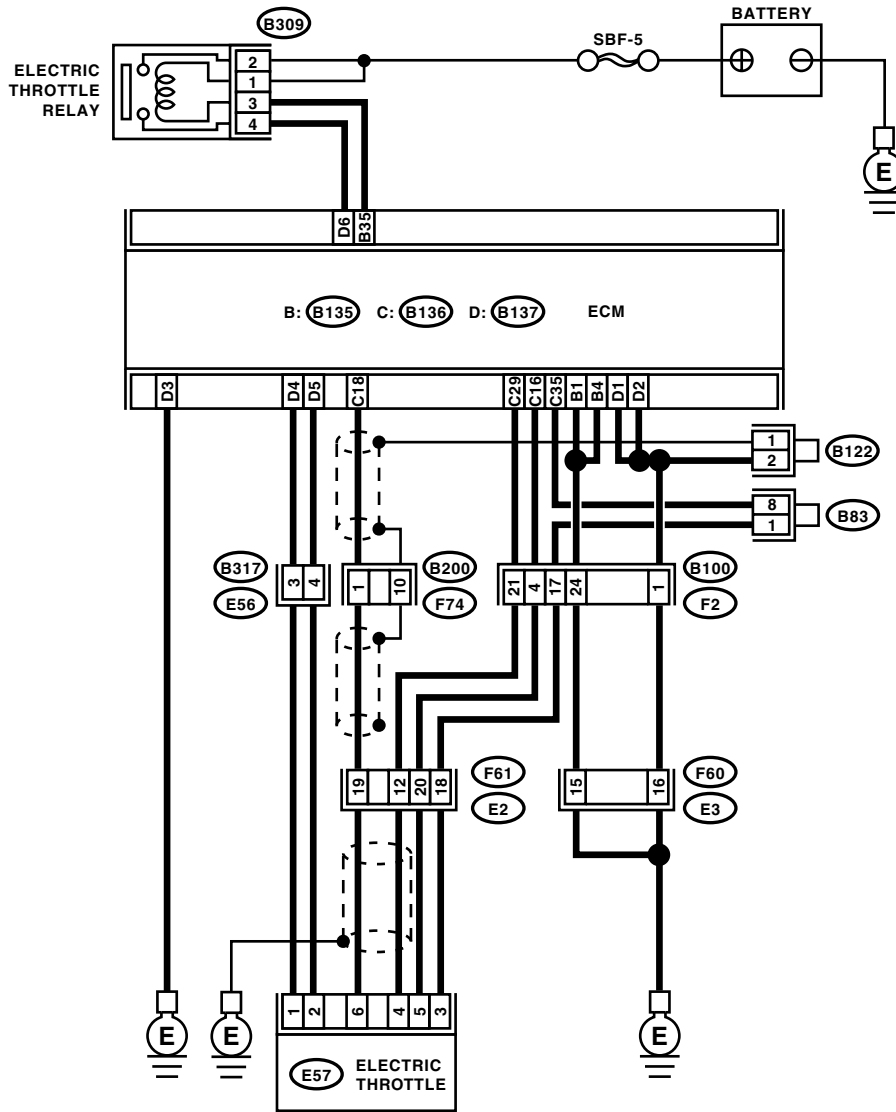

EN-01825

# DIAGNOSTIC PROCEDURE WITH DIAGNOSTIC TROUBLE CODE (DTC)

## ENGINE (DIAGNOSTICS)

Step	Check	Yes	No
<b>1</b> <b>CHECK ANY OTHER DTC ON DISPLAY.</b>	Is any other DTC displayed?	Inspect the relevant DTC using "List of Diagnostic Trouble Code (DTC)". <Ref. to EN(STi)-66, List of Diagnostic Trouble Code (DTC).>  NOTE: In this case, it is not necessary to inspect DTC P0519.	Go to step 2.
<b>2</b> <b>CHECK AIR INTAKE SYSTEM.</b> 1) Turn the ignition switch to ON. 2) Start the engine, and idle it. 3) Check the following items. <ul style="list-style-type: none"> <li>• Loose installation of intake manifold and throttle body</li> <li>• Cracks of intake manifold gasket and throttle body gasket</li> <li>• Disconnections of vacuum hoses</li> </ul>	Is there a fault in air intake system?	Repair the air suction and leaks.	Go to step 3.
<b>3</b> <b>CHECK ELECTRIC THROTTLE.</b> 1) Turn the ignition switch to OFF. 2) Remove the electric throttle. 3) Check the electric throttle.	Are there foreign particles in electric throttle?	Remove the foreign particles from electric throttle.	Perform the diagnosis of DTC P2102.

## DIAGNOSTIC PROCEDURE WITH DIAGNOSTIC TROUBLE CODE (DTC)

ENGINE (DIAGNOSTICS)

---

### **BV:DTC P0604 — INTERNAL CONTROL MODULE RANDOM ACCESS MEMORY (RAM) ERROR —**

• **DTC DETECTING CONDITION:**

- Immediately at fault recognition
- GENERAL DESCRIPTION <Ref. to GD(STi)-181, DTC P0604 — INTERNAL CONTROL MODULE RANDOM ACCESS MEMORY (RAM) ERROR —, Diagnostic Trouble Code (DTC) Detecting Criteria.>

• **TROUBLE SYMPTOM:**

- Engine does not start.
- Engine stalls.

**CAUTION:**

After repair or replacement of faulty parts, conduct Clear Memory Mode <Ref. to EN(STi)-42, OPERATION, Clear Memory Mode.> and Inspection Mode <Ref. to EN(STi)-35, OPERATION, Inspection Mode.>.

# DIAGNOSTIC PROCEDURE WITH DIAGNOSTIC TROUBLE CODE (DTC) ENGINE (DIAGNOSTICS)

## • WIRING DIAGRAM:

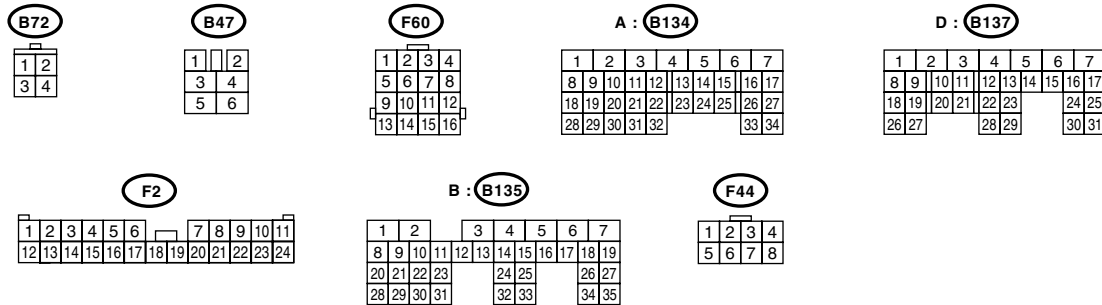
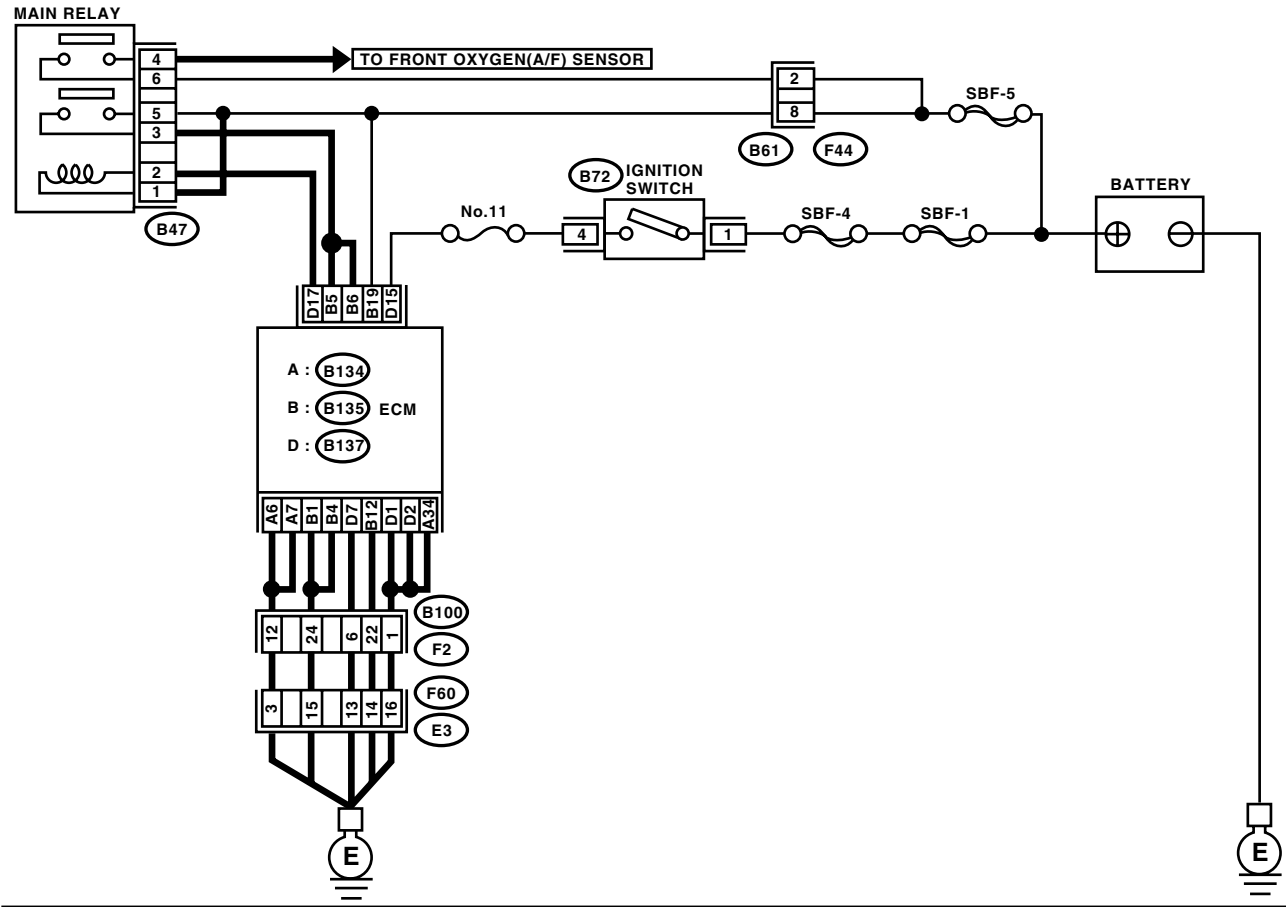

EN-01816

Step	Check	Yes	No
1	<b>CHECK ANY OTHER DTC ON DISPLAY.</b> Does the Subaru Select Monitor or OBD-II general scan tool indicate DTC P0604?	Replace the ECM. <Ref. to FU(STi)-41, Engine Control Module (ECM).>	A temporary poor contact.

## **DIAGNOSTIC PROCEDURE WITH DIAGNOSTIC TROUBLE CODE (DTC)**

ENGINE (DIAGNOSTICS)

---

### **BW:DTC P0605 — INTERNAL CONTROL MODULE READ ONLY MEMORY (ROM) ERROR —**

NOTE:

For the diagnostic procedure, refer to DTC P0607. <Ref. to EN(STi)-249, DTC P0607 — CONTROL MODULE PERFORMANCE —, Diagnostic Procedure with Diagnostic Trouble Code (DTC).>



## DIAGNOSTIC PROCEDURE WITH DIAGNOSTIC TROUBLE CODE (DTC)

ENGINE (DIAGNOSTICS)

### **BX:DTC P0607 — CONTROL MODULE PERFORMANCE —**

• **DTC DETECTING CONDITION:**

- Immediately at fault recognition
- GENERAL DESCRIPTION <Ref. to GD(STi)-183, DTC P0605 — INTERNAL CONTROL MODULE READ ONLY MEMORY (ROM) ERROR —, Diagnostic Trouble Code (DTC) Detecting Criteria.> and <Ref. to GD(STi)-184, DTC P0607 — CONTROL MODULE PERFORMANCE —, Diagnostic Trouble Code (DTC) Detecting Criteria.>

• **TROUBLE SYMPTOM:**

- Erroneous idling
- Poor driving performance

**CAUTION:**

After repair or replacement of faulty parts, conduct Clear Memory Mode <Ref. to EN(STi)-42, OPERATION, Clear Memory Mode.> and Inspection Mode <Ref. to EN(STi)-35, OPERATION, Inspection Mode.>.

# DIAGNOSTIC PROCEDURE WITH DIAGNOSTIC TROUBLE CODE (DTC)

## ENGINE (DIAGNOSTICS)

### • WIRING DIAGRAM:

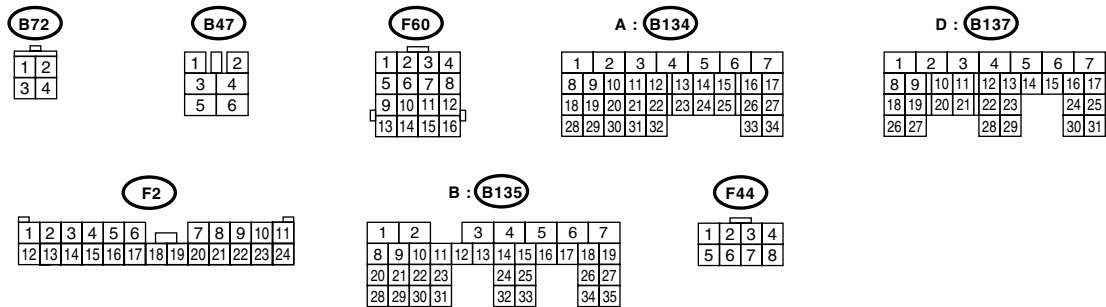
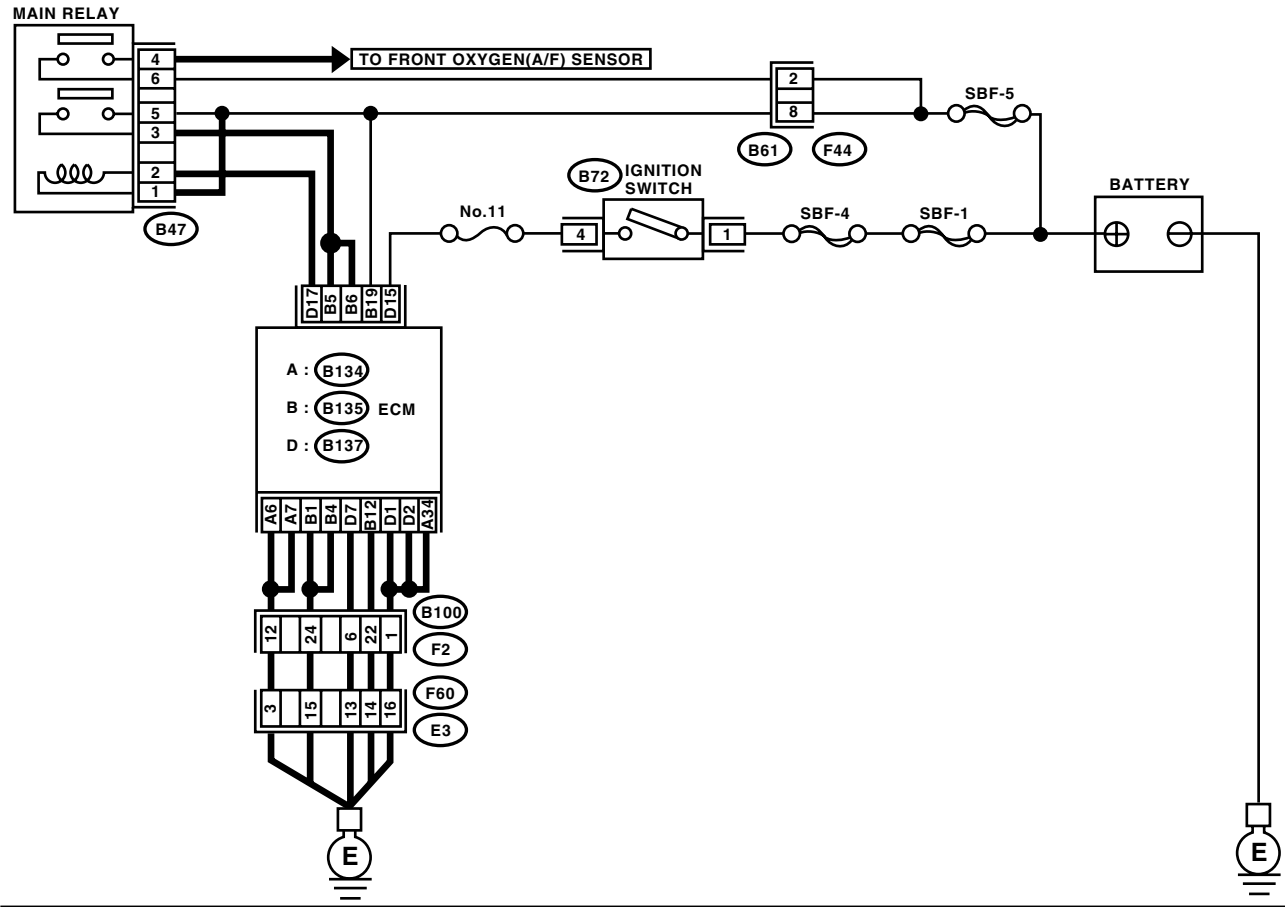

EN-01816

Step	Check	Yes	No
<b>1</b> <b>CHECK INPUT VOLTAGE OF ECM</b> 1) Turn the ignition switch to ON. 2) Measure the voltage between ECM connector and ground. <i>Connector &amp; terminal</i> (B135) No. 5 (+) — Chassis ground (-): (B135) No. 6 (+) — Chassis ground (-):	Is the voltage 10 — 13 V?	Go to step 2.	Repair the open circuit or ground short of power supply circuit.

# DIAGNOSTIC PROCEDURE WITH DIAGNOSTIC TROUBLE CODE (DTC)

ENGINE (DIAGNOSTICS)

	Step	Check	Yes	No
2	<b>CHECK INPUT VOLTAGE OF ECM</b> 1)Start the engine. 2)Measure the voltage between ECM connector and ground. <b>Connector &amp; terminal</b> <i>(B135) No. 5 (+) — Chassis ground (-):</i> <i>(B135) No. 6 (+) — Chassis ground (-):</i>	Is the voltage 13 — 15 V?	Go to step 3.	Repair the open circuit or ground short of power supply circuit.
3	<b>CHECK GROUND HARNESS OF ECM</b> Measure the voltage between ECM connector and ground. <b>Connector &amp; terminal</b> <i>(B137) No. 1 (+) — Chassis ground (-):</i> <i>(B137) No. 2 (+) — Chassis ground (-):</i>	Is the voltage less than 1 V?	Repair poor contact of ECM connector. If poor contact occur, replace the ECM.	Retighten the engine ground terminal.

## BY:DTC P0638 — THROTTLE ACTUATOR CONTROL RANGE/PERFORMANCE (BANK 1) —

### NOTE:

For the diagnostic procedure, refer to DTC P2101. <Ref. to EN(STi)-325, DTC P2101 — THROTTLE ACTUATOR CONTROL MOTOR CIRCUIT RANGE/PERFORMANCE —, Diagnostic Procedure with Diagnostic Trouble Code (DTC).>

## DIAGNOSTIC PROCEDURE WITH DIAGNOSTIC TROUBLE CODE (DTC)

ENGINE (DIAGNOSTICS)

---

### **BZ:DTC P0691 — COOLING FAN 1 CONTROL CIRCUIT LOW —**

• **DTC DETECTING CONDITION:**

- Two consecutive driving cycles with fault
- GENERAL DESCRIPTION <Ref. to GD(STi)-190, DTC P0691 — COOLING FAN 1 CONTROL CIRCUIT LOW —, Diagnostic Trouble Code (DTC) Detecting Criteria.>

• **TROUBLE SYMPTOM:**

- Radiator fan does not operate properly.
- Overheating

**CAUTION:**

After repair or replacement of faulty parts, conduct Clear Memory Mode <Ref. to EN(STi)-42, OPERATION, Clear Memory Mode.> and Inspection Mode <Ref. to EN(STi)-35, OPERATION, Inspection Mode.>.

# DIAGNOSTIC PROCEDURE WITH DIAGNOSTIC TROUBLE CODE (DTC) ENGINE (DIAGNOSTICS)

• WIRING DIAGRAM:

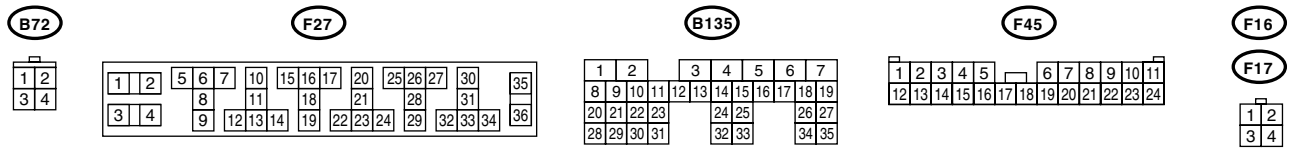
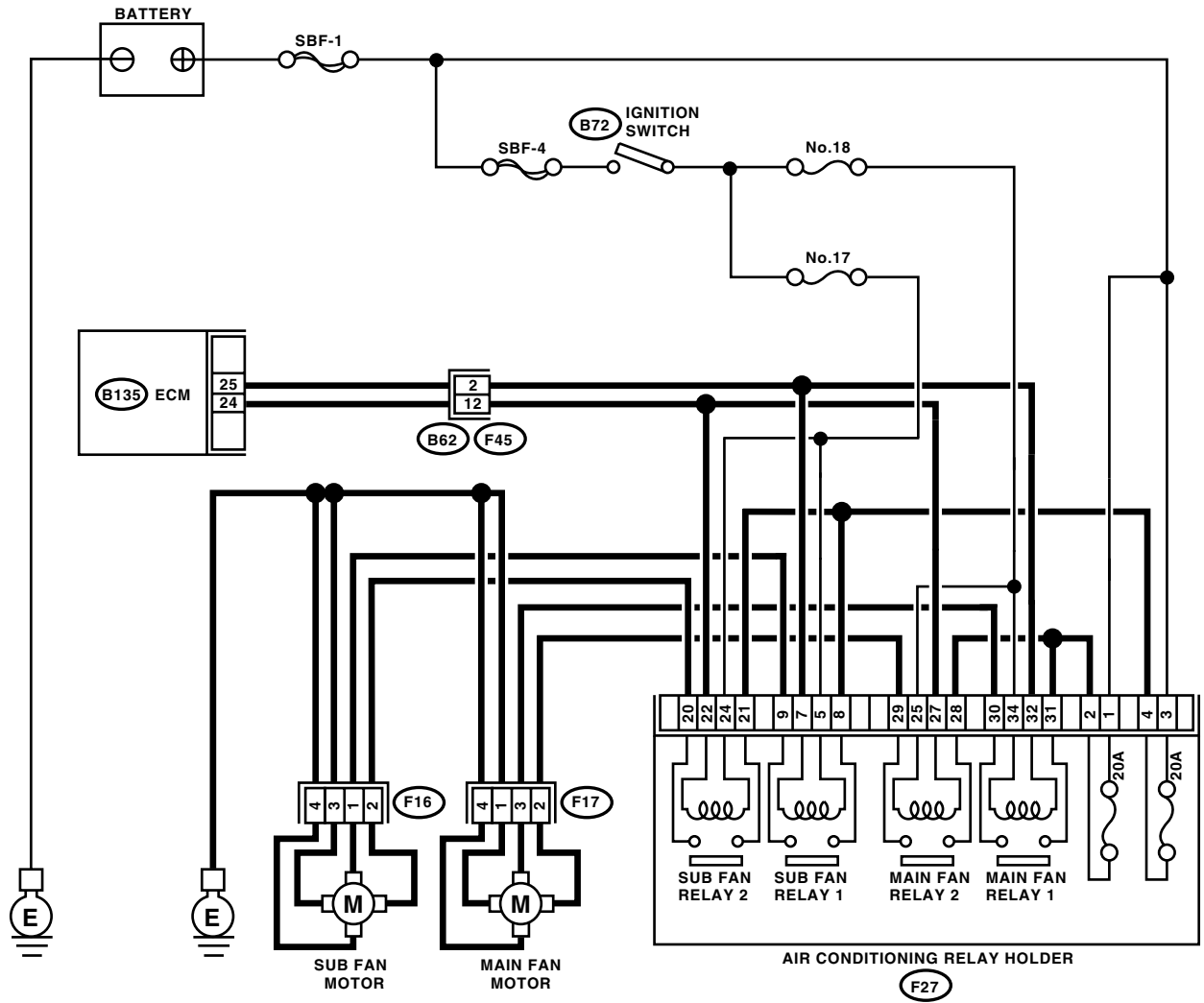

EN-01837

# DIAGNOSTIC PROCEDURE WITH DIAGNOSTIC TROUBLE CODE (DTC)

## ENGINE (DIAGNOSTICS)

Step	Check	Yes	No
<p><b>1 CHECK OUTPUT SIGNAL FROM ECM.</b>                      1) Turn the ignition switch to OFF.                      2) Connect the test mode connector.                      3) Turn the ignition switch to ON.                      4) While operating the radiator fan relay, measure voltage between ECM terminal and ground.</p> <p><b>NOTE:</b>                      Radiator fan relay operation can be executed using Subaru Select Monitor. For procedure, refer to "Compulsory Valve Operation Check Mode". &lt;Ref. to EN(STi)-28, Subaru Select Monitor.&gt;</p> <p><b>Connector &amp; terminal</b>                      (B135) No. 25 (+) — Chassis ground (-):                      (B135) No. 24 (+) — Chassis ground (-):</p>	Does the voltage change 0 — 10 V?	Repair poor contact in ECM connector.	Go to step 2.
<p><b>2 CHECK GROUND SHORT CIRCUIT IN RADIATOR FAN RELAY CONTROL CIRCUIT.</b>                      1) Turn the ignition switch to OFF.                      2) Disconnect the connectors from ECM.                      3) Measure the resistance of harness between ECM connector and chassis ground.</p> <p><b>Connector &amp; terminal</b>                      (B135) No. 25 — Chassis ground:                      (B135) No. 24 — Chassis ground:</p>	Is the resistance more than 1 MΩ?	Go to step 3.	Repair ground short circuit in radiator fan relay control circuit.
<p><b>3 CHECK POWER SUPPLY FOR RELAY.</b>                      1) Remove the main fan relay 1 and main fan relay 2 from A/C relay holder.                      2) Turn the ignition switch to ON.                      3) Measure the voltage between fuse and relay box (F/B) connector and chassis ground.</p> <p><b>Connector &amp; terminal</b>                      (F27) No. 27 (+) — Chassis ground (-):                      (F27) No. 32 (+) — Chassis ground (-):</p>	Is the voltage more than 10 V?	Go to step 4.	Repair open circuit in harness between ignition switch and fuse and relay box (F/B) connector.
<p><b>4 CHECK MAIN FAN RELAY.</b>                      1) Turn the ignition switch to OFF.                      2) Measure the resistance between main fan relay terminals.</p> <p><b>Terminals</b>                      No. 32 — No. 34: (Main fan relay 1)                      No. 25 — No. 27: (Main fan relay 2)</p>	Is the resistance 87 — 107 Ω?	Go to step 5.	Replace the main fan relay.
<p><b>5 CHECK OPEN CIRCUIT IN MAIN FAN RELAY CONTROL CIRCUIT.</b>                      Measure the resistance of harness between ECM and fan relay connector.</p> <p><b>Connector &amp; terminal</b>                      (B135) No. 25 — (F27) No. 32:                      (B135) No. 24 — (F27) No. 27:</p>	Is the resistance less than 1 Ω?	Go to step 6.	Repair harness and connector.  <b>NOTE:</b> In this case, repair the following: • Open circuit in harness between ECM and fan relay connector • Poor contact in coupling connector
<p><b>6 CHECK POOR CONTACT.</b>                      Check poor contact in ECM or fan relay connector.</p>	Is there poor contact in ECM or fan relay connector?	Repair poor contact in ECM or fan relay connector.	Contact your SOA Service Center.

## DIAGNOSTIC PROCEDURE WITH DIAGNOSTIC TROUBLE CODE (DTC)

ENGINE (DIAGNOSTICS)

### CA:DTC P0692 — COOLING FAN 1 CONTROL CIRCUIT HIGH —

- **DTC DETECTING CONDITION:**

- Two consecutive driving cycles with fault
- GENERAL DESCRIPTION <Ref. to GD(STi)-191, DTC P0692 — COOLING FAN 1 CONTROL CIRCUIT HIGH —, Diagnostic Trouble Code (DTC) Detecting Criteria.>

- **TROUBLE SYMPTOM:**

- Radiator fan does not operate properly.
- Overheating

**CAUTION:**

After repair or replacement of faulty parts, conduct Clear Memory Mode <Ref. to EN(STi)-42, OPERATION, Clear Memory Mode.> and Inspection Mode <Ref. to EN(STi)-35, OPERATION, Inspection Mode.>.

# DIAGNOSTIC PROCEDURE WITH DIAGNOSTIC TROUBLE CODE (DTC)

## ENGINE (DIAGNOSTICS)

### • WIRING DIAGRAM:

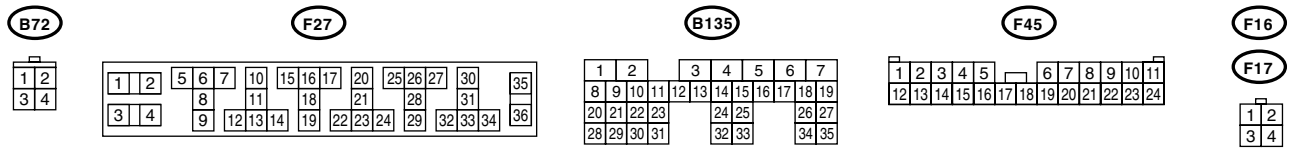
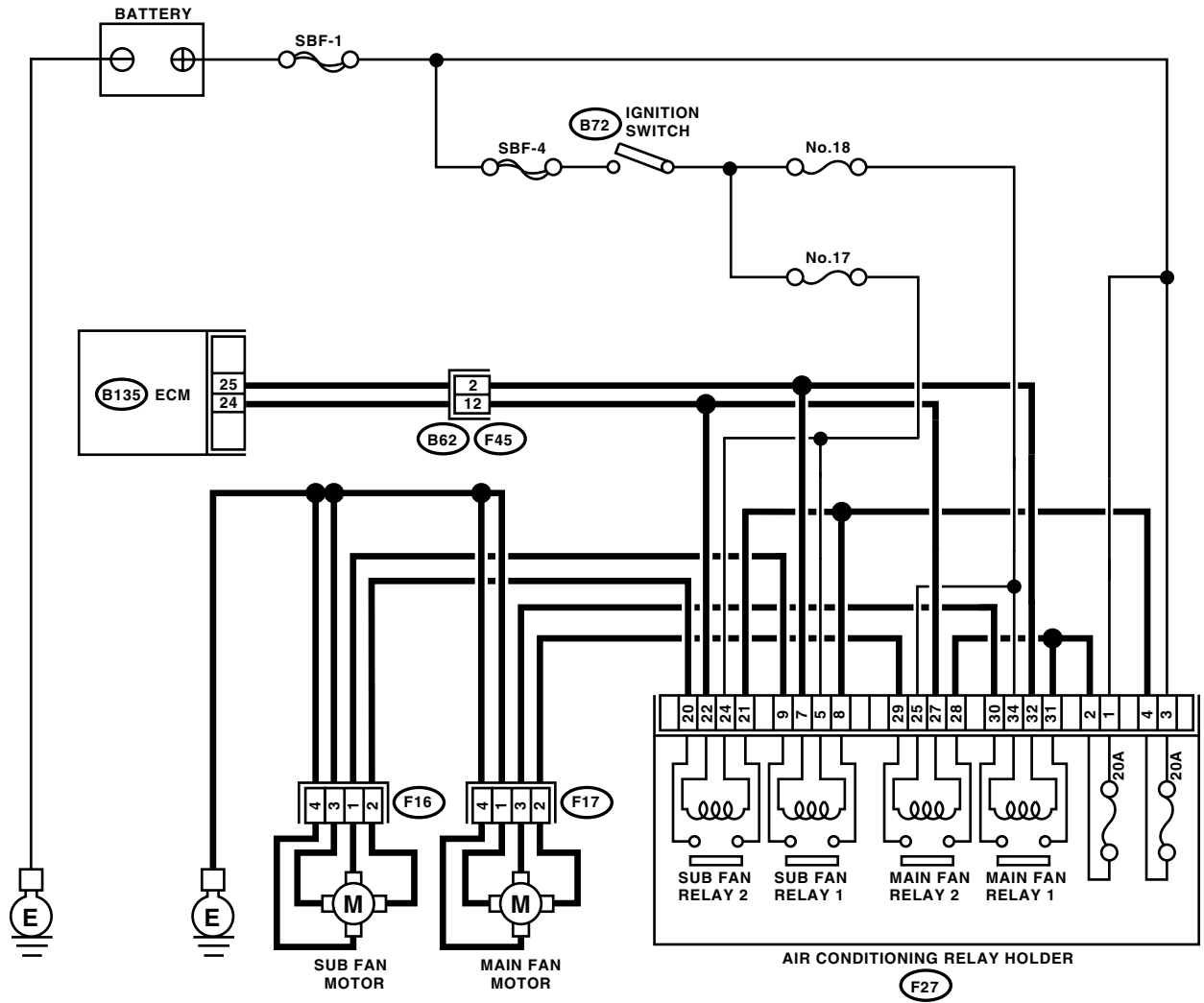

EN-01837



# DIAGNOSTIC PROCEDURE WITH DIAGNOSTIC TROUBLE CODE (DTC)

ENGINE (DIAGNOSTICS)

Step	Check	Yes	No
<p><b>1 CHECK OUTPUT SIGNAL FROM ECM.</b>                      1) Turn the ignition switch to OFF.                      2) Connect the test mode connector.                      3) Turn the ignition switch to ON.                      4) While operating the radiator fan relay, measure the voltage between ECM and chassis ground.</p> <p><b>NOTE:</b>                      Radiator fan relay operation can be executed using the Subaru Select Monitor. For procedure, refer to "Compulsory Valve Operation Check Mode". &lt;Ref. to EN(STi)-43, Compulsory Valve Operation Check Mode.&gt;</p> <p><b>Connector &amp; terminal</b>                      (B135) No. 25 (+) — Chassis ground (-):                      (B135) No. 24 (+) — Chassis ground (-):</p>	<p>Does the voltage change 0 — 10 V?</p>	<p>Even if malfunction indicator light lights up, the circuit has returned to a normal condition at this time. In this case, repair the poor contact in ECM connector.</p>	<p>Go to step 2.</p>
<p><b>2 CHECK SHORT CIRCUIT IN RADIATOR FAN RELAY CONTROL CIRCUIT.</b>                      1) Turn the ignition switch to OFF.                      2) Remove the fan relay 1, fan relay 2 and fan mode relay.                      3) Disconnect the test mode connector.                      4) Turn the ignition switch to ON.                      5) Measure the voltage between ECM and chassis ground.</p> <p><b>Connector &amp; terminal</b>                      (B135) No. 25 (+) — Chassis ground (-):                      (B135) No. 24 (+) — Chassis ground (-):</p>	<p>Is the voltage more than 10 V?</p>	<p>Repair the battery short circuit in radiator fan relay control circuit. After repair, replace the ECM. &lt;Ref. to FU(STi)-41, Engine Control Module (ECM).&gt;</p>	<p>Go to step 3.</p>
<p><b>3 CHECK MAIN FAN RELAY.</b>                      1) Turn the ignition switch to OFF.                      2) Remove the main fan relay.                      3) Measure the resistance between main fan relay terminals.</p> <p><b>Terminals</b>                      No. 30 — No. 31: (Main fan relay 1)                      No. 28 — No. 29: (Main fan relay 2)</p>	<p>Is the resistance less than 1 <math>\Omega</math>?</p>	<p>Replace the main fan relay and ECM. &lt;Ref. to FU(STi)-41, Engine Control Module (ECM).&gt;</p>	<p>Go to step 4.</p>
<p><b>4 CHECK SUB FAN RELAY.</b>                      1) Remove the sub fan relay.                      2) Measure the resistance between sub fan relay terminals.</p> <p><b>Terminals</b>                      No. 8 — No. 9: (Sub fan relay 1)                      No. 20 — No. 21: (Sub fan relay 2)</p>	<p>Is the resistance less than 1 <math>\Omega</math>?</p>	<p>Replace the sub fan relay and ECM. &lt;Ref. to FU(STi)-41, Engine Control Module (ECM).&gt;</p>	<p>Go to step 5.</p>
<p><b>5 CHECK POOR CONTACT.</b>                      Check poor contact in ECM connector.</p>	<p>Is there poor contact in ECM connector?</p>	<p>Repair the poor contact in ECM connector.</p>	<p>Replace the ECM. &lt;Ref. to FU(STi)-41, Engine Control Module (ECM).&gt;</p>

# DIAGNOSTIC PROCEDURE WITH DIAGNOSTIC TROUBLE CODE (DTC)

ENGINE (DIAGNOSTICS)

## CB:DTC P0851 — NEUTRAL SWITCH INPUT CIRCUIT LOW —

### • DTC DETECTING CONDITION:

- Two consecutive driving cycles with fault
- GENERAL DESCRIPTION <Ref. to GD(STi)-192, DTC P0851 — NEUTRAL SWITCH INPUT CIRCUIT LOW —, Diagnostic Trouble Code (DTC) Detecting Criteria.>

### • TROUBLE SYMPTOM:

- Erroneous idling

### CAUTION:

After repair or replacement of faulty parts, conduct Clear Memory Mode <Ref. to EN(STi)-42, OPERATION, Clear Memory Mode.> and Inspection Mode <Ref. to EN(STi)-35, OPERATION, Inspection Mode.>.

### • WIRING DIAGRAM:

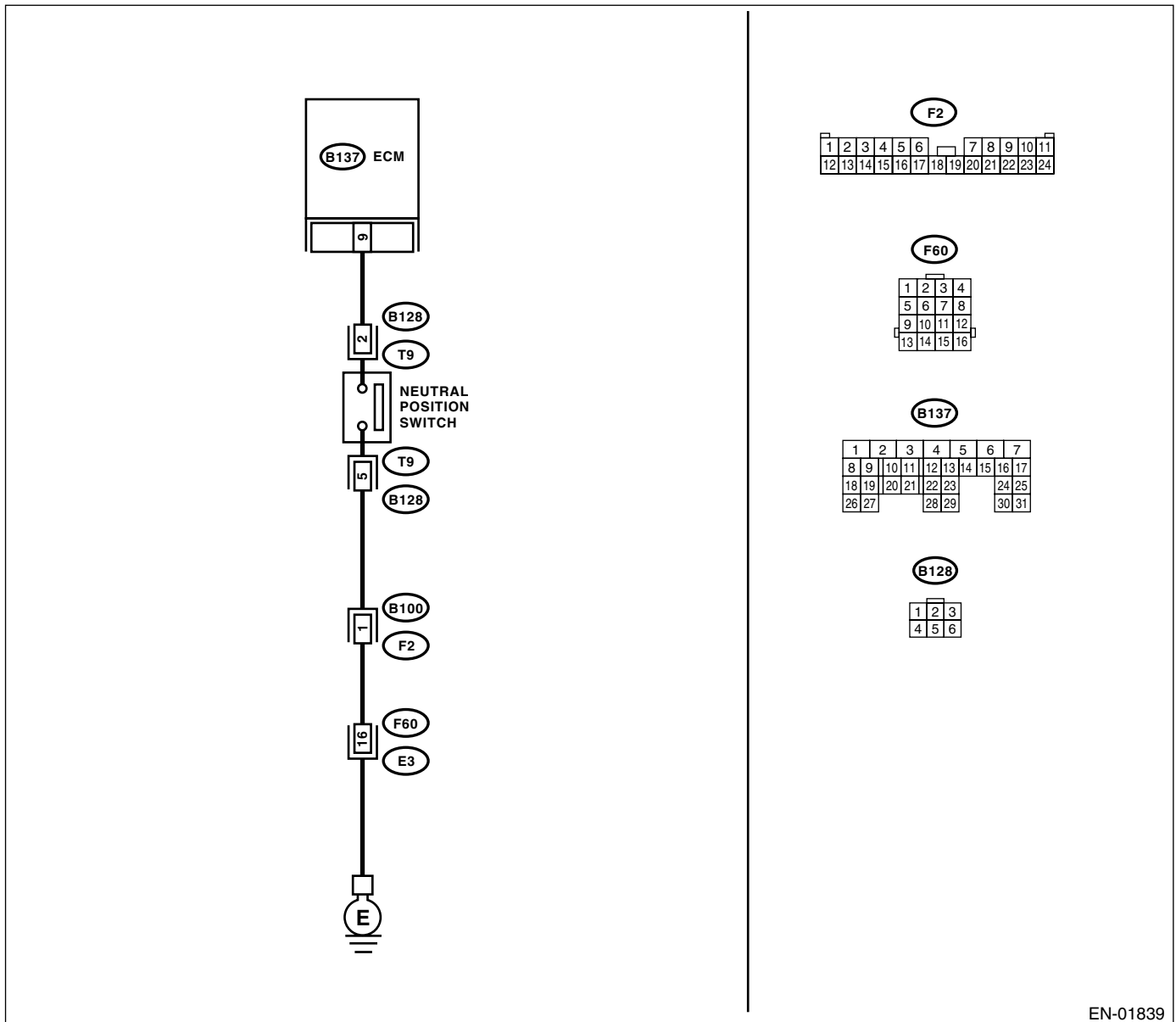

EN-01839

# DIAGNOSTIC PROCEDURE WITH DIAGNOSTIC TROUBLE CODE (DTC)

ENGINE (DIAGNOSTICS)

Step	Check	Yes	No
<b>1 CHECK INPUT SIGNAL FOR ECM.</b> 1) Turn the ignition switch to ON. 2) Place the shift lever in neutral. 3) Measure the voltage between ECM and chassis ground. <i>Connector &amp; terminal</i> <i>(B137) No. 9 (+) — Chassis ground (-):</i>	Is the voltage more than 10 V?	Go to step 2.	Go to step 4.
<b>2 CHECK INPUT SIGNAL FOR ECM.</b> 1) Place the shift lever in a position except for neutral. 2) Measure the voltage between ECM and chassis ground. <i>Connector &amp; terminal</i> <i>(B137) No. 9 (+) — Chassis ground (-):</i>	Is the voltage less than 1 V?	Go to step 3.	Go to step 4.
<b>3 CHECK POOR CONTACT.</b> Check poor contact in ECM connector.	Is there poor contact in ECM connector?	Repair poor contact in ECM connector.	Contact your SOA Service Center.
<b>4 CHECK NEUTRAL POSITION SWITCH.</b> 1) Turn the ignition switch to OFF. 2) Disconnect the connector from transmission harness. 3) Place the shift lever in neutral. 4) Measure the resistance between transmission harness and connector terminals. <i>Connector &amp; terminal</i> <i>(T9) No. 2 — No. 5:</i>	Is the resistance more than 1 M $\Omega$ ?	Go to step 5.	Repair short circuit in transmission harness or replace neutral position switch.
<b>5 CHECK NEUTRAL POSITION SWITCH.</b> 1) Place the shift lever in a position except for neutral. 2) Measure the resistance between transmission harness connector terminals.	Is the resistance less than 1 $\Omega$ ?	Go to step 6.	Repair short circuit in transmission harness or replace neutral position switch.
<b>6 CHECK HARNESS BETWEEN ECM AND NEUTRAL POSITION SWITCH CONNECTOR.</b> Measure the resistance between ECM and chassis ground. <i>Connector &amp; terminal</i> <i>(B137) No. 9 — Chassis ground:</i>	Is the resistance more than 1 M $\Omega$ ?	Go to step 7.	Repair ground short circuit in harness between ECM and transmission harness connector.
<b>7 CHECK HARNESS BETWEEN ECM AND NEUTRAL POSITION SWITCH CONNECTOR.</b> 1) Disconnect the connector from ECM. 2) Measure the resistance of harness between ECM and transmission harness connector. <i>Connector &amp; terminal</i> <i>(B137) No. 9 — (B128) No. 2:</i>	Is the resistance less than 1 $\Omega$ ?	Go to step 8.	Repair open circuit in harness between ECM and transmission harness connector.
<b>8 CHECK HARNESS BETWEEN ECM AND NEUTRAL POSITION SWITCH CONNECTOR.</b> Measure the resistance of harness between transmission harness connector and engine ground. <i>Connector &amp; terminal</i> <i>(B128) No. 2 — Engine ground:</i>	Is the resistance less than 5 $\Omega$ ?	Go to step 9.	Repair open circuit between transmission harness connector and engine ground terminal.
<b>9 CHECK POOR CONTACT.</b> Check poor contact in transmission harness connector.	Is there poor contact in transmission harness connector?	Repair poor contact in transmission harness connector.	Contact your SOA Service Center.

# DIAGNOSTIC PROCEDURE WITH DIAGNOSTIC TROUBLE CODE (DTC)

ENGINE (DIAGNOSTICS)

## CC:DTC P0852 — NEUTRAL SWITCH INPUT CIRCUIT HIGH —

### • DTC DETECTING CONDITION:

- Two consecutive driving cycles with fault
- GENERAL DESCRIPTION <Ref. to GD(STi)-193, DTC P0852 — NEUTRAL SWITCH INPUT CIRCUIT HIGH —, Diagnostic Trouble Code (DTC) Detecting Criteria.>

### • TROUBLE SYMPTOM:

- Erroneous idling

### CAUTION:

After repair or replacement of faulty parts, conduct Clear Memory Mode <Ref. to EN(STi)-42, OPERATION, Clear Memory Mode.> and Inspection Mode <Ref. to EN(STi)-35, OPERATION, Inspection Mode.>.

### • WIRING DIAGRAM:

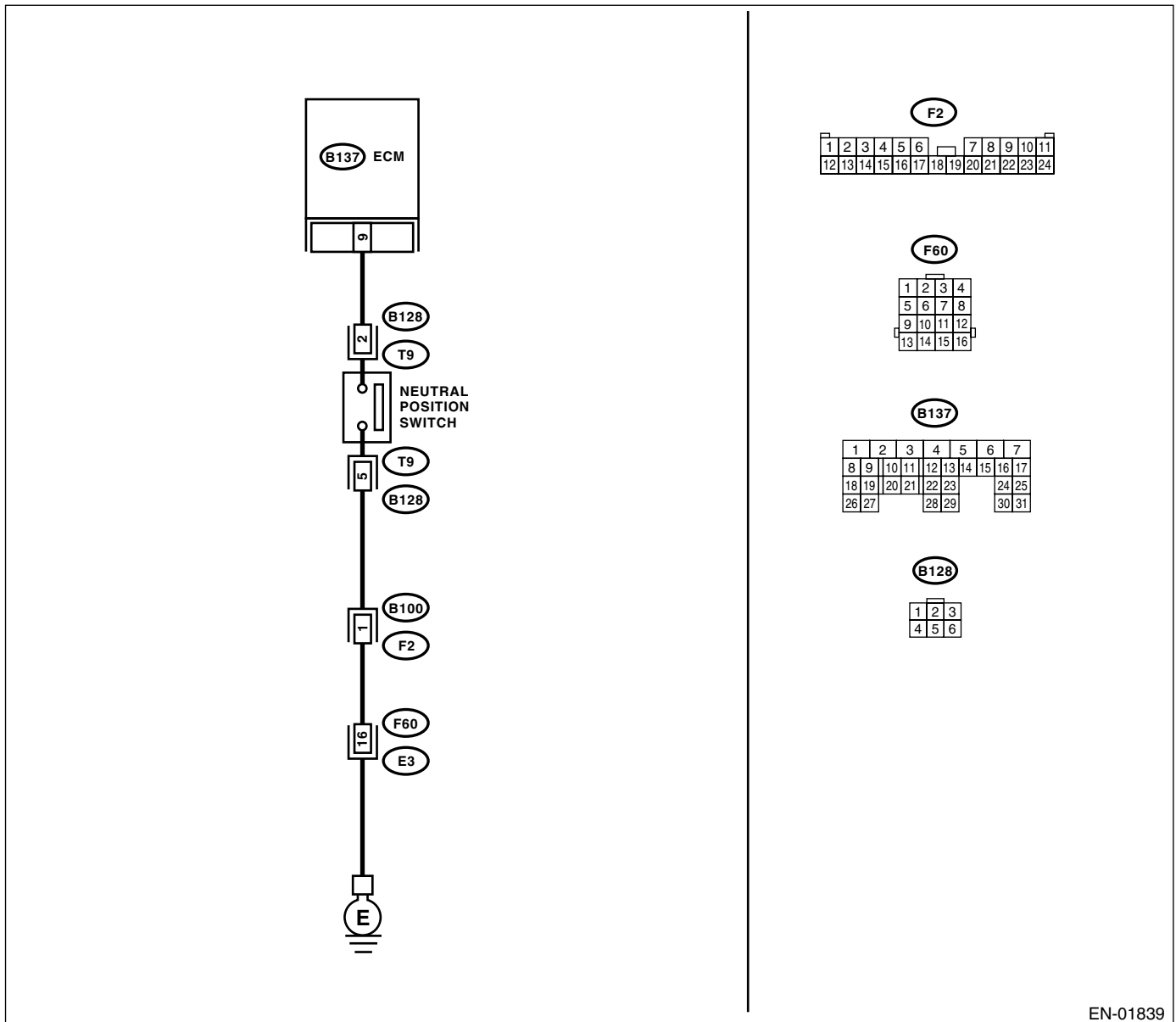

EN-01839

# DIAGNOSTIC PROCEDURE WITH DIAGNOSTIC TROUBLE CODE (DTC)

## ENGINE (DIAGNOSTICS)

Step	Check	Yes	No
<b>1 CHECK INPUT SIGNAL FOR ECM.</b> 1) Turn the ignition switch to ON. 2) Set the shift lever to except neutral position. 3) Measure the voltage between ECM and chassis ground. <i>Connector &amp; terminal</i> <i>(B137) No. 9 (+) — Chassis ground (-):</i>	Is the voltage less than 1 V?	Go to step 2.	Go to step 4.
<b>2 CHECK INPUT SIGNAL FOR ECM.</b> 1) Set the shift lever to neutral position. 2) Measure the voltage between ECM and chassis ground. <i>Connector &amp; terminal</i> <i>(B137) No. 9 (+) — Chassis ground (-):</i>	Is the voltage more than 10 V?	Go to step 3.	Go to step 4.
<b>3 CHECK POOR CONTACT.</b> Check poor contact in ECM connector.	Is there poor contact in ECM connector?	Repair the poor contact in ECM connector.	Contact your SOA Service Center.
<b>4 CHECK INPUT SIGNAL FOR ECM.</b> 1) Disconnect ECM connector from ECM. 2) Measure the voltage between ECM and chassis ground. <i>Connector &amp; terminal</i> <i>(B137) No. 9 (+) — Chassis ground (-):</i>	Is the voltage more than 10 V?	Repair the battery short circuit in harness between ECM and transmission connector.	Go to step 5.
<b>5 CHECK HARNESS BETWEEN ECM AND TRANSMISSION HARNESS CONNECTOR.</b> 1) Turn the ignition switch to OFF. 2) Disconnect the connectors from ECM and transmission harness connector (T9). 3) Measure the resistance of harness between ECM and neutral switch connector. <i>Connector &amp; terminal</i> <i>(B137) No. 9 — (B128) No. 2:</i>	Is the resistance less than 1 $\Omega$ ?	Go to step 6.	Repair the harness and connector. NOTE: In this case, repair the following: <ul style="list-style-type: none"> <li>• Open circuit in harness between ECM and transmission harness</li> <li>• Poor contact in transmission harness connector</li> <li>• Poor contact in ECM connector</li> </ul>
<b>6 CHECK NEUTRAL POSITION SWITCH GROUND LINE.</b> Measure the resistance of harness between transmission harness connector and engine ground. <i>Connector &amp; terminal</i> <i>(B128) No. 5 — Engine ground:</i>	Is the resistance less than 5 $\Omega$ ?	Go to step 7.	Repair the open circuit in harness of neutral position switch ground line.
<b>7 CHECK NEUTRAL POSITION SWITCH.</b> 1) Set the shift lever to except neutral position. 2) Measure the resistance between transmission harness connector receptacle's terminals. <i>Terminals</i> <i>No. 2 — No. 5:</i>	Is the resistance less than 1 $\Omega$ ?	Go to step 8.	Replace the neutral position switch.
<b>8 CHECK POOR CONTACT.</b> Check poor contact in the transmission harness connector.	Is there poor contact in the transmission harness connector?	Repair poor contact in transmission harness connector.	Contact your SOA Service Center.

# DIAGNOSTIC PROCEDURE WITH DIAGNOSTIC TROUBLE CODE (DTC)

ENGINE (DIAGNOSTICS)

## CD: DTC P1086 — TUMBLE GENERATED VALVE POSITION SENSOR 2 CIRCUIT LOW —

### • DTC DETECTING CONDITION:

- Immediately at fault recognition
- GENERAL DESCRIPTION <Ref. to GD(STi)-194, DTC P1086 — TUMBLE GENERATED VALVE POSITION SENSOR 2 CIRCUIT LOW —, Diagnostic Trouble Code (DTC) Detecting Criteria.>

### • TROUBLE SYMPTOM:

- Erroneous idling
- Engine stalls.
- Poor driving performance

### CAUTION:

After repair or replacement of faulty parts, conduct Clear Memory Mode <Ref. to EN(STi)-42, OPERATION, Clear Memory Mode.> and Inspection Mode <Ref. to EN(STi)-35, OPERATION, Inspection Mode.>.

### • WIRING DIAGRAM:

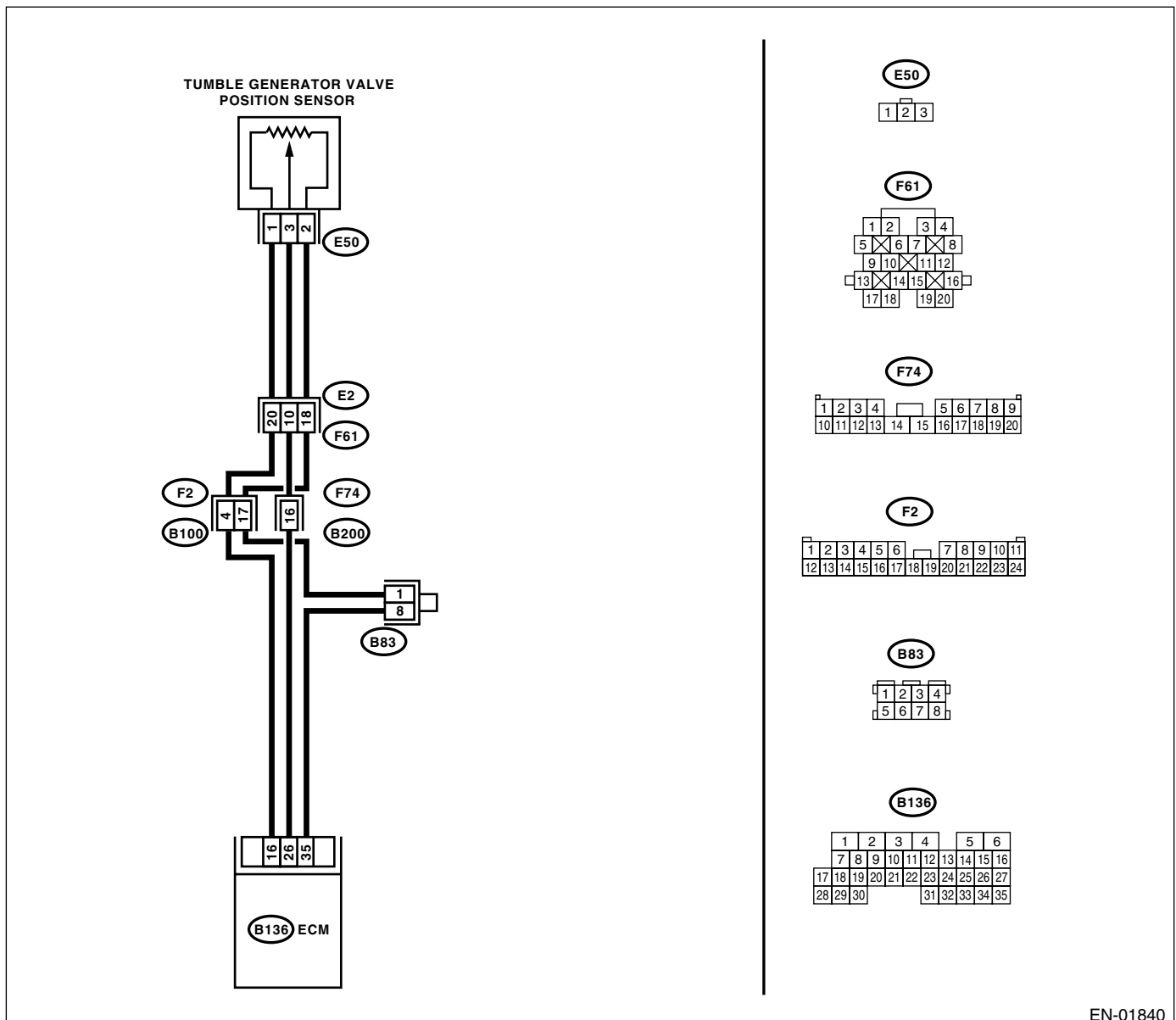

EN-01840

# DIAGNOSTIC PROCEDURE WITH DIAGNOSTIC TROUBLE CODE (DTC)

ENGINE (DIAGNOSTICS)

Step	Check	Yes	No
<p><b>1</b>      <b>CHECK CURRENT DATA.</b>                      1) Start the engine.                      2) Read the data of throttle position sensor signal using Subaru Select Monitor or OBD-II general scan tool.</p> <p>NOTE:                      • Subaru Select Monitor                      For detailed operation procedure, refer to the "READ CURRENT DATA FOR ENGINE".                      &lt;Ref. to EN(STi)-28, Subaru Select Monitor.&gt;                      • OBD-II general scan tool                      For detailed operation procedures, refer to the OBD-II General Scan Tool Instruction Manual.</p>	<p>Is the voltage less than 0.1 V?</p>	<p>Go to step 2.</p>	<p>Even if malfunction indicator light lights up, the circuit has returned to a normal condition at this time. A temporary poor contact of the connector may be the cause.</p> <p>NOTE:                      In this case, repair the following:                      • Poor contact in throttle position sensor connector                      • Poor contact in ECM connector                      • Poor contact in coupling connector</p>
<p><b>2</b>      <b>CHECK INPUT SIGNAL FOR ECM.</b>                      Measure the voltage between ECM connector and chassis ground while tumble generator valve is fully closed.</p> <p><b>Connector &amp; terminal</b>  <b>(B136) No. 16 (+) — Chassis ground (-):</b></p>	<p>Is the voltage more than 4.5 V?</p>	<p>Go to step 4.</p>	<p>Go to step 3.</p>
<p><b>3</b>      <b>CHECK INPUT SIGNAL FOR ECM.</b>                      Measure the voltage between ECM connector and chassis ground.</p> <p><b>Connector &amp; terminal</b>  <b>(B136) No. 16 (+) — Chassis ground (-):</b></p>	<p>Shake the ECM harness and connector, while monitoring value of voltage meter. Does the voltage change?</p>	<p>Repair the poor contact in ECM connector.</p>	<p>Contact your SOA Service Center.</p> <p>NOTE:                      Inspection by DTM is required, because probable cause is deterioration of multiple parts.</p>
<p><b>4</b>      <b>CHECK INPUT SIGNAL FOR ECM.</b>                      Measure the voltage between ECM connector and chassis ground.</p> <p><b>Connector &amp; terminal</b>  <b>(B136) No. 26 (+) — Chassis ground (-):</b></p>	<p>Is the voltage less than 0.1 V?</p>	<p>Go to step 6.</p>	<p>Go to step 5.</p>
<p><b>5</b>      <b>CHECK INPUT SIGNAL FOR ECM. (USING SUBARU SELECT MONITOR)</b>                      Measure the voltage between ECM connector and chassis ground.</p>	<p>Shake the ECM harness and connector, while monitoring value of Subaru Select Monitor. Does the voltage change?</p>	<p>Repair the poor contact in ECM connector.</p>	<p>Go to step 6.</p>

# DIAGNOSTIC PROCEDURE WITH DIAGNOSTIC TROUBLE CODE (DTC)

ENGINE (DIAGNOSTICS)

Step	Check	Yes	No
<p><b>6 CHECK HARNESS BETWEEN ECM AND TUMBLE GENERATOR VALVE POSITION SENSOR CONNECTOR.</b></p> <p>1) Turn the ignition switch to OFF.                      2) Disconnect the connectors from tumble generator valve position sensor.                      3) Turn the ignition switch to ON.                      4) Measure the voltage between tumble generator valve position sensor connector and engine ground.</p> <p><b>Connector &amp; terminal</b>  <b>(E50) No. 1 (+) — Engine ground (-):</b></p>	<p>Is the voltage more than 4.5 V?</p>	<p>Go to step 7.</p>	<p>Repair the harness and connector.</p> <p><b>NOTE:</b>                      In this case, repair the following:</p> <ul style="list-style-type: none"> <li>• Open circuit in harness between tumble generator valve position sensor and ECM connector</li> <li>• Poor contact in tumble generator valve position sensor connector</li> <li>• Poor contact in ECM connector</li> <li>• Poor contact in coupling connector</li> <li>• Poor contact in joint connector</li> </ul>
<p><b>7 CHECK HARNESS BETWEEN ECM AND TUMBLE GENERATOR VALVE POSITION SENSOR CONNECTOR.</b></p> <p>1) Turn the ignition switch to OFF.                      2) Measure the resistance of harness between ECM connector and tumble generator valve position sensor connector.</p> <p><b>Connector &amp; terminal</b>  <b>(B136) No. 26 — (E50) No. 3:</b></p>	<p>Is the resistance less than 1 <math>\Omega</math>?</p>	<p>Go to step 8.</p>	<p>Repair the harness and connector.</p> <p><b>NOTE:</b>                      In this case, repair the following:</p> <ul style="list-style-type: none"> <li>• Open circuit in harness between tumble generator valve position sensor and ECM connector</li> <li>• Poor contact in ECM connector</li> <li>• Poor contact in tumble generator valve position sensor connector</li> <li>• Poor contact in coupling connector</li> </ul>
<p><b>8 CHECK HARNESS BETWEEN ECM AND TUMBLE GENERATOR VALVE POSITION SENSOR CONNECTOR.</b></p> <p>Measure the resistance of harness between tumble generator valve position sensor connector and engine ground.</p> <p><b>Connector &amp; terminal</b>  <b>(E50) No. 3 — Engine ground:</b></p>	<p>Is the resistance more than 1 M<math>\Omega</math>?</p>	<p>Go to step 9.</p>	<p>Repair the ground short circuit in harness between tumble generator valve position sensor and ECM connector.</p>
<p><b>9 CHECK POOR CONTACT.</b></p> <p>Check poor contact in tumble generator valve position sensor connector.</p>	<p>Is there poor contact in tumble generator valve position sensor connector?</p>	<p>Repair the poor contact in tumble generator valve position sensor connector.</p>	<p>Replace the tumble generator valve assembly.                      &lt;Ref. to FU(STi)-34, Tumble Generator Valve Assembly.&gt;</p>



# DIAGNOSTIC PROCEDURE WITH DIAGNOSTIC TROUBLE CODE (DTC)

ENGINE (DIAGNOSTICS)

## CE:DTC P1087 — TUMBLE GENERATED VALVE POSITION SENSOR 2 CIRCUIT HIGH —

### • DTC DETECTING CONDITION:

- Immediately at fault recognition
- GENERAL DESCRIPTION <Ref. to GD(STi)-196, DTC P1087 — TUMBLE GENERATED VALVE POSITION SENSOR 2 CIRCUIT HIGH —, Diagnostic Trouble Code (DTC) Detecting Criteria.>

### • TROUBLE SYMPTOM:

- Erroneous idling
- Engine stalls.
- Poor driving performance

### CAUTION:

After repair or replacement of faulty parts, conduct Clear Memory Mode <Ref. to EN(STi)-42, OPERATION, Clear Memory Mode.> and Inspection Mode <Ref. to EN(STi)-35, OPERATION, Inspection Mode.>.

### • WIRING DIAGRAM:

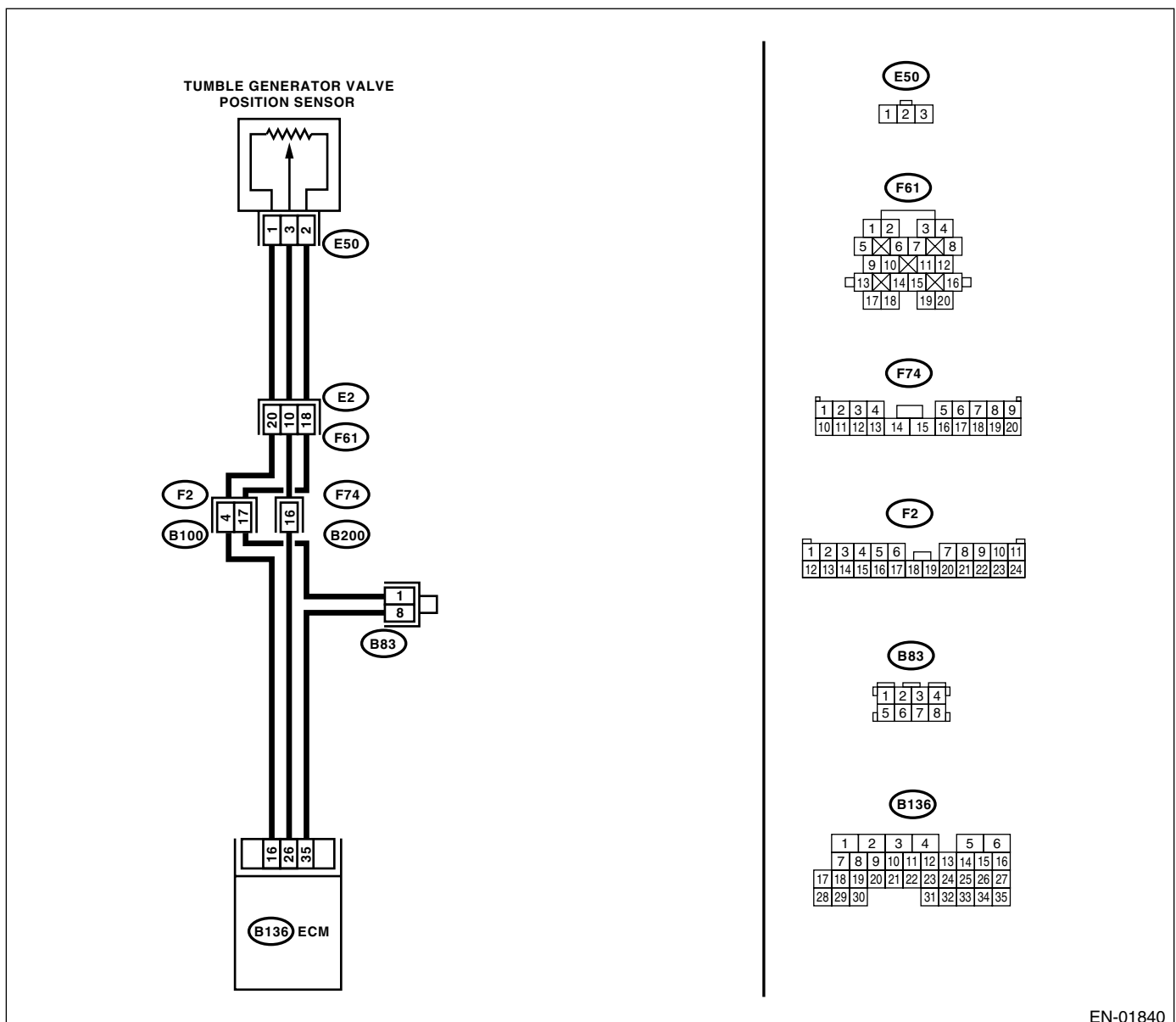

EN-01840

# DIAGNOSTIC PROCEDURE WITH DIAGNOSTIC TROUBLE CODE (DTC)

ENGINE (DIAGNOSTICS)

Step	Check	Yes	No
<p><b>1</b></p> <p><b>CHECK CURRENT DATA.</b></p> <p>1)Start the engine. 2)Read the data of throttle position sensor signal using Subaru Select Monitor or OBD-II general scan tool.</p> <p>NOTE: •Subaru Select Monitor For detailed operation procedure, refer to the "READ CURRENT DATA FOR ENGINE". &lt;Ref. to EN(STi)-28, Subaru Select Monitor.&gt; •OBD-II general scan tool For detailed operation procedures, refer to the OBD-II General Scan Tool Instruction Manual.</p>	<p>Is the voltage more than 4.9 V?</p>	<p>Go to step 2.</p>	<p>Even if malfunction indicator light lights up, the circuit has returned to a normal condition at this time. A temporary poor contact of the connector may be the cause.</p> <p>NOTE: In this case, repair the following:</p> <ul style="list-style-type: none"> <li>• Poor contact in tumble generator valve position sensor connector</li> <li>• Poor contact in ECM connector</li> <li>• Poor contact in coupling connector</li> </ul>
<p><b>2</b></p> <p><b>CHECK HARNESS BETWEEN TUMBLE GENERATOR VALVE POSITION SENSOR AND ECM CONNECTOR.</b></p> <p>1)Turn the ignition switch to OFF. 2)Disconnect the connector from throttle position sensor. 3)Measure the resistance of harness between throttle position sensor connector and engine ground.</p> <p><b>Connector &amp; terminal</b> <b>(E50) No. 2 — Engine ground:</b></p>	<p>Is the resistance less than 5 Ω?</p>	<p>Go to step 3.</p>	<p>Repair the harness and connector.</p> <p>NOTE: In this case, repair the following:</p> <ul style="list-style-type: none"> <li>• Open circuit in harness between tumble generator valve position sensor and ECM connector</li> <li>• Poor contact in coupling connector</li> <li>• Poor contact in joint connector</li> </ul>
<p><b>3</b></p> <p><b>CHECK HARNESS BETWEEN THROTTLE POSITION SENSOR AND ECM CONNECTOR.</b></p> <p>1)Turn the ignition switch to ON. 2)Measure the voltage between throttle position sensor connector and engine ground.</p> <p><b>Connector &amp; terminal</b> <b>(E50) No. 3 (+) — Engine ground (-):</b></p>	<p>Is the voltage more than 4.9 V?</p>	<p>Repair the battery short circuit in harness between tumble generator valve position sensor and ECM connector. After repair, replace the ECM. &lt;Ref. to FU(STi)-41, Engine Control Module (ECM).&gt;</p>	<p>Replace the tumble generator valve assembly. &lt;Ref. to FU(STi)-34, Tumble Generator Valve Assembly.&gt;</p>

# DIAGNOSTIC PROCEDURE WITH DIAGNOSTIC TROUBLE CODE (DTC)

ENGINE (DIAGNOSTICS)

## CF: DTC P1088 — TUMBLE GENERATED VALVE POSITION SENSOR 1 CIRCUIT LOW —

### • DTC DETECTING CONDITION:

- Immediately at fault recognition
- GENERAL DESCRIPTION <Ref. to GD(STi)-198, DTC P1088 — TUMBLE GENERATED VALVE POSITION SENSOR 1 CIRCUIT LOW —, Diagnostic Trouble Code (DTC) Detecting Criteria.>

### • TROUBLE SYMPTOM:

- Erroneous idling
- Engine stalls.
- Poor driving performance

### CAUTION:

After repair or replacement of faulty parts, conduct Clear Memory Mode <Ref. to EN(STi)-42, OPERATION, Clear Memory Mode.> and Inspection Mode <Ref. to EN(STi)-35, OPERATION, Inspection Mode.>.

### • WIRING DIAGRAM:

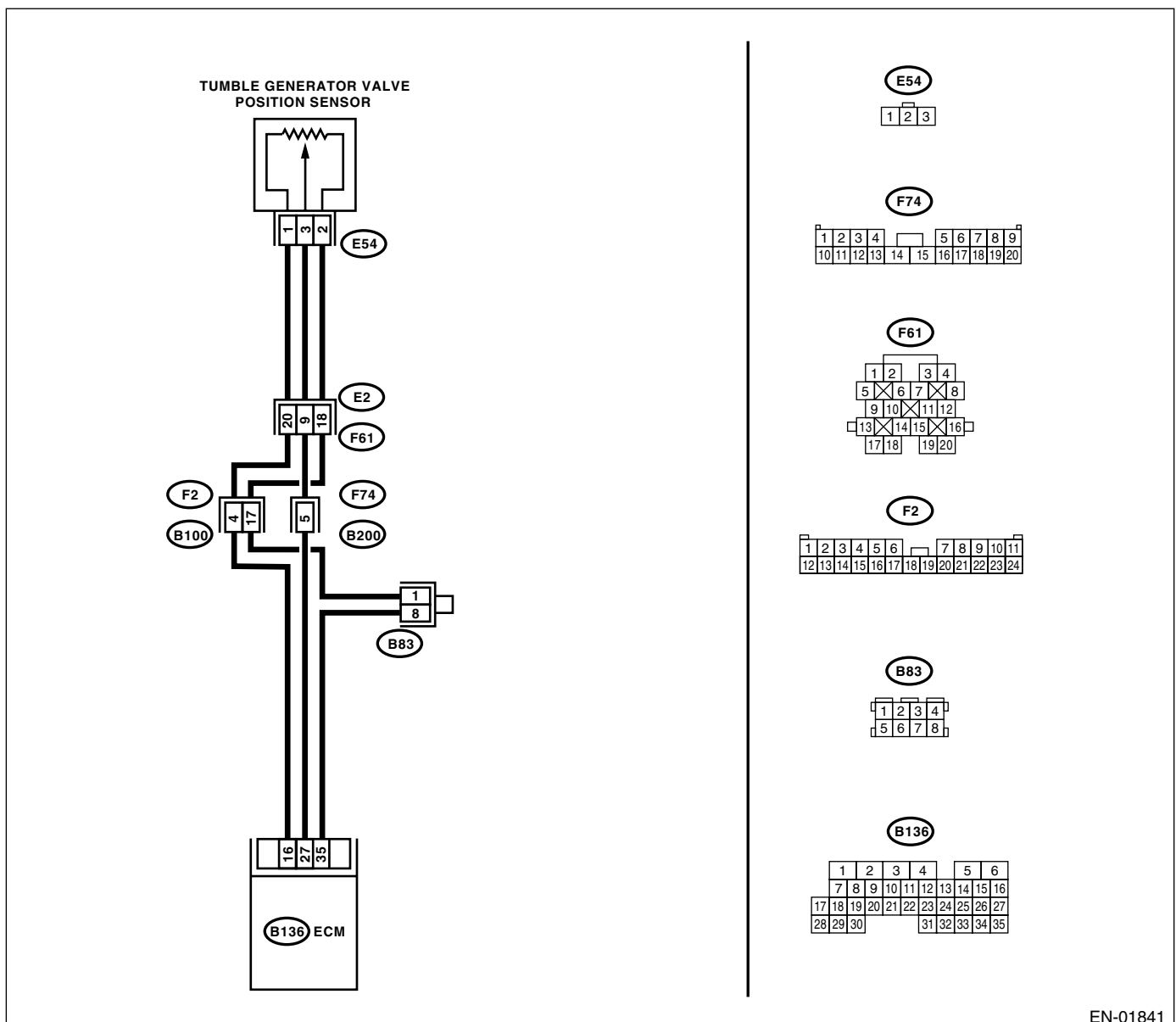

EN-01841

# DIAGNOSTIC PROCEDURE WITH DIAGNOSTIC TROUBLE CODE (DTC)

## ENGINE (DIAGNOSTICS)

Step	Check	Yes	No
<b>1</b> <b>CHECK CURRENT DATA.</b> 1)Start the engine. 2)Read the data of tumble generator valve position sensor signal using Subaru Select Monitor or OBD-II general scan tool.  NOTE: •Subaru Select Monitor For detailed operation procedure, refer to the "READ CURRENT DATA FOR ENGINE". <Ref. to EN(STi)-28, Subaru Select Monitor.> •OBD-II general scan tool For detailed operation procedures, refer to the OBD-II General Scan Tool Instruction Manual.	Is the voltage less than 0.1 V?	Go to step 2.	Even if malfunction indicator light lights up, the circuit has returned to a normal condition at this time. A temporary poor contact of the connector may be the cause.  NOTE: In this case, repair the following: • Poor contact in tumble generator valve position sensor connector • Poor contact in ECM connector • Poor contact in coupling connector
<b>2</b> <b>CHECK INPUT SIGNAL FOR ECM.</b> Measure the voltage between ECM connector and chassis ground while throttle valve is fully closed.  <i>Connector &amp; terminal</i> <i>(B136) No. 16 (+) — Chassis ground (-):</i>	Is the voltage more than 4.5 V?	Go to step 4.	Go to step 3.
<b>3</b> <b>CHECK INPUT SIGNAL FOR ECM.</b> Measure the voltage between ECM connector and chassis ground.  <i>Connector &amp; terminal</i> <i>(B136) No. 16 (+) — Chassis ground (-):</i>	Shake the ECM harness and connector, while monitoring value of voltage meter. Does the voltage change?	Repair the poor contact in ECM connector.	Contact your SOA Service Center.  NOTE: Inspection by DTM is required, because probable cause is deterioration of multiple parts.
<b>4</b> <b>CHECK INPUT SIGNAL FOR ECM.</b> Measure the voltage between ECM connector and chassis ground.  <i>Connector &amp; terminal</i> <i>(B136) No. 27 (+) — Chassis ground (-):</i>	Is the voltage less than 0.1 V?	Go to step 6.	Go to step 5.
<b>5</b> <b>CHECK INPUT SIGNAL FOR ECM. (USING SUBARU SELECT MONITOR)</b> Measure the voltage between ECM connector and chassis ground.	Shake the ECM harness and connector, while monitoring value of Subaru Select Monitor. Does the voltage change?	Repair the poor contact in ECM connector.	Go to step 6.

# DIAGNOSTIC PROCEDURE WITH DIAGNOSTIC TROUBLE CODE (DTC)

## ENGINE (DIAGNOSTICS)

Step	Check	Yes	No
<p><b>6</b></p> <p><b>CHECK HARNESS BETWEEN ECM AND TUMBLE GENERATOR VALVE POSITION SENSOR CONNECTOR.</b></p> <p>1) Turn the ignition switch to OFF.                      2) Disconnect the connectors from throttle position sensor.                      3) Turn the ignition switch to ON.                      4) Measure the voltage between throttle position sensor connector and engine ground.</p> <p><b>Connector &amp; terminal</b>  <b>(E54) No. 1 (+) — Engine ground (-):</b></p>	<p>Is the voltage more than 4.5 V?</p>	<p>Go to step 7.</p>	<p>Repair the harness and connector.</p> <p><b>NOTE:</b>                      In this case, repair the following:</p> <ul style="list-style-type: none"> <li>• Open circuit in harness between tumble generator valve position sensor and ECM connector</li> <li>• Poor contact in throttle position sensor connector</li> <li>• Poor contact in ECM connector</li> <li>• Poor contact in coupling connector</li> <li>• Poor contact in joint connector</li> </ul>
<p><b>7</b></p> <p><b>CHECK HARNESS BETWEEN ECM AND TUMBLE GENERATOR VALVE POSITION SENSOR CONNECTOR.</b></p> <p>1) Turn the ignition switch to OFF.                      2) Measure the resistance of harness between ECM connector and throttle position sensor connector.</p> <p><b>Connector &amp; terminal</b>  <b>(B136) No. 27 — (E54) No. 3:</b></p>	<p>Is the resistance less than 1 <math>\Omega</math>?</p>	<p>Go to step 8.</p>	<p>Repair the harness and connector.</p> <p><b>NOTE:</b>                      In this case, repair the following:</p> <ul style="list-style-type: none"> <li>• Open circuit in harness between tumble generator valve position sensor and ECM connector</li> <li>• Poor contact in ECM connector</li> <li>• Poor contact in tumble generator valve position sensor connector</li> <li>• Poor contact in coupling connector</li> </ul>
<p><b>8</b></p> <p><b>CHECK HARNESS BETWEEN ECM AND THROTTLE POSITION SENSOR CONNECTOR.</b></p> <p>Measure the resistance of harness between tumble generator valve position sensor connector and engine ground.</p> <p><b>Connector &amp; terminal</b>  <b>(E54) No. 3 — Engine ground:</b></p>	<p>Is the resistance more than 1 M<math>\Omega</math>?</p>	<p>Go to step 9.</p>	<p>Repair the ground short circuit in harness between tumble generator valve position sensor and ECM connector.</p>
<p><b>9</b></p> <p><b>CHECK POOR CONTACT.</b></p> <p>Check poor contact in tumble generator valve position sensor connector.</p>	<p>Is there poor contact in tumble generator valve position sensor connector?</p>	<p>Repair the poor contact in tumble generator valve position sensor connector.</p>	<p>Replace the tumble generator valve assembly.                      &lt;Ref. to FU(STi)-34, Tumble Generator Valve Assembly.&gt;</p>

# DIAGNOSTIC PROCEDURE WITH DIAGNOSTIC TROUBLE CODE (DTC)

## ENGINE (DIAGNOSTICS)

### CG:DTC P1089 — TUMBLE GENERATED VALVE POSITION SENSOR 1 CIRCUIT HIGH —

**DTC DETECTING CONDITION:**

- Immediately at fault recognition
- GENERAL DESCRIPTION <Ref. to GD(STi)-200, DTC P1089 — TUMBLE GENERATED VALVE POSITION SENSOR 1 CIRCUIT HIGH —, Diagnostic Trouble Code (DTC) Detecting Criteria.>

**TROUBLE SYMPTOM:**

- Erroneous idling
- Engine stalls.
- Poor driving performance

**CAUTION:**

After repair or replacement of faulty parts, conduct Clear Memory Mode <Ref. to EN(STi)-42, OPERATION, Clear Memory Mode.> and Inspection Mode <Ref. to EN(STi)-35, OPERATION, Inspection Mode.>.

**WIRING DIAGRAM:**

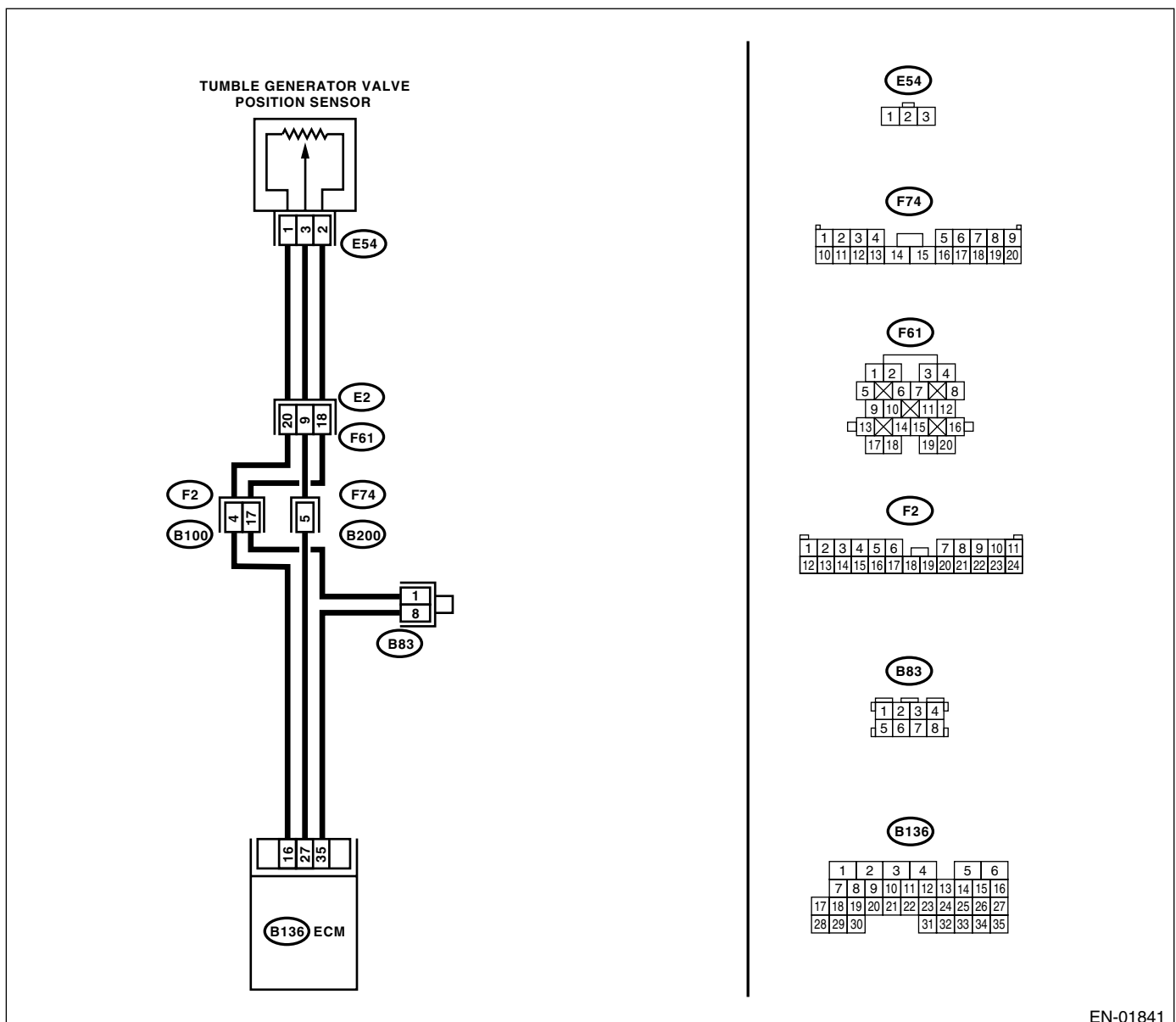

EN-01841

# DIAGNOSTIC PROCEDURE WITH DIAGNOSTIC TROUBLE CODE (DTC)

ENGINE (DIAGNOSTICS)

Step	Check	Yes	No
<p><b>1</b></p> <p><b>CHECK CURRENT DATA.</b></p> <p>1)Start the engine. 2)Read the data of tumble generator valve position sensor signal using Subaru Select Monitor or OBD-II general scan tool.</p> <p>NOTE: •Subaru Select Monitor For detailed operation procedure, refer to the "READ CURRENT DATA FOR ENGINE". &lt;Ref. to EN(STi)-28, Subaru Select Monitor.&gt; •OBD-II general scan tool For detailed operation procedures, refer to the OBD-II General Scan Tool Instruction Manual.</p>	<p>Is the voltage more than 4.9 V?</p>	<p>Go to step 2.</p>	<p>Even if malfunction indicator light lights up, the circuit has returned to a normal condition at this time. A temporary poor contact of the connector may be the cause.</p> <p>NOTE: In this case, repair the following:</p> <ul style="list-style-type: none"> <li>• Poor contact in tumble generator valve position sensor connector</li> <li>• Poor contact in ECM connector</li> <li>• Poor contact in coupling connector</li> </ul>
<p><b>2</b></p> <p><b>CHECK HARNESS BETWEEN TUMBLE GENERATOR VALVE POSITION SENSOR AND ECM CONNECTOR.</b></p> <p>1)Turn the ignition switch to OFF. 2)Disconnect the connector from throttle position sensor. 3)Measure the resistance of harness between tumble generator valve position sensor connector and engine ground.</p> <p><b>Connector &amp; terminal</b> <b>(E54) No. 2 — Engine ground:</b></p>	<p>Is the resistance less than 5 Ω?</p>	<p>Go to step 3.</p>	<p>Repair the harness and connector.</p> <p>NOTE: In this case, repair the following:</p> <ul style="list-style-type: none"> <li>• Open circuit in harness between tumble generator valve position sensor and ECM connector</li> <li>• Poor contact in coupling connector</li> <li>• Poor contact in joint connector</li> </ul>
<p><b>3</b></p> <p><b>CHECK HARNESS BETWEEN TUMBLE GENERATOR VALVE POSITION SENSOR AND ECM CONNECTOR.</b></p> <p>1)Turn the ignition switch to ON. 2)Measure the voltage between throttle position sensor connector and engine ground.</p> <p><b>Connector &amp; terminal</b> <b>(E54) No. 3 (+) — Engine ground (-):</b></p>	<p>Is the voltage more than 4.9 V?</p>	<p>Repair the battery short circuit in harness between tumble generator valve position sensor and ECM connector. After repair, replace the ECM. &lt;Ref. to FU(STi)-41, Engine Control Module (ECM).&gt;</p>	<p>Replace the tumble generator valve assembly. &lt;Ref. to FU(STi)-34, Tumble Generator Valve Assembly.&gt;</p>

# DIAGNOSTIC PROCEDURE WITH DIAGNOSTIC TROUBLE CODE (DTC)

ENGINE (DIAGNOSTICS)

## CH: DTC P1090 — TUMBLE GENERATED VALVE SYSTEM 1 (VALVE OPEN) —

### • DTC DETECTING CONDITION:

- Immediately at fault recognition
- GENERAL DESCRIPTION <Ref. to GD(STi)-202, DTC P1090 — TUMBLE GENERATED VALVE SYSTEM 1 (VALVE OPEN) —, Diagnostic Trouble Code (DTC) Detecting Criteria.>

### CAUTION:

After repair or replacement of faulty parts, conduct Clear Memory Mode <Ref. to EN(STi)-42, OPERATION, Clear Memory Mode.> and Inspection Mode <Ref. to EN(STi)-35, OPERATION, Inspection Mode.>.

Step	Check	Yes	No
1 <b>CHECK ANY OTHER DTC ON DISPLAY.</b>	Is any other DTC displayed?	Inspect the relevant DTC using "List of Diagnostic Trouble Code (DTC)". <Ref. to EN(STi)-66, List of Diagnostic Trouble Code (DTC).>	Go to step 2.
2 <b>CHECK TUMBLE GENERATOR VALVE RH.</b> 1) Remove the tumble generator valve assembly. 2) Check the tumble generator valve body.	Does the tumble generator valve move smoothly? (No dirt or foreign materials clogged)	Replace the tumble generator valve assembly. <Ref. to FU(STi)-34, Tumble Generator Valve Assembly.>	Clean the tumble generator valve.

## CI: DTC P1091 — TUMBLE GENERATED VALVE SYSTEM 1 (VALVE CLOSE) —

### • DTC DETECTING CONDITION:

- Immediately at fault recognition
- GENERAL DESCRIPTION <Ref. to GD(STi)-203, DTC P1091 — TUMBLE GENERATED VALVE SYSTEM 1 (VALVE CLOSE) —, Diagnostic Trouble Code (DTC) Detecting Criteria.>

### CAUTION:

After repair or replacement of faulty parts, conduct Clear Memory Mode <Ref. to EN(STi)-42, OPERATION, Clear Memory Mode.> and Inspection Mode <Ref. to EN(STi)-35, OPERATION, Inspection Mode.>.

Step	Check	Yes	No
1 <b>CHECK ANY OTHER DTC ON DISPLAY.</b>	Is any other DTC displayed?	Inspect the relevant DTC using "List of Diagnostic Trouble Code (DTC)". <Ref. to EN(STi)-66, List of Diagnostic Trouble Code (DTC).>	Go to step 2.
2 <b>CHECK TUMBLE GENERATOR VALVE RH.</b> 1) Remove the tumble generator valve assembly. 2) Check the tumble generator valve body.	Does the tumble generator valve move smoothly? (No dirt or foreign materials clogged)	Replace the tumble generator valve assembly. <Ref. to FU(STi)-34, Tumble Generator Valve Assembly.>	Clean the tumble generator valve.



# DIAGNOSTIC PROCEDURE WITH DIAGNOSTIC TROUBLE CODE (DTC)

ENGINE (DIAGNOSTICS)

## CJ:DTC P1092 — TUMBLE GENERATED VALVE SYSTEM 2 (VALVE OPEN) —

### • DTC DETECTING CONDITION:

- Immediately at fault recognition
- GENERAL DESCRIPTION <Ref. to GD(STi)-204, DTC P1092 — TUMBLE GENERATED VALVE SYSTEM 2 (VALVE OPEN) —, Diagnostic Trouble Code (DTC) Detecting Criteria.>

### CAUTION:

After repair or replacement of faulty parts, conduct Clear Memory Mode <Ref. to EN(STi)-42, OPERATION, Clear Memory Mode.> and Inspection Mode <Ref. to EN(STi)-35, OPERATION, Inspection Mode.>.

Step	Check	Yes	No
1 <b>CHECK ANY OTHER DTC ON DISPLAY.</b>	Is any other DTC displayed?	Inspect the relevant DTC using "List of Diagnostic Trouble Code (DTC)". <Ref. to EN(STi)-66, List of Diagnostic Trouble Code (DTC).>	Go to step 2.
2 <b>CHECK TUMBLE GENERATOR VALVE RH.</b> 1)Remove the tumble generator valve assembly. 2)Check the tumble generator valve body.	Does the tumble generator valve move smoothly? (No dirt or foreign materials clogged)	Replace the tumble generator valve assembly. <Ref. to FU(STi)-34, Tumble Generator Valve Assembly.>	Clean the tumble generator valve.

## CK:DTC P1093 — TUMBLE GENERATED VALVE SYSTEM 2 (VALVE CLOSE) —

### • DTC DETECTING CONDITION:

- Immediately at fault recognition
- GENERAL DESCRIPTION <Ref. to GD(STi)-205, DTC P1093 — TUMBLE GENERATED VALVE SYSTEM 2 (VALVE CLOSE) —, Diagnostic Trouble Code (DTC) Detecting Criteria.>

### CAUTION:

After repair or replacement of faulty parts, conduct Clear Memory Mode <Ref. to EN(STi)-42, OPERATION, Clear Memory Mode.> and Inspection Mode <Ref. to EN(STi)-35, OPERATION, Inspection Mode.>.

Step	Check	Yes	No
1 <b>CHECK ANY OTHER DTC ON DISPLAY.</b>	Is any other DTC displayed?	Inspect the relevant DTC using "List of Diagnostic Trouble Code (DTC)". <Ref. to EN(STi)-66, List of Diagnostic Trouble Code (DTC).>	Go to step 2.
2 <b>CHECK TUMBLE GENERATOR VALVE RH.</b> 1)Remove the tumble generator valve assembly. 2)Check the tumble generator valve body.	Does the tumble generator valve move smoothly? (No dirt or foreign materials clogged)	Replace the tumble generator valve assembly. <Ref. to FU(STi)-34, Tumble Generator Valve Assembly.>	Clean the tumble generator valve.

# DIAGNOSTIC PROCEDURE WITH DIAGNOSTIC TROUBLE CODE (DTC)

ENGINE (DIAGNOSTICS)

## CL:DTC P1094 — TUMBLE GENERATED VALVE SIGNAL 1 CIRCUIT MALFUNCTION (OPEN) —

### • DTC DETECTING CONDITION:

- Immediately at fault recognition
- GENERAL DESCRIPTION <Ref. to GD(STi)-206, DTC P1094 — TUMBLE GENERATED VALVE SIGNAL 1 CIRCUIT MALFUNCTION (OPEN) —, Diagnostic Trouble Code (DTC) Detecting Criteria.>

### CAUTION:

After repair or replacement of faulty parts, conduct Clear Memory Mode <Ref. to EN(STi)-42, OPERATION, Clear Memory Mode.> and Inspection Mode <Ref. to EN(STi)-35, OPERATION, Inspection Mode.>.

### • WIRING DIAGRAM:

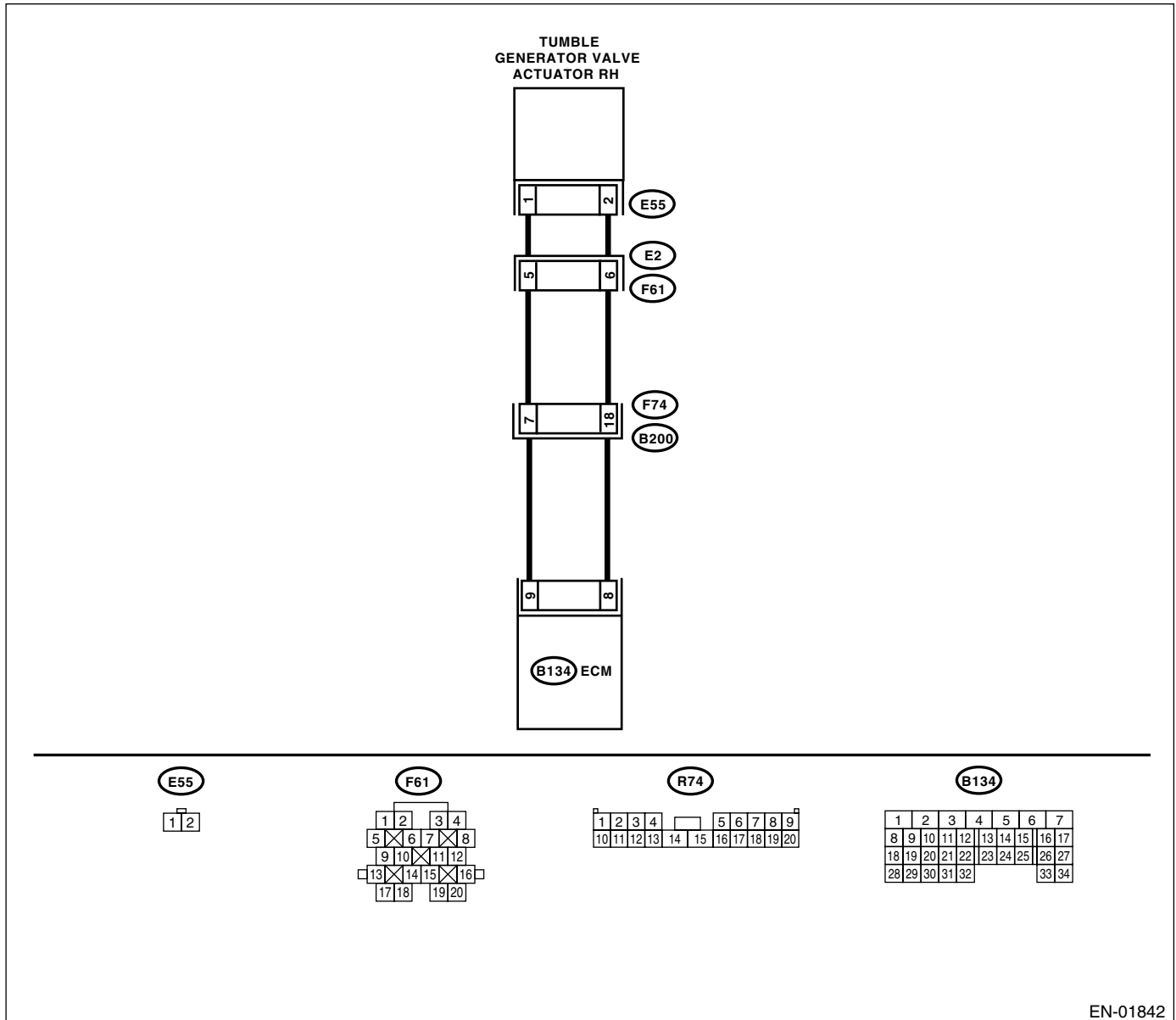

# DIAGNOSTIC PROCEDURE WITH DIAGNOSTIC TROUBLE CODE (DTC)

ENGINE (DIAGNOSTICS)

Step	Check	Yes	No
<p><b>1</b></p> <p><b>CHECK HARNESS BETWEEN ECM AND TUMBLE GENERATOR VALVE ACTUATOR CONNECTOR.</b></p> <p>1) Turn the ignition switch to OFF.                      2) Disconnect the connector from tumble generator valve and ECM connector.                      3) Measure the resistance between tumble generator valve actuator and ECM connector.</p> <p><b>Connector &amp; terminal</b>                      (E55) No. 1 — (B134) No. 9:                      (E55) No. 2 — (B134) No. 8:</p>	<p>Is the resistance less than 1 <math>\Omega</math>?</p>	<p>Go to step 2.</p>	<p>Repair the open circuit between ECM and tumble generator valve connector.</p> <p>NOTE:                      In this case, repair the following:</p> <ul style="list-style-type: none"> <li>• Open circuit in harness between ECM and tumble generator valve actuator connector.</li> <li>• Poor contact in coupling connector.</li> </ul>
<p><b>2</b></p> <p><b>CHECK POOR CONTACT.</b></p> <p>Check poor contact in tumble generator valve actuator connector.</p>	<p>Is there poor contact in tumble generator valve actuator connector?</p>	<p>Repair the poor contact in tumble generator valve actuator connector.</p>	<p>Replace the tumble generator valve assembly.                      &lt;Ref. to FU(STi)-34, Tumble Generator Valve Assembly.&gt;</p>

# DIAGNOSTIC PROCEDURE WITH DIAGNOSTIC TROUBLE CODE (DTC)

ENGINE (DIAGNOSTICS)

## CM:DTC P1095 — TUMBLE GENERATED VALVE SIGNAL 1 CIRCUIT MALFUNCTION (SHORT) —

### • DTC DETECTING CONDITION:

- Immediately at fault recognition
- GENERAL DESCRIPTION <Ref. to GD(STi)-208, DTC P1095 — TUMBLE GENERATED VALVE SIGNAL 1 CIRCUIT MALFUNCTION (SHORT) —, Diagnostic Trouble Code (DTC) Detecting Criteria.>

### CAUTION:

After repair or replacement of faulty parts, conduct Clear Memory Mode <Ref. to EN(STi)-42, OPERATION, Clear Memory Mode.> and Inspection Mode <Ref. to EN(STi)-35, OPERATION, Inspection Mode.>.

### • WIRING DIAGRAM:

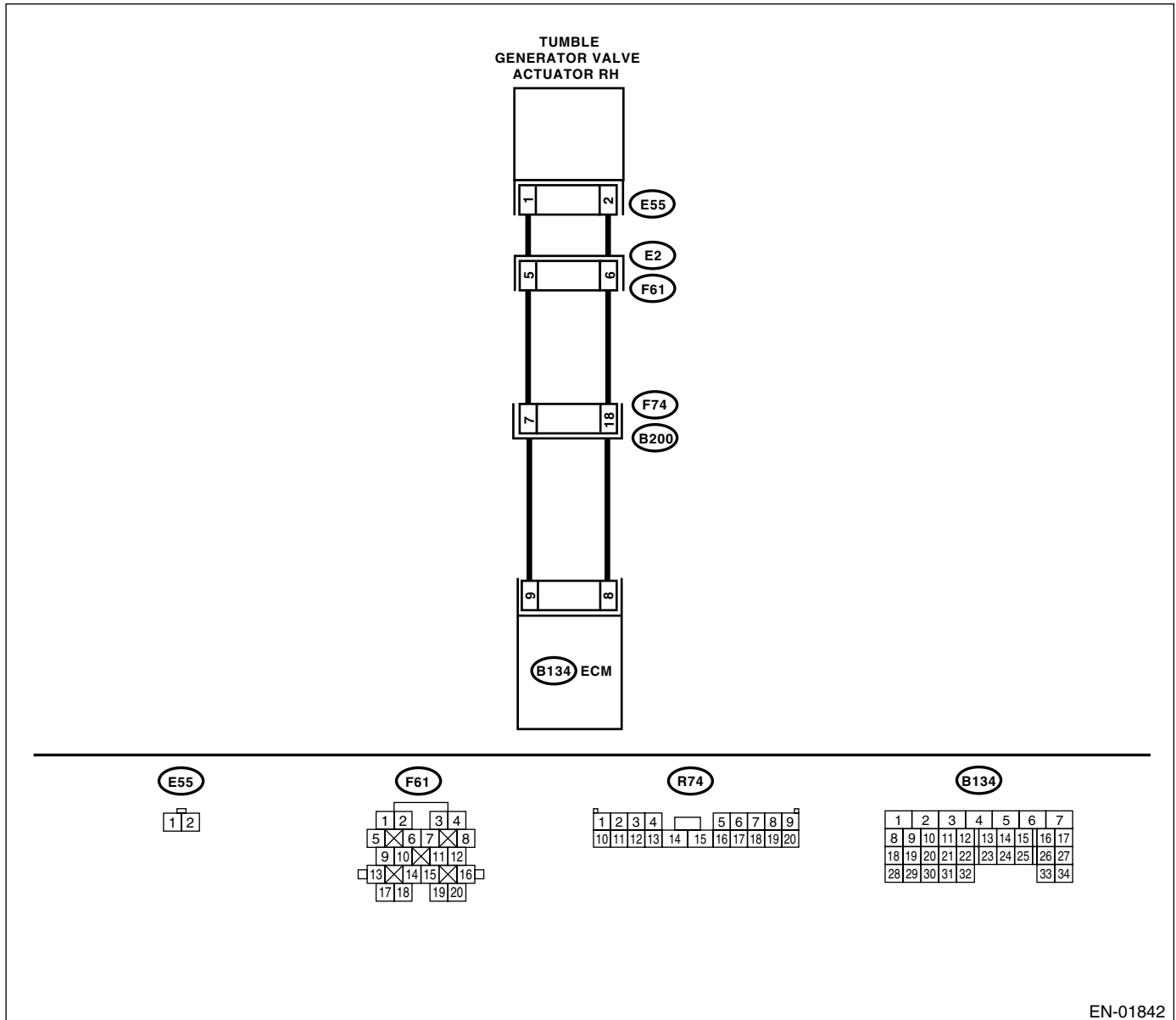

EN-01842

# DIAGNOSTIC PROCEDURE WITH DIAGNOSTIC TROUBLE CODE (DTC)

ENGINE (DIAGNOSTICS)

Step	Check	Yes	No
<p>1</p> <p><b>CHECK HARNESS BETWEEN ECM AND TUMBLE GENERATOR VALVE ACTUATOR CONNECTOR.</b></p> <p>1) Turn the ignition switch to OFF.</p> <p>2) Disconnect the connector from tumble generator valve connector.</p> <p>3) Measure the voltage between tumble generator valve actuator and chassis ground.</p> <p><b>Connector &amp; terminal</b></p> <p><b>(E55) No. 1 (+) — Chassis ground (-):</b></p> <p><b>(E55) No. 2 (+) — Chassis ground (-):</b></p>	<p>Is the voltage less than 5 V?</p>	<p>Replace the tumble generator valve assembly. &lt;Ref. to FU(STi)-34, Tumble Generator Valve Assembly.&gt;</p>	<p>Repair the battery short circuit between ECM and tumble generator valve actuator.</p>

# DIAGNOSTIC PROCEDURE WITH DIAGNOSTIC TROUBLE CODE (DTC)

ENGINE (DIAGNOSTICS)

## CN:DTC P1096 — TUMBLE GENERATED VALVE SIGNAL 2 CIRCUIT MALFUNCTION (OPEN) —

### • DTC DETECTING CONDITION:

- Immediately at fault recognition
- GENERAL DESCRIPTION <Ref. to GD(STi)-210, DTC P1096 — TUMBLE GENERATED VALVE SIGNAL 2 CIRCUIT MALFUNCTION (OPEN) —, Diagnostic Trouble Code (DTC) Detecting Criteria.>

### CAUTION:

After repair or replacement of faulty parts, conduct Clear Memory Mode <Ref. to EN(STi)-42, OPERATION, Clear Memory Mode.> and Inspection Mode <Ref. to EN(STi)-35, OPERATION, Inspection Mode.>.

### • WIRING DIAGRAM:

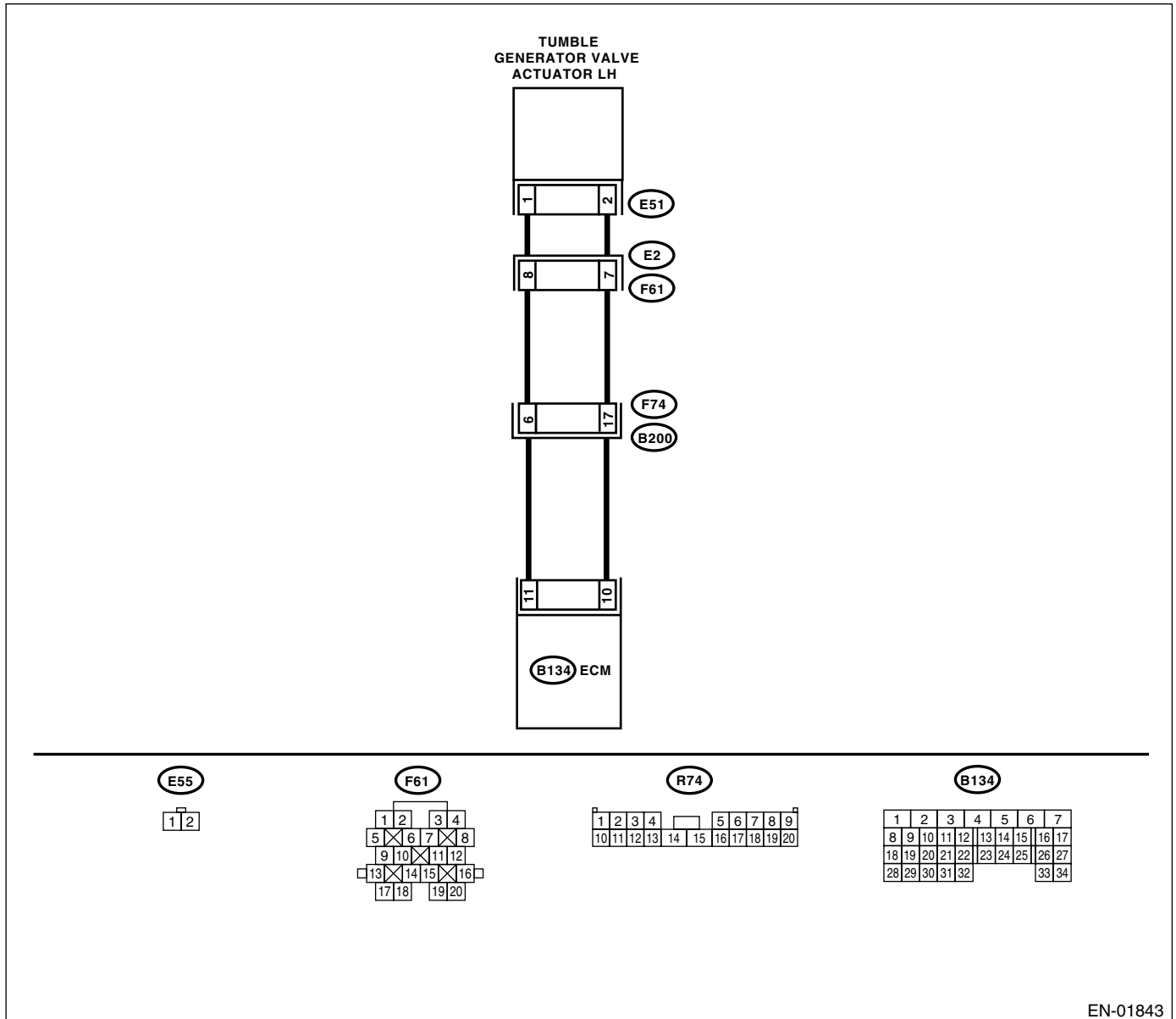

EN-01843

# DIAGNOSTIC PROCEDURE WITH DIAGNOSTIC TROUBLE CODE (DTC)

ENGINE (DIAGNOSTICS)

	Step	Check	Yes	No
1	<p><b>CHECK HARNESS BETWEEN ECM AND TUMBLE GENERATOR VALVE ACTUATOR CONNECTOR.</b></p> <p>1) Turn the ignition switch to OFF.                      2) Disconnect the connector from tumble generator valve and ECM connector.                      3) Measure the resistance between tumble generator valve actuator and ECM connector.</p> <p><b>Connector &amp; terminal</b>                      (E51) No. 1 — (B134) No. 11:                      (E51) No. 2 — (B134) No. 10:</p>	<p>Is the resistance less than 1 <math>\Omega</math>?</p>	<p>Go to step 2.</p>	<p>Repair the open circuit between ECM and tumble generator valve connector.</p> <p>NOTE:                      In this case, repair the following:</p> <ul style="list-style-type: none"> <li>• Open circuit in harness between ECM and tumble generator valve actuator connector.</li> <li>• Poor contact in coupling connector.</li> </ul>
2	<p><b>CHECK POOR CONTACT.</b></p> <p>Check poor contact in tumble generator valve actuator connector.</p>	<p>Is there poor contact in tumble generator valve actuator connector?</p>	<p>Repair the poor contact in tumble generator valve actuator connector.</p>	<p>Replace the tumble generator valve assembly.                      &lt;Ref. to FU(STi)-34, Tumble Generator Valve Assembly.&gt;</p>

# DIAGNOSTIC PROCEDURE WITH DIAGNOSTIC TROUBLE CODE (DTC)

ENGINE (DIAGNOSTICS)

## CO:DTC P1097 — TUMBLE GENERATED VALVE SIGNAL 2 CIRCUIT MALFUNCTION (SHORT) —

### • DTC DETECTING CONDITION:

- Immediately at fault recognition
- GENERAL DESCRIPTION <Ref. to GD(STi)-212, DTC P1097 — TUMBLE GENERATED VALVE SIGNAL 2 CIRCUIT MALFUNCTION (SHORT) —, Diagnostic Trouble Code (DTC) Detecting Criteria.>

### CAUTION:

After repair or replacement of faulty parts, conduct Clear Memory Mode <Ref. to EN(STi)-42, OPERATION, Clear Memory Mode.> and Inspection Mode <Ref. to EN(STi)-35, OPERATION, Inspection Mode.>.

### • WIRING DIAGRAM:

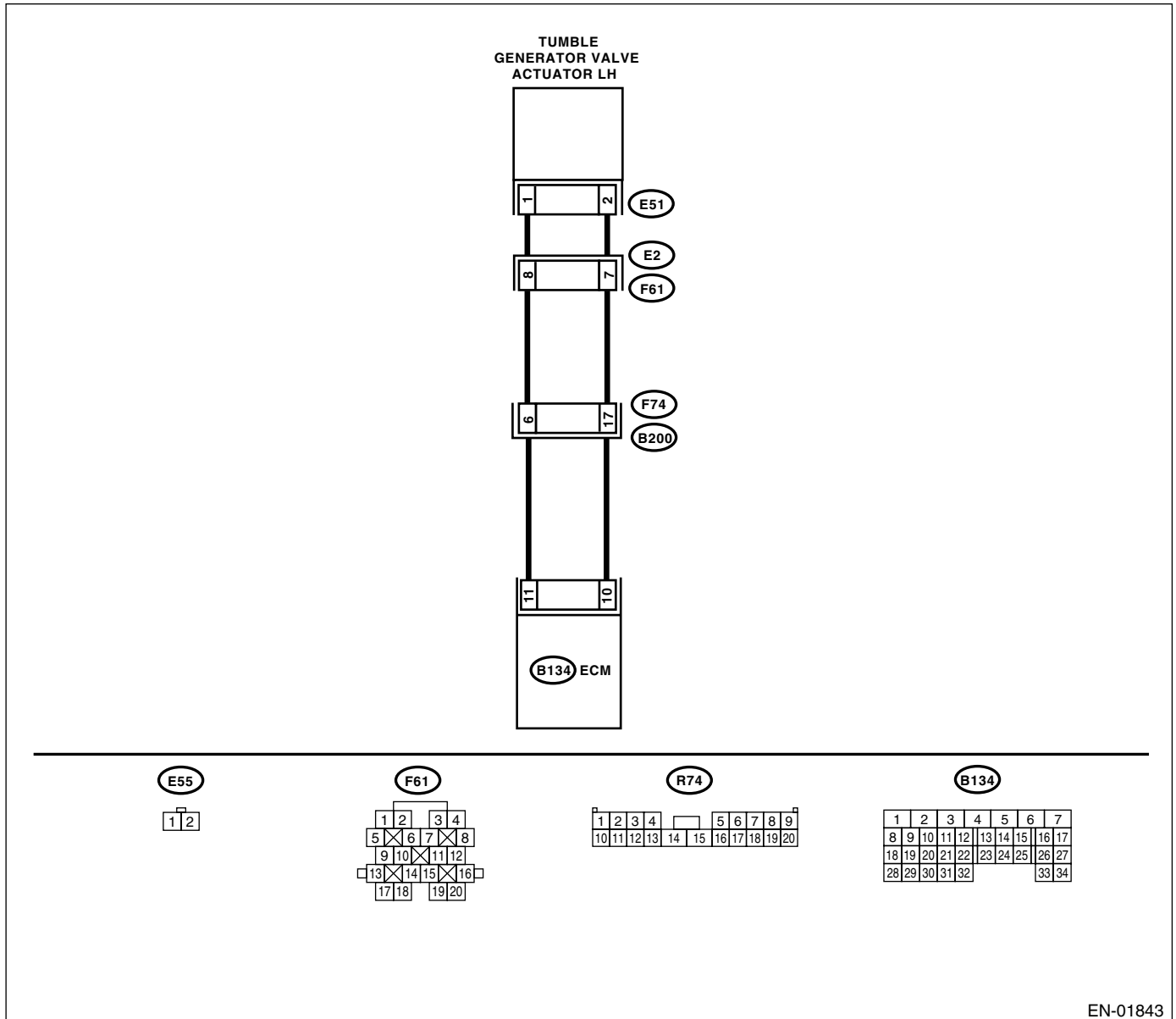

EN-01843



# DIAGNOSTIC PROCEDURE WITH DIAGNOSTIC TROUBLE CODE (DTC)

ENGINE (DIAGNOSTICS)

Step	Check	Yes	No
<p>1</p> <p><b>CHECK HARNESS BETWEEN ECM AND TUMBLE GENERATOR VALVE ACTUATOR CONNECTOR.</b></p> <p>1) Turn the ignition switch to OFF.</p> <p>2) Disconnect the connector from tumble generator valve connector.</p> <p>3) Measure the voltage between tumble generator valve actuator and chassis ground.</p> <p><b>Connector &amp; terminal</b></p> <p><b>(E51) No. 1 (+) — Chassis ground (-):</b></p> <p><b>(E51) No. 2 (+) — Chassis ground (-):</b></p>	<p>Is the voltage less than 5 V?</p>	<p>Replace the tumble generator valve assembly. &lt;Ref. to FU(STi)-34, Tumble Generator Valve Assembly.&gt;</p>	<p>Repair the battery short circuit between ECM and tumble generator valve actuator.</p>

# DIAGNOSTIC PROCEDURE WITH DIAGNOSTIC TROUBLE CODE (DTC)

ENGINE (DIAGNOSTICS)

## CP:DTC P1110 — ATMOSPHERIC PRESSURE SENSOR CIRCUIT MALFUNCTION (LOW INPUT) —

### • DTC DETECTING CONDITION:

- Immediately at fault recognition
- GENERAL DESCRIPTION <Ref. to GD(STi)-214, DTC P1110 — ATMOSPHERIC PRESSURE SENSOR CIRCUIT MALFUNCTION (LOW INPUT) —, Diagnostic Trouble Code (DTC) Detecting Criteria.>

### CAUTION:

After repair or replacement of faulty parts, conduct Clear Memory Mode <Ref. to EN(STi)-42, OPERATION, Clear Memory Mode.> and Inspection Mode <Ref. to EN(STi)-35, OPERATION, Inspection Mode.>.

Step	Check	Yes	No
1 CHECK ANY OTHER DTC ON DISPLAY.	Does the Subaru Select Monitor or OBD-II general scan tool indicate DTC P1110?	Replace the ECM. <Ref. to FU(STi)-41, Engine Control Module (ECM).> NOTE: Atmospheric pressure sensor is built into ECM.	A temporary poor contact.

## CQ:DTC P1111 — ATMOSPHERIC PRESSURE SENSOR CIRCUIT MALFUNCTION (HIGH INPUT) —

### • DTC DETECTING CONDITION:

- Immediately at fault recognition
- GENERAL DESCRIPTION <Ref. to GD(STi)-215, DTC P1111 — ATMOSPHERIC PRESSURE SENSOR CIRCUIT MALFUNCTION (HIGH INPUT) —, Diagnostic Trouble Code (DTC) Detecting Criteria.>

### CAUTION:

After repair or replacement of faulty parts, conduct Clear Memory Mode <Ref. to EN(STi)-42, OPERATION, Clear Memory Mode.> and Inspection Mode <Ref. to EN(STi)-35, OPERATION, Inspection Mode.>.

Step	Check	Yes	No
1 CHECK ANY OTHER DTC ON DISPLAY.	Does the Subaru Select Monitor or OBD-II general scan tool indicate DTC P1111?	Replace the ECM. <Ref. to FU(STi)-41, Engine Control Module (ECM).> NOTE: Atmospheric pressure sensor is built into ECM.	A temporary poor contact.

# DIAGNOSTIC PROCEDURE WITH DIAGNOSTIC TROUBLE CODE (DTC)

ENGINE (DIAGNOSTICS)

## CR: DTC P1152 — O<sub>2</sub> SENSOR CIRCUIT RANGE/PERFORMANCE (LOW) (BANK1 SENSOR1) —

### • DTC DETECTING CONDITION:

- Two consecutive driving cycles with fault
- GENERAL DESCRIPTION <Ref. to GD(STi)-216, DTC P1152 — O<sub>2</sub> SENSOR CIRCUIT RANGE/PERFORMANCE (LOW) (BANK1 SENSOR1) —, Diagnostic Trouble Code (DTC) Detecting Criteria.>

### CAUTION:

After repair or replacement of faulty parts, conduct Clear Memory Mode <Ref. to EN(STi)-42, OPERATION, Clear Memory Mode.> and Inspection Mode <Ref. to EN(STi)-35, OPERATION, Inspection Mode.>.

### • WIRING DIAGRAM:

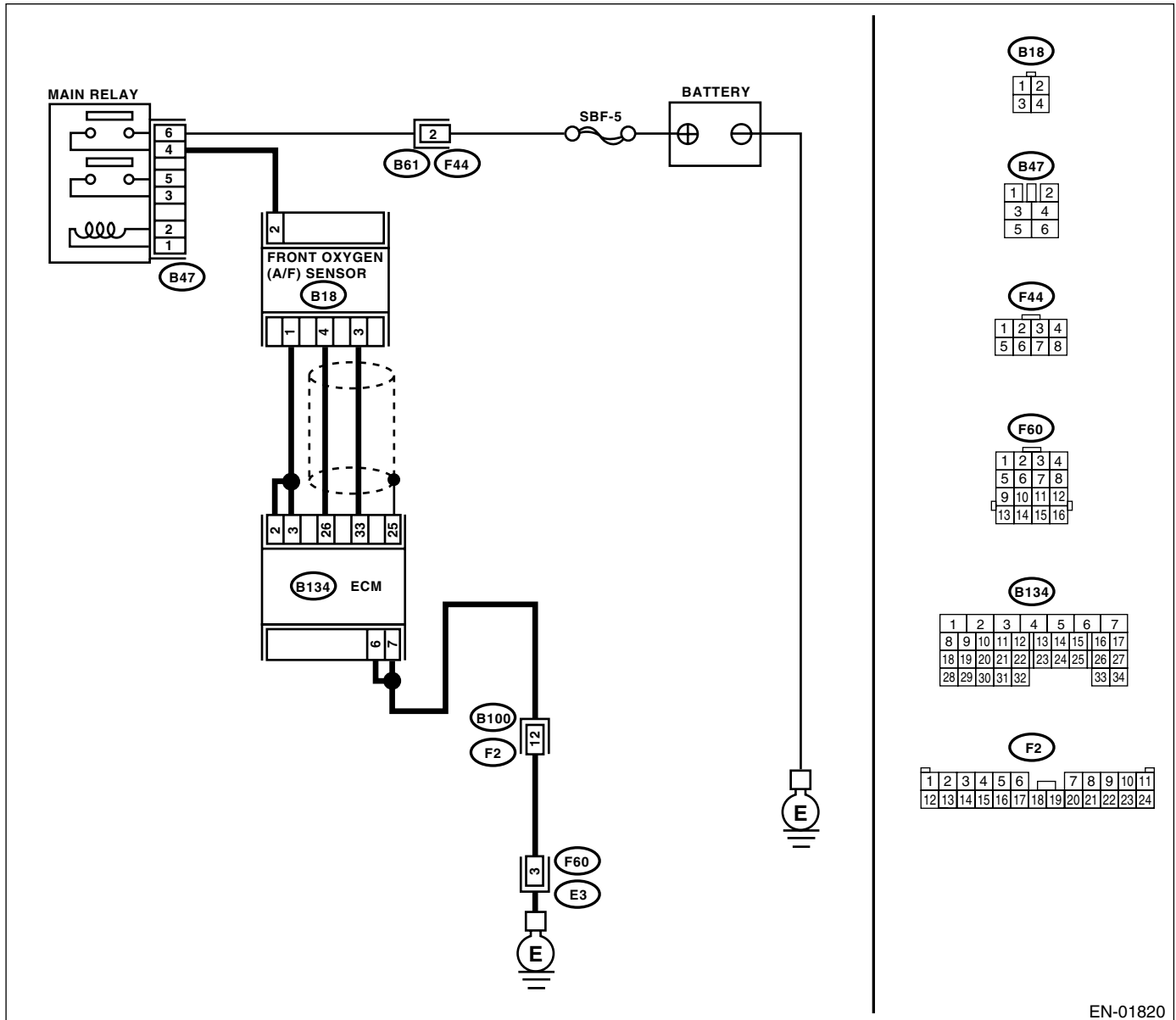

EN-01820

# DIAGNOSTIC PROCEDURE WITH DIAGNOSTIC TROUBLE CODE (DTC)

ENGINE (DIAGNOSTICS)

Step	Check	Yes	No
<p><b>1</b></p> <p><b>CHECK HARNESS BETWEEN ECM AND FRONT OXYGEN (A/F) SENSOR CONNECTOR.</b></p> <p>1) Turn the ignition switch to OFF.                      2) Disconnect the connectors from ECM and front oxygen (A/F) sensor connector.                      3) Measure the resistance of harness between ECM and front oxygen (A/F) sensor connector.</p> <p><b>Connector &amp; terminal</b>  <b>(B134) No. 33 — (B18) No. 3:</b>  <b>(B134) No. 26 — (B18) No. 4:</b></p>	<p>Is the resistance less than 1 <math>\Omega</math>?</p>	<p>Go to step 2.</p>	<p>Repair the harness and connector.</p> <p><b>NOTE:</b>                      In this case, repair the following:</p> <ul style="list-style-type: none"> <li>• Open circuit in harness between ECM and front oxygen (A/F) sensor connector</li> <li>• Poor contact in front oxygen (A/F) sensor connector</li> <li>• Poor contact in ECM connector</li> </ul>
<p><b>2</b></p> <p><b>CHECK POOR CONTACT.</b></p> <p>Check poor contact in front oxygen (A/F) sensor connector.</p>	<p>Is there poor contact in front oxygen (A/F) sensor connector?</p>	<p>Repair the poor contact in front oxygen (A/F) sensor connector.</p>	<p>Replace the front oxygen (A/F) sensor. &lt;Ref. to FU(STi)-37, Front Oxygen (A/F) Sensor.&gt;</p>

# DIAGNOSTIC PROCEDURE WITH DIAGNOSTIC TROUBLE CODE (DTC)

ENGINE (DIAGNOSTICS)

## CS: DTC P1153 — O<sub>2</sub> SENSOR CIRCUIT RANGE/PERFORMANCE (HIGH) (BANK1 SENSOR1) —

### • DTC DETECTING CONDITION:

- Two consecutive driving cycles with fault
- GENERAL DESCRIPTION <Ref. to GD(STi)-219, DTC P1153 — O<sub>2</sub> SENSOR CIRCUIT RANGE/PERFORMANCE (HIGH) (BANK1 SENSOR1) —, Diagnostic Trouble Code (DTC) Detecting Criteria.>

### CAUTION:

After repair or replacement of faulty parts, conduct Clear Memory Mode <Ref. to EN(STi)-42, OPERATION, Clear Memory Mode.> and Inspection Mode <Ref. to EN(STi)-35, OPERATION, Inspection Mode.>.

### • WIRING DIAGRAM:

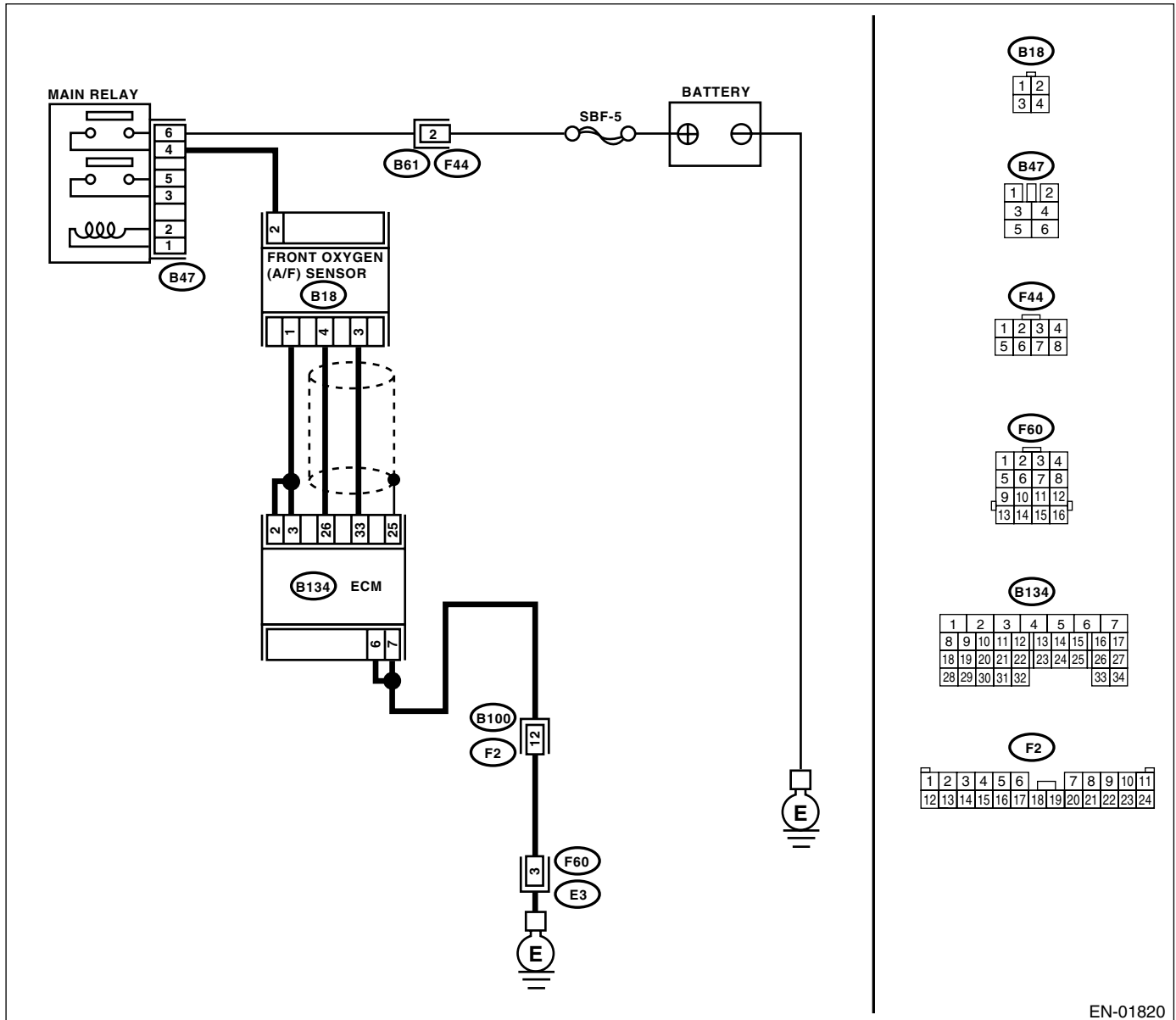

EN-01820

# DIAGNOSTIC PROCEDURE WITH DIAGNOSTIC TROUBLE CODE (DTC)

ENGINE (DIAGNOSTICS)

Step	Check	Yes	No
<b>1 CHECK HARNESS BETWEEN ECM AND FRONT OXYGEN (A/F) SENSOR CONNECTOR.</b> 1) Turn the ignition switch to OFF. 2) Disconnect the connector from ECM. 3) Measure the resistance of harness between ECM connector and chassis ground. <i>Connector &amp; terminal</i> <i>(B134) No. 26 — Chassis ground:</i>	Is the resistance more than 1 MΩ?	Repair the ground short circuit in harness between ECM and front oxygen (A/F) sensor connector.	Go to step 2.
<b>2 CHECK HARNESS BETWEEN ECM AND FRONT OXYGEN (A/F) SENSOR CONNECTOR.</b> Measure the resistance of harness between ECM connector and chassis ground. <i>Connector &amp; terminal</i> <i>(B134) No. 33 — Chassis ground:</i>	Is the resistance more than 1 MΩ?	Repair the ground short circuit in harness between ECM and front oxygen (A/F) sensor connector.	Go to step 3.
<b>3 CHECK OUTPUT SIGNAL FOR ECM.</b> 1) Connect the connector to ECM. 2) Turn the ignition switch to ON. 3) Measure the voltage between ECM connector and chassis ground. <i>Connector &amp; terminal</i> <i>(B134) No. 26 (+) — Chassis ground (-):</i>	Is the voltage more than 4.5 V?	Go to step 4.	Go to step 5.
<b>4 CHECK OUTPUT SIGNAL FOR ECM.</b> Measure the voltage between ECM connector and chassis ground. <i>Connector &amp; terminal</i> <i>(B134) No. 26 (+) — Chassis ground (-):</i>	Is the voltage more than 10 V?	Repair the battery short circuit in harness between ECM and front oxygen (A/F) sensor connector. After repair, replace the ECM. <Ref. to FU(STi)-41, Engine Control Module (ECM).>	Repair the poor contact in ECM connector.
<b>5 CHECK OUTPUT SIGNAL FOR ECM.</b> Measure the voltage between ECM connector and chassis ground. <i>Connector &amp; terminal</i> <i>(B134) No. 33 (+) — Chassis ground (-):</i>	Is the voltage more than 4.95 V?	Go to step 6.	Replace the front oxygen (A/F) sensor. <Ref. to FU(STi)-37, Front Oxygen (A/F) Sensor.>
<b>6 CHECK OUTPUT SIGNAL FOR ECM.</b> Measure the voltage between ECM connector and chassis ground. <i>Connector &amp; terminal</i> <i>(B134) No. 33 (+) — Chassis ground (-):</i>	Is the voltage more than 10 V?	Repair the battery short circuit in harness between ECM and front oxygen (A/F) sensor connector. After repair, replace the ECM. <Ref. to FU(STi)-41, Engine Control Module (ECM).>	Repair the poor contact in ECM connector.

## CT:DTC P1160 — RETURN SPRING FAILURE —

NOTE:

For the diagnostic procedure, refer to DTC P2101. <Ref. to EN(STi)-325, DTC P2101 — THROTTLE ACTUATOR CONTROL MOTOR CIRCUIT RANGE/PERFORMANCE —, Diagnostic Procedure with Diagnostic Trouble Code (DTC).>

# DIAGNOSTIC PROCEDURE WITH DIAGNOSTIC TROUBLE CODE (DTC)

ENGINE (DIAGNOSTICS)

## CU:DTC P1400 — FUEL TANK PRESSURE CONTROL SOLENOID VALVE CIRCUIT LOW —

### • DTC DETECTING CONDITION:

- Two consecutive driving cycles with fault
- GENERAL DESCRIPTION <Ref. to GD(STi)-224, DTC P1400 — FUEL TANK PRESSURE CONTROL SOLENOID VALVE CIRCUIT LOW —, Diagnostic Trouble Code (DTC) Detecting Criteria.>

### CAUTION:

After repair or replacement of faulty parts, conduct Clear Memory Mode <Ref. to EN(STi)-42, OPERATION, Clear Memory Mode.> and Inspection Mode <Ref. to EN(STi)-35, OPERATION, Inspection Mode.>.

### • WIRING DIAGRAM:

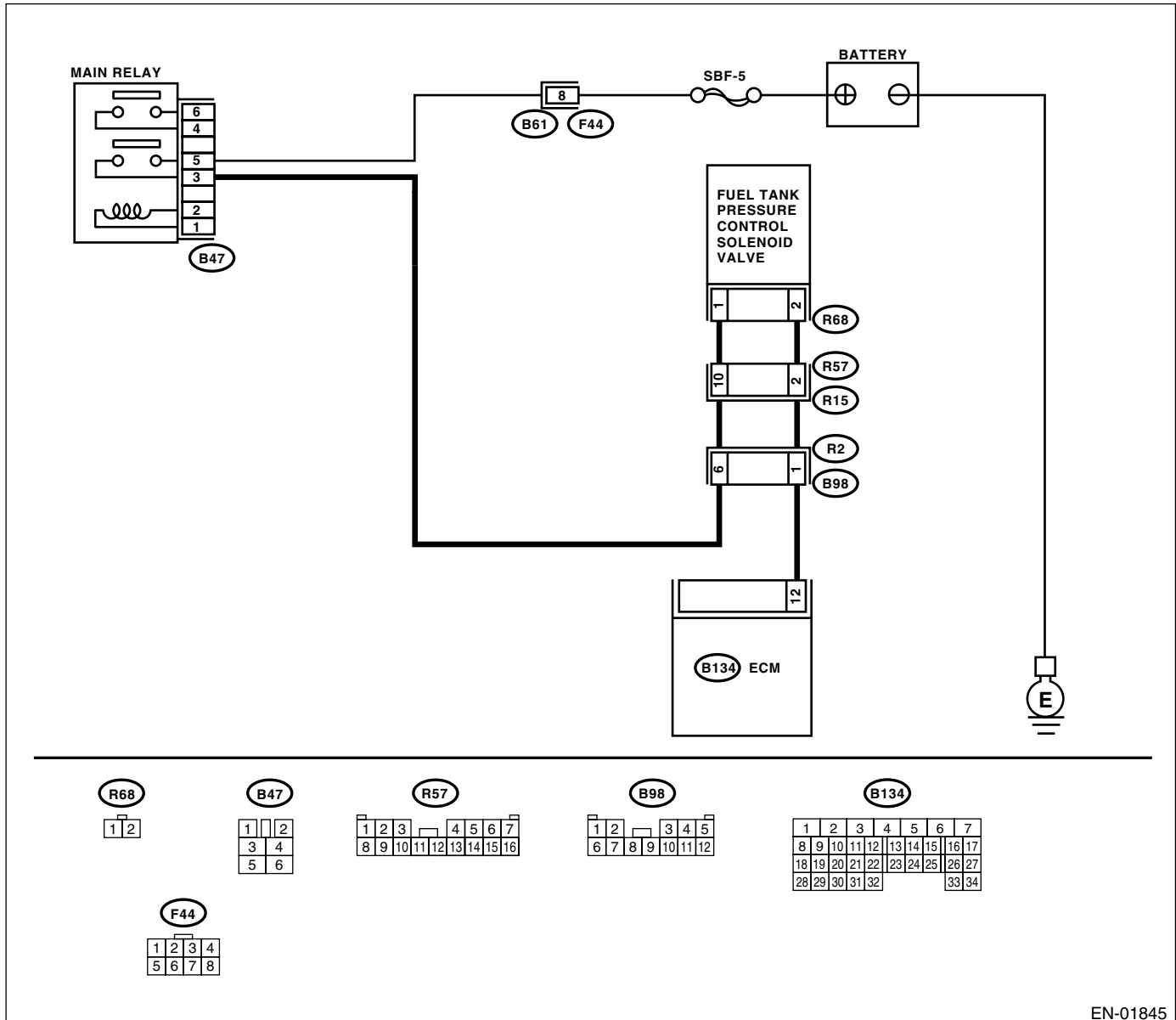

EN-01845

# DIAGNOSTIC PROCEDURE WITH DIAGNOSTIC TROUBLE CODE (DTC)

ENGINE (DIAGNOSTICS)

Step	Check	Yes	No
<b>1 CHECK OUTPUT SIGNAL FROM ECM.</b> 1) Turn ignition switch to ON. 2) Measure the voltage between ECM and chassis ground. <b>Connector &amp; terminal</b> <b>(B134) No. 12 (+) — Chassis ground (-):</b>	Is the voltage more than 10 V?	Go to step 2.	Go to step 3.
<b>2 CHECK FOR POOR CONTACT.</b> Check for poor contact in ECM connector.	Is there poor contact in ECM connector?	Repair poor contact in ECM connector.	Contact with SOA Service Center. NOTE: Inspection by DTM is required, because probable cause is deterioration of multiple parts.
<b>3 CHECK HARNESS BETWEEN FUEL TANK PRESSURE CONTROL SOLENOID VALVE AND ECM CONNECTOR.</b> 1) Turn ignition switch to OFF. 2) Disconnect the connectors from fuel tank pressure control solenoid valve and ECM. 3) Measure the resistance of harness between fuel tank pressure control solenoid valve connector and chassis ground. <b>Connector &amp; terminal</b> <b>(R68) No. 2 — Chassis ground:</b>	Is the resistance more than 1 M $\Omega$ ?	Go to step 4.	Repair short circuit to ground in harness between ECM and fuel tank pressure control solenoid valve connector.
<b>4 CHECK HARNESS BETWEEN FUEL TANK PRESSURE CONTROL SOLENOID VALVE AND ECM CONNECTOR.</b> Measure the resistance of harness between ECM and fuel tank pressure control solenoid valve connector. <b>Connector &amp; terminal</b> <b>(B134) No. 12 — (R68) No. 2:</b>	Is the resistance less than 1 $\Omega$ ?	Go to step 5.	Repair harness and connector. NOTE: In this case, repair the following: <ul style="list-style-type: none"> <li>• Open circuit in harness between ECM and fuel tank pressure control solenoid valve connector</li> <li>• Poor contact in coupling connector</li> </ul>
<b>5 CHECK FUEL TANK PRESSURE CONTROL SOLENOID VALVE.</b> Measure the resistance between fuel tank pressure control solenoid valve terminals. <b>Terminals</b> <b>No. 1 — No. 2:</b>	Is the resistance 10 — 100 $\Omega$ ?	Go to step 6.	Replace the fuel tank pressure control solenoid valve. <Ref. to EC(STi)-6, Purge Control Solenoid Valve.>



# DIAGNOSTIC PROCEDURE WITH DIAGNOSTIC TROUBLE CODE (DTC)

ENGINE (DIAGNOSTICS)

Step	Check	Yes	No
<p><b>6</b></p> <p><b>CHECK POWER SUPPLY TO FUEL TANK PRESSURE CONTROL SOLENOID VALVE.</b>                      1) Turn ignition switch to ON.                      2) Measure the voltage between fuel tank pressure control solenoid valve and chassis ground.</p> <p><b>Connector &amp; terminal</b>  <b>(R68) No. 1 (+) — Chassis ground (-):</b></p>	<p>Is the voltage more than 10 V?</p>	<p>Go to step 7.</p>	<p>Repair harness and connector.</p> <p><b>NOTE:</b>                      In this case, repair the following:</p> <ul style="list-style-type: none"> <li>• Open circuit in harness between main relay and fuel tank pressure control solenoid valve connector</li> <li>• Poor contact in coupling connector</li> <li>• Poor contact in main relay connector</li> </ul>
<p><b>7</b></p> <p><b>CHECK FOR POOR CONTACT.</b>                      Check for poor contact in fuel tank pressure control solenoid valve connector.</p>	<p>Is there poor contact in fuel tank pressure control solenoid valve connector?</p>	<p>Repair poor contact in fuel tank pressure control solenoid valve connector.</p>	<p>Contact with SOA Service Center.</p> <p><b>NOTE:</b>                      Inspection by DTM is required, because probable cause is deterioration of multiple parts.</p>

# DIAGNOSTIC PROCEDURE WITH DIAGNOSTIC TROUBLE CODE (DTC)

ENGINE (DIAGNOSTICS)

## CV:DTC P1420 — FUEL TANK PRESSURE CONTROL SOL. VALVE CIRCUIT HIGH —

### • DTC DETECTING CONDITION:

- Two consecutive driving cycles with fault
- GENERAL DESCRIPTION <Ref. to GD(STi)-226, DTC P1420 — FUEL TANK PRESSURE CONTROL SOL. VALVE CIRCUIT HIGH —, Diagnostic Trouble Code (DTC) Detecting Criteria.>

### CAUTION:

After repair or replacement of faulty parts, conduct Clear Memory Mode <Ref. to EN(STi)-42, OPERATION, Clear Memory Mode.> and Inspection Mode <Ref. to EN(STi)-35, OPERATION, Inspection Mode.>.

### • WIRING DIAGRAM:

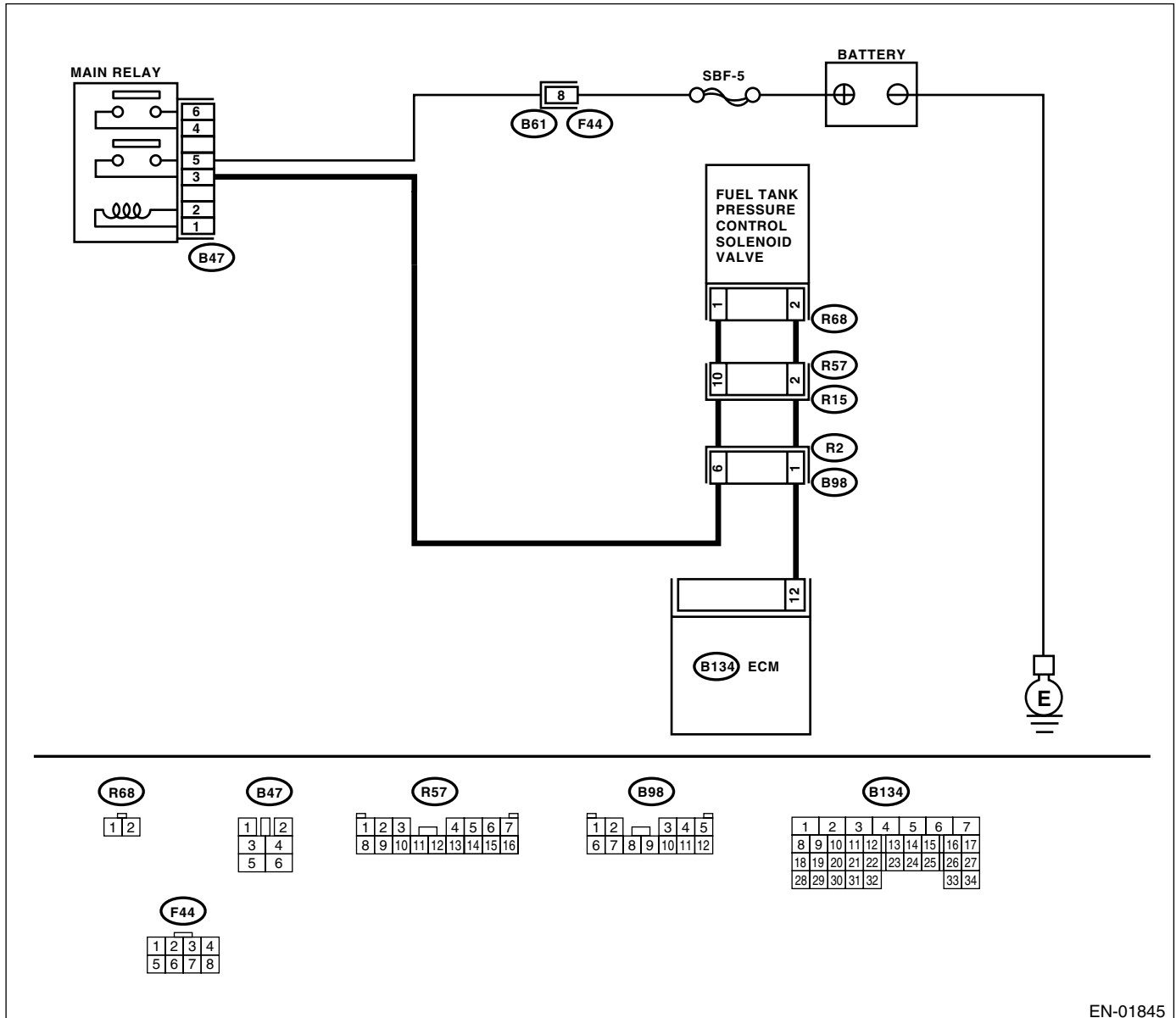

EN-01845

# DIAGNOSTIC PROCEDURE WITH DIAGNOSTIC TROUBLE CODE (DTC)

ENGINE (DIAGNOSTICS)

Step	Check	Yes	No
<p><b>1 CHECK INPUT SIGNAL FOR ECM.</b>                      1) Turn ignition switch to OFF.                      2) Connect the test mode connector at the lower portion of instrument panel (on the driver's side).                      3) Turn ignition switch to ON.                      4) While operating the fuel tank pressure control solenoid valve, measure voltage between ECM and chassis ground.</p> <p>NOTE:                      Fuel tank pressure control solenoid valve operation can be executed using Subaru Select Monitor. For the procedure, refer to "Compulsory Valve Operation Check Mode". &lt;Ref. to EN(STi)-43, Compulsory Valve Operation Check Mode.&gt;</p> <p><b>Connector &amp; terminal</b>  <b>(B134) No. 12 (+) — Chassis ground (-):</b></p>	<p>Does the voltage value change 0 — 10 V?</p>	<p>Go to step 2.</p>	<p>The malfunction indicator light may light up, however, the circuit is returned to the normal status at the moment. In this case, repair poor contact in ECM connector.</p>
<p><b>2 CHECK INPUT SIGNAL FOR ECM.</b>                      1) Turn ignition switch to ON.                      2) Measure the voltage between ECM and chassis ground.</p> <p><b>Connector &amp; terminal</b>  <b>(B134) No. 12 (+) — Chassis ground (-):</b></p>	<p>Is the voltage more than 10 V?</p>	<p>Go to step 4.</p>	<p>Go to step 3.</p>
<p><b>3 CHECK FOR POOR CONTACT.</b>                      Check for poor contact in ECM connector.</p>	<p>Is there poor contact in ECM connector?</p>	<p>Repair poor contact in ECM connector.</p>	<p>Replace the ECM. &lt;Ref. to FU(STi)-41, Engine Control Module (ECM).&gt;</p>
<p><b>4 CHECK HARNESS BETWEEN FUEL TANK PRESSURE CONTROL SOLENOID VALVE AND ECM CONNECTOR.</b>                      1) Turn ignition switch to OFF.                      2) Disconnect the connector from fuel tank pressure control solenoid valve.                      3) Turn ignition switch to ON.                      4) Measure the voltage between ECM and chassis ground.</p> <p><b>Connector &amp; terminal</b>  <b>(B134) No. 12 (+) — Chassis ground (-):</b></p>	<p>Is the voltage more than 10 V?</p>	<p>Repair short circuit to battery in harness between ECM and fuel tank pressure control solenoid valve connector. After repair, replace the ECM. &lt;Ref. to FU(STi)-41, Engine Control Module (ECM).&gt;</p>	<p>Go to step 5.</p>
<p><b>5 CHECK FUEL TANK PRESSURE CONTROL SOLENOID VALVE.</b>                      1) Turn ignition switch to OFF.                      2) Measure the resistance between fuel tank pressure control solenoid valve terminals.</p> <p><b>Terminals</b>  <b>No. 1 — No. 2:</b></p>	<p>Is the resistance less than 1 <math>\Omega</math>?</p>	<p>Replace the fuel tank pressure control solenoid valve &lt;Ref. to EC(STi)-12, Pressure Control Solenoid Valve.&gt; and the ECM &lt;Ref. to FU(STi)-41, Engine Control Module (ECM).&gt;.</p>	<p>Go to step 6.</p>
<p><b>6 CHECK FOR POOR CONTACT.</b>                      Check for poor contact in ECM connector.</p>	<p>Is there poor contact in ECM connector?</p>	<p>Repair poor contact in ECM connector.</p>	<p>Replace the ECM. &lt;Ref. to FU(STi)-41, Engine Control Module (ECM).&gt;</p>

# DIAGNOSTIC PROCEDURE WITH DIAGNOSTIC TROUBLE CODE (DTC)

ENGINE (DIAGNOSTICS)

## CW:DTC P1443 — VENT CONTROL SOLENOID VALVE FUNCTION PROBLEM

### • DTC DETECTING CONDITION:

- Immediately at fault recognition
- GENERAL DESCRIPTION <Ref. to GD(STi)-228, DTC P1443 — VENT CONTROL SOLENOID VALVE FUNCTION PROBLEM —, Diagnostic Trouble Code (DTC) Detecting Criteria.>

### • TROUBLE SYMPTOM:

- Improper fuel supply

### CAUTION:

After repair or replacement of faulty parts, conduct Clear Memory Mode <Ref. to EN(STi)-42, OPERATION, Clear Memory Mode.> and Inspection Mode <Ref. to EN(STi)-35, OPERATION, Inspection Mode.>.

### • WIRING DIAGRAM:

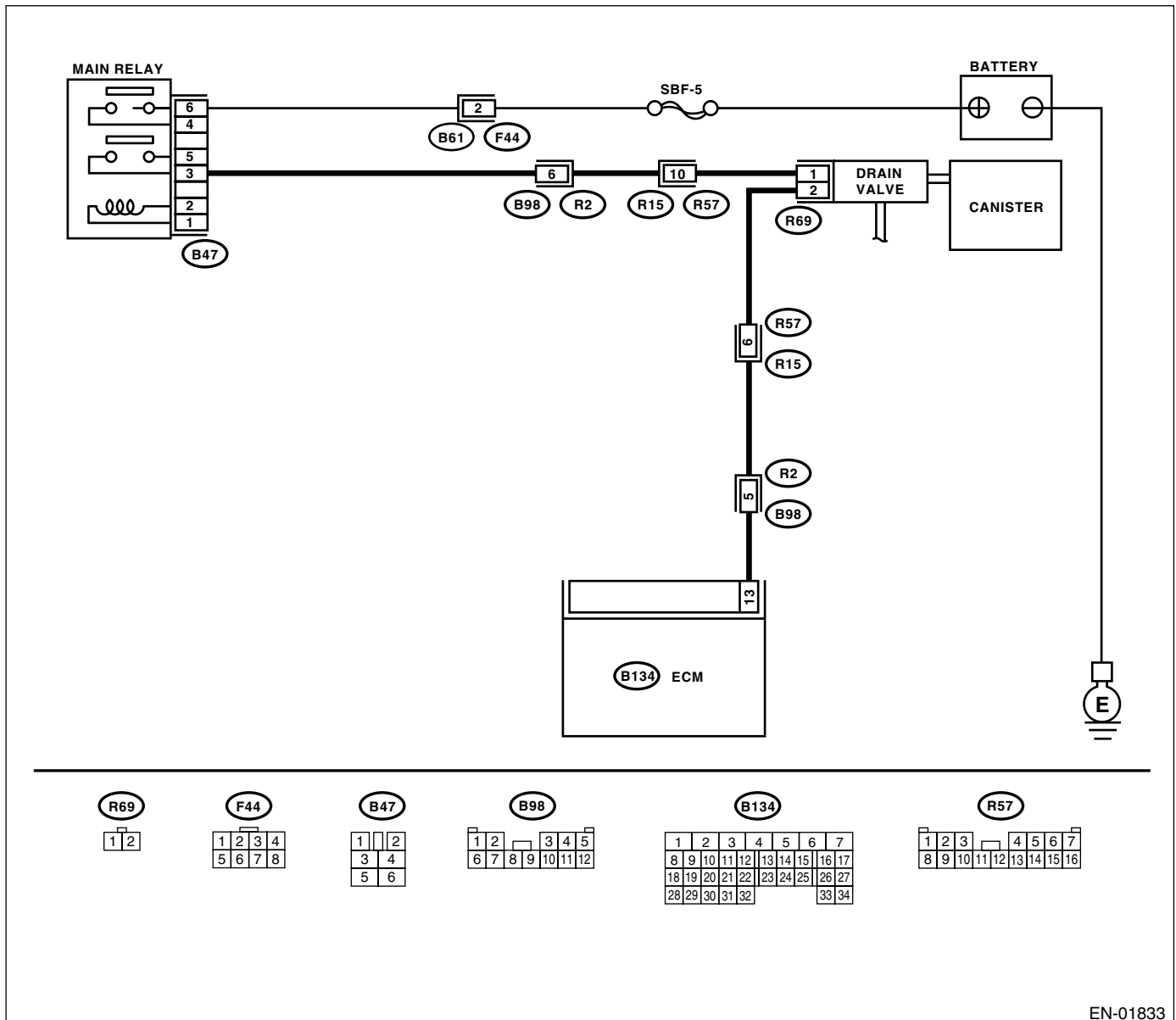

EN-01833

# DIAGNOSTIC PROCEDURE WITH DIAGNOSTIC TROUBLE CODE (DTC)

ENGINE (DIAGNOSTICS)

	Step	Check	Yes	No
1	<b>CHECK FOR OTHER DTC ON DISPLAY.</b>	Is any other DTC displayed?	Inspect the relevant DTC using "List of Diagnostic Trouble Code (DTC)". <Ref. to EN(STi)-66, List of Diagnostic Trouble Code (DTC).>	Go to step 2.
2	<b>CHECK VENT LINE HOSES.</b> Check the following items. <ul style="list-style-type: none"><li>•Clogging of vent hoses between canister and drain valve</li><li>•Clogging of vent hose between drain valve and air filter</li><li>•Clogging of drain filter</li></ul>	Is there a fault in vent line?	Repair or replace faulty parts.	Go to step 3.
3	<b>CHECK DRAIN VALVE OPERATION.</b> 1)Turn ignition switch to OFF. 2)Connect the test mode connector at the lower portion of instrument panel (on the driver's side). 3)Turn ignition switch to ON. 4)Operate the drain valve.  NOTE: Drain valve operation can also be executed using Subaru Select Monitor. For the procedure, refer to "Compulsory Valve Operation Check Mode". <Ref. to EN(STi)-43, Compulsory Valve Operation Check Mode.>	Does the drain valve operate?	Contact with SOA Service Center.  NOTE: Inspection by DTM is required, because probable cause is deterioration of multiple parts.	Replace the drain valve. <Ref. to EC(STi)-18, Drain Valve.>

# DIAGNOSTIC PROCEDURE WITH DIAGNOSTIC TROUBLE CODE (DTC)

ENGINE (DIAGNOSTICS)

## CX:DTC P1446 — FUEL TANK SENSOR CONTROL VALVE CIRCUIT LOW —

### • DTC DETECTING CONDITION:

- Two consecutive driving cycles with fault
- GENERAL DESCRIPTION <Ref. to GD(STi)-229, DTC P1446 — FUEL TANK SENSOR CONTROL VALVE CIRCUIT LOW —, Diagnostic Trouble Code (DTC) Detecting Criteria.>

### CAUTION:

After repair or replacement of faulty parts, conduct Clear Memory Mode <Ref. to EN(STi)-42, OPERATION, Clear Memory Mode.> and Inspection Mode <Ref. to EN(STi)-35, OPERATION, Inspection Mode.>.

### • WIRING DIAGRAM:

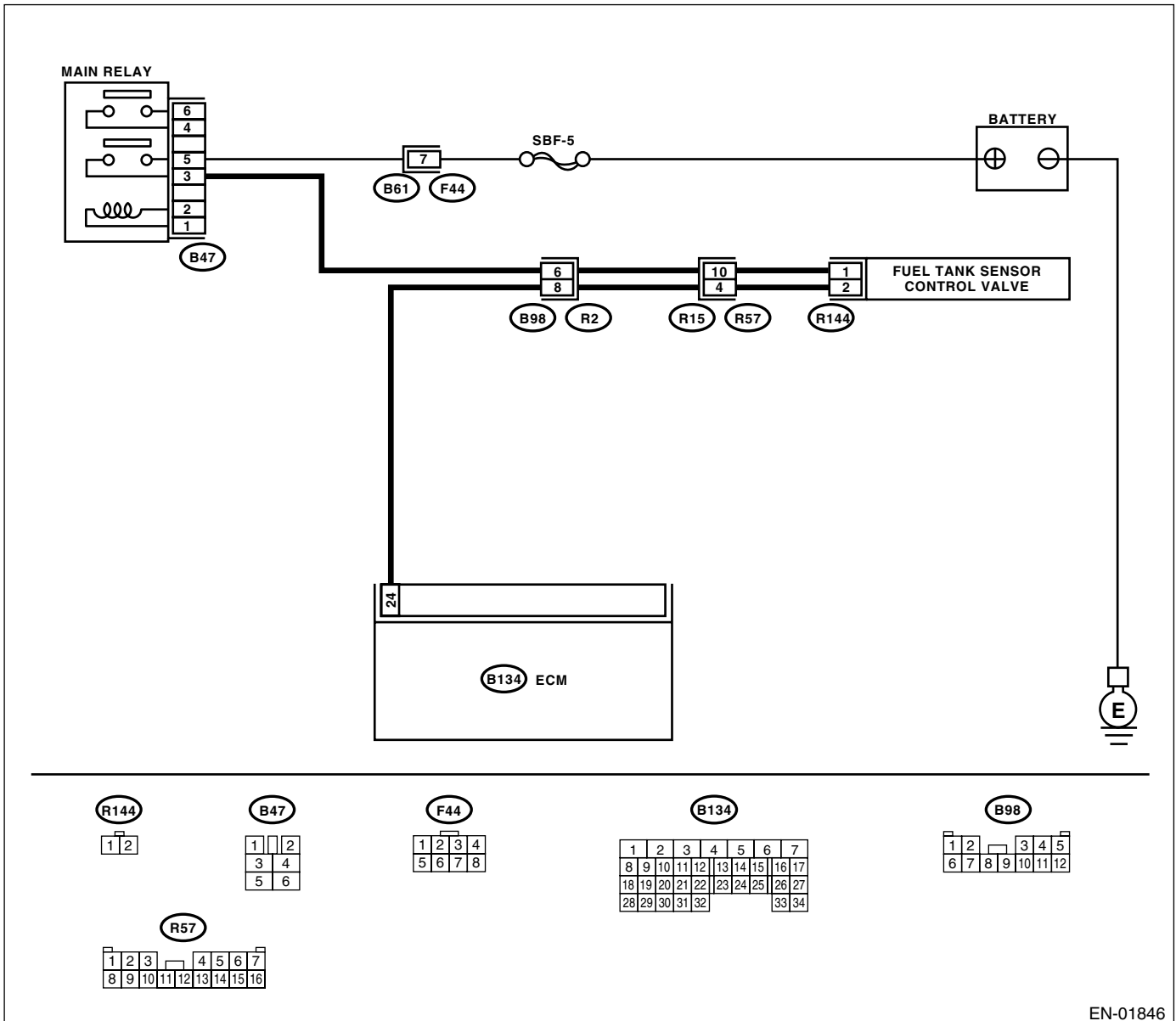

EN-01846

# DIAGNOSTIC PROCEDURE WITH DIAGNOSTIC TROUBLE CODE (DTC)

ENGINE (DIAGNOSTICS)

Step	Check	Yes	No
<b>1 CHECK OUTPUT SIGNAL FROM ECM.</b> 1) Turn ignition switch to ON. 2) Measure the voltage between ECM and chassis ground. <b>Connector &amp; terminal</b> <b>(B134) No. 24 (+) — Chassis ground (-):</b>	Is the voltage more than 10 V?	Go to step 2.	Go to step 3.
<b>2 CHECK FOR POOR CONTACT.</b> Check for poor contact in ECM connector.	Is there poor contact in ECM connector?	Repair poor contact in ECM connector.	The malfunction indicator light may light up, however, the circuit is returned to the normal status at the moment. (However, the possibility of poor contact still remains.) NOTE: In this case, repair the following: <ul style="list-style-type: none"> <li>• Poor contact in fuel tank sensor control valve connector</li> <li>• Poor contact in ECM connector</li> <li>• Poor contact in coupling connector</li> </ul>
<b>3 CHECK HARNESS BETWEEN FUEL TANK SENSOR CONTROL VALVE AND ECM CONNECTOR.</b> 1) Turn ignition switch to OFF. 2) Disconnect the connectors from fuel tank sensor control valve and ECM. 3) Measure the resistance of harness between fuel tank sensor control valve connector and chassis ground. <b>Connector &amp; terminal</b> <b>(R144) No. 2 — Chassis ground:</b>	Is the resistance more than 1 M $\Omega$ ?	Go to step 4.	Repair short circuit to ground in harness between ECM and fuel tank sensor control valve connector.
<b>4 CHECK HARNESS BETWEEN FUEL TANK SENSOR CONTROL VALVE AND ECM CONNECTOR.</b> Measure the resistance of harness between ECM and fuel tank sensor control valve connector. <b>Connector &amp; terminal</b> <b>(B134) No. 24 — (R144) No. 2:</b>	Is the resistance less than 1 $\Omega$ ?	Go to step 5.	Repair harness and connector. NOTE: In this case, repair the following: <ul style="list-style-type: none"> <li>• Open circuit in harness between ECM and fuel tank sensor control valve connector</li> <li>• Poor contact in coupling connector</li> </ul>
<b>5 CHECK FUEL TANK SENSOR CONTROL VALVE.</b> Measure the resistance between fuel tank sensor control valve terminals. <b>Terminals</b> <b>No. 1 — No. 2:</b>	Is the resistance 10 — 100 $\Omega$ ?	Go to step 6.	Replace the fuel tank sensor control valve. <Ref. to EC(STi)-18, Drain Valve.>

# DIAGNOSTIC PROCEDURE WITH DIAGNOSTIC TROUBLE CODE (DTC)

ENGINE (DIAGNOSTICS)

Step	Check	Yes	No
<p><b>6</b></p> <p><b>CHECK POWER SUPPLY TO FUEL TANK SENSOR CONTROL VALVE.</b></p> <p>1) Turn ignition switch to ON. 2) Measure the voltage between fuel tank sensor control valve and chassis ground.</p> <p><b>Connector &amp; terminal</b> <b>(R144) No. 1 (+) — Chassis ground (-):</b></p>	<p>Is the voltage more than 10 V?</p>	<p>Go to step 7.</p>	<p>Repair harness and connector.</p> <p><b>NOTE:</b> In this case, repair the following:</p> <ul style="list-style-type: none"> <li>• Open circuit in harness between main relay and fuel tank sensor control valve</li> <li>• Poor contact in coupling connector</li> <li>• Poor contact in main relay connector</li> </ul>
<p><b>7</b></p> <p><b>CHECK FOR POOR CONTACT.</b></p> <p>Check for poor contact in fuel tank sensor control valve connector.</p>	<p>Is there poor contact in fuel tank sensor control valve connector?</p>	<p>Repair poor contact in fuel tank sensor control valve connector.</p>	<p>Contact with SOA Service Center.</p> <p><b>NOTE:</b> Inspection by DTM is required, because probable cause is deterioration of multiple parts.</p>



# DIAGNOSTIC PROCEDURE WITH DIAGNOSTIC TROUBLE CODE (DTC)

ENGINE (DIAGNOSTICS)

## CY:DTC P1447 — FUEL TANK SENSOR CONTROL VALVE CIRCUIT HIGH —

### • DTC DETECTING CONDITION:

- Two consecutive driving cycles with fault
- GENERAL DESCRIPTION <Ref. to GD(STi)-231, DTC P1447 — FUEL TANK SENSOR CONTROL VALVE CIRCUIT HIGH —, Diagnostic Trouble Code (DTC) Detecting Criteria.>

### CAUTION:

After repair or replacement of faulty parts, conduct Clear Memory Mode <Ref. to EN(STi)-42, OPERATION, Clear Memory Mode.> and Inspection Mode <Ref. to EN(STi)-35, OPERATION, Inspection Mode.>.

### • WIRING DIAGRAM:

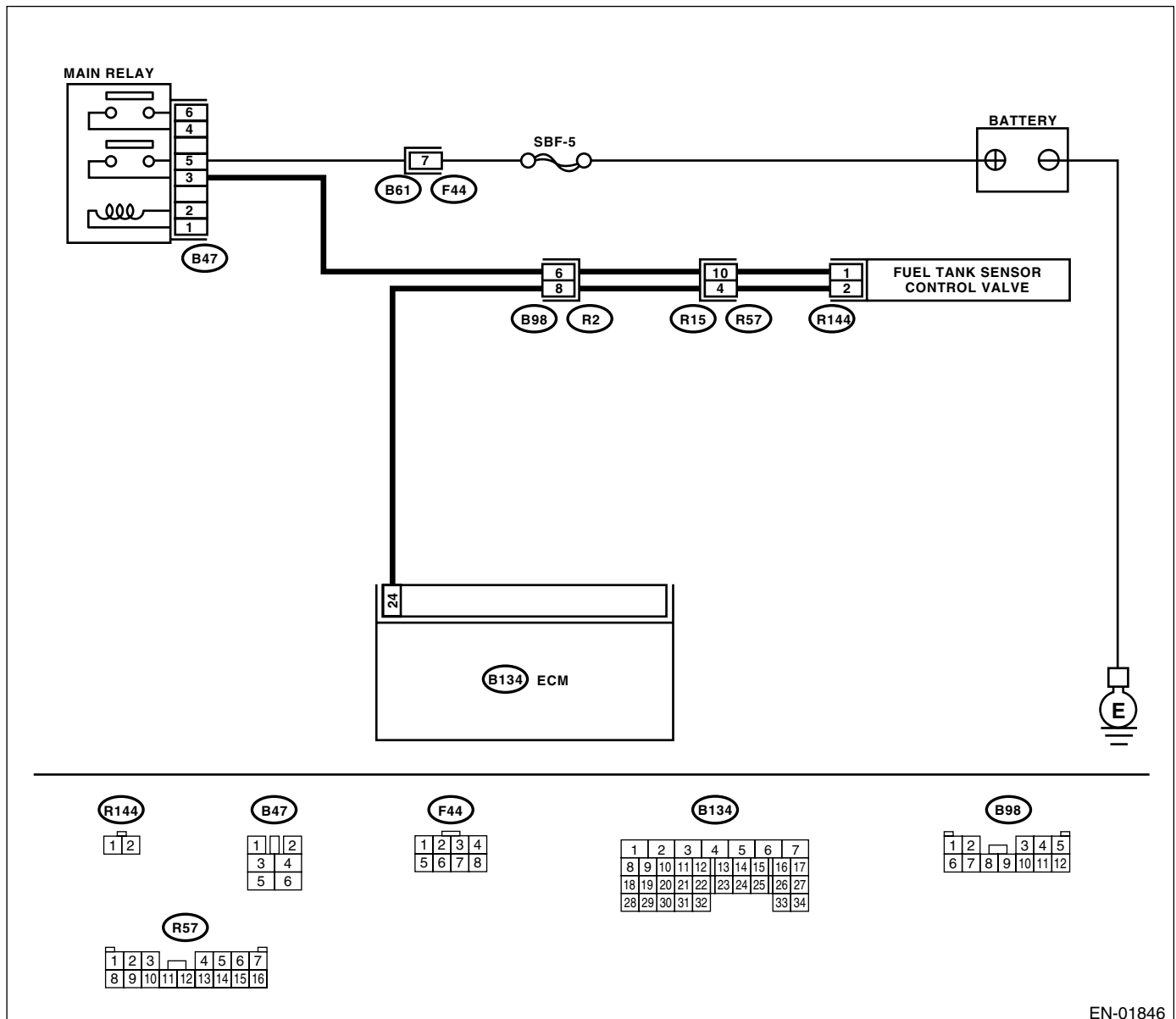

EN-01846

# DIAGNOSTIC PROCEDURE WITH DIAGNOSTIC TROUBLE CODE (DTC)

## ENGINE (DIAGNOSTICS)

Step	Check	Yes	No
<b>1</b> <b>CHECK OUTPUT SIGNAL FROM ECM.</b> 1) Turn ignition switch to ON. 2) Measure the voltage between ECM and chassis ground. <b>Connector &amp; terminal</b> <b>(B134) No. 24 (+) — Chassis ground (-):</b>	Is the voltage more than 10 V?	Go to step 3.	Go to step 2.
<b>2</b> <b>CHECK FOR POOR CONTACT.</b> Check for poor contact in ECM connector.	Is there poor contact in ECM connector?	Repair poor contact in ECM connector.	Replace the ECM. <Ref. to FU(STi)-41, Engine Control Module (ECM).>
<b>3</b> <b>CHECK HARNESS BETWEEN FUEL TANK SENSOR CONTROL VALVE AND ECM CONNECTOR.</b> 1) Turn ignition switch to OFF. 2) Disconnect the connector from fuel tank sensor control valve. 3) Turn ignition switch to ON. 4) Measure the voltage between ECM and chassis ground. <b>Connector &amp; terminal</b> <b>(B134) No. 24 (+) — Chassis ground (-):</b>	Is the voltage more than 10 V?	Repair short circuit to battery in harness between ECM and fuel tank sensor control valve connector. After repair, replace the ECM. <Ref. to FU(STi)-41, Engine Control Module (ECM).>	Go to step 4.
<b>4</b> <b>CHECK FUEL TANK SENSOR CONTROL VALVE.</b> 1) Turn ignition switch to OFF. 2) Measure the resistance between fuel tank sensor control valve terminals. <b>Terminals</b> <b>No. 1 — No. 2:</b>	Is the resistance less than 1 $\Omega$ ?	Replace the fuel tank sensor control valve <Ref. to EC(STi)-11, Fuel Tank Sensor Control Valve.> and the ECM <Ref. to FU(STi)-41, Engine Control Module (ECM).>.	Go to step 5.
<b>5</b> <b>CHECK FOR POOR CONTACT.</b> Check for poor contact in ECM connector.	Is there poor contact in ECM connector?	Repair poor contact in ECM connector.	Replace the ECM. <Ref. to FU(STi)-41, Engine Control Module (ECM).>

# DIAGNOSTIC PROCEDURE WITH DIAGNOSTIC TROUBLE CODE (DTC)

ENGINE (DIAGNOSTICS)

## CZ:DTC P1448 — FUEL TANK SENSOR CONTROL VALVE RANGE/PERFORMANCE —

### • DTC DETECTING CONDITION:

- Two consecutive driving cycles with fault
- GENERAL DESCRIPTION <Ref. to GD(STi)-233, DTC P1448 — FUEL TANK SENSOR CONTROL VALVE RANGE PERFORMANCE —, Diagnostic Trouble Code (DTC) Detecting Criteria.>

### CAUTION:

After repair or replacement of faulty parts, conduct Clear Memory Mode <Ref. to EN(STi)-42, OPERATION, Clear Memory Mode.> and Inspection Mode <Ref. to EN(STi)-35, OPERATION, Inspection Mode.>.

### • WIRING DIAGRAM:

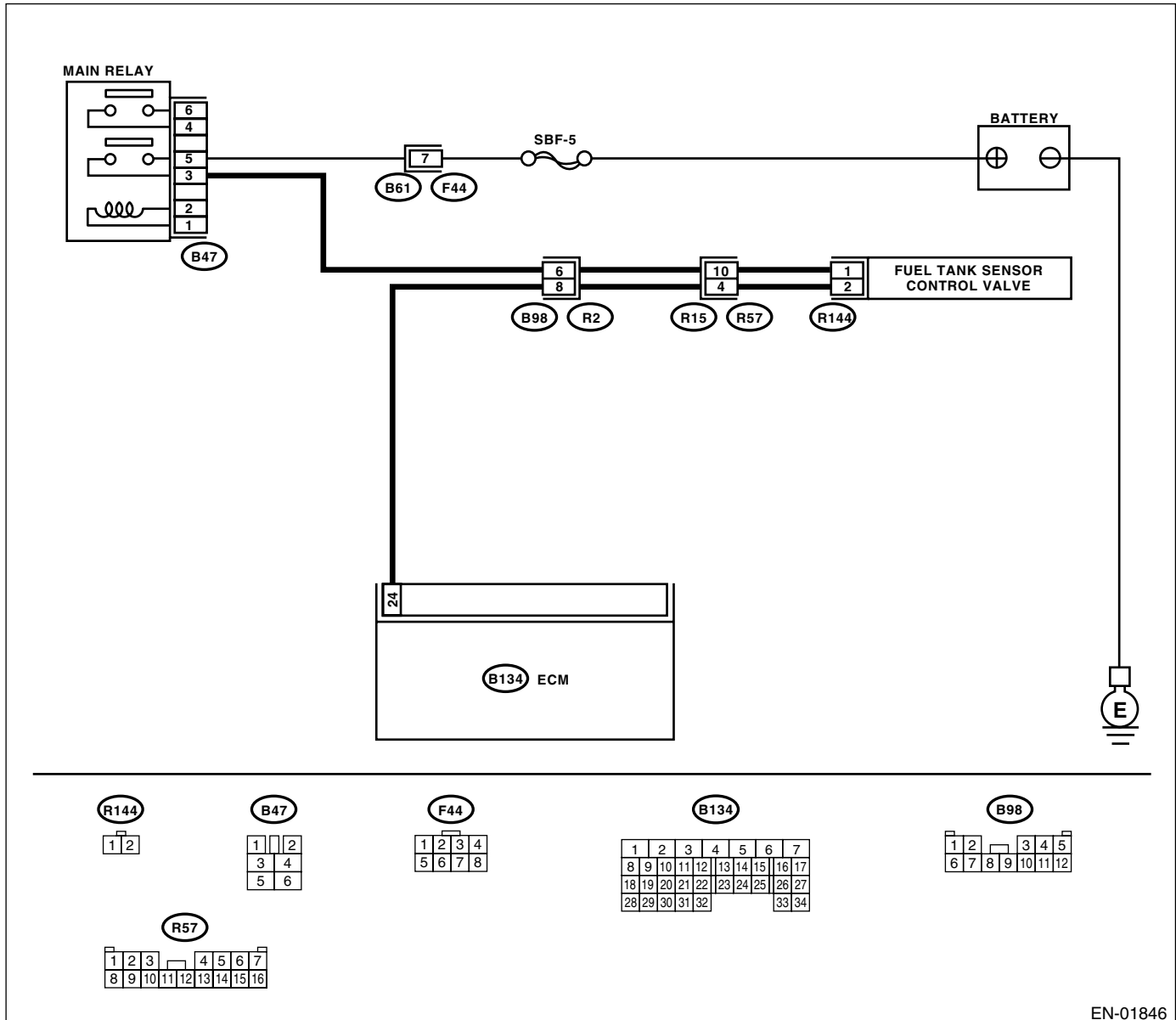

EN-01846

# DIAGNOSTIC PROCEDURE WITH DIAGNOSTIC TROUBLE CODE (DTC)

## ENGINE (DIAGNOSTICS)

	Step	Check	Yes	No
1	<b>CHECK FOR OTHER DTC ON DISPLAY.</b>	Is any other DTC displayed?	Inspect the relevant DTC using the "List of Diagnostic Trouble Codes (DTC)". <Ref. to EN(STi)-66, List of Diagnostic Trouble Code (DTC).>	Go to step 2.
2	<b>CHECK FUEL FILLER CAP.</b> 1) Turn ignition switch to OFF. 2) Open the fuel flap.	Is the fuel filler cap tightened securely?	Go to step 3.	Tighten fuel filler cap securely.
3	<b>CHECK EVAPORATIVE EMISSION LINE.</b> NOTE: Check the following items. • Disconnection, leakage and clogging of hoses between fuel tank pressure sensor and fuel tank. • Disconnection, leakage and clogging of hoses and pipes between fuel filler pipe and fuel tank.	Is there any trouble in evaporative emission line?	Repair the hoses and pipes.	Replace the fuel tank pressure sensor.

# DIAGNOSTIC PROCEDURE WITH DIAGNOSTIC TROUBLE CODE (DTC)

ENGINE (DIAGNOSTICS)

## DA:DTC P1491 — POSITIVE CRANKCASE VENTILATION (BLOW-BY) FUNCTION PROBLEM —

### • DTC DETECTING CONDITION:

- Two consecutive driving cycles with fault
- GENERAL DESCRIPTION <Ref. to GD(STi)-236, DTC P1491 — POSITIVE CRANKCASE VENTILATION (BLOW-BY) FUNCTION PROBLEM —, Diagnostic Trouble Code (DTC) Detecting Criteria.>

### • TROUBLE SYMPTOM:

- Erroneous idling

### CAUTION:

After repair or replacement of faulty parts, conduct Clear Memory Mode <Ref. to EN(STi)-42, OPERATION, Clear Memory Mode.> and Inspection Mode <Ref. to EN(STi)-35, OPERATION, Inspection Mode.>.

### • WIRING DIAGRAM:

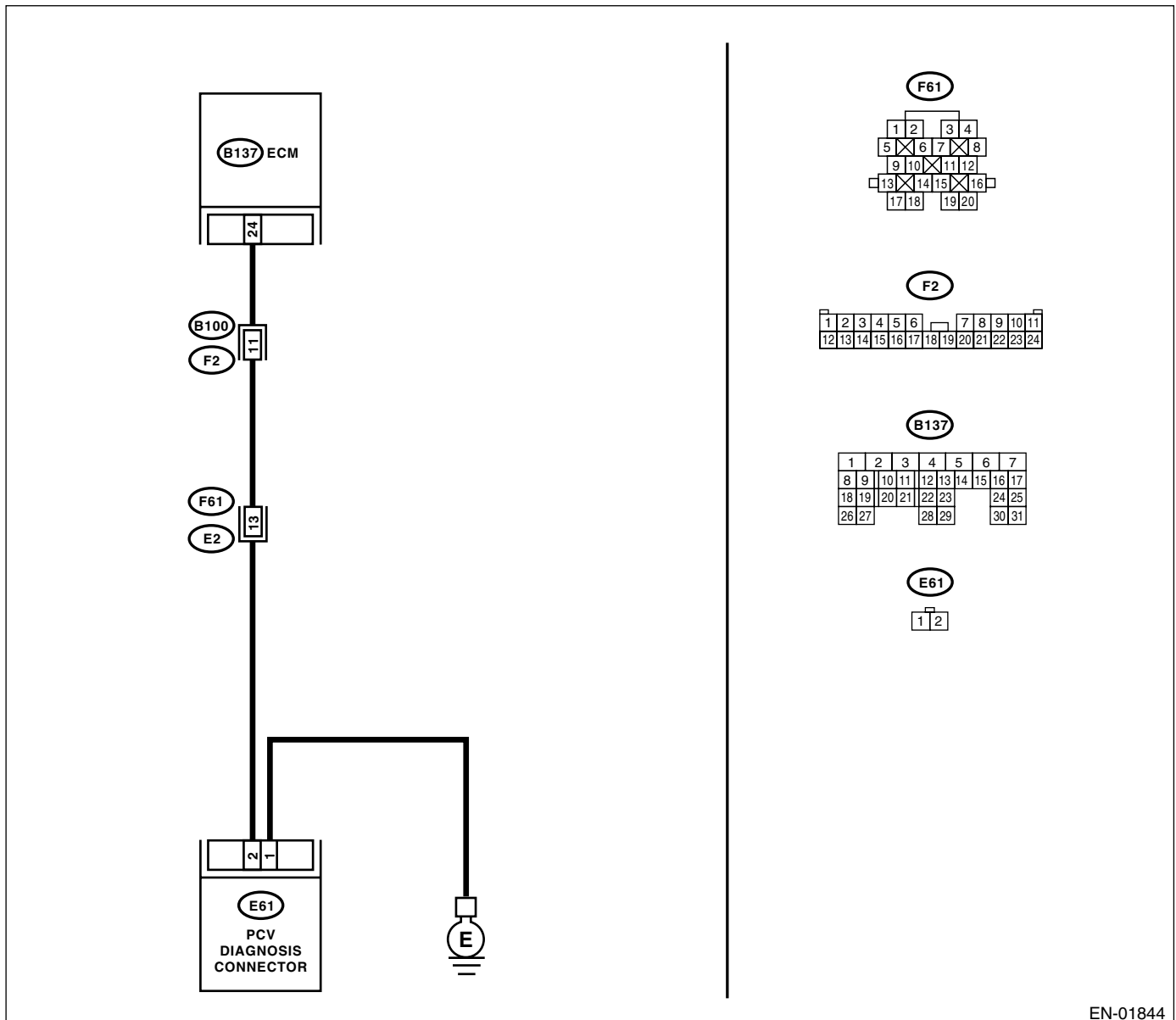

EN-01844

# DIAGNOSTIC PROCEDURE WITH DIAGNOSTIC TROUBLE CODE (DTC)

## ENGINE (DIAGNOSTICS)

	Step	Check	Yes	No
1	<b>CHECK BLOW-BY HOSE.</b> Check the blow-by hose.	Is there disconnection or crack in blow-by hose?	Replace or repair blow-by hose.	Go to step 2.
2	<b>INSPECT HARNESS BETWEEN PCV DIAGNOSIS CONNECTOR AND ECM CONNECTOR.</b> 1) Turn the ignition switch to OFF. 2) Disconnect the connector from PCV diagnosis connector and ECM. 3) Measure the resistance of harness between PCV diagnosis connector and ECM connector. <b>Connector &amp; terminal</b> <b>(B137) No. 24 — (E61) No. 2:</b>	Is the resistance less than 1 $\Omega$ ?	Go to step 3.	Repair open circuit in harness between PCV diagnosis connector and ECM.
3	<b>INSPECT HARNESS BETWEEN PCV DIAGNOSIS CONNECTOR AND ECM CONNECTOR.</b> Measure the resistance of harness between PCV diagnosis connector and chassis ground. <b>Connector &amp; terminal</b> <b>(B137) No. 24 — Chassis ground:</b>	Is the resistance more than 1 M $\Omega$ ?	Go to step 4.	Repair short circuit to chassis ground in harness between PCV diagnosis connector and ECM.
4	<b>INSPECT PCV DIAGNOSIS CONNECTOR GROUND CIRCUIT.</b> Measure the resistance between PCV diagnosis connector and engine ground. <b>Connector &amp; terminal</b> <b>(B61) No. 1 — Engine ground:</b>	Is the resistance less than 5 $\Omega$ ?	Go to step 5.	Repair PCV diagnosis connector ground circuit.
5	<b>INSPECT PCV DIAGNOSIS CONNECTOR.</b> Measure the resistance between PCV diagnosis connector and terminal. <b>Terminals</b> <b>No. 1 — No. 2:</b>	Is the resistance less than 1 $\Omega$ ?	Repair poor contact in ECM and PCV diagnosis connector.	Replace PCV diagnosis connector.

## DIAGNOSTIC PROCEDURE WITH DIAGNOSTIC TROUBLE CODE (DTC)

ENGINE (DIAGNOSTICS)

### DB:DTC P1518 — STARTER SWITCH CIRCUIT LOW INPUT —

• **DTC DETECTING CONDITION:**

- Two consecutive driving cycles with fault
- GENERAL DESCRIPTION <Ref. to GD(STi)-238, DTC P1518 — STARTER SWITCH CIRCUIT LOW INPUT —, Diagnostic Trouble Code (DTC) Detecting Criteria.>

• **TROUBLE SYMPTOM:**

- Failure of engine to start

**CAUTION:**

After repair or replacement of faulty parts, conduct Clear Memory Mode <Ref. to EN(STi)-42, OPERATION, Clear Memory Mode.> and Inspection Mode <Ref. to EN(STi)-35, OPERATION, Inspection Mode.>.

# DIAGNOSTIC PROCEDURE WITH DIAGNOSTIC TROUBLE CODE (DTC)

## ENGINE (DIAGNOSTICS)

### • WIRING DIAGRAM:

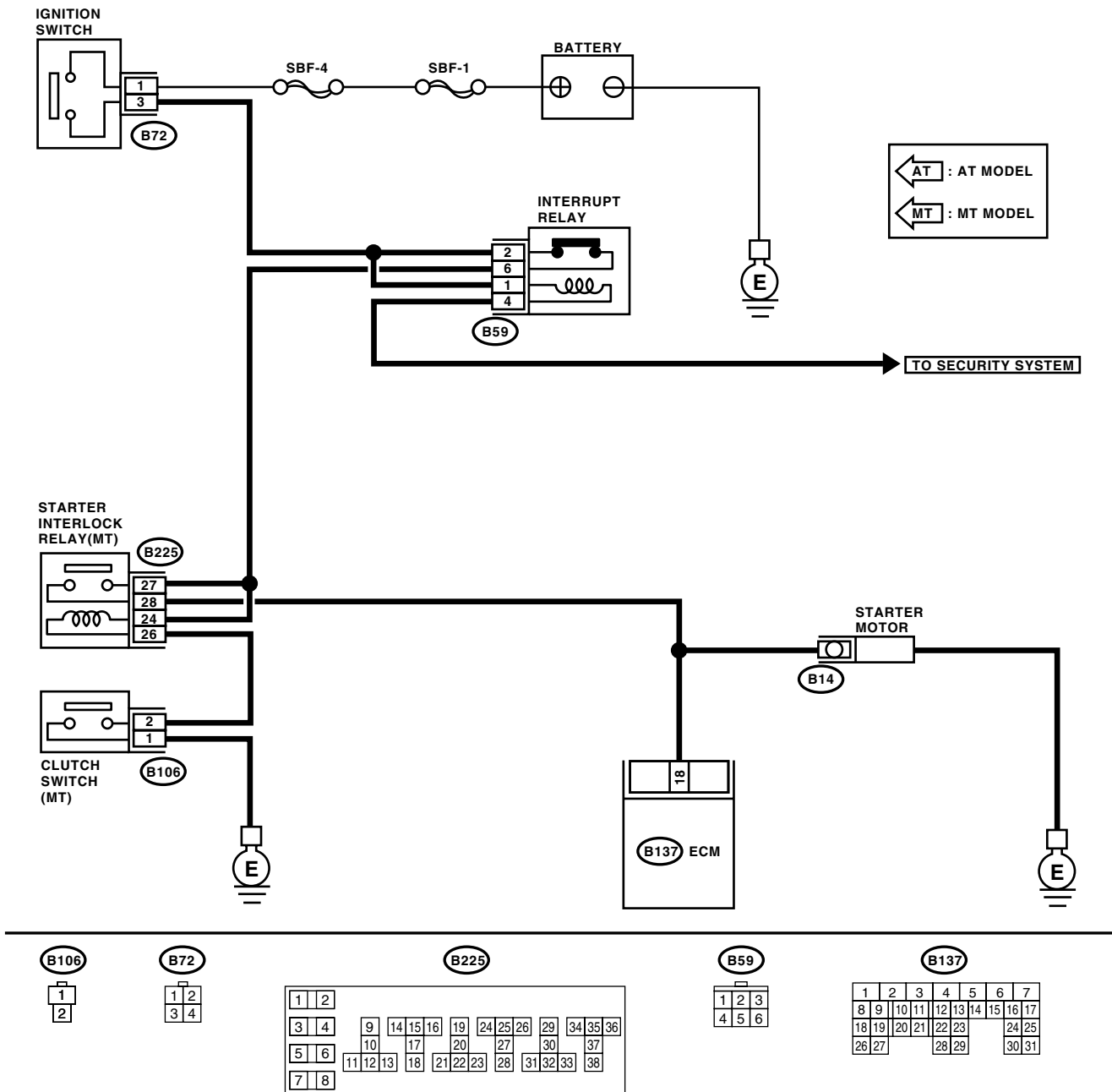

EN-01815



# DIAGNOSTIC PROCEDURE WITH DIAGNOSTIC TROUBLE CODE (DTC)

ENGINE (DIAGNOSTICS)

Step	Check	Yes	No
1 <b>CHECK OPERATION OF STARTER MOTOR.</b>	Does the starter motor operate when ignition switch is turned to START?	Repair the harness and connector.  NOTE: In this case, repair the following: <ul style="list-style-type: none"><li>• Open or ground short circuit in harness between ECM and starter motor connector</li><li>• Poor contact in ECM connector</li></ul>	Check the starter motor circuit. <Ref. to EN(STi)-55, STARTER MOTOR CIRCUIT, Diagnostics for Engine Starting Failure.>

## DIAGNOSTIC PROCEDURE WITH DIAGNOSTIC TROUBLE CODE (DTC)

ENGINE (DIAGNOSTICS)

---

### DC:DTC P1560 — BACK-UP VOLTAGE CIRCUIT MALFUNCTION —

• **DTC DETECTING CONDITION:**

- Immediately at fault recognition
- GENERAL DESCRIPTION <Ref. to GD(STi)-239, DTC P1560 — BACK-UP VOLTAGE CIRCUIT MALFUNCTION —, Diagnostic Trouble Code (DTC) Detecting Criteria.>

**CAUTION:**

After repair or replacement of faulty parts, conduct Clear Memory Mode <Ref. to EN(STi)-42, OPERATION, Clear Memory Mode.> and Inspection Mode <Ref. to EN(STi)-35, OPERATION, Inspection Mode.>.

# DIAGNOSTIC PROCEDURE WITH DIAGNOSTIC TROUBLE CODE (DTC) ENGINE (DIAGNOSTICS)

• WIRING DIAGRAM:

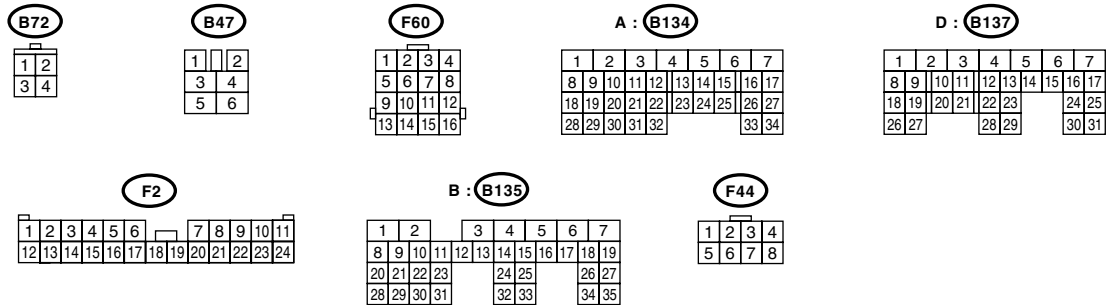
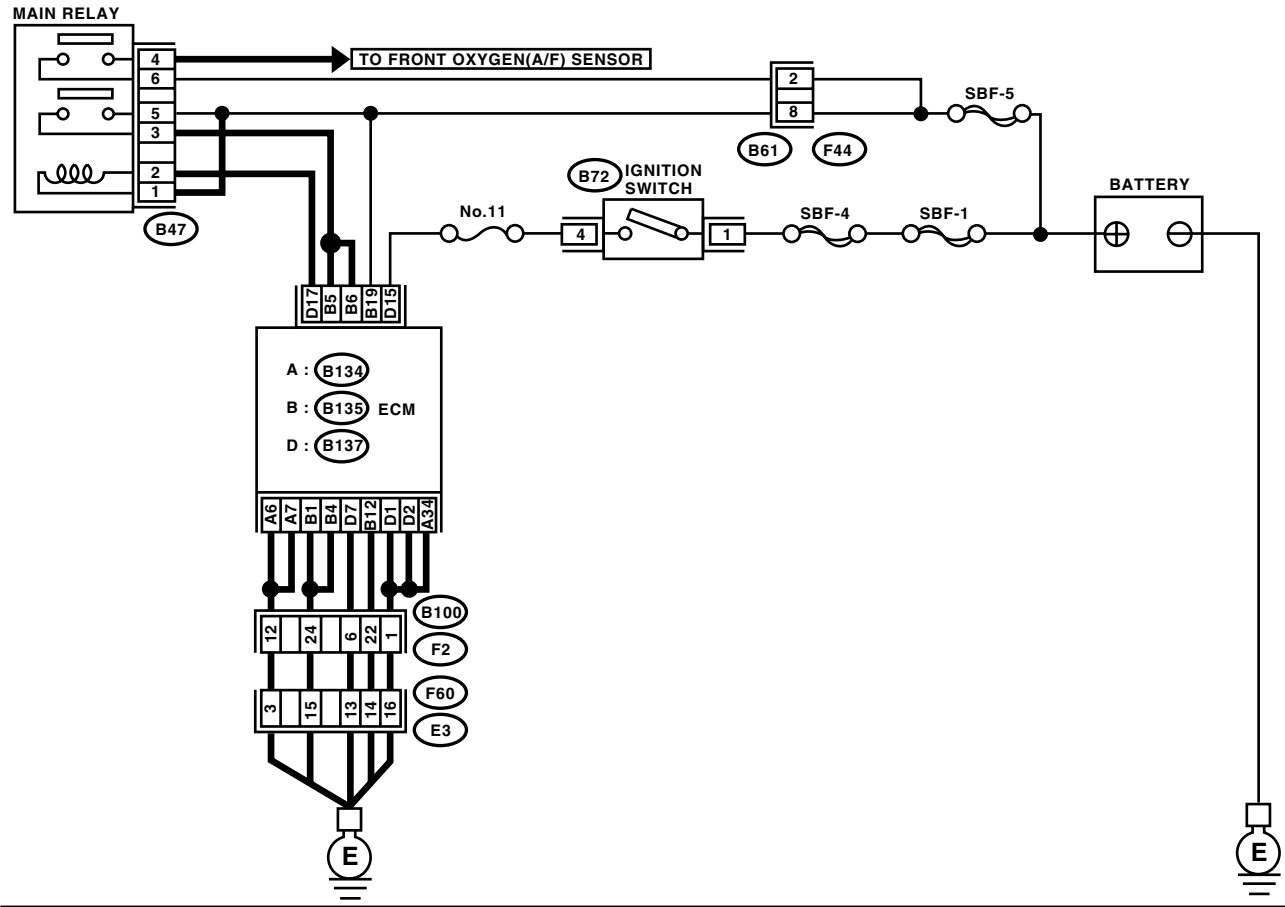

EN-01816

# DIAGNOSTIC PROCEDURE WITH DIAGNOSTIC TROUBLE CODE (DTC)

## ENGINE (DIAGNOSTICS)

Step	Check	Yes	No
<b>1 CHECK INPUT SIGNAL FOR ECM.</b> 1) Turn the ignition switch to OFF. 2) Measure the voltage between ECM and chassis ground. <i><b>Connector &amp; terminal</b></i> <i><b>(B135) No. 19 (+) — Chassis ground (-):</b></i>	Is the voltage more than 10 V?	Repair the poor contact in ECM connector.	Go to step 2.
<b>2 CHECK HARNESS BETWEEN ECM AND MAIN FUSE BOX CONNECTOR.</b> 1) Disconnect the connector from ECM. 2) Measure the resistance of harness between ECM and chassis ground. <i><b>Connector &amp; terminal</b></i> <i><b>(B135) No. 19 — Chassis ground:</b></i>	Is the resistance less than 10 $\Omega$ ?	Repair the ground short circuit in harness between ECM connector and battery terminal.	Go to step 3.
<b>3 CHECK FUSE SBF-5.</b>	Is the fuse blown?	Replace the fuse.	Repair the harness and connector.  NOTE: In this case, repair the following: <ul style="list-style-type: none"> <li>• Open circuit in harness between ECM and battery</li> <li>• Poor contact in ECM connector</li> <li>• Poor contact in battery terminal</li> </ul>

# DIAGNOSTIC PROCEDURE WITH DIAGNOSTIC TROUBLE CODE (DTC)

ENGINE (DIAGNOSTICS)

## DD:DTC P2088 — OCV SOLENOID VALVE SIGNAL A CIRCUIT OPEN (BANK 1)

**DTC DETECTING CONDITION:**

- Two consecutive driving cycles with fault
- GENERAL DESCRIPTION <Ref. to GD(STi)-240, DTC P2088 — OCV SOLENOID VALVE SIGNAL A CIRCUIT OPEN (BANK 1) —, Diagnostic Trouble Code (DTC) Detecting Criteria.>

**TROUBLE SYMPTOM:**

- Erroneous idling

**CAUTION:**

After repair or replacement of faulty parts, conduct Clear Memory Mode <Ref. to EN(STi)-42, OPERATION, Clear Memory Mode.> and Inspection Mode <Ref. to EN(STi)-35, OPERATION, Inspection Mode.>.

**WIRING DIAGRAM:**

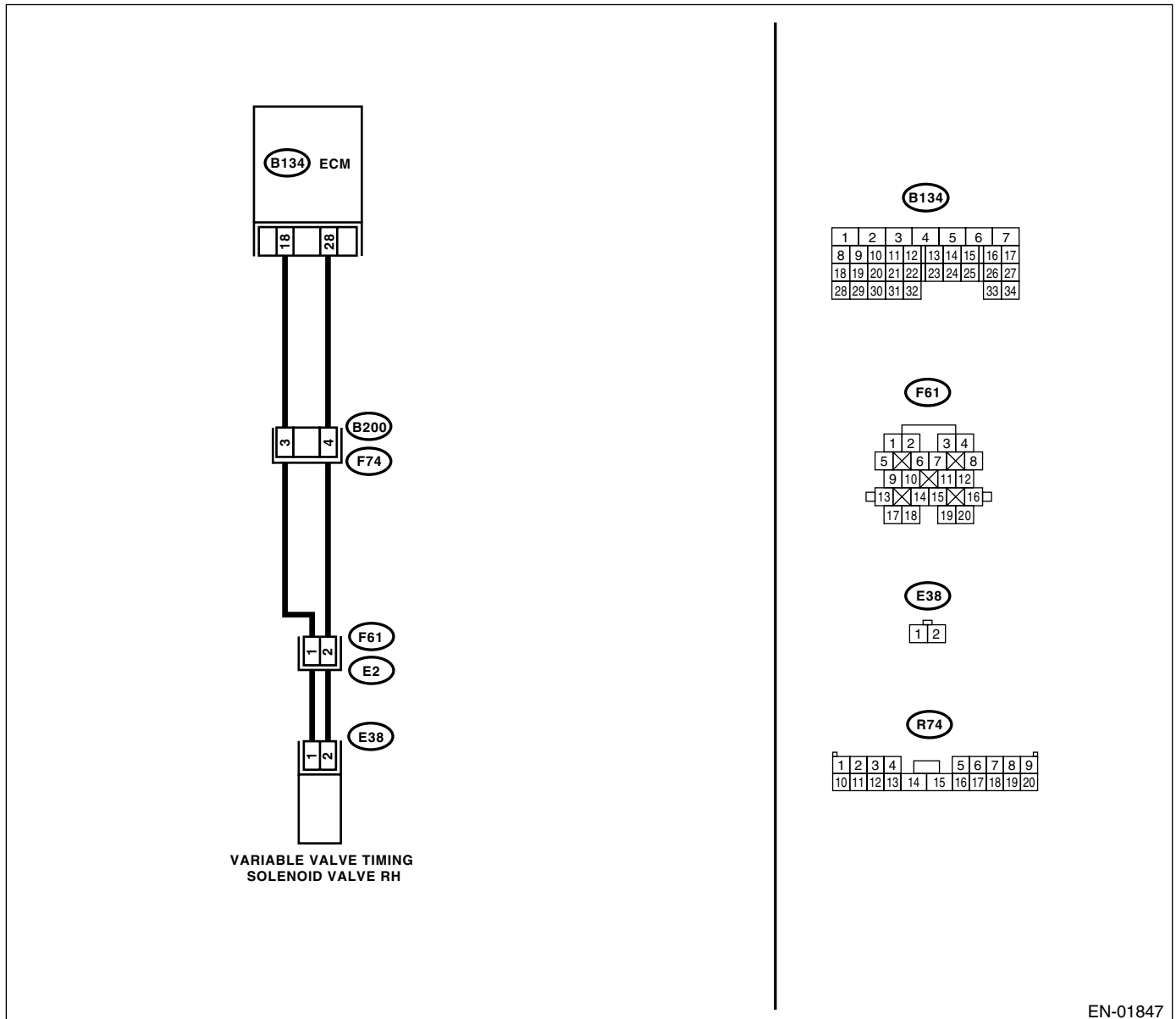

EN-01847

# DIAGNOSTIC PROCEDURE WITH DIAGNOSTIC TROUBLE CODE (DTC)

ENGINE (DIAGNOSTICS)

Step	Check	Yes	No
<p><b>1</b></p> <p><b>CHECK HARNESS BETWEEN ECM AND VARIABLE VALVE TIMING SOLENOID VALVE.</b></p> <p>1) Turn the ignition switch to OFF. 2) Disconnect the connector from ECM and variable valve timing solenoid valve. 3) Measure the resistance between ECM and variable valve timing solenoid valve.</p> <p><b>Connector &amp; terminal</b> <b>(B134) No. 18 — (E38) No. 1:</b> <b>(B134) No. 28 — (E38) No. 2:</b></p>	<p>Is the resistance less than 1 <math>\Omega</math>?</p>	<p>Go to step 2.</p>	<p>Repair the open circuit in harness between ECM and variable valve timing solenoid valve connector.</p> <p><b>NOTE:</b> In this case, repair the following:</p> <ul style="list-style-type: none"> <li>• Open circuit in harness between ECM and variable valve timing solenoid valve connector</li> <li>• Poor contact in coupling connector.</li> </ul>
<p><b>2</b></p> <p><b>CHECK HARNESS BETWEEN ECM AND VARIABLE VALVE TIMING SOLENOID VALVE.</b></p> <p>Measure the resistance between ECM and variable valve timing solenoid valve.</p> <p><b>Connector &amp; terminal</b> <b>(E38) No. 1 — Engine ground:</b> <b>(E38) No. 2 — Engine ground:</b></p>	<p>Is the resistance more than 1 <math>M\Omega</math>?</p>	<p>Go to step 3.</p>	<p>Repair the short circuit between ECM and variable valve timing solenoid valve connector.</p>
<p><b>3</b></p> <p><b>CHECK VARIABLE VALVE TIMING SOLENOID VALVE.</b></p> <p>1) Remove the variable valve timing solenoid valve. 2) Measure the resistance between variable valve timing solenoid valve terminal.</p> <p><b>Terminals</b> <b>No. 1 — No. 2:</b></p>	<p>Is the resistance 6 — 12 <math>\Omega</math>?</p>	<p>Repair the poor contact in ECM and variable valve timing solenoid valve.</p>	<p>Replace the variable valve timing solenoid valve. &lt;Ref. to ME(STi)-57, Camshaft.&gt;</p>

# DIAGNOSTIC PROCEDURE WITH DIAGNOSTIC TROUBLE CODE (DTC)

ENGINE (DIAGNOSTICS)

## DE:DTC P2089 — OCV SOLENOID VALVE SIGNAL A CIRCUIT SHORT (BANK 1)

### • DTC DETECTING CONDITION:

- Two consecutive driving cycles with fault
- GENERAL DESCRIPTION <Ref. to GD(STi)-242, DTC P2089 — OCV SOLENOID VALVE SIGNAL A CIRCUIT SHORT (BANK 1) —, Diagnostic Trouble Code (DTC) Detecting Criteria.>

### • TROUBLE SYMPTOM:

- Erroneous idling

### CAUTION:

After repair or replacement of faulty parts, conduct Clear Memory Mode <Ref. to EN(STi)-42, OPERATION, Clear Memory Mode.> and Inspection Mode <Ref. to EN(STi)-35, OPERATION, Inspection Mode.>.

### • WIRING DIAGRAM:

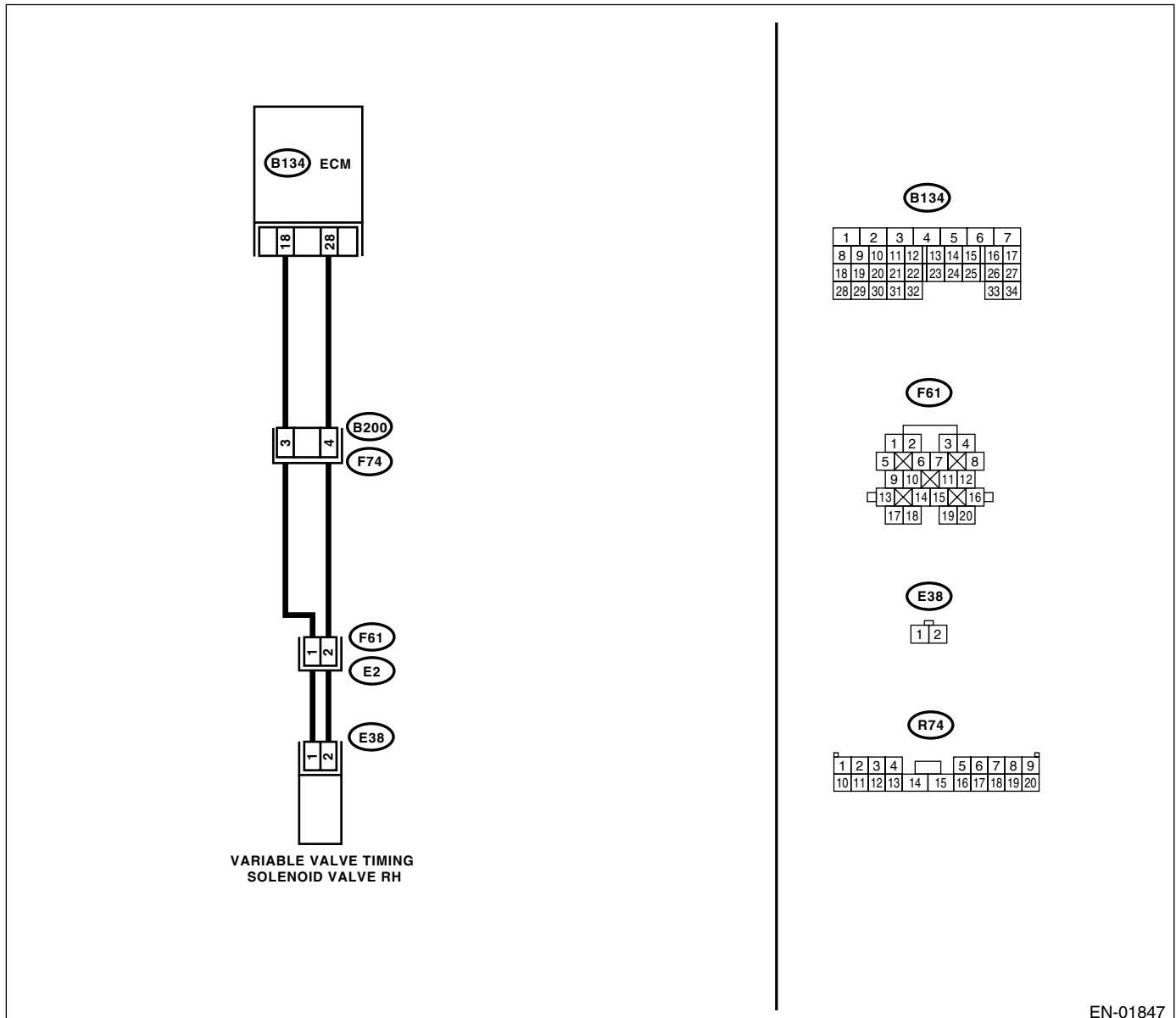

EN-01847

# DIAGNOSTIC PROCEDURE WITH DIAGNOSTIC TROUBLE CODE (DTC)

ENGINE (DIAGNOSTICS)

Step	Check	Yes	No
<p><b>1</b></p> <p><b>CHECK HARNESS BETWEEN ECM AND VARIABLE VALVE TIMING SOLENOID VALVE.</b></p> <p>1) Turn the ignition switch to OFF.                      2) Disconnect the connector from ECM and variable valve timing solenoid valve.                      3) Measure the resistance between ECM and variable valve timing solenoid valve.</p> <p><b>Connector &amp; terminal</b>                      (B134) No. 18 — (E38) No. 1:                      (B134) No. 28 — (E38) No. 2:</p>	<p>Is the resistance less than 1 <math>\Omega</math>?</p>	<p>Go to step 2.</p>	<p>Repair the open circuit in harness between ECM and variable valve timing solenoid valve connector.</p> <p><b>NOTE:</b>                      In this case, repair the following:</p> <ul style="list-style-type: none"> <li>• Open circuit in harness between ECM and variable valve timing solenoid valve connector</li> <li>• Poor contact in coupling connector.</li> </ul>
<p><b>2</b></p> <p><b>CHECK HARNESS BETWEEN ECM AND VARIABLE VALVE TIMING SOLENOID VALVE.</b></p> <p>1) Turn the ignition switch to OFF.                      2) Disconnect the connector from ECM and variable valve timing solenoid valve.                      3) Measure the resistance between ECM and variable valve timing solenoid valve.</p> <p><b>Connector &amp; terminal</b>                      (E38) No. 1 — Engine ground:                      (E38) No. 2 — Engine ground:</p>	<p>Is the resistance more than 1 M<math>\Omega</math>?</p>	<p>Go to step 3.</p>	<p>Repair the short circuit between ECM and variable valve timing solenoid valve connector.</p>
<p><b>3</b></p> <p><b>CHECK VARIABLE VALVE TIMING SOLENOID VALVE.</b></p> <p>1) Remove the variable valve timing solenoid valve.                      2) Measure the resistance between variable valve timing solenoid valve terminal.</p> <p><b>Terminals</b>                      No. 1 — No. 2:</p>	<p>Is the resistance 6 — 12 <math>\Omega</math>?</p>	<p>Repair the poor contact in ECM and variable valve timing solenoid valve.</p>	<p>Replace the variable valve timing solenoid valve.                      &lt;Ref. to ME(STi)-57, Camshaft.&gt;</p>



**DF:DTC P2092 — OCV SOLENOID VALVE SIGNAL A CIRCUIT OPEN (BANK 2)**

**DTC DETECTING CONDITION:**

- Two consecutive driving cycles with fault
- GENERAL DESCRIPTION <Ref. to GD(STi)-244, DTC P2092 — OCV SOLENOID VALVE SIGNAL A CIRCUIT OPEN (BANK 2) —, Diagnostic Trouble Code (DTC) Detecting Criteria.>

**TROUBLE SYMPTOM:**

- Erroneous idling

**CAUTION:**

After repair or replacement of faulty parts, conduct Clear Memory Mode <Ref. to EN(STi)-42, OPERATION, Clear Memory Mode.> and Inspection Mode <Ref. to EN(STi)-35, OPERATION, Inspection Mode.>.

**WIRING DIAGRAM:**

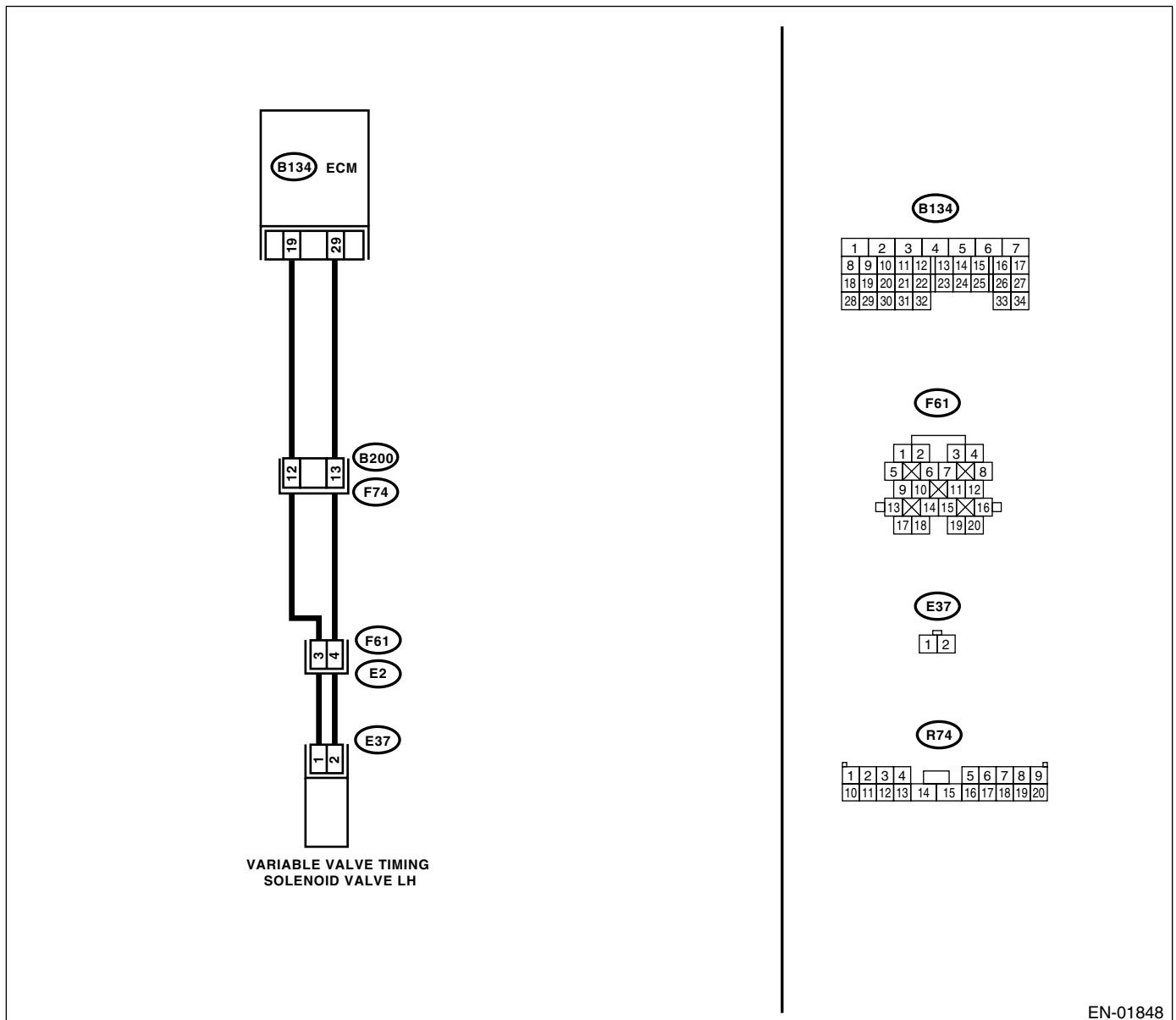

EN-01848

# DIAGNOSTIC PROCEDURE WITH DIAGNOSTIC TROUBLE CODE (DTC)

ENGINE (DIAGNOSTICS)

	Step	Check	Yes	No
1	<p><b>CHECK HARNESS BETWEEN ECM AND VARIABLE VALVE TIMING SOLENOID VALVE.</b></p> <p>1) Turn the ignition switch to OFF.                      2) Disconnect the connector from ECM and variable valve timing solenoid valve.                      3) Measure the resistance between ECM and variable valve timing solenoid valve.</p> <p><b>Connector &amp; terminal</b>                      (B134) No. 19 — (E37) No. 1:                      (B134) No. 29 — (E37) No. 2:</p>	<p>Is the resistance less than 1 <math>\Omega</math>?</p>	<p>Go to step 2.</p>	<p>Repair the open circuit in harness between ECM and variable valve timing solenoid valve connector.</p> <p><b>NOTE:</b>                      In this case, repair the following:</p> <ul style="list-style-type: none"> <li>• Open circuit in harness between ECM and variable valve timing solenoid valve connector</li> <li>• Poor contact in coupling connector.</li> </ul>
2	<p><b>CHECK HARNESS BETWEEN ECM AND VARIABLE VALVE TIMING SOLENOID VALVE.</b></p> <p>Measure the resistance between ECM and variable valve timing solenoid valve.</p> <p><b>Connector &amp; terminal</b>                      (E37) No. 1 — Engine ground:                      (E37) No. 2 — Engine ground:</p>	<p>Is the resistance more than 1 M<math>\Omega</math>?</p>	<p>Go to step 3.</p>	<p>Repair the short circuit between ECM and variable valve timing solenoid valve connector.</p>
3	<p><b>CHECK VARIABLE VALVE TIMING SOLENOID VALVE.</b></p> <p>1) Remove the variable valve timing solenoid valve.                      2) Measure the resistance between variable valve timing solenoid valve terminal.</p> <p><b>Terminals</b>                      No. 1 — No. 2:</p>	<p>Is the resistance 6 — 12 <math>\Omega</math>?</p>	<p>Repair the poor contact in ECM and variable valve timing solenoid valve.</p>	<p>Replace the variable valve timing solenoid valve.                      &lt;Ref. to ME(STi)-57, Camshaft.&gt;</p>

# DIAGNOSTIC PROCEDURE WITH DIAGNOSTIC TROUBLE CODE (DTC)

ENGINE (DIAGNOSTICS)

## DG:DTC P2093 — OCV SOLENOID VALVE SIGNAL A CIRCUIT SHORT (BANK 2)

### DTC DETECTING CONDITION:

- Two consecutive driving cycles with fault
- GENERAL DESCRIPTION <Ref. to GD(STi)-246, DTC P2093 — OCV SOLENOID VALVE SIGNAL A CIRCUIT SHORT (BANK 2) —, Diagnostic Trouble Code (DTC) Detecting Criteria.>

### TROUBLE SYMPTOM:

- Erroneous idling

### CAUTION:

After repair or replacement of faulty parts, conduct Clear Memory Mode <Ref. to EN(STi)-42, OPERATION, Clear Memory Mode.> and Inspection Mode <Ref. to EN(STi)-35, OPERATION, Inspection Mode.>.

### WIRING DIAGRAM:

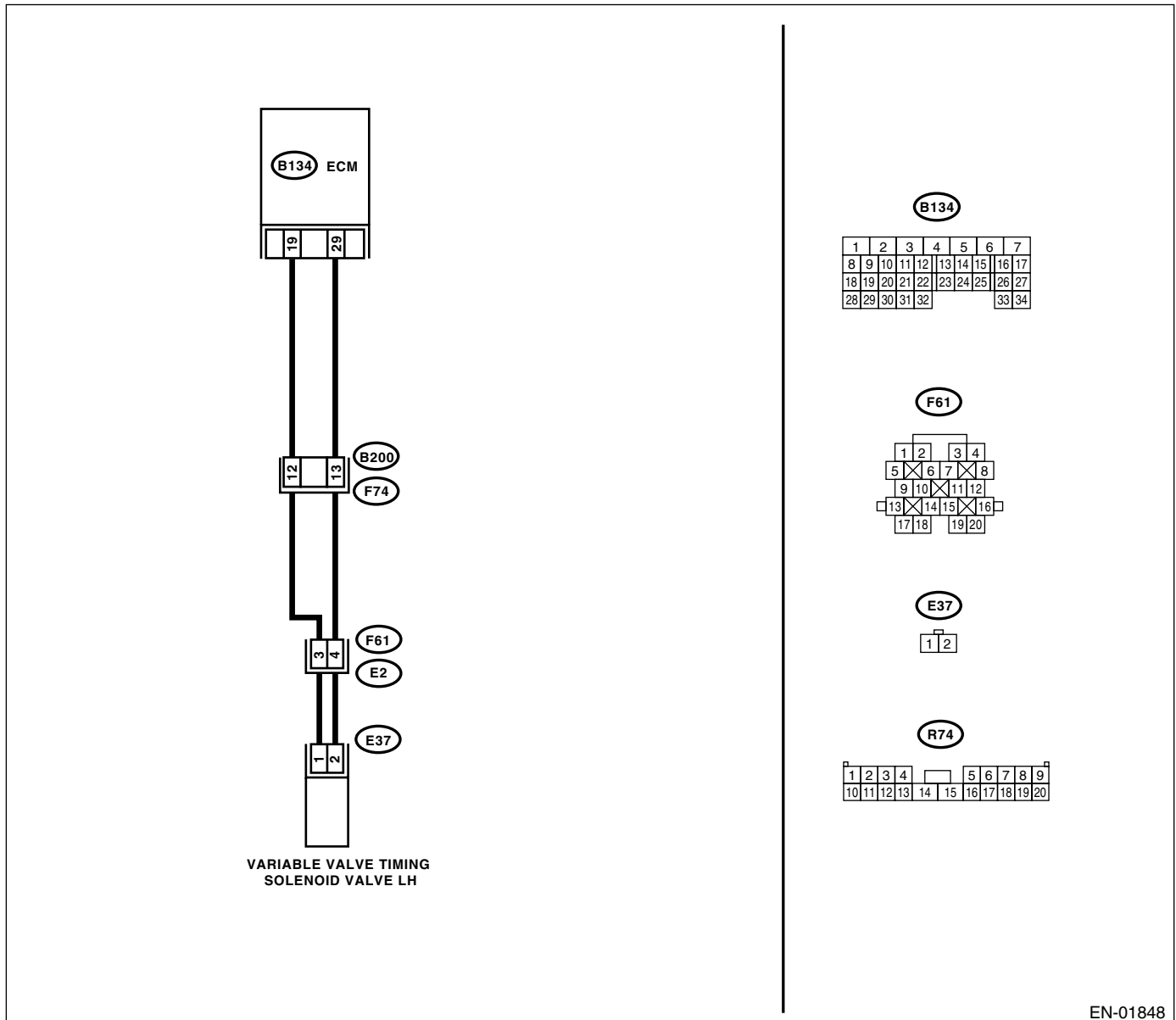

EN-01848

# DIAGNOSTIC PROCEDURE WITH DIAGNOSTIC TROUBLE CODE (DTC)

ENGINE (DIAGNOSTICS)

Step	Check	Yes	No
<p><b>1</b></p> <p><b>CHECK HARNESS BETWEEN ECM AND VARIABLE VALVE TIMING SOLENOID VALVE.</b></p> <p>1) Turn the ignition switch to OFF.                      2) Disconnect the connector from ECM and variable valve timing solenoid valve.                      3) Measure the resistance between ECM and variable valve timing solenoid valve.</p> <p><b>Connector &amp; terminal</b>                      (B134) No. 19 — (E37) No. 1:                      (B134) No. 29 — (E37) No. 2:</p>	<p>Is the resistance less than 1 <math>\Omega</math>?</p>	<p>Go to step 2.</p>	<p>Repair the open circuit in harness between ECM and variable valve timing solenoid valve connector.</p> <p><b>NOTE:</b>                      In this case, repair the following:</p> <ul style="list-style-type: none"> <li>• Open circuit in harness between ECM and variable valve timing solenoid valve connector</li> <li>• Poor contact in coupling connector.</li> </ul>
<p><b>2</b></p> <p><b>CHECK HARNESS BETWEEN ECM AND VARIABLE VALVE TIMING SOLENOID VALVE.</b></p> <p>1) Turn the ignition switch to OFF.                      2) Disconnect the connector from ECM and variable valve timing solenoid valve.                      3) Measure the resistance between ECM and variable valve timing solenoid valve.</p> <p><b>Connector &amp; terminal</b>                      (E37) No. 1 — Engine ground:                      (E37) No. 2 — Engine ground:</p>	<p>Is the resistance more than 1 M<math>\Omega</math>?</p>	<p>Go to step 3.</p>	<p>Repair the short circuit between ECM and variable valve timing solenoid valve connector.</p>
<p><b>3</b></p> <p><b>CHECK VARIABLE VALVE TIMING SOLENOID VALVE.</b></p> <p>1) Remove the variable valve timing solenoid valve.                      2) Measure the resistance between variable valve timing solenoid valve terminal.</p> <p><b>Terminals</b>                      No. 1 — No. 2:</p>	<p>Is the resistance 6 — 12 <math>\Omega</math>?</p>	<p>Repair the poor contact in ECM and variable valve timing solenoid valve.</p>	<p>Replace the variable valve timing solenoid valve.                      &lt;Ref. to ME(STi)-57, Camshaft.&gt;</p>

# DIAGNOSTIC PROCEDURE WITH DIAGNOSTIC TROUBLE CODE (DTC)

ENGINE (DIAGNOSTICS)

## DH:DTC P2096 — POST CATALYST FUEL TRIM SYSTEM TOO LEAN BANK 1

### • DTC DETECTING CONDITION:

- Two consecutive driving cycles with fault
- GENERAL DESCRIPTION <Ref. to GD(STi)-248, DTC P2096 — POST CATALYST FUEL TRIM SYSTEM TOO LEAN BANK 1 —, Diagnostic Trouble Code (DTC) Detecting Criteria.>

### CAUTION:

After repair or replacement of faulty parts, conduct Clear Memory Mode <Ref. to EN(STi)-42, OPERATION, Clear Memory Mode.> and Inspection Mode <Ref. to EN(STi)-35, OPERATION, Inspection Mode.>.

### • WIRING DIAGRAM:

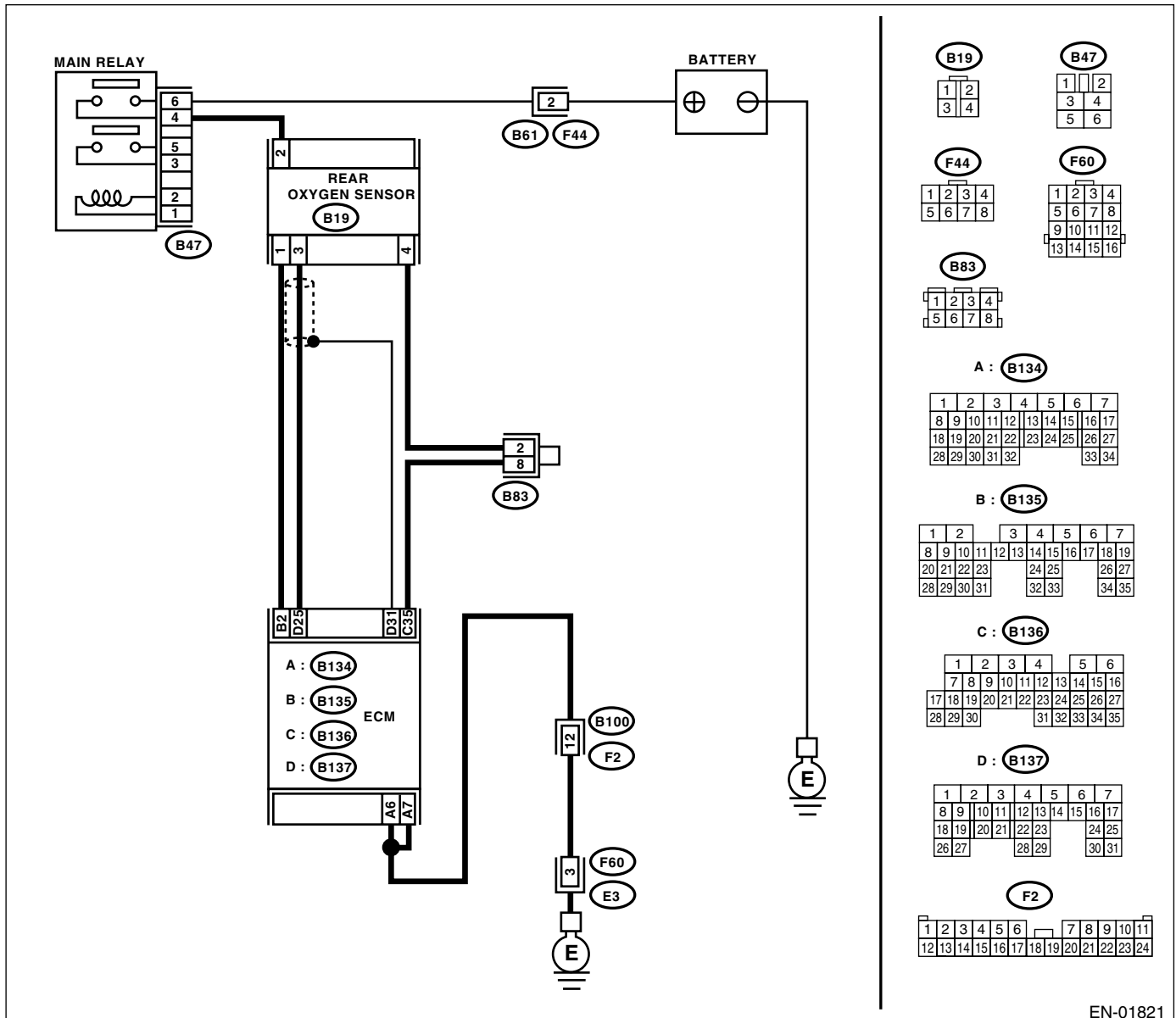

EN-01821

# DIAGNOSTIC PROCEDURE WITH DIAGNOSTIC TROUBLE CODE (DTC)

## ENGINE (DIAGNOSTICS)

	Step	Check	Yes	No
1	<b>CHECK ANY OTHER DTC ON DISPLAY.</b>	Is any other DTC displayed?	Using the List of Diagnostic Trouble Code (DTC), check the appropriate DTC. <Ref. to EN(STi)-66, List of Diagnostic Trouble Code (DTC).>	Go to step 2.
2	<b>CHECK REAR OXYGEN SENSOR DATA.</b> 1) Warm-up the engine until engine coolant temperature is above 70°C (158°F), and keep the engine speed at 2,000 rpm to 3,000 rpm for 2 minutes. 2) Read the data of rear oxygen sensor signal using Subaru Select Monitor or OBD-II general scan tool. <b>NOTE:</b> • Subaru Select Monitor For detailed operation procedure, refer to the "READ CURRENT DATA SHOWN ON DISPLAY FOR ENGINE". <Ref. to EN(STi)-28, Subaru Select Monitor.> • OBD-II general scan tool For detailed operation procedures, refer to the OBD-II General Scan Tool Instruction Manual.	Does the value fluctuate?	Go to step 6.	Go to step 3.
3	<b>CHECK REAR OXYGEN SENSOR DATA.</b> Read the data of rear oxygen sensor signal using Subaru Select Monitor or OBD-II general scan tool.	Is the voltage 0.2 — 0.4 V?	Go to step 4.	Replace the rear oxygen sensor. <Ref. to FU(STi)-39, Rear Oxygen Sensor.>
4	<b>CHECK HARNESS BETWEEN ECM AND REAR OXYGEN SENSOR CONNECTOR.</b> 1) Turn the ignition switch to OFF. 2) Disconnect the connectors from ECM and rear oxygen sensor. 3) Measure the resistance of harness between ECM and rear oxygen sensor connector. <b>Connector &amp; terminal</b> <b>(B137) No. 25 — (B19) No. 3:</b>	Is the resistance more than 3 Ω?	Repair the open circuit in harness between ECM and rear oxygen sensor connector.	Go to step 5.
5	<b>CHECK HARNESS BETWEEN REAR OXYGEN SENSOR AND ECM CONNECTOR.</b> 1) Turn the ignition switch to OFF. 2) Disconnect the connector from rear oxygen sensor. 3) Turn the ignition switch to ON. 4) Measure the voltage between rear oxygen sensor harness connector and engine ground or chassis ground. <b>Connector &amp; terminal</b> <b>(B19) No. 3 (+) — Engine ground (-):</b>	Is the voltage more than 0.2 V?	Replace the rear oxygen sensor. <Ref. to FU(STi)-39, Rear Oxygen Sensor.>	Repair the harness and connector. <b>NOTE:</b> In this case, repair the following: • Open circuit in harness between rear oxygen sensor and ECM connector • Poor contact in rear oxygen sensor connector • Poor contact in ECM connector

# DIAGNOSTIC PROCEDURE WITH DIAGNOSTIC TROUBLE CODE (DTC)

## ENGINE (DIAGNOSTICS)

Step	Check	Yes	No
<b>6 CHECK EXHAUST SYSTEM.</b> Check the exhaust system parts. NOTE: Check the following items. <ul style="list-style-type: none"> <li>• Loose installation of portions</li> <li>• Damage (crack, hole etc.) of parts</li> <li>• Looseness and ill fitting of parts between front oxygen (A/F) sensor and rear oxygen sensor</li> </ul>	Is there a fault in exhaust system?	Repair or replace the faulty parts.	Go to step 7.
<b>7 CHECK AIR INTAKE SYSTEM.</b>	Are there holes, loose bolts or disconnection of hose on air intake system?	Repair the air intake system.	Go to step 8.
<b>8 CHECK FUEL PRESSURE.</b> <b>Warning:</b> • Place “NO FIRE” signs near the working area. • Be careful not to spill fuel on the floor. 1) Release the fuel pressure. <ol style="list-style-type: none"> <li>(1) Disconnect the connector from fuel pump relay.</li> <li>(2) Start the engine and run it until it stalls.</li> <li>(3) After the engine stalls, crank it for 5 more seconds.</li> <li>(4) Turn the ignition switch to OFF.</li> </ol> 2) Connect the connector to fuel pump relay. 3) Disconnect the fuel delivery hose from fuel filter, and connect fuel pressure gauge. 4) Install the fuel filler cap. 5) Start the engine and idle while gear position is neutral. 6) Measure the fuel pressure while disconnecting pressure regulator vacuum hose from intake manifold. <b>Warning:</b> Before removing the fuel pressure gauge, release fuel pressure. NOTE: If the fuel pressure does not increase, squeeze fuel return hose 2 to 3 times, then measure fuel pressure again.	Is the measured value 284 — 314 kPa (2.9 — 3.2 kg/cm <sup>2</sup> , 41 — 46 psi)?	Go to step 9.	Repair the following items. Fuel pressure too high: <ul style="list-style-type: none"> <li>• Clogged fuel return line or bent hose</li> </ul> Fuel pressure too low: <ul style="list-style-type: none"> <li>• Improper fuel pump discharge</li> <li>• Clogged fuel supply line</li> </ul>
<b>9 CHECK FUEL PRESSURE.</b> After connecting the pressure regulator vacuum hose, measure fuel pressure. <b>Warning:</b> Before removing the fuel pressure gauge, release fuel pressure. NOTE: • If the fuel pressure does not increase, squeeze fuel return hose 2 to 3 times, then measure fuel pressure again. • If out of specification as measured at this step, check or replace the pressure regulator and pressure regulator vacuum hose.	Is the measured value 206 — 235 kPa (2.1 — 2.4 kg/cm <sup>2</sup> , 30 — 34 psi)?	Go to step 10.	Repair the following items. Fuel pressure too high: <ul style="list-style-type: none"> <li>• Faulty pressure regulator</li> <li>• Clogged fuel return line or bent hose</li> </ul> Fuel pressure too low: <ul style="list-style-type: none"> <li>• Faulty pressure regulator</li> <li>• Improper fuel pump discharge</li> <li>• Clogged fuel supply line</li> </ul>

# DIAGNOSTIC PROCEDURE WITH DIAGNOSTIC TROUBLE CODE (DTC)

## ENGINE (DIAGNOSTICS)

Step	Check	Yes	No
<p><b>10 CHECK ENGINE COOLANT TEMPERATURE SENSOR.</b></p> <p>1) Start the engine and warm-up completely. 2) Read the data of engine coolant temperature sensor signal using Subaru Select Monitor or OBD-II general scan tool.</p> <p>NOTE: • Subaru Select Monitor For detailed operation procedure, refer to the "READ CURRENT DATA FOR ENGINE". &lt;Ref. to EN(STi)-28, Subaru Select Monitor.&gt; • OBD-II general scan tool For detailed operation procedures, refer to the OBD-II General Scan Tool Instruction Manual.</p>	<p>Is the temperature more than 60°C (140°F)?</p>	<p>Go to step 11.</p>	<p>Replace the engine coolant temperature sensor. &lt;Ref. to FU(STi)-26, Engine Coolant Temperature Sensor.&gt;</p>
<p><b>11 CHECK MASS AIR FLOW AND INTAKE AIR TEMPERATURE.</b></p> <p>1) Start the engine and warm-up engine until coolant temperature is greater than 60°C (140°F). 2) Place the shift lever in neutral position. 3) Turn the A/C switch to OFF. 4) Turn all accessory switches to OFF. 5) Read the data of mass air flow and intake air temperature sensor signal using Subaru Select Monitor or OBD-II general scan tool.</p> <p>NOTE: • Subaru Select Monitor For detailed operation procedure, refer to the "READ CURRENT DATA FOR ENGINE". &lt;Ref. to EN(STi)-28, Subaru Select Monitor.&gt; • OBD-II general scan tool For detailed operation procedure, refer to the OBD-II General Scan Tool Instruction Manual.</p>	<p>Is the measured value within the followings? Ignition ON: 73.3 — 106.6 kPa (550 — 800 mmHg, 21.65 — 31.50 inHg) Idling: 24.0 — 41.3 kPa (180 — 310 mmHg, 7.09 — 12.20 inHg)</p>	<p>Go to step 12.</p>	<p>Replace the mass air flow and intake air temperature sensor. &lt;Ref. to FU(STi)-30, Mass Air Flow and Intake Air Temperature Sensor.&gt;</p>
<p><b>12 CHECK MASS AIR FLOW AND INTAKE AIR TEMPERATURE SENSOR.</b></p> <p>1) Start the engine and warm-up engine until coolant temperature is greater than 60°C (140°F). 2) Place the shift lever in neutral position. 3) Turn the A/C switch to OFF. 4) Turn all accessory switches to OFF. 5) Open the front hood. 6) Measure the ambient temperature. 7) Read the data of mass air flow and intake air temperature sensor signal using Subaru Select Monitor or OBD-II general scan tool.</p> <p>NOTE: • Subaru Select Monitor For detailed operation procedure, refer to the "READ CURRENT DATA FOR ENGINE". &lt;Ref. to EN(STi)-28, Subaru Select Monitor.&gt; • OBD-II general scan tool For detailed operation procedure, refer to the OBD-II General Scan Tool Instruction Manual.</p>	<p>Subtract ambient temperature from intake air temperature. Is the obtained value -10°C — 50°C (14°F — 122°F)?</p>	<p>Contact your SOA Service Center. NOTE: Inspection by DTM is required, because probable cause is deterioration of multiple parts.</p>	<p>Check the mass air flow and intake air temperature sensor. &lt;Ref. to FU(STi)-30, Mass Air Flow and Intake Air Temperature Sensor.&gt;</p>



# DIAGNOSTIC PROCEDURE WITH DIAGNOSTIC TROUBLE CODE (DTC)

## ENGINE (DIAGNOSTICS)

### DI: DTC P2097 — POST CATALYST FUEL TRIM SYSTEM TOO RICH BANK 1

**DTC DETECTING CONDITION:**

- Two consecutive driving cycles with fault
- GENERAL DESCRIPTION <Ref. to GD(STi)-250, DTC P2097 — POST CATALYST FUEL TRIM SYSTEM TOO RICH BANK 1 —, Diagnostic Trouble Code (DTC) Detecting Criteria.>

**CAUTION:**

After repair or replacement of faulty parts, conduct Clear Memory Mode <Ref. to EN(STi)-42, OPERATION, Clear Memory Mode.> and Inspection Mode <Ref. to EN(STi)-35, OPERATION, Inspection Mode.>.

**• WIRING DIAGRAM:**

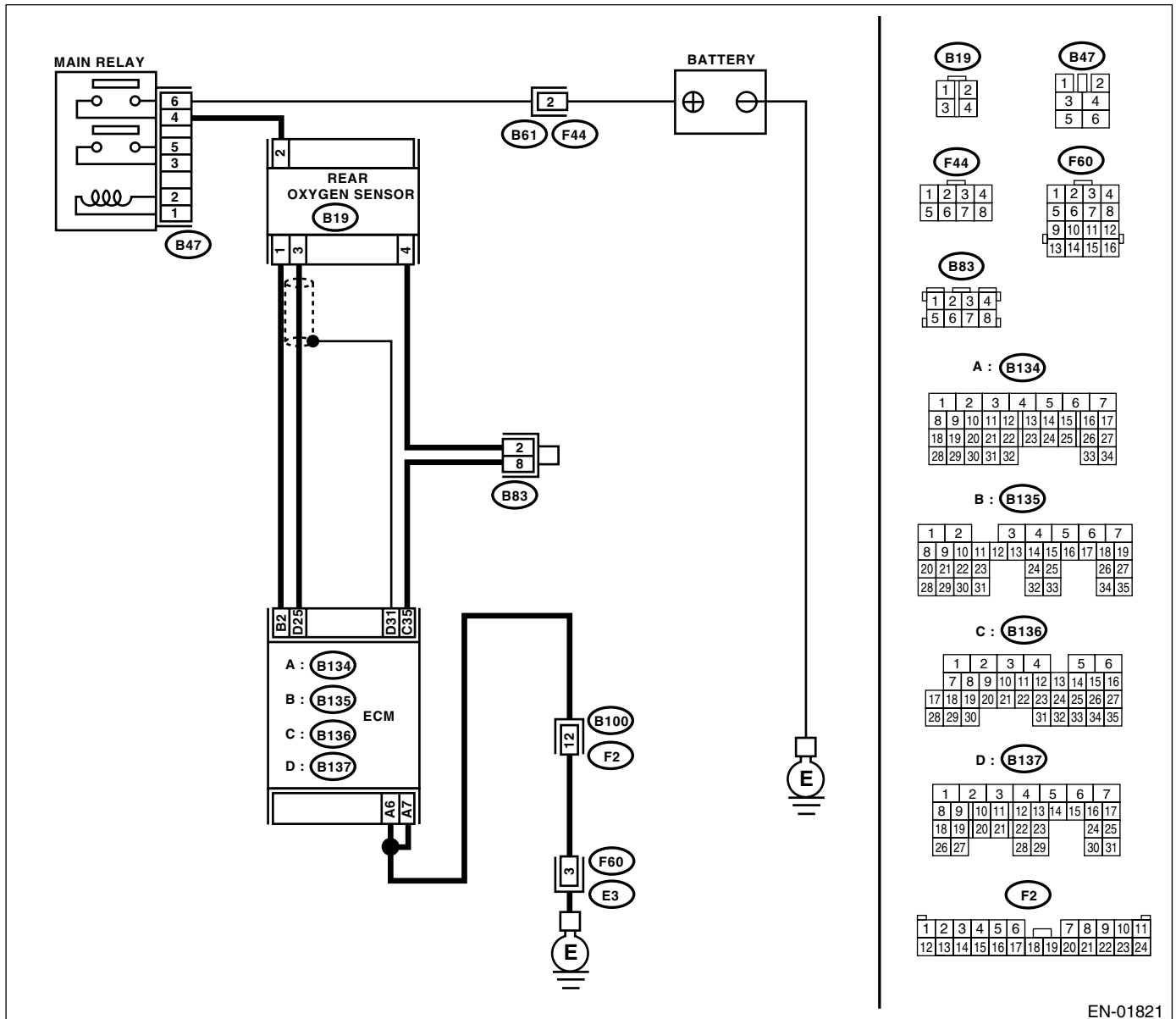

EN-01821

# DIAGNOSTIC PROCEDURE WITH DIAGNOSTIC TROUBLE CODE (DTC)

## ENGINE (DIAGNOSTICS)

	Step	Check	Yes	No
1	<b>CHECK ANY OTHER DTC ON DISPLAY.</b>	Is any other DTC displayed?	Using the List of Diagnostic Trouble Code (DTC), check the appropriate DTC. <Ref. to EN(STi)-66, List of Diagnostic Trouble Code (DTC).>	Go to step 2.
2	<b>CHECK REAR OXYGEN SENSOR DATA.</b> 1) Warm-up the engine until engine coolant temperature is above 70°C (158°F), and keep the engine speed at 2,000 rpm to 3,000 rpm for 2 minutes. 2) Read the data of rear oxygen sensor signal using Subaru Select Monitor or OBD-II general scan tool. <b>NOTE:</b> • Subaru Select Monitor For detailed operation procedure, refer to the "READ CURRENT DATA SHOWN ON DISPLAY FOR ENGINE". <Ref. to EN(STi)-28, Subaru Select Monitor.> • OBD-II general scan tool For detailed operation procedures, refer to the OBD-II General Scan Tool Instruction Manual.	Does the value fluctuate?	Go to step 6.	Go to step 3.
3	<b>CHECK REAR OXYGEN SENSOR DATA.</b> Read the data of rear oxygen sensor signal using Subaru Select Monitor or OBD-II general scan tool.	Is the voltage 0.2 — 0.4 V?	Go to step 4.	Replace the rear oxygen sensor. <Ref. to FU(STi)-39, Rear Oxygen Sensor.>
4	<b>CHECK HARNESS BETWEEN ECM AND REAR OXYGEN SENSOR CONNECTOR.</b> 1) Turn the ignition switch to OFF. 2) Disconnect the connectors from ECM and rear oxygen sensor. 3) Measure the resistance of harness between ECM and rear oxygen sensor connector. <b>Connector &amp; terminal</b> <b>(B137) No. 25 — (B19) No. 3:</b>	Is the resistance more than 3 Ω?	Repair the open circuit in harness between ECM and rear oxygen sensor connector.	Go to step 5.
5	<b>CHECK HARNESS BETWEEN REAR OXYGEN SENSOR AND ECM CONNECTOR.</b> 1) Turn the ignition switch to OFF. 2) Disconnect the connector from rear oxygen sensor. 3) Turn the ignition switch to ON. 4) Measure the voltage between rear oxygen sensor harness connector and engine ground or chassis ground. <b>Connector &amp; terminal</b> <b>(B19) No. 3 (+) — Engine ground (-):</b>	Is the voltage more than 0.2 V?	Replace the rear oxygen sensor. <Ref. to FU(STi)-39, Rear Oxygen Sensor.>	Repair the harness and connector. <b>NOTE:</b> In this case, repair the following: • Open circuit in harness between rear oxygen sensor and ECM connector • Poor contact in rear oxygen sensor connector • Poor contact in ECM connector

# DIAGNOSTIC PROCEDURE WITH DIAGNOSTIC TROUBLE CODE (DTC)

## ENGINE (DIAGNOSTICS)

Step	Check	Yes	No
<p><b>6 CHECK EXHAUST SYSTEM.</b> Check the exhaust system parts.</p> <p><b>NOTE:</b> Check the following items.</p> <ul style="list-style-type: none"> <li>•Loose installation of portions</li> <li>•Damage (crack, hole etc.) of parts</li> <li>•Looseness and ill fitting of parts between front oxygen (A/F) sensor and rear oxygen sensor</li> </ul>	Is there a fault in exhaust system?	Repair or replace the faulty parts.	Go to step 7.
<p><b>7 CHECK AIR INTAKE SYSTEM.</b></p>	Are there holes, loose bolts or disconnection of hose on air intake system?	Repair the air intake system.	Go to step 8.
<p><b>8 CHECK FUEL PRESSURE.</b></p> <p><b>Warning:</b> •Place “NO FIRE” signs near the working area. •Be careful not to spill fuel on the floor.</p> <p>1)Release the fuel pressure.     (1) Disconnect the connector from fuel pump relay.     (2) Start the engine and run it until it stalls.     (3) After the engine stalls, crank it for 5 more seconds.     (4) Turn the ignition switch to OFF.</p> <p>2)Connect the connector to fuel pump relay. 3)Disconnect the fuel delivery hose from fuel filter, and connect fuel pressure gauge. 4)Install the fuel filler cap. 5)Start the engine and idle while gear position is neutral. 6)Measure the fuel pressure while disconnecting pressure regulator vacuum hose from intake manifold.</p> <p><b>Warning:</b> <b>Before removing the fuel pressure gauge, release fuel pressure.</b></p> <p><b>NOTE:</b> If the fuel pressure does not increase, squeeze fuel return hose 2 to 3 times, then measure fuel pressure again.</p>	Is the measured value 284 — 314 kPa (2.9 — 3.2 kg/cm <sup>2</sup> , 41 — 46 psi)?	Go to step 9.	<p>Repair the following items.</p> <p>Fuel pressure too high:</p> <ul style="list-style-type: none"> <li>• Clogged fuel return line or bent hose</li> </ul> <p>Fuel pressure too low:</p> <ul style="list-style-type: none"> <li>• Improper fuel pump discharge</li> <li>• Clogged fuel supply line</li> </ul>
<p><b>9 CHECK FUEL PRESSURE.</b></p> <p>After connecting the pressure regulator vacuum hose, measure fuel pressure.</p> <p><b>Warning:</b> <b>Before removing the fuel pressure gauge, release fuel pressure.</b></p> <p><b>NOTE:</b> •If the fuel pressure does not increase, squeeze fuel return hose 2 to 3 times, then measure fuel pressure again. •If out of specification as measured at this step, check or replace the pressure regulator and pressure regulator vacuum hose.</p>	Is the measured value 206 — 235 kPa (2.1 — 2.4 kg/cm <sup>2</sup> , 30 — 34 psi)?	Go to step 10.	<p>Repair the following items.</p> <p>Fuel pressure too high:</p> <ul style="list-style-type: none"> <li>• Faulty pressure regulator</li> <li>• Clogged fuel return line or bent hose</li> </ul> <p>Fuel pressure too low:</p> <ul style="list-style-type: none"> <li>• Faulty pressure regulator</li> <li>• Improper fuel pump discharge</li> <li>• Clogged fuel supply line</li> </ul>

# DIAGNOSTIC PROCEDURE WITH DIAGNOSTIC TROUBLE CODE (DTC)

## ENGINE (DIAGNOSTICS)

Step	Check	Yes	No
<b>10 CHECK ENGINE COOLANT TEMPERATURE SENSOR.</b> 1) Start the engine and warm-up completely. 2) Read the data of engine coolant temperature sensor signal using Subaru Select Monitor or OBD-II general scan tool.  <b>NOTE:</b> •Subaru Select Monitor For detailed operation procedure, refer to the "READ CURRENT DATA FOR ENGINE". <Ref. to EN(STi)-28, Subaru Select Monitor.> •OBD-II general scan tool For detailed operation procedures, refer to the OBD-II General Scan Tool Instruction Manual.	Is the temperature more than 60°C (140°F)?	Go to step 11.	Replace the engine coolant temperature sensor. <Ref. to FU(STi)-26, Engine Coolant Temperature Sensor.>
<b>11 CHECK MASS AIR FLOW AND INTAKE AIR TEMPERATURE.</b> 1) Start the engine and warm-up engine until coolant temperature is greater than 60°C (140°F). 2) Place the shift lever in neutral position. 3) Turn the A/C switch to OFF. 4) Turn all accessory switches to OFF. 5) Read the data of mass air flow and intake air temperature sensor signal using Subaru Select Monitor or OBD-II general scan tool.  <b>NOTE:</b> •Subaru Select Monitor For detailed operation procedure, refer to the "READ CURRENT DATA FOR ENGINE". <Ref. to EN(STi)-28, Subaru Select Monitor.> •OBD-II general scan tool For detailed operation procedure, refer to the OBD-II General Scan Tool Instruction Manual.	Is the measured value within the followings? Ignition ON: 73.3 — 106.6 kPa (550 — 800 mmHg, 21.65 — 31.50 inHg) Idling: 24.0 — 41.3 kPa (180 — 310 mmHg, 7.09 — 12.20 inHg)	Go to step 12.	Replace the mass air flow and intake air temperature sensor. <Ref. to FU(STi)-30, Mass Air Flow and Intake Air Temperature Sensor.>
<b>12 CHECK MASS AIR FLOW AND INTAKE AIR TEMPERATURE SENSOR.</b> 1) Start the engine and warm-up engine until coolant temperature is greater than 60°C (140°F). 2) Place the shift lever in neutral position. 3) Turn the A/C switch to OFF. 4) Turn all accessory switches to OFF. 5) Open the front hood. 6) Measure the ambient temperature. 7) Read the data of mass air flow and intake air temperature sensor signal using Subaru Select Monitor or OBD-II general scan tool.  <b>NOTE:</b> •Subaru Select Monitor For detailed operation procedure, refer to the "READ CURRENT DATA FOR ENGINE". <Ref. to EN(STi)-28, Subaru Select Monitor.> •OBD-II general scan tool For detailed operation procedure, refer to the OBD-II General Scan Tool Instruction Manual.	Subtract ambient temperature from intake air temperature. Is the obtained value -10°C — 50°C (14°F — 122°F)?	Contact your SOA Service Center.  <b>NOTE:</b> Inspection by DTM is required, because probable cause is deterioration of multiple parts.	Check the mass air flow and intake air temperature sensor. <Ref. to FU(STi)-30, Mass Air Flow and Intake Air Temperature Sensor.>

## DIAGNOSTIC PROCEDURE WITH DIAGNOSTIC TROUBLE CODE (DTC)

ENGINE (DIAGNOSTICS)

### DJ:DTC P2101 — THROTTLE ACTUATOR CONTROL MOTOR CIRCUIT RANGE/ PERFORMANCE —

#### • DTC DETECTING CONDITION:

- Immediately at fault recognition
- GENERAL DESCRIPTION <Ref. to GD(STi)-187, DTC P0638 — THROTTLE ACTUATOR CONTROL RANGE/PERFORMANCE (BANK 1) —, Diagnostic Trouble Code (DTC) Detecting Criteria.>, <Ref. to GD(STi)-222, DTC P1160 — RETURN SPRING FAILURE —, Diagnostic Trouble Code (DTC) Detecting Criteria.> and <Ref. to GD(STi)-252, DTC P2101 — THROTTLE ACTUATOR CONTROL MOTOR CIRCUIT RANGE/PERFORMANCE —, Diagnostic Trouble Code (DTC) Detecting Criteria.>

#### • TROUBLE SYMPTOM:

- Erroneous idling
- Poor driving performance
- Engine stalls.



# DIAGNOSTIC PROCEDURE WITH DIAGNOSTIC TROUBLE CODE (DTC)

## ENGINE (DIAGNOSTICS)

Step	Check	Yes	No
<b>1 CHECK ELECTRIC THROTTLE RELAY.</b> 1) Turn the ignition switch to OFF. 2) Remove the electric throttle relay. 3) Connect the battery to electric throttle relay terminal No. 1 and No. 3. 4) Measure the resistance between electric throttle relay terminals. <i>Terminals</i> <i>No. 2 — No. 4:</i>	Is the resistance less than 1 $\Omega$ ?	Go to step 2.	Replace the electric throttle relay.
<b>2 CHECK POWER SUPPLY TO ELECTRIC THROTTLE RELAY.</b> Measure the voltage between electric throttle relay connector and engine ground. <i>Connector &amp; terminal</i> <i>(B309) No. 1 (+) — Engine ground (-):</i> <i>(B309) No. 2 (+) — Engine ground (-):</i>	Is the voltage more than 5 V?	Go to step 3.	Repair the open power supply circuit or ground short.
<b>3 CHECK HARNESS BETWEEN ECM AND ELECTRIC THROTTLE.</b> 1) Disconnect the connector from ECM. 2) Turn the ignition switch to ON. 3) Measure the voltage between electric throttle relay connector and engine ground. <i>Connector &amp; terminal</i> <i>(B309) No. 3 (+) — Engine ground (-):</i>	Is the voltage less than 5 V?	Go to step 4.	Repair short of the power supply circuit between ECM and electric throttle.
<b>4 CHECK HARNESS BETWEEN ECM AND ELECTRIC THROTTLE.</b> 1) Turn the ignition switch to OFF. 2) Measure the resistance between electric throttle relay connector and chassis ground. <i>Connector &amp; terminal</i> <i>(B309) No. 3 — Engine ground:</i> <i>(B309) No. 4 — Engine ground:</i>	Is the resistance more than 1 $M\Omega$ ?	Go to step 5.	Repair the ground short of harness between ECM and electric throttle relay.
<b>5 CHECK HARNESS BETWEEN ECM AND ELECTRIC THROTTLE RELAY.</b> 1) Turn the ignition switch to OFF. 2) Measure the resistance between electric throttle connector and electric throttle relay connector. <i>Connector &amp; terminal</i> <i>(B135) No. 35 — (B309) No. 3:</i> <i>(B137) No. 6 — (B309) No. 4:</i>	Is the resistance less than 1 $\Omega$ ?	Go to step 6.	Repair the open circuit of harness between ECM and electric throttle relay.
<b>6 CHECK OUTPUT VOLTAGE OF SENSOR.</b> 1) Connect all the connectors. 2) Turn the ignition switch to ON. 3) Measure the voltage between ECM connector terminals. <i>Connector &amp; terminal</i> <i>(B136) No. 18 (+) — (B136) No. 35 (-):</i> 4) Shake the ECM harness and connector, engine harness connectors (B136, F61), electric throttle connector harness while monitoring value of voltage meter.	Is the voltage more than 0.4 V?	Go to step 7.	Go to step 9.

# DIAGNOSTIC PROCEDURE WITH DIAGNOSTIC TROUBLE CODE (DTC)

## ENGINE (DIAGNOSTICS)

Step	Check	Yes	No
<b>7 CHECK OUTPUT VOLTAGE OF SENSOR.</b> 1)Connect all the connectors. 2)Turn the ignition switch to ON. 3)Measure the voltage between ECM connector terminals. <i><b>Connector &amp; terminal</b></i> <i><b>(B136) No. 29 (+) — (B136) No. 35 (-):</b></i> 4)Shake the ECM harness and connector, engine harness connectors, electric throttle connector harness while monitoring value of voltage meter.	Is the voltage more than 0.8 V?	Go to step 8.	Go to step 9.
<b>8 CHECK POOR CONTACT.</b> Check poor contact between ECM connector and electric throttle connector.	Is there poor contact between ECM connector and electric throttle connector?	Repair the poor contact.	Go to step 13.
<b>9 CHECK HARNESS BETWEEN ECM AND ELECTRIC THROTTLE.</b> 1)Turn the ignition switch to OFF. 2)Disconnect the connector from ECM. 3)Disconnect the connector from electric throttle. 4)Measure the resistance between ECM connector and electric throttle connector. <i><b>Connector &amp; terminal</b></i> <i><b>(B136) No. 16 — (E57) No. 5:</b></i>	Is the resistance less than 1 $\Omega$ ?	Go to step 10.	Repair the open harness connector.
<b>10 CHECK THE HARNESS BETWEEN ECM AND ELECTRIC THROTTLE.</b> Measure the resistance between ECM connector and chassis ground. <i><b>Connector &amp; terminal</b></i> <i><b>(B136) No. 16 — Chassis ground:</b></i> <i><b>(B136) No. 18 — Chassis ground:</b></i> <i><b>(B136) No. 29 — Chassis ground:</b></i>	Is the resistance more than 1 M $\Omega$ ?	Go to step 11.	Repair the ground short of harness.
<b>11 CHECK POWER SUPPLY TO SENSOR.</b> 1)Connect the ECM connector. 2)Turn the ignition switch to ON. 3)Measure the resistance between electric throttle connector and engine ground. <i><b>Connector &amp; terminal</b></i> <i><b>(E57) No.5 (+) — Engine ground (-):</b></i> 4)Shake the ECM harness and connector, engine harness connectors, while monitoring value of voltage meter.	Is the voltage 4.5 — 5.5 V?	Go to step 12.	Repair the poor contact in ECM connector. If problem persists, replace the ECM. <Ref. to FU(STi)-41, Engine Control Module (ECM).>
<b>12 CHECK SHORT OF ECM.</b> 1)Turn the ignition switch to OFF. 2)Measure the resistance between electric throttle connector and engine ground. <i><b>Connector &amp; terminal</b></i> <i><b>(E57) No. 6 — Engine ground:</b></i> <i><b>(E57) No. 4 — Engine ground:</b></i>	Is the resistance more than 10 $\Omega$ ?	Go to step 13.	Repair the poor contact in ECM connector. If problem persists, replace the ECM.
<b>13 CHECK OUTPUT VOLTAGE OF SENSOR.</b> 1)Connect all the connectors. 2)Turn the ignition switch to ON. 3)Read the data of main throttle sensor signal, using the Subaru Select Monitor. 4)Shake the ECM harness and connector, engine harness connectors, electric throttle connector harness while monitoring value of voltage meter.	Is the voltage 4.63 V?	Go to step 14.	Go to step 16.



# DIAGNOSTIC PROCEDURE WITH DIAGNOSTIC TROUBLE CODE (DTC)

ENGINE (DIAGNOSTICS)

Step	Check	Yes	No
<b>14 CHECK OUTPUT VOLTAGE OF SENSOR.</b> 1)Read the data of sub throttle sensor signal, using the Subaru Select Monitor. 2)Shake the ECM harness and connector, engine harness connectors, electric throttle connector harness while monitoring value of voltage meter.	Is the voltage 4.73 V?	Go to step 15.	Go to step 16.
<b>15 CHECK POOR CONTACT IN CONNECTORS.</b> Check poor contact in connectors between ECM and electric throttle?	Is there poor contact in connectors between ECM and electric throttle?	Repair the poor contact in connectors.	Go to step 21.
<b>16 CHECK HARNESS BETWEEN ECM AND ELECTRIC THROTTLE.</b> 1)Turn the ignition switch to OFF. 2)Disconnect the connector from ECM. 3)Disconnect the connector from electric throttle. 4)Measure the resistance between ECM connector and electric throttle connector. <b>Connector &amp; terminal</b> <b>(B136) No. 35 — (E57) No. 3:</b> <b>(B136) No. 18 — (E57) No. 6:</b> <b>(B136) No. 29 — (E57) No. 4:</b>	Is the resistance less than 1 $\Omega$ ?	Go to step 17.	Repair the open harness connector.
<b>17 CHECK HARNESS BETWEEN ECM AND ELECTRIC THROTTLE.</b> 1)Connect the ECM connector. 2)Measure the resistance between electric throttle connector and engine ground. <b>Connector &amp; terminal</b> <b>(E57) No. 3 — Engine ground:</b>	Is the resistance less than 5 $\Omega$ ?	Go to step 18.	Repair the poor contact in ECM connector. If problem persists, replace the ECM.
<b>18 CHECK HARNESS BETWEEN ECM AND ELECTRIC THROTTLE.</b> 1)Turn the ignition switch to ON. 2)Measure the voltage between electric throttle connector and engine ground. <b>Connector &amp; terminal</b> <b>(E57) No. 5 (+) — Engine ground (-):</b> 3)Shake the ECM harness and connector, engine harness connectors, while monitoring value of voltage meter.	Is the voltage more than 10 V?	Go to step 19.	Repair the battery short of harness between ECM connector and electric throttle connector.
<b>19 CHECK HARNESS BETWEEN ECM AND ELECTRIC THROTTLE.</b> 1)Measure the voltage between electric throttle connector and engine ground. <b>Connector &amp; terminal</b> <b>(E57) No. 6 (+) — Engine ground (-):</b> <b>(E57) No. 4 (+) — Engine ground (-):</b> 2)Shake the ECM harness and connector, engine harness connectors, while monitoring value of voltage meter.	Is the voltage less than 10 V?	Go to step 20.	Repair the short of harness between ECM connector and electric throttle connector.
<b>20 CHECK HARNESS BETWEEN ECM AND ELECTRIC THROTTLE.</b> 1)Turn the ignition switch to OFF. 2)Remove the ECM. 3)Measure the voltage between ECM connectors. <b>Connector &amp; terminal</b> <b>(B136) No. 18 — (B136) No. 35:</b> <b>(B136) No. 29 — (B136) No. 35:</b>	Is the resistance more than 1 M $\Omega$ ?	Go to step 21.	Repair the short of sensor power supply.

# DIAGNOSTIC PROCEDURE WITH DIAGNOSTIC TROUBLE CODE (DTC)

## ENGINE (DIAGNOSTICS)

Step	Check	Yes	No
<b>21 CHECK OUTPUT VOLTAGE OF SENSOR.</b> 1) Turn the ignition switch to OFF. 2) Connect all the connectors except electric throttle replay. 3) Turn the ignition switch to ON. 4) Read the data of main throttle sensor signals, using Subaru Select Monitor.	Is the voltage 0.81 — 0.87 V?	Go to step 22.	Repair the poor contact in electric throttle connector. If problem persists, replace the electric throttle.
<b>22 CHECK OUTPUT VOLTAGE OF SENSOR.</b> Read the data of sub throttle sensor signals, using Subaru Select Monitor.	Is the voltage 1.64 — 1.70 V?	Go to step 23.	Repair the poor contact in electric throttle connector. If problem persists, replace the electric throttle.
<b>23 CHECK HARNESS BETWEEN ECM AND ELECTRIC THROTTLE MOTOR.</b> 1) Turn the ignition switch to OFF. 2) Disconnect the connector from ECM. 3) Disconnect the connectors from electric throttle. 4) Measure the resistance between ECM connector and electric throttle connector.  <i>Connector &amp; terminal</i> <i>(B137) No. 5 — (E57) No. 2:</i> <i>(B137) No. 4 — (E57) No. 1:</i>	Is the resistance less than 1 $\Omega$ ?	Go to step 24.	Repair the open harness connector.
<b>24 CHECK HARNESS BETWEEN ECM AND ELECTRIC THROTTLE MOTOR.</b> 1) Connect the connectors to ECM. 2) Turn the ignition switch to ON. 3) Measure the voltage between electric throttle connector and engine ground.  <i>Connector &amp; terminal</i> <i>(E57) No. 2 (+) — Engine ground (-):</i> <i>(E57) No. 1 (+) — Engine ground (-):</i>	Is the voltage less than 5 V?	Go to step 25.	Repair the short of harness to power supply circuit between ECM and electric throttle.
<b>25 CHECK HARNESS BETWEEN ECM AND ELECTRIC THROTTLE MOTOR.</b> 1) Turn the ignition switch to OFF. 2) Disconnect the connector from ECM. 3) Measure the resistance between electric throttle connector and engine ground.  <i>Connector &amp; terminal</i> <i>(E57) No. 2 — Engine ground:</i> <i>(E57) No. 1 — Engine ground:</i>	Is the resistance more than 1 $M\Omega$ ?	Go to step 26.	Repair the short of harness.
<b>26 CHECK ELECTRIC THROTTLE MOTOR HARNESS.</b> Measure the resistance between electric throttle connector terminals.  <i>Connector &amp; terminal</i> <i>(E57) No. 2 — (E57) No. 1:</i>	Is the resistance more than 1 $M\Omega$ ?	Go to step 27.	Repair the short of harness.
<b>27 CHECK ELECTRIC THROTTLE GROUND CIRCUIT.</b> Measure the resistance between ECM connector and engine ground.  <i>Connector &amp; terminal</i> <i>(B137) No. 3 — Engine ground:</i>	Is the resistance less than 10 $\Omega$ ?	Go to step 28.	Repair the open circuit harness.
<b>28 CHECK ELECTRIC THROTTLE.</b> Measure the resistance between electric throttle terminals.  <i>Terminals</i> <i>No. 1 — No. 2:</i>	Is the resistance less than 5 $\Omega$ ?	Go to step 29.	Replace the electric throttle.

# DIAGNOSTIC PROCEDURE WITH DIAGNOSTIC TROUBLE CODE (DTC)

ENGINE (DIAGNOSTICS)

Step	Check	Yes	No
<b>29</b> <b>CHECK ELECTRIC THROTTLE.</b> Open and close the throttle valve to its full width with finger.	Does it return to specified position (3 mm (0.12 in) open from fully closed position.) when finger is released?	Repair the poor contact in ECM connector. If problem persists, replace the ECM. <Ref. to FU(STi)-41, Engine Control Module (ECM).>	Replace the electric throttle.

## DIAGNOSTIC PROCEDURE WITH DIAGNOSTIC TROUBLE CODE (DTC)

ENGINE (DIAGNOSTICS)

---

### DK:DTC P2102 — THROTTLE ACTUATOR CONTROL MOTOR CIRCUIT LOW —

- **DTC DETECTING CONDITION:**

- Immediately at fault recognition
- GENERAL DESCRIPTION <Ref. to GD(STi)-254, DTC P2102 — THROTTLE ACTUATOR CONTROL MOTOR CIRCUIT LOW —, Diagnostic Trouble Code (DTC) Detecting Criteria.>

- **TROUBLE SYMPTOM:**

- Erroneous idling
- Poor driving performance
- Engine stalls.

# DIAGNOSTIC PROCEDURE WITH DIAGNOSTIC TROUBLE CODE (DTC)

ENGINE (DIAGNOSTICS)

• WIRING DIAGRAM:

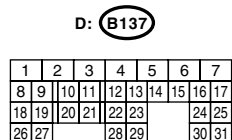
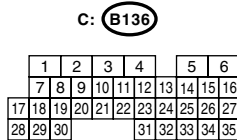
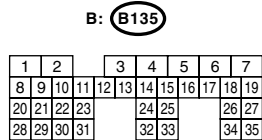
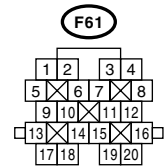
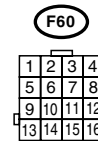
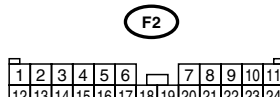
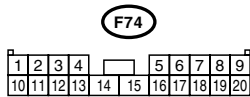
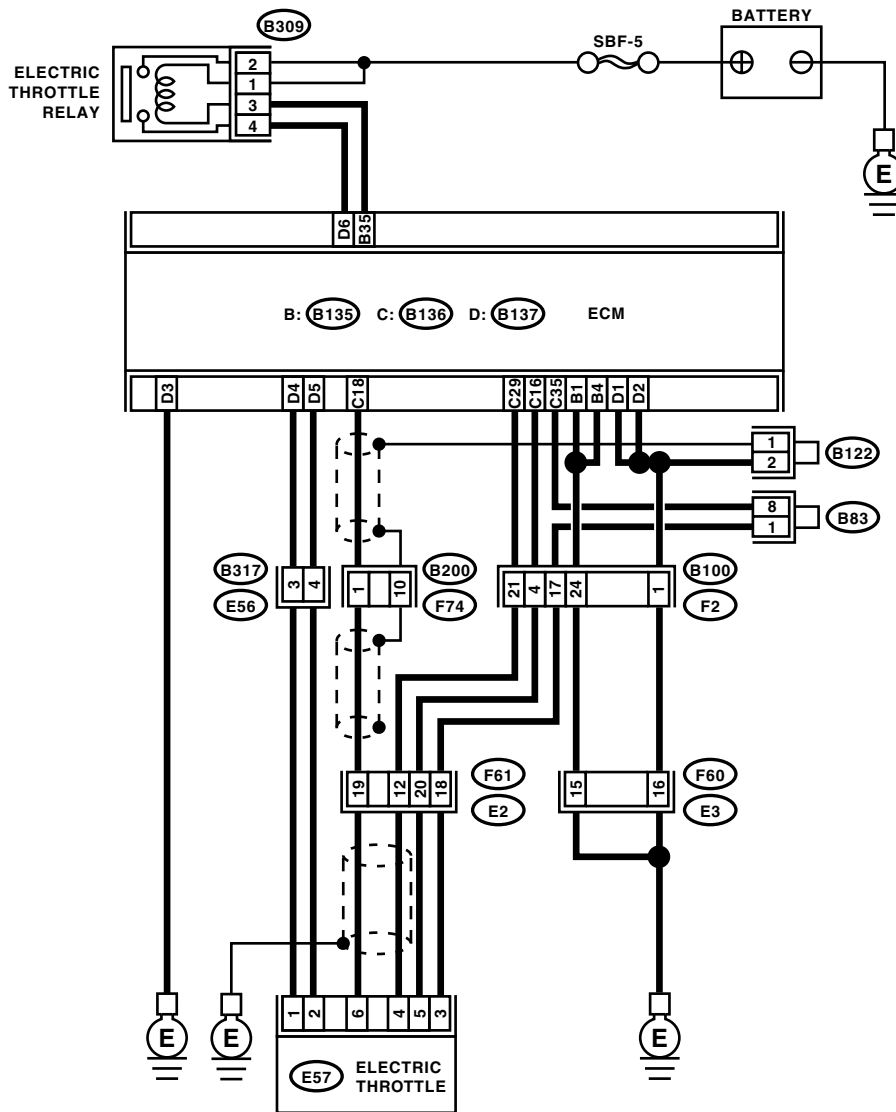

EN-01825

# DIAGNOSTIC PROCEDURE WITH DIAGNOSTIC TROUBLE CODE (DTC)

## ENGINE (DIAGNOSTICS)

Step	Check	Yes	No
<b>1 CHECK ELECTRIC THROTTLE RELAY.</b> 1) Turn the ignition switch to OFF. 2) Remove the electric throttle relay. 3) Connect the battery to electric throttle relay terminal No. 1 and No. 3. 4) Measure the resistance between electric throttle terminals. <i>Connector &amp; terminal</i> <i>(B309) No. 2 — (B309) No. 4:</i>	Is the resistance less than 1 $\Omega$ ?	Go to step 2.	Replace the electric throttle relay.
<b>2 CHECK POWER TO ELECTRIC THROTTLE RELAY</b> Measure the voltage between electric throttle relay connector and engine ground. <i>Connector &amp; terminal</i> <i>(B309) No. 1 (+) — Engine ground (-):</i> <i>(B309) No. 2 (+) — Engine ground (-):</i>	Is the voltage more than 5 V?	Go to step 3.	Repair the open power supply circuit or ground short.
<b>3 CHECK HARNESS BETWEEN ECM AND ELECTRIC THROTTLE.</b> 1) Disconnect the connector from ECM. 2) Turn the ignition switch to ON. 3) Measure the voltage between electric throttle relay connector and engine ground. <i>Connector &amp; terminal</i> <i>(B309) No. 3 (+) — Engine ground (-):</i>	Is the voltage less than 5 V?	Go to step 4.	Repair the short of power supply circuit between ECM and electric throttle.
<b>4 CHECK HARNESS BETWEEN ECM AND ELECTRIC THROTTLE RELAY.</b> 1) Turn the ignition switch to OFF. 2) Measure the resistance between electric throttle relay connector and chassis ground. <i>Connector &amp; terminal</i> <i>(B309) No. 3 — Engine ground:</i> <i>(B309) No. 4 — Engine ground:</i>	Is the resistance more than 1 M $\Omega$ ?	Go to step 5.	Repair the ground short of harness between ECM and electric throttle relay.
<b>5 CHECK HARNESS BETWEEN ECM AND ELECTRIC THROTTLE RELAY.</b> Measure the resistance between ECM connector and electric throttle relay connector. <i>Connector &amp; terminal</i> <i>(B135) No. 35 — (B309) No. 3:</i> <i>(B137) No. 6 — (B309) No. 4:</i>	Is the resistance less than 1 $\Omega$ ?	Repair the poor contact in ECM connector. If problem persists, replace the ECM.	Repair the open harness between ECM and electric throttle relay.

# DIAGNOSTIC PROCEDURE WITH DIAGNOSTIC TROUBLE CODE (DTC)

ENGINE (DIAGNOSTICS)

## DL:DTC P2103 — THROTTLE ACTUATOR CONTROL MOTOR CIRCUIT HIGH —

### • DTC DETECTING CONDITION:

- Immediately at fault recognition
- GENERAL DESCRIPTION <Ref. to GD(STi)-256, DTC P2103 — THROTTLE ACTUATOR CONTROL MOTOR CIRCUIT HIGH —, Diagnostic Trouble Code (DTC) Detecting Criteria.>

### • WIRING DIAGRAM:

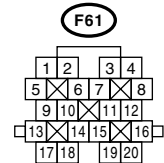
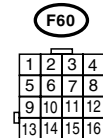
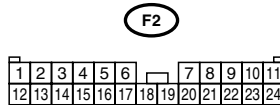
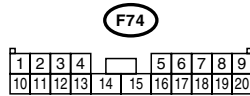
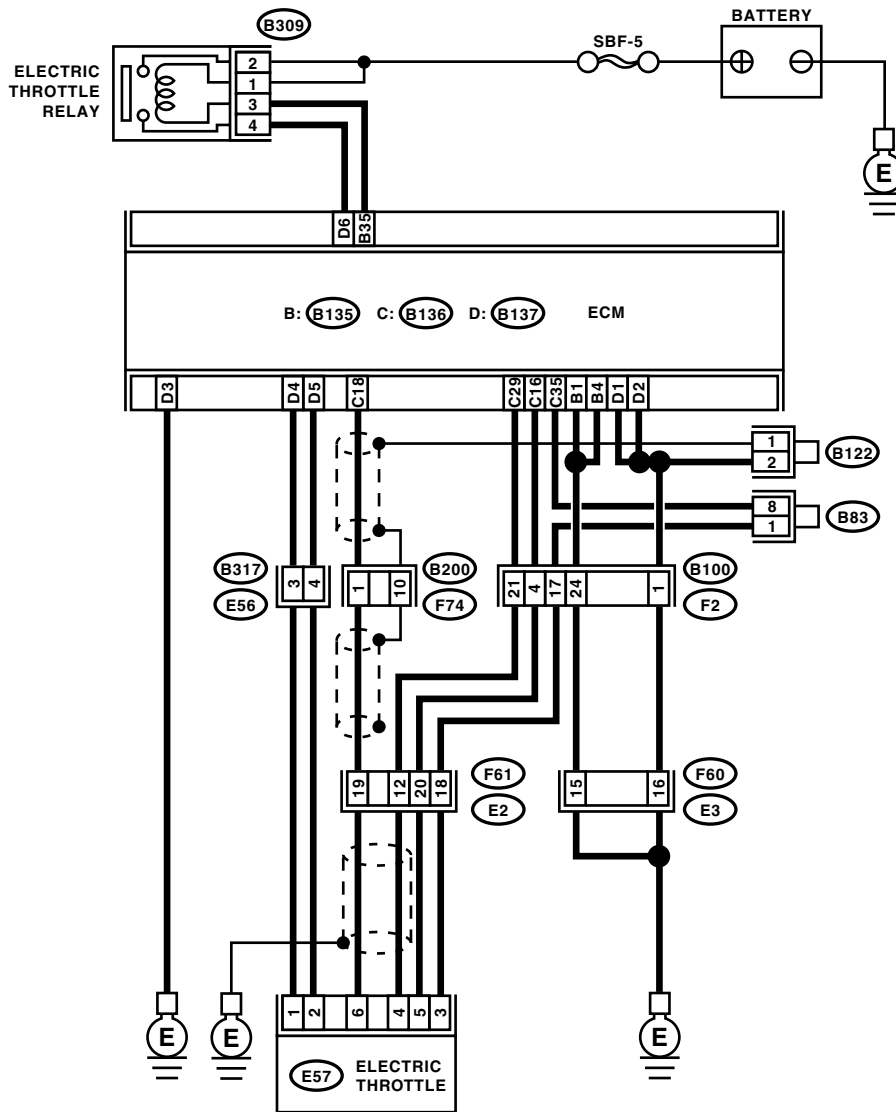

B: B135

C: B136

D: B137

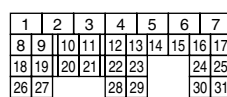
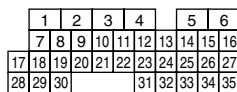
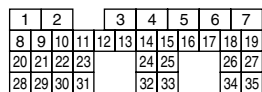
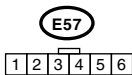

EN-01825

# DIAGNOSTIC PROCEDURE WITH DIAGNOSTIC TROUBLE CODE (DTC)

ENGINE (DIAGNOSTICS)

Step	Check	Yes	No
<b>1 CHECK ELECTRIC THROTTLE RELAY.</b> 1) Turn the ignition switch to OFF. 2) Remove the electric throttle relay. 3) Measure the resistance between electric throttle relay terminals. <i>Terminals</i> <i>No. 2 — No. 4:</i>	Is the resistance more than 1 M $\Omega$ ?	Go to step 2.	Replace the electric throttle relay.
<b>2 CHECK SHORT OF ELECTRIC THROTTLE RELAY POWER SUPPLY CIRCUIT.</b> 1) Turn the ignition switch to ON. 2) Measure the voltage between electric throttle relay connector and engine ground. <i>Connector &amp; terminal</i> <i>(B309) No. 4 (+) — Engine ground (-):</i>	Is the voltage more than 5 V?	Go to step 3.	Repair the short of power supply to harness between ECM and electric throttle relay.
<b>3 CHECK HARNESS BETWEEN ECM AND ELECTRIC THROTTLE RELAY.</b> 1) Turn the ignition switch to OFF. 2) Disconnect the connectors from ECM. 3) Measure the resistance between ECM connector and engine ground. <i>Connector &amp; terminal</i> <i>(B135) No. 35 — Engine ground:</i>	Is the resistance more than 1 M $\Omega$ ?	Repair the poor contact in ECM connector. If problem persists, replace the ECM.	Repair the ground short of harness between ECM and electric throttle relay.

## DM:DTC P2109 — THROTTLE/PEDAL POSITION SENSOR A MINIMUM STOP PERFORMANCE —

NOTE:

For the diagnostic procedure, refer to DTC P2101. <Ref. to EN(STi)-325, DTC P2101 — THROTTLE ACTUATOR CONTROL MOTOR CIRCUIT RANGE/PERFORMANCE —, Diagnostic Procedure with Diagnostic Trouble Code (DTC).>



# DIAGNOSTIC PROCEDURE WITH DIAGNOSTIC TROUBLE CODE (DTC) ENGINE (DIAGNOSTICS)

## DN:DTC P2122 — THROTTLE/PEDAL POSITION SENSOR/SWITCH “D” CIRCUIT LOW INPUT —

- **DTC DETECTING CONDITION:**
  - Immediately at fault recognition
  - GENERAL DESCRIPTION <Ref. to GD(STi)-260, DTC P2122 — THROTTLE/PEDAL POSITION SENSOR/SWITCH “D” CIRCUIT LOW INPUT —, Diagnostic Trouble Code (DTC) Detecting Criteria.>
- **TROUBLE SYMPTOM:**
  - Erroneous idling
  - Poor driving performance
- **WIRING DIAGRAM:**

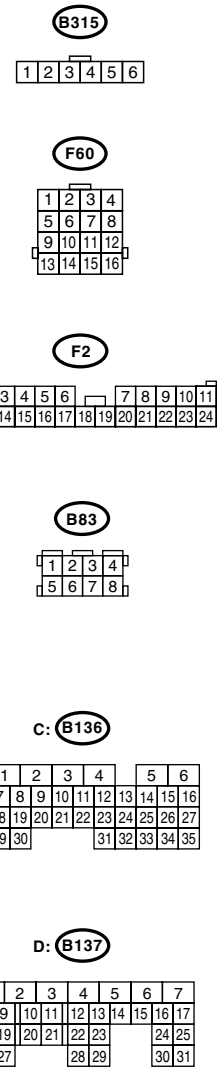
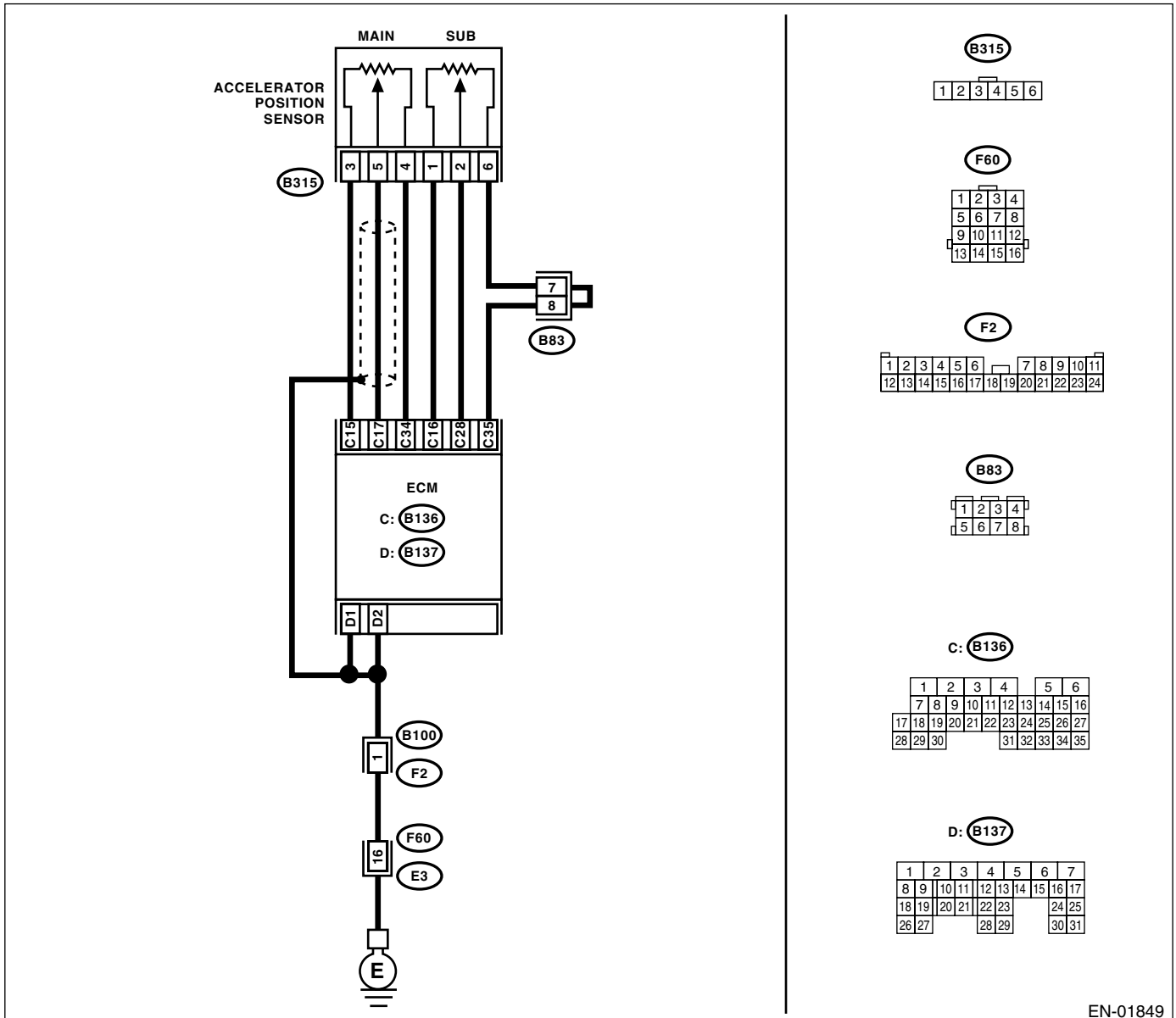

EN-01849

# DIAGNOSTIC PROCEDURE WITH DIAGNOSTIC TROUBLE CODE (DTC)

ENGINE (DIAGNOSTICS)

Step	Check	Yes	No
<p><b>1 CHECK OUTPUT VOLTAGE OF ACCELERATOR POSITION SENSOR.</b>                      1) Turn the ignition switch to ON.                      2) Measure the voltage between ECM connector terminals.  <i>Connector &amp; terminal</i>  <i>(B136) No. 17 (+) — (B136) No. 34 (-):</i>                      3) Shake the ECM harness and connector, accelerator position sensor.</p>	Is the voltage more than 0.4 V?	Go to step 2.	Go to step 3.
<p><b>2 CHECK POOR CONTACT IN CONNECTORS.</b>                      Check poor contact in connectors between ECM and accelerator position sensor.</p>	Is there poor contact in connectors between ECM and accelerator position sensor?	Repair the poor contact in connectors.	Connector has returned to its normal condition at this time. A temporary poor contact of the connector may be the cause.
<p><b>3 CHECK HARNESS BETWEEN ECM AND ACCELERATOR POSITION SENSOR.</b>                      1) Turn the ignition switch to OFF.                      2) Disconnect the connector from ECM.                      3) Disconnect the connector from accelerator position sensor.                      4) Measure the resistance between ECM connector and accelerator position sensor.  <i>Connector &amp; terminal</i>  <i>(B136) No. 17 — (B315) No. 5:</i>  <i>(B136) No. 15 — (B315) No. 3:</i></p>	Is the resistance less than 1 $\Omega$ ?	Go to step 4.	Repair the open harness connector.
<p><b>4 CHECK HARNESS BETWEEN ECM AND ACCELERATOR POSITION SENSOR.</b>                      Measure the resistance between ECM connector and chassis ground.  <i>Connector &amp; terminal</i>  <i>(B136) No. 17 — Chassis ground:</i>  <i>(B136) No. 15 — Chassis ground:</i></p>	Is the resistance more than 1 M $\Omega$ ?	Go to step 5.	Repair the open harness connector.
<p><b>5 CHECK ACCELERATOR POSITION SENSOR POWER SUPPLY</b>                      1) Connect the ECM connector.                      2) Turn the ignition switch to ON.                      3) Measure the voltage between accelerator position sensor connector and engine ground.  <i>Connector &amp; terminal</i>  <i>(B315) No. 3 (+) — Engine ground (-):</i>                      4) Shake the ECM harness and connector, while monitoring value of voltage meter.</p>	Is the voltage 4.5 — 5.5 V?	Go to step 6.	Repair the poor contact in ECM connector. If problem persists, replace the ECM. <Ref. to FU(STi)-41, Engine Control Module (ECM).>
<p><b>6 CHECK ACCELERATOR POSITION SENSOR.</b>                      Measure the resistance of accelerator position sensor.  <i>Terminals</i>  <i>No. 3 — No. 4:</i></p>	Is the resistance 1.2 — 4.8 k $\Omega$ ?	Go to step 7.	Replace the accelerator position sensor.
<p><b>7 CHECK ACCELERATOR POSITION SENSOR.</b>                      Measure the resistance of accelerator position sensor when accelerator pedal is released.  <i>Terminals</i>  <i>No. 5 — No. 4:</i></p>	Is the resistance 0.2 — 1.0 k $\Omega$ ?	Go to step 8.	Replace the accelerator position sensor.

# DIAGNOSTIC PROCEDURE WITH DIAGNOSTIC TROUBLE CODE (DTC)

ENGINE (DIAGNOSTICS)

Step	Check	Yes	No
<b>8</b> <b>CHECK ACCELERATOR POSITION SENSOR.</b> Measure the resistance of accelerator position sensor when acceleration pedal is being depressed. <b>Terminals</b> <b>No. 5 — No. 4:</b>	Is the resistance 0.5 — 2.5 k $\Omega$ ?	Repair the poor contact in ECM connector. If problem persists, replace the ECM.	Replace the accelerator position sensor.

# DIAGNOSTIC PROCEDURE WITH DIAGNOSTIC TROUBLE CODE (DTC)

ENGINE (DIAGNOSTICS)

## DO:DTC P2123 — THROTTLE/PEDAL POSITION SENSOR/SWITCH “D” CIRCUIT HIGH INPUT —

### • DTC DETECTING CONDITION:

- Immediately at fault recognition
- GENERAL DESCRIPTION <Ref. to GD(STi)-262, DTC P2123 — THROTTLE/PEDAL POSITION SENSOR/SWITCH “D” CIRCUIT HIGH INPUT —, Diagnostic Trouble Code (DTC) Detecting Criteria.>

### • TROUBLE SYMPTOM:

- Erroneous idling
- Poor driving performance

### • WIRING DIAGRAM:

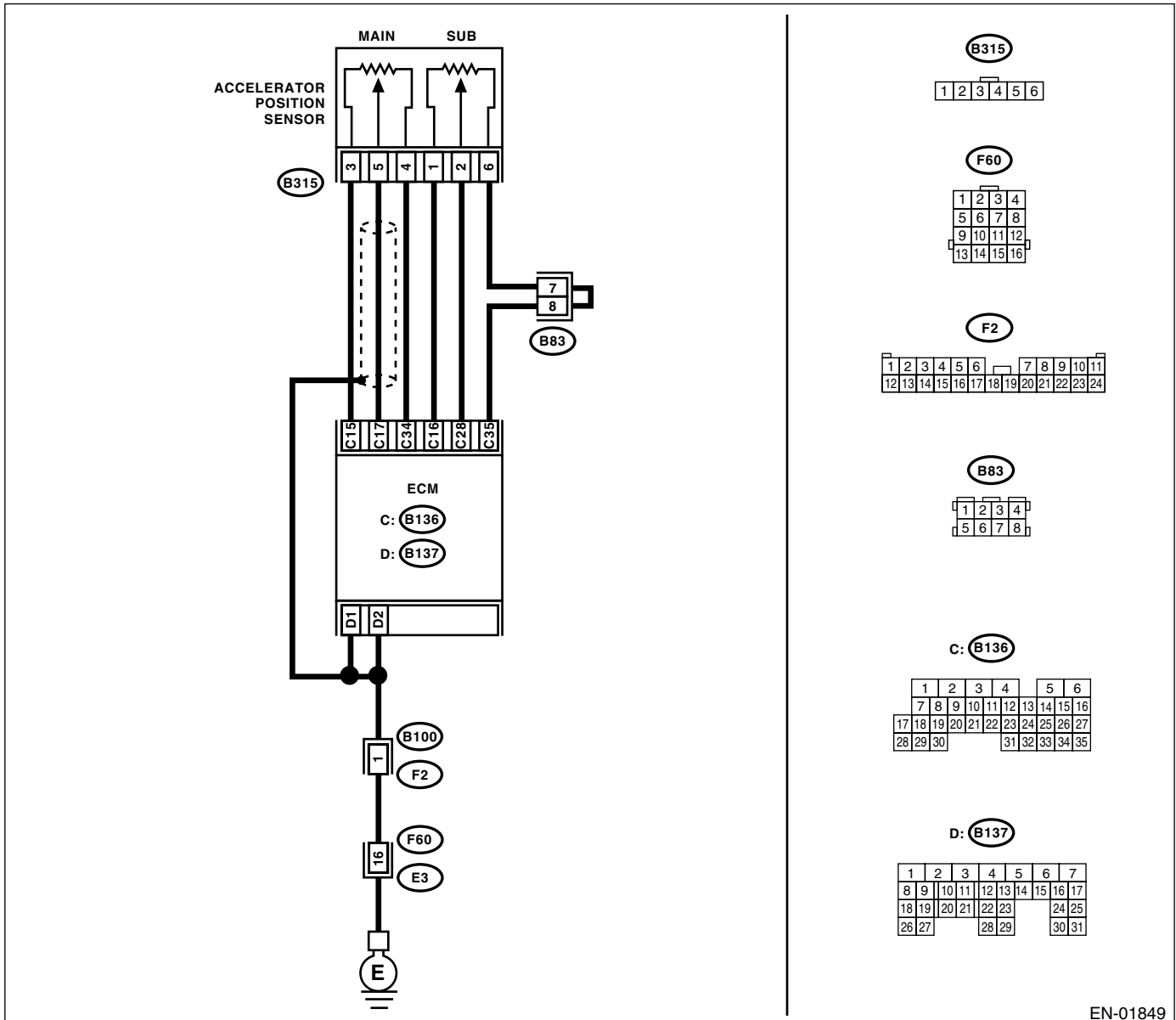

EN-01849

# DIAGNOSTIC PROCEDURE WITH DIAGNOSTIC TROUBLE CODE (DTC)

ENGINE (DIAGNOSTICS)

Step	Check	Yes	No
<b>1 CHECK OUTPUT VOLTAGE OF ACCELERATOR POSITION SENSOR.</b> 1) Turn the ignition switch to ON. 2) Read the data of main accelerator position sensor signals, using Subaru Select Monitor. 3) Shake the ECM harness and connector, engine harness connector, accelerator position sensor connector harness while monitoring value of voltage meter.	Is the voltage less than 4.8 V?	Go to step 2.	Go to step 3.
<b>2 CHECK POOR CONTACT IN CONNECTORS.</b> Check poor contact in connectors between ECM and accelerator position sensor.	Is there any poor contact in connectors between ECM and accelerator position sensor?	Repair the poor contact in connectors.	Connector has returned to its normal condition at this time. A temporary poor contact in the connector might have been the cause.
<b>3 CHECK HARNESS BETWEEN ECM AND ACCELERATOR POSITION SENSOR.</b> 1) Turn the ignition switch to OFF. 2) Disconnect the connector from ECM. 3) Disconnect the connector from accelerator position sensor. 4) Measure the resistance between ECM connector and accelerator position sensor. <i>Connector &amp; terminal</i> <i>(B136) No. 34 — (B315) No. 4:</i>	Is the resistance less than 1 $\Omega$ ?	Go to step 4.	Repair the open harness connector.
<b>4 CHECK HARNESS BETWEEN ECM AND ACCELERATOR POSITION SENSOR.</b> 1) Connect the ECM connector. 2) Measure the resistance between accelerator position sensor and engine ground. <i>Connector &amp; terminal</i> <i>(B315) No. 4 — Engine ground:</i>	Is the resistance less than 5 $\Omega$ ?	Go to step 5.	Repair the poor contact in ECM connector. If problem persists, replace the ECM. <Ref. to FU(STi)-41, Engine Control Module (ECM).>
<b>5 CHECK HARNESS BETWEEN ECM AND ACCELERATOR POSITION SENSOR.</b> 1) Connect the ECM connector. 2) Turn the ignition switch to ON. 3) Measure the voltage between accelerator position sensor connector and engine ground. <i>Connector &amp; terminal</i> <i>(B315) No. 3 (+) — Engine ground (-):</i> 4) Shake the ECM harness and connector, while monitoring value of voltage meter.	Is the voltage more than 6 V?	Go to step 6.	Repair the battery short of harness between ECM connector and accelerator position sensor.
<b>6 CHECK POWER SUPPLY TO ACCELERATOR POSITION SENSOR.</b> 1) Measure the voltage between accelerator position sensor connector and engine ground. <i>Connector &amp; terminal</i> <i>(B315) No. 5 (+) — Engine ground (-):</i> 2) Shake the ECM harness and connector, while monitoring value of voltage meter.	Is the voltage less than 4.8 V?	Go to step 7.	Repair the short of harness between ECM connector and accelerator position sensor connector.

# DIAGNOSTIC PROCEDURE WITH DIAGNOSTIC TROUBLE CODE (DTC)

ENGINE (DIAGNOSTICS)

Step	Check	Yes	No
<p>7</p> <p><b>CHECK HARNESS BETWEEN ECM AND ACCELERATOR POSITION SENSOR.</b></p> <p>1) Turn the ignition switch to OFF.</p> <p>2) Connect the accelerator position sensor connector.</p> <p>3) Turn the ignition switch to ON.</p> <p>4) Measure the voltage between ECM connector and chassis ground.</p> <p><b>Connector &amp; terminal</b> <b>(B136) No. 17 (+) — Chassis ground (-):</b></p>	Is the voltage 4.8 V?	Repair the poor contact in ECM connector. If problem persists, replace the ECM. <Ref. to FU(STi)-41, Engine Control Module (ECM).>	Repair the poor contact in electric throttle connector. If problem persists, replace the electric throttle.

# DIAGNOSTIC PROCEDURE WITH DIAGNOSTIC TROUBLE CODE (DTC) ENGINE (DIAGNOSTICS)

## DP:DTC P2127 — THROTTLE/PEDAL POSITION SENSOR/SWITCH “E” CIRCUIT LOW INPUT —

- **DTC DETECTING CONDITION:**
  - Immediately at fault recognition
  - GENERAL DESCRIPTION <Ref. to GD(STi)-264, DTC P2127 — THROTTLE/PEDAL POSITION SENSOR/SWITCH “E” CIRCUIT LOW INPUT —, Diagnostic Trouble Code (DTC) Detecting Criteria.>
- **TROUBLE SYMPTOM:**
  - Erroneous idling
  - Poor driving performance
- **WIRING DIAGRAM:**

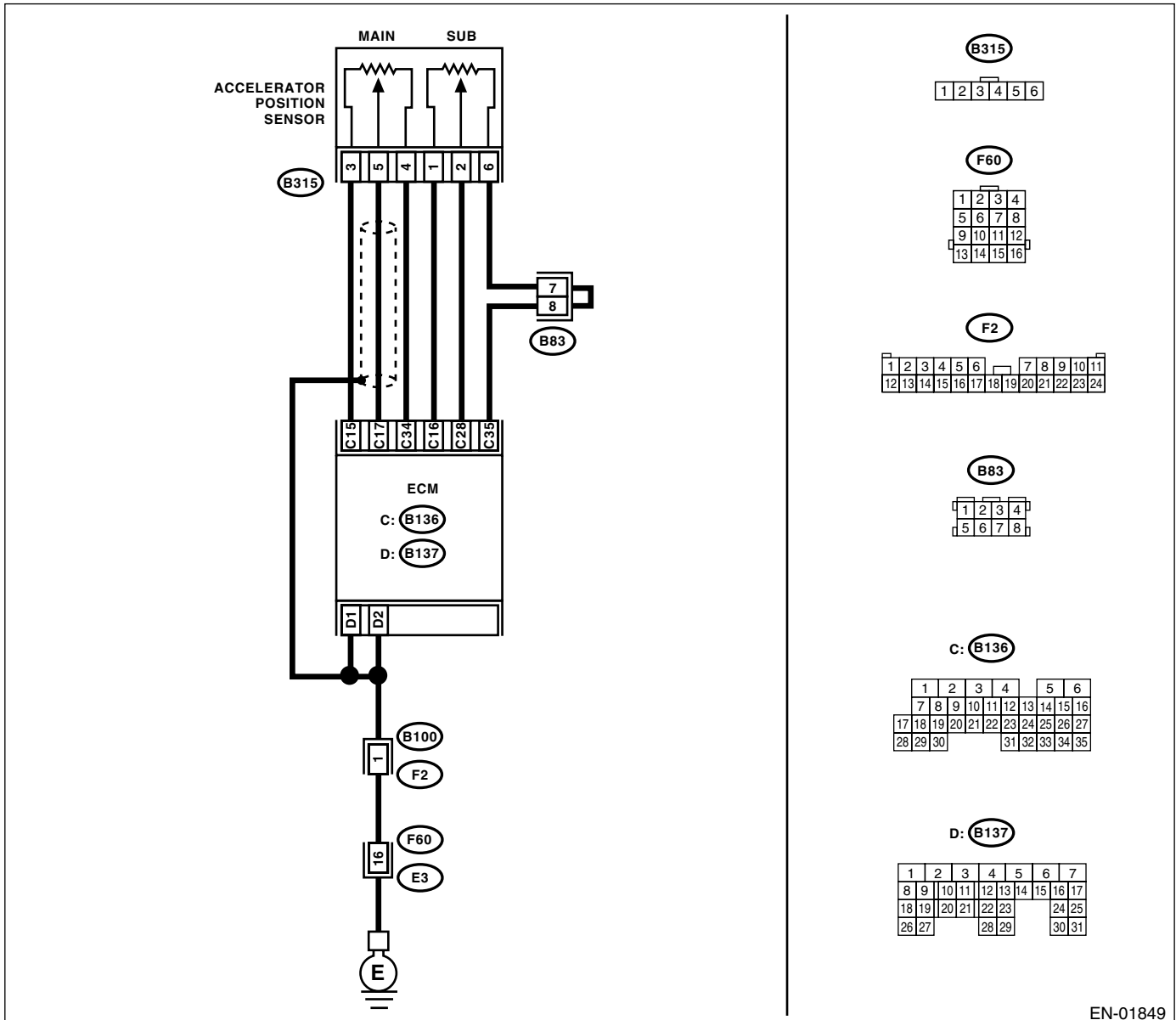

EN-01849

# DIAGNOSTIC PROCEDURE WITH DIAGNOSTIC TROUBLE CODE (DTC)

## ENGINE (DIAGNOSTICS)

Step	Check	Yes	No
<b>1 CHECK OUTPUT VOLTAGE OF ACCELERATOR POSITION SENSOR.</b> 1) Turn the ignition switch to ON. 2) Measure the voltage between ECM connector terminals. <i>Connector &amp; terminal</i> <i>(B136) No. 28 (+) — (B136) No. 35 (-):</i> 3) Shake the ECM harness and connector, accelerator position sensor.	Is the voltage more than 0.4 V?	Go to step 2.	Go to step 3.
<b>2 CHECK POOR CONTACT IN CONNECTORS.</b> Check poor contact in connectors between ECM and accelerator position sensor.	Is there any poor contact in connectors between ECM and accelerator position sensor?	Repair the poor contact in connectors.	Connector has returned to its normal condition at this time. A temporary poor contact in the connector might have been the cause.
<b>3 CHECK HARNESS BETWEEN ECM AND ACCELERATOR POSITION SENSOR.</b> 1) Turn the ignition switch to OFF. 2) Disconnect the connector from ECM. 3) Disconnect the connector from accelerator position sensor. 4) Measure the resistance between ECM connector and accelerator position sensor. <i>Connector &amp; terminal</i> <i>(B136) No. 28 — (B315) No. 2:</i> <i>(B136) No. 1 — (B315) No. 1:</i>	Is the resistance less than 1 $\Omega$ ?	Go to step 4.	Repair the open harness connector.
<b>4 CHECK HARNESS BETWEEN ECM AND ACCELERATOR POSITION SENSOR.</b> Measure the resistance between ECM connector and chassis ground. <i>Connector &amp; terminal</i> <i>(B136) No. 28 — Chassis ground:</i> <i>(B136) No. 16 — Chassis ground:</i>	Is the resistance more than 1 M $\Omega$ ?	Go to step 5.	Repair the ground short of harness.
<b>5 CHECK POWER SUPPLY TO ACCELERATOR POSITION SENSOR.</b> 1) Connect the ECM connector. 2) Turn the ignition switch to ON. 3) Measure the voltage between accelerator position sensor connector and engine ground. <i>Connector &amp; terminal</i> <i>(B315) No. 1 (+) — Engine ground (-):</i> 4) Shake the ECM harness and connector, while monitoring value of voltage meter.	Is the voltage 4.5 — 5.5 V?	Go to step 6.	Repair the poor contact in ECM connector. If problem persists, replace the ECM. <Ref. to FU(STi)-41, Engine Control Module (ECM).>
<b>6 CHECK ACCELERATOR POSITION SENSOR.</b> Measure the resistance of accelerator position sensor. <i>Terminals</i> <i>No. 1 — No. 6:</i>	Is the resistance 0.75 — 3.15 k $\Omega$ ?	Go to step 7.	Replace the accelerator position sensor.
<b>7 CHECK ACCELERATOR POSITION SENSOR.</b> Measure the resistance of accelerator position sensor when accelerator pedal is released. <i>Terminals</i> <i>No. 2 — No. 6:</i>	Is the resistance 0.15 — 0.63 k $\Omega$ ?	Go to step 8.	Replace the accelerator position sensor.



# DIAGNOSTIC PROCEDURE WITH DIAGNOSTIC TROUBLE CODE (DTC)

ENGINE (DIAGNOSTICS)

Step	Check	Yes	No
<b>8</b> <b>CHECK ACCELERATOR POSITION SENSOR.</b> Measure the resistance of accelerator position sensor when acceleration pedal is being depressed. <b>Terminals</b> <b>No. 2 — No. 6:</b>	Is the resistance 0.28 — 1.68 k $\Omega$ ?	Repair the poor contact in ECM connector. If problem persists, replace the ECM.	Replace the accelerator position sensor.

# DIAGNOSTIC PROCEDURE WITH DIAGNOSTIC TROUBLE CODE (DTC)

ENGINE (DIAGNOSTICS)

## DQ:DTC P2128 — THROTTLE/PEDAL POSITION SENSOR/SWITCH “E” CIRCUIT HIGH INPUT —

### • DTC DETECTING CONDITION:

- Immediately at fault recognition
- GENERAL DESCRIPTION <Ref. to GD(STi)-266, DTC P2128 — THROTTLE/PEDAL POSITION SENSOR/SWITCH “E” CIRCUIT HIGH INPUT —, Diagnostic Trouble Code (DTC) Detecting Criteria.>

### • TROUBLE SYMPTOM:

- Erroneous idling
- Poor driving performance

### • WIRING DIAGRAM:

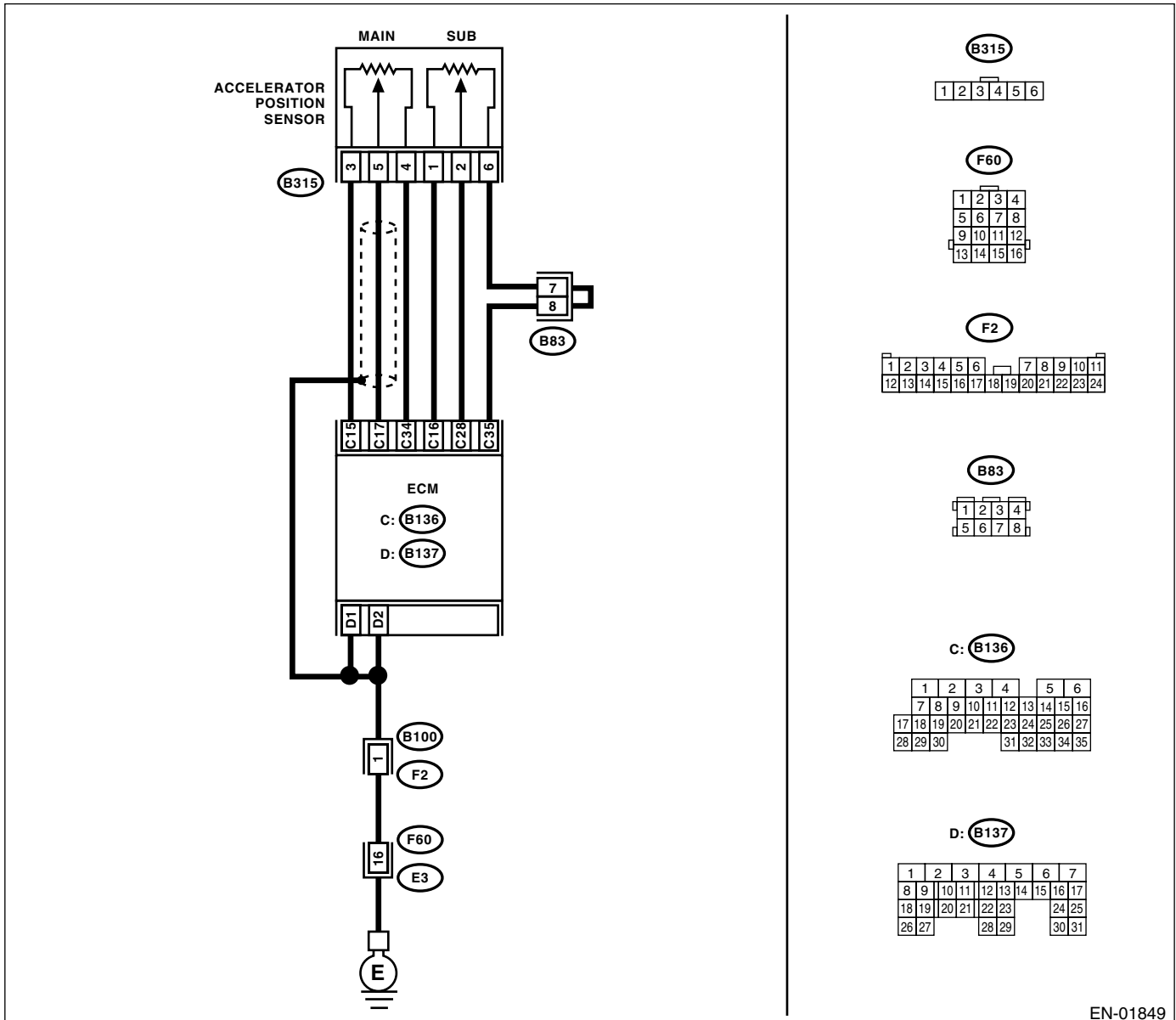

EN-01849

# DIAGNOSTIC PROCEDURE WITH DIAGNOSTIC TROUBLE CODE (DTC)

ENGINE (DIAGNOSTICS)

Step	Check	Yes	No
<b>1 CHECK OUTPUT VOLTAGE OF ACCELERATOR POSITION SENSOR.</b> 1) Turn the ignition switch to ON. 2) Read the data of sub accelerator position sensor signals, using Subaru Select Monitor. 3) Shake the ECM harness and connector, engine harness connector, accelerator position sensor connector harness while monitoring value of voltage meter.	Is the voltage less than 4.8 V?	Go to step 2.	Go to step 3.
<b>2 CHECK POOR CONTACT IN CONNECTORS.</b> Check poor contact in connectors between ECM and accelerator position sensor.	Is there any poor contact in connectors between ECM and accelerator position sensor?	Repair the poor contact in connectors.	Connector has returned to its normal condition at this time. A temporary poor contact in the connector might have been the cause.
<b>3 CHECK HARNESS BETWEEN ECM AND ACCELERATOR POSITION SENSOR.</b> 1) Turn the ignition switch to OFF. 2) Disconnect the connector from ECM. 3) Disconnect the connector from accelerator position sensor. 4) Measure the resistance between ECM connector and accelerator position sensor. <i>Connector &amp; terminal</i> <i>(B136) No. 19 — (B315) No. 6:</i>	Is the resistance less than 1 $\Omega$ ?	Go to step 4.	Repair the open harness connector.
<b>4 CHECK HARNESS BETWEEN ECM AND ACCELERATOR POSITION SENSOR.</b> 1) Connect the ECM connector. 2) Measure the resistance between accelerator position sensor connector and engine ground. <i>Connector &amp; terminal</i> <i>(B315) No. 6 — Engine ground:</i>	Is the resistance less than 5 $\Omega$ ?	Go to step 5.	Repair the poor contact in ECM connector. If problem persists, replace the ECM.
<b>5 CHECK HARNESS BETWEEN ECM AND ACCELERATOR POSITION SENSOR.</b> 1) Connect the ECM connector. 2) Turn the ignition switch to ON. 3) Measure the voltage between accelerator position sensor connector and engine ground. <i>Connector &amp; terminal</i> <i>(B315) No. 1 (+) — Engine ground (-):</i> 4) Shake the ECM harness and connector, while monitoring value of voltage meter.	Is the voltage less than 6 V?	Go to step 6.	Repair the battery short of harness between ECM connector and accelerator position sensor connector.
<b>6 CHECK POWER SUPPLY TO ACCELERATOR POSITION SENSOR.</b> 1) Measure the voltage between accelerator position sensor connector and engine ground. <i>Connector &amp; terminal</i> <i>(B315) No. 2 (+) — Engine ground (-):</i> 2) Shake the ECM harness and connector, while monitoring value of voltage meter.	Is the voltage less than 4.8 V?	Go to step 7.	Repair the short of harness between ECM connector and accelerator position sensor connector.

# DIAGNOSTIC PROCEDURE WITH DIAGNOSTIC TROUBLE CODE (DTC)

ENGINE (DIAGNOSTICS)

Step	Check	Yes	No
<p>7</p> <p><b>CHECK HARNESS BETWEEN ECM AND ACCELERATOR POSITION SENSOR.</b></p> <p>1) Turn the ignition switch to OFF.</p> <p>2) Connect the accelerator position sensor connector.</p> <p>3) Turn the ignition switch to ON.</p> <p>4) Measure the voltage between ECM connector and chassis ground.</p> <p><b>Connector &amp; terminal</b> <b>(B136) No. 16 (+) — Chassis ground (-):</b></p>	<p>Is the voltage 4.8 V?</p>	<p>Repair the poor contact in ECM connector. If problem persists, replace the ECM. &lt;Ref. to FU(STi)-41, Engine Control Module (ECM).&gt;</p>	<p>Repair the poor contact in electric throttle connector. If problem persists, replace the electric throttle.</p>

## DIAGNOSTIC PROCEDURE WITH DIAGNOSTIC TROUBLE CODE (DTC)

ENGINE (DIAGNOSTICS)

### DR:DTC P2135 — THROTTLE/PEDAL POSITION SENSOR/SWITCH “A”/“B” VOLTAGE RATIONALITY —

• **DTC DETECTING CONDITION:**

- Immediately at fault recognition
- GENERAL DESCRIPTION <Ref. to GD(STi)-268, DTC P2135 — THROTTLE/PEDAL POSITION SENSOR/SWITCH “A” / “B” VOLTAGE RATIONALITY —, Diagnostic Trouble Code (DTC) Detecting Criteria.>

• **TROUBLE SYMPTOM:**

- Erroneous idling
- Poor driving performance

**CAUTION:**

After repair or replacement of faulty parts, conduct Clear Memory Mode <Ref. to EN(STi)-42, OPERATION, Clear Memory Mode.> and Inspection Mode <Ref. to EN(STi)-35, OPERATION, Inspection Mode.>.

# DIAGNOSTIC PROCEDURE WITH DIAGNOSTIC TROUBLE CODE (DTC)

## ENGINE (DIAGNOSTICS)

### • WIRING DIAGRAM:

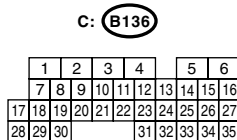
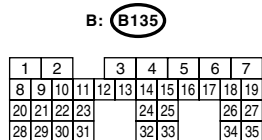
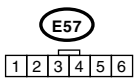
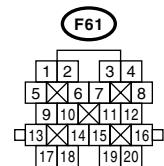
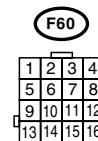
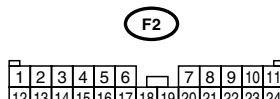
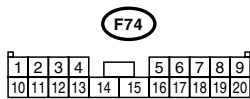
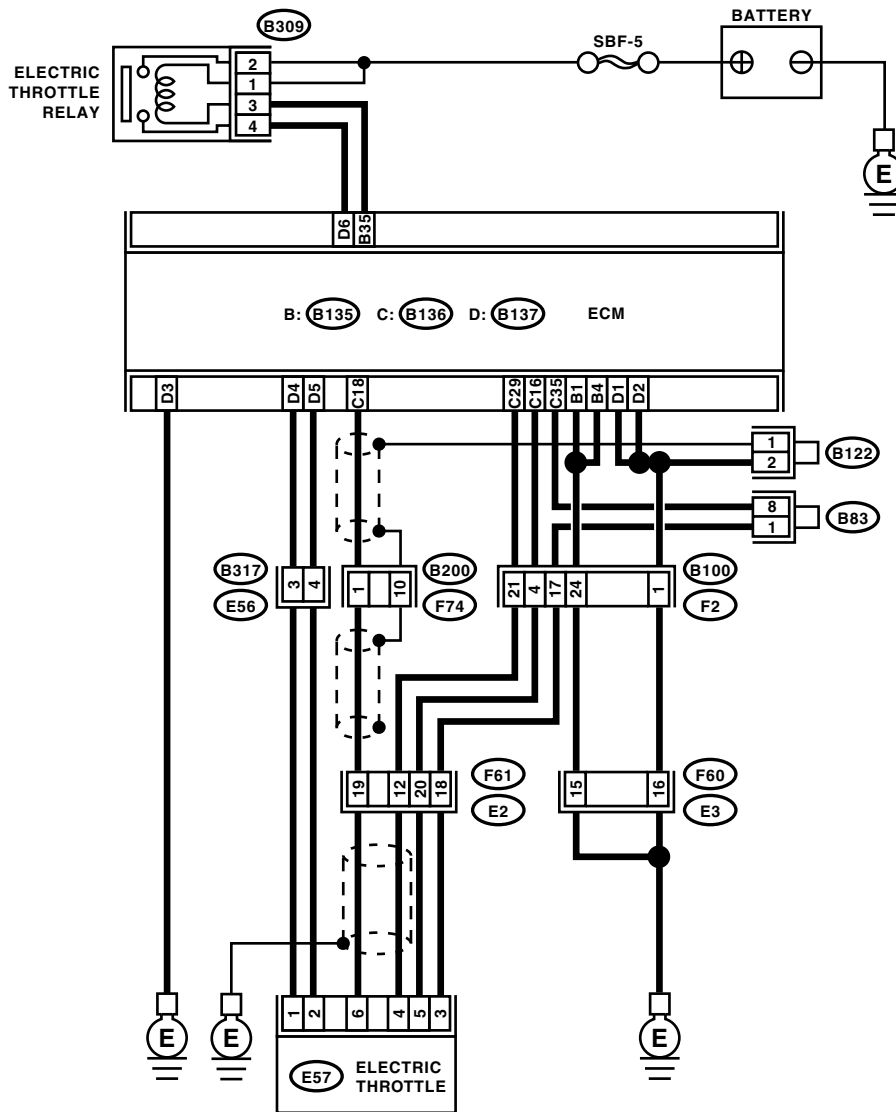

EN-01825

# DIAGNOSTIC PROCEDURE WITH DIAGNOSTIC TROUBLE CODE (DTC)

ENGINE (DIAGNOSTICS)

Step	Check	Yes	No
<p><b>1 CHECK OUTPUT VOLTAGE OF ACCELERATOR POSITION SENSOR.</b>                      1) Turn the ignition switch to ON.                      2) Measure the voltage between ECM connector terminals.  <i>Connector &amp; terminal</i>  <i>(B136) No. 18 (+) — (B136) No. 35 (-):</i>                      3) Shake the ECM harness and connector, engine harness connectors, electric throttle connector harness while monitoring value of voltage meter.</p>	<p>Is the voltage more than 0.4 V?</p>	<p>Go to step 2.</p>	<p>Go to step 4.</p>
<p><b>2 CHECK OUTPUT VOLTAGE OF ACCELERATOR POSITION SENSOR.</b>                      1) Measure the voltage between ECM connector terminals.  <i>Connector &amp; terminal</i>  <i>(B136) No. 29 (+) — (B136) No. 35 (-):</i>                      2) Shake the ECM harness and connector, engine harness connectors, electric throttle connector harness while monitoring value of voltage meter.</p>	<p>Is the voltage more than 0.8 V?</p>	<p>Go to step 3.</p>	<p>Go to step 4.</p>
<p><b>3 CHECK POOR CONTACT IN CONNECTORS.</b>                      Check poor contact in connectors between ECM and electric throttle.</p>	<p>Is there any poor contact in connectors between ECM and electric throttle?</p>	<p>Repair the poor contact in connectors.</p>	<p>Go to step 14.</p>
<p><b>4 CHECK HARNESS BETWEEN ECM AND ELECTRIC THROTTLE.</b>                      1) Turn the ignition switch to OFF.                      2) Disconnect the connector from ECM.                      3) Disconnect the connector from electric throttle.                      4) Measure the resistance between ECM connector and electric throttle connector.  <i>Connector &amp; terminal</i>  <i>(B136) No. 16 — (E57) No. 5:</i></p>	<p>Is the resistance less than 1 <math>\Omega</math>?</p>	<p>Go to step 5.</p>	<p>Repair the open harness connector.</p>
<p><b>5 CHECK HARNESS BETWEEN ECM AND ELECTRIC THROTTLE.</b>                      Measure the resistance between ECM connector and chassis ground.  <i>Connector &amp; terminal</i>  <i>(B136) No. 18 — Chassis ground:</i>  <i>(B136) No. 29 — Chassis ground:</i>  <i>(B136) No. 16 — Chassis ground:</i></p>	<p>Is the resistance more than 1 M<math>\Omega</math>?</p>	<p>Go to step 6.</p>	<p>Repair the ground short of harness.</p>
<p><b>6 CHECK POWER SUPPLY TO SENSOR.</b>                      1) Connect the ECM connector.                      2) Turn the ignition switch to ON.                      3) Measure the voltage between electric throttle connector and engine ground.  <i>Connector &amp; terminal</i>  <i>(E57) No. 5 (+) — Engine ground (-):</i>                      4) Shake the ECM harness and connector, engine harness connectors, while monitoring value of voltage meter.</p>	<p>Is the voltage 4.5 — 5.5 V?</p>	<p>Go to step 7.</p>	<p>Repair the poor contact in ECM connector. If problem persists, replace the ECM.</p>

# DIAGNOSTIC PROCEDURE WITH DIAGNOSTIC TROUBLE CODE (DTC)

## ENGINE (DIAGNOSTICS)

Step	Check	Yes	No
<b>7 CHECK SHORT OF ECM.</b> 1) Turn the ignition switch to OFF. 2) Measure the resistance between electric throttle connector and engine ground. <b>Connector &amp; terminal</b> (E57) No. 6 — Engine ground: (E57) No. 4 — Engine ground:	Is the resistance more than 10 $\Omega$ ?	Go to step 8.	Repair the poor contact in ECM connector. If problem persists, replace the ECM. <Ref. to FU(STi)-41, Engine Control Module (ECM).>
<b>8 CHECK OUTPUT VOLTAGE OF ACCELERATOR POSITION SENSOR.</b> 1) Connect all the connectors. 2) Turn the ignition switch to ON. 3) Read the data of main throttle sensor signals, using Subaru Select Monitors. 4) Shake the ECM harness and connector, engine harness connector, electric throttle connector harness while monitoring value of voltage meter.	Is the voltage less than 4.63 V?	Go to step 9.	Go to step 11.
<b>9 CHECK OUTPUT VOLTAGE OF ACCELERATOR POSITION SENSOR.</b> 1) Read the data of sub throttle sensor signals, using Subaru Select Monitors. 2) Shake the ECM harness and connector, engine harness connector, electric throttle connector harness while monitoring value of voltage meter.	Is the voltage less than 4.73 V?	Go to step 10.	Go to step 11.
<b>10 CHECK POOR CONTACT IN CONNECTORS.</b> Check poor contact in connectors between ECM and electric throttle.	Is there any poor contact in connectors between ECM and electric throttle?	Repair the poor contact in connectors.	Connector has returned to a normal condition at this time. A temporary poor contact in the connector might have been the cause.
<b>11 CHECK HARNESS BETWEEN ECM AND ELECTRIC THROTTLE.</b> 1) Turn the ignition switch to OFF. 2) Disconnect the connector from ECM. 3) Disconnect the connector from electric throttle. 4) Measure the resistance between ECM connector and electric throttle connector. <b>Connector &amp; terminal</b> (B136) No. 35 — (E57) No. 3: (B136) No. 18 — (E57) No. 6: (B136) No. 29 — (E57) No. 4:	Is the resistance less than 1 $\Omega$ ?	Go to step 12.	Repair the open harness connector.
<b>12 CHECK HARNESS BETWEEN ECM AND ELECTRIC THROTTLE.</b> 1) Connect the ECM connector. 2) Measure the resistance between electric throttle connector and engine ground. <b>Connector &amp; terminal</b> (E57) No. 3 — Engine ground:	Is the resistance less than 5 $\Omega$ ?	Go to step 13.	Repair the poor contact in ECM connector. If problem persists, replace the ECM.



# DIAGNOSTIC PROCEDURE WITH DIAGNOSTIC TROUBLE CODE (DTC)

ENGINE (DIAGNOSTICS)

Step	Check	Yes	No
<p><b>13 CHECK HARNESS BETWEEN ECM AND ELECTRIC THROTTLE.</b>                      1)Connect the ECM connector.                      2)Turn the ignition switch to ON.                      3)Measure the voltage between electric throttle connector and engine ground.  <i>Connector &amp; terminal</i>  <i>(E57) No. 5 (+) — Engine ground (-):</i>                      4)Shake the ECM harness and connector, engine harness connectors, while monitoring value of voltage meter.</p>	<p>Is the voltage more than 10 V?</p>	<p>Go to step 14.</p>	<p>Repair the battery short of harness between ECM connector and electric throttle connector.</p>
<p><b>14 CHECK HARNESS BETWEEN ECM AND ELECTRIC THROTTLE.</b>                      1)Measure the voltage between electric throttle connector and engine ground.  <i>Connector &amp; terminal</i>  <i>(E57) No. 6 (+) — Engine ground (-):</i>  <i>(E57) No. 4 (+) — Engine ground (-):</i>                      2)Shake the ECM harness and connector, engine harness connectors, while monitoring value of voltage meter.</p>	<p>Is the voltage less than 10 V?</p>	<p>Go to step 15.</p>	<p>Repair the short of harness between ECM connector and electric throttle connector.</p>
<p><b>15 CHECK HARNESS BETWEEN ECM AND ELECTRIC THROTTLE.</b>                      1)Turn the ignition switch to OFF.                      2)Disconnect the electric throttle connector.                      3)Measure the resistance between ECM connectors.  <i>Connector &amp; terminal</i>  <i>(B136) No. 18 (+) — (B136) No. 35 (-):</i>  <i>(B136) No. 29 (+) — (B136) No. 35 (-):</i></p>	<p>Is the resistance more than 1 MΩ?</p>	<p>Go to step 16.</p>	<p>Repair the short of power supply sensor.</p>
<p><b>16 CHECK ELECTRIC THROTTLE HARNESS.</b>                      1)Disconnect the connector from ECM.                      2)Disconnect the connector from electric throttle.                      3)Measure the resistance between electric throttle connector terminals.  <i>Connector &amp; terminal</i>  <i>(E57) No. 6 — (E57) No. 4:</i></p>	<p>Is the resistance more than 1 MΩ?</p>	<p>Repair the poor contact in ECM connector. If problem persists, replace the ECM.</p>	<p>Repair the short of harness.</p>

# DIAGNOSTIC PROCEDURE WITH DIAGNOSTIC TROUBLE CODE (DTC)

ENGINE (DIAGNOSTICS)

## DS:DTC P2138 — THROTTLE/PEDAL POSITION SENSOR/SWITCH “D”/“E” VOLTAGE RATIONALITY —

### • DTC DETECTING CONDITION:

- Immediately at fault recognition
- GENERAL DESCRIPTION <Ref. to GD(STi)-270, DTC P2138 — THROTTLE/PEDAL POSITION SENSOR/SWITCH “D”/“E” VOLTAGE RATIONALITY —, Diagnostic Trouble Code (DTC) Detecting Criteria.>

### • TROUBLE SYMPTOM:

- Erroneous idling
- Poor driving performance

### • WIRING DIAGRAM:

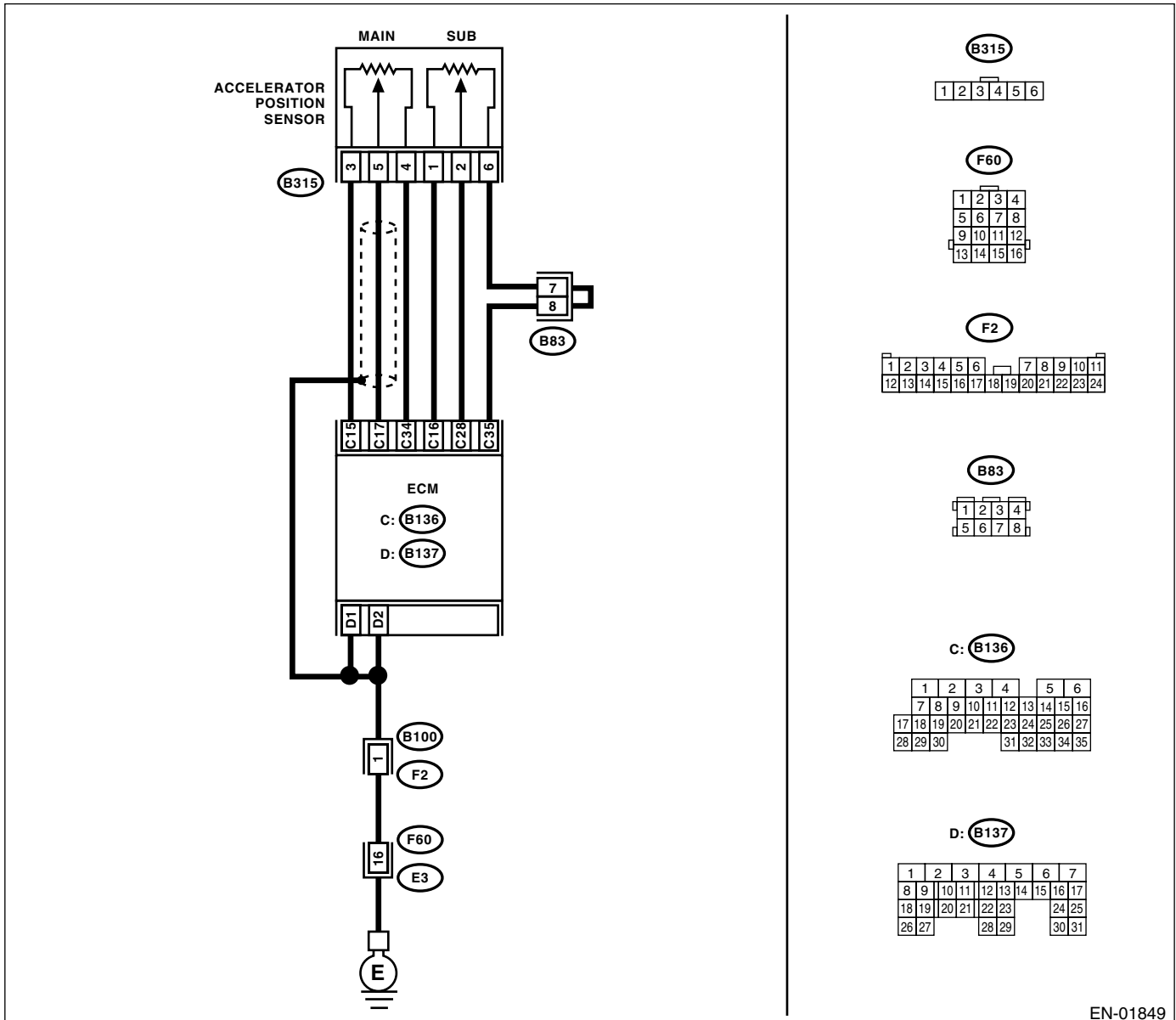

EN-01849

# DIAGNOSTIC PROCEDURE WITH DIAGNOSTIC TROUBLE CODE (DTC)

ENGINE (DIAGNOSTICS)

Step	Check	Yes	No
<p><b>1 CHECK OUTPUT VOLTAGE OF ACCELERATOR POSITION SENSOR.</b>                      1) Turn the ignition switch to ON.                      2) Measure the voltage between ECM connector terminals.  <i>Connector &amp; terminal</i>                      (B136) No. 17 (+) — (B136) No. 34 (-):                      (B136) No. 28 (+) — (B136) No. 35 (-):</p> <p>3) Shake the ECM harness and connector, accelerator position sensor connector and harness.</p>	<p>Is the voltage more than 0.4 V?</p>	<p>Go to step 2.</p>	<p>Go to step 3.</p>
<p><b>2 CHECK POOR CONTACT IN CONNECTORS.</b>                      Check poor contact in connectors between ECM and electric throttle.</p>	<p>Is there any poor contact in connectors between ECM and electric throttle?</p>	<p>Repair the poor contact in connectors.</p>	<p>Go to step 9.</p>
<p><b>3 CHECK HARNESS BETWEEN ECM AND ACCELERATOR POSITION SENSOR.</b>                      1) Turn the ignition switch to OFF.                      2) Disconnect the connector from ECM.                      3) Disconnect the connector from accelerator position sensor.                      4) Measure the resistance between ECM connector and accelerator position sensor connector.  <i>Connector &amp; terminal</i>                      (B136) No. 17 — (B315) No. 5:                      (B136) No. 15 — (B315) No. 3:                      (B136) No. 28 — (B315) No. 2:                      (B136) No. 16 — (B315) No. 1:</p>	<p>Is the resistance less than 1 Ω?</p>	<p>Go to step 4.</p>	<p>Repair the open harness connector.</p>
<p><b>4 CHECK HARNESS BETWEEN ECM AND ACCELERATOR POSITION SENSOR.</b>                      Measure the resistance between ECM connector and chassis ground.  <i>Connector &amp; terminal</i>                      (B136) No. 17 — Chassis ground:                      (B136) No. 15 — Chassis ground:                      (B136) No. 28 — Chassis ground:                      (B136) No. 16 — Chassis ground:</p>	<p>Is the resistance more than 1 MΩ?</p>	<p>Go to step 5.</p>	<p>Repair the ground short of harness.</p>
<p><b>5 CHECK POWER SUPPLY TO ACCELERATOR POSITION SENSOR.</b>                      1) Connect the ECM connector.                      2) Turn the ignition switch to ON.                      3) Measure the voltage between accelerator position sensor connector and engine ground.  <i>Connector &amp; terminal</i>                      (B315) No. 3 (+) — Engine ground (-):                      (B315) No. 1 (+) — Engine ground (-):</p> <p>4) Shake the ECM harness and connector, while monitoring value of voltage meter.</p>	<p>Is the voltage 4.5 — 5.5 V?</p>	<p>Go to step 6.</p>	<p>Repair the poor contact in ECM connector. If problem persists, replace the ECM.</p>
<p><b>6 CHECK ACCELERATOR POSITION SENSOR.</b>                      Measure the resistance of accelerator position sensor.  <i>Terminals</i>                      No. 3 — No. 4:</p>	<p>Is the resistance 1.2 — 4.8 kΩ?</p>	<p>Go to step 7.</p>	<p>Replace the accelerator position sensor.</p>

# DIAGNOSTIC PROCEDURE WITH DIAGNOSTIC TROUBLE CODE (DTC)

## ENGINE (DIAGNOSTICS)

Step	Check	Yes	No
7	<b>CHECK ACCELERATOR POSITION SENSOR.</b> Measure the resistance of accelerator position sensor. <i>Terminals</i> <i>No. 1 — No. 6:</i>	Is the resistance 0.75 — 3.15 kΩ?	Go to step 8. Replace the accelerator position sensor.
8	<b>CHECK ACCELERATOR POSITION SENSOR.</b> Measure the resistance of accelerator position sensor when the acceleration pedal is released. <i>Terminals</i> <i>No. 5 — No. 4:</i>	Is the resistance 0.2 — 0.8 kΩ?	Go to step 9. Replace the accelerator position sensor.
9	<b>CHECK ACCELERATOR POSITION SENSOR.</b> Measure the resistance of accelerator position sensor when the acceleration pedal is released. <i>Connector &amp; terminal</i> <i>No. 2 — No. 6:</i>	Is the resistance 0.15 — 0.63 kΩ?	Go to step 10. Replace the accelerator position sensor.
10	<b>CHECK ACCELERATOR POSITION SENSOR.</b> Measure the resistance of accelerator position sensor when the acceleration pedal is being depressed. <i>Terminals</i> <i>No. 5 — No. 4:</i>	Is the resistance 0.5 — 2.5 kΩ?	Go to step 11. Replace the accelerator position sensor.
11	<b>CHECK ACCELERATOR POSITION SENSOR.</b> Measure the resistance of accelerator position sensor when the acceleration pedal is being depressed. <i>Terminals</i> <i>No. 2 — No. 6: (Sub)</i>	Is the resistance 0.28 — 1.68 kΩ?	Go to step 12. Replace the accelerator position sensor.
12	<b>CHECK OUTPUT VOLTAGE OF ACCELERATOR POSITION SENSOR.</b> 1) Turn the ignition switch to OFF. 2) Connect all the connectors. 3) Turn the ignition switch to ON. 4) Read the data of main accelerator position sensor signals and sub accelerator position sensor signals, using Subaru Select Monitor. 5) Shake the ECM harness and connector, engine harness connector, accelerator position sensor connector harness while monitoring value of voltage meter.	Is the voltage less than 4.8 V?	Go to step 13. Go to step 14.
13	<b>CHECK POOR CONTACT IN CONNECTORS.</b> Check poor contact in connectors between ECM and electric throttle.	Is there any poor contact in connectors between ECM and electric throttle?	Repair the poor contact in connectors. Go to step 19.

# DIAGNOSTIC PROCEDURE WITH DIAGNOSTIC TROUBLE CODE (DTC)

## ENGINE (DIAGNOSTICS)

Step	Check	Yes	No
<b>14 CHECK HARNESS BETWEEN ECM AND ACCELERATOR POSITION SENSOR.</b> 1) Turn the ignition switch to OFF. 2) Disconnect the connector from ECM. 3) Disconnect the connector from accelerator position sensor. 4) Measure the resistance between ECM connector and accelerator position sensor connector.  <i>Connector &amp; terminal</i> <i>(B136) No. 34 — (B315) No. 4:</i> <i>(B136) No. 35 — (B315) No. 6:</i>	Is the resistance less than 1 $\Omega$ ?	Go to step 15.	Repair the open harness connector.
<b>15 CHECK HARNESS BETWEEN ECM AND ACCELERATOR POSITION SENSOR.</b> 1) Connect the ECM connector. 2) Measure the resistance between accelerator position sensor and engine ground.  <i>Connector &amp; terminal</i> <i>(B315) No. 4 — Engine ground:</i> <i>(B315) No. 6 — Engine ground:</i>	Is the resistance less than 5 $\Omega$ ?	Go to step 16.	Repair the poor contact in ECM connector. If problem persists, replace the ECM.
<b>16 CHECK HARNESS BETWEEN ECM AND ACCELERATOR POSITION SENSOR.</b> 1) Connect the ECM connector. 2) Turn the ignition switch to ON. 3) Measure the voltage between accelerator position sensor and engine ground.  <i>Connector &amp; terminal</i> <i>(B315) No. 3 (+) — Engine ground (-):</i> <i>(B315) No. 1 (+) — Engine ground (-):</i>  4) Shake the ECM harness and connector, while monitoring value of voltage meter.	Is the voltage less than 6 V?	Go to step 17.	Repair the battery short of harness between ECM connector and accelerator position sensor.
<b>17 CHECK POWER SUPPLY TO ACCELERATOR POSITION SENSOR.</b> 1) Measure the voltage between accelerator position sensor connector and engine ground.  <i>Connector &amp; terminal</i> <i>(B315) No. 5 (+) — Engine ground (-):</i> <i>(B315) No. 2 (+) — Engine ground (-):</i>  2) Shake the ECM harness and connector, while monitoring value of voltage meter.	Is the voltage less than 4.8 V?	Go to step 18.	Repair the short of harness between ECM connector and accelerator position sensor connector.
<b>18 CHECK HARNESS BETWEEN ECM AND ACCELERATOR POSITION SENSOR.</b> 1) Turn the ignition switch to OFF. 2) Connect the accelerator position sensor connector. 3) Turn the ignition switch to ON. 4) Measure the voltage between ECM connector and chassis ground.  <i>Connector &amp; terminal</i> <i>(B136) No. 17 (+) — Chassis ground (-):</i> <i>(B136) No. 28 (+) — Chassis ground (-):</i>	Is the voltage less than 4.8 V?	Go to step 19.	Repair the poor contact in accelerator position sensor connector. If problem persists, replace the accelerator position sensor.

# DIAGNOSTIC PROCEDURE WITH DIAGNOSTIC TROUBLE CODE (DTC)

ENGINE (DIAGNOSTICS)

Step	Check	Yes	No
<b>19</b> <b>CHECK HARNESS BETWEEN ECM AND ACCELERATOR POSITION SENSOR.</b> 1) Turn the ignition switch to OFF. 2) Disconnect the connector from ECM. 3) Disconnect the connector from accelerator position sensor. 4) Measure the resistance between terminals of accelerator position sensor connector. <b>Connector &amp; terminal</b> <b>(B315) No. 5 — (B315) No. 2:</b>	Is the resistance less than 1 MΩ?	Repair the poor contact in ECM connector. If problem persists, replace the ECM.	Repair the short of harness between accelerator position sensor connector and accelerator position sensor connector.

## 19. General Diagnostic Table

### A: INSPECTION

#### 1. ENGINE

**NOTE:**

Malfunction of parts other than those listed is also possible. <Ref. to ME(STi)-94, Engine Trouble in General.>

Symptom	Problem parts
1. Engine stalls during idling.	1) Electric throttle 2) Manifold absolute pressure sensor 3) Mass air flow and intake temperature sensor 4) Ignition parts (*1) 5) Engine coolant temperature sensor (*2) 6) Crankshaft position sensor (*3) 7) Camshaft position sensor (*3) 8) Fuel injection parts (*4)
2. Rough idling	1) Electric throttle 2) Manifold absolute pressure sensor 3) Mass air flow and intake temperature sensor 4) Engine coolant temperature sensor (*2) 5) Ignition parts (*1) 6) Air intake system (*5) 7) Fuel injection parts (*4) 8) Crankshaft position sensor (*3) 9) Camshaft position sensor (*3) 10) Oxygen sensor 11) Fuel pump and fuel pump relay
3. Engine does not return to idle.	1) Electric throttle 2) Engine coolant temperature sensor 3) Manifold absolute pressure sensor 4) Mass air flow sensor
4. Poor acceleration	1) Manifold absolute pressure sensor 2) Mass air flow and intake temperature sensor 3) Electric throttle 4) Fuel injection parts (*4) 5) Fuel pump and fuel pump relay 6) Engine coolant temperature sensor (*2) 7) Crankshaft position sensor (*3) 8) Camshaft position sensor (*3) 9) A/C switch and A/C cut relay 10) Engine torque control signal circuit 11) Ignition parts (*1)
5. Engine stalls or engine sags or hesitates at acceleration.	1) Manifold absolute pressure sensor 2) Mass air flow and intake temperature sensor 3) Engine coolant temperature sensor (*2) 4) Crankshaft position sensor (*3) 5) Camshaft position sensor (*3) 6) Purge control solenoid valve 7) Fuel injection parts (*4) 8) Fuel pump and fuel pump relay
6. Surge	1) Manifold absolute pressure sensor 2) Mass air flow and intake temperature sensor 3) Engine coolant temperature sensor (*2) 4) Crankshaft position sensor (*3) 5) Camshaft position sensor (*3) 6) Fuel injection parts (*4) 7) Throttle position sensor 8) Fuel pump and fuel pump relay

# GENERAL DIAGNOSTIC TABLE

## ENGINE (DIAGNOSTICS)

Symptom	Problem parts
7. Spark knock	1) Manifold absolute pressure sensor 2) Mass air flow and intake temperature sensor 3) Engine coolant temperature sensor 4) Knock sensor 5) Fuel injection parts (*4) 6) Fuel pump and fuel pump relay
8. After-burning in exhaust system	1) Manifold absolute pressure sensor 2) Mass air flow and intake temperature sensor 3) Engine coolant temperature sensor (*2) 4) Fuel injection parts (*4) 5) Fuel pump and fuel pump relay

\*1: Check ignition coil & ignitor ASSY and spark plug.

\*2: Indicate the symptom occurring only in cold temperatures.

\*3: Ensure the secure installation.

\*4: Check fuel injector, fuel pressure regulator and fuel filter.

\*5: Inspect air leak in air intake system.