

Brought to you by Eris Studios
NOT FOR RESALE

FUEL INJECTION (FUEL SYTEMS)

GENERAL DESCRIPTION

FUEL INJECTION (FUEL SYSTEMS)

1. General Description

A: SPECIFICATIONS

Fuel tank	Capacity	60 ℓ (15.9 US gal, 13.2 Imp gal)
	Location	Under rear seat
Fuel pump	Type	Impeller
	Shutoff discharge pressure	450 — 677 kPa (4.59 — 6.9 kg/cm ² , 65.27 — 98.2 psi)
	Discharge flow	More than 145 ℓ (38.3 US gal, 31.9 Imp gal)/h [12 V at 300 kPa (3.06 kg/cm ² , 43.5 psi)]
Fuel filter		Cartridge type

GENERAL DESCRIPTION

FUEL INJECTION (FUEL SYSTEMS)

B: COMPONENT

1. INTAKE MANIFOLD

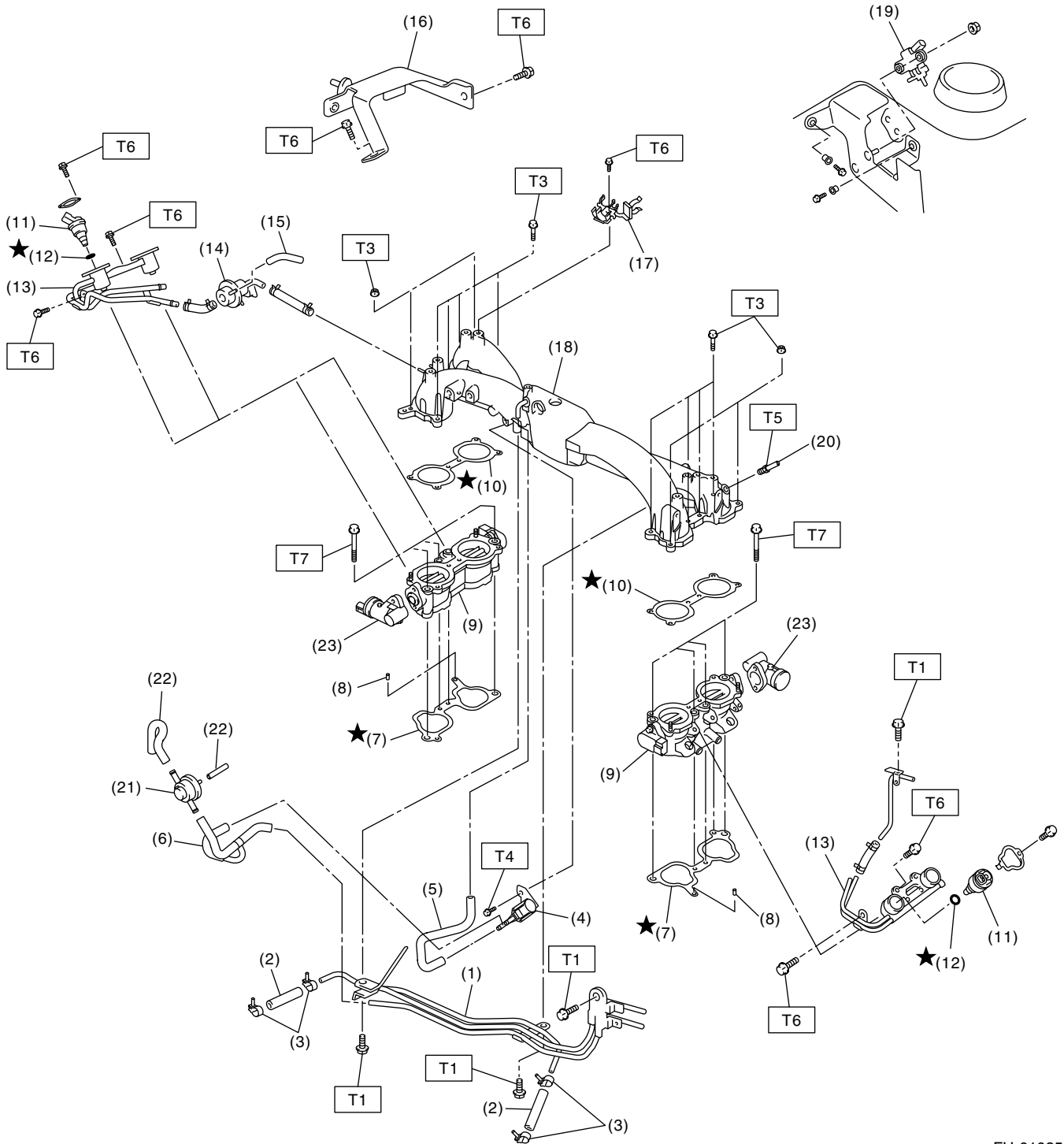

FU-01035

GENERAL DESCRIPTION

FUEL INJECTION (FUEL SYSTEMS)

- | | |
|------------------------------------|--|
| (1) Fuel pipe ASSY | (13) Fuel injector pipe |
| (2) Fuel hose | (14) Pressure regulator |
| (3) Clip | (15) Pressure regulator hose |
| (4) Purge control solenoid valve | (16) Fuel pipe protector RH |
| (5) Vacuum hose | (17) Blow-by hose stay |
| (6) Vacuum control hose | (18) Intake manifold |
| (7) Intake manifold gasket | (19) Wastegate control solenoid valve ASSY |
| (8) Guide pin | (20) Nipple |
| (9) Tumble generator valve ASSY | (21) Purge valve |
| (10) Tumble generator valve gasket | (22) Purge hose |
| (11) Fuel injector | (23) Tumble generator valve actuator |
| (12) O-ring | |

Tightening torque: N·m (kgf-m, ft-lb)

T1: 4.9 (0.5, 3.6)

T2: 6.4 (0.65, 4.7)

T3: 8.25 (0.84, 6.1)

T4: 16 (1.6, 11.8)

T5: 17 (1.73, 12.5)

T6: 19 (1.94, 13.7)

T7: 25 (2.5, 18.1)

GENERAL DESCRIPTION

FUEL INJECTION (FUEL SYSTEMS)

2. AIR INTAKE SYSTEM

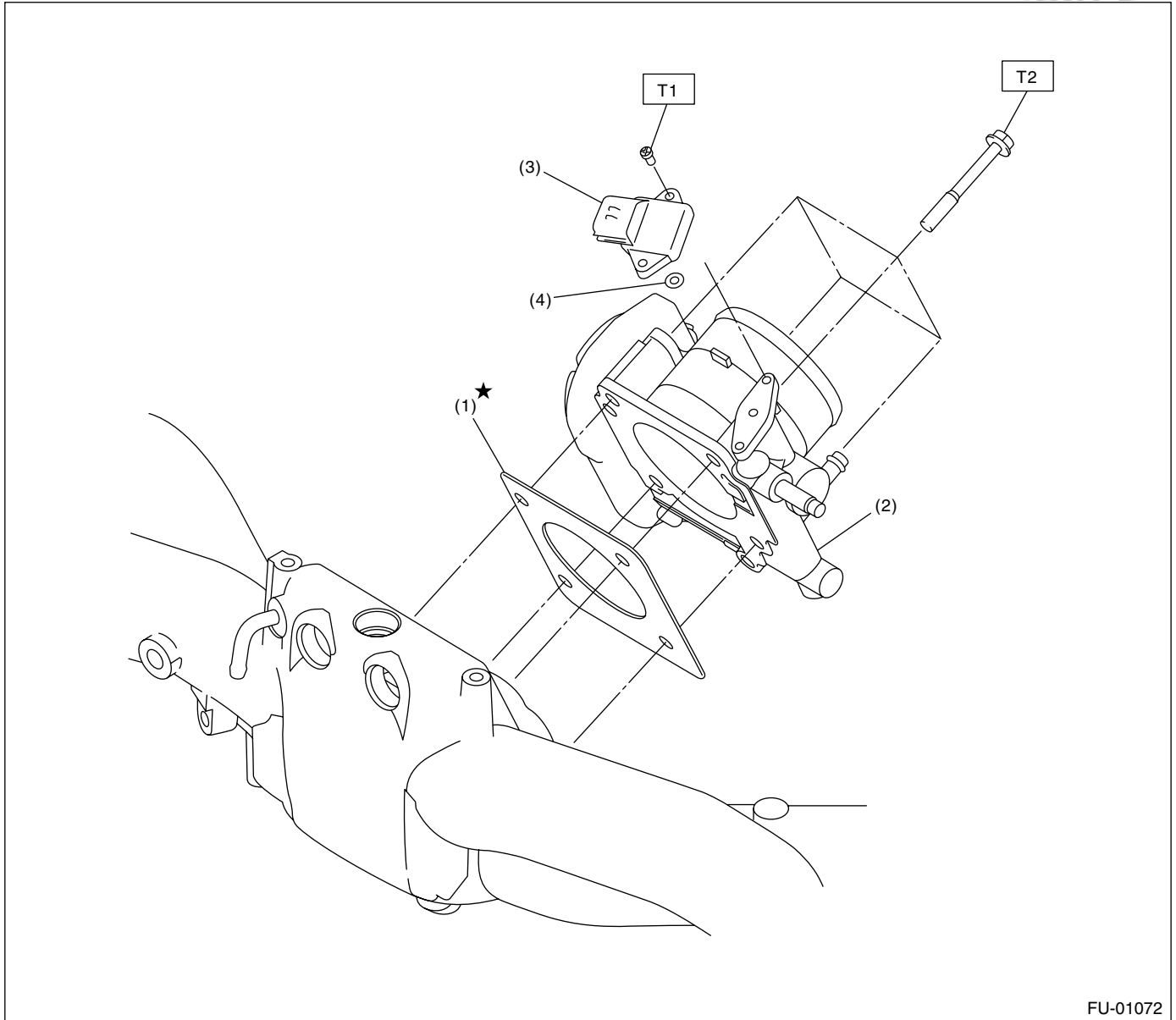

FU-01072

- (1) Gasket
- (2) Throttle body

- (3) Manifold absolute pressure sensor
- (4) O-ring

Tightening torque: N·m (kgf·m, ft·lb)

T1: 1.6 (0.16, 1.2)

T2: 8 (0.8, 5.8)

GENERAL DESCRIPTION

FUEL INJECTION (FUEL SYSTEMS)

3. CRANKSHAFT POSITION, CAMSHAFT POSITION AND KNOCK SENSORS

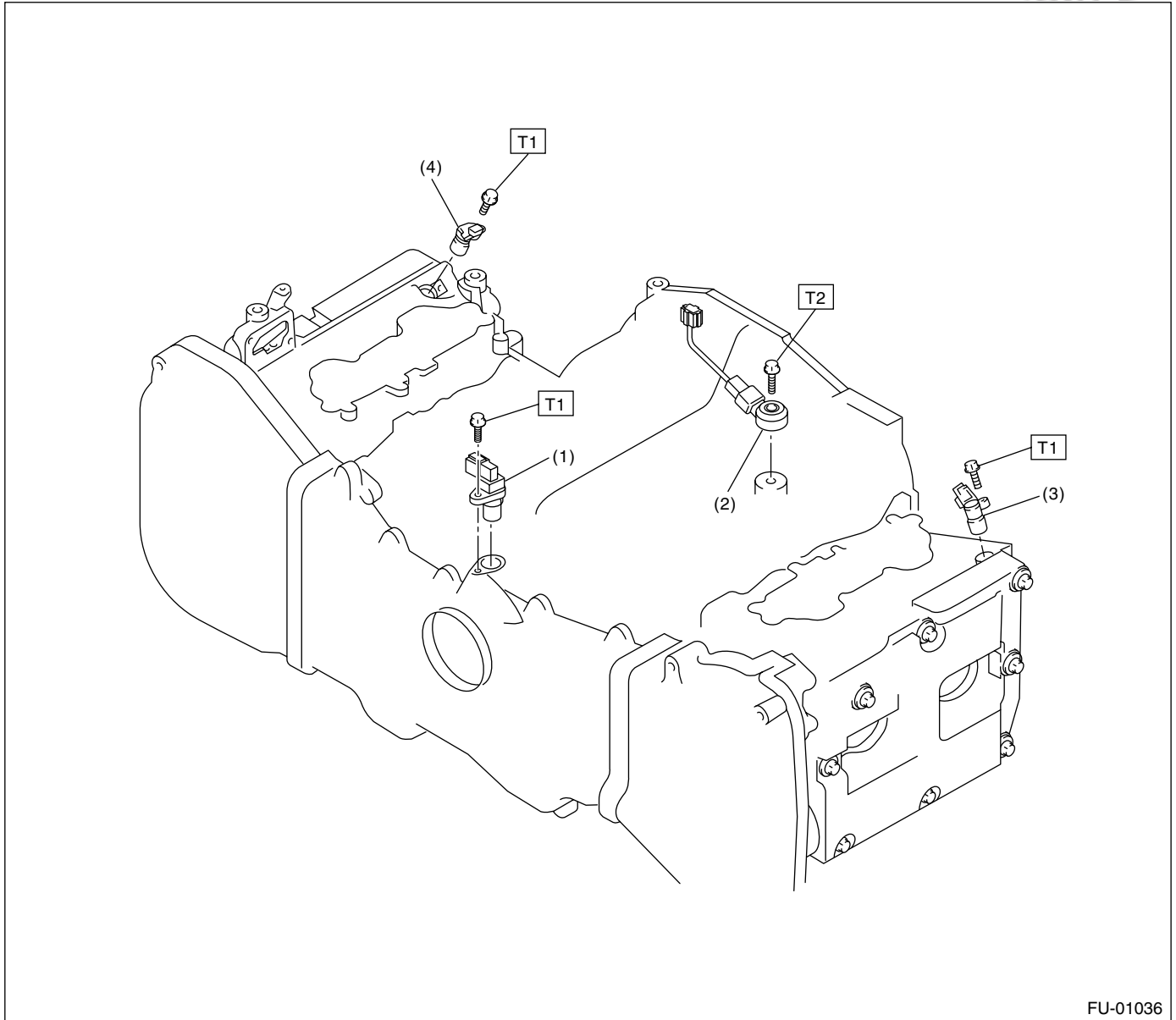

FU-01036

- (1) Crankshaft position sensor
- (2) Knock sensor

- (3) Camshaft position sensor LH
- (4) Camshaft position sensor RH

Tightening torque: N·m (kgf·m, ft·lb)

T1: 6.4 (0.65, 4.7)

T2: 24 (2.4, 17.4)

GENERAL DESCRIPTION

FUEL INJECTION (FUEL SYSTEMS)

4. FUEL TANK

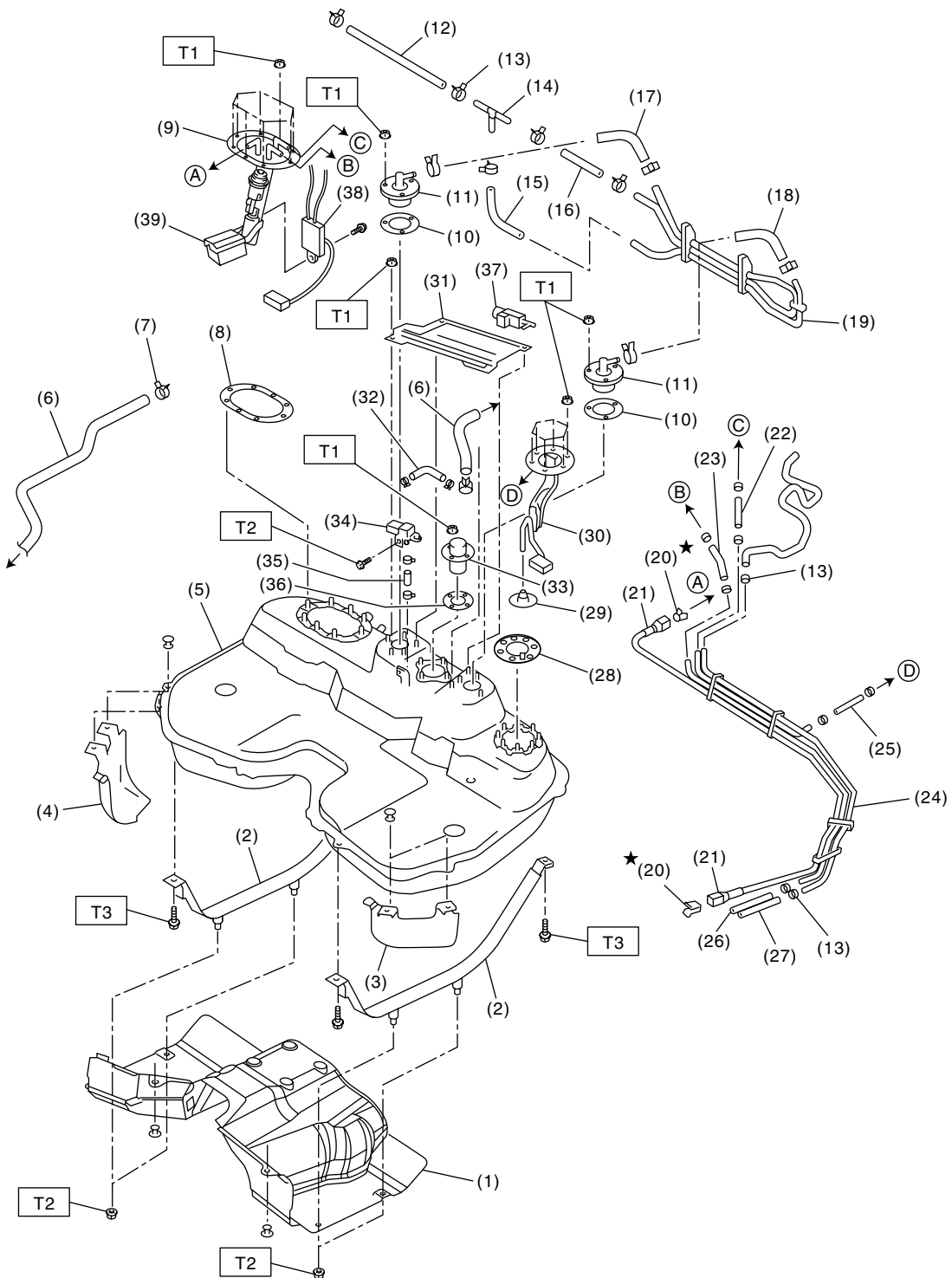

FU-01060

GENERAL DESCRIPTION

FUEL INJECTION (FUEL SYSTEMS)

(1) Heat shield cover	(16) Evaporation hose B	(31) Protector cover
(2) Fuel tank band	(17) Evaporation hose D	(32) Vent valve hose
(3) Protector LH	(18) Evaporation hose E	(33) Vent valve
(4) Protector RH	(19) Evaporation pipe ASSY	(34) Fuel tank pressure sensor
(5) Fuel tank	(20) Retainer	(35) Fuel tank pressure sensor hose
(6) Canister hose A	(21) Quick connector	(36) Vent valve gasket
(7) Clamp	(22) Jet pump hose A	(37) Fuel tank sensor control valve
(8) Fuel pump gasket	(23) Fuel return hose A	(38) Fuel level sensor
(9) Fuel pump ASSY	(24) Fuel pipe ASSY	(39) Fuel filter
(10) Fuel cut valve gasket	(25) Jet pump hose B	
(11) Fuel cut valve	(26) Fuel return hose B	
(12) Evaporation hose A	(27) Evaporation hose F	
(13) Clip	(28) Fuel sub level sensor gasket	
(14) Joint pipe	(29) Jet pump filter	
(15) Evaporation hose C	(30) Fuel sub level sensor	

Tightening torque: N·m (kgf-m, ft-lb)

T1: 4.4 (0.45, 3.3)

T2: 7.4 (0.75, 5.4)

T3: 33 (3.4, 25)

GENERAL DESCRIPTION

FUEL INJECTION (FUEL SYSTEMS)

5. FUEL LINE

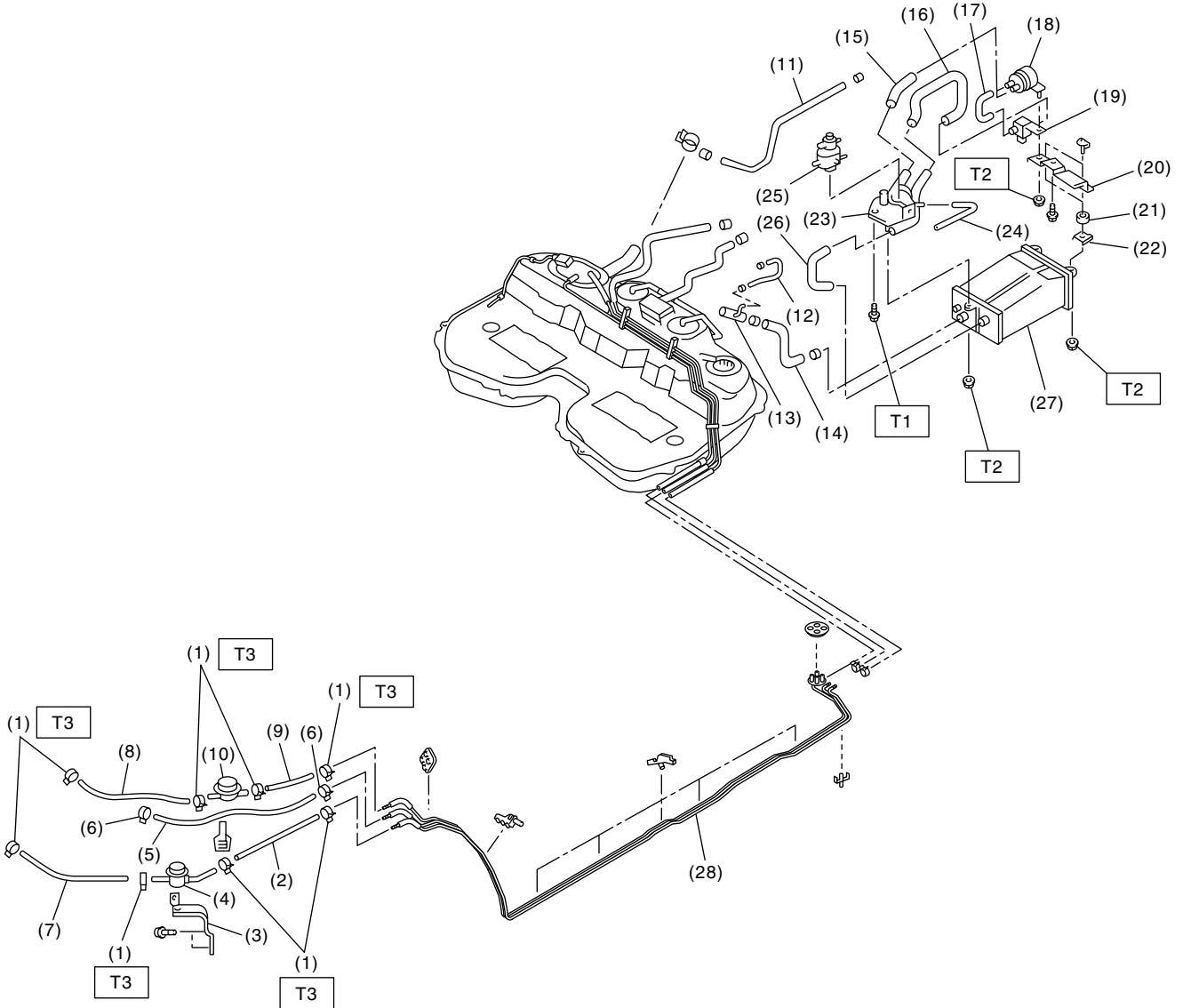

FU-01069

GENERAL DESCRIPTION

FUEL INJECTION (FUEL SYSTEMS)

- | | | |
|----------------------------|-----------------------------|--------------------------------------|
| (1) Clamp | (13) Joint pipe | (25) Pressure control solenoid valve |
| (2) Fuel delivery hose A | (14) Canister hose A | (26) Canister hose B |
| (3) Hose bracket | (15) Air filter hose A | (27) Canister |
| (4) Fuel damper (delivery) | (16) Drain valve hose | (28) Fuel pipe ASSY |
| (5) Evaporation hose | (17) Air filter hose B | |
| (6) Clip | (18) Drain filter | |
| (7) Fuel delivery hose B | (19) Drain valve | |
| (8) Fuel return hose A | (20) Canister upper bracket | |
| (9) Fuel return hose B | (21) Cushion rubber | |
| (10) Fuel damper (return) | (22) Canister lower bracket | |
| (11) Evaporation hose J | (23) Canister holder | |
| (12) Evaporation hose K | (24) Evaporation hose L | |

Tightening torque: N·m (kgf-m, ft-lb)

T1: 25 (2.5, 18.1)

T2: 23 (2.3, 16.6)

T3: 1.25 (0.13, 0.94)

GENERAL DESCRIPTION

FUEL INJECTION (FUEL SYSTEMS)

6. FUEL FILLER PIPE

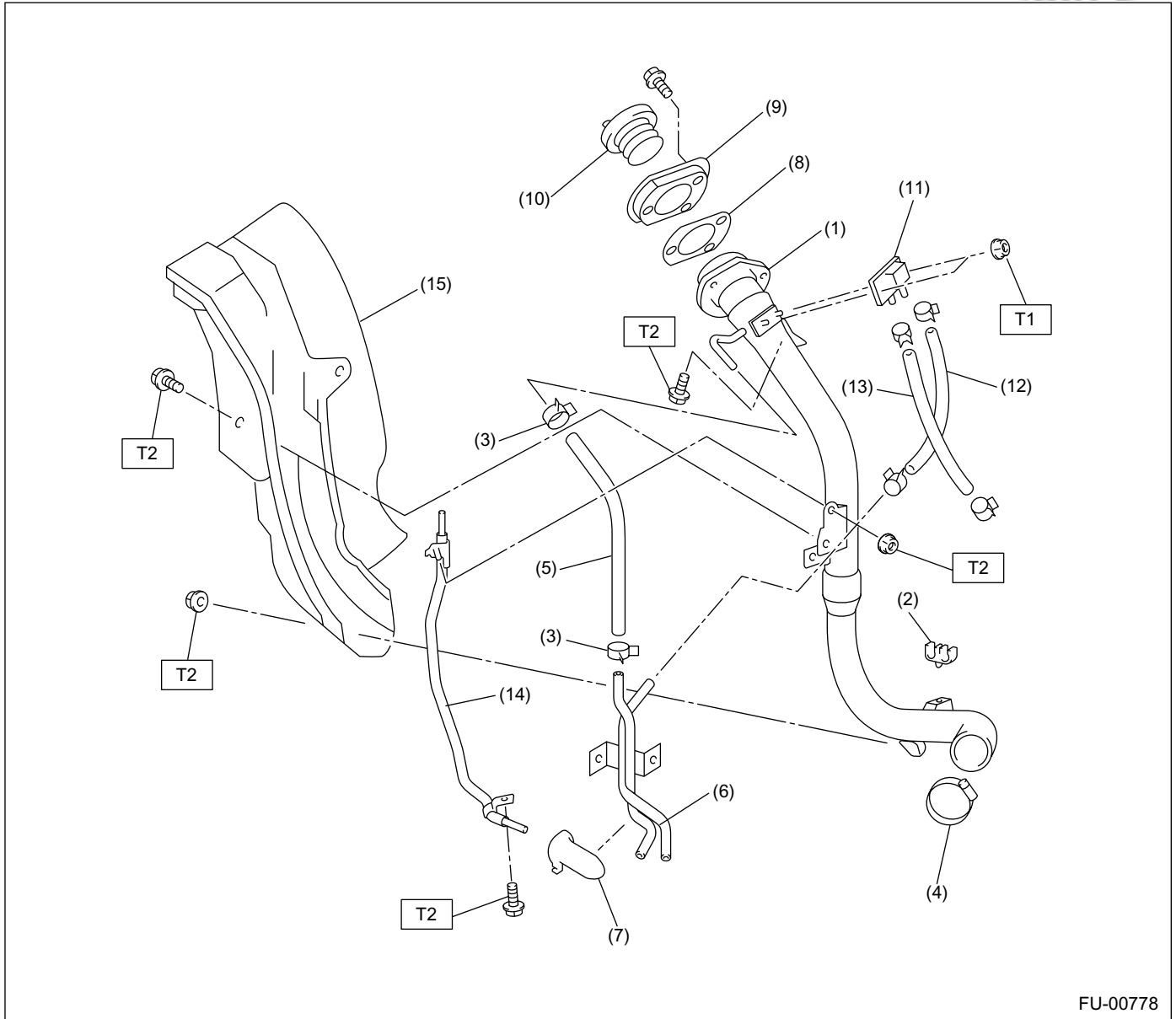

FU-00778

- | | | |
|-----------------------------|-------------------------|---------------------------------|
| (1) Fuel filler pipe ASSY | (8) Filler pipe packing | (15) Fuel filler pipe protector |
| (2) Evaporation hose holder | (9) Filler ring | |
| (3) Clip | (10) Filler cap | |
| (4) Clamp | (11) Shut valve | |
| (5) Evaporation hose A | (12) Evaporation hose B | |
| (6) Evaporation pipe | (13) Evaporation hose C | |
| (7) Evaporation pipe holder | (14) Joint pipe | |

Tightening torque: N·m (kgf·m, ft·lb)

T1: 4.4 (0.45, 3.3)

T2: 7.5 (0.76, 5.5)

GENERAL DESCRIPTION



FUEL INJECTION (FUEL SYSTEMS)

C: CAUTION

- Wear working clothing, including a cap, protective goggles, and protective shoes during operation.
- Remove contamination including dirt and corrosion before removal, installation or disassembly.
- Keep the disassembled parts in order and protect them from dust or dirt.
- Before removal, installation or disassembly, be sure to clarify the failure. Avoid unnecessary removal, installation, disassembly, and replacement.

- Be careful not to burn your hands, because each part on the vehicle is hot after running.
- Be sure to tighten fasteners including bolts and nuts to the specified torque.
- Place shop jacks or safety stands at the specified points.
- Before disconnecting electrical connectors of sensors or units, be sure to disconnect negative terminal from battery.
- Place "NO FIRE" signs near the working area.
- Be careful not to spill fuel on the floor.

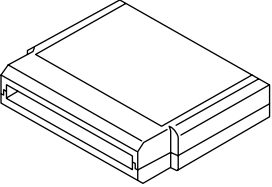
D: PREPARATION TOOL

ILLUSTRATION	TOOL NUMBER	DESCRIPTION	REMARKS
 ST24082AA230	24082AA230	CARTRIDGE	Troubleshooting for electrical system.
 ST22771AA030	22771AA030	SELECT MONITOR KIT	Troubleshooting for electrical systems.

2. Throttle Body

A: REMOVAL

1) Disconnect the ground cable from battery.

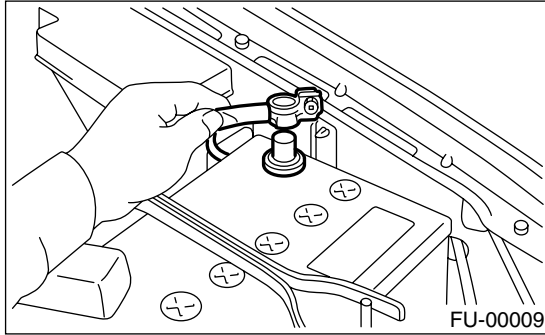

2) Remove the intercooler. <Ref. to IN(STi)-11, REMOVAL, Intercooler.>

3) Disconnect the connector from the throttle position sensor (A) and manifold absolute pressure sensor (B).

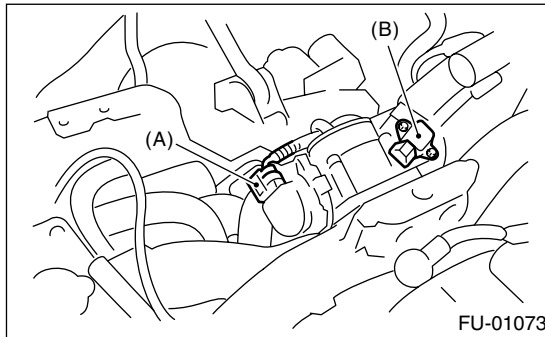

4) Disconnect the engine coolant hoses from the throttle body.

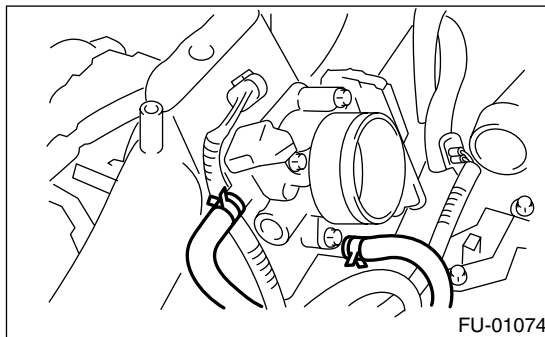

5) Remove the bolts which secure the throttle body to intake manifold.

B: INSTALLATION

Install in the reverse order of removal.

NOTE:

Always use a new gasket.

Tightening torque:

8 N·m (0.8 kgf-m, 5.8 ft-lb)

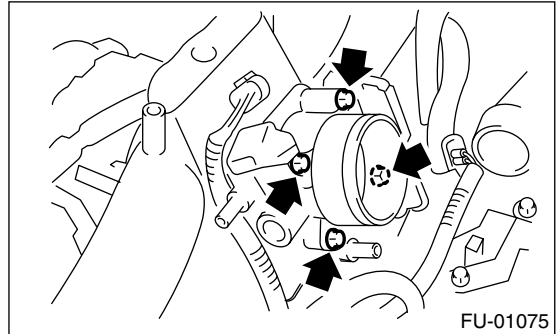

INTAKE MANIFOLD

FUEL INJECTION (FUEL SYSTEMS)

3. Intake Manifold

A: REMOVAL

- 1) Release the fuel pressure. <Ref. to FU(STi)-45, RELEASING OF FUEL PRESSURE, OPERATION, Fuel.>
- 2) Open the fuel filler lid and remove the fuel filler cap.
- 3) Disconnect the ground cable from battery.

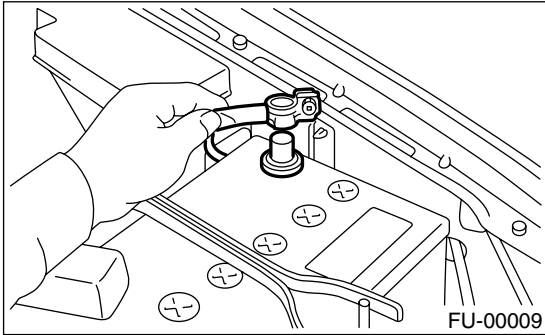

- 4) Lift up the vehicle.
- 5) Remove the under cover.
- 6) Drain the engine coolant about 3.0 ℓ (3.2 US qt, 2.6 Imp qt).

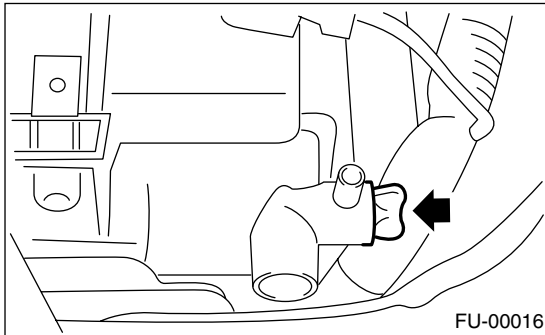

- 7) Remove the air cleaner upper cover and air intake boot. <Ref. to IN(STi)-8, REMOVAL, Air Cleaner.>
- 8) Remove the air cleaner element.
- 9) Remove the intercooler. <Ref. to IN(STi)-11, REMOVAL, Intercooler.>
- 10) Remove the coolant filler tank. <Ref. to CO(H4DOTC)-32, REMOVAL, Coolant Filler Tank.>
- 11) Remove the power steering pump.
 - (1) Remove the front side V-belt. <Ref. to ME(STi)-41, REMOVAL, V-belt.>

- (2) Disconnect the power steering switch connector.

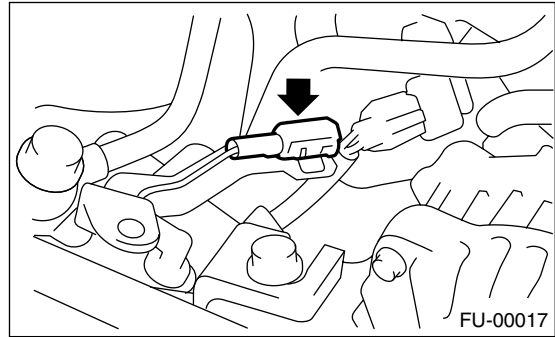

- (3) Remove the bolts which secure the power steering pipe brackets to the intake manifold.

NOTE:
Do not disconnect the power steering hose.

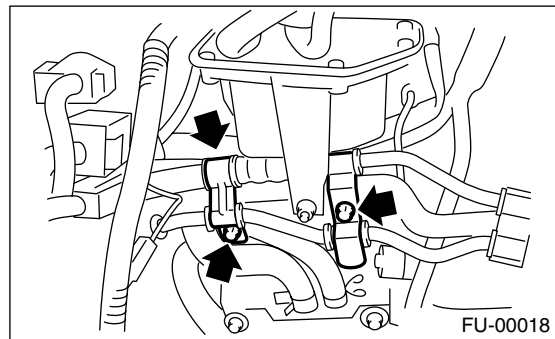

- (4) Remove the bolts which secure the power steering pump bracket.

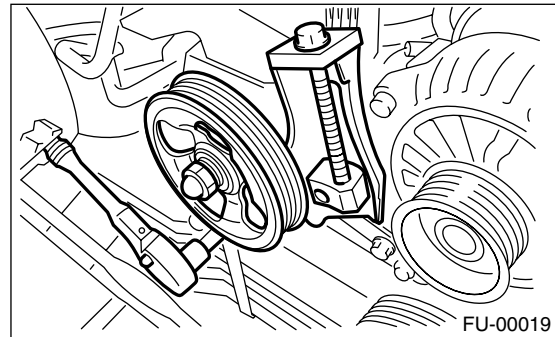

- (5) Remove the power steering tank from the bracket by pulling it upward.

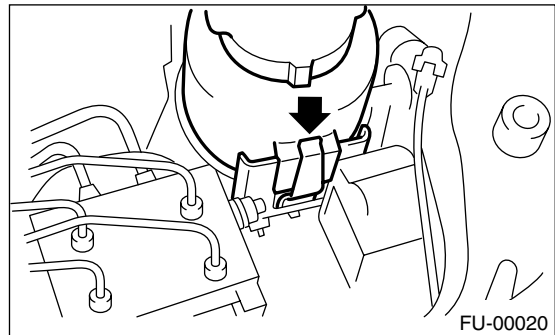

INTAKE MANIFOLD

FUEL INJECTION (FUEL SYSTEMS)

6) Place the power steering pump on the right side wheel apron.

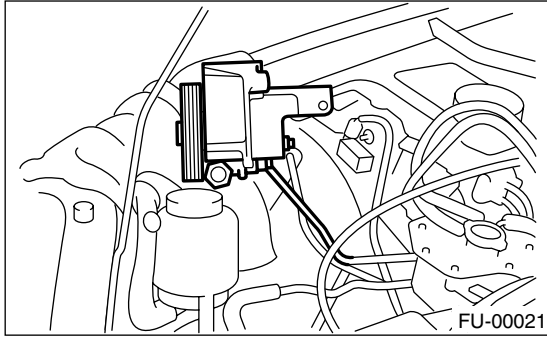

15) Disconnect the pressure hose from the intake duct.

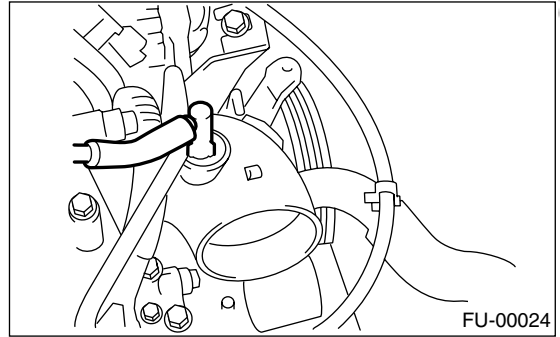

12) Disconnect the emission hose (A) and connector (B) from the PCV hose assembly.

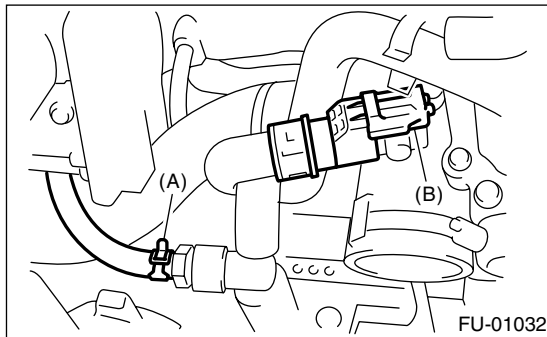

16) Disconnect the engine harness connectors from the bulkhead harness connectors.

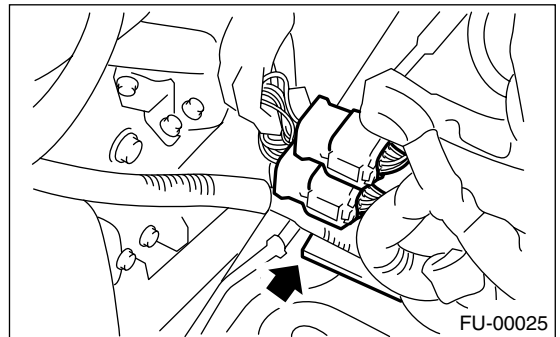

13) Disconnect the engine coolant hoses from the throttle body.

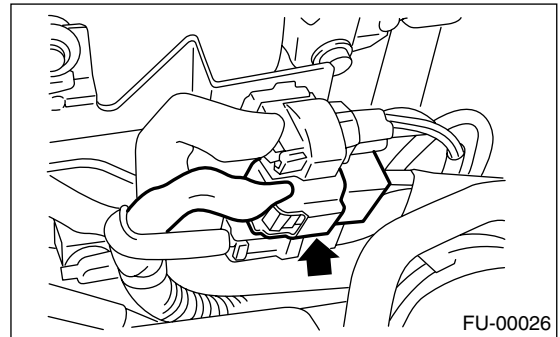
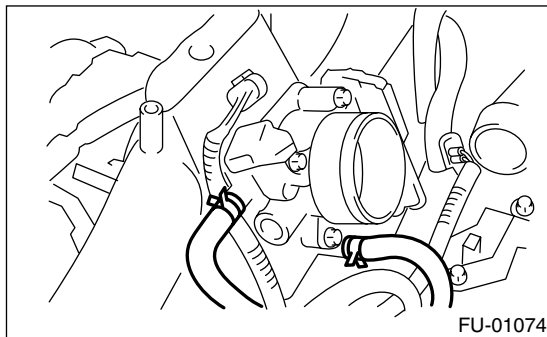

14) Disconnect the brake booster hose.

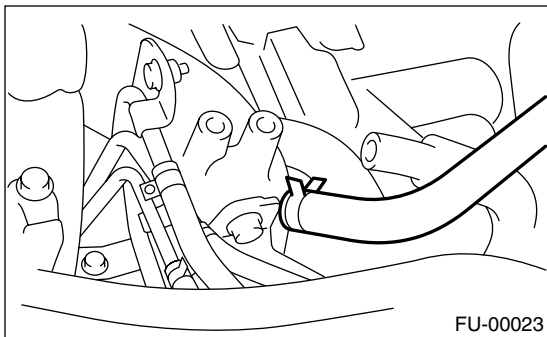

17) Disconnect the connectors from the engine coolant temperature sensor (A), oil pressure switch (B) and crankshaft position sensor (C).

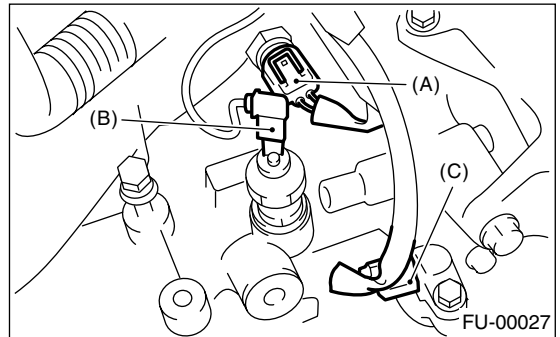

INTAKE MANIFOLD

FUEL INJECTION (FUEL SYSTEMS)

18) Disconnect the knock sensor connector.

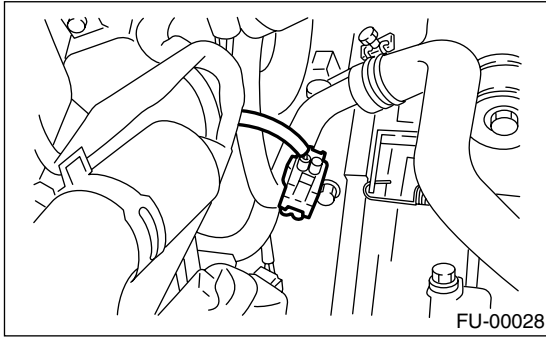

19) Disconnect the connector from the camshaft position sensor.

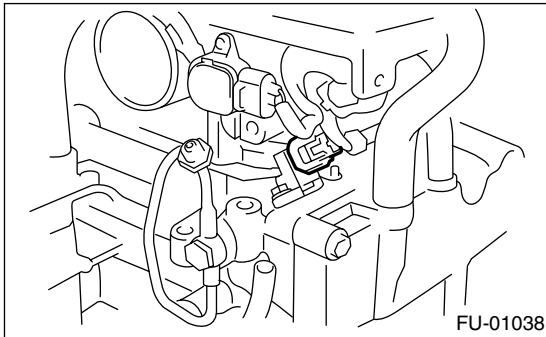

20) Disconnect the connector from the ignition coil.

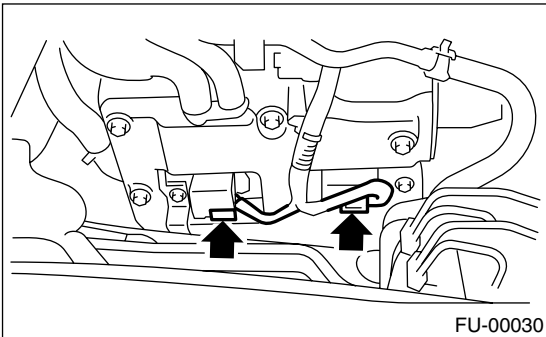

21) Disconnect the engine harness fixed by clip (A) from the bracket.

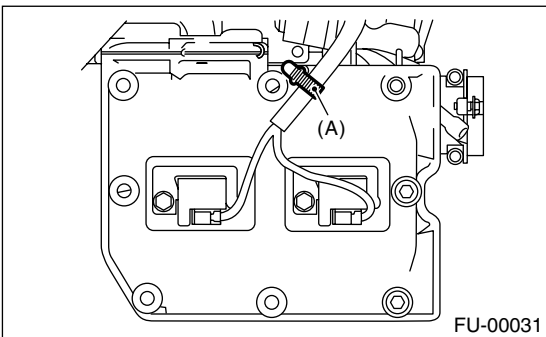

22) Disconnect the fuel delivery hose, return hose and evaporation hose.

CAUTION:

- Do not spill fuel.
- Catch fuel from hoses in a container or cloth.

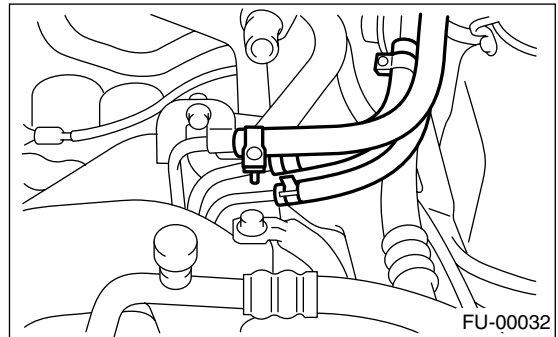

23) Remove the bolts which secure the intake manifold to the cylinder heads.

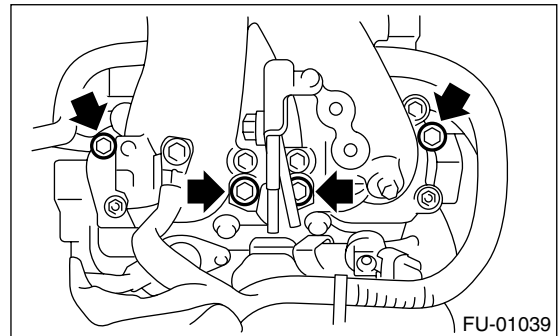

24) Remove the intake manifold.

B: INSTALLATION

1) Install the intake manifold onto cylinder heads.

NOTE:

Always use new gaskets.

Tightening torque:

25 N·m (2.5 kgf·m, 18.1 ft·lb)

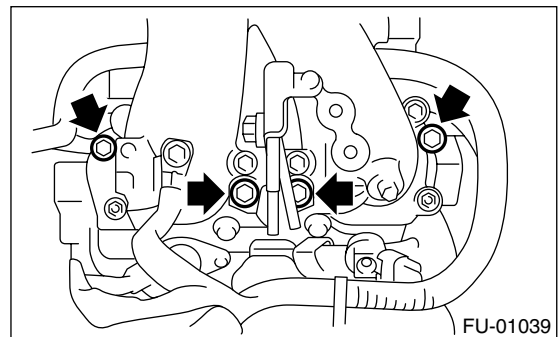

INTAKE MANIFOLD

FUEL INJECTION (FUEL SYSTEMS)

2) Connect the fuel delivery hose, return hose and evaporation hose.

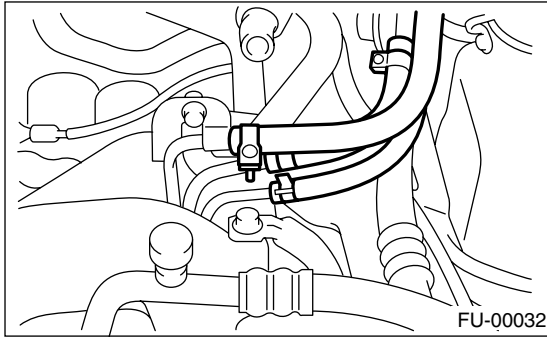

3) Connect the connector to the oil pressure switch (B), crankshaft position sensor (C) and engine coolant temperature sensor (A).

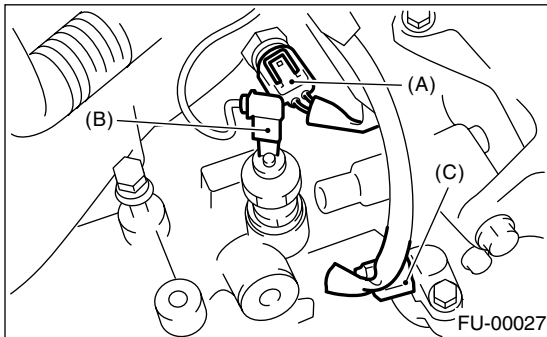

4) Connect the connector to the knock sensor.

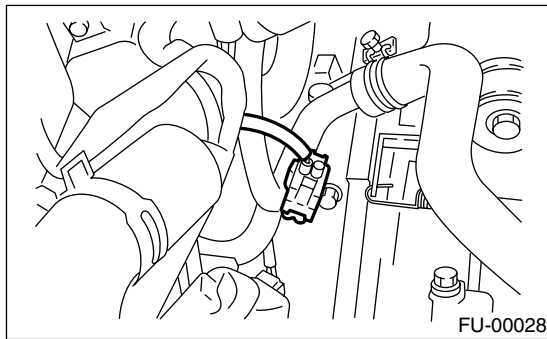

5) Connect the connector to the camshaft position sensor.

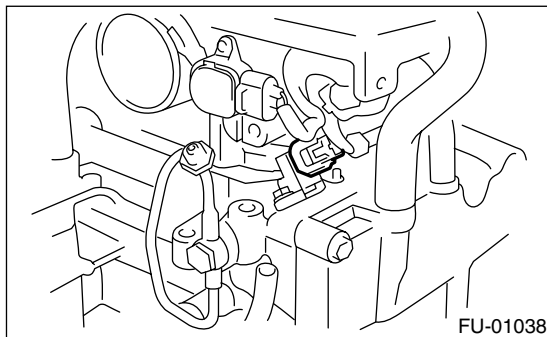

6) Connect the connector to the ignition coil.

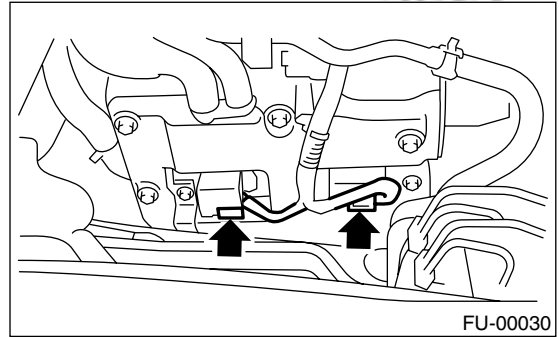

7) Connect the engine harness with clip (A) to the bracket.

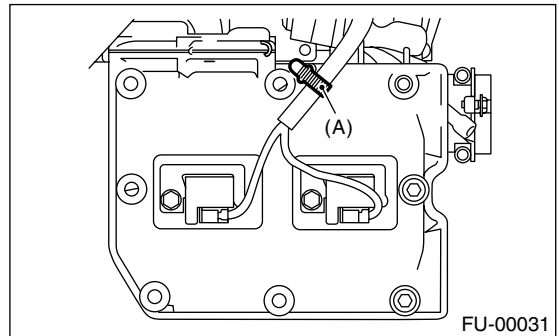

8) Connect the engine harness connector to the bulkhead harness connectors.

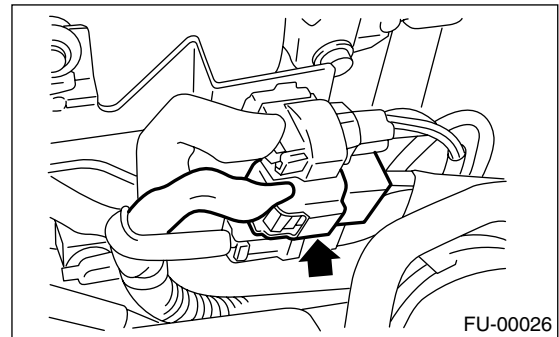
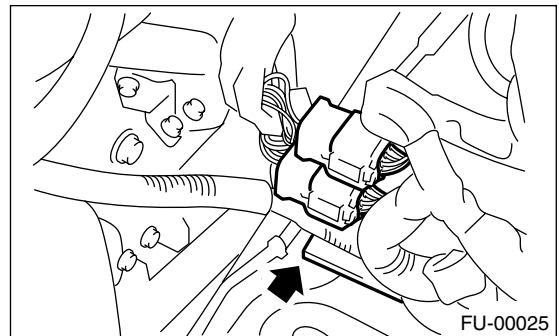

INTAKE MANIFOLD

FUEL INJECTION (FUEL SYSTEMS)

9) Connect the brake booster vacuum hose.

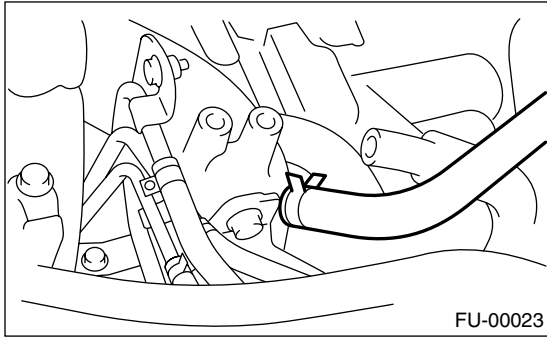

10) Connect the engine coolant hoses to the throttle body.

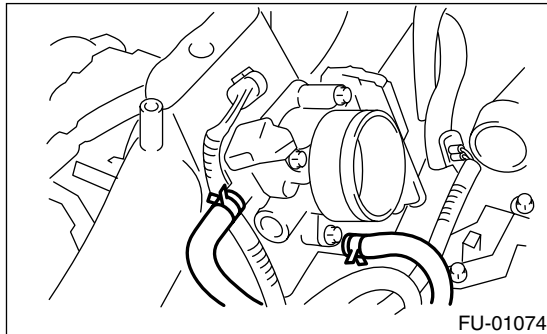

11) Connect the emission hose (A) and connector (B) to the PCV hose assembly.

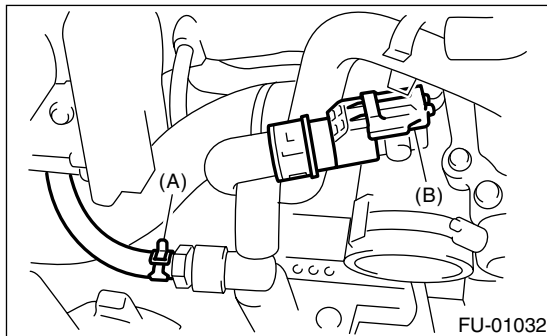

12) Connect the pressure hose to the intake duct.

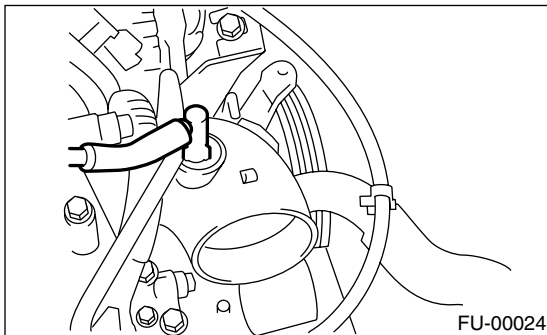

13) Install the power steering pump.

(1) Install the power steering tank on the bracket.

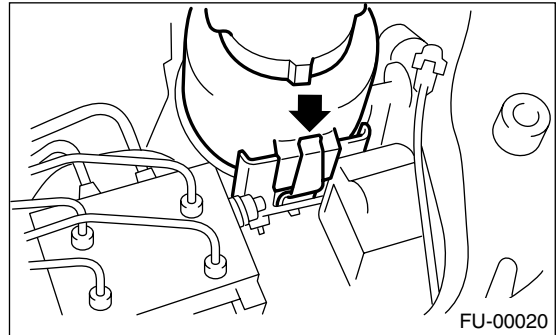

(2) Connect the connector to the power steering pump switch.

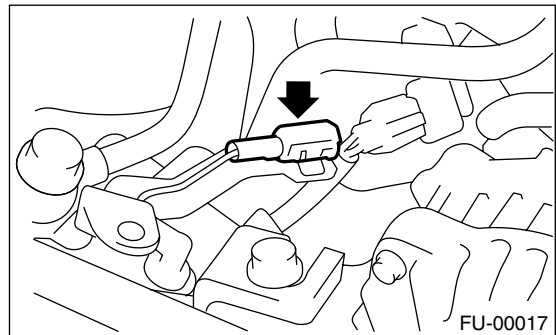

(3) Install the power steering pump, and tighten the bolts.

Tightening torque:
22 N·m (2.2 kgf-m, 15.9 ft-lb)

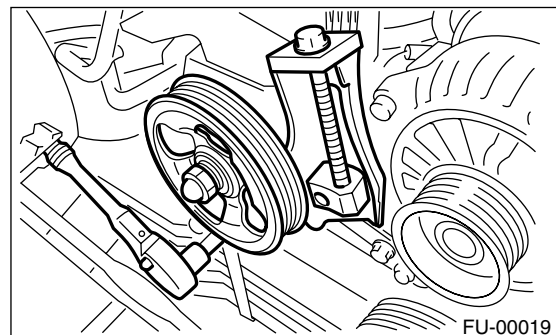

(4) Install the power steering pipe brackets on the intake manifold RH.

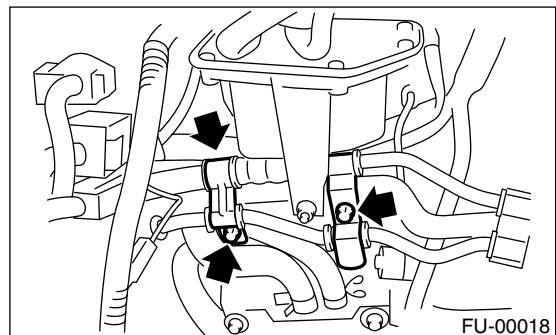

INTAKE MANIFOLD

FUEL INJECTION (FUEL SYSTEMS)

- (5) Install the front side V-belt. <Ref. to ME(STi)-41, INSTALLATION, V-belt.>
- 14) Install the coolant filler tank. <Ref. to CO(H4DOTC)-32, INSTALLATION, Coolant Filler Tank.>
- 15) Install the intercooler. <Ref. to IN(STi)-11, INSTALLATION, Intercooler.>
- 16) Install the air cleaner element.
- 17) Install the air cleaner upper cover and air intake duct as a unit. <Ref. to IN(STi)-8, INSTALLATION, Air Cleaner.>
- 18) Connect the connector to the fuel pump relay.

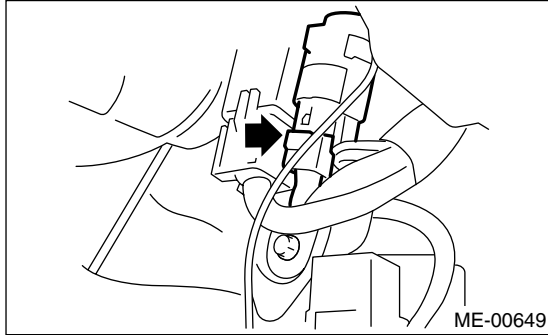

- 19) Connect the battery ground cable to battery.
- 20) Lift up the vehicle.
- 21) Install the under cover.
- 22) Fill the engine coolant. <Ref. to CO(H4DOTC)-17, FILLING OF ENGINE COOLANT, REPLACEMENT, Engine Coolant.>

C: DISASSEMBLY

- 1) Remove the fuel pipe protector RH.

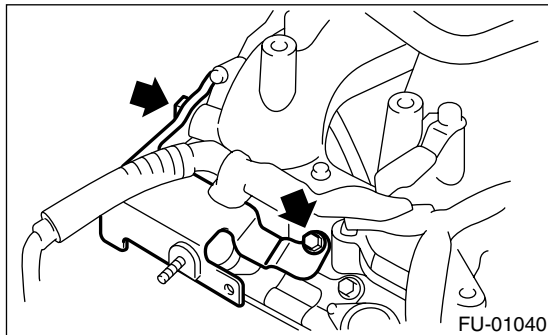

- 2) Remove the engine ground terminal from the intake manifold.

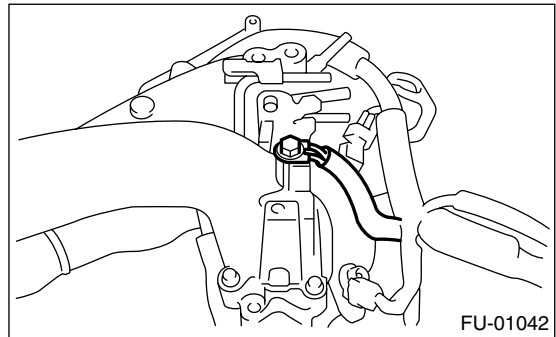
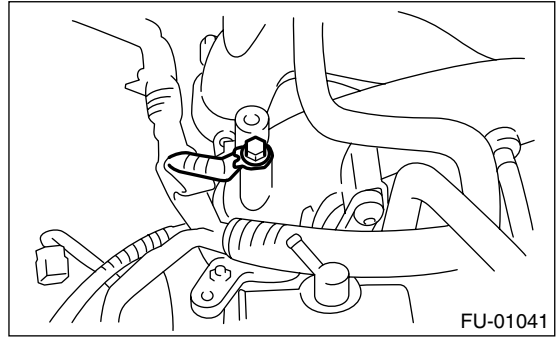

- 3) Disconnect the connector from the throttle position sensor (A) and manifold absolute pressure sensor (B).

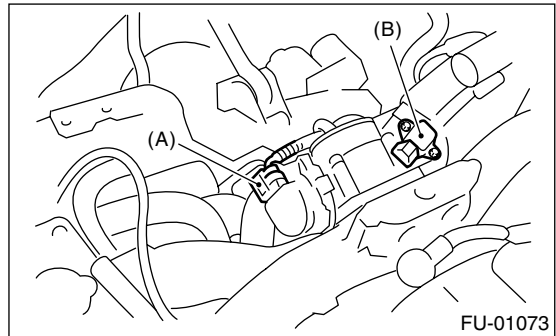

- 4) Remove the throttle body from the intake manifold.

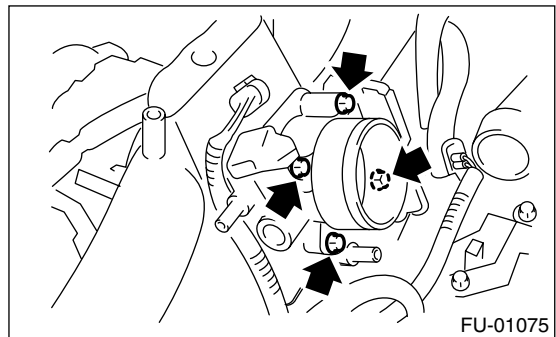

INTAKE MANIFOLD

FUEL INJECTION (FUEL SYSTEMS)

5) Disconnect the connector from the fuel injector.

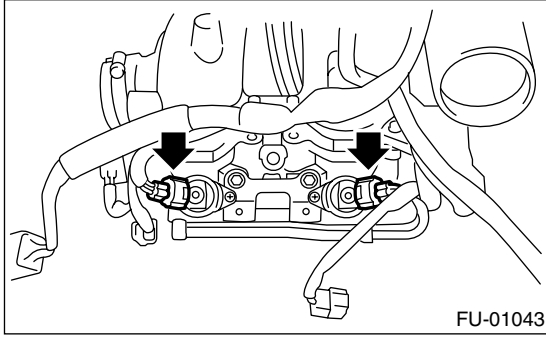

6) Disconnect the connector from the tumble generator valve actuator.

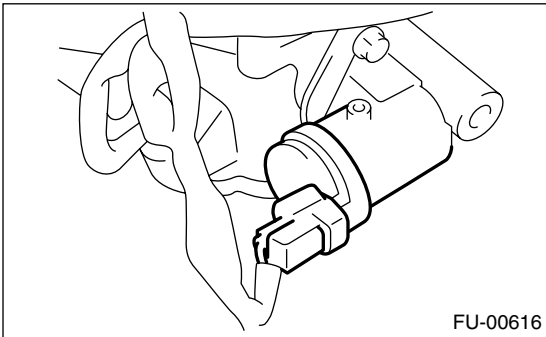

7) Disconnect the connector from the tumble generator valve sensor.

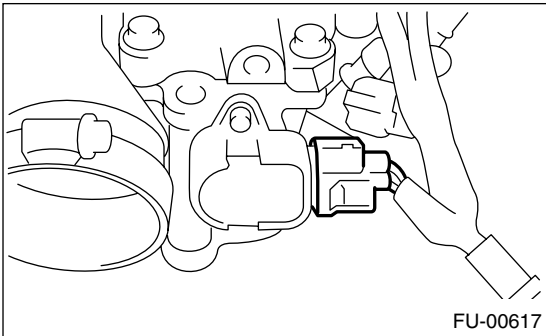

8) Disconnect the connector from the purge control solenoid valve.

9) Remove the purge control solenoid valve.

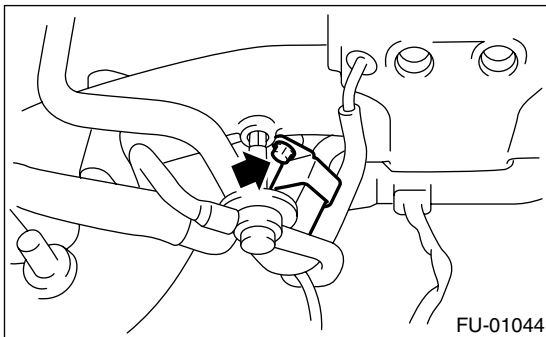

10) Disconnect the evaporation hose and purge valve from the intake manifold.

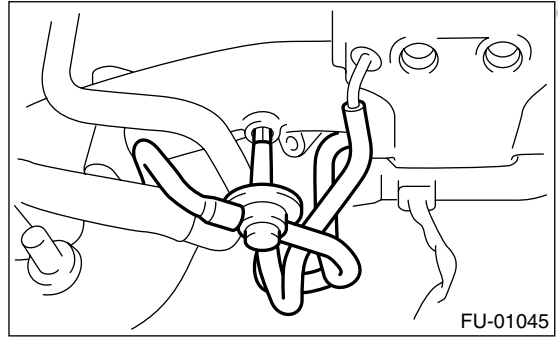

11) Remove the two bolts which hold the fuel pipes on the left side of intake manifold.

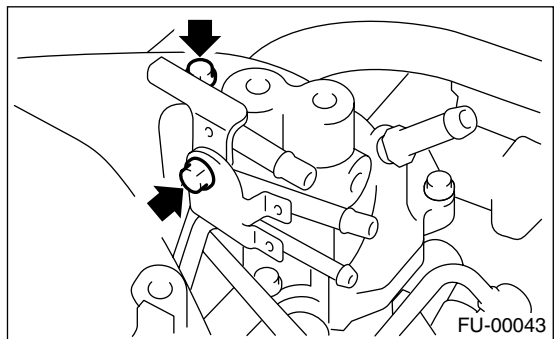

12) Remove the bolt which hold the fuel injector pipe onto intake manifold.

• LH SIDE

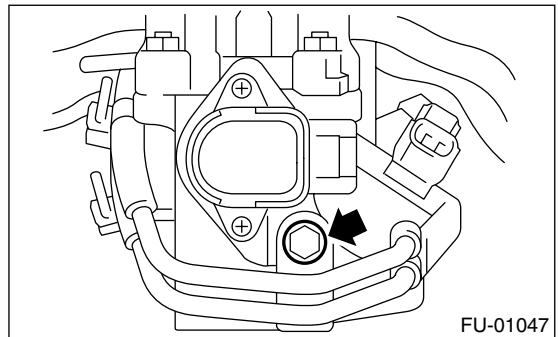
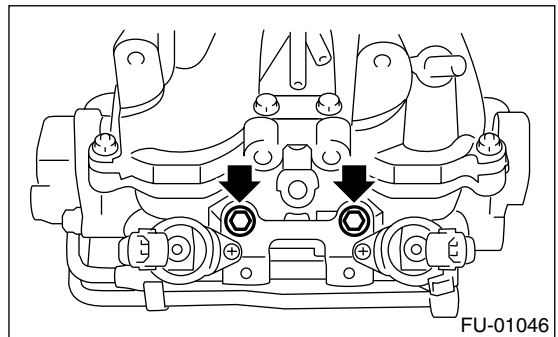

INTAKE MANIFOLD

FUEL INJECTION (FUEL SYSTEMS)

- RH SIDE

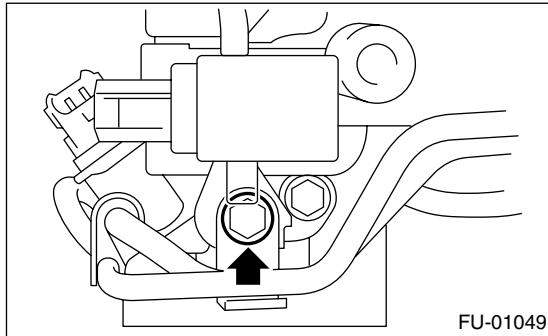
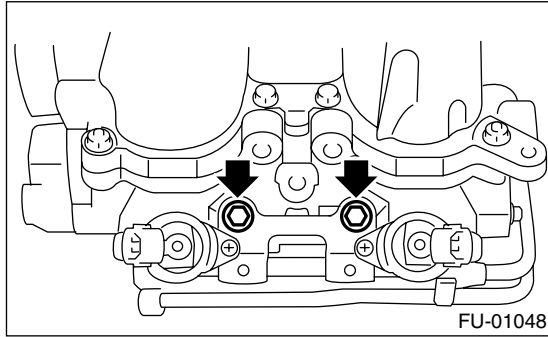

13) Remove the harness bracket which holds the engine harness onto intake manifold.

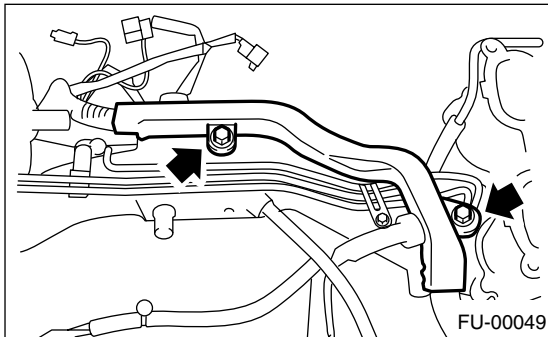

14) Remove the engine harness from the intake manifold.

15) Loosen the clamp which holds the front left side fuel hose to injector pipe, and then remove the pipe from clamp.

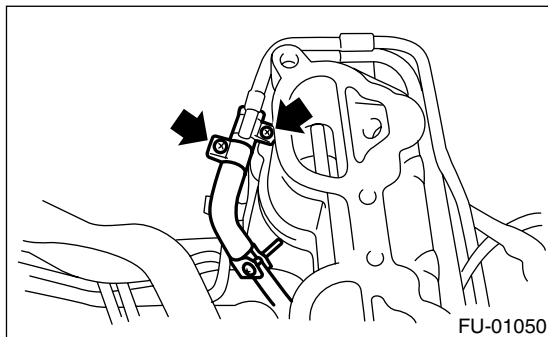

16) Loosen the clamp which holds the right side fuel hose to injector pipe, and then remove the pipe from clamp.

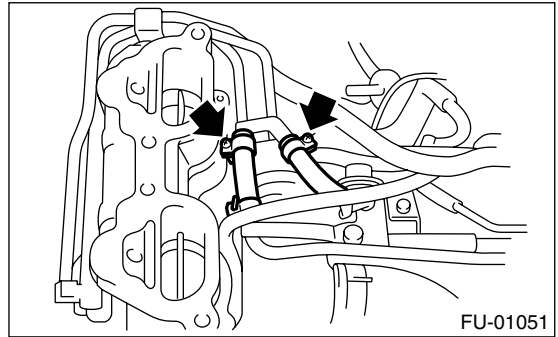

17) Remove the bolts which install the fuel pipe on intake manifold.

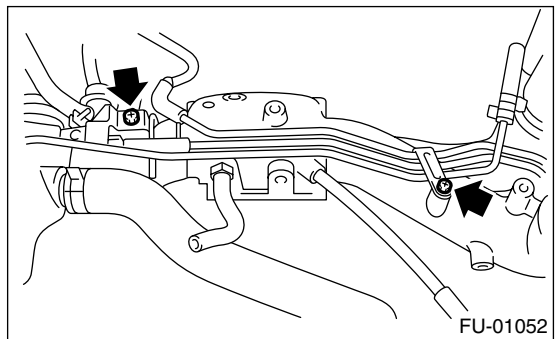

18) Remove the fuel pipe assembly and pressure regulator from the intake manifold.

19) Remove the intake duct from the intake manifold.

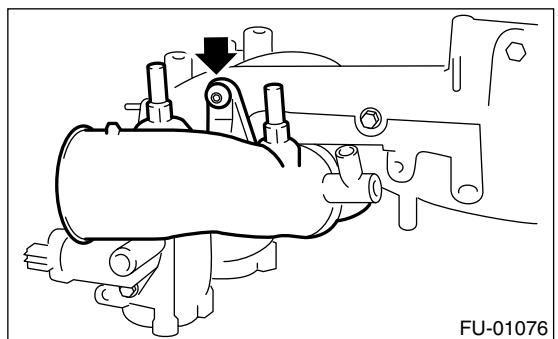

20) Remove the tumble generator valve assembly from the intake manifold.

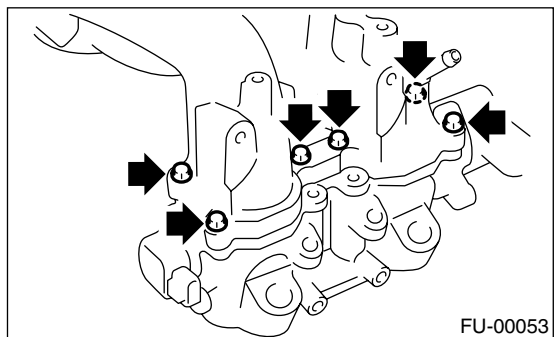

INTAKE MANIFOLD

FUEL INJECTION (FUEL SYSTEMS)

D: ASSEMBLY

NOTE:

Replace the gasket with a new one.

1) Install the tumble generator valve assembly to the intake manifold.

Tightening torque:

8.25 N·m (0.84 kgf-m, 6.1 ft-lb)

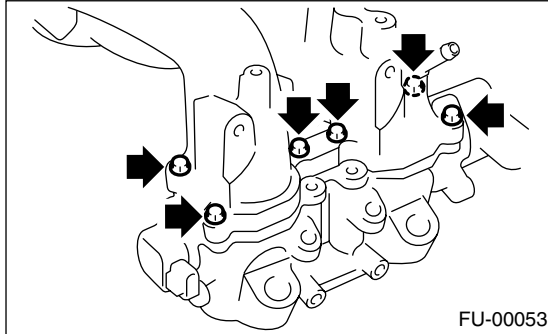

2) Install the air intake duct to the intake manifold.

Tightening torque:

19 N·m (1.94 kgf-m, 13.7 ft-lb)

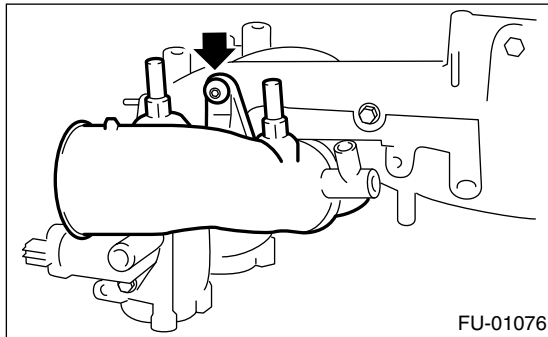

3) Install the fuel pipe assembly and pressure regulator to the intake manifold.

Tightening torque:

4.9 N·m (0.5 kgf-m, 3.6 ft-lb)

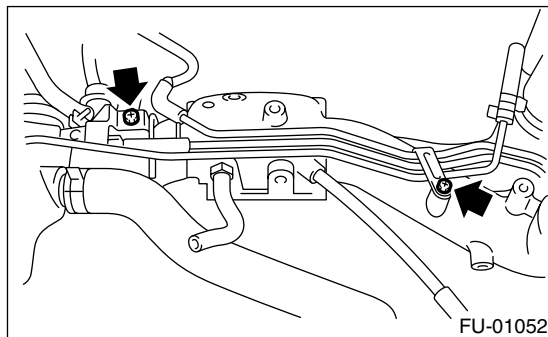

4) Install the fuel injector pipe LH.

5) Connect the left side fuel hose to injector pipe, and tighten the clamp screw.

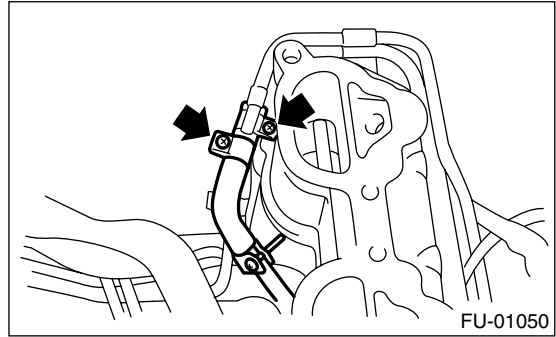

6) Install the fuel injector pipe RH.

7) Connect the right side fuel hose to injector pipe, and tighten the clamp screw.

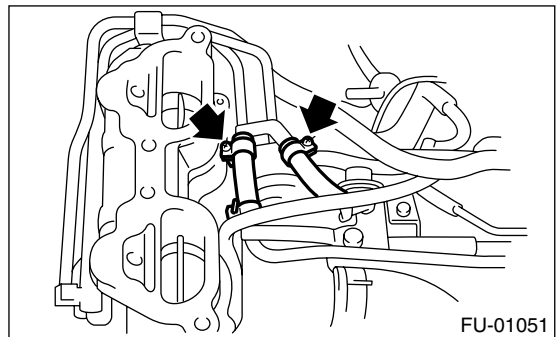

8) Install the engine harness to the intake manifold.

9) Install the harness bracket which holds the engine harness onto intake manifold.

Tightening torque:

19 N·m (1.94 kgf-m, 13.7 ft-lb)

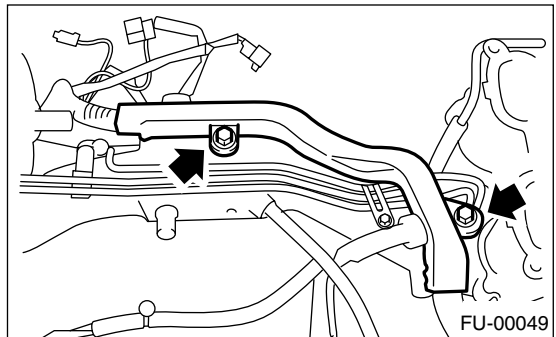

INTAKE MANIFOLD

FUEL INJECTION (FUEL SYSTEMS)

10) Tighten the bolts which install the fuel injector pipe onto intake manifold.

Tightening torque:

19 N·m (1.94 kgf·m, 13.7 ft·lb)

• LH SIDE

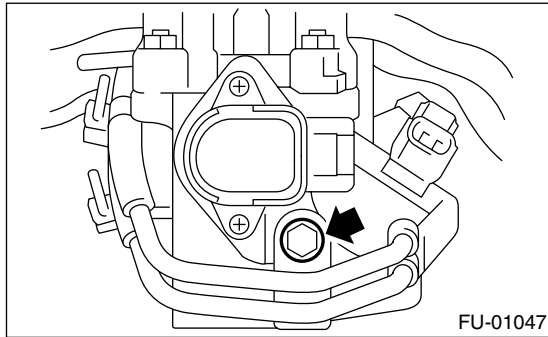
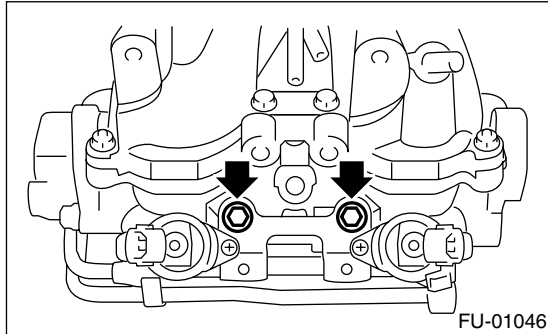

• RH SIDE

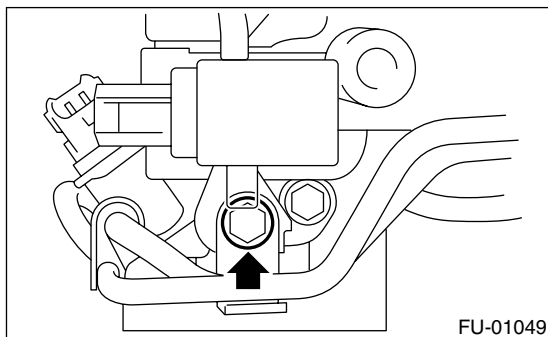
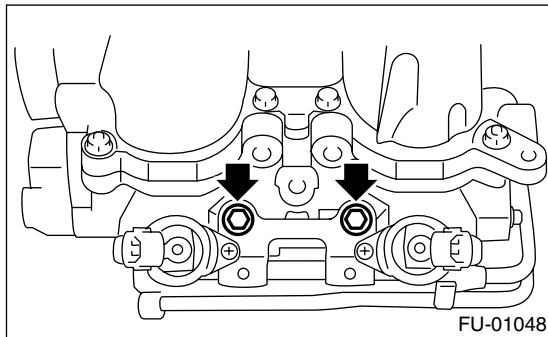

11) Tighten the two bolts which install the fuel pipes on the left side of intake manifold.

Tightening torque:

4.9 N·m (0.5 kgf·m, 3.6 ft·lb)

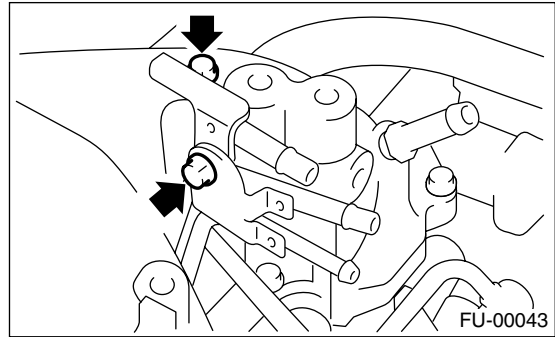

12) Connect the evaporation hoses to the purge valve.

NOTE:

Connect the evaporation hoses as shown in the figure.

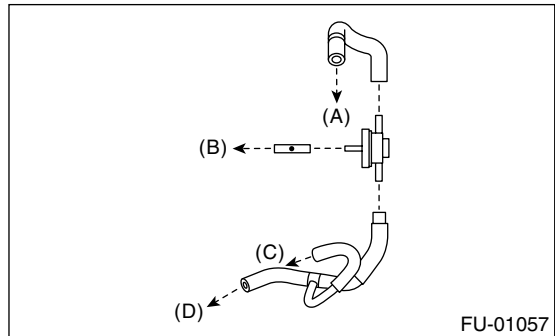

- (A) To intake duct
- (B) To intake manifold
- (C) To purge control solenoid valve
- (D) To fuel pipe ASSY

13) Connect the evaporation hose and purge valve to the intake manifold.

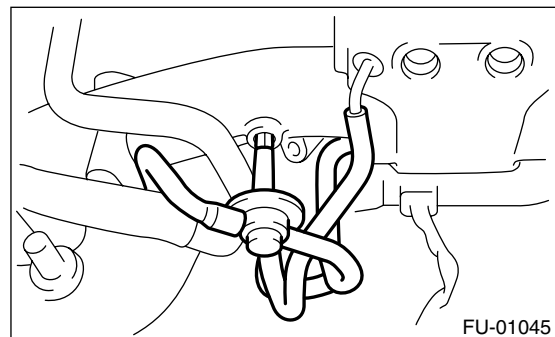

INTAKE MANIFOLD

FUEL INJECTION (FUEL SYSTEMS)

14) Install the purge control solenoid valve.

Tightening torque:

16 N·m (1.6 kgf·m, 11.8 ft·lb)

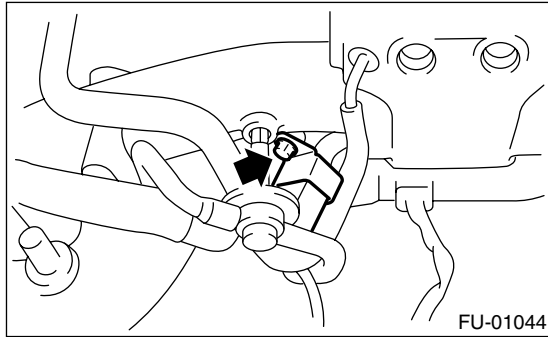

15) Connect the hoses to the purge control solenoid valve.

NOTE:

Connect the evaporation hoses as shown in the figure.

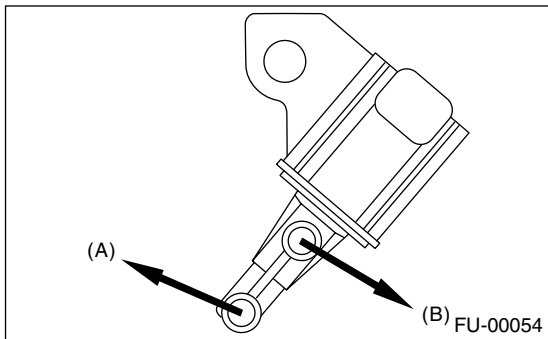

(A) To purge valve

(B) To intake manifold

16) Connect the connector to the purge control solenoid valve.

17) Connect the connector to the tumble generator valve sensor.

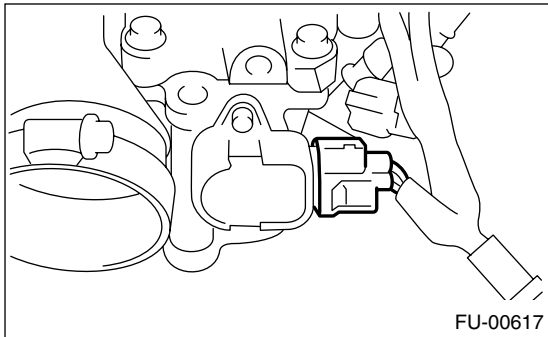

18) Connect the connector to the tumble generator valve actuator.

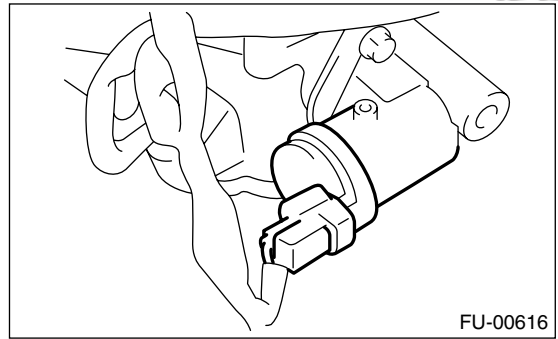

19) Connect the connector to the fuel injector.

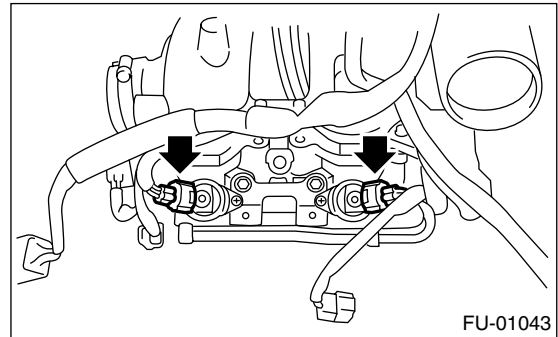

20) Install the throttle body to the intake manifold.

NOTE:

Replace the gasket with a new one.

Tightening torque:

8 N·m (0.8 kgf·m, 5.8 ft·lb)

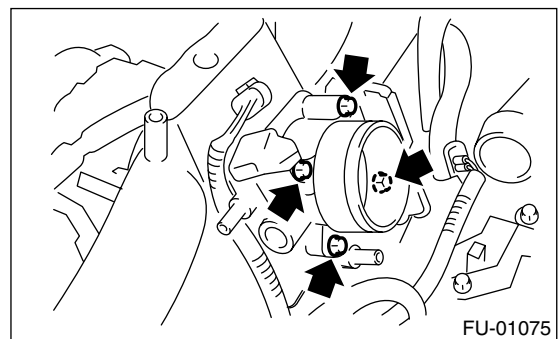

INTAKE MANIFOLD

FUEL INJECTION (FUEL SYSTEMS)

21) Connect the connector to the throttle position sensor (A) and manifold absolute pressure sensor (B).

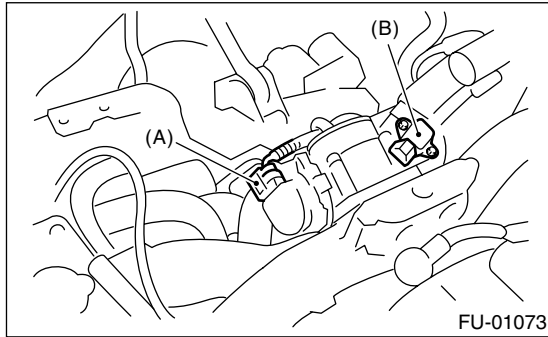

22) Install the engine ground terminal to the intake manifold.

Tightening torque:

19 N·m (1.94 kgf-m, 13.7 ft-lb)

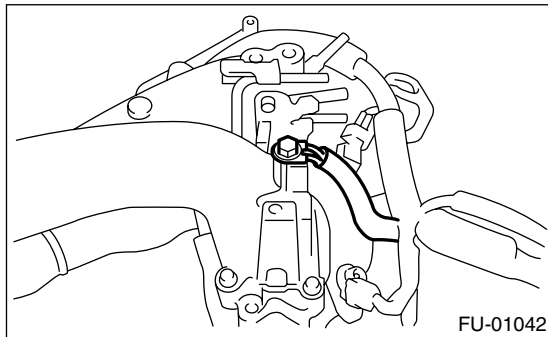
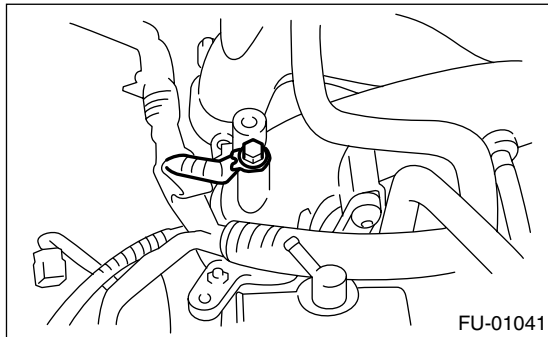

23) Install the fuel pipe protector RH.

Tightening torque:

19 N·m (1.94 kgf-m, 13.7 ft-lb)

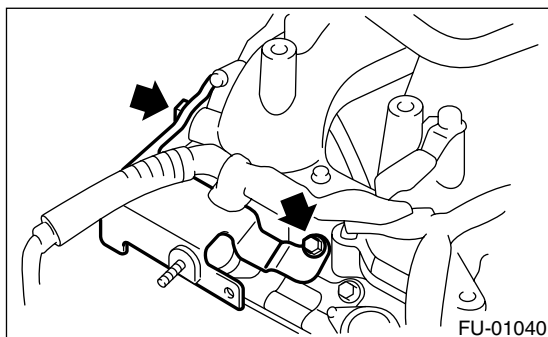

E: INSPECTION

Make sure the fuel pipe and fuel hoses are not cracked and the connections are tightened.

ENGINE COOLANT TEMPERATURE SENSOR

FUEL INJECTION (FUEL SYSTEMS)

4. Engine Coolant Temperature Sensor

A: REMOVAL

1) Disconnect the ground cable from battery.

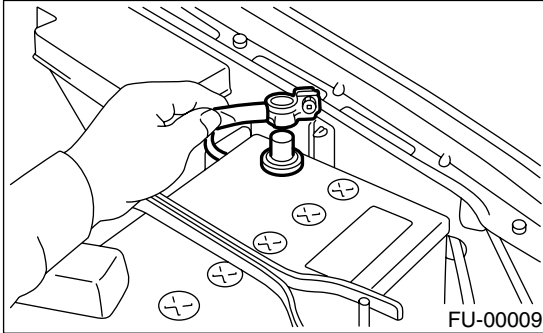

2) Remove the generator. <Ref. to SC(H4SO)-14, REMOVAL, Generator.>

3) Drain the engine coolant. <Ref. to CO(H4DOTC)-17, DRAINING OF ENGINE COOLANT, REPLACEMENT, Engine Coolant.>

4) Disconnect the connector from the engine coolant temperature sensor.

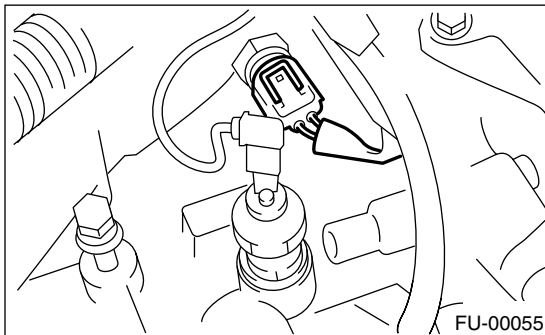

5) Remove the engine coolant temperature sensor.

B: INSTALLATION

Install in the reverse order of removal.

Tightening torque:

18 N·m (1.8 kgf·m, 13.3 ft·lb)

CRANKSHAFT POSITION SENSOR

FUEL INJECTION (FUEL SYSTEMS)

5. Crankshaft Position Sensor

A: REMOVAL

1) Disconnect the ground cable from battery.

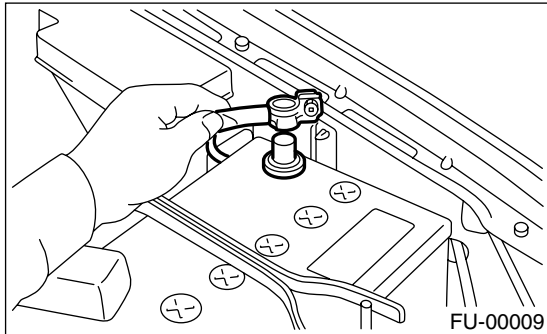

2) Remove the bolt which installs the crankshaft position sensor to cylinder block.

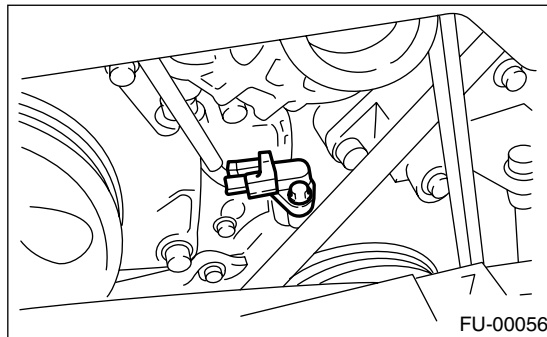

3) Remove the crankshaft position sensor, and disconnect the connector from it.

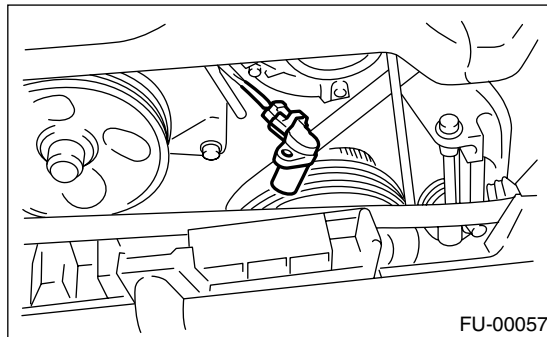

B: INSTALLATION

Install in the reverse order of removal.

Tightening torque:

T: 6.4 N·m (0.65 kgf-m, 4.7 ft-lb)

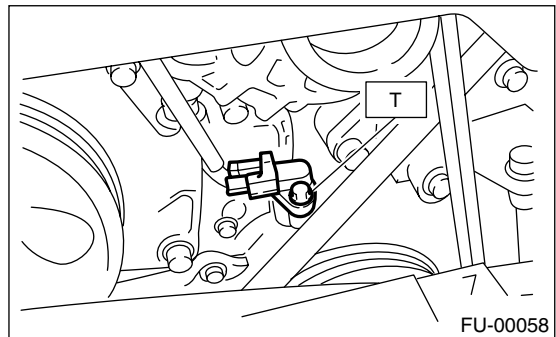

CAMSHAFT POSITION SENSOR

FUEL INJECTION (FUEL SYSTEMS)

6. Camshaft Position Sensor

A: REMOVAL

1) Disconnect the ground cable from battery.

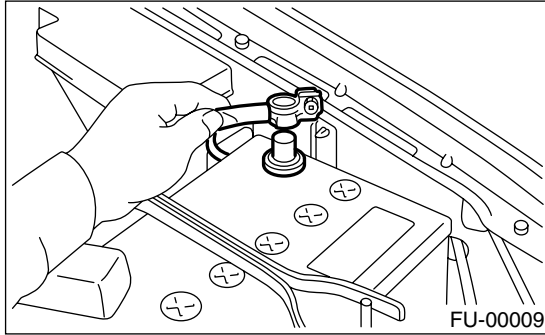

2) Disconnect the connector from the camshaft position sensor RH.

3) Remove the camshaft position sensor RH from the backside of cylinder head.

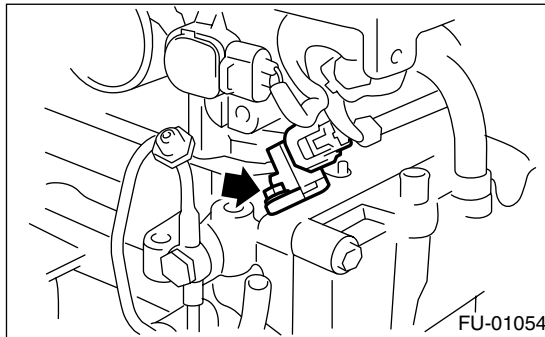

4) Remove the camshaft position sensor LH same as RH side.

B: INSTALLATION

Install in the reverse order of removal.

Tightening torque:

T: 6.4 N·m (0.65 kgf-m, 4.7 ft-lb)

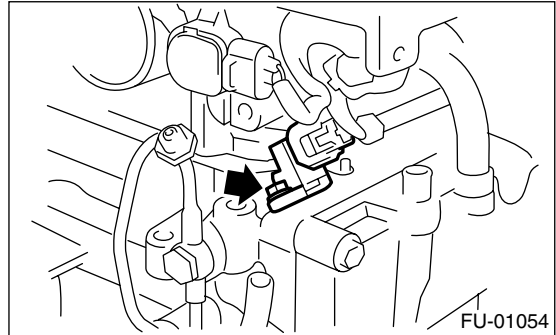

7. Knock Sensor

A: REMOVAL

1) Disconnect the ground cable from battery.

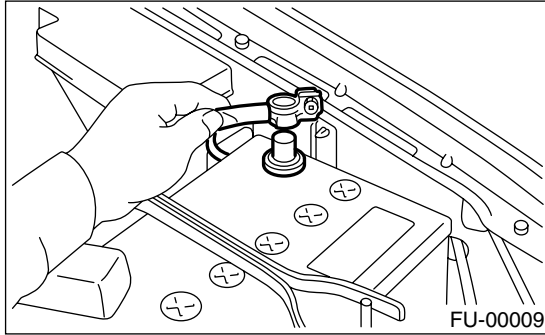

2) Remove the intercooler. <Ref. to IN(STi)-11, REMOVAL, Intercooler.>

3) Disconnect the knock sensor connector.

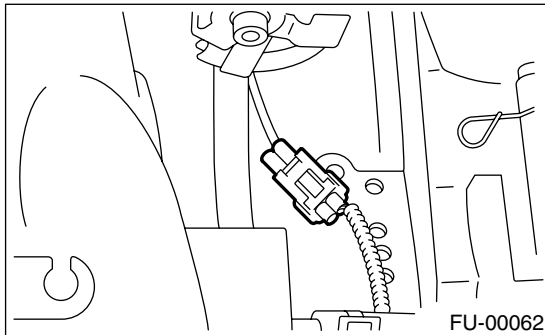

4) Remove the knock sensor from the cylinder block.

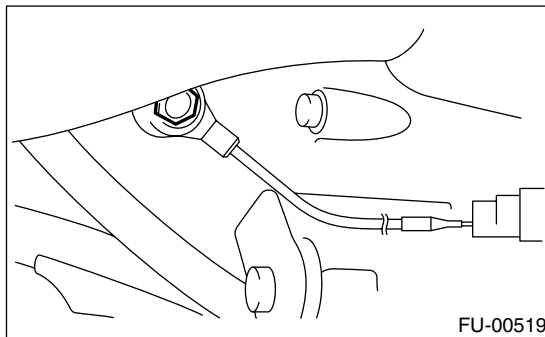

B: INSTALLATION

1) Install the knock sensor to the cylinder block.

Tightening torque:

24 N·m (2.4 kgf-m, 17.4 ft-lb)

NOTE:

Extraction area of the knock sensor cord must be positioned at a 60° angle relative to the engine rear.

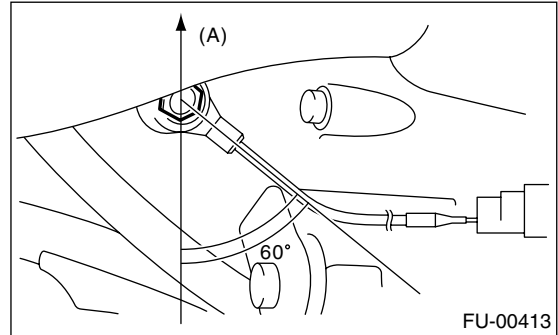

(A) Front side

2) Connect the knock sensor connector.

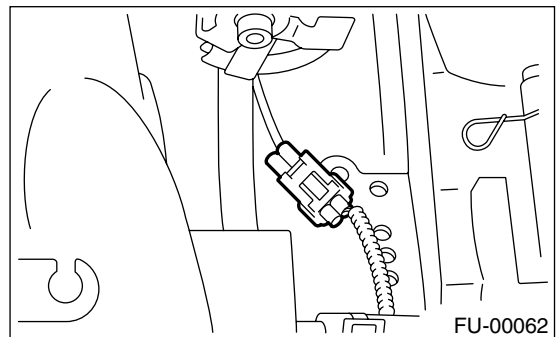

3) Install the intercooler. <Ref. to IN(STi)-11, INSTALLATION, Intercooler.>

4) Connect the battery ground cable to battery.

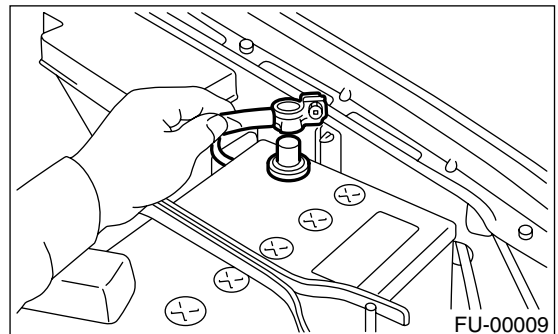

MASS AIR FLOW AND INTAKE AIR TEMPERATURE SENSOR

FUEL INJECTION (FUEL SYSTEMS)

8. Mass Air Flow and Intake Air Temperature Sensor

A: REMOVAL

1) Disconnect the ground cable from battery.

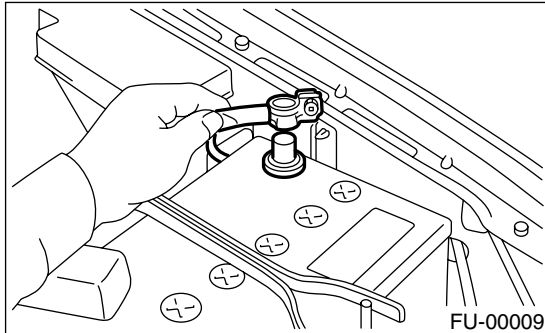

2) Disconnect the connector from mass air flow and intake air temperature sensor.

3) Remove the mass air flow and intake air temperature sensor.

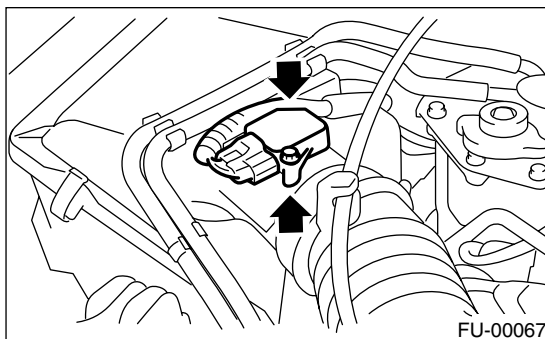

B: INSTALLATION

Install in the reverse order of removal.

Tightening torque:

1.7 N·m (0.17 kgf-m, 1.3 ft-lb)

MANIFOLD ABSOLUTE PRESSURE SENSOR

FUEL INJECTION (FUEL SYSTEMS)

9. Manifold Absolute Pressure Sensor

A: REMOVAL

- 1) Disconnect the ground cable from battery.

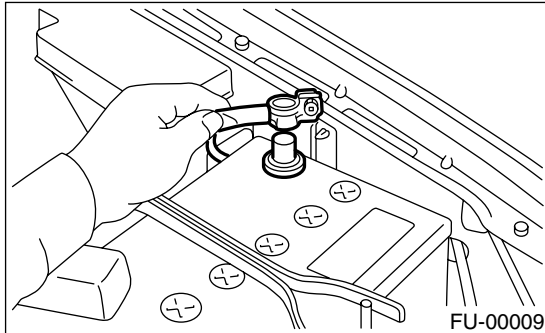

- 2) Disconnect the connectors from manifold absolute pressure sensor.

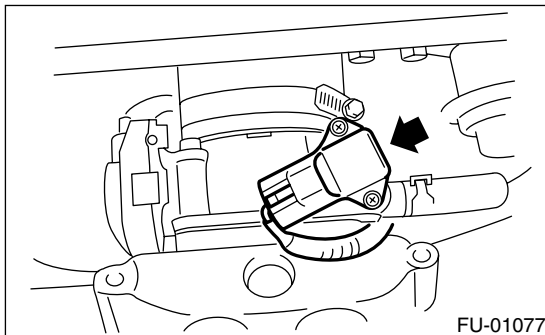

- 3) Remove the manifold absolute pressure sensor from the throttle body.

B: INSTALLATION

Install in the reverse order of removal.

NOTE:

Replace the O-rings for the manifold absolute pressure sensor with new ones.

Tightening torque:

1.6 N-m (0.16 kgf-m, 1.2 ft-lb)

FUEL INJECTOR

FUEL INJECTION (FUEL SYSTEMS)

10. Fuel Injector

A: REMOVAL

1. RH SIDE

- 1) Release the fuel pressure. <Ref. to FU(STi)-45, RELEASING OF FUEL PRESSURE, OPERATION, Fuel.>
- 2) Open the fuel filler flap lid and remove the fuel filler cap.
- 3) Disconnect the ground cable from battery.

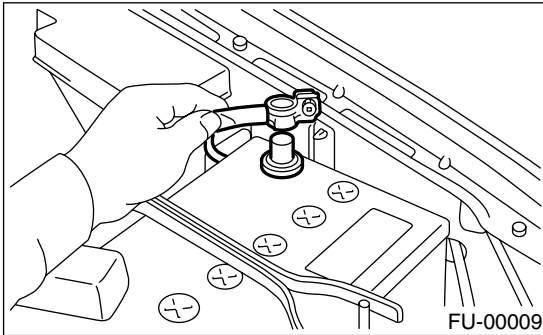

- 4) Remove the fuel pipe protector RH.

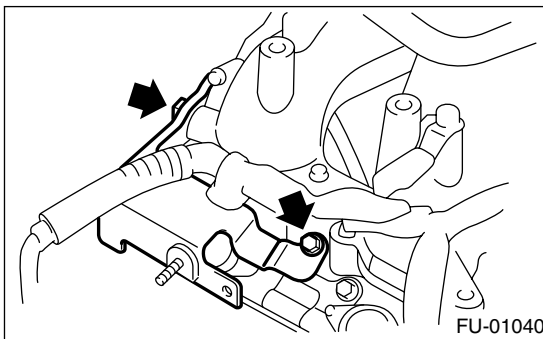

- 5) Disconnect the connector from the fuel injector.
- 6) Remove the screw and remove the fuel injector.

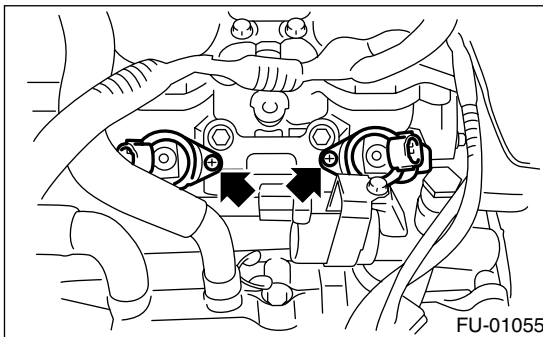

2. LH SIDE

- 1) Release the fuel pressure. <Ref. to FU(STi)-45, RELEASING OF FUEL PRESSURE, OPERATION, Fuel.>
- 2) Open the fuel filler flap lid and remove the fuel filler cap.
- 3) Disconnect the ground cable from battery.

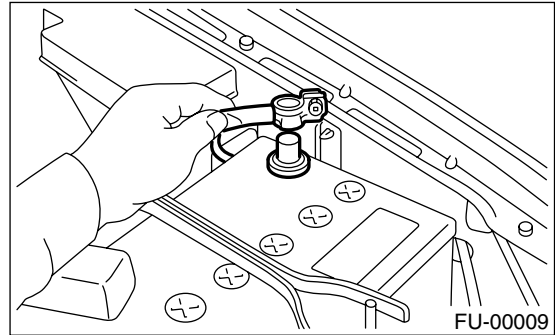

- 4) Remove the intake manifold. <Ref. to FU(STi)-14, REMOVAL, Intake Manifold.>
- 5) Disconnect the connector from the fuel injector.
- 6) Remove the screw and remove the fuel injector.

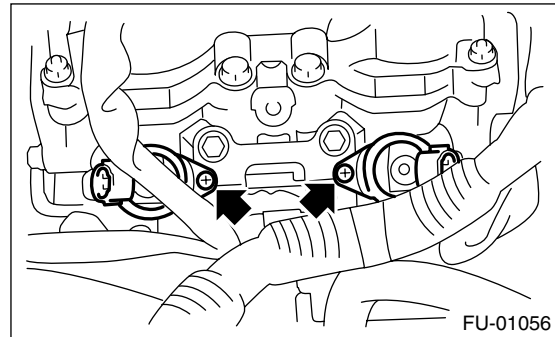

B: INSTALLATION

1. RH SIDE

Install in the reverse order of removal.

NOTE:

Replace the O-rings with new ones.

2. LH SIDE

Install in the reverse order of removal.

NOTE:

Replace the O-rings with new ones.

TUMBLE GENERATOR VALVE ASSEMBLY

FUEL INJECTION (FUEL SYSTEMS)

11. Tumble Generator Valve Assembly

A: REMOVAL

- 1) Release the fuel pressure. <Ref. to FU(STi)-45, RELEASING OF FUEL PRESSURE, OPERATION, Fuel.>
- 2) Open the fuel filler lid and remove the fuel filler cap.
- 3) Disconnect the ground cable from battery.

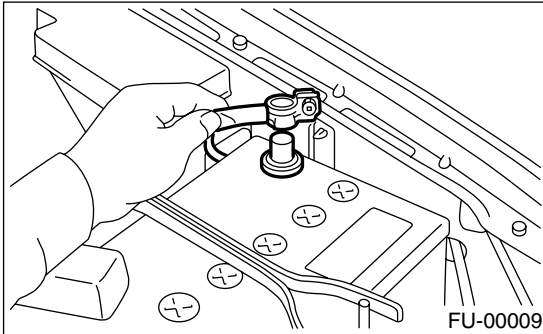

- 4) Remove the intake manifold. <Ref. to FU(STi)-14, REMOVAL, Intake Manifold.>
- 5) Disconnect the connector from the tumble generator valve sensor.

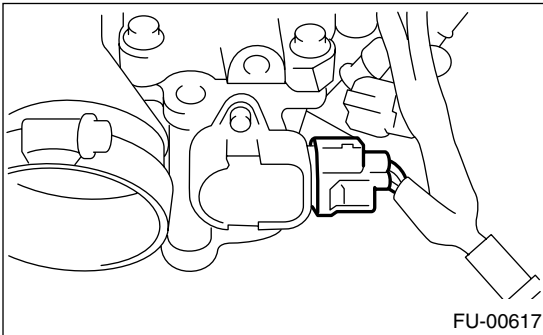

- 6) Disconnect the connector from the tumble generator valve actuator.

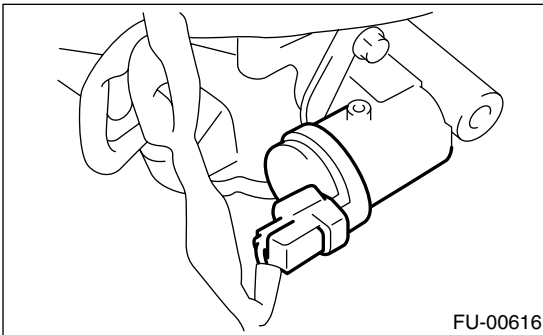

- 7) Remove the fuel injector. <Ref. to FU(STi)-32, REMOVAL, Fuel Injector.>

- 8) Remove the tumble generator valve body from the intake manifold.

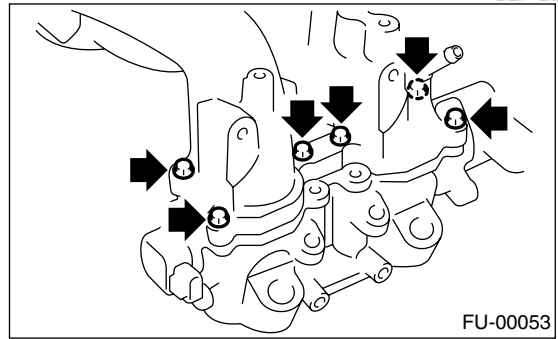

B: INSTALLATION

Install in the reverse order of removal.

NOTE:

Always use new gaskets.

Tightening torque:

8.25 N·m (0.84 kgf·m, 6.1 ft·lb)

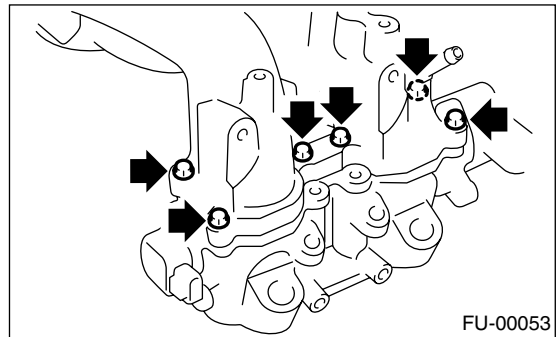

TUMBLE GENERATOR VALVE ACTUATOR

FUEL INJECTION (FUEL SYSTEMS)

12. Tumble Generator Valve Actuator

A: REMOVAL

1. RH SIDE

- 1) Release the fuel pressure. <Ref. to FU(STi)-45, RELEASING OF FUEL PRESSURE, OPERATION, Fuel.>
- 2) Open the fuel filler lid and remove the fuel filler cap.
- 3) Disconnect the ground cable from battery.

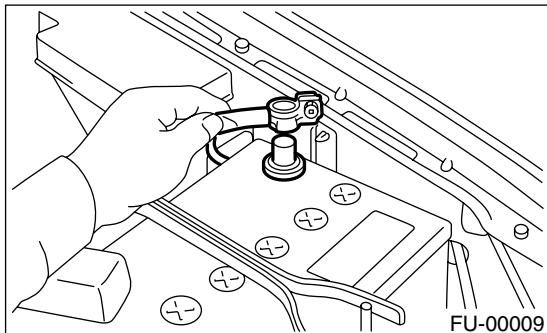

- 4) Remove the intake manifold. <Ref. to FU(STi)-14, REMOVAL, Intake Manifold.>
- 5) Disconnect the connector from tumble generator valve actuator RH.
- 6) Remove the tumble generator valve actuator RH.

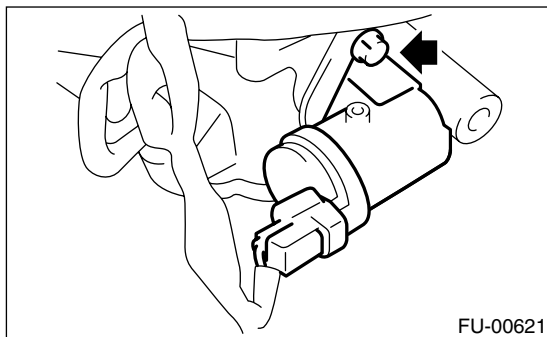

2. LH SIDE

- 1) Release the fuel pressure. <Ref. to FU(STi)-45, RELEASING OF FUEL PRESSURE, OPERATION, Fuel.>
- 2) Open the fuel filler lid and remove the fuel filler cap.
- 3) Disconnect the ground cable from battery.

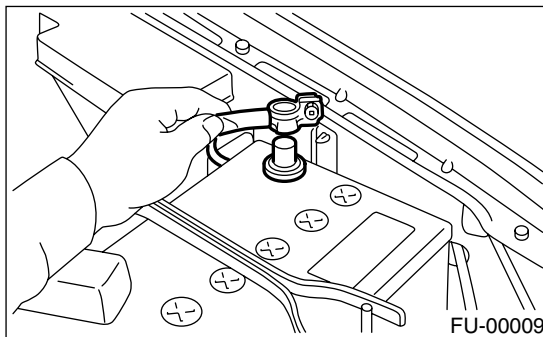

- 4) Disconnect the connector from tumble generator valve actuator LH.
- 5) Remove the tumble generator valve actuator LH.

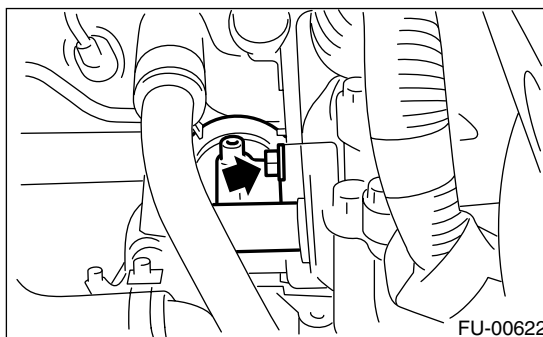

B: INSTALLATION

1. RH SIDE

Install in the reverse order of removal.

2. LH SIDE

Install in the reverse order of removal.

WASTEGATE CONTROL SOLENOID VALVE

FUEL INJECTION (FUEL SYSTEMS)

13. Wastegate Control Solenoid Valve

A: REMOVAL

1) Disconnect the ground cable from battery.

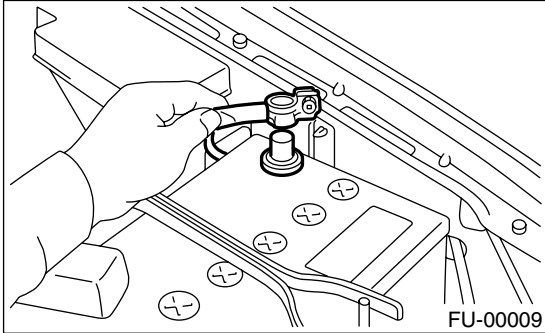

2) Disconnect the engine harness connector (A) from bracket.

3) Disconnect the connector (B) from wastegate control solenoid valve.

4) Remove the bracket from body.

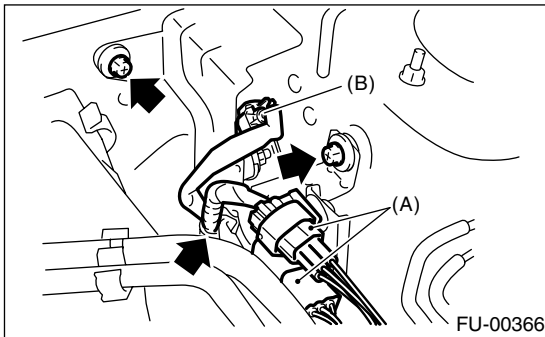

5) Disconnect the pressure hoses (C) from wastegate control solenoid valve.

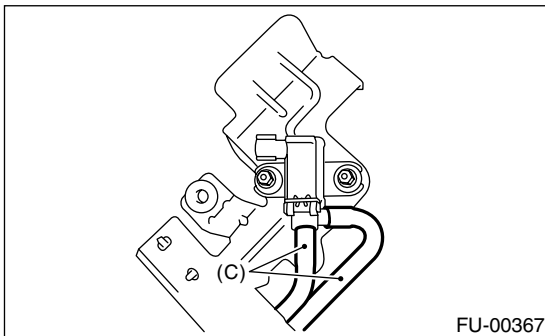

6) Remove the wastegate control solenoid valve from bracket.

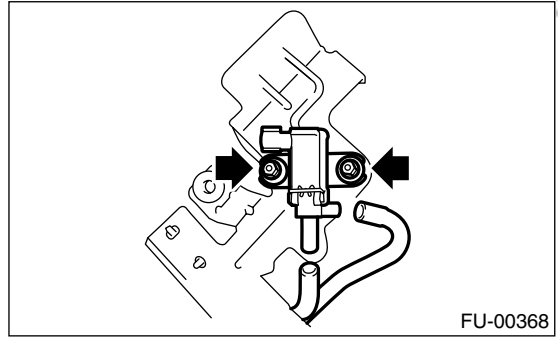

B: INSTALLATION

Install in the reverse order of removal.

Tightening torque:

6.4 N·m (0.65 kgf·m, 4.7 ft·lb)

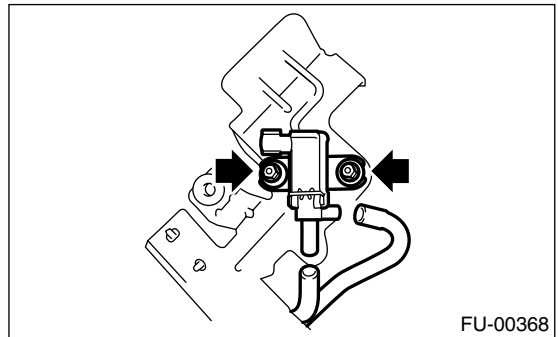

FRONT OXYGEN (A/F) SENSOR

FUEL INJECTION (FUEL SYSTEMS)

14. Front Oxygen (A/F) Sensor

A: REMOVAL

1) Disconnect the ground cable from battery.

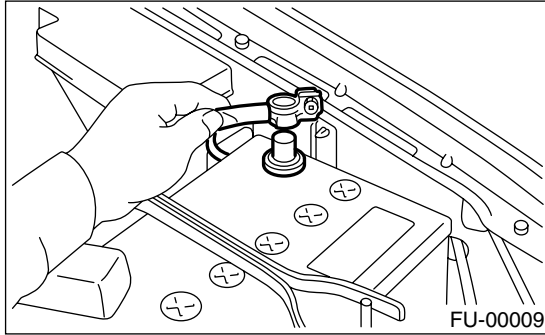

2) Disconnect the connector from the front oxygen (A/F) sensor.

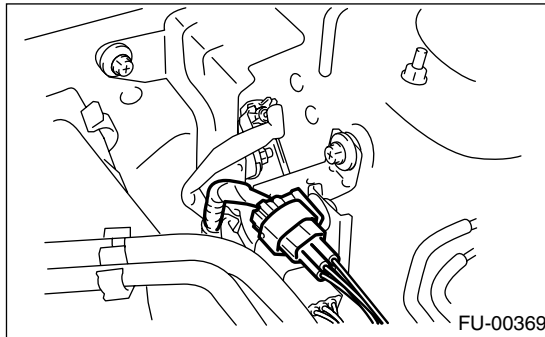

3) Disconnect the engine harness fixed by clip (A) from the bracket (B).

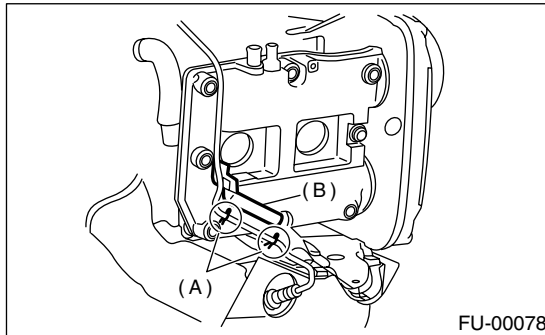

4) Remove the front right side wheel.

5) Lift-up the vehicle.

6) Remove the service hole cover.

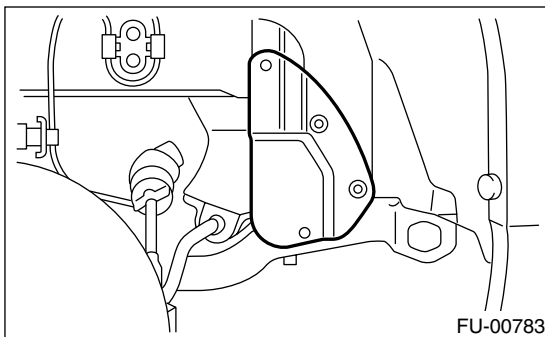

7) Apply SUBARU CRC or its equivalent to the threaded portion of front oxygen (A/F) sensor, and leave it for one minute or more.

SUBARU CRC (Part No. 004301003)

8) Remove the front oxygen (A/F) sensor.

CAUTION:

When removing the oxygen (A/F) sensor, wait until exhaust pipe cools; otherwise, it will damage exhaust pipe.

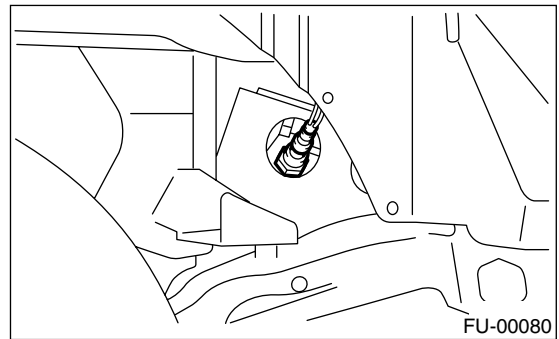

FRONT OXYGEN (A/F) SENSOR

FUEL INJECTION (FUEL SYSTEMS)

B: INSTALLATION

1) Before installing front oxygen (A/F) sensor, apply anti-seize compound only to the threaded portion of front oxygen (A/F) sensor to make the next removal easier.

Anti-seize compound:
SS-30 by JET LUBE

CAUTION:
Never apply anti-seize compound to protector of front oxygen (A/F) sensor.

2) Install the front oxygen (A/F) sensor.

Tightening torque:
30 N-m (3.1 kgf-m, 22.1 ft-lb)

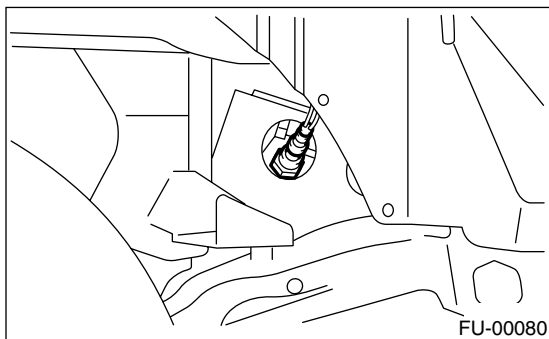

3) Install the service hole cover.

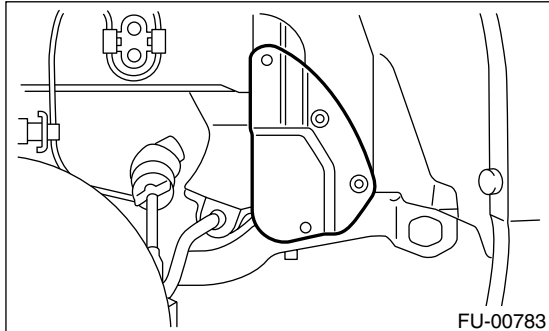

4) Lower the vehicle.

5) Install the front right side wheel.

6) Connect the engine harness to the bracket (B) using clips (A).

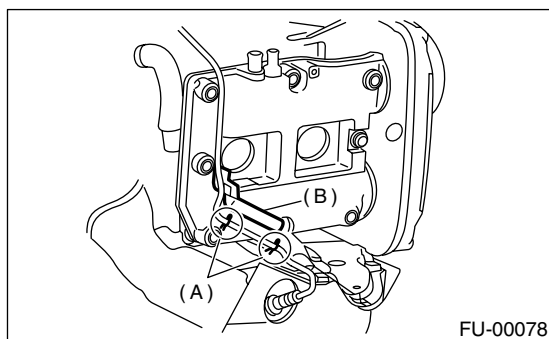

7) Connect the connector of front oxygen (A/F) sensor.

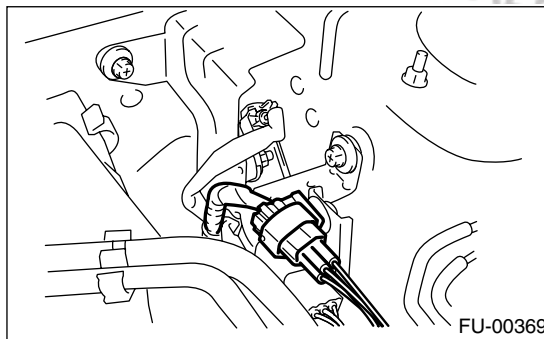

8) Connect the battery ground cable to battery.

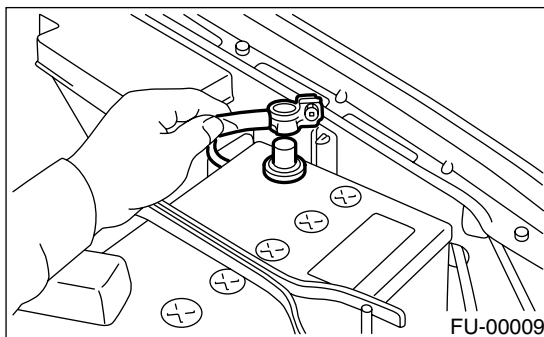

15. Rear Oxygen Sensor

A: REMOVAL

- 1) Disconnect the ground cable from battery.

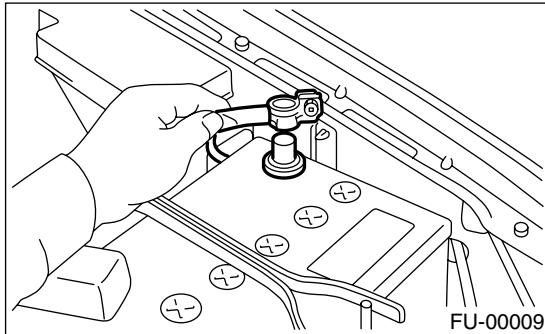

- 2) Lift-up the vehicle.
- 3) Disconnect the connector from the rear oxygen sensor.

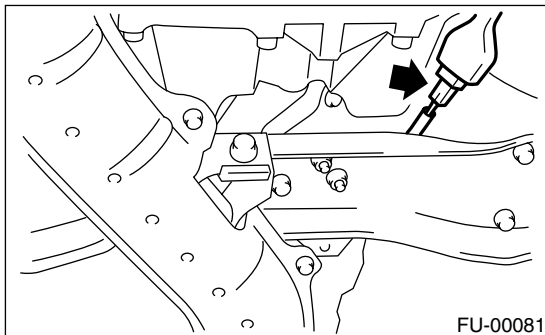

- 4) Remove the clip by pulling out from the upper side of crossmember.

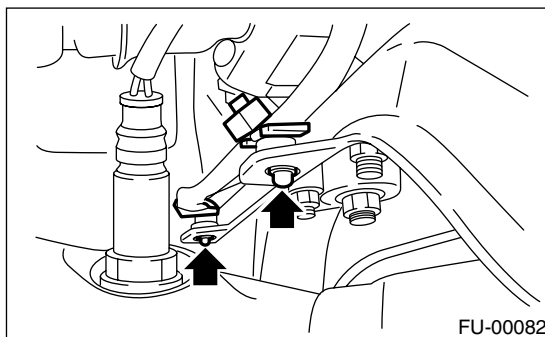

- 5) Apply SUBARU CRC or its equivalent to the threaded portion of rear oxygen sensor, and leave it for one minute or more.

SUBARU CRC (Part No. 004301003)

- 6) Remove the rear oxygen sensor.

CAUTION:

When removing the oxygen sensor, wait until exhaust pipe cools; otherwise, it will damage exhaust pipe.

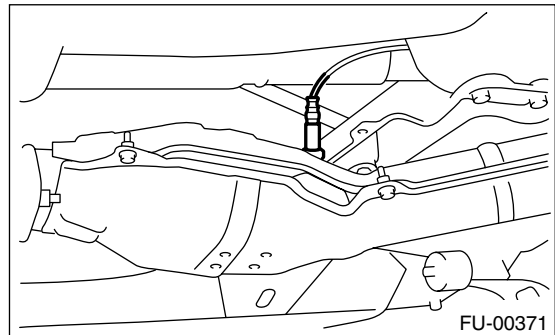

B: INSTALLATION

- 1) Before installing rear oxygen sensor, apply anti-seize compound only to the threaded portion of rear oxygen sensor to make the next removal easier.

CAUTION:

Never apply anti-seize compound to protector of rear oxygen sensor.

**Anti-seize compound:
SS-30 by JET LUBE**

- 2) Install the rear oxygen sensor.

Tightening torque:

21 N·m (2.1 kgf-m, 15.2 ft-lb)

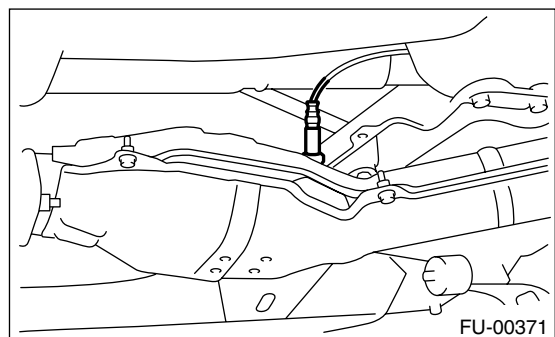

- 3) Connect the connector to the rear oxygen sensor.

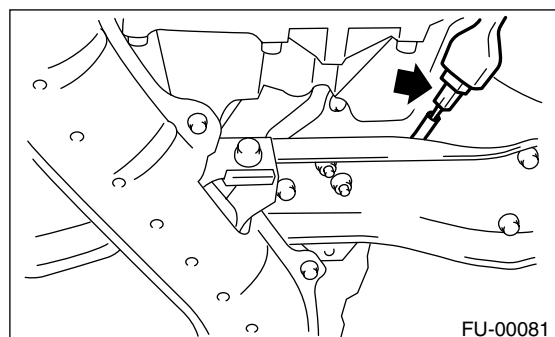

REAR OXYGEN SENSOR

FUEL INJECTION (FUEL SYSTEMS)

4) Connect the clip to the crossmember.

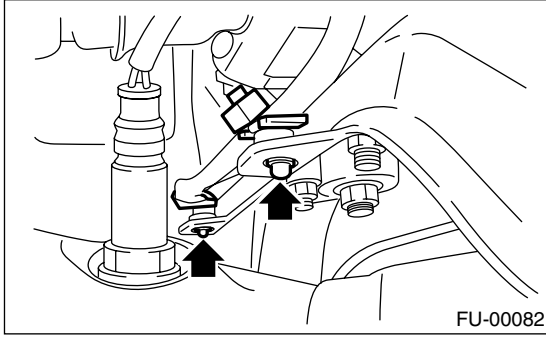

5) Lower the vehicle.

6) Connect the battery ground cable to battery.

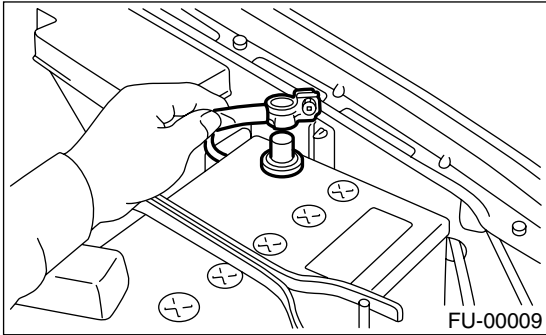

16.Engine Control Module (ECM)

A: REMOVAL

1) Disconnect the ground cable from battery.

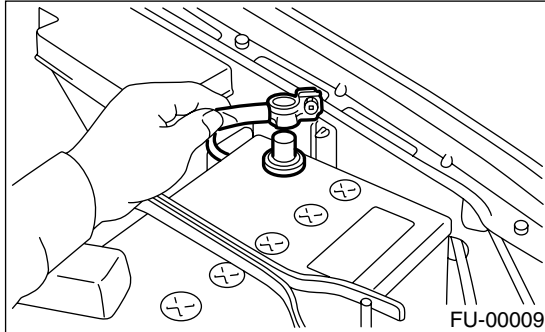

2) Remove the lower inner trim of the passenger side.

<Ref. to EI-48, REMOVAL, Lower Inner Trim.>

3) Detach the floor mat of the front passenger seat.

4) Remove the protect cover.

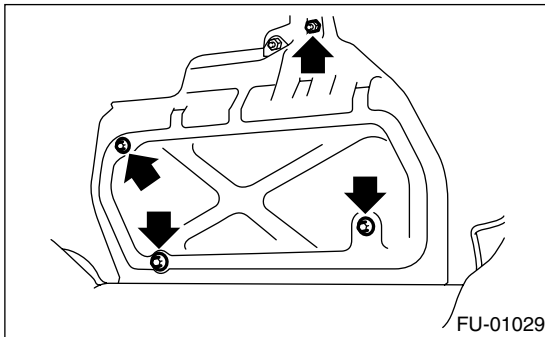

5) Remove the nuts (A) which hold ECM to the bracket.

6) Remove the clip (B) from the bracket.

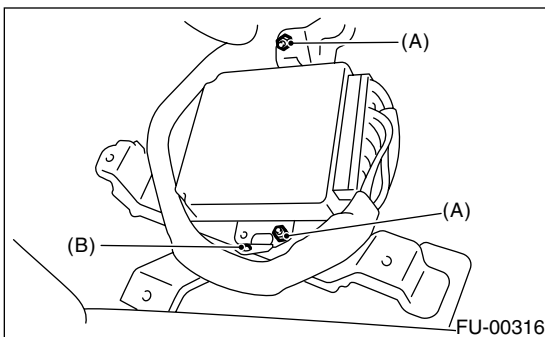

7) Disconnect the ECM connectors and take out the ECM.

B: INSTALLATION

Install in the reverse order of removal.

NOTE:

When replacing ECM, be careful not to use the wrong spec. ECM to avoid any damage to the fuel injection system.

Brought to you by Eris Studios
NOT FOR RESALE

17.Main Relay

A: REMOVAL

1) Disconnect the ground cable from battery.

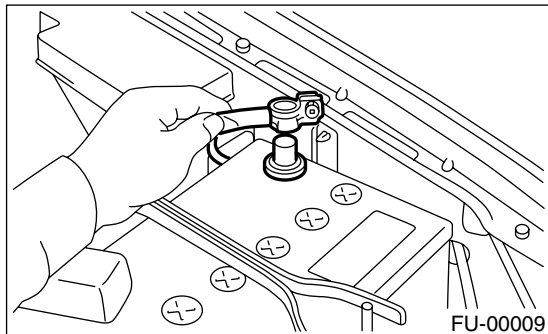

2) Remove the passenger's side front side sill cover.

3) Remove the bolt which holds the main relay bracket on the body.

4) Disconnect the connectors from the main relay.

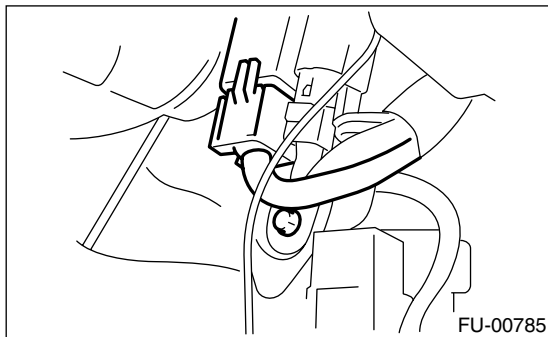

B: INSTALLATION

Install in the reverse order of removal.

18. Fuel Pump Relay

A: REMOVAL

- 1) Disconnect the ground cable from battery.

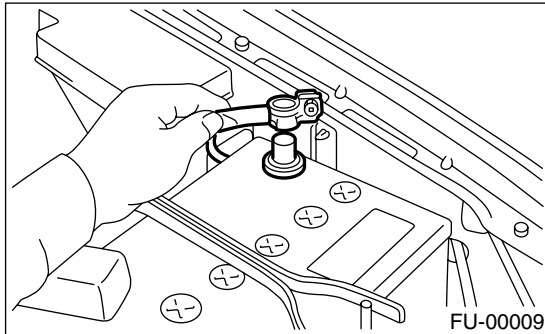

- 2) Remove the passenger's side front side sill cover.
- 3) Remove the bolt which holds fuel pump relay bracket on the body.
- 4) Disconnect the connector from the fuel pump relay.

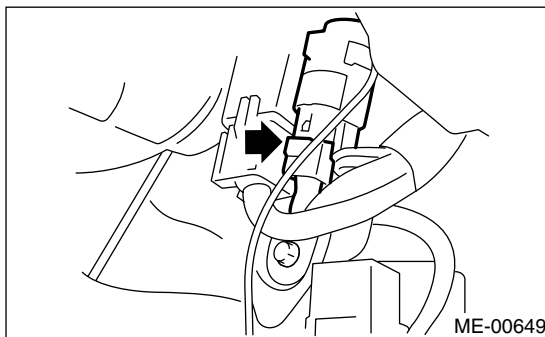

- 5) Remove the fuel pump relay from the mounting bracket.

B: INSTALLATION

Install in the reverse order of removal.

FUEL PUMP CONTROL UNIT

FUEL INJECTION (FUEL SYSTEMS)

19. Fuel Pump Control Unit

A: REMOVAL

1) Disconnect the ground cable from battery.

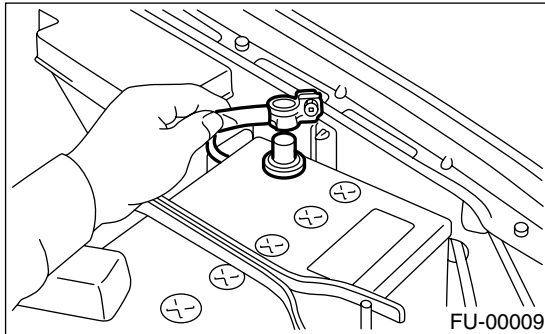

2) Remove the rear quarter trim. <Ref. to EI-49, REMOVAL, Rear Quarter Trim.>

3) Disconnect the connector from the fuel pump control unit.

4) Remove the fuel pump control unit.

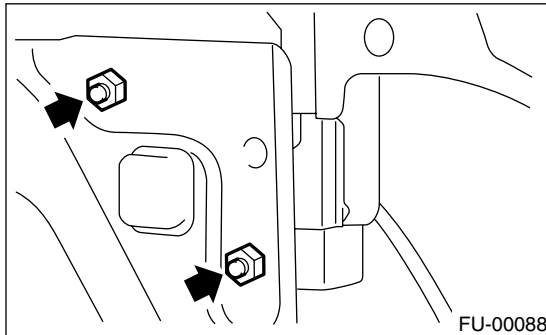

B: INSTALLATION

Install in the reverse order of removal.

20. Fuel

A: OPERATION

1. RELEASING OF FUEL PRESSURE

WARNING:

- Place “NO FIRE” signs near the working area.
- Be careful not to spill the fuel.

- 1) Disconnect the connector from the fuel pump relay.

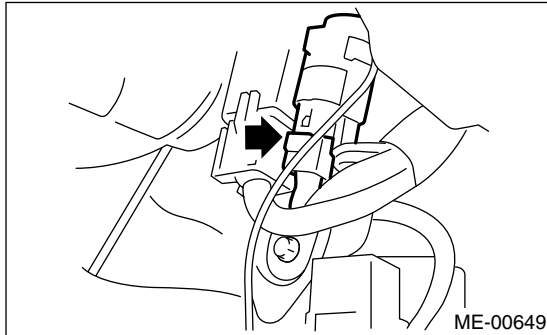

- 2) Start and run the engine until it stalls.
- 3) After the engine stalls, crank it for five more seconds.
- 4) Turn the ignition switch to OFF.

2. DRAINING FUEL

WARNING:

- Place “NO FIRE” signs near the working area.
- Be careful not to spill the fuel.

- 1) Set the vehicle on a lift.
- 2) Disconnect the ground cable from battery.

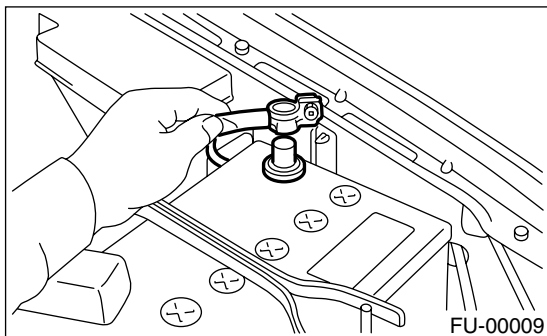

- 3) Open the fuel filler flap lid, and remove the fuel filler cap.
- 4) Lift-up the vehicle.

- 5) Drain the fuel from the fuel tank. Set a container under the vehicle, and remove drain plug from the fuel tank.

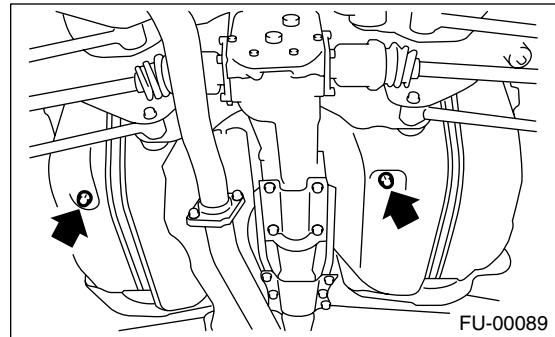

- 6) Tighten the fuel drain plug.

Tightening torque:

26 N·m (2.65 kgf·m, 19.2 ft·lb)

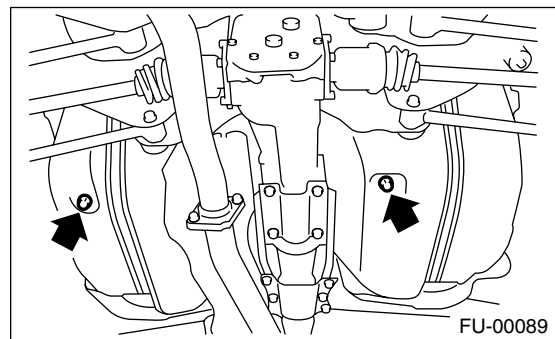

21. Fuel Tank

A: REMOVAL

WARNING:

- Place “NO FIRE” signs near the working area.
- Be careful not to spill the fuel.

- 1) Set the vehicle on a lift.
- 2) Release the fuel pressure. <Ref. to FU(STi)-45, RELEASING OF FUEL PRESSURE, OPERATION, Fuel.>
- 3) Drain the fuel from the fuel tank. <Ref. to FU(STi)-45, DRAINING FUEL, OPERATION, Fuel.>
- 4) Remove the rear seat.
- 5) Disconnect the connector (A) of fuel tank cord to the rear harness.
- 6) Push the grommet (B) which holds the fuel tank cord on floor panel into under the body.

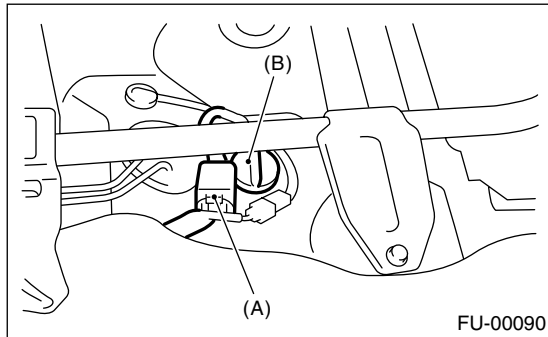

- 7) Remove the rear crossmember. <Ref. to RS-18, REMOVAL, Rear Crossmember.>
- 8) Move the clamp, and disconnect the evaporation hose from canister.

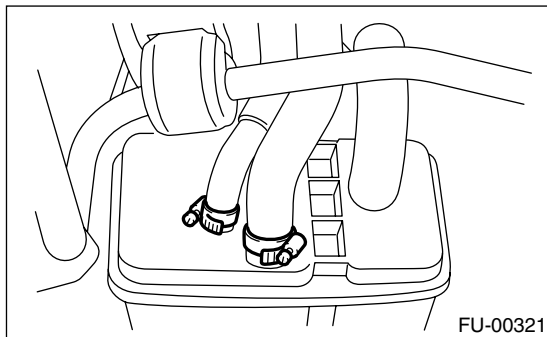

- 9) Disconnect the connector from the pressure control solenoid valve.

- 10) Disconnect the connector from the drain valve.

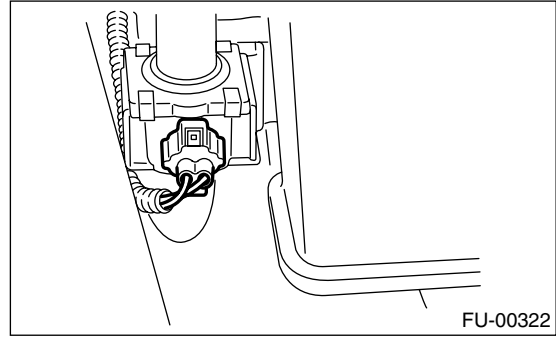

- 11) Loosen the clamp and disconnect the fuel filler hose (A) from fuel filler pipe.
- 12) Move the clip, and disconnect the evaporation hose (B).

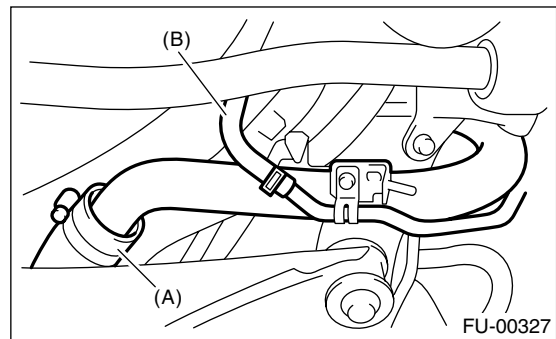

- 13) Move the clips, and disconnect the quick connector. <Ref. to FU(STi)-63, REMOVAL, Fuel Delivery, Return and Evaporation Lines.>
- 14) Disconnect the fuel hoses.

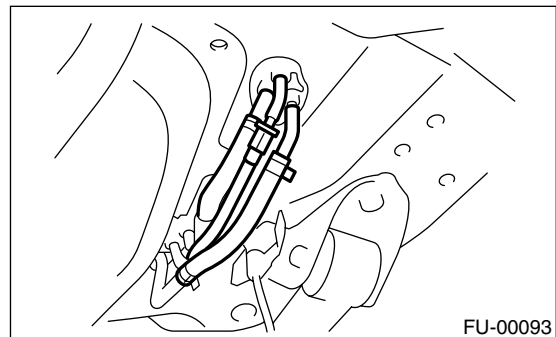

FUEL TANK

FUEL INJECTION (FUEL SYSTEMS)

15) Support the fuel tank with transmission jack, remove the bolts from bands and dismount the fuel tank from vehicle.

WARNING:

A helper is required to perform this work.

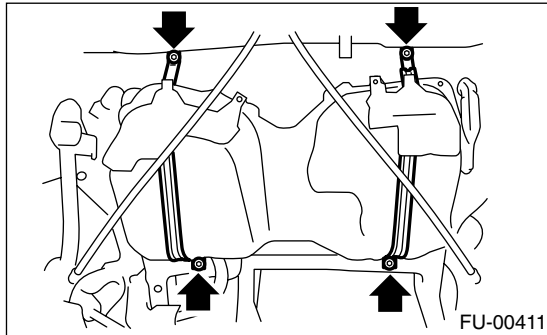

B: INSTALLATION

1) Support the fuel tank with transmission jack and push the fuel tank harness into the access hole with grommet.
2) Set the fuel tank and temporarily tighten the bolts of fuel tank bands.

WARNING:

A helper is required to perform this work.

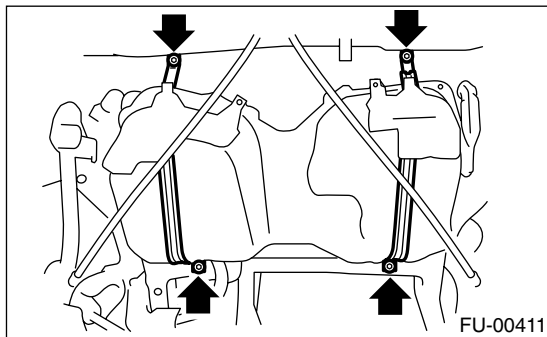

3) Insert the fuel filler hose (A) approx. 35 to 40 mm (1.38 to 1.57 in) over the lower end of fuel filler pipe and tighten the clamp.

CAUTION:

Do not allow clips to touch air vent hose (B) and rear suspension crossmember.

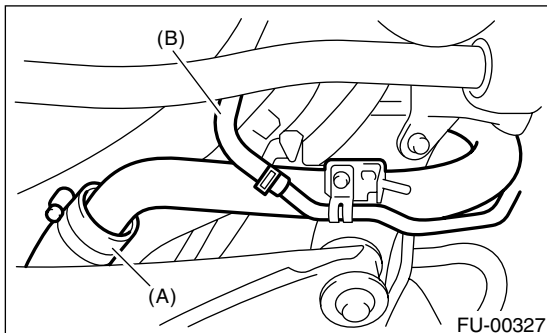

4) Connect the fuel hoses, and hold them with clips and quick connector. <Ref. to FU(STi)-64, INSTALLATION, Fuel Delivery, Return and Evaporation Lines.>

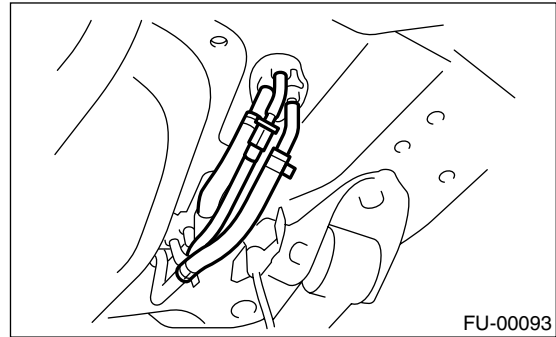

5) Connect the connector to the drain valve.

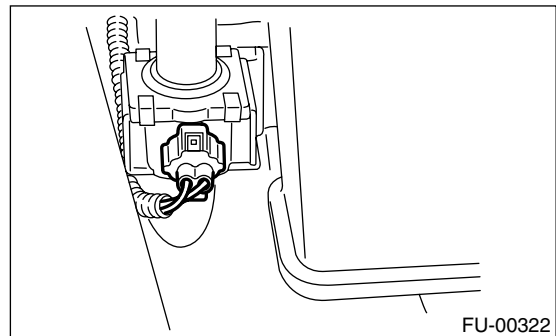

6) Connect the connector to the pressure control solenoid valve.

7) Connect the evaporation hose to the canister, and hold them with clamp.

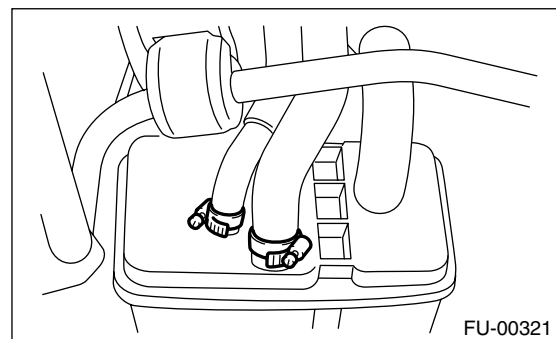

FUEL TANK

FUEL INJECTION (FUEL SYSTEMS)

8) Tighten the band mounting bolts.

Tightening torque:

33 N·m (3.4 kgf·m, 25 ft·lb)

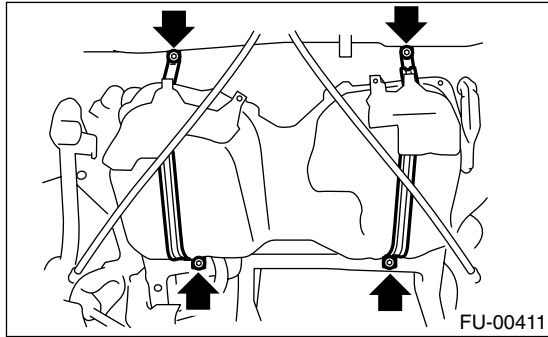

9) Install the rear crossmember. <Ref. to RS-18, INSTALLATION, Rear Crossmember.>

10) Connect the connector (A) to the fuel tank cord and plug the service hole with grommet (B).

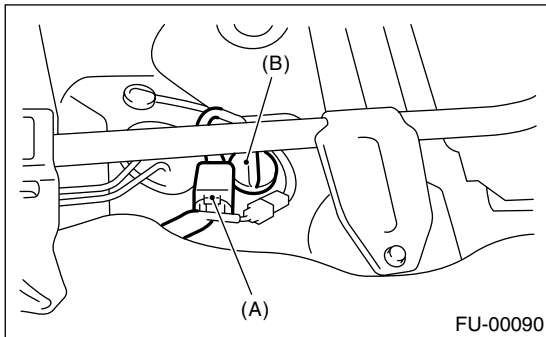

11) Set the rear seat and floor mat.

12) Connect the connector to the fuel pump relay.

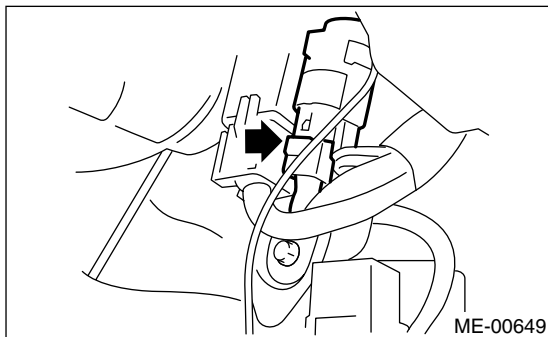

C: INSPECTION

1) Make sure there are no cracks, holes, or other damage on the fuel tank.

2) Make sure that the fuel hoses and fuel pipes are not cracked and the connections are tightened firmly.

22. Fuel Filler Pipe

A: REMOVAL

WARNING:

- Place “NO FIRE” signs near the working area.
- Be careful not to spill the fuel.

- 1) Set the vehicle on a lift.
- 2) Release the fuel pressure. <Ref. to FU(STi)-45, RELEASING OF FUEL PRESSURE, OPERATION, Fuel.>
- 3) Open the fuel filler flap lid and remove the filler cap.
- 4) Disconnect the ground cable from battery.

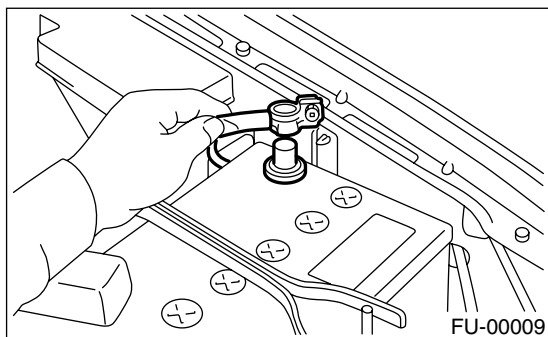

- 5) Remove the screws holding packing.

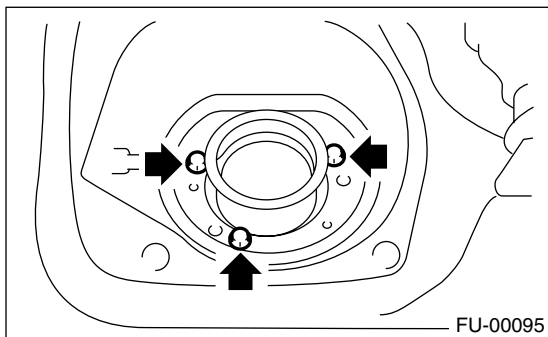

- 6) Loosen the rear right side wheel nuts.
- 7) Lift-up the vehicle.
- 8) Remove the rear right side wheel.

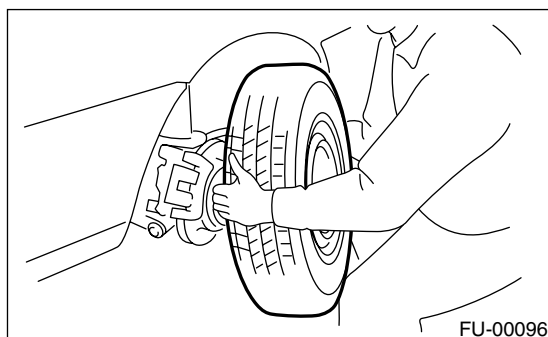

- 9) Drain the fuel from fuel tank. Set a container under the vehicle and remove the drain plug from fuel tank.

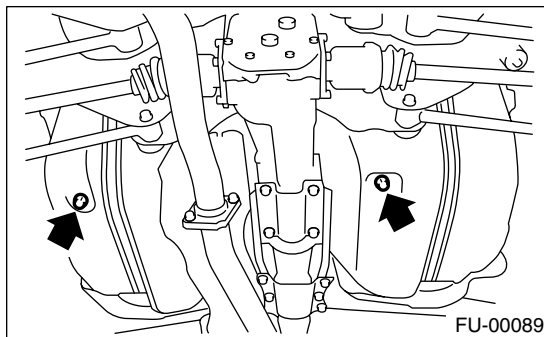

- 10) Tighten the fuel drain plug and then install the front right side tank cover.

Tightening torque:

26 N·m (2.65 kgf·m, 19.2 ft·lb)

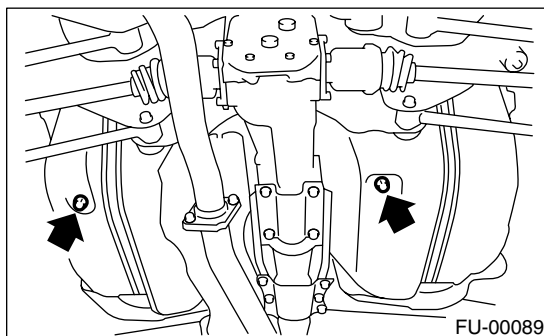

- 11) Remove the fuel filler pipe protector.

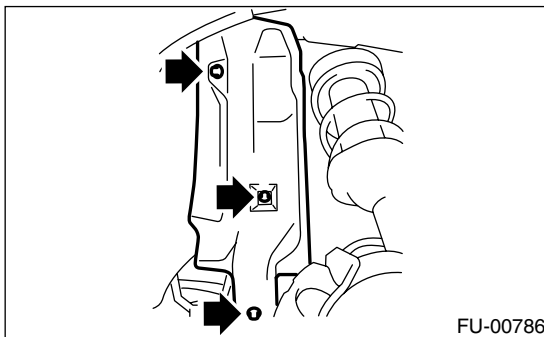

- 12) Separate the evaporation hoses from the clip of fuel filler pipe.

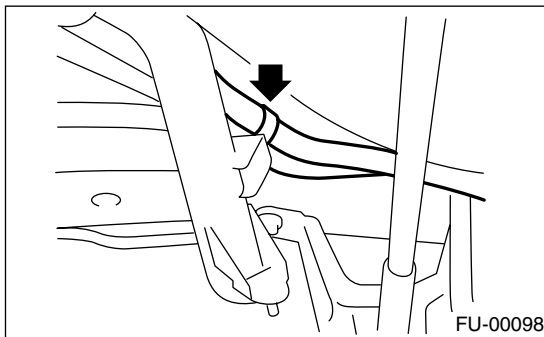

FUEL FILLER PIPE

FUEL INJECTION (FUEL SYSTEMS)

13) Disconnect the evaporation hoses from the pipes.

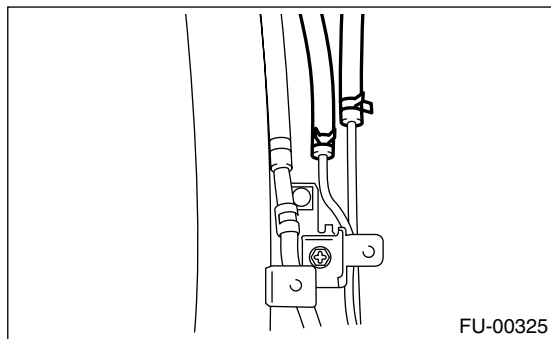

18) Remove the air vent pipe together with clip from the body.

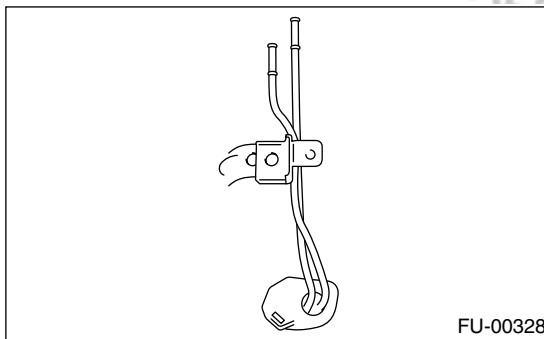

14) Remove the bolts which hold fuel filler pipe bracket on the body.

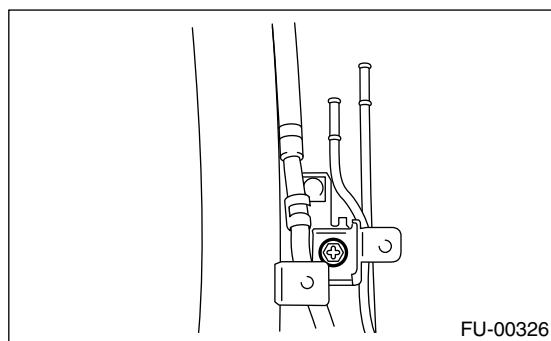

15) Loosen the clamp, and disconnect the fuel filler hose (A) from fuel filler pipe.

16) Move the clip, and disconnect the evaporation hose (B).

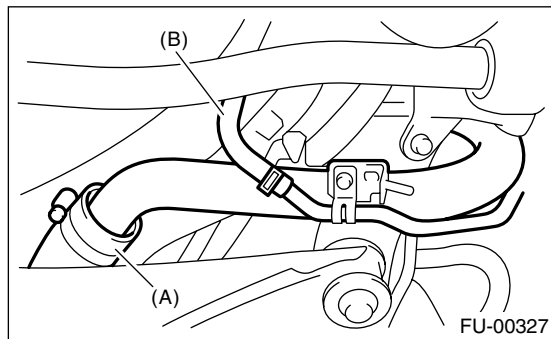

17) Remove the fuel filler pipe to the underside of vehicle.

B: INSTALLATION

1) Hold the fuel filler flap open.

2) Set the fuel saucer (A) with rubber packing (C), and then insert the fuel filler pipe into the hole from the inside of apron.

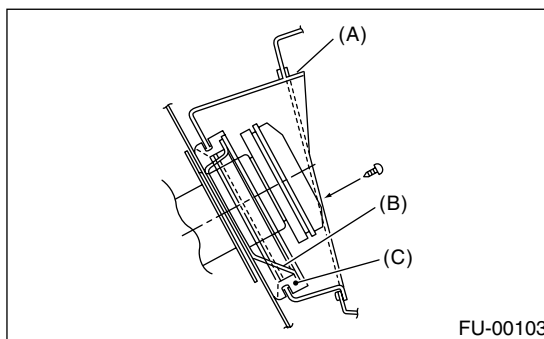

3) Align the holes in fuel filler pipe neck and set the cup (B), and tighten the screws.

NOTE:

If the edges of rubber packing are folded toward the inside, straighten them with a screwdriver.

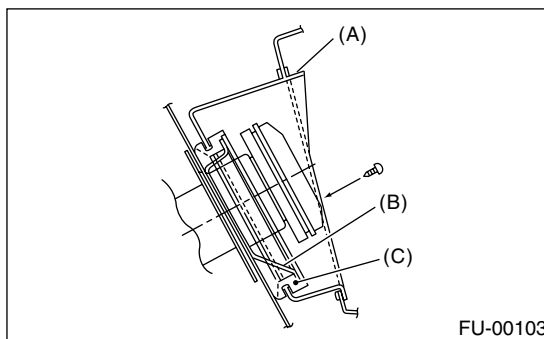

FUEL FILLER PIPE

FUEL INJECTION (FUEL SYSTEMS)

4) Install the evaporation pipes.

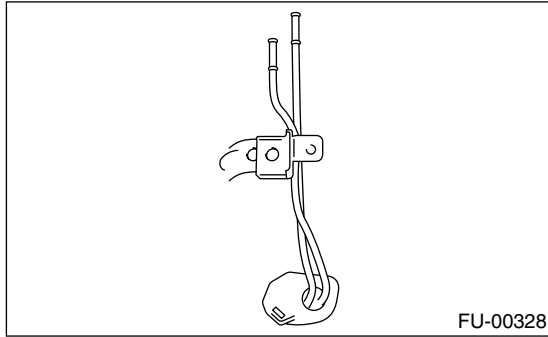

5) Connect the evaporation hose to pipes.

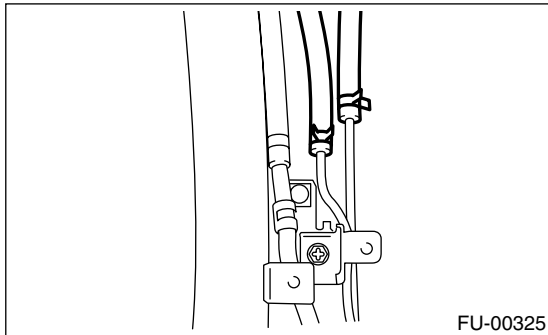

6) Insert the fuel filler hose (A) approx. 35 to 40 mm (1.38 to 1.57 in) over the lower end of fuel filler pipe, and then tighten the clamp.

CAUTION:
Do not allow clips to touch air vent hose (B) and rear suspension crossmember.

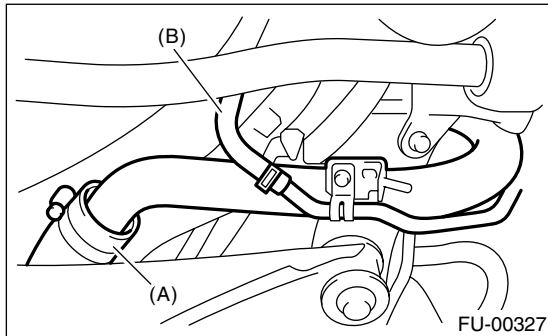

7) Insert the air vent hose approx. 25 to 30 mm (0.98 to 1.18 in) into the lower end of air vent pipe, and then hold the clip.

$L = 27.5 \pm 2.5 \text{ mm (1.083 \pm 0.098 in)}$

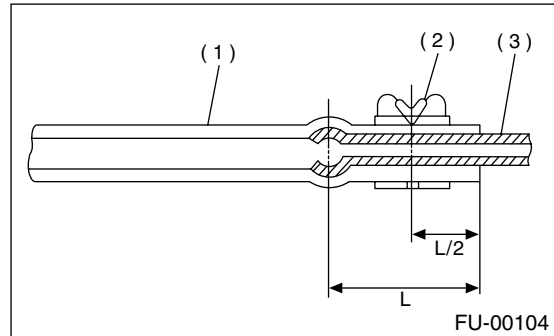

- (1) Hose
- (2) Clip
- (3) Pipe

8) Tighten the bolt which holds fuel filler pipe bracket on the body.

Tightening torque:
 $7.4 \text{ N}\cdot\text{m (0.75 kgf}\cdot\text{m, 5.4 ft}\cdot\text{lb)}$

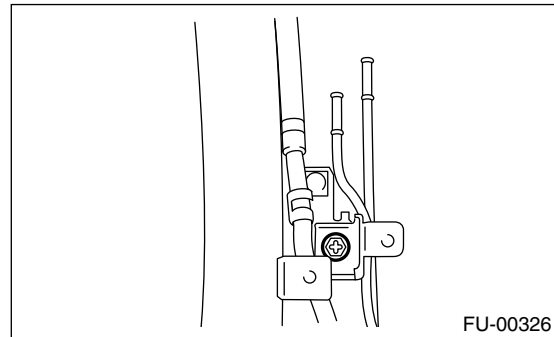

9) Tighten the bolts which hold evaporation hoses onto the clip of fuel filler pipe.

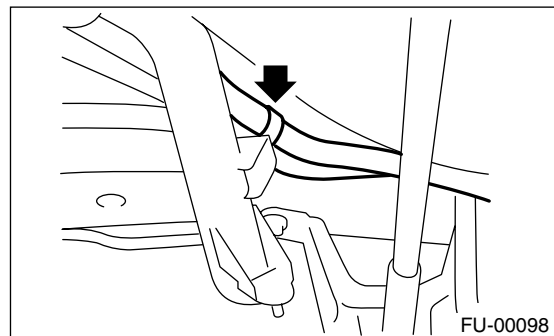

FUEL FILLER PIPE

FUEL INJECTION (FUEL SYSTEMS)

10) Install the fuel filler pipe protector.

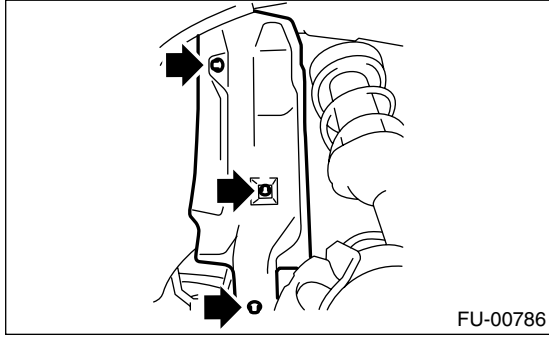

11) Install the rear right wheel.

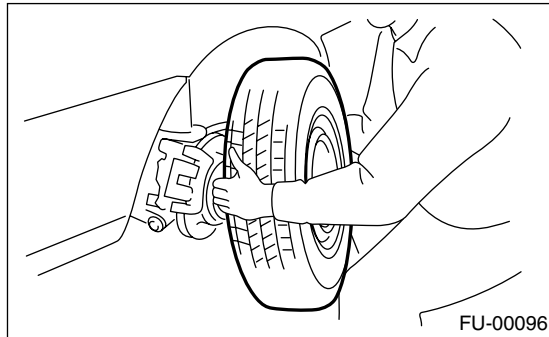

12) Lower the vehicle.

13) Tighten the wheel nuts.

14) Connect the connector to the fuel pump relay.

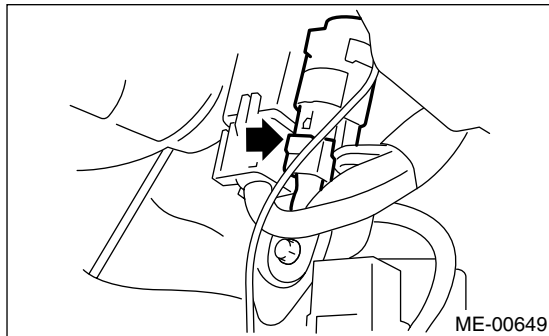

15) Connect the battery ground cable to battery.

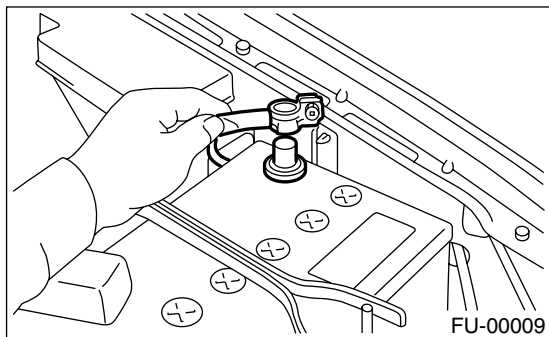

C: DISASSEMBLY

1) Move the clip, and disconnect the evaporation hose from joint pipe.

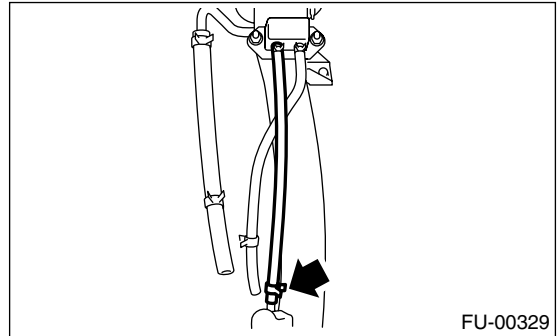

2) Remove the bolt which installs the joint pipe on fuel filler pipe.

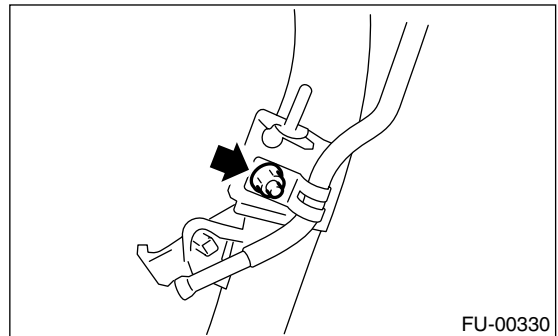

3) Disconnect the evaporation hose from the fuel filler pipe.

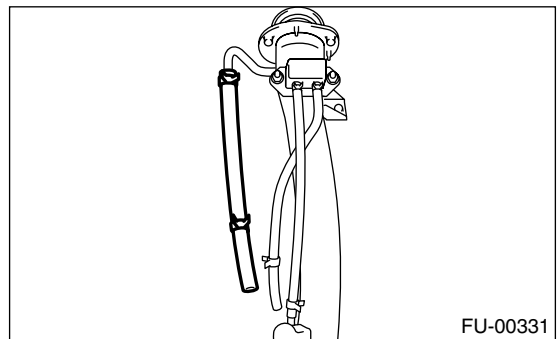

4) Remove the shut valve from the fuel filler pipe.
<Ref. to EC(STi)-17, REMOVAL, Shut Valve.>

D: ASSEMBLY

- 1) Install the shut valve on the fuel filler pipe. <Ref. to EC(STi)-17, INSTALLATION, Shut Valve.>
- 2) Connect the evaporation hose to the fuel filler pipe.

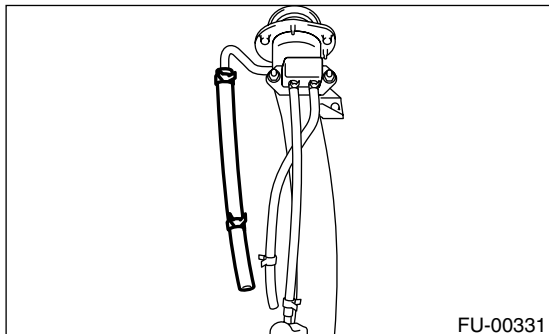

- 3) Connect the evaporation hose to the evaporation pipe.

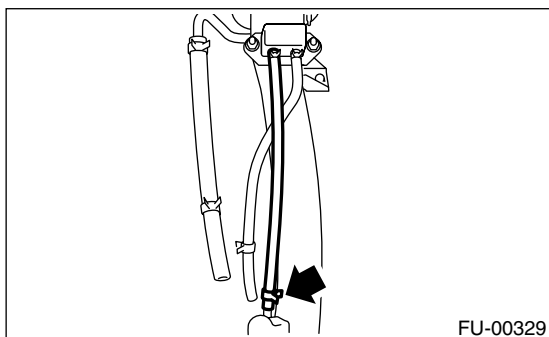

- 4) Install the evaporation pipe to the fuel filler pipe.

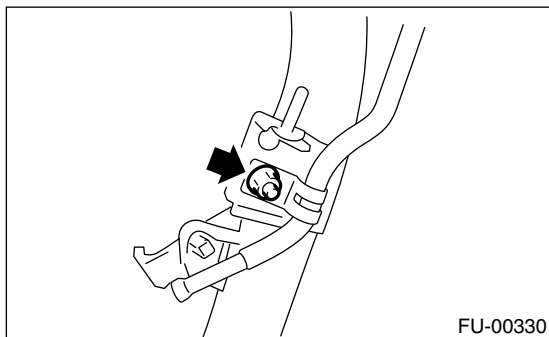

23. Fuel Pump

A: REMOVAL

WARNING:

- Place “NO FIRE” signs near the working area.
- Be careful not to spill the fuel.

NOTE:

Fuel pump assembly consists of fuel pump and fuel level sensor.

- 1) Release the fuel pressure. <Ref. to FU(STi)-45, RELEASING OF FUEL PRESSURE, OPERATION, Fuel.>
- 2) Open the fuel filler flap lid and remove the fuel filler cap.
- 3) Disconnect the ground cable from battery.

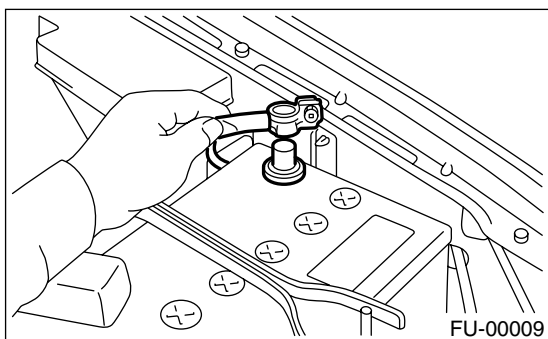

- 4) Lift-up the vehicle.
- 5) Drain the fuel from fuel tank. Set a container under the vehicle and remove the drain plug from fuel tank.

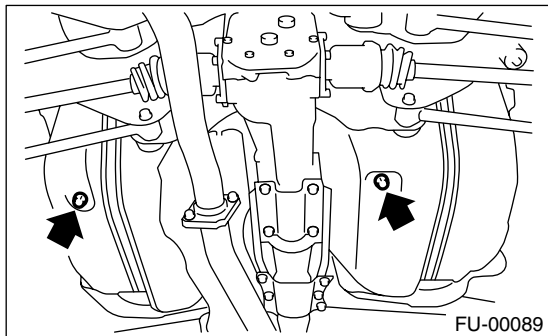

- 6) Tighten the fuel drain plug.

Tightening torque:

26 N·m (2.65 kgf·m, 19.2 ft·lb)

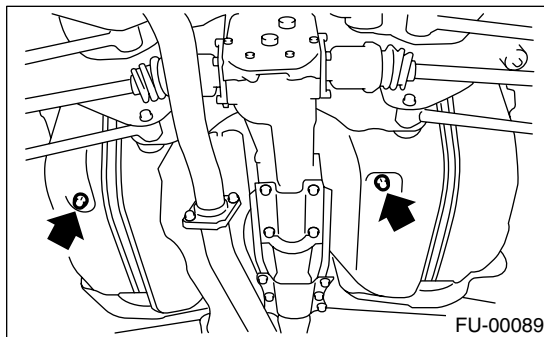

- 7) Raise the rear seat and turn the floor mat up.
- 8) Remove the access hole lid.

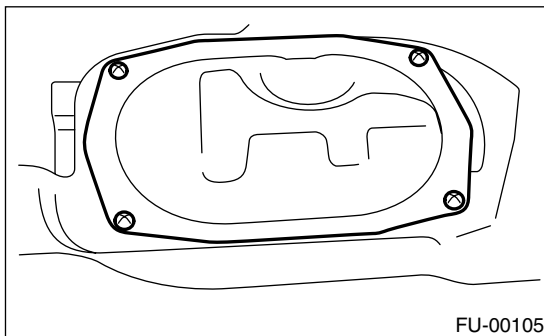

- 9) Disconnect the connector from the fuel pump.

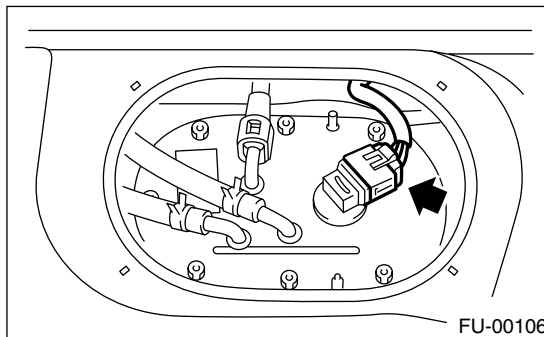

- 10) Disconnect the quick connector and then disconnect the fuel delivery hose (A). <Ref. to FU(STi)-63, Fuel Delivery, Return and Evaporation Lines.>

FUEL PUMP

FUEL INJECTION (FUEL SYSTEMS)

11) Move the clips, and then disconnect the fuel return hose (A) and jet pump hose (B).

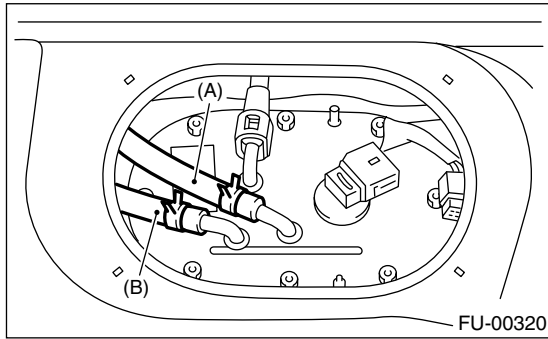

12) Remove the nuts which install the fuel pump assembly onto fuel tank.

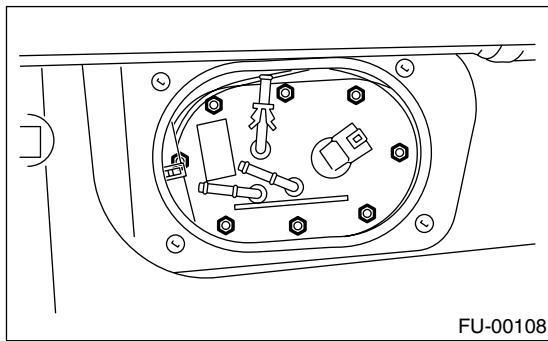

13) Take off the fuel pump assembly from the fuel tank.

B: INSTALLATION

Carefully following the steps below, install in the reverse order of removal.

NOTE:

Always use new gaskets.

(1) Ensure the sealing portion is free from fuel or foreign particles before installation.

(2) Tighten the nuts to the specified torque in alphabetical sequence as shown in the figure.

Tightening torque:

4.4 N·m (0.45 kgf-m, 3.3 ft-lb)

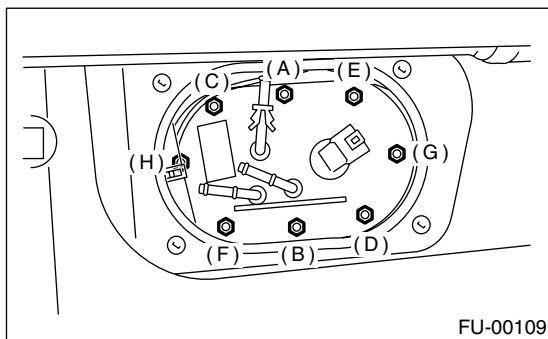

C: DISASSEMBLY

1) Separate the chamber into upper and lower parts, and then remove them.

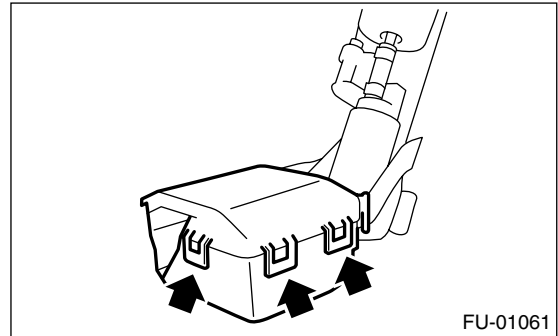

2) Disconnect the connector of fuel pump.

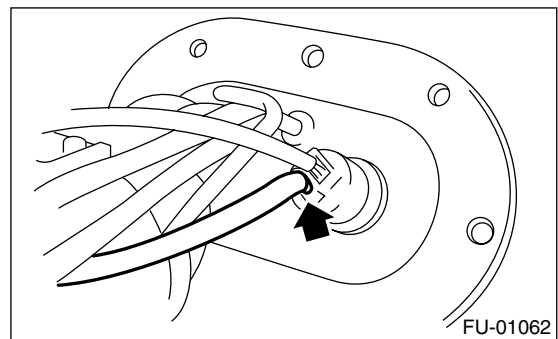

3) Remove the screw and remove the fuel pump and fuel filter.

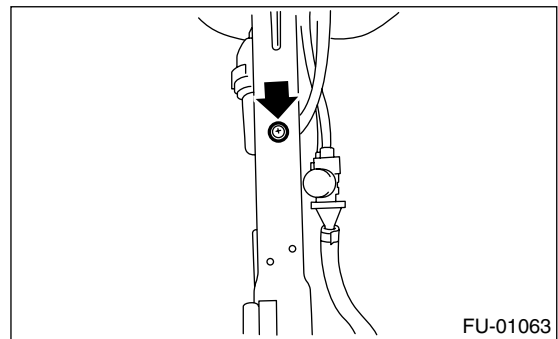

4) Separate the fuel filter from fuel pump.

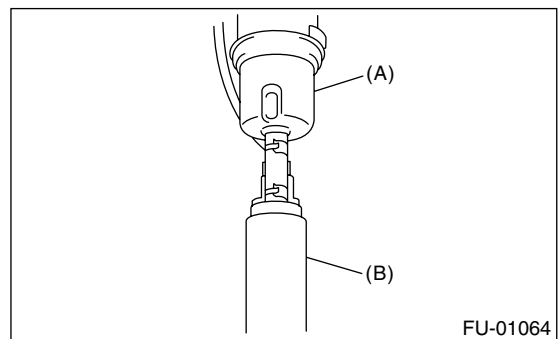

(A) Fuel filter

(B) Fuel pump

FUEL PUMP

FUEL INJECTION (FUEL SYSTEMS)

D: ASSEMBLY

Assemble in the reverse order of disassembly.

E: INSPECTION

Connect the lead harness to the connector terminal of fuel pump and apply battery power supply to check whether the pump operate.

WARNING:

- Wipe off the fuel completely.
- Keep battery as far apart from fuel pump as possible.
- Be sure to turn the battery supply ON and OFF on the battery side.
- Do not run fuel pump for a long time under non-load condition.

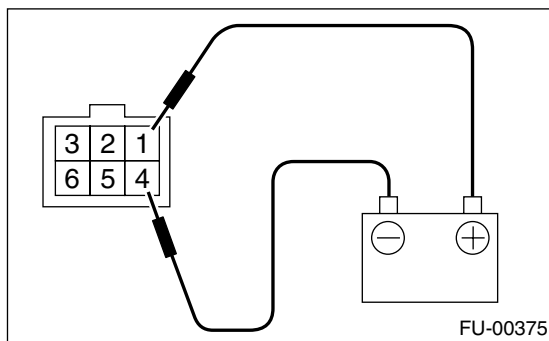

24. Fuel Level Sensor

A: REMOVAL

WARNING:

- Place “NO FIRE” signs near the working area.
- Be careful not to spill the fuel.

NOTE:

Fuel level sensor is built in fuel pump assembly.

- 1) Remove the fuel pump assembly. <Ref. to FU(STi)-54, REMOVAL, Fuel Pump.>
- 2) Disconnect the connector from the fuel pump bracket.

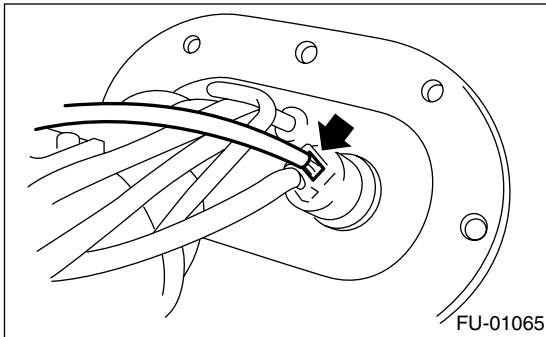

- 3) Remove the fuel temperature sensor.

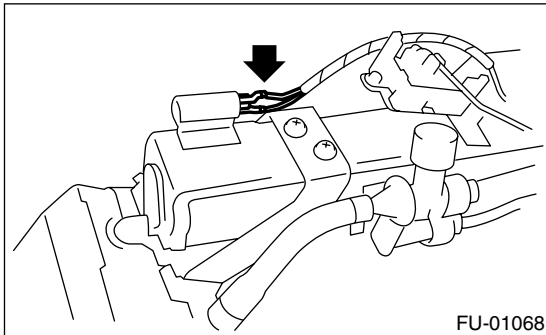

- 4) Remove the bolt which installs the fuel level sensor on mounting bracket.

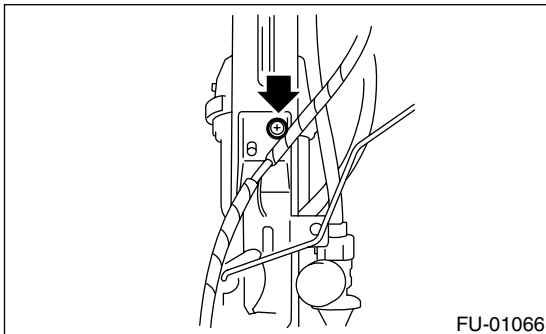

B: INSTALLATION

Install in the reverse order of removal.

FUEL SUB LEVEL SENSOR

FUEL INJECTION (FUEL SYSTEMS)

25. Fuel Sub Level Sensor

A: REMOVAL

WARNING:

- Place "NO FIRE" signs near the working area.
- Be careful not to spill the fuel.

1) Disconnect the ground cable from battery.

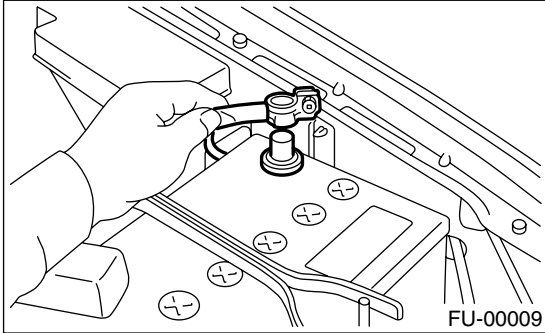

2) Lift-up the vehicle.

3) Drain the fuel from the fuel tank. Set a container under the vehicle and remove the drain plug from fuel tank.

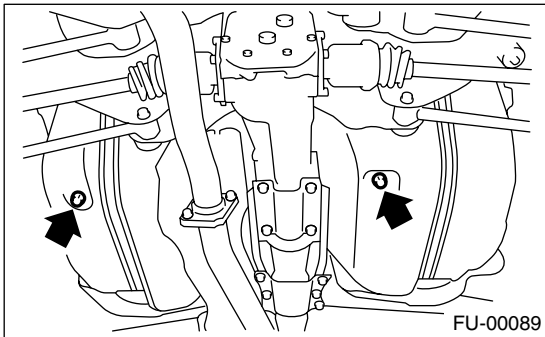

4) Tighten the fuel drain plug.

Tightening torque:

26 N·m (2.65 kgf·m, 19.2 ft·lb)

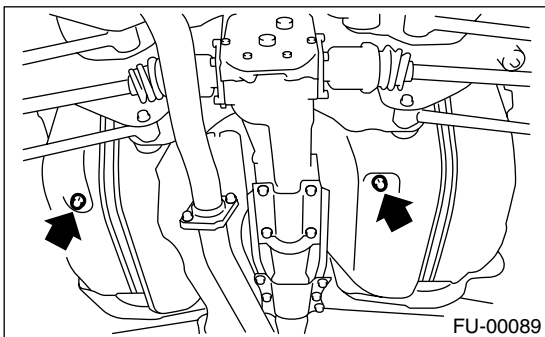

5) Remove the rear seat.

6) Remove the service hole cover.

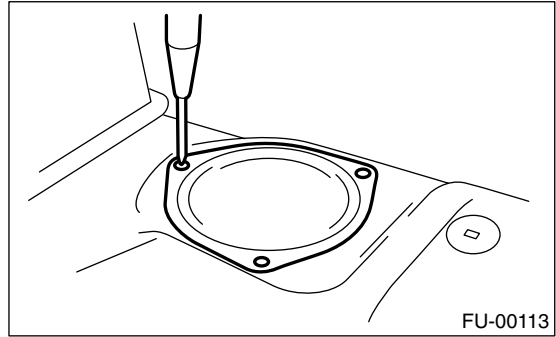

7) Disconnect the connector from the fuel sub level sensor.

8) Disconnect the fuel jet pump hose.

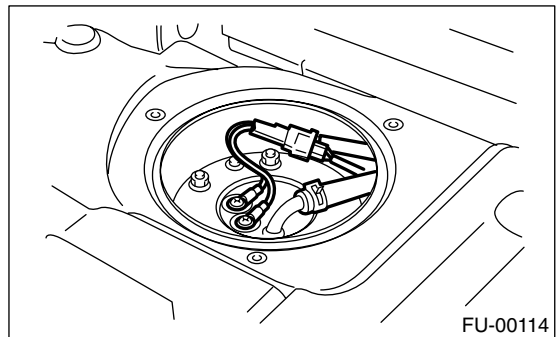

9) Remove the bolts which install the fuel sub level sensor on fuel tank.

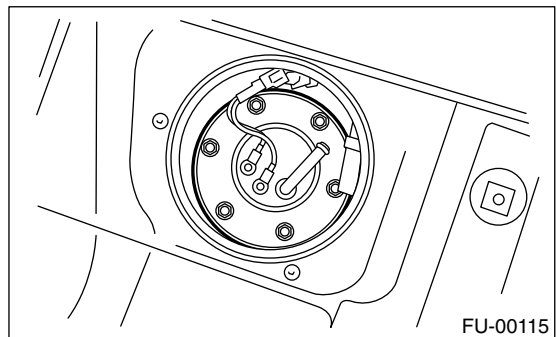

10) Remove the fuel sub level sensor.

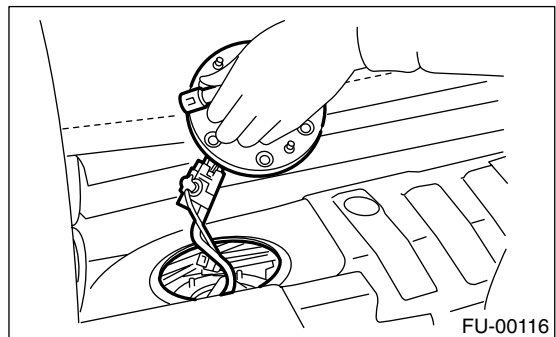

FUEL SUB LEVEL SENSOR

FUEL INJECTION (FUEL SYSTEMS)

B: INSTALLATION

Install in the reverse order of removal.

Tightening torque:

4.4 N·m (0.45 kgf-m, 3.3 ft-lb)

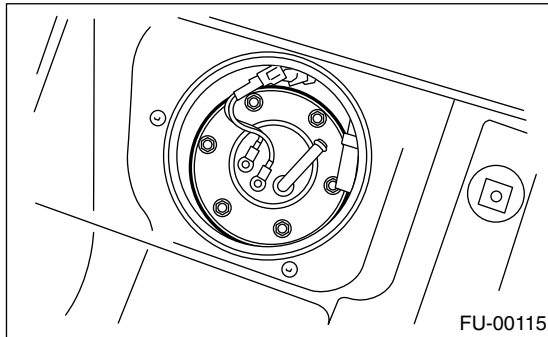

26. Fuel Filter

A: REMOVAL

WARNING:

- Place "NO FIRE" signs near the working area.
- Be careful not to spill the fuel.

NOTE:

Fuel filter is built into the fuel pump assembly.

- 1) Release the fuel pressure. <Ref. to FU(STi)-45, RELEASING OF FUEL PRESSURE, OPERATION, Fuel.>
- 2) Remove the fuel pump assembly. <Ref. to FU(STi)-54, REMOVAL, Fuel Pump.>
- 3) Remove the fuel pump. <Ref. to FU(STi)-55, DISASSEMBLY, Fuel Pump.>
- 4) Separate the fuel filter from fuel pump.

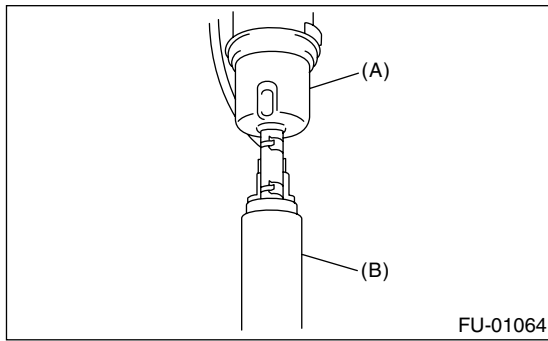

- (A) Fuel filter
(B) Fuel pump

- 5) Turn the filter holder around to the arrow direction, and then remove the filter.

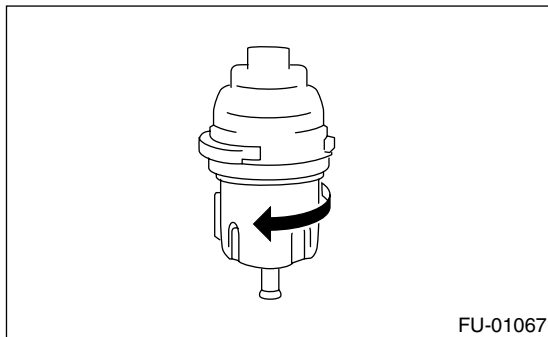

B: INSTALLATION

CAUTION:

- If fuel hoses are damaged at the connecting portion, replace them with new ones.
- If clamps are badly damaged, replace them with new ones.

Install in the reverse order of removal.

C: INSPECTION

- 1) Check the inside of fuel filter for dirt and water sediment.
- 2) If it is clogged, or if replacement interval has been reached, replace it.

27. Fuel Cut Valve

A: REMOVAL

- 1) Remove the fuel tank. <Ref. to FU(STi)-46, REMOVAL, Fuel Tank.>
- 2) Remove the protect cover.

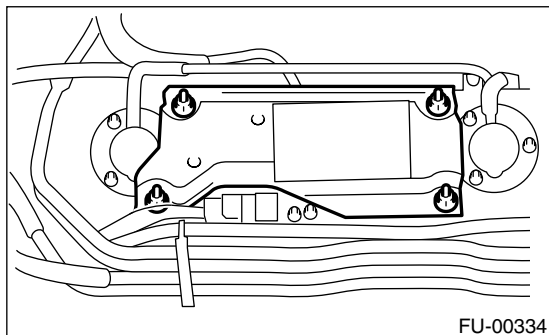

- 3) Move the clip and disconnect the evaporation hose from fuel cut valve.

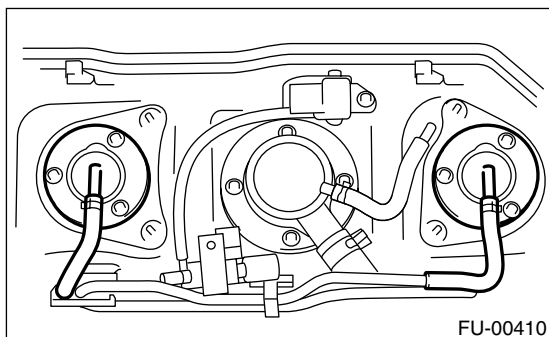

- 4) Remove the bolts which install the fuel cut valve.

B: INSTALLATION

Install in the reverse order of removal.

Tightening torque:

4.4 N·m (0.45 kgf·m, 3.3 ft·lb)

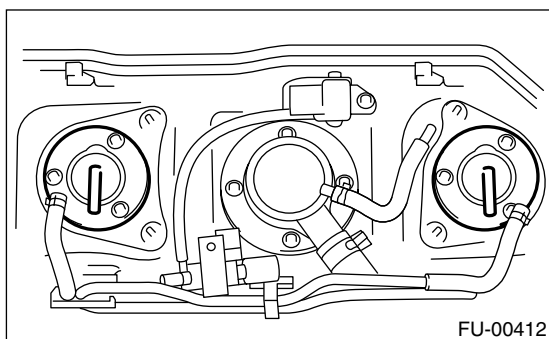

FUEL DAMPER VALVE

FUEL INJECTION (FUEL SYSTEMS)

28. Fuel Damper Valve

A: REMOVAL

1) Release the fuel pressure. <Ref. to FU(STi)-45, RELEASING OF FUEL PRESSURE, OPERATION, Fuel.>

2) Remove the fuel damper valve from the fuel delivery line (A) and fuel return line (B).

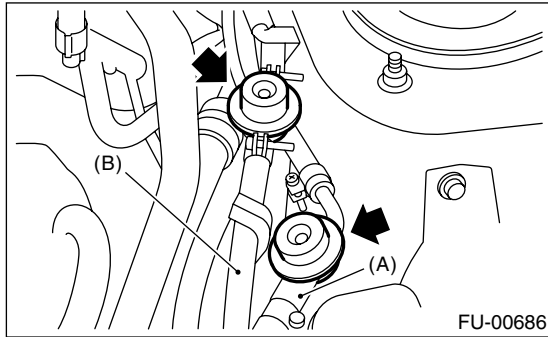

B: INSTALLATION

Install in the reverse order of removal.

Tightening torque:

1.25 N·m (0.13 kgf-m, 0.94 ft-lb)

FUEL DELIVERY, RETURN AND EVAPORATION LINES

FUEL INJECTION (FUEL SYSTEMS)

29. Fuel Delivery, Return and Evaporation Lines

A: REMOVAL

- 1) Set the vehicle on a lift.
- 2) Release the fuel pressure. <Ref. to FU(STi)-45, RELEASING OF FUEL PRESSURE, OPERATION, Fuel.>
- 3) Open the fuel filler flap lid and remove the fuel filler cap.
- 4) Remove the floor mat. <Ref. to EI-56, REMOVAL, Floor Mat.>
- 5) Remove the fuel delivery pipes and hoses, fuel return pipes and hoses, evaporation pipes and hoses.

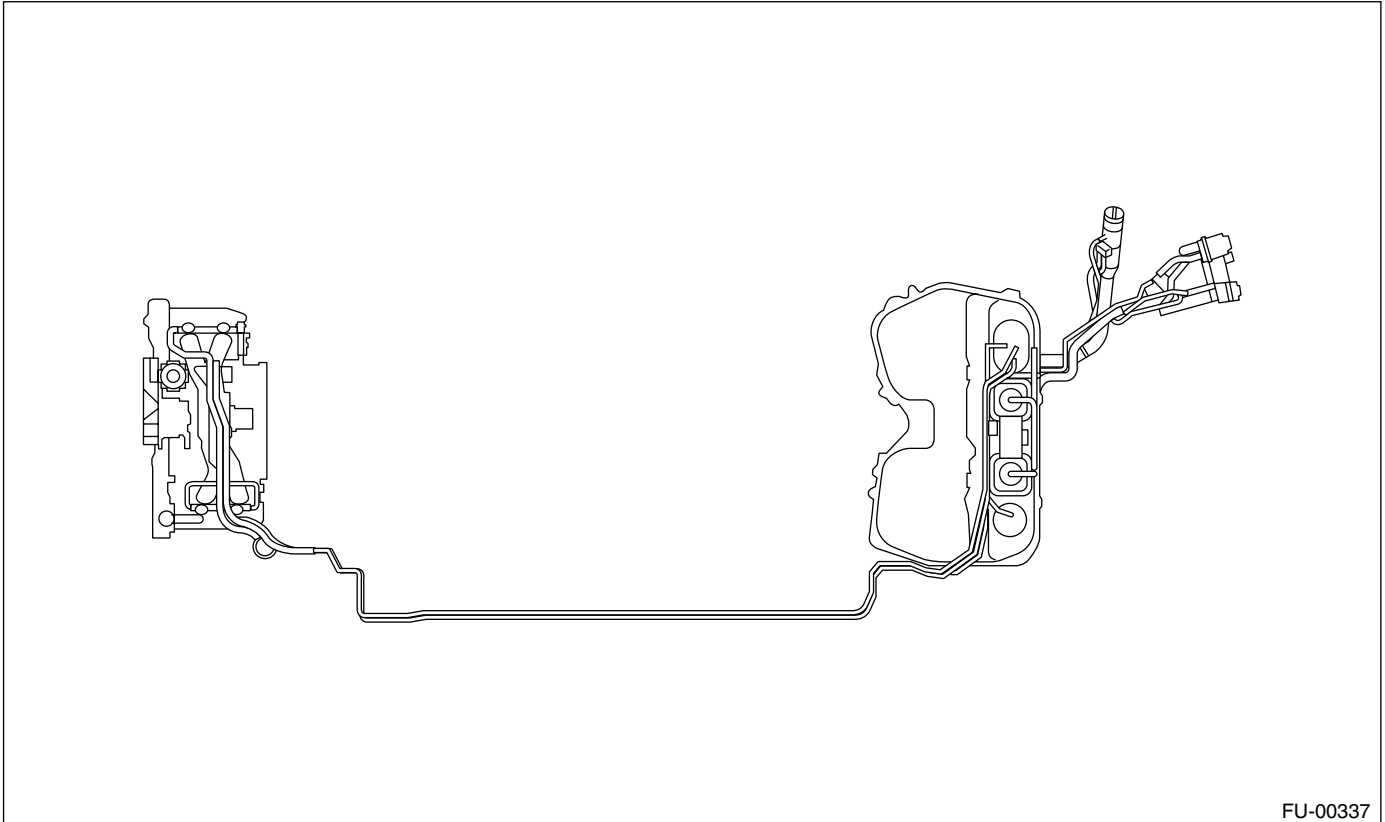

- 6) In engine compartment, detach the fuel delivery hose (A), return hose (B) and evaporation hose (C).

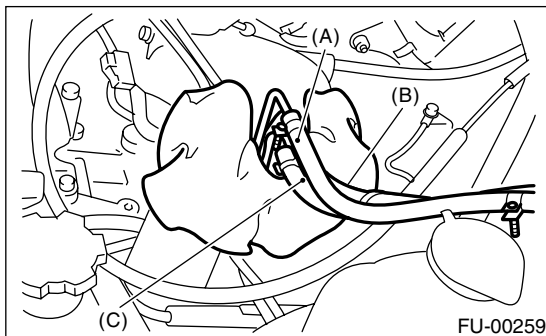

- 7) Lift-up the vehicle.

- 8) Separate the quick connector on the fuel delivery line.

- (1) Clean the pipe and connector, if they are covered with dust.
- (2) Hold the connector (A) and push retainer (B) down.

FUEL DELIVERY, RETURN AND EVAPORATION LINES

FUEL INJECTION (FUEL SYSTEMS)

(3) Pull out the connector (A) from retainer (B).

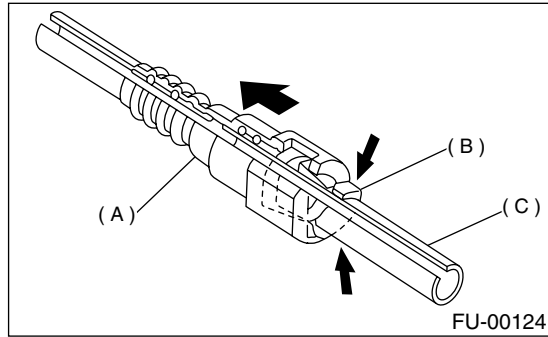

- (A) Connector
- (B) Retainer
- (C) Pipe

NOTE:

At this time, two clicking sounds are heard.

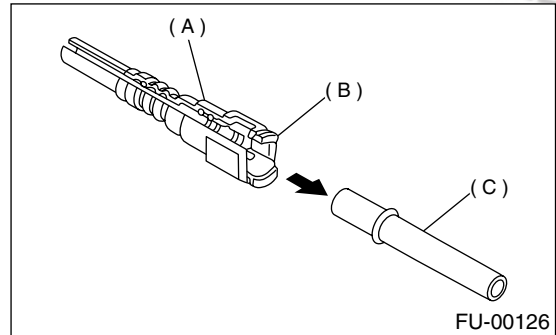

- (A) Connector
- (B) Retainer
- (C) Pipe

B: INSTALLATION

1) Connect the quick connector on the fuel delivery line.

NOTE:

- Always use a new retainer.
- Make sure that the connected portion is not damaged or has no dust. If necessary, clean seal surface of pipe.

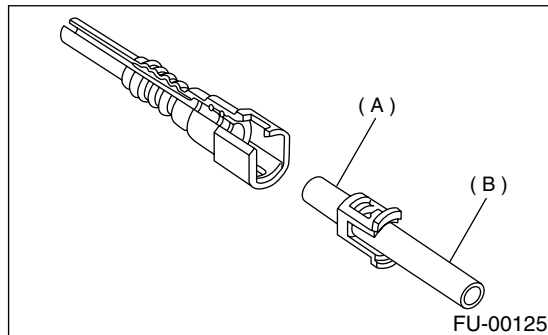

- (A) Seal surface
- (B) Pipe

- (1) Set a new retainer (B) to connector (A).
- (2) Push the pipe into the connector completely.

CAUTION:

- Pull the connector to ensure it is connected securely.
- Ensure the two retainer pawls are engaged in their mating positions in the connector.
- Be sure to inspect hoses and their connections for any leakage of fuel.

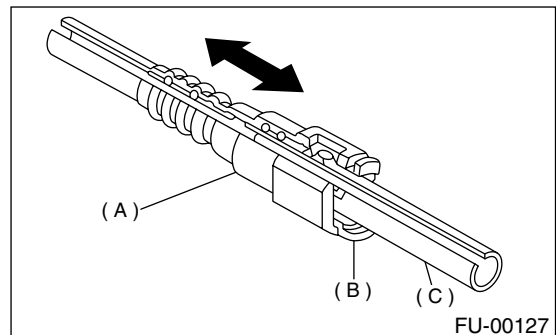

- (A) Connector
- (B) Retainer
- (C) Pipe

FUEL DELIVERY, RETURN AND EVAPORATION LINES

FUEL INJECTION (FUEL SYSTEMS)

2) Connect the fuel delivery hose and return hose to the pipe with an overlap of 20 to 25 mm (0.79 to 0.98 in).

Type A: When the fitting length is specified.

Type B: When the fitting length is not specified.

$\varnothing : 2.5 \pm 1.5 \text{ mm } (0.098 \pm 0.059 \text{ in})$

$L : 22.5 \pm 2.5 \text{ mm } (0.886 \pm 0.098 \text{ in})$

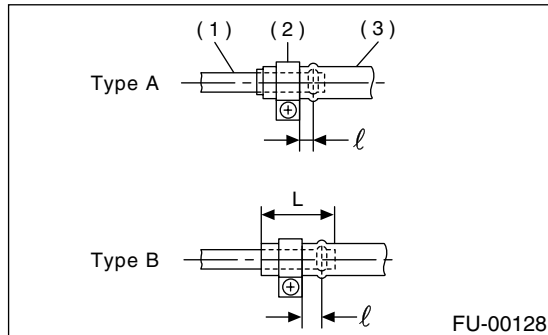

- (1) Fitting
- (2) Clamp
- (3) Hose

3) Connect the evaporation hose to the pipe with an overlap of 15 to 20 mm (0.59 to 0.79 in).

$L = 17.5 \pm 2.5 \text{ mm } (0.689 \pm 0.098 \text{ in})$

CAUTION:

Be sure to inspect hoses and their connections for any leakage of fuel.

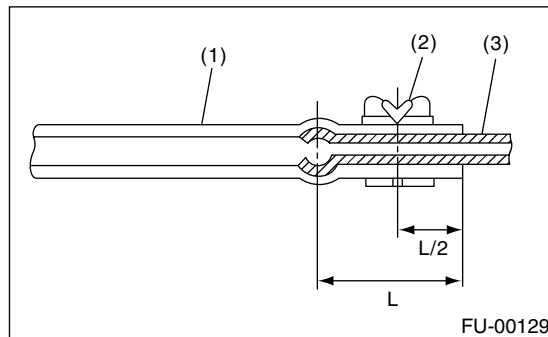

- (1) Hose
- (2) Clip
- (3) Pipe

C: INSPECTION

1) Make sure there are no cracks on the fuel pipes and fuel hoses.

2) Make sure the fuel pipe and fuel hose connections are tightened firmly.

FUEL SYSTEM TROUBLE IN GENERAL

FUEL INJECTION (FUEL SYSTEMS)

30. Fuel System Trouble in General

A: INSPECTION

Trouble and possible cause		Corrective action
1. Insufficient fuel supply to the injector		
1)	Fuel pump will not operate.	
	○ Defective terminal contact.	Inspect connections, especially ground, and tighten securely.
	○ Trouble in electromagnetic or electronic circuit parts.	Replace fuel pump.
2)	Lowering of fuel pump function.	Replace fuel pump.
3)	Clogged dust or water in the fuel filter.	Replace fuel filter, clean or replace fuel tank.
4)	Clogged or bent fuel pipe or hose.	Clean, correct or replace fuel pipe or hose.
5)	Air is mixed in the fuel system.	Inspect or retighten each connection part.
6)	Clogged or bent breather tube or pipe.	Clean, correct or replace air breather tube or pipe.
7)	Damaged diaphragm of pressure regulator.	Replace.
2. Leakage or blow out fuel		
1)	Loosened joints of the fuel pipe.	Retightening.
2)	Cracked fuel pipe, hose and fuel tank.	Replace.
3)	Defective welding part on the fuel tank.	Replace.
4)	Defective drain packing of the fuel tank.	Replace.
5)	Clogged or bent air breather tube or air vent tube.	Clean, correct or replace air breather tube or air vent tube.
3. Gasoline smell inside of compartment		
1)	Loose joints at air breather tube, air vent tube and fuel filler pipe.	Retightening.
2)	Defective packing air tightness on the fuel saucer.	Correct or replace packing.
3)	Cracked fuel separator.	Replace separator.
4)	Inoperative fuel pump modulator or circuit.	Replace.
4. Defective fuel meter indicator		
1)	Defective operation of fuel level sensor.	Replace.
2)	Defective operation of fuel meter.	Replace.
5. Noise		
1)	Large operation noise or vibration of fuel pump.	Replace.

NOTE:

- When the vehicle is left unattended for an extended period of time, water may accumulate in the fuel tank.

To prevent water condensation.

(1) Top off the fuel tank or drain the fuel completely.

(2) Drain the water condensation from the fuel filter.

- Refilling the fuel tank.

Refill the fuel tank while there is still some fuel left in the tank.

- Protecting the fuel system against freezing and water condensation.

(3) Cold areas

In snow-covered areas, mountainous areas, skiing areas, etc. where ambient temperatures drop below 0°C (32°F) throughout the winter season, use an anti-freeze solution in the cooling system. Refueling will also complement the effect of anti-freeze solution each time the fuel level drops to about one-half. After the winter season, drain the water which may have accumulated in the fuel filter and fuel tank in the manner same as that described under Affected areas below.

(4) Affected areas

When the water condensation is notched in the fuel filter, drain the water from both the fuel filter and fuel tank or use a water removing agent (or anti-freeze solution) in the fuel tank.

- Observe the instructions, notes, etc., indicated on the label affixed to the anti-freeze solution (water removing agent) container before use.