

Brought to you by Eris Studios  
NOT FOR RESALE

# INTAKE (INDUCTION)

# GENERAL DESCRIPTION

INTAKE (INDUCTION)

## 1. General Description

### A: COMPONENT

#### 1. AIR CLEANER

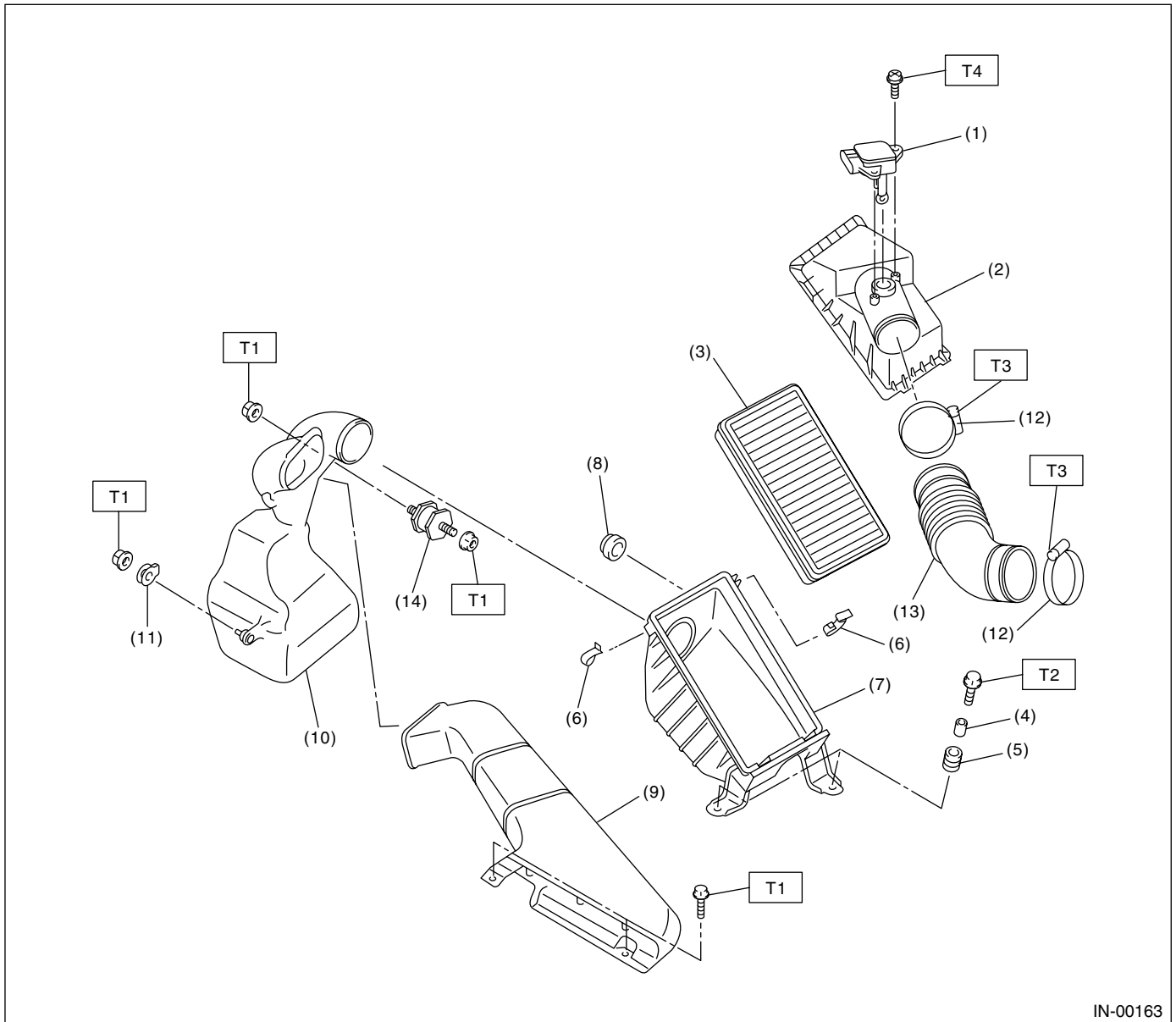

IN-00163

- |   |                             |
|---|-----------------------------|
| (1) Mass air flow and intake air temperature sensor | (8) Cushion rubber          |
| (2) Air cleaner upper cover                         | (9) Air intake duct         |
| (3) Air cleaner element                             | (10) Resonator chamber ASSY |
| (4) Spacer  | (11) Cushion rubber         |
| (5) Bushing   | (12) Clamp                  |
| (6) Clip  | (13) Air intake boot        |
| (7) Air cleaner lower case                          | (14) Cushion                |

**Tightening torque: N-m (kgf-m, ft-lb)**

**T1: 7.5 (0.76, 5.5)**

**T2: 33 (3.4, 24.6)**

**T3: 2.5 (0.25, 1.8)**

**T4: 1.7 (0.17, 1.2)**

# GENERAL DESCRIPTION

INTAKE (INDUCTION)

## 2. INTAKE DUCT

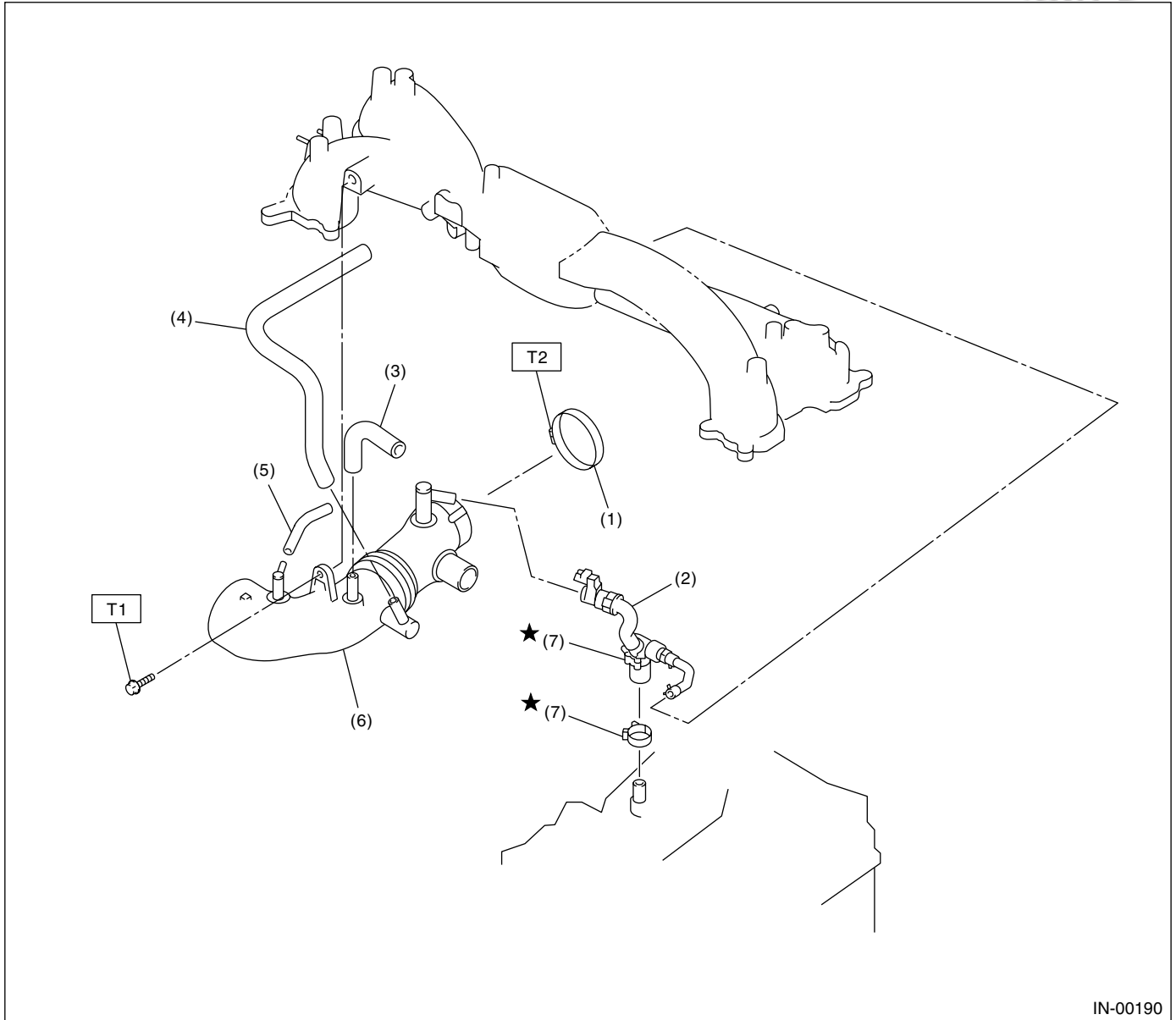

- |                        |                        |
|------------------------|------------------------|
| (1) Clamp              | (5) Air by-pass hose C |
| (2) PCV hose ASSY      | (6) Intake duct        |
| (3) Air by-pass hose A | (7) Clamp              |
| (4) Air by-pass hose B |                        |

**Tightening torque: N-m (kgf-m, ft-lb)**

**T1: 19 (1.9, 13.7)**

**T2: 3 (0.3, 2.2)**

# GENERAL DESCRIPTION

INTAKE (INDUCTION)

## 3. INTERCOOLER

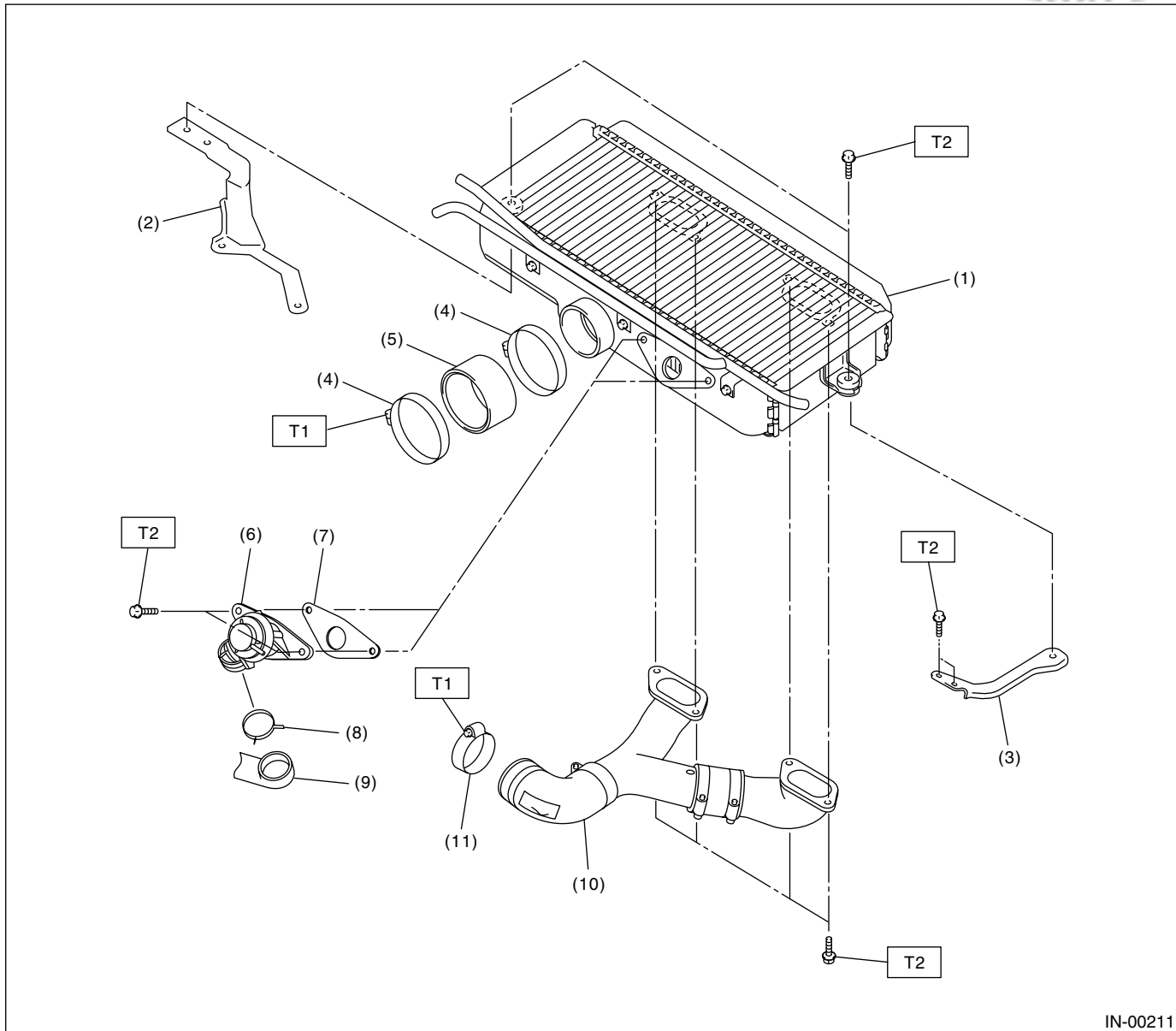

IN-00211

- |                            |                        |            |
|----------------------------|------------------------|------------|
| (1) Intercooler            | (6) Air by-pass valve  | (11) Clamp |
| (2) Intercooler bracket RH | (7) Gasket             |            |
| (3) Intercooler bracket LH | (8) Clamp              |            |
| (4) Clamp                  | (9) Air by-pass hose A |            |
| (5) Air intake duct        | (10) Intercooler duct  |            |

**Tightening torque: N·m (kgf·m, ft·lb)**

**T1: 3 (0.3, 2.2)**

**T2: 16 (1.6, 11.6)**

# GENERAL DESCRIPTION

INTAKE (INDUCTION)

## 4. TURBOCHARGER

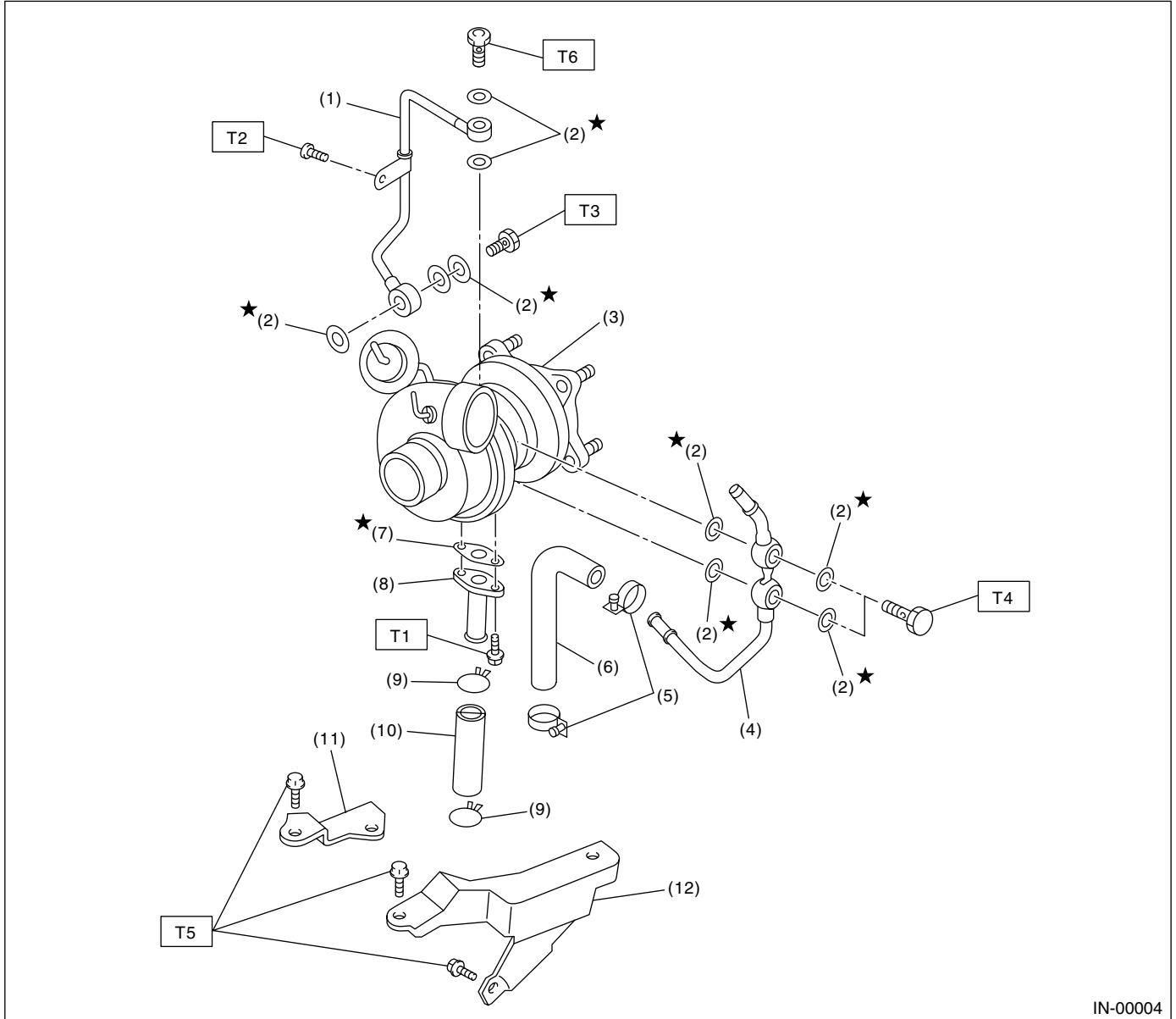

IN-00004

- |                         |                              |
|-------------------------|------------------------------|
| (1) Oil inlet pipe      | (8) Oil outlet pipe          |
| (2) Metal gasket        | (9) Clip                     |
| (3) Turbocharger        | (10) Oil outlet hose         |
| (4) Water pipe          | (11) Turbocharger bracket RH |
| (5) Clamp               | (12) Turbocharger bracket LH |
| (6) Engine coolant hose |                              |
| (7) Gasket              |                              |

**Tightening torque: N-m (kgf-m, ft-lb)**

**T1: 4.4 (0.45, 3.3)**

**T2: 4.9 (0.50, 3.6)**

**T3: 29 (3.0, 21.7)**

**T4: 35 (3.6, 25.8)**

**T5: 33 (3.4, 24.6)**

**T6: 16 (1.6, 11.6)**

# GENERAL DESCRIPTION

INTAKE (INDUCTION)

## 5. INTERCOOLER WATER SPRAY

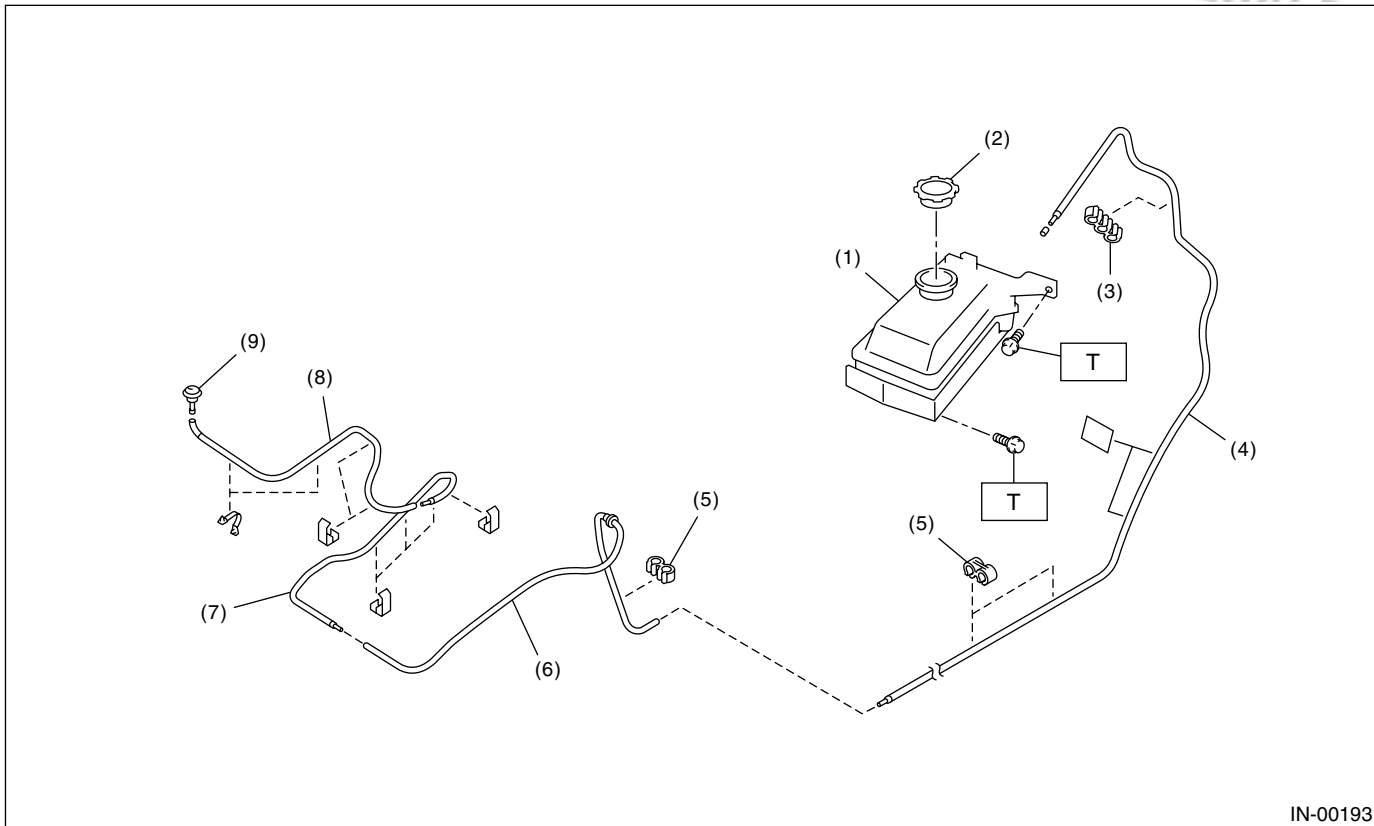

- (1) Water tank ASSY
- (2) Water tank cap
- (3) Clamp
- (4) Rear hose

- (5) Clamp
- (6) Center hose
- (7) Front hose
- (8) Intercooler hose

- (9) Nozzle

**Tightening torque: N·m (kgf·m, ft·lb)**  
**T: 6.0 (0.61, 4.4)**

### **B: CAUTION**

- Wear working clothing, including a cap, protective goggles, and protective shoes during operation.
- Remove contamination including dirt and corrosion before removal, installation or disassembly.
- Keep the disassembled parts in order and protect them from dust or dirt.
- Before removal, installation or disassembly, be sure to clarify the failure. Avoid unnecessary removal, installation, disassembly, and replacement.
- Be careful not to burn your hands, because each part on the vehicle is hot after running.
- Be sure to tighten fasteners including bolts and nuts to the specified torque.
- Place shop jacks or safety stands at the specified points.
- Before disconnecting electrical connectors of sensor or units, be sure to disconnect the ground cable from battery.

# AIR CLEANER

INTAKE (INDUCTION)

## 2. Air Cleaner

### A: REMOVAL

1) Disconnect the ground cable from battery.

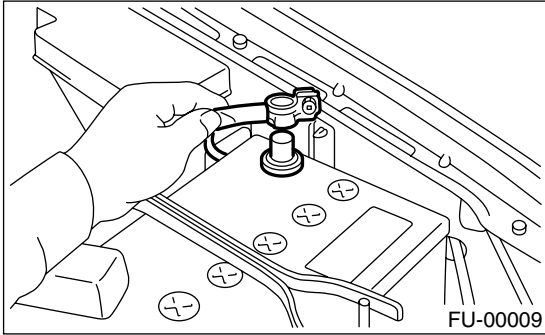

2) Disconnect the connector from mass air flow sensor.

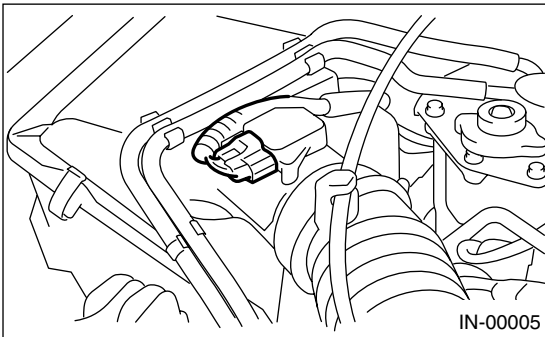

3) Loosen the clamp (A) which connects the air intake boot and intake duct.

4) Remove the clip (B) from air cleaner upper cover.

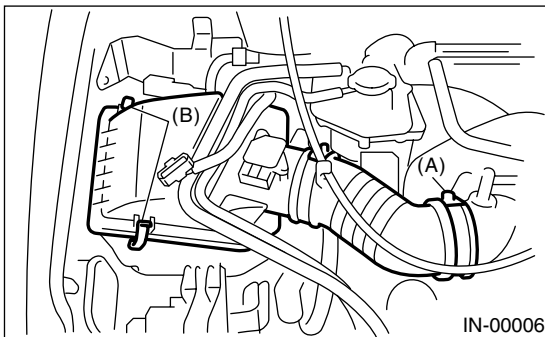

5) Remove the air cleaner upper cover.

6) Remove the air cleaner element.

7) Remove the air cleaner lower case.

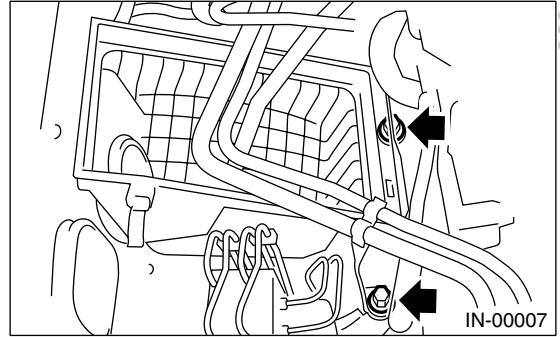

### B: INSTALLATION

Install in the reverse order of removal.

**Tightening torque:**

**33 N·m (3.4 kgf·m, 24.6 ft·lb)**

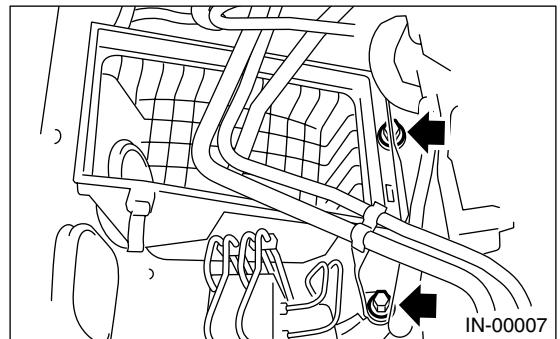

**NOTE:**

Before installing the air cleaner upper cover, align the holes with protruding portions of air cleaner lower case, then secure the upper cover to the lower case.

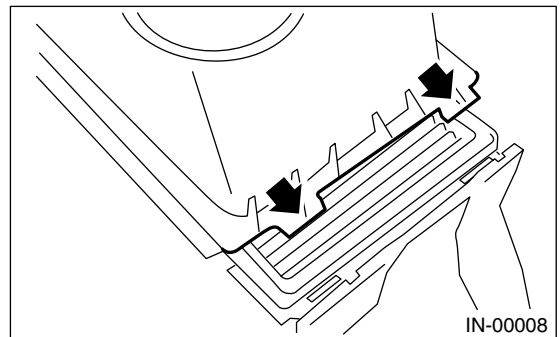

### C: INSPECTION

Replace it if excessively damaged or dirty.



### 3. Air Intake Duct

#### A: REMOVAL

Remove the bolts which install the air intake duct on front side of body.

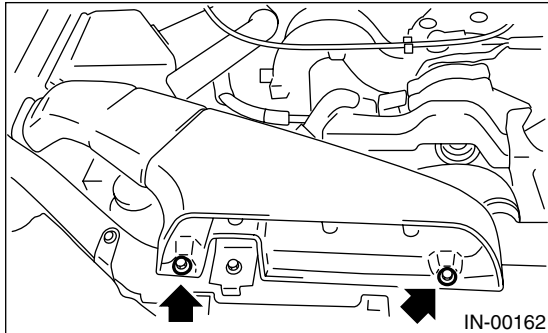

#### B: INSTALLATION

Install in the reverse order of removal.

#### *Tightening torque:*

***7.5 N·m (0.76 kgf-m, 5.5 ft-lb)***

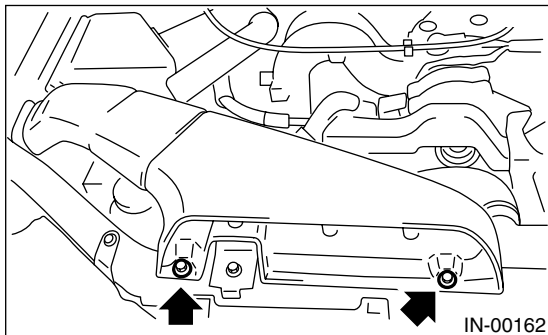

#### C: INSPECTION

- 1) Inspect for cracks and loose connections.
- 2) Inspect that no foreign objects are mixed in air intake duct.

# INTAKE DUCT

INTAKE (INDUCTION)

## 4. Intake Duct

### A: REMOVAL

1) Disconnect the ground cable from battery.

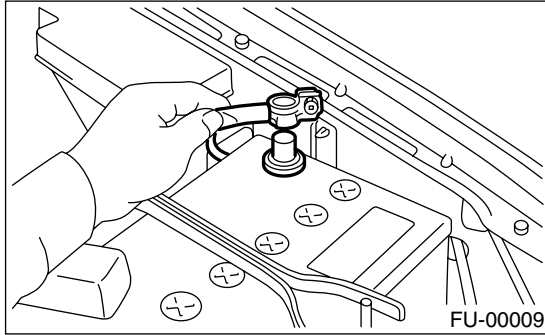

2) Remove the intake manifold. <Ref. to FU(STi)-14, REMOVAL, Intake Manifold.>

3) Remove the sensor, engine harness and fuel pipe attached to intake manifold. <Ref. to FU(STi)-19, DISASSEMBLY, Intake Manifold.>

4) Remove the intake duct from intake manifold.

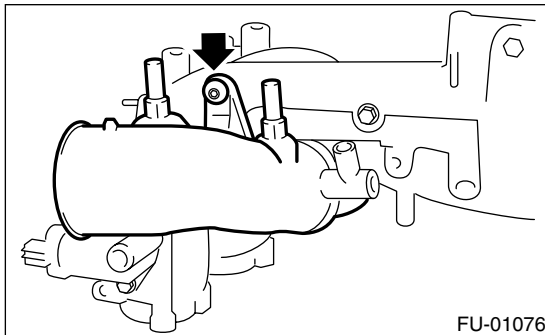

### B: INSTALLATION

Install in the reverse order of removal.

**Tightening torque:**

**19 N·m (1.9 kgf·m, 13.7 ft·lb)**

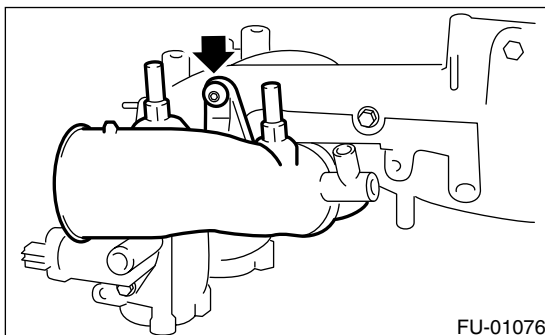

### 5. Intercooler

#### A: REMOVAL

1) Disconnect the air by-pass hoses from intercooler.

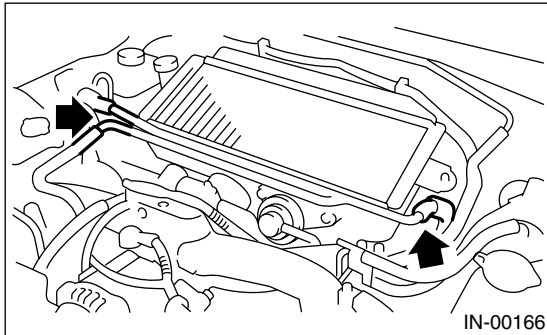

2) Separate the air by-pass valve from intercooler.

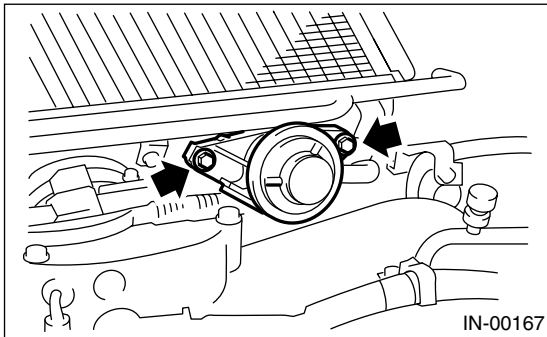

3) Remove the bolts which secure the intercooler to bracket.

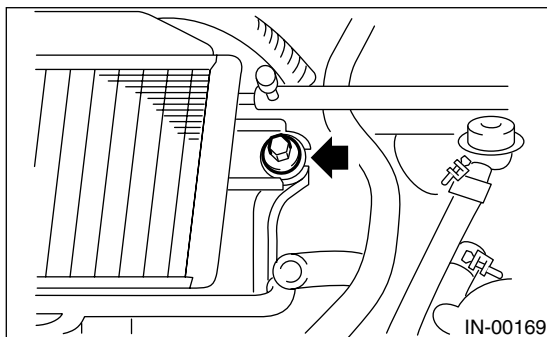
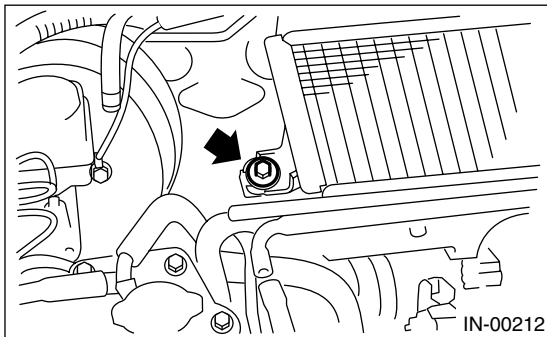

4) Separate the intercooler air duct from turbocharger.

5) Separate the intercooler from throttle body.

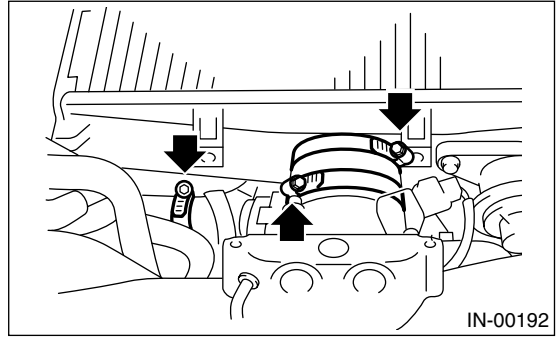

#### B: INSTALLATION

Install in the reverse order of removal.

**Tightening torque:**

**16 N·m (1.6 kgf·m, 11.6 ft·lb)**

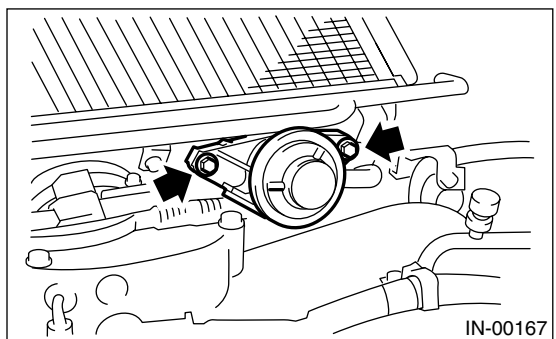
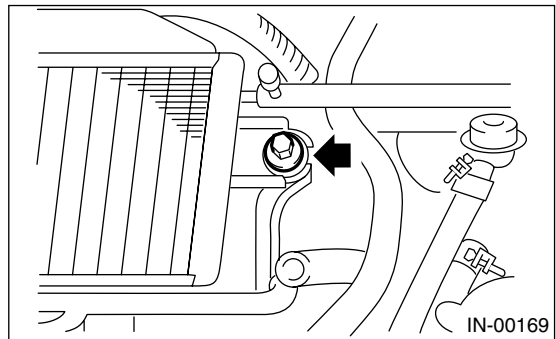
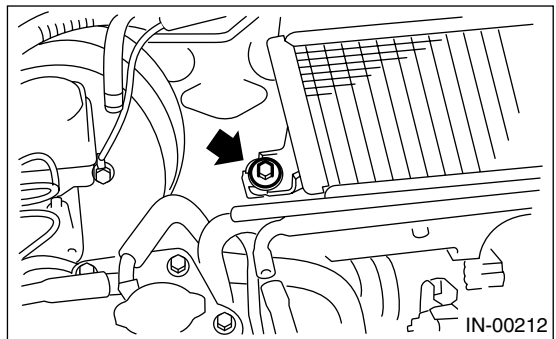

## INTERCOOLER

INTAKE (INDUCTION)

### C: DISASSEMBLY

Remove the intercooler ducts from intercooler.

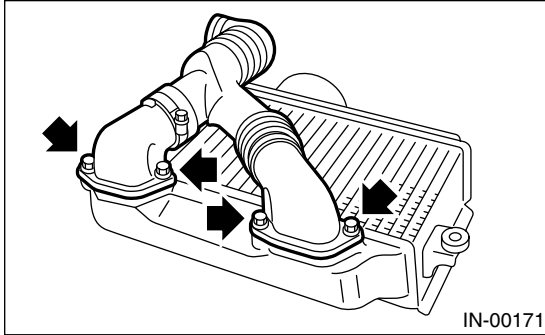

### D: ASSEMBLY

Assemble in the reverse order of disassembly.

*Tightening torque:*

**16 N·m (1.6 kgf-m, 11.7 ft-lb)**

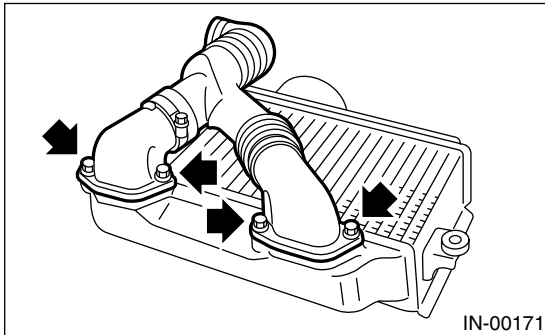

### 6. Turbocharger

#### A: REMOVAL

- 1) Set the vehicle on a lift.
- 2) Disconnect the ground cable from battery.

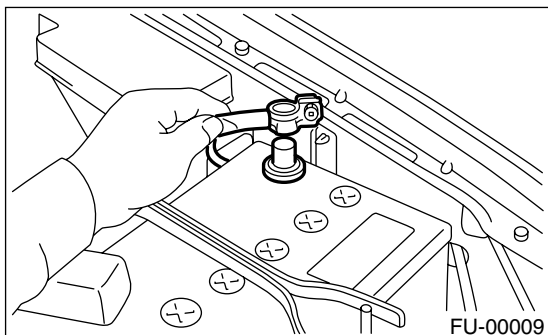

- 3) Remove the center exhaust pipe. <Ref. to EX(H4DOTC)-8, REMOVAL, Center Exhaust Pipe.>
- 4) Lower the vehicle.
- 5) Separate the turbocharger joint pipe from turbocharger.

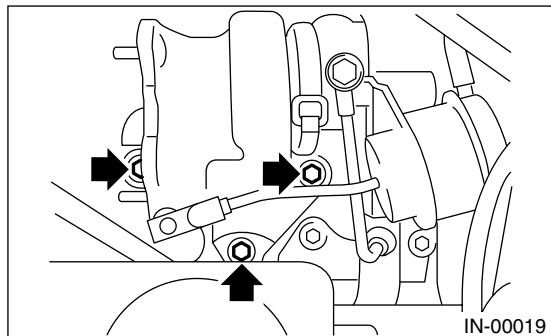

- 6) Disconnect the engine coolant hose which is connected to coolant filler tank.

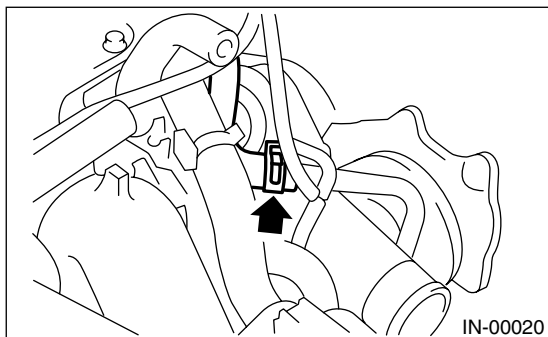

- 7) Loosen the clamp which secures the turbocharger to intake duct.

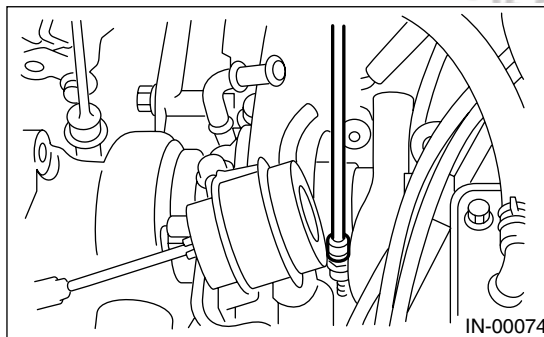

- 8) Remove the bolt which secures the bracket of oil pipe to turbocharger.
- 9) Remove the oil pipe from turbocharger.

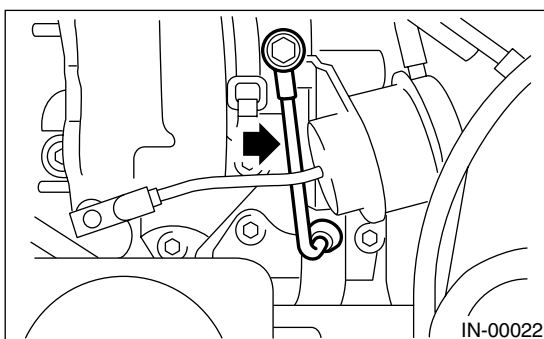

- 10) Disconnect the engine coolant hose.
- 11) Remove the turbocharger bracket.

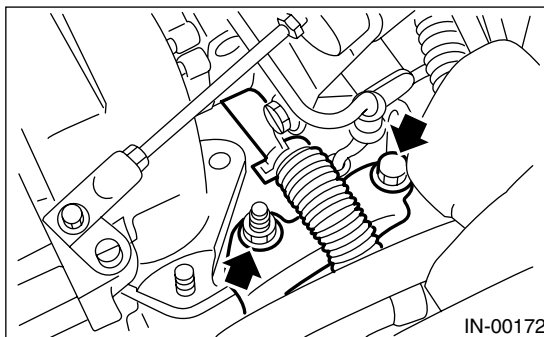

- 12) Disconnect the oil outlet hose from pipe.

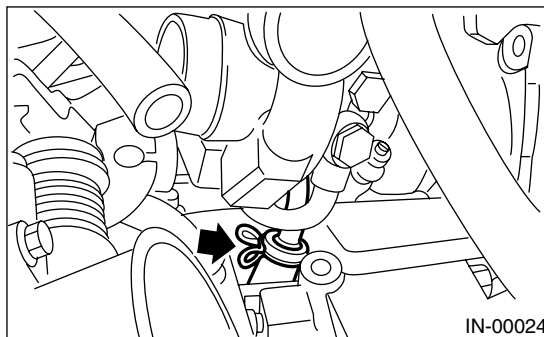

- 13) Take out the turbocharger from engine compartment.

# TURBOCHARGER

## INTAKE (INDUCTION)

### B: INSTALLATION

- 1) Connect the oil outlet hose to outlet pipe.

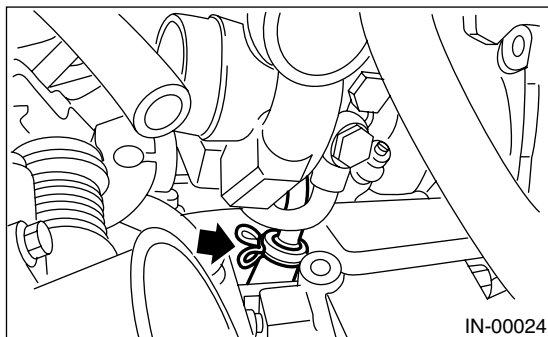

- 2) Install the turbocharger to intake duct.

**Tightening torque:**

**3 N·m (0.3 kgf·m, 2.2 ft·lb)**

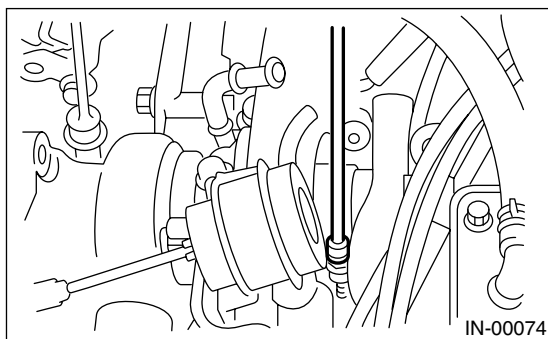

- 3) Install the oil pipe to turbocharger.

**Tightening torque:**

**16 N·m (1.6 kgf·m, 11.6 ft·lb)**

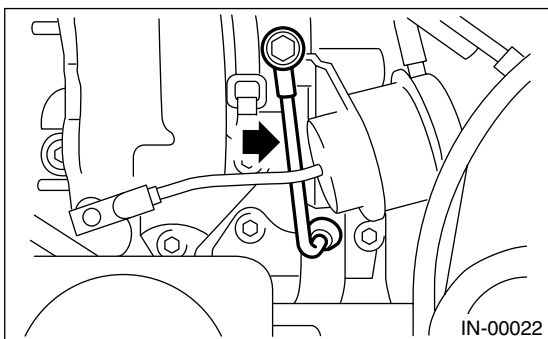

- 4) Install the joint pipe to turbocharger.

**NOTE:**

Replace the gasket with a new one.

**Tightening torque:**

**35 N·m (3.6 kgf·m, 25.8 ft·lb)**

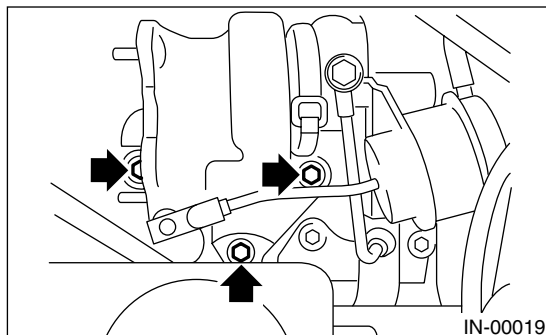

- 5) Connect the engine coolant hose.

- 6) Install the turbocharger bracket.

**Tightening torque:**

**33 N·m (3.4 kgf·m, 24.6 ft·lb)**

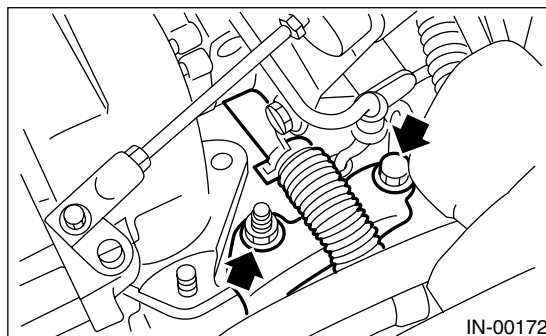

- 7) Connect the engine coolant hose which is connected to coolant filler tank.

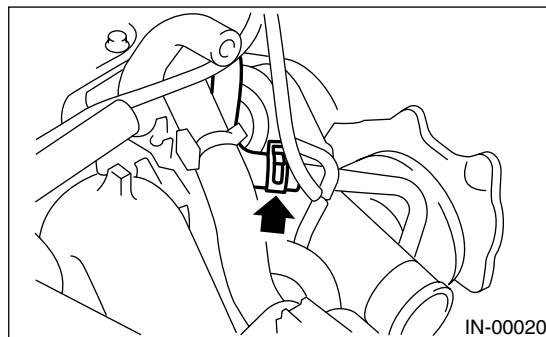

- 8) Lift-up the vehicle.

- 9) Install the center exhaust pipe. <Ref. to EX(H4DOTC)-9, INSTALLATION, Center Exhaust Pipe.>

Brought to you by Eris Studios  
NOT FOR RESALE

## 7. Air By-pass Valve

### A: REMOVAL

1) Remove the air by-pass valve from intercooler.

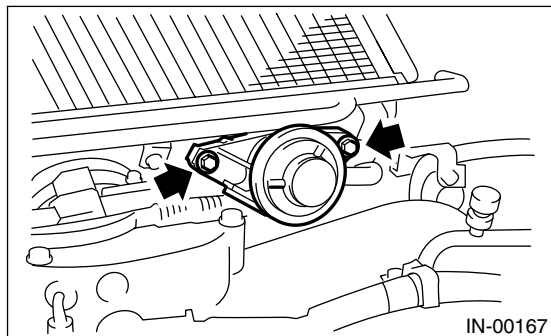

2) Disconnect the air by-pass hoses from air by-pass valve.

### B: INSTALLATION

Install in the reverse order of removal.

**Tightening torque:**

**16 N·m (1.6 kgf·m, 11.6 ft·lb)**

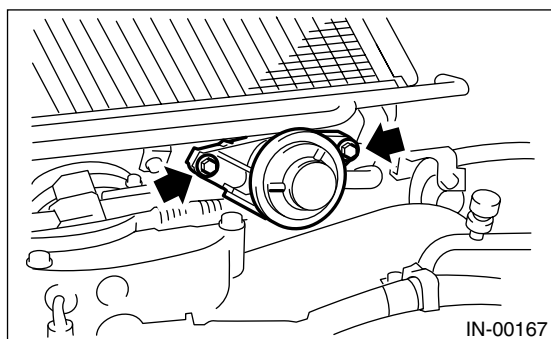

# RESONATOR CHAMBER

INTAKE (INDUCTION)

## 8. Resonator Chamber

### A: REMOVAL

- 1) Set the vehicle on a lift.
- 2) Remove the air intake duct. <Ref. to IN(STi)-9, REMOVAL, Air Intake Duct.>
- 3) Remove the air cleaner lower case. <Ref. to IN(STi)-8, REMOVAL, Air Cleaner.>
- 4) Remove the resonator chamber mounting bolt on right side of engine compartment.

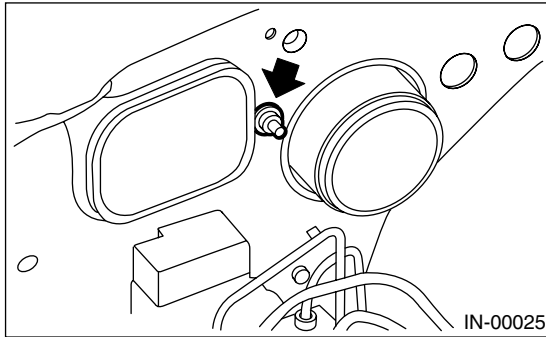

- 5) Remove the front right tire, and lift up the vehicle.
- 6) Remove the front mudguard RH.
- 7) Remove the resonator chamber from the inside front fender.

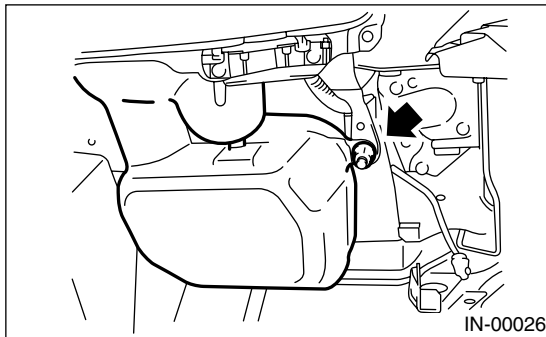

### B: INSTALLATION

Install in the reverse order of removal.

#### *Tightening torque:*

**7.5 N·m (0.76 kgf-m, 5.5 ft-lb)**

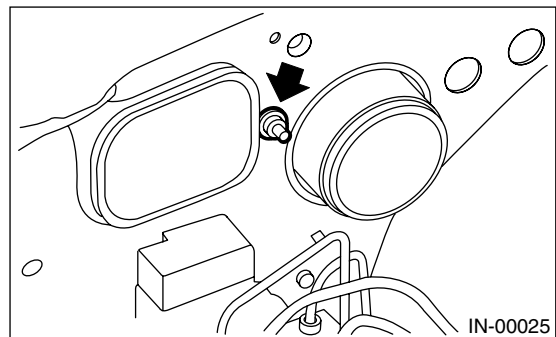
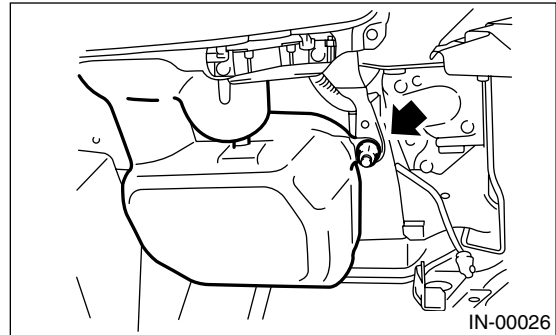

### C: INSPECTION

Inspect for cracks and loose connections. Check that no foreign objects are mixed in resonator chamber.



## 9. Intercooler Water Spray Tank

### A: REMOVAL

- 1) Disconnect the ground cable from battery.

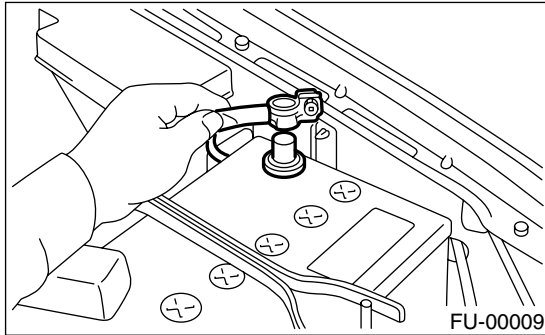

- 2) Remove the trunk trim. <Ref. to EI-55, REMOVAL, Trunk Trim.>
- 3) Disconnect the water tank connector.

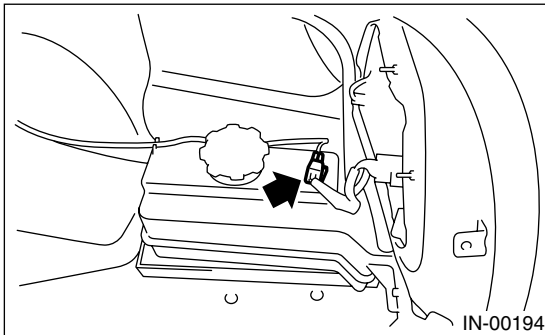

- 4) Remove the two water tank installation bolts.

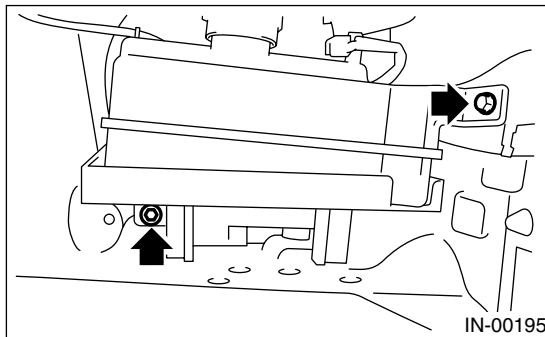

- 5) Remove the hose between body and water tank, then remove the water tank.

### B: INSTALLATION

Install in the reverse order of removal.

#### **Tightening torque:**

**6.0 N·m (0.61 kgf·m, 4.4 ft·lb)**

### C: INSPECTION

- 1) Make sure the hose is not deformed, damaged, cracked or clogged.
- 2) Make sure the water tank is not damaged or cracked

# INTERCOOLER WATER SPRAY NOZZLE

INTAKE (INDUCTION)

## 10. Intercooler Water Spray Nozzle

### A: REMOVAL

- 1) Open the front hood.
- 2) Disconnect the connecting part of hose.
- 3) Push the clip of nozzle upward with the clip pressed by fingers from inside of front hood.

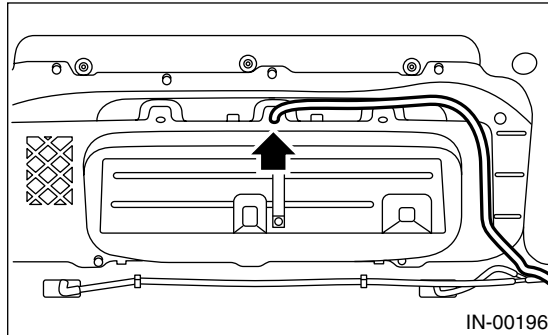

### B: INSTALLATION

Install in the reverse order of removal.

### C: INSPECTION

Make sure the hose and nozzle are not deformed, damaged, cracked or clogged.