

Brought to you by Eris Studios  
NOT FOR RESALE

# LUBRICATION

# GENERAL DESCRIPTION

## LUBRICATION

### 1. General Description

#### A: SPECIFICATIONS

Lubrication method			Forced lubrication	
Oil pump	Pump type		Trochoid type	
	Number of teeth	Inner rotor	9	
		Outer rotor	10	
	Outer rotor diameter × thickness		78 × 10 mm (3.07 × 0.39 in)	
	Tip clearance between inner and outer rotor	STANDARD	0.04 — 0.14 mm (0.0016 — 0.0055 in)	
		LIMIT	0.18 mm (0.0071 in)	
	Side clearance between inner rotor and pump case	STANDARD	0.02 — 0.07 mm (0.0008 — 0.0028 in)	
		LIMIT	0.12 mm (0.0047 in)	
	Case clearance between outer rotor and pump case	STANDARD	0.10 — 0.175 mm (0.0039 — 0.0069 in)	
		LIMIT	0.20 mm (0.0079 in)	
	Capacity at 80°C (176°F)	600 rpm	Discharge pressure	98 kPa (1.0 kg/cm <sup>2</sup> , 14 psi)
			Discharge quantity	4.6 ℓ (4.9 US qt, 4.0 Imp qt)/min.
5,000 rpm		Discharge pressure	294 kPa (3.0 kg/cm <sup>2</sup> , 43 psi)	
		Discharge quantity	47.0 ℓ (49.7 US qt, 41.4 Imp qt)/min.	
Relief valve operation pressure			588 kPa (6.0 kg/cm <sup>2</sup> , 85 psi)	
Oil filter	Type		Full-flow filter type	
	Filtration area		800 cm <sup>2</sup> (124 sq in)	
	By-pass valve opening pressure		160 kPa (1.63 kg/cm <sup>2</sup> , 23.2 psi)	
	Outer diameter × width		68 × 65 mm (2.68 × 2.56 in)	
	Oil filter to engine thread size		M 20 × 1.5	
Oil pressure switch	Type		Immersed contact point type	
	Working voltage — wattage		12 V — 3.4 W or less	
	Warning light activation pressure		14.7 kPa (0.15 kg/cm <sup>2</sup> , 2.1 psi)	
	Proof pressure		More than 981 kPa (10 kg/cm <sup>2</sup> , 142 psi)	
Oil capacity (at replacement)			4.5 ℓ (4.8 US qt, 4.0 Imp qt)	

**B: COMPONENT**

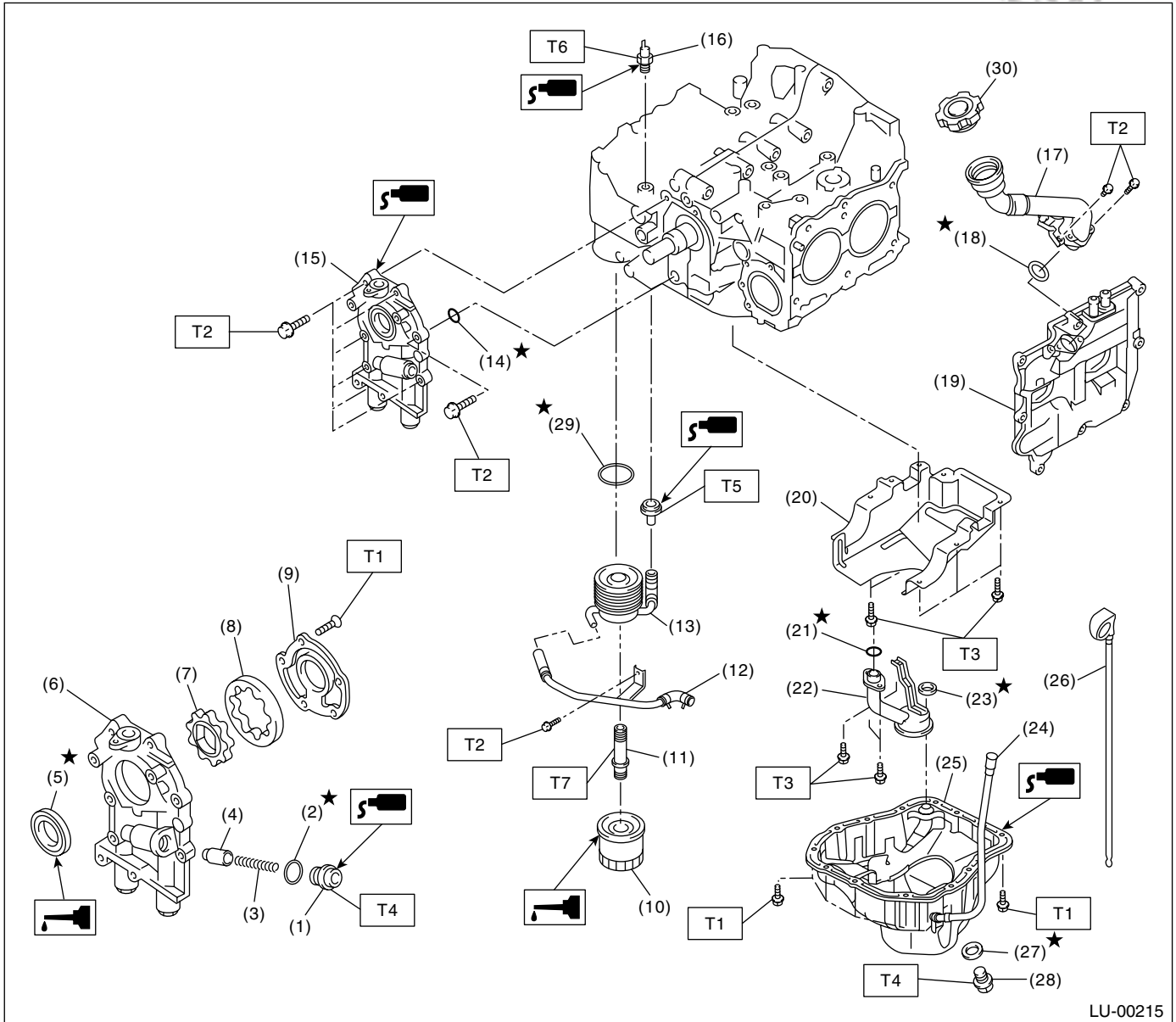

LU-00215

- |                           |                            |                     |
|---------------------------|----------------------------|---------------------|
| (1) Plug                  | (14) O-ring                | (27) Metal gasket   |
| (2) Gasket                | (15) Oil pump ASSY         | (28) Drain plug     |
| (3) Relief valve spring   | (16) Oil pressure switch   | (29) O-ring         |
| (4) Relief valve          | (17) Oil filler duct       | (30) Oil filler cap |
| (5) Oil seal              | (18) O-ring                |                     |
| (6) Oil pump case         | (19) Rocker cover          |                     |
| (7) Inner rotor           | (20) Baffle plate          |                     |
| (8) Outer rotor           | (21) O-ring                |                     |
| (9) Oil pump cover        | (22) Oil strainer          |                     |
| (10) Oil filter           | (23) Gasket                |                     |
| (11) Oil cooler connector | (24) Oil level gauge guide |                     |
| (12) Water by-pass pipe   | (25) Oil pan               |                     |
| (13) Oil cooler           | (26) Oil level gauge       |                     |
|                           |                            |                     |
|                           |                            |                     |
|                           |                            |                     |
|                           |                            |                     |
|                           |                            |                     |

**Tightening torque: N·m (kgf·m, ft·lb)**

**T1: 5 (0.5, 3.6)**

**T2: 6.4 (0.65, 4.7)**

**T3: 10 (1.0, 7.0)**

**T4: 44 (4.5, 32.5)**

**T5: 69 (7.0, 50.9)**

**T6: 25 (2.5, 18.1)**

**T7: 54 (5.5, 40)**

#### **C: CAUTION**

- Wear working clothing, including a cap, protective goggles, and protective shoes during operation.
- Remove contamination including dirt and corrosion before removal, installation or disassembly.
- Keep the disassembled parts in order and protect them from dust or dirt.
- Before removal, installation or disassembly, be sure to clarify the failure. Avoid unnecessary removal, installation, disassembly, and replacement.
- Be careful not to burn your hands, because each part in the vehicle is hot after running.
- Be sure to tighten fasteners including bolts and nuts to the specified torque.
- Place shop jacks or safety stands at the specified points.
- Before disconnecting electrical connectors of sensors or units, be sure to disconnect the ground cable from battery.

**D: PREPARATION TOOL**

**1. SPECIAL TOOLS**

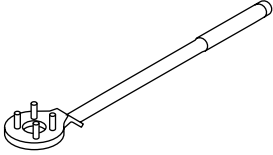
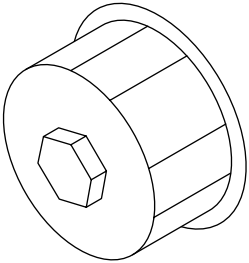
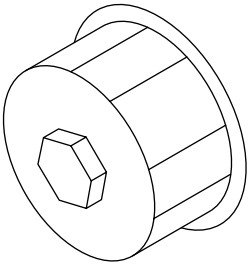
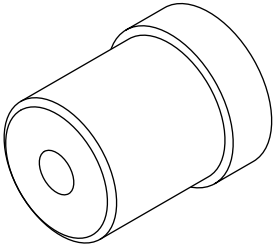
ILLUSTRATION	TOOL NUMBER	DESCRIPTION	REMARKS
 <p data-bbox="386 653 521 674">ST-499977100</p>	499977100	CRANKSHAFT PULLEY WRENCH	Used for stopping rotation of crankshaft pulley when loosening and tightening crankshaft pulley bolt.
 <p data-bbox="380 1024 521 1045">ST18332AA000</p>	18332AA000	OIL FILTER WRENCH	Used for removing and installing oil filter. (Outer diameter: 68 mm (2.68 in))
 <p data-bbox="380 1396 521 1417">ST18332AA010</p>	18332AA010	OIL FILTER WRENCH	Used for removing and installing oil filter. (Outer diameter: 65 mm (2.56 in))
 <p data-bbox="386 1770 521 1791">ST-499587100</p>	499587100	OIL SEAL INSTALLER	Used for installing oil seal to oil pump.

# OIL PRESSURE SYSTEM

LUBRICATION

## 2. Oil Pressure System

### A: SCHEMATIC

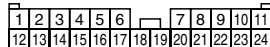
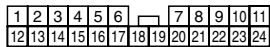
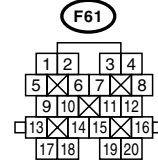
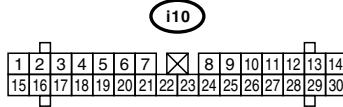
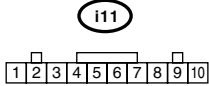
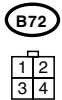
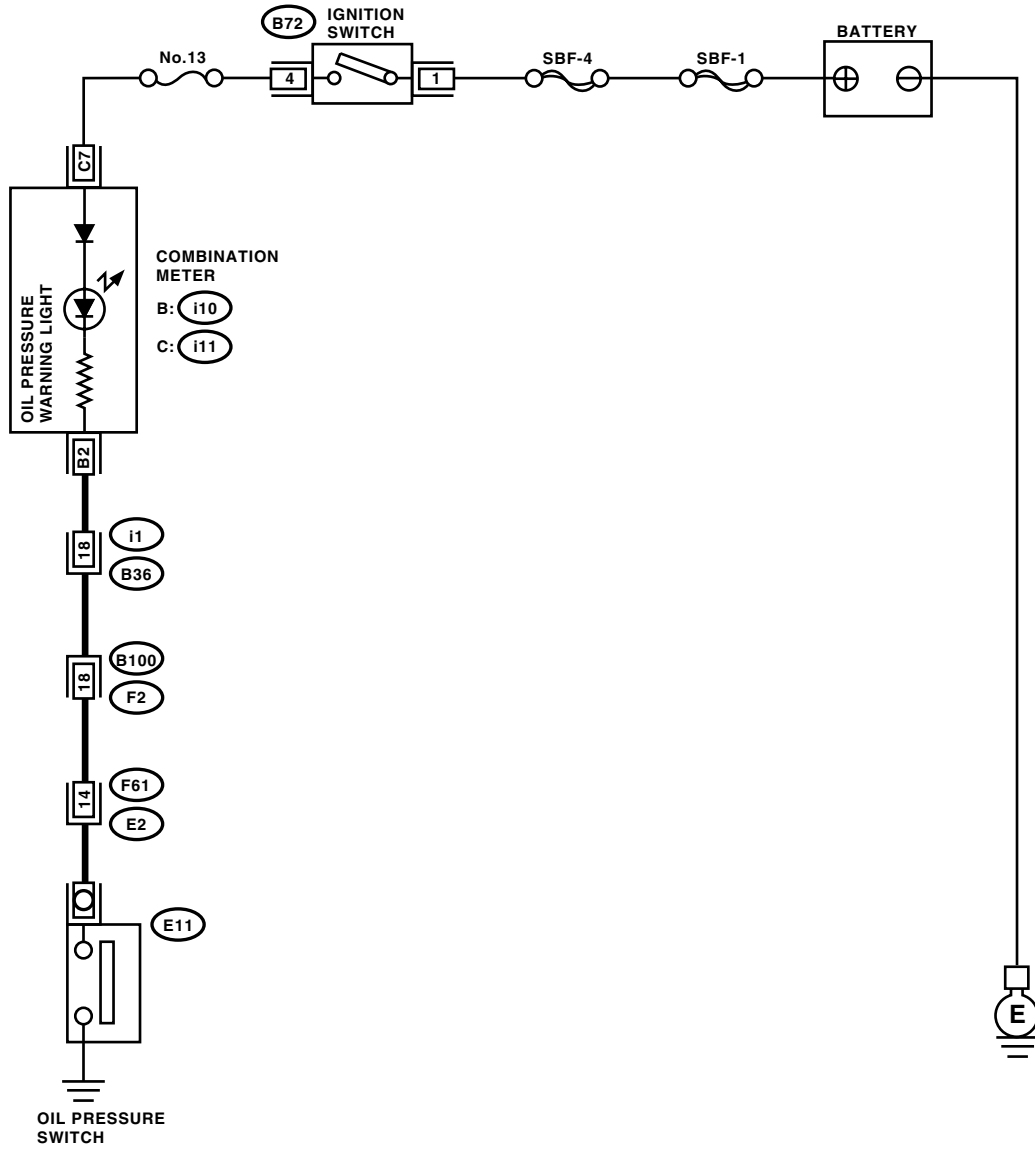

LU-00212

## B: INSPECTION

Step	Check	Yes	No
<b>1 CHECK COMBINATION METER.</b> 1) Turn the ignition switch to ON. (engine OFF) 2) Check other warning lights.	Does the warning lights go on?	Go to step 2.	Repair or replace the combination meter. <Ref. to IDI-3, INSPECTION, Combination Meter System.>
<b>2 CHECK HARNESS CONNECTOR BETWEEN COMBINATION METER AND OIL PRESSURE SWITCH.</b> 1) Turn the ignition switch to OFF. 2) Disconnect the connector from oil pressure switch. 3) Turn the ignition switch ON. 4) Measure the voltage of harness between the combination meter connector and chassis ground. <i>Connector &amp; terminal</i> <i>(E11) No. 1 (+) — Chassis ground (-):</i>	Is the voltage more than 10 V?	Replace the oil pressure switch.	Go to step 3.
<b>3 CHECK COMBINATION METER.</b> 1) Turn the ignition switch to OFF. 2) Remove the combination meter. 3) Measure the resistance of combination meter. <i>Terminals</i> <i>No. C7 — No. B2:</i>	Is the resistance less than 10 Ω?	Replace the harness connector between combination meter and oil pressure switch.	Repair or replace the combination meter.

## 3. Engine Oil

### A: INSPECTION

- 1) Park the vehicle on a level surface.
- 2) Remove the oil level gauge and wipe it clean.
- 3) Reinsert the level gauge all the way. Be sure that the level gauge is correctly inserted and in proper orientation.
- 4) Remove it again and note the reading. If the engine oil level is below the "L" line, add oil to bring the level up to "F" line.
- 5) After turning off the engine, wait a few minutes for oil to drain back into the oil pan before checking the level.
- 6) Just after driving or while the engine is warm, engine oil level may show in the range between the "F" line and notch mark. This is caused by thermal expansion of engine oil.

#### NOTE:

To prevent overfilling the engine oil, do not add oil above "F" line when the engine is cold.

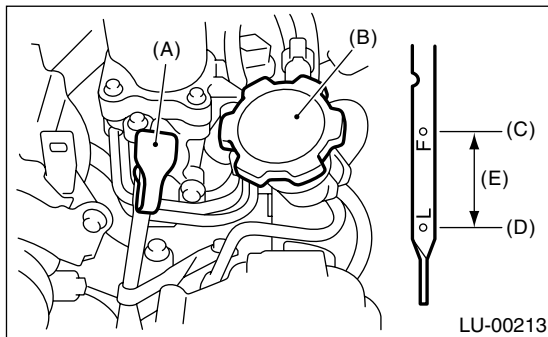

- (A) Oil level gauge
- (B) Engine oil filler cap
- (C) Upper level
- (D) Lower level
- (E) Approx. 1.0 ℓ (1.1 US qt, 0.9 Imp qt)

### B: REPLACEMENT

- 1) Open the engine oil filler cap for quick draining of engine oil.
- 2) Drain the engine oil by loosening the engine oil drain plug.

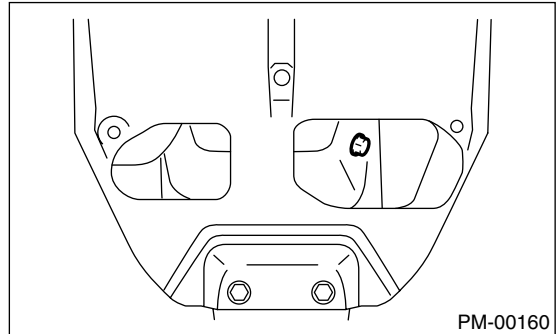

- 3) Replace the drain plug gasket.
- 4) Tighten the engine oil drain plug after draining engine oil.

#### Tightening torque:

**44 N·m (4.5 kgf·m, 32.5 ft·lb)**

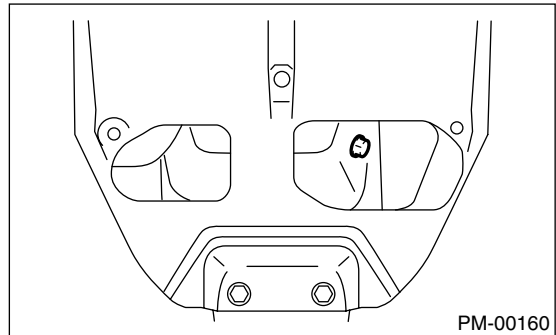

- 5) Install the service hole cover.
- 6) Fill engine oil through the filler pipe up to upper level on level gauge. Make sure that the vehicle is placed level when checking oil level. Use the engine oil of proper quality and viscosity, selected in accordance with the table in figure.



**Recommended oil**

**ILSAC GF-3, which can be identified with the new API certification mark (Star burst mark) API classification SL with the words "ENERGY CONSERVING" (if you cannot obtain the oil with SL grade, you may use SJ grade "ENERGY CONSERVING" oil)**

**Engine oil capacity:**

**Upper level**

**4.5 ℓ (4.8 US qt, 4.0 Imp qt)**

**Lower level**

**3.5 ℓ (3.7 US qt, 3.1 Imp qt)**

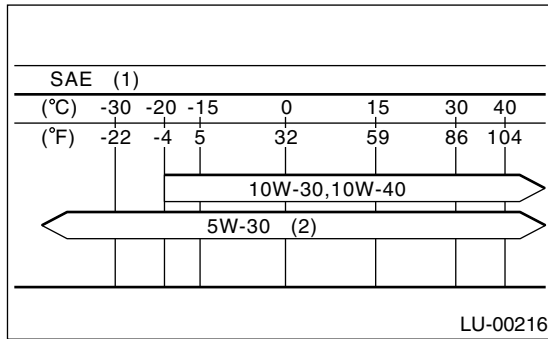

- (1) SAE Viscosity No. and Applicable Temperature
- (2) PREFERRED

The proper viscosity helps vehicle get good cold and hot starting by reducing viscous friction and thus increasing cranking speed.

**CAUTION:**

**When replenishing oil, it does not matter if the oil to be added is a different brand from that in the engine; however, use oil having the API classification and SAE viscosity No. designated by SUBARU.**

**NOTE:**

If the vehicle is used in areas with very high temperatures or for other heavy duty applications, the following viscosity oils may be used: API classification: SL or SJ or SH  
SAE Viscosity No.: 30, 40, 10W-50, 20W-40, 20W-50.

- 7) Close the engine oil filler cap.
- 8) Start the engine and warm it up for a time.

9) After the engine stops, recheck the oil level. If necessary, add engine oil up to the upper level on level gauge.

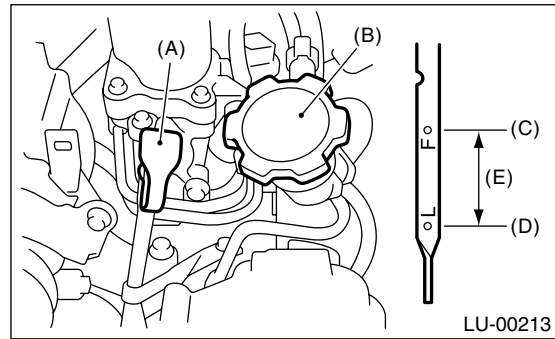

- (A) Oil level gauge
- (B) Engine oil filler cap
- (C) Upper level
- (D) Lower level
- (E) Approx. 1.0 ℓ (1.1 US qt, 0.9 Imp qt)

## 4. Oil Pump

### A: REMOVAL

1) Disconnect the ground cable from battery.

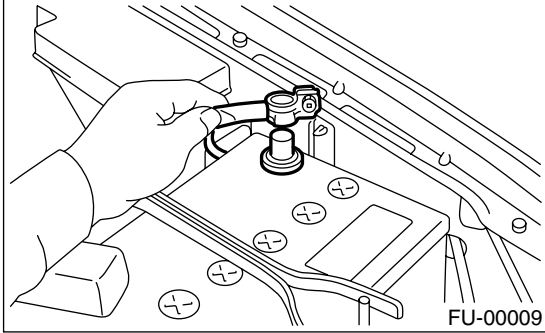

2) Lift-up the vehicle.

3) Remove the under cover.

4) Remove the bolts which install the water pipe of oil cooler to oil pump.

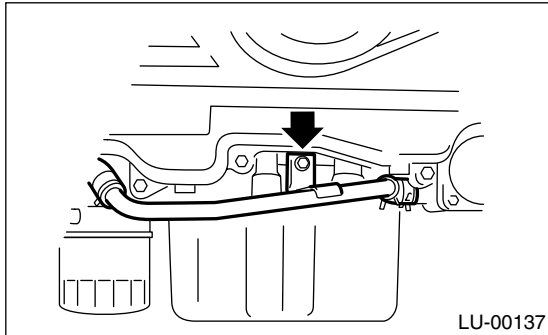

5) Remove the water pipe and hoses between oil cooler and water pump.

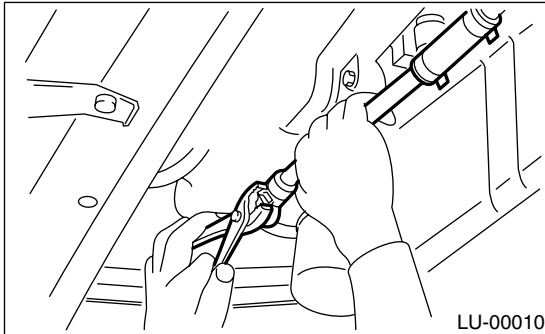

6) Remove the radiator. <Ref. to CO(H4DOTC)-22, REMOVAL, Radiator.>

7) Remove the crankshaft position sensor.

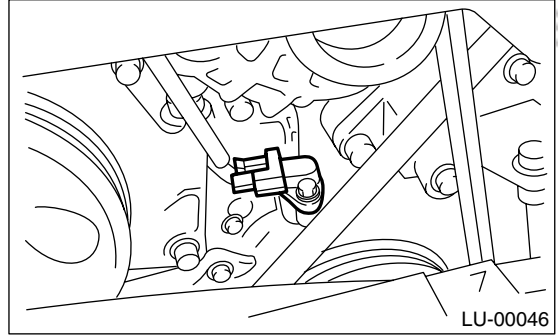

8) Remove the V-belts.

<Ref. to ME(STi)-41, REMOVAL, V-belt.>

9) Remove the rear side V-belt tensioner.

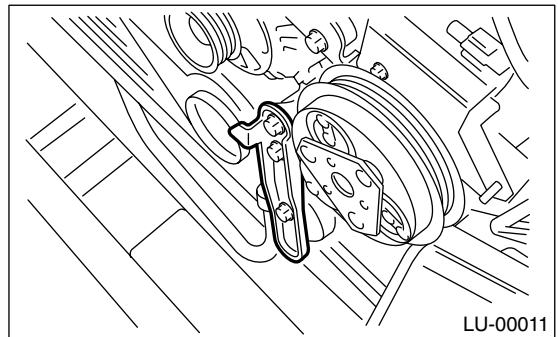

10) Remove the crankshaft pulley by using ST. <Ref. to ME(STi)-44, REMOVAL, Crankshaft Pulley.>

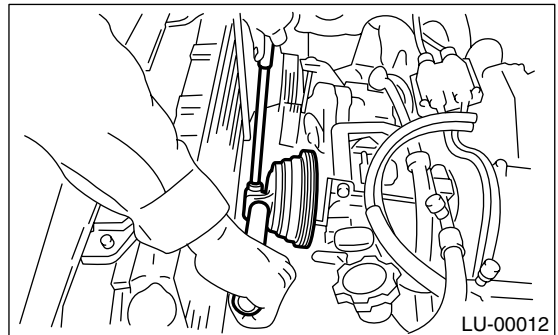

11) Remove the water pump. <Ref. to CO(H4DOTC)-19, REMOVAL, Water Pump.>

12) Remove the timing belt guide.

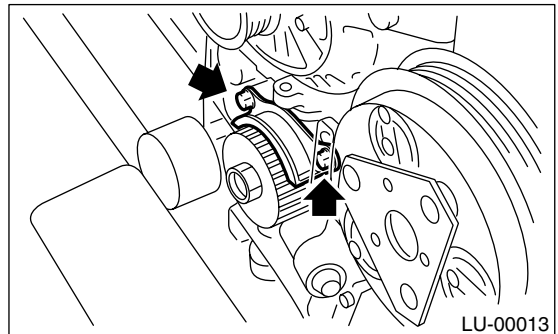

13) Remove the crankshaft sprocket.

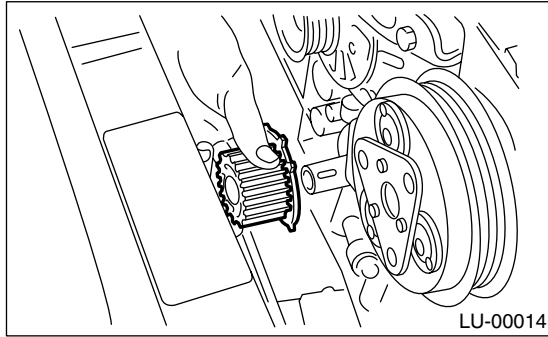

14) Remove the bolts which install the oil pump onto cylinder block.

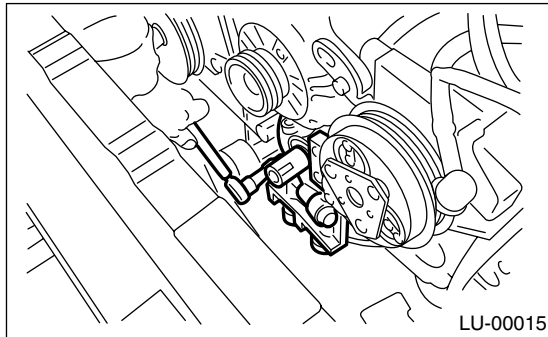

15) Remove the oil pump using the flat tip screwdriver.

**CAUTION:**

**Be careful not to scratch the mating surfaces of cylinder block and oil pump.**

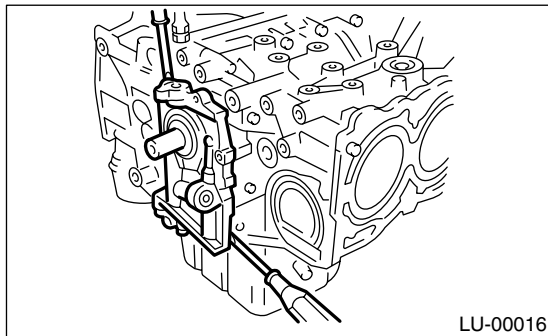

## B: INSTALLATION

Install in the reverse order of removal.

Do the following:

- 1) Apply fluid packing to the matching surfaces of oil pump.

**Fluid packing:**

**THREE BOND 1215 (Part No. 004403007) or equivalent**

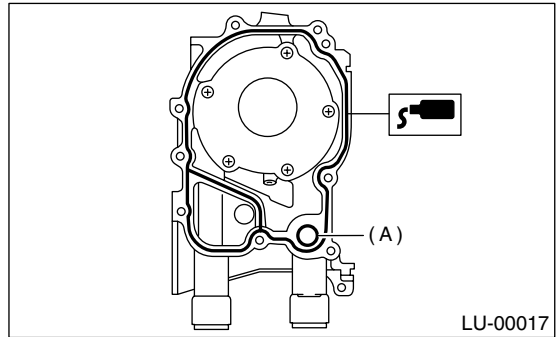

- 2) Replace the O-ring (A) with a new one.
- 3) Apply a coat of engine oil to the inside of oil seal.

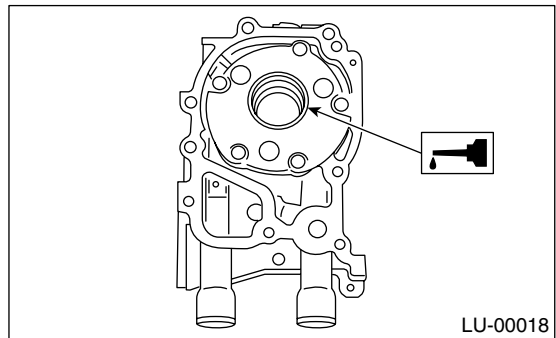

- 4) Be careful not to scratch the oil seal when installing the oil pump on cylinder block.
- 5) Position the oil pump, aligning the notched area with crankshaft, and push the oil pump straight.

**CAUTION:**

**Make sure the oil seal lip is not folded.**

- 6) Install the oil pump.

**Tightening torque:**

**6.4 N·m (0.65 kgf·m, 4.7 ft·lb)**

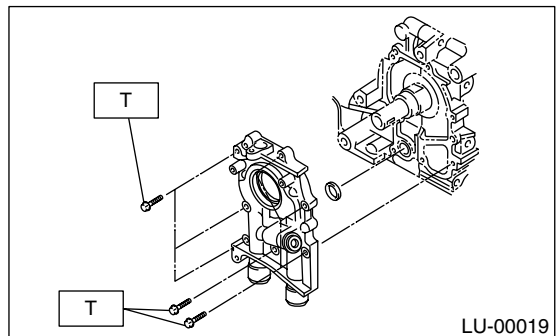

# OIL PUMP

## LUBRICATION

### C: DISASSEMBLY

Remove the screws which secure the oil pump cover and disassemble oil pump. Inscribe alignment marks on the inner and outer rotors so that they can be replaced in their original positions during reassembly.

#### CAUTION:

**Before disassembling the oil pump, remove the relief valve.**

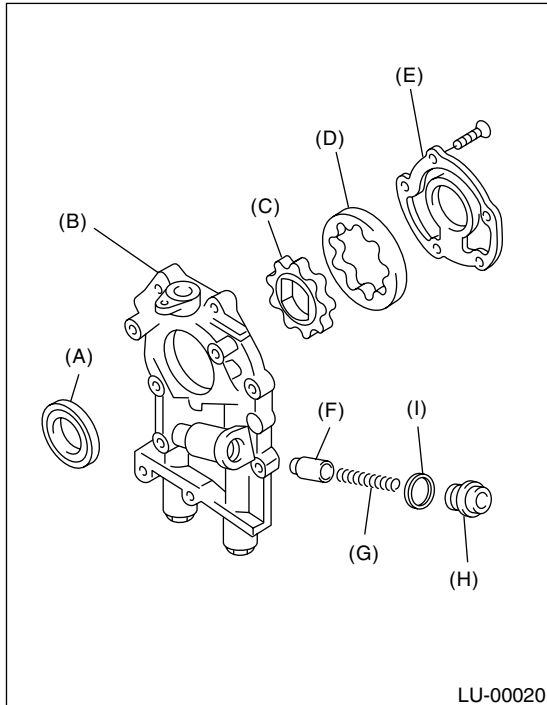

- (A) Oil seal
- (B) Pump case
- (C) Inner rotor
- (D) Outer rotor
- (E) Pump cover
- (F) Relief valve
- (G) Relief valve spring
- (H) Plug
- (I) Gasket

### D: ASSEMBLY

1) Install the front oil seal by using ST.  
ST 499587100 OIL SEAL INSTALLER

#### NOTE:

Use a new oil seal.

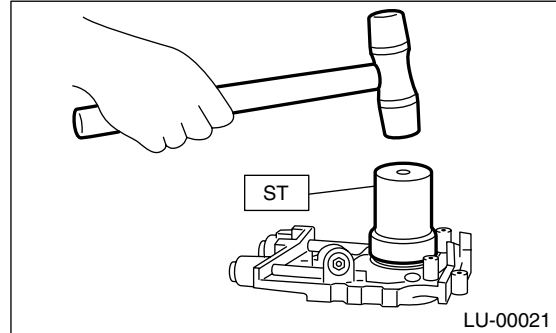

2) Apply a coat of engine oil to the inner and outer rotors.

3) Install the inner and outer rotors in their original positions.

4) Install the oil relief valve, relief valve spring and plug.

#### NOTE:

Use a new gasket.

5) Install the oil pump cover.

#### Tightening torque:

**T1: 5 N·m (0.5 kgf-m, 3.6 ft-lb)**

**T2: 44 N·m (4.5 kgf-m, 32.5 ft-lb)**

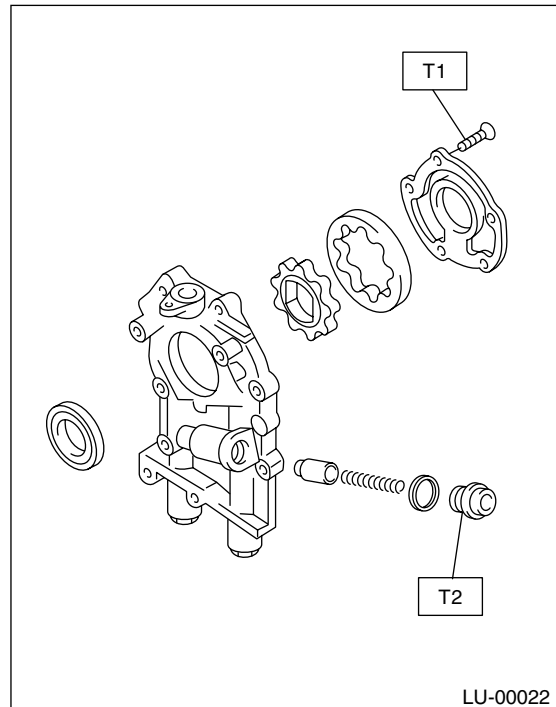

**E: INSPECTION****1. TIP CLEARANCE**

Measure the tip clearance of rotors. If clearance exceeds the limit, replace the rotors as a matched set.

**Tip clearance:****Standard**

**0.04 — 0.14 mm (0.0016 — 0.0055 in)**

**Limit**

**0.18 mm (0.0071 in)**

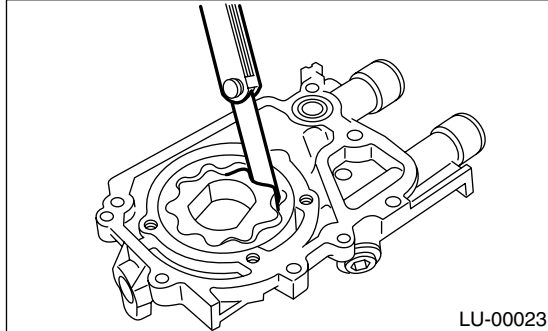

LU-00023

**2. CASE CLEARANCE**

Measure the clearance between outer rotor and oil pump rotor housing. If clearance exceeds the limit, replace the rotor.

**Case clearance:****Standard**

**0.10 — 0.175 mm (0.0039 — 0.0069 in)**

**Limit**

**0.20 mm (0.0079 in)**

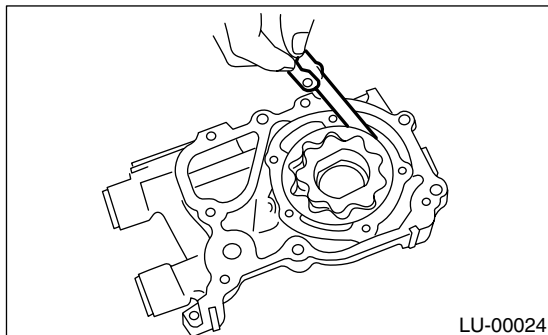

LU-00024

**3. SIDE CLEARANCE**

Measure the clearance between the oil pump inner rotor and pump cover. If clearance exceeds the limit, replace the rotor or pump body.

**Side clearance:****Standard**

**0.02 — 0.07 mm (0.0008 — 0.0028 in)**

**Limit**

**0.12 mm (0.0047 in)**

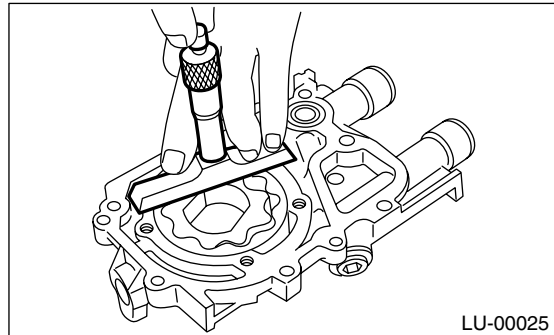

LU-00025

**4. OIL RELIEF VALVE**

Check the valve for fitting condition and damage, and the relief valve spring for damage and deterioration. Replace the parts if defective.

**Relief valve spring:****Free length**

**73.7 mm (2.902 in)**

**Installed length**

**54.7 mm (2.154 in)**

**Load when installed**

**93.1 N (9.49 kgf, 20.88 lb)**

**5. OIL PUMP CASE**

Check the oil pump case for worn shaft hole, clogged oil passage, worn rotor chamber, cracks, and other faults.

**6. OIL SEAL**

Check the oil seal lips for deformation, hardening, wear, etc. and replace if defective.

## 5. Oil Pan and Strainer

### A: REMOVAL

- 1) Set the vehicle on a lift.
- 2) Remove the front wheels.
- 3) Disconnect the ground cable from battery.

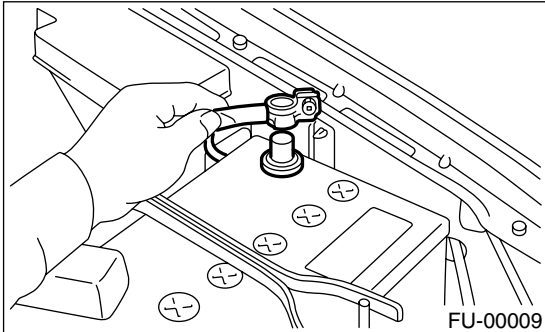

- 4) Disconnect the connector from mass air flow sensor.

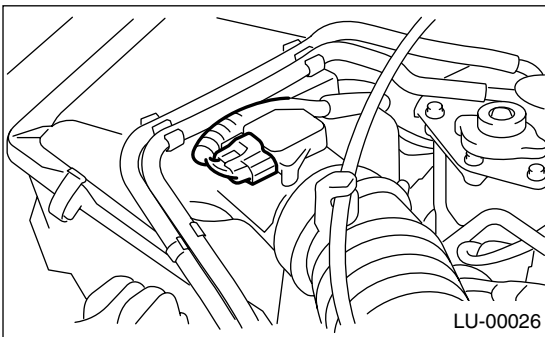

- 5) Remove the air intake boot and air cleaner upper cover.

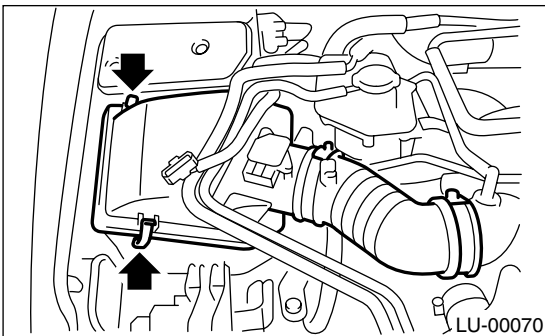

- 6) Remove the intercooler. <Ref. to IN(H4DOTC)-10, REMOVAL, Intercooler.>

- 7) Remove the pitching stopper.

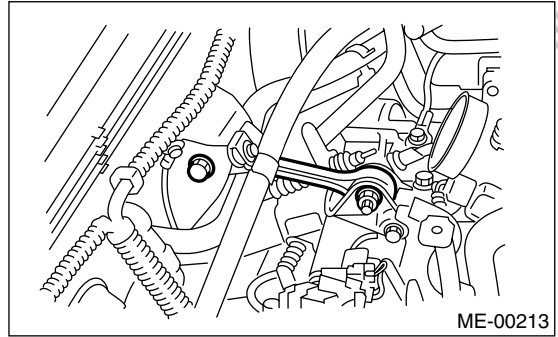

- 8) Remove the radiator upper brackets.

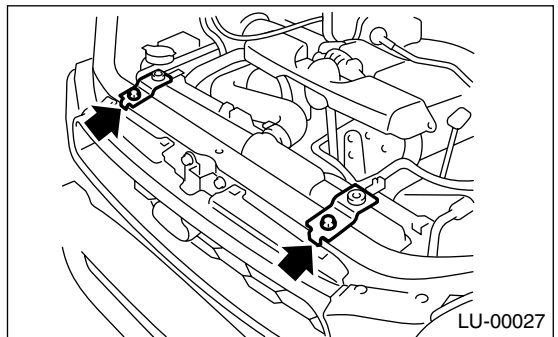

- 9) Support the engine with a lifting device and wire ropes.

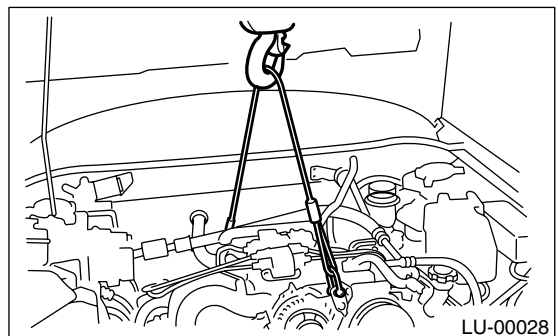

- 10) Lift-up the vehicle.

**CAUTION:**  
When lifting up the vehicle, rise up the wire rope together.

- 11) Remove the under cover.
- 12) Drain the engine oil.

13) Remove the nuts which install the front cushion rubber onto front crossmember.

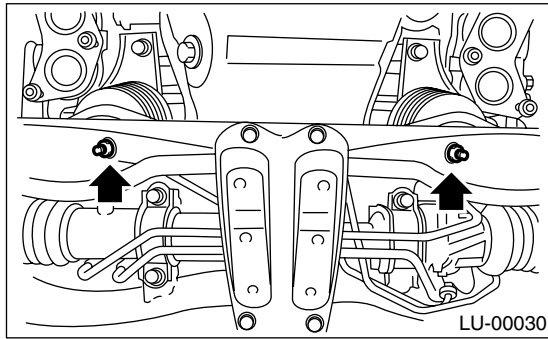

14) Remove the bolts which install the oil pan on cylinder block while raising up engine.

15) Insert the oil pan cutter blade between cylinder block-to-oil pan clearance.

**CAUTION:**  
Do not use a screwdriver or similar tool in place of oil pan cutter.

16) Remove the oil strainer.

17) Remove the baffle plate.

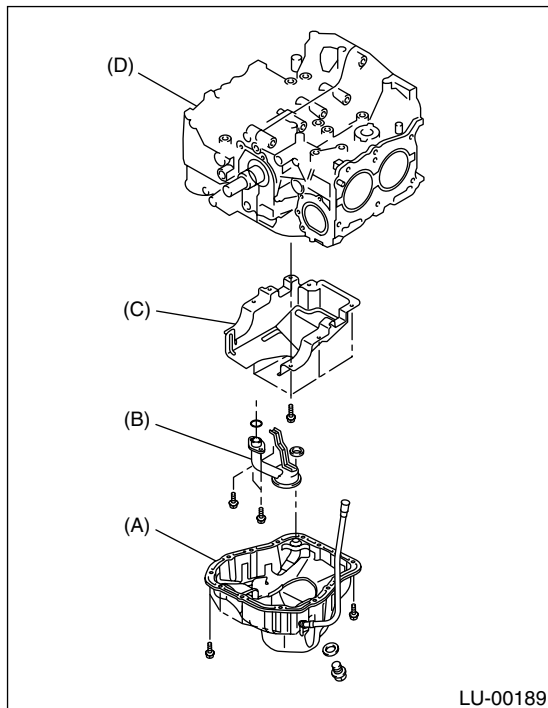

- (A) Oil pan
- (B) Oil strainer
- (C) Baffle plate
- (D) Cylinder block

## B: INSTALLATION

**CAUTION:**

Before installing the oil pan, clean sealant from oil pan and engine block.

1) Install the baffle plate.

**Tightening torque:**

**6.4 N·m (0.65 kgf-m, 4.7 ft-lb)**

2) Install the oil strainer onto baffle plate.

**NOTE:**

Replace the O-ring with a new one.

**Tightening torque:**

**10 N·m (1.0 kgf-m, 7.2 ft-lb)**

3) Apply fluid packing to the mating surfaces, and then install the oil pan.

**Fluid packing:**

**THREE BOND 1215 (Part No. 004403007) or equivalent**

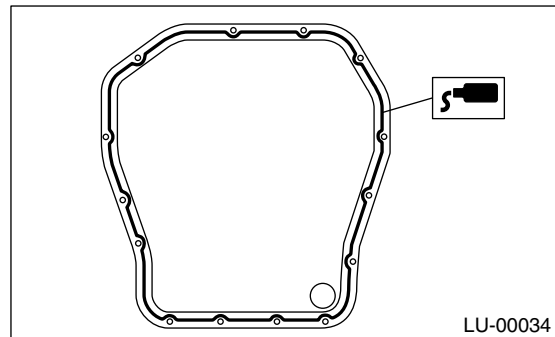

# OIL PAN AND STRAINER

## LUBRICATION

4) Tighten the bolts which install the oil pan onto engine block.

**Tightening torque:**

**5 N·m (0.5 kgf·m, 3.6 ft·lb)**

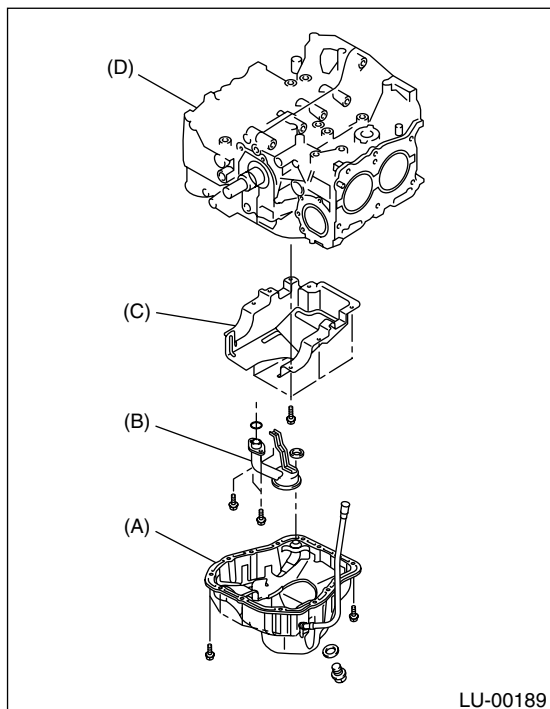

- (A) Oil pan
- (B) Oil strainer
- (C) Baffle plate
- (D) Cylinder block

5) Lower the engine onto front crossmember.

6) Tighten the nuts which install the front cushion rubber onto front crossmember.

**Tightening torque:**

**83 N·m (8.5 kgf·m, 61 ft·lb)**

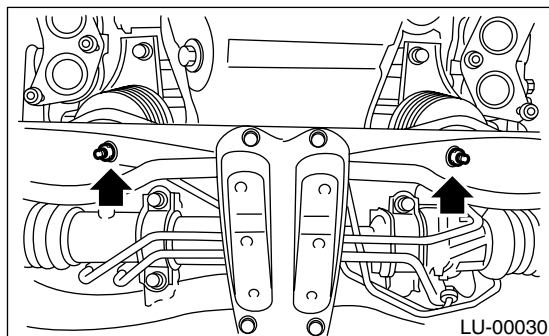

7) Install the under cover.

8) Lower the vehicle.

**CAUTION:**

**When lowering the vehicle, lower the lifting device and wire rope together.**

9) Remove the lifting device and steel cables.

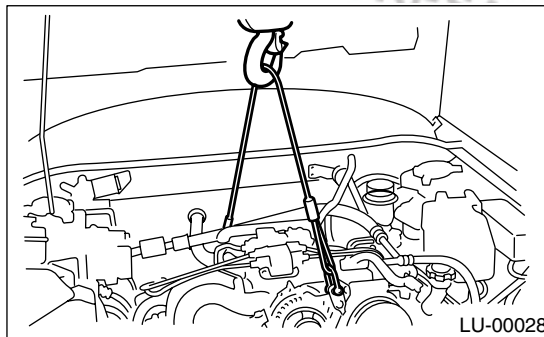

10) Install the pitching stopper.

**Tightening torque:**

**T1: 50 N·m (5.1 kgf·m, 36.9 ft·lb)**

**T2: 58 N·m (5.9 kgf·m, 42.8 ft·lb)**

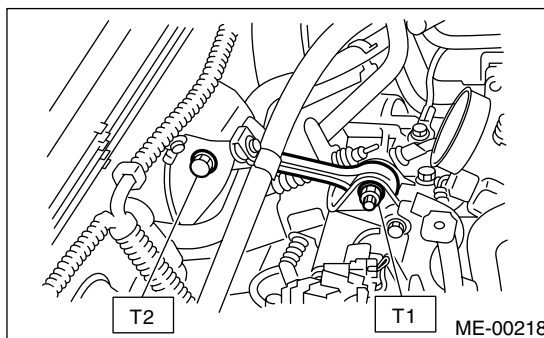

11) Install the radiator upper brackets.

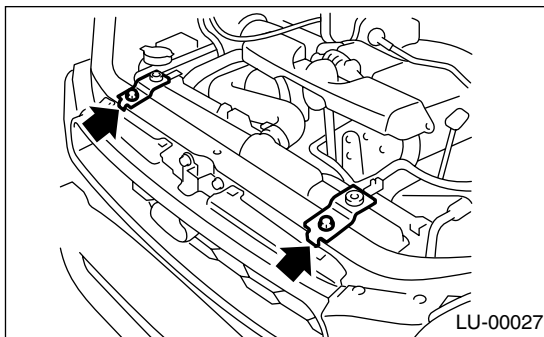

12) Install the intercooler. <Ref. to IN(H4DOTC)-10, INSTALLATION, Intercooler.>

13) Install the air intake boot and air cleaner upper cover.

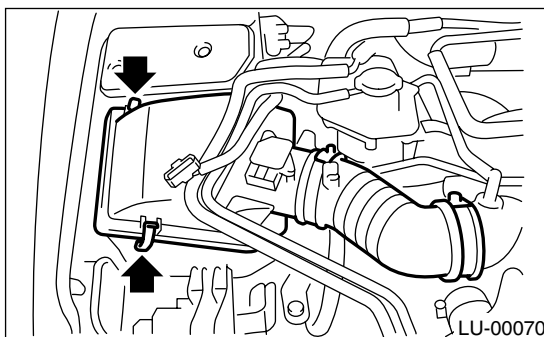



14) Connect the connector to mass air flow sensor.

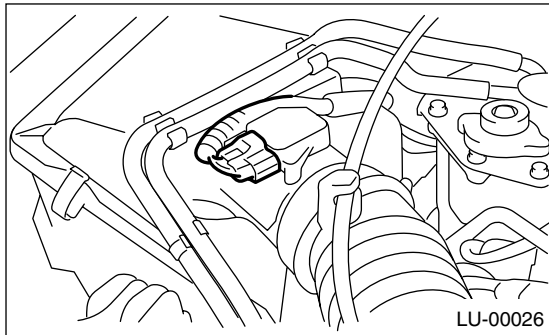

15) Install the front wheels.

16) Connect the battery ground cable to battery.

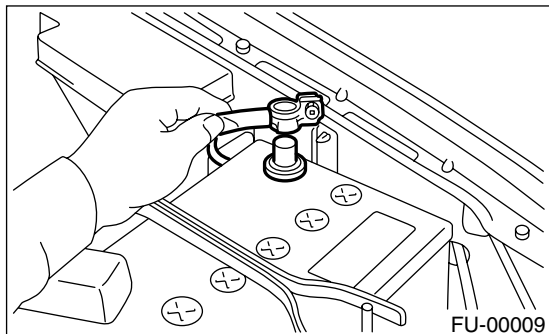

17) Fill engine oil. <Ref. to LU(STi)-8, INSPECTION, Engine Oil.>

## C: INSPECTION

By visual check, make sure the oil pan, oil strainer, oil strainer stay and baffle plate are not damaged.

## 6. Oil Pressure Switch

### A: REMOVAL

- 1) Remove the generator from bracket. <Ref. to SC(H4SO)-14, REMOVAL, Generator.>
- 2) Disconnect the terminal from oil pressure switch.

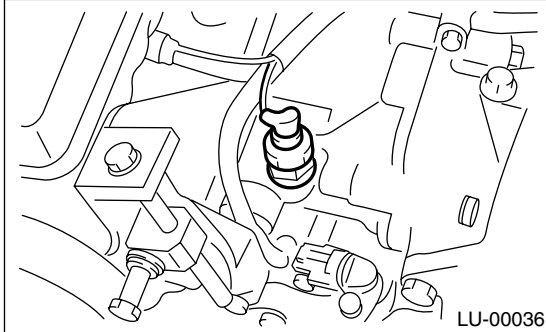

- 3) Remove the oil pressure switch.

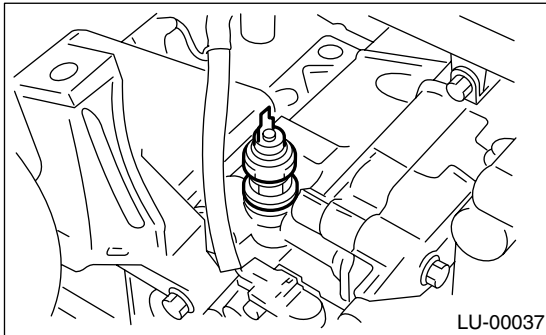

### B: INSTALLATION

- 1) Apply fluid packing to the oil pressure switch threads.

**Fluid packing:**  
**THREE BOND 1324 (Part No. 004403007) or equivalent**

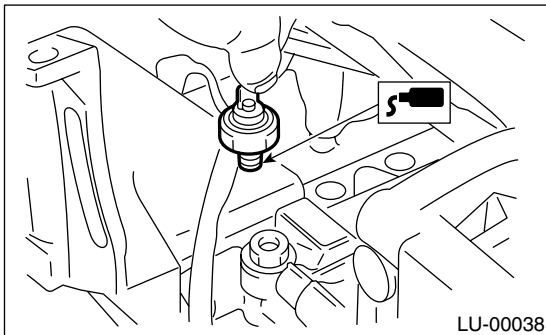

- 2) Install the oil pressure switch onto engine block.

**Tightening torque:**  
**25 N·m (2.5 kgf-m, 18.1 ft-lb)**

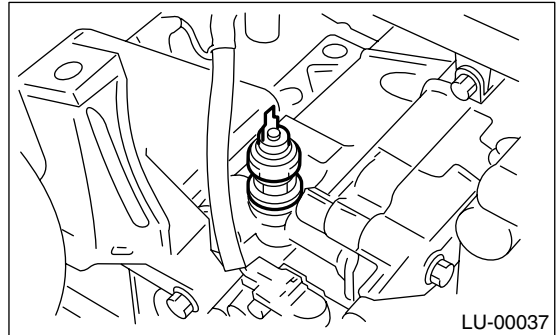

- 3) Connect the terminal of oil pressure switch.

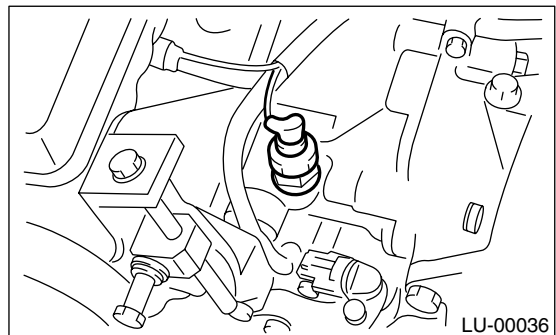

- 4) Install the generator on bracket. <Ref. to SC(H4SO)-14, INSTALLATION, Generator.>

### C: INSPECTION

Make sure oil does not leak or seep from where the oil pressure switch is installed.

## 7. Engine Oil Cooler

### A: REMOVAL

- 1) Lift-up the vehicle.
- 2) Remove the under cover.
- 3) Drain the engine oil.
- 4) Drain the engine coolant.
- 5) Remove the water by-pass pipe between oil cooler and water pump.

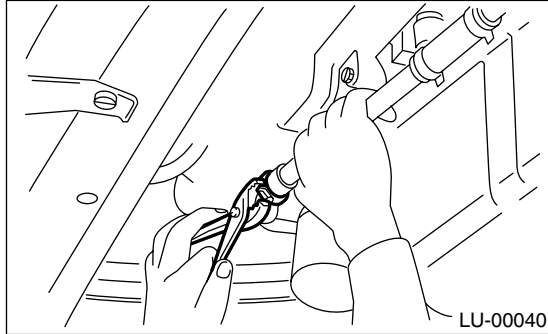

- 6) Remove the engine oil filter. <Ref. to LU(STi)-20, REMOVAL, Engine Oil Filter.>
- 7) Remove the connector, and then remove the oil cooler.

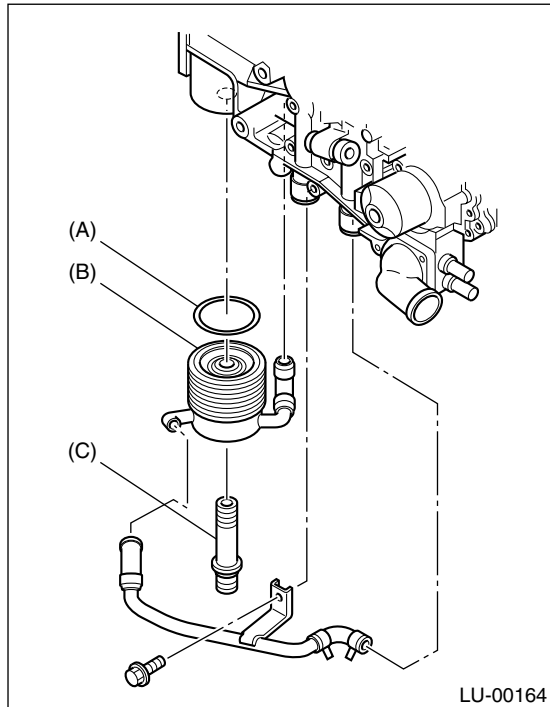

- (A) O-ring
- (B) Oil cooler
- (C) Oil cooler connector

### B: INSTALLATION

Install in the reverse order of removal.

#### *Tightening torque:*

**T: 54 N·m (5.5 kgf-m, 40 ft-lb)**

#### NOTE:

Always use a new O-ring.

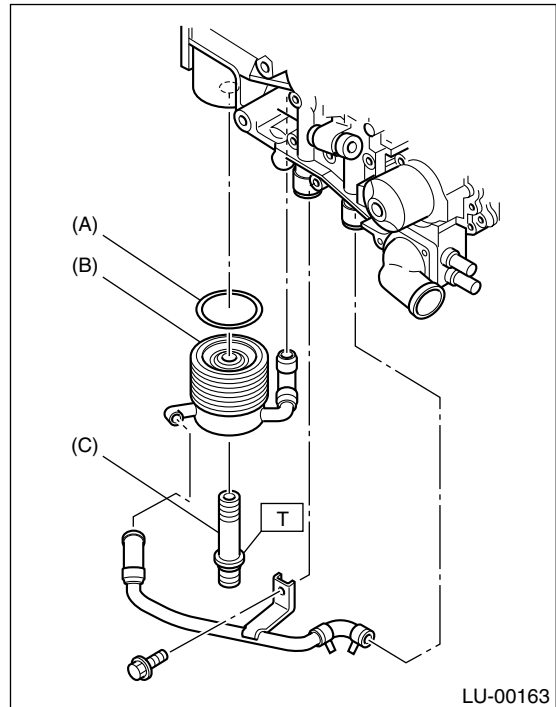

### C: INSPECTION

- 1) Check the coolant passages are not clogged using air blow method.
- 2) Check the mating surfaces of cylinder block, O-ring groove and oil filter for damage.

## 8. Engine Oil Filter

### A: REMOVAL

- 1) Remove the under cover.
- 2) Remove the oil filter with ST.

ST 18332AA000 OIL FILTER WRENCH (Outer diameter: 68 mm (2.68 in))

ST 18332AA010 OIL FILTER WRENCH (Outer diameter: 65 mm (2.56 in))

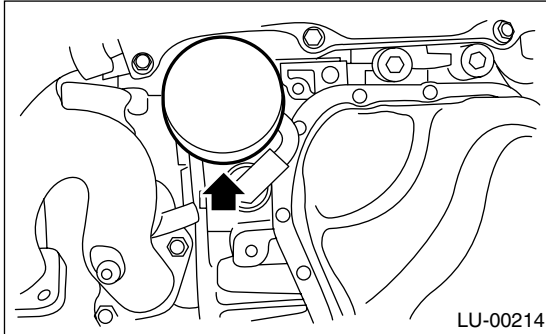

### B: INSTALLATION

- 1) Get a new oil filter and apply a thin coat of engine oil to seal rubber.
- 2) Install the oil filter by turning it by hand, being careful not to damage seal rubber.
- 3) Tighten more (approx. 2/3 to 3/4 turn) after the seal rubber contacts the oil cooler. Do not tighten excessively, or oil may leak.

### C: INSPECTION

- 1) After installing the oil filter, run the engine and make sure that no oil is leaking around seal rubber.

#### NOTE:

The filter element and filter case are permanently jointed; therefore, interior cleaning is not necessary.

- 2) Check the engine oil level. <Ref. to LU(STi)-8, INSPECTION, Engine Oil.>

# ENGINE LUBRICATION SYSTEM TROUBLE IN GENERAL

LUBRICATION

## 9. Engine Lubrication System Trouble in General

### A: INSPECTION

Before performing diagnostics, make sure that the engine oil level is correct and no oil leakage exists.

Trouble	Possible cause		Corrective action
1. Warning light remains on.	1) Oil pressure switch failure	Cracked diaphragm or oil leakage within switch	Replace.
		Broken spring or seized contacts	Replace.
	2) Low oil pressure	Clogged oil filter	Replace.
		Malfunction of oil by-pass valve of oil filter	Clean or replace.
		Malfunction of oil relief valve of oil pump	Clean or replace.
		Clogged oil passage	Clean.
		Excessive tip clearance and side clearance of oil pump rotor and gear	Replace.
		Clogged oil strainer or broken pipe	Clean or replace.
	3) No oil pressure	Insufficient engine oil	Replenish.
		Broken pipe of oil strainer	Replace.
Stuck oil pump rotor		Replace.	
2. Warning light does not go on.	1) Poor contact of switch contact points		Replace.
	2) Disconnection of wiring		Repair.
3. Warning light flickers momentarily.	1) Poor contact at terminals		Repair.
	2) Defective wiring harness		Repair.
	3) Low oil pressure		Check for the same possible causes as listed in 1. — 2).