

## 3. Engine Oil

### A: REPLACEMENT

1) Open the engine oil filler cap for quick draining of the engine oil.

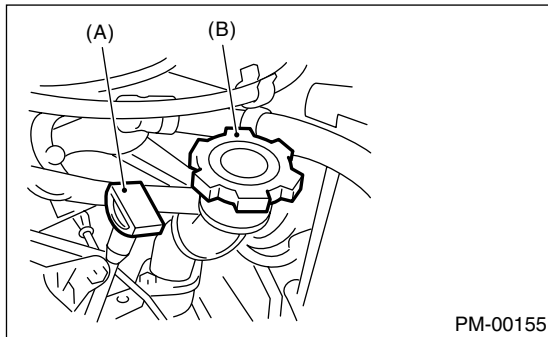

- (A) Oil level gauge
- (B) Oil filler cap

2) Drain the engine oil by loosening engine oil drain plug.

- TURBO MODEL

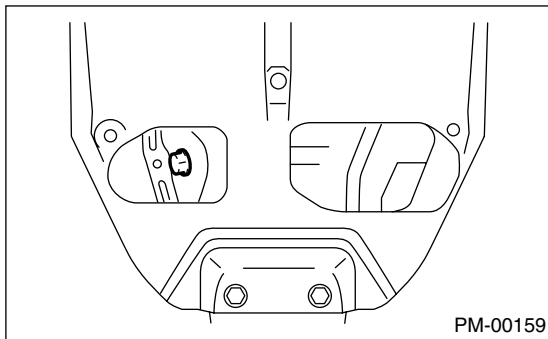

- STi MODEL

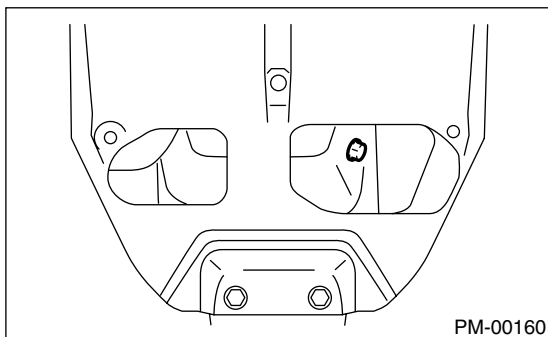

- NON-TURBO MODEL

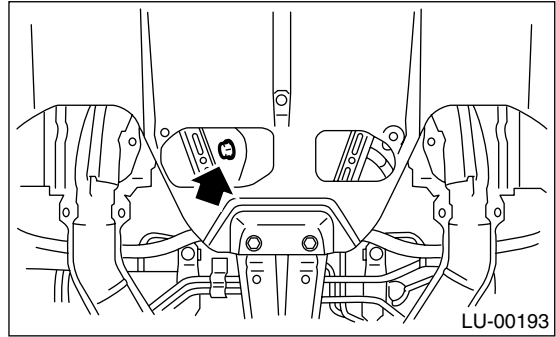

3) Replace the drain plug gasket.

4) Tighten the engine oil drain plug after draining engine oil.

**Tightening torque:**

**44 N·m (4.5 kgf·m, 33 ft·lb)**

- TURBO MODEL

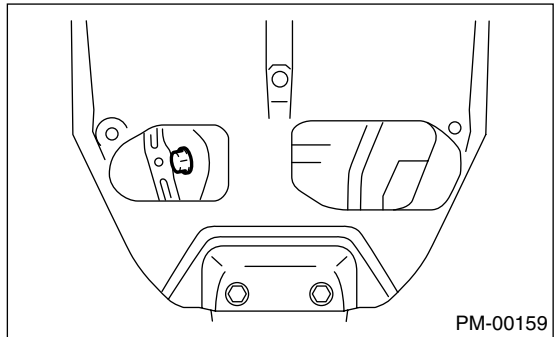

- STi MODEL

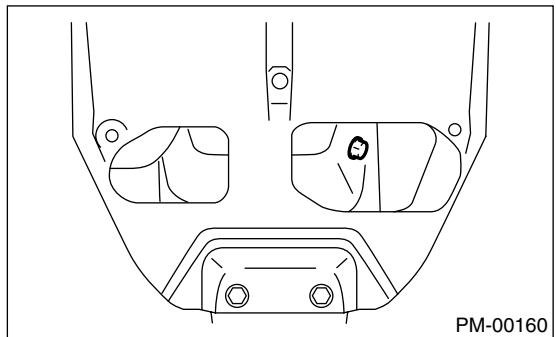

# ENGINE OIL

## PERIODIC MAINTENANCE SERVICES

### • NON-TURBO MODEL

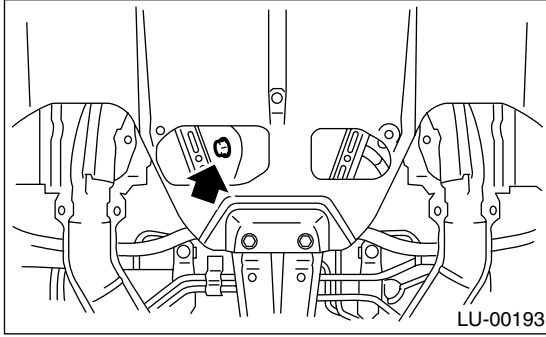

5) Fill engine oil through the filler pipe up to center between upper level and lower level. Make sure that the vehicle is placed level when checking oil level. Use engine oil of proper quality and viscosity, selected in accordance with the table in figure.

#### Recommended oil

##### API classification

**SL with the words “Energy Conserving or Energy conserving II” or New API mark displayed on the container (If it is impossible to get SL grade, you may use SJ grade.)**

##### ILSAC classification

**GF-3**

#### Engine oil capacity

##### Non-turbo model (Upper level):

**Approx. 4.0 ℓ (4.2 US qt, 3.5 Imp qt)**

##### Non-turbo model (Lower level):

**Approx. 3.0 ℓ (3.2 US qt, 2.6 Imp qt)**

##### Turbo model (Upper level):

**Approx. 4.5 ℓ (4.8 US qt, 4.0 Imp qt)**

##### Turbo model (Lower level):

**Approx. 3.5 ℓ (3.7 US qt, 3.1 Imp qt)**

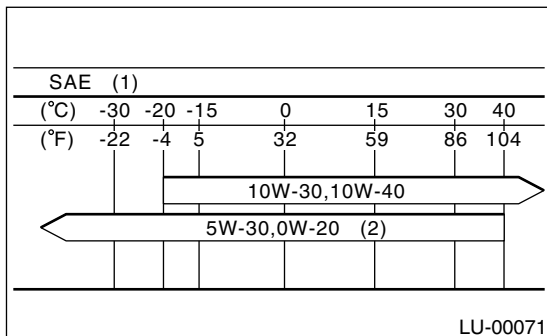

(1) Viscosity No. and applicable temperature

(2) Preferred

The proper viscosity helps vehicle get good cold and hot starting by reducing viscous friction and thus increasing cranking speed.

#### NOTE:

- When replenishing oil, it does not matter if the oil to be added is a different brand from that in the engine; however, use oil having the API classification and SAE viscosity No. designated by SUBARU.

- If vehicle is used in desert areas with very high temperatures or for other heavy duty applications, the following viscosity oils may be used:

API classification: SL or SJ.

ILSAC classification: GF-3.

SAE Viscosity No.: 30, 40, 10W-50, 20W-40, 20W-50

6) Close the engine oil filler cap.

7) Start the engine and warm it up for a time.

8) After the engine stops, recheck the oil level. <Ref. to PM-6, INSPECTION, Engine Oil.>

### B: INSPECTION

1) Park the vehicle on a level surface.

2) Remove the oil level gauge and wipe it clean.

3) Reinsert the level gauge all the way. Be sure that the level gauge is correctly inserted and in the proper orientation.

4) Remove it again and note the reading. If the engine oil level is below the “L” line, add oil to bring the level up to the “F” line.

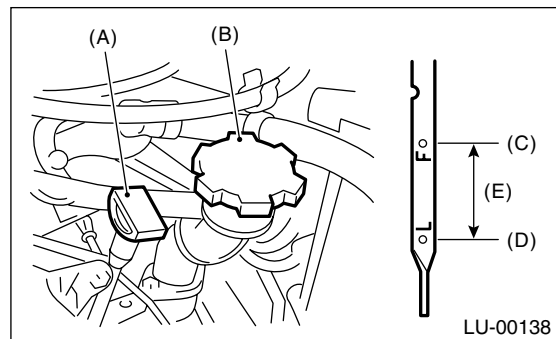

(A) Oil level gauge

(B) Oil filler cap

(C) Upper level

(D) Lower level

(E) Approx. 1 ℓ (1.1 Us qt, 0.9 Imp qt)

5) After turning off the engine, wait a few minutes for the oil to drain back into oil pan before checking the level.

6) Just after driving or while the engine is warm, engine oil level may show in the range between the “F” line and the notch mark. This is caused by thermal expansion of the engine oil.

7) To prevent overfilling the engine oil, do not add oil above the “F” line when the engine is cold.