

5. AT Shift Lock Solenoid and “P” Range Switch

A: REMOVAL

- 1) Disconnect the ground cable from battery.
- 2) Remove the console box. <Ref. to EI-43, REMOVAL, Console Box.>
- 3) Disconnect the connector.
- 4) Remove the grip.
- 5) Remove the indicator bulb from indicator cover.

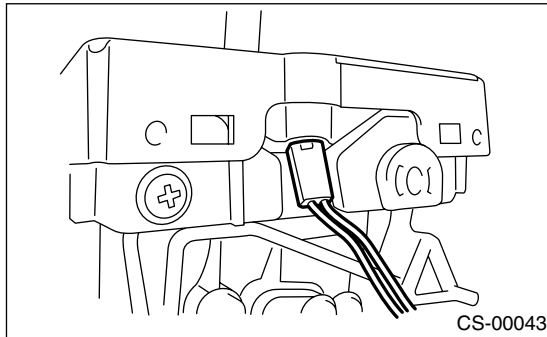

- 6) Remove the indicator cover.

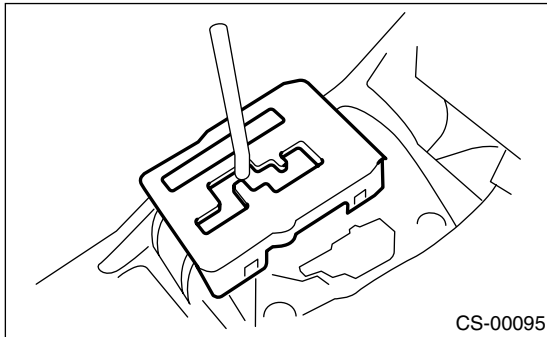

- 7) Remove the blind.
- 8) Remove the cushion.
- 9) Remove the clip, and then remove the “P” range switch.

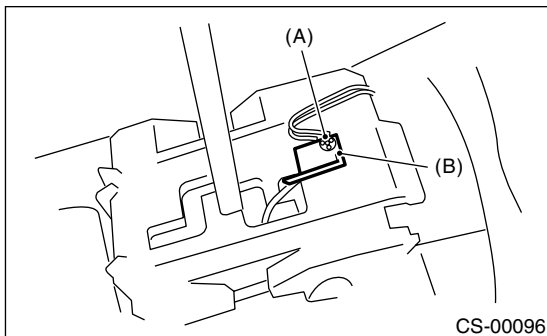

- (A) Clip
- (B) “P” range switch

- 10) Remove the clamp, and then remove the shift lock solenoid.

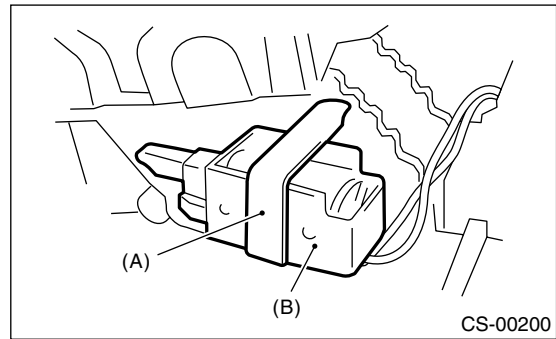

- (A) Clamp
- (B) Shift lock solenoid

B: INSTALLATION

Install in the reverse order of removal.

AT SHIFT LOCK SOLENOID AND “P” RANGE SWITCH

CONTROL SYSTEMS

C: INSPECTION

Step	Check	Yes	No
1 CHECK SHIFT LOCK SOLENOID. Measure the resistance of shift lock solenoid connector terminals. <i>Terminals</i> <i>No. 4 — No. 5:</i>	Is the resistance between 20 and 40 Ω ?	Go to step 2.	Replace the shift lock solenoid and “P” range switch assembly.
2 CHECK SHIFT LOCK SOLENOID. Connect the battery with shift lock solenoid connector terminal, operate solenoid. <i>Terminals</i> <i>No. 4 (+) — No. 5 (-):</i>	Is the shift lock solenoid operating properly?	Go to step 3.	Replace the shift lock solenoid and “P” range switch assembly.
3 CHECK “P” RANGE SWITCH. 1) Move the select lever to “P” range. 2) Measure the resistance between “P” range switch connector terminals.	Is the resistance less than 1 Ω ?	Go to step 4.	Replace the “P” range switch.
4 CHECK “P” RANGE SWITCH. 1) Move the select lever to other than “P” range. 2) Measure the resistance between “P” range switch connector terminals.	Is the resistance more than 1 $M\Omega$?	Normal	Replace the “P” range switch.