

15. Diagnostic Procedure without Diagnostic Trouble Code (DTC)

A: CHECK FWD SWITCH

DIAGNOSIS:

- The LED does not come on even if FWD switch is ON.
- The FWD switch circuit is open or short.

WIRING DIAGRAM:

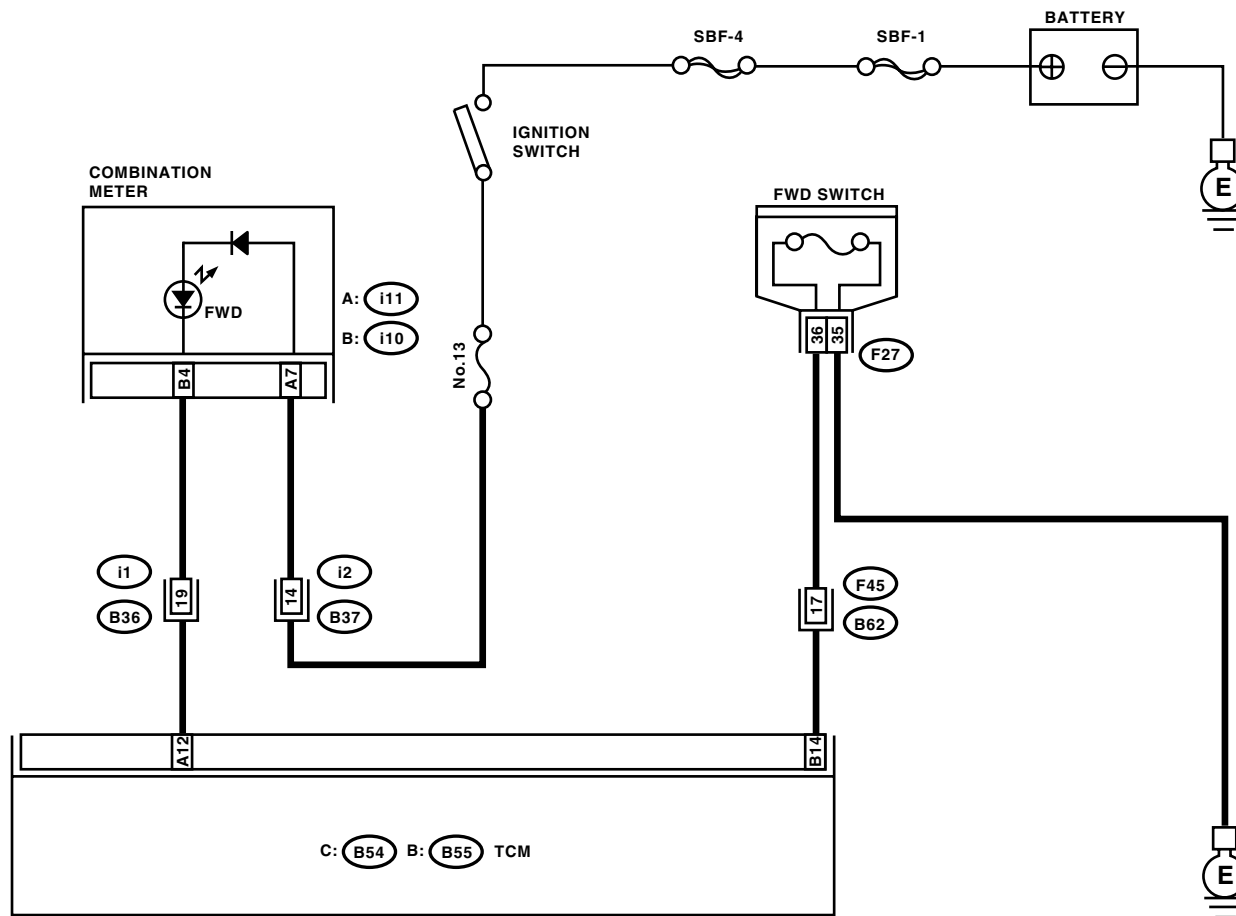

A: B54

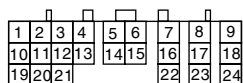

B: B55

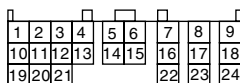

i2

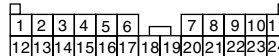

B: i10

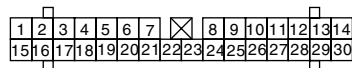

A: i11

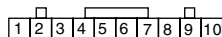

F45 i1

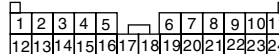

F27

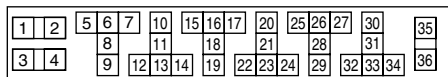

DIAGNOSTIC PROCEDURE WITHOUT DIAGNOSTIC TROUBLE CODE (DTC)

AUTOMATIC TRANSMISSION (DIAGNOSTICS)

Step	Check	Yes	No	
1	CHECK VEHICLE.	Is the target non-turbo model?	Go to step 2.	Go to step CHECK BRAKE SWITCH. <Ref. to 4AT-99, CHECK BRAKE SWITCH, Diagnostic Procedure without Diagnostic Trouble Code (DTC).>
2	CHECK FWD SWITCH.	When the fuse is inserted to FWD switch, does LED light up?	Go to step CHECK BRAKE SWITCH.<Ref. to 4AT-99, CHECK BRAKE SWITCH, Diagnostic Procedure without Diagnostic Trouble Code (DTC).>	Go to step 3.
3	CHECK FWD INDICATOR LIGHT. 1)Turn the ignition switch to OFF. 2)Remove the combination meter.	Is the FWD indicator light bulb OK?	Go to step 4.	Check the FWD indicator light bulb. <Ref. to IDI-10, Combination Meter Assembly.>
4	CHECK HARNESS CONNECTOR BETWEEN TCM AND FWD SWITCH. 1)Turn the ignition switch to OFF. 2)Disconnect the connector from TCM. 3)Measure the resistance of harness between TCM and FWD switch connector. Connector & terminal (B55) No. 14 — (F27) No. 36:	Is the resistance less than 1 Ω ?	Go to step 5.	Repair the open circuit in harness between TCM and FWD switch connector.
5	CHECK HARNESS CONNECTOR BETWEEN FWD SWITCH AND CHASSIS GROUND. Measure the resistance of harness between FWD switch and chassis ground. Connector & terminal (F27) No. 35 — Chassis ground:	Is the resistance less than 1 Ω ?	Go to step 6.	Repair the open circuit in harness between FWD switch connector and chassis ground.
6	CHECK HARNESS CONNECTOR BETWEEN TCM AND FWD SWITCH. Measure the resistance of harness connector between TCM and body to make sure that circuit does not short. Connector & terminal (B55) No. 14 — Chassis ground:	Is the resistance more than 1 M Ω ?	Go to step 7.	Repair the short circuit in harness between TCM and FWD switch connector.
7	CHECK INPUT SIGNAL FOR TCM. 1)Turn the ignition switch to OFF. 2)Connect the connector to TCM. 3)Turn the ignition switch to ON. 4)Measure the signal voltage for TCM while installing the fuse to FWD switch connector. Connector & terminal (B55) No. 14 (+) — Chassis ground (-):	Is the voltage less than 1 V?	Go to step 8.	Go to step 12.
8	CHECK INPUT SIGNAL FOR TCM. Measure the signal voltage for TCM while removing the fuse from FWD switch connector. Connector & terminal (B55) No. 14 (+) — Chassis ground (-):	Is the voltage 6 — 9.1 V?	Go to step 9.	Replace the TCM. <Ref. to 4AT-67, Transmission Control Module (TCM).>

DIAGNOSTIC PROCEDURE WITHOUT DIAGNOSTIC TROUBLE CODE (DTC)

AUTOMATIC TRANSMISSION (DIAGNOSTICS)

Step	Check	Yes	No
9 CHECK HARNESS CONNECTOR BETWEEN TCM AND COMBINATION METER. 1) Turn the ignition switch to OFF. 2) Disconnect the connector from TCM and combination meter. 3) Measure the resistance of harness between TCM and diagnosis connector. Connector & terminal (B54) No. 12 — (i10) No. 4:	Is the resistance less than 1 Ω ?	Go to step 10 .	Repair the open circuit in harness between TCM and combination meter and poor contact in coupling connector.
10 CHECK HARNESS CONNECTOR BETWEEN TCM AND COMBINATION METER. Measure the resistance of harness connector between TCM and chassis ground to make sure that circuit does not short. Connector & terminal (B54) No. 12 — Chassis ground:	Is the resistance more than 1 M Ω ?	Go to step 11 .	Repair the short circuit in harness between TCM and combination meter connector.
11 CHECK OUTPUT SIGNAL EMITTED FROM TCM. 1) Turn the ignition switch to OFF. 2) Connect the connector to TCM and combination meter. 3) Turn the ignition switch to ON. 4) Measure the signal voltage for TCM while installing the fuse to FWD switch connector. Connector & terminal (B54) No. 12 (+) — Chassis ground (-):	Is the voltage less than 1 V?	Go to step 12 .	Go to step 13 .
12 CHECK OUTPUT SIGNAL EMITTED FROM TCM. Measure the signal voltage for TCM while removing the fuse from FWD switch connector. Connector & terminal (B54) No. 12 (+) — Chassis ground (-):	Is the voltage 6 — 9.1 V?	Go to step 13 .	Replace the TCM. <Ref. to 4AT-67, Transmission Control Module (TCM).>
13 CHECK POOR CONTACT.	Is there poor contact in FWD switch circuit?	Repair the poor contact.	Replace the TCM. <Ref. to 4AT-67, Transmission Control Module (TCM).>

DIAGNOSTIC PROCEDURE WITHOUT DIAGNOSTIC TROUBLE CODE (DTC)
AUTOMATIC TRANSMISSION (DIAGNOSTICS)

B: CHECK BRAKE SWITCH

Step	Check	Yes	No
1 CHECK BRAKE SWITCH.	When the brake pedal is depressed, does LED light up?	Go to step CHECK CRUISE CONTROL SWITCH. <Ref. to 4AT-99, CHECK CRUISE CONTROL SWITCH, Diagnostic Procedure without Diagnostic Trouble Code (DTC).>	Check the brake switch circuit.

C: CHECK CRUISE CONTROL SWITCH

Step	Check	Yes	No
1 CHECK CRUISE CONTROL SWITCH.	When the cruise control is set, does LED light up?	Go to step CHECK INHIBITOR SWITCH. <Ref. to 4AT-100, CHECK INHIBITOR SWITCH, Diagnostic Procedure without Diagnostic Trouble Code (DTC).>	Check the cruise control. <Ref. to CC-29, Diagnostic Procedure with DTC.>

DIAGNOSTIC PROCEDURE WITHOUT DIAGNOSTIC TROUBLE CODE (DTC)

AUTOMATIC TRANSMISSION (DIAGNOSTICS)

D: CHECK INHIBITOR SWITCH

DIAGNOSIS:

The input signal circuit of inhibitor switch is open or shorted.

TROUBLE SYMPTOM:

- Shift characteristics are erroneous.
- Engine brake is not effected when selector lever is in "3" range.
- Engine brake is not effected when selector lever is in "2" range.
- Engine brake is not effected when selector lever is in "1" range.

WIRING DIAGRAM:

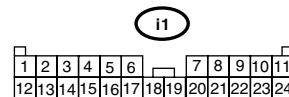
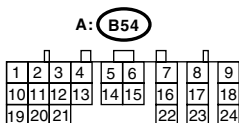
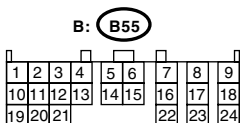
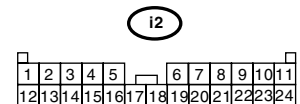
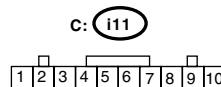
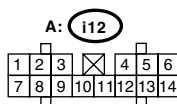
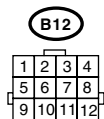
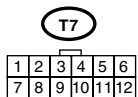
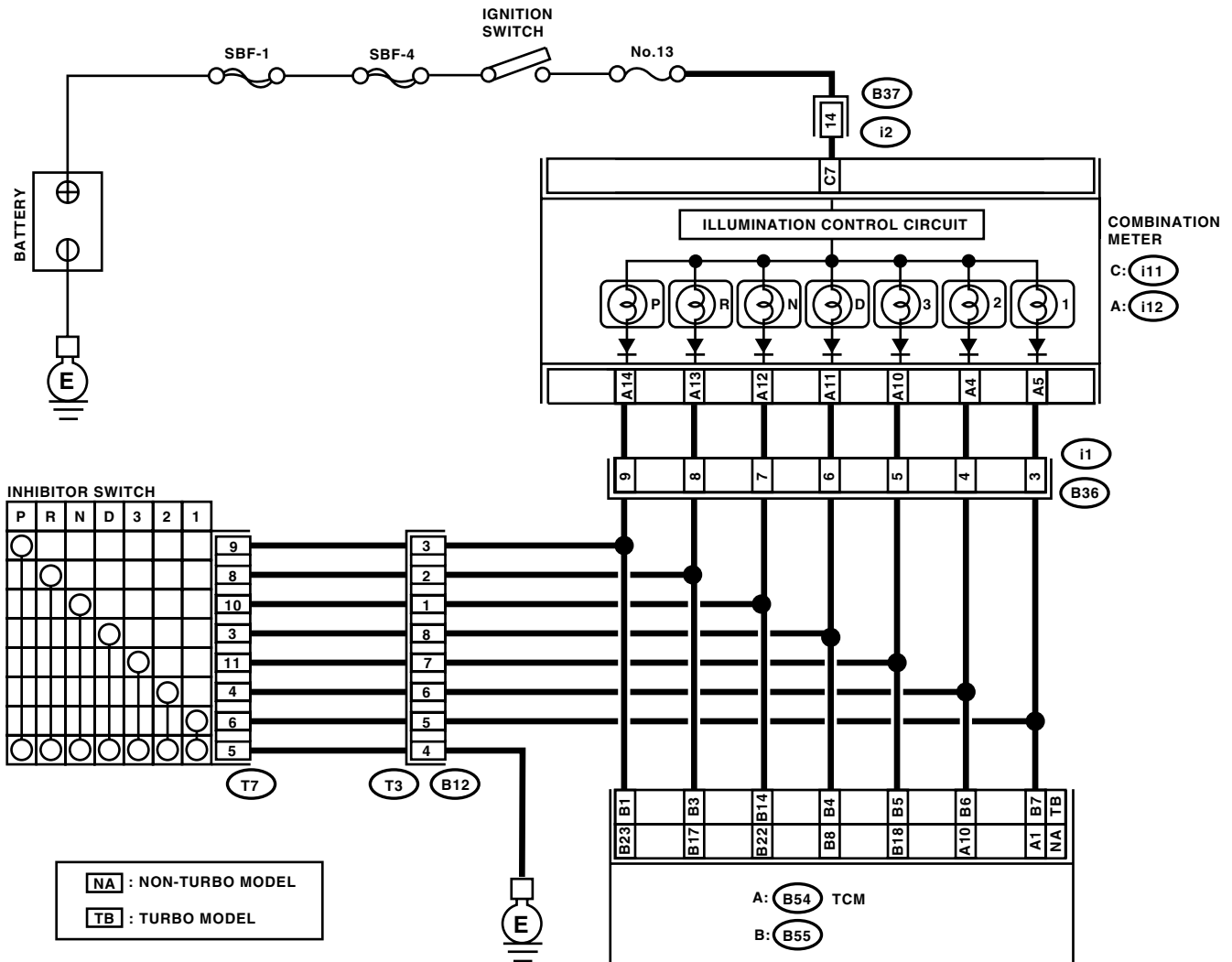

DIAGNOSTIC PROCEDURE WITHOUT DIAGNOSTIC TROUBLE CODE (DTC)

AUTOMATIC TRANSMISSION (DIAGNOSTICS)

Step	Check	Yes	No	
1	CHECK "P" RANGE SWITCH.	When the "P" range is selected, does LED light up?	Go to step 2.	Go to step 22.
2	CHECK INDICATOR LIGHT.	Does the combination meter "P" range indicator illuminate?	Go to step 3.	Go to step 26.
3	CHECK "P" RANGE SWITCH.	When the "R" range is selected, does "P" range LED light up?	Go to step 28.	Go to step 4.
4	CHECK "R" RANGE SWITCH.	When the "R" range is selected, does LED light up?	Go to step 5.	Go to step 29.
5	CHECK INDICATOR LIGHT.	Does the combination meter "R" range indicator illuminate?	Go to step 6.	Go to step 32.
6	CHECK "R" RANGE SWITCH.	When the "N" range is selected, does "R" range LED light up?	Go to step 34.	Go to step 7.
7	CHECK "N" RANGE SWITCH.	When the "N" range is selected, does LED light up?	Go to step 8.	Go to step 35.
8	CHECK INDICATOR LIGHT.	Does the combination meter "N" range indicator illuminate?	Go to step 9.	Go to step 38.
9	CHECK "N" RANGE SWITCH.	When the "D" range is selected, does "N" range LED light up?	Go to step 40.	Go to step 10.
10	CHECK "D" RANGE SWITCH.	When the "D" range is selected, does LED light up?	Go to step 11.	Go to step 41.
11	CHECK INDICATOR LIGHT.	Does the combination meter "D" range indicator illuminate?	Go to step 12.	Go to step 44.
12	CHECK "D" RANGE SWITCH.	When the "3" range is selected, does "D" range LED light up?	Go to step 46.	Go to step 13.
13	CHECK "3" RANGE SWITCH.	When the "3" range is selected, does LED light up?	Go to step 14.	Go to step 47.
14	CHECK INDICATOR LIGHT.	Does the combination meter "3" range indicator illuminate?	Go to step 15.	Go to step 50.
15	CHECK "3" RANGE SWITCH.	When the "2" range is selected, does "3" range LED light up?	Go to step 52.	Go to step 16.
16	CHECK "2" RANGE SWITCH.	When the "2" range is selected, does LED light up?	Go to step 17.	Go to step 53.
17	CHECK INDICATOR LIGHT.	Does the combination meter "2" range indicator illuminate?	Go to step 18.	Go to step 56.
18	CHECK "2" RANGE SWITCH.	When the "1" range is selected, does "2" range LED light up?	Go to step 58.	Go to step 19.
19	CHECK "1" RANGE SWITCH.	When the "1" range is selected, does LED light up?	Go to step 20.	Go to step 59.
20	CHECK INDICATOR LIGHT.	Does the combination meter "1" range indicator illuminate?	Go to step 21.	Go to step 62.
21	CHECK "1" RANGE SWITCH.	When the "2" range is selected, does "1" range LED light UP?	Go to step 64.	Go to step Symptom Related Diagnostic. <Ref. to 4AT-111, Symptom Related Diagnostic.>

DIAGNOSTIC PROCEDURE WITHOUT DIAGNOSTIC TROUBLE CODE (DTC)

AUTOMATIC TRANSMISSION (DIAGNOSTICS)

Step	Check	Yes	No
22 CHECK HARNESS CONNECTOR BETWEEN INHIBITOR SWITCH AND CHASSIS GROUND. 1) Turn the ignition switch to OFF. 2) Disconnect the connector from inhibitor switch. 3) Measure the resistance of harness between inhibitor switch and chassis ground. <i>Connector & terminal</i> <i>(T7) No. 5 — Chassis ground:</i>	Is the resistance less than 1 Ω ?	Go to step 23.	Repair the open circuit in harness between inhibitor switch connector and chassis ground, and poor contact in coupling connector.
23 CHECK HARNESS CONNECTOR BETWEEN TCM AND INHIBITOR SWITCH. 1) Turn the ignition switch to OFF. 2) Disconnect the connectors from TCM and inhibitor switch. 3) Measure the resistance of harness between TCM and inhibitor switch connector. <i>Connector & terminal</i> <i>NON-TURBO MODEL</i> <i>(B55) No. 23 — (T7) No. 9:</i> <i>TURBO MODEL</i> <i>(B55) No. 1 — (T7) No. 9:</i>	Is the resistance less than 1 Ω ?	Go to step 24.	Repair the open circuit in harness between TCM and inhibitor switch connector, and poor contact in coupling connector.
24 CHECK INPUT SIGNAL FOR TCM. 1) Turn the ignition switch to OFF. 2) Connect the connector to TCM and inhibitor switch. 3) Turn the ignition switch to ON. 4) Move the select lever to "P" range. 5) Measure the voltage between TCM and chassis ground. <i>Connector & terminal</i> <i>NON-TURBO MODEL</i> <i>(B55) No. 23 (+) — Chassis ground (-):</i> <i>TURBO MODEL</i> <i>(B55) No. 1 (+) — Chassis ground (-):</i>	Is the voltage less than 1 V?	Go to step 25.	Go to step 65.
25 CHECK INPUT SIGNAL FOR TCM. 1) Position the select lever to any other than "P" range. 2) Measure the voltage between TCM and chassis ground. <i>Connector & terminal</i> <i>NON-TURBO MODEL</i> <i>(B55) No. 23 (+) — Chassis ground (-):</i> <i>TURBO MODEL</i> <i>(B55) No. 1 (+) — Chassis ground (-):</i>	Is the voltage more than 8 V?	Go to step 65.	Replace the TCM. <Ref. to 4AT-67, Transmission Control Module (TCM).>
26 CHECK "P" RANGE INDICATOR LIGHT BULB. 1) Turn the ignition switch to OFF. 2) Remove the combination meter. 3) Remove the "P" range indicator light bulb from combination meter.	Is the "P" range indicator light bulb OK?	Go to step 27.	Replace the "P" range indicator light bulb. <Ref. to IDI-10, Combination Meter Assembly.>

DIAGNOSTIC PROCEDURE WITHOUT DIAGNOSTIC TROUBLE CODE (DTC)

AUTOMATIC TRANSMISSION (DIAGNOSTICS)

Step	Check	Yes	No
27 CHECK HARNESS CONNECTOR BETWEEN TCM AND COMBINATION METER. 1) Disconnect the connectors from TCM and combination meter. 2) Measure the resistance of harness between TCM and combination meter. <i>Connector & terminal</i> NON-TURBO MODEL (B55) No. 23 — (i12) No. 14: TURBO MODEL (B55) No. 1 — (i12) No. 14:	Is the resistance more than 1 Ω ?	Go to step 65.	Repair the open circuit in harness between TCM connector and combination meter, and poor contact in coupling connector.
28 CHECK HARNESS CONNECTOR BETWEEN TCM AND INHIBITOR SWITCH. 1) Turn the ignition switch to OFF. 2) Disconnect the connectors from TCM, inhibitor switch and combination meter. 3) Measure the resistance of harness between TCM and chassis ground. <i>Connector & terminal</i> NON-TURBO MODEL (B55) No. 23 — Chassis ground: TURBO MODEL (B55) No. 1 — Chassis ground:	Is the resistance less than 1 M Ω ?	Go to step 29.	Repair the ground short circuit in "P" range circuit.
29 CHECK HARNESS CONNECTOR BETWEEN TCM AND INHIBITOR SWITCH. 1) Turn the ignition switch to OFF. 2) Disconnect the connectors from TCM and inhibitor switch. 3) Measure the resistance of harness between TCM and inhibitor switch connector. <i>Connector & terminal</i> NON-TURBO MODEL (B55) No. 17 — (T7) No. 8: TURBO MODEL (B55) No. 3 — (T7) No. 8:	Is the resistance less than 1 Ω ?	Go to step 30.	Repair the open circuit in harness between TCM and inhibitor switch connector, and poor contact in coupling connector.
30 CHECK INPUT SIGNAL FOR TCM. 1) Turn the ignition switch to OFF. 2) Connect the connector to TCM and inhibitor switch. 3) Turn the ignition switch to ON. 4) Move the select lever to "R" range. 5) Measure the voltage between TCM and chassis ground. <i>Connector & terminal</i> NON-TURBO MODEL (B55) No. 17 (+) — Chassis ground (-): TURBO MODEL (B55) No. 3 (+) — Chassis ground (-):	Is the voltage less than 1 V?	Go to step 31.	Go to step 65.
31 CHECK INPUT SIGNAL FOR TCM. 1) Position the select lever to any other than "R" range. 2) Measure the voltage between TCM and chassis ground. <i>Connector & terminal</i> NON-TURBO MODEL (B55) No. 17 (+) — Chassis ground (-): TURBO MODEL (B55) No. 3 (+) — Chassis ground (-):	Is the voltage more than 8 V?	Go to step 65.	Replace the TCM. <Ref. to 4AT-67, Transmission Control Module (TCM).>

DIAGNOSTIC PROCEDURE WITHOUT DIAGNOSTIC TROUBLE CODE (DTC)

AUTOMATIC TRANSMISSION (DIAGNOSTICS)

Step	Check	Yes	No
32 CHECK "R" RANGE INDICATOR LIGHT BULB. 1) Turn the ignition switch to OFF. 2) Remove the combination meter. 3) Remove the "R" range indicator light bulb from combination meter.	Is "R" range indicator light bulb OK?	Go to step 33 .	Replace the "R" range indicator light bulb. <Ref. to IDI-10, Combination Meter Assembly.>
33 CHECK HARNESS CONNECTOR BETWEEN TCM AND COMBINATION METER. 1) Disconnect the connectors from TCM and combination meter. 2) Measure the resistance of harness between TCM and combination meter. <i>Connector & terminal</i> <i>NON-TURBO MODEL</i> <i>(B55) No. 17 — (i12) No. 13:</i> <i>TURBO MODEL</i> <i>(B55) No. 3 — (i12) No. 13:</i>	Is the resistance less than 1 Ω ?	Go to step 65 .	Repair the open circuit in harness between TCM connector and combination meter, and poor contact in TCM connector.
34 CHECK HARNESS CONNECTOR BETWEEN TCM AND INHIBITOR SWITCH. 1) Turn the ignition switch to OFF. 2) Disconnect the connectors from TCM, inhibitor switch and combination meter. 3) Measure the resistance of harness between TCM and chassis ground. <i>Connector & terminal</i> <i>NON-TURBO MODEL</i> <i>(B55) No. 17 — Chassis ground:</i> <i>TURBO MODEL</i> <i>(B55) No. 3 — Chassis ground:</i>	Is the resistance more than 1 $M\Omega$?	Go to step 35 .	Repair the ground short circuit in "R" range circuit.
35 CHECK HARNESS CONNECTOR BETWEEN TCM AND INHIBITOR SWITCH. 1) Turn the ignition switch to OFF. 2) Disconnect the connectors from TCM and inhibitor switch. 3) Measure the resistance of harness between TCM and inhibitor switch connector. <i>Connector & terminal</i> <i>NON-TURBO MODEL</i> <i>(B55) No. 22 — (T7) No. 10:</i> <i>TURBO MODEL</i> <i>(B55) No. 14 — (T7) No. 10:</i>	Is the resistance less than 1 Ω ?	Go to step 36 .	Repair the open circuit in harness between TCM and inhibitor switch connector, and poor contact in coupling connector.
36 CHECK INPUT SIGNAL FOR TCM. 1) Turn the ignition switch to OFF. 2) Connect the connector to TCM and inhibitor switch. 3) Turn the ignition switch to ON. 4) Move the select lever to "N" range. 5) Measure the voltage between TCM and chassis ground. <i>Connector & terminal</i> <i>NON-TURBO MODEL</i> <i>(B55) No. 22 (+) — Chassis ground (-):</i> <i>TURBO MODEL</i> <i>(B55) No. 14 (+) — Chassis ground (-):</i>	Is the voltage less than 1 V?	Go to step 37 .	Go to step 65 .

DIAGNOSTIC PROCEDURE WITHOUT DIAGNOSTIC TROUBLE CODE (DTC)

AUTOMATIC TRANSMISSION (DIAGNOSTICS)

Step	Check	Yes	No
37 CHECK INPUT SIGNAL FOR TCM. 1)Position the select lever to any other than "N" range. 2)Measure the voltage between TCM and chassis ground. <i>Connector & terminal</i> NON-TURBO MODEL (B55) No. 22 (+) — Chassis ground (-): TURBO MODEL (B55) No. 14 (+) — Chassis ground (-):	Is the voltage more than 8 V?	Go to step 65.	Replace the TCM. <Ref. to 4AT-67, Transmission Control Module (TCM).>
38 CHECK "N" RANGE INDICATOR LIGHT BULB. 1)Turn the ignition switch to OFF. 2)Remove the combination meter. 3)Remove the "N" range indicator light bulb from combination meter.	Is the "N" range indicator light bulb OK?	Go to step 39.	Replace the "N" range indicator light bulb. <Ref. to IDI-10, Combination Meter Assembly.>
39 CHECK HARNESS CONNECTOR BETWEEN TCM AND COMBINATION METER. 1)Disconnect the connectors from TCM and combination meter. 2)Measure the resistance of harness between TCM and combination meter. <i>Connector & terminal</i> NON-TURBO MODEL (B55) No. 22 — (i12) No. 12: TURBO MODEL (B55) No. 14 — (i12) No. 12:	Is the resistance less than 1 Ω ?	Go to step 65.	Repair the open circuit in harness between TCM connector and combination meter, and poor contact in TCM connector.
40 CHECK HARNESS CONNECTOR BETWEEN TCM AND INHIBITOR SWITCH. 1)Turn the ignition switch to OFF. 2)Disconnect the connectors from TCM, inhibitor switch and combination meter. 3)Measure the resistance of harness between TCM and chassis ground. <i>Connector & terminal</i> NON-TURBO MODEL (B55) No. 22 — Chassis ground: TURBO MODEL (B55) No. 14 — Chassis ground:	Is the resistance more than 1 M Ω ?	Go to step 41.	Repair the ground short circuit in "N" range circuit.
41 CHECK HARNESS CONNECTOR BETWEEN TCM AND INHIBITOR SWITCH. 1)Turn the ignition switch to OFF. 2)Disconnect the connectors from TCM and inhibitor switch. 3)Measure the resistance of harness between TCM and inhibitor switch connector. <i>Connector & terminal</i> NON-TURBO MODEL (B55) No. 8 — (T7) No. 3: TURBO MODEL (B55) No. 4 — (T7) No. 3:	Is the resistance less than 1 Ω ?	Go to step 42.	Repair the open circuit in harness between TCM and inhibitor switch connector, and poor contact in coupling connector.

DIAGNOSTIC PROCEDURE WITHOUT DIAGNOSTIC TROUBLE CODE (DTC)

AUTOMATIC TRANSMISSION (DIAGNOSTICS)

Step	Check	Yes	No
42 CHECK INPUT SIGNAL FOR TCM. 1) Turn the ignition switch to OFF. 2) Connect the connector to TCM and inhibitor switch. 3) Turn the ignition switch to ON. 4) Move the select lever to "D" range. 5) Measure the voltage between TCM and chassis ground. <i>Connector & terminal</i> NON-TURBO MODEL (B55) No. 8 (+) — Chassis ground (-): TURBO MODEL (B55) No. 4 (+) — Chassis ground (-):	Is the voltage less than 1 V?	Go to step 43.	Go to step 65.
43 CHECK INPUT SIGNAL FOR TCM. 1) Position select lever to any other than "D" range. 2) Measure the voltage between TCM and chassis ground. <i>Connector & terminal</i> NON-TURBO MODEL (B55) No. 8 (+) — Chassis ground (-): TURBO MODEL (B55) No. 4 (+) — Chassis ground (-):	Is the voltage more than 8 V?	Go to step 65.	Replace the TCM. <Ref. to 4AT-67, Transmission Control Module (TCM).>
44 CHECK "D" RANGE INDICATOR LIGHT BULB. 1) Turn the ignition switch to OFF. 2) Remove the combination meter. 3) Remove the "D" range indicator light bulb from combination meter.	Is the "D" range indicator light bulb OK?	Go to step 45.	Replace the "D" range indicator light bulb. <Ref. to IDI-10, Combination Meter Assembly.>
45 CHECK HARNESS CONNECTOR BETWEEN TCM AND COMBINATION METER. 1) Disconnect the connectors from TCM and combination meter. 2) Measure the resistance of harness between TCM and combination meter. <i>Connector & terminal</i> NON-TURBO MODEL (B55) No. 8 — (i12) No. 11: TURBO MODEL (B55) No. 4 — (i12) No. 11:	Is the resistance less than 1 Ω ?	Go to step 65.	Repair the open circuit in harness between TCM connector and combination meter, and TCM connector.
46 CHECK HARNESS CONNECTOR BETWEEN TCM AND INHIBITOR SWITCH. 1) Turn the ignition switch to OFF. 2) Disconnect the connectors from TCM, inhibitor switch and combination meter. 3) Measure the resistance of harness between TCM and chassis ground. <i>Connector & terminal</i> NON-TURBO MODEL (B55) No. 8 — Chassis ground: TURBO MODEL (B55) No. 4 — Chassis ground:	Is the resistance more than 1 M Ω ?	Go to step 47.	Repair the ground short circuit in "D" range circuit.

DIAGNOSTIC PROCEDURE WITHOUT DIAGNOSTIC TROUBLE CODE (DTC)

AUTOMATIC TRANSMISSION (DIAGNOSTICS)

Step	Check	Yes	No
47 CHECK HARNESS CONNECTOR BETWEEN TCM AND INHIBITOR SWITCH. 1) Turn the ignition switch to OFF. 2) Disconnect the connector from TCM and inhibitor switch. 3) Measure the resistance of harness between TCM and inhibitor switch connector. <i>Connector & terminal</i> NON-TURBO MODEL (B55) No. 18 — (T7) No. 11: TURBO MODEL (B55) No. 5 — (T7) No. 11:	Is the resistance less than 1 Ω ?	Go to step 48.	Repair the open circuit in harness between TCM and inhibitor switch connector, and poor contact in coupling connector.
48 CHECK INPUT SIGNAL FOR TCM. 1) Turn the ignition switch to OFF. 2) Connect the connector to TCM and inhibitor switch. 3) Turn the ignition switch to ON. 4) Move the select lever to "3" range. 5) Measure the voltage between TCM and chassis ground. <i>Connector & terminal</i> NON-TURBO MODEL (B55) No. 18 (+) — Chassis ground (-): TURBO MODEL (B55) No. 5 (+) — Chassis ground (-):	Is the voltage less than 1 V?	Go to step 49.	Go to step 65.
49 CHECK INPUT SIGNAL FOR TCM. 1) Position the select lever to any other than "3" range. 2) Measure the voltage between TCM and chassis ground. <i>Connector & terminal</i> NON-TURBO MODEL (B55) No. 18 (+) — Chassis ground (-): TURBO MODEL (B55) No. 5 (+) — Chassis ground (-):	Is the voltage more than 8 V?	Go to step 65.	Replace the TCM. <Ref. to 4AT-67, Transmission Control Module (TCM).>
50 CHECK "3" RANGE INDICATOR LIGHT BULB. 1) Turn the ignition switch to OFF. 2) Remove the combination meter. 3) Remove the "3" range indicator light bulb from combination meter.	Is the "3" range indicator light bulb OK?	Go to step 51.	Replace the "3" range indicator light bulb. <Ref. to IDI-10, Combination Meter Assembly.>
51 CHECK HARNESS CONNECTOR BETWEEN TCM AND COMBINATION METER. 1) Disconnect the connectors from TCM and combination meter. 2) Measure the resistance of harness between TCM and combination meter. <i>Connector & terminal</i> NON-TURBO MODEL (B55) No. 18 — (i12) No. 10: TURBO MODEL (B55) No. 5 — (i12) No. 10:	Is the resistance more than 1 Ω ?	Go to step 65.	Repair the open circuit in harness between TCM connector and combination meter, and poor contact in TCM connector.

DIAGNOSTIC PROCEDURE WITHOUT DIAGNOSTIC TROUBLE CODE (DTC)

AUTOMATIC TRANSMISSION (DIAGNOSTICS)

Step	Check	Yes	No
52 CHECK HARNESS CONNECTOR BETWEEN TCM AND INHIBITOR SWITCH. 1) Turn the ignition switch to OFF. 2) Disconnect the connectors from TCM, inhibitor switch and combination meter. 3) Measure the resistance of harness between TCM and chassis ground. <i>Connector & terminal</i> <i>NON-TURBO MODEL</i> <i>(B55) No. 18 — Chassis ground:</i> <i>TURBO MODEL</i> <i>(B55) No. 5 — Chassis ground:</i>	Is the resistance more than 1 M Ω ?	Go to step 53.	Repair the ground short circuit in "3" range circuit.
53 CHECK HARNESS CONNECTOR BETWEEN TCM AND INHIBITOR SWITCH. 1) Turn the ignition switch to OFF. 2) Disconnect the connector from TCM and inhibitor switch. 3) Measure the resistance of harness between TCM and inhibitor switch connector. <i>Connector & terminal</i> <i>NON-TURBO MODEL</i> <i>(B54) No. 10 — (T7) No. 4:</i> <i>TURBO MODEL</i> <i>(B55) No. 6 — (T7) No. 4:</i>	Is the resistance less than 1 Ω ?	Go to step 54.	Repair the open circuit in harness between TCM and inhibitor switch connector, and poor contact in coupling connector.
54 CHECK INPUT SIGNAL FOR TCM. 1) Turn the ignition switch to OFF. 2) Connect the connector to TCM and inhibitor switch. 3) Turn the ignition switch to ON. 4) Move the select lever to "2" range. 5) Measure the voltage between TCM and chassis ground. <i>Connector & terminal</i> <i>NON-TURBO MODEL</i> <i>(B54) No. 10 (+) — Chassis ground (-):</i> <i>TURBO MODEL</i> <i>(B55) No. 6 (+) — Chassis ground (-):</i>	Is the voltage less than 1 V?	Go to step 55.	Go to step 65.
55 CHECK INPUT SIGNAL FOR TCM. 1) Position the select lever to any other than "2" range. 2) Measure the voltage between TCM and chassis ground. <i>Connector & terminal</i> <i>NON-TURBO MODEL</i> <i>(B54) No. 10 (+) — Chassis ground (-):</i> <i>TURBO MODEL</i> <i>(B55) No. 6 (+) — Chassis ground (-):</i>	Is the voltage more than 8 V?	Go to step 65.	Replace the TCM. <Ref. to 4AT-67, Transmission Control Module (TCM).>
56 CHECK "2" RANGE INDICATOR LIGHT BULB. 1) Turn the ignition switch to OFF. 2) Remove the combination meter. 3) Remove the "2" range indicator light bulb from combination meter.	Is the "2" range indicator light bulb OK?	Go to step 57.	Replace the "2" range indicator light bulb. <Ref. to IDI-10, Combination Meter Assembly.>

DIAGNOSTIC PROCEDURE WITHOUT DIAGNOSTIC TROUBLE CODE (DTC)

AUTOMATIC TRANSMISSION (DIAGNOSTICS)

Step	Check	Yes	No
57 CHECK HARNESS CONNECTOR BETWEEN TCM AND COMBINATION METER. 1)Disconnect the connectors from TCM and combination meter. 2)Measure the resistance of harness between TCM and combination meter. <i>Connector & terminal</i> NON-TURBO MODEL <i>(B54) No. 10 — (i12) No. 4:</i> TURBO MODEL <i>(B55) No. 6 — (i12) No. 4:</i>	Is the resistance less than 1 Ω ?	Go to step 65 .	Repair the open circuit in harness between TCM and combination meter, and poor contact in TCM connector.
58 CHECK HARNESS CONNECTOR BETWEEN TCM AND INHIBITOR SWITCH. 1)Turn the ignition switch to OFF. 2)Disconnect the connectors from TCM, inhibitor switch and combination meter. 3)Measure the resistance of harness between TCM and chassis ground. <i>Connector & terminal</i> NON-TURBO MODEL <i>(B54) No. 10 — Chassis ground:</i> TURBO MODEL <i>(B55) No. 6 — Chassis ground:</i>	Is the resistance more than 1 M Ω ?	Go to step 59 .	Repair the ground short circuit in "2" range circuit.
59 CHECK HARNESS CONNECTOR BETWEEN TCM AND INHIBITOR SWITCH. 1)Turn the ignition switch to OFF. 2)Disconnect the connectors from TCM and inhibitor switch. 3)Measure the resistance of harness between TCM and inhibitor switch connector. <i>Connector & terminal</i> NON-TURBO MODEL <i>(B54) No. 1 — (T7) No. 6:</i> TURBO MODEL <i>(B55) No. 7 — (T7) No. 6:</i>	Is the resistance less than 1 Ω ?	Go to step 60 .	Repair the open circuit in harness between TCM and inhibitor switch connector, and poor contact in coupling connector.
60 CHECK INPUT SIGNAL FOR TCM. 1)Turn the ignition switch to OFF. 2)Connect the connector to TCM and inhibitor switch. 3)Turn the ignition switch to ON. 4)Move the select lever to "1" range. 5)Measure the voltage between TCM and chassis ground. <i>Connector & terminal</i> NON-TURBO MODEL <i>(B54) No. 1 (+) — Chassis ground (-):</i> TURBO MODEL <i>(B55) No. 7 (+) — Chassis ground (-):</i>	Is the voltage less than 1 V?	Go to step 61 .	Go to step 65 .
61 CHECK INPUT SIGNAL FOR TCM. 1)Position the select lever to any other than "1" range. 2)Measure the voltage between TCM and chassis ground. <i>Connector & terminal</i> NON-TURBO MODEL <i>(B54) No. 1 (+) — Chassis ground (-):</i> TURBO MODEL <i>(B55) No. 7 (+) — Chassis ground (-):</i>	Is the voltage more than 8 V?	Go to step 65 .	Replace the TCM. <Ref. to 4AT-67, Transmission Control Module (TCM).>

DIAGNOSTIC PROCEDURE WITHOUT DIAGNOSTIC TROUBLE CODE (DTC)

AUTOMATIC TRANSMISSION (DIAGNOSTICS)

Step	Check	Yes	No
62 CHECK "1" RANGE INDICATOR LIGHT BULB. 1) Turn the ignition switch to OFF. 2) Remove the combination meter. 3) Remove the "1" range indicator light bulb from combination meter.	Is the "1" range indicator light bulb OK?	Go to step 63 .	Replace the "1" range indicator light bulb. <Ref. to IDI-10, Combination Meter Assembly.>
63 CHECK HARNESS CONNECTOR BETWEEN TCM AND COMBINATION METER. 1) Disconnect the connectors from TCM and combination meter. 2) Measure the resistance of harness between TCM and combination meter. Connector & terminal NON-TURBO MODEL (B54) No. 1 — (i12) No. 5: TURBO MODEL (B55) No. 7 — (i12) No. 5:	Is the resistance less than 1Ω?	Go to step 65 .	Repair the open circuit in harness between TCM and combination meter, poor contact in TCM connector.
64 CHECK HARNESS CONNECTOR BETWEEN TCM AND INHIBITOR SWITCH. 1) Turn the ignition switch to OFF. 2) Disconnect the connectors from TCM, inhibitor switch and combination meter. 3) Measure the resistance of harness between TCM and chassis ground. Connector & terminal NON-TURBO MODEL (B54) No. 1 — Chassis ground: TURBO MODEL (B55) No. 7 — Chassis ground:	Is the resistance more than 1 MΩ?	Go to step 65 .	Repair the ground short circuit in "1" range circuit.
65 CHECK POOR CONTACT.	Is there poor contact in inhibitor switch circuit?	Repair the poor contact.	Adjust the inhibitor switch and select cable. <Ref. to 4AT-45, ADJUSTMENT, Inhibitor Switch.> and <Ref. to CS-26, Select Cable.>