

GENERAL DESCRIPTION

MANUAL TRANSMISSION AND DIFFERENTIAL

1. General Description

A: SPECIFICATIONS

1. MANUAL TRANSMISSION AND DIFFERENTIAL

Model		2.5 L		2.0 L Turbo
		Sedan	Wagon	
Type		5-forward speeds with synchromesh and 1-reverse		
Transmission gear ratio		1st	3.454	3.454
		2nd	2.062	1.947
		3rd	1.448	1.366
		4th	1.088	0.972
		5th	0.780	0.738
		Reverse	3.333	
Front reduction gear	Final	Type of gear	Hypoid	
		Gear ratio	4.111	3.900
Rear reduction gear	Transfer	Type of gear	Helical	
		Gear ratio	1.000	1.100
	Final	Type of gear	Hypoid	
		Gear ratio	4.111	3.900
Front differential	Type and number of gear		Straight bevel gear (Bevel pinion: 2, Bevel gear: 2)	
Center differential	Type and number of gear		Straight bevel gear (Bevel pinion: 2, Bevel gear: 2 and viscous coupling)	
Transmission gear oil		GL-5		
Transmission oil capacity		3.5 ℓ (3.7 US qt, 3.1 Imp qt)		

2. TRANSMISSION GEAR OIL

Recommended oil

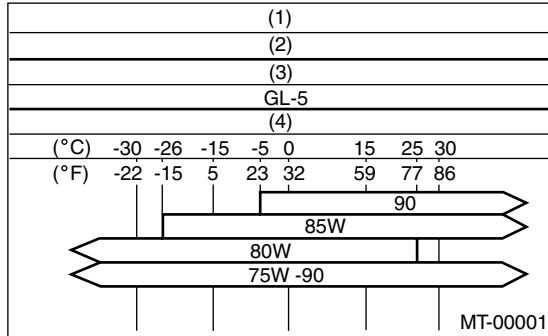

- (1) Item
- (2) Transmission gear oil
- (3) API classification
- (4) SAE viscosity No. and applicable temperature

GENERAL DESCRIPTION

MANUAL TRANSMISSION AND DIFFERENTIAL

3. TRANSMISSION CASE ASSEMBLY

Drive pinion shim adjustment

Hypoid gear backlash

0.13 — 0.18 mm (0.0051 — 0.0071 in)

Drive pinion shim			
Part No.	Thickness mm (in)	Part No.	Thickness mm (in)
32295AA031	0.150 (0.0059)	32295AA071	0.250 (0.0098)
32295AA041	0.175 (0.0069)	32295AA081	0.275 (0.0108)
32295AA051	0.200 (0.0079)	32295AA091	0.300 (0.0118)
32295AA061	0.225 (0.0089)	32295AA101	0.500 (0.0197)

Selection of main shaft rear plate

Main shaft rear plate		
Dimension "A" mm (in)	Part No.	Mark
4.00 — 4.13 (0.1575 — 0.1626)	32294AA041	1
3.87 — 3.99 (0.1524 — 0.1571)	32294AA051	2

4. DRIVE PINION ASSEMBLY

Preload adjustment of thrust bearing

Starting torque

0.3 — 0.8 N·m (0.03 — 0.08 kgf·m, 0.2 — 0.6 ft·lb)

Adjusting washer No. 1	
Part No.	Thickness mm (in)
803025051	3.925 (0.1545)
803025052	3.950 (0.1555)
803025053	3.975 (0.1565)
803025054	4.000 (0.1575)
803025055	4.025 (0.1585)
803025056	4.050 (0.1594)
803025057	4.075 (0.1604)

Adjusting washer No. 2	
Part No.	Thickness mm (in)
803025059	3.850 (0.1516)
803025054	4.000 (0.1575)
803025058	4.150 (0.1634)

5. MAIN SHAFT

Snap ring (Outer-25) to synchronizer hub clearance

0.060 — 0.100 mm (0.0024 — 0.0039 in)

Snap ring (Outer-25)			
Part No.	Thickness mm (in)	Part No.	Thickness mm (in)
805025051	2.42 (0.0953)	805025055	2.62 (0.1031)
805025052	2.47 (0.0972)	805025056	2.67 (0.1051)
805025053	2.52 (0.0992)	805025057	2.72 (0.1071)
805025054	2.57 (0.1012)	805025058	2.37 (0.0933)

6. REVERSE IDLER GEAR

Adjustment of reverse idler gear position

Reverse idler gear to transmission case (LH) wall clearance

6.0 — 7.5 mm (0.236 — 0.295 in)

Reverse shifter lever		
Part No.	Mark	Remarks
32820AA070	7	Further from case wall
32820AA080	8	Standard
32820AA090	9	Closer to the case wall

After installing a suitable reverse shifter lever, adjust the reverse idler gear to transmission case wall clearance to within 0 to 0.5 mm (0 to 0.020 in) using washers.

Washer (20.5 × 26 × t)			
Part No.	Thickness mm (in)	Part No.	Thickness mm (in)
803020151	0.4 (0.016)	803020154	1.9 (0.075)
803020152	1.1 (0.043)	803020155	2.3 (0.091)
803020153	1.5 (0.059)	—	—

GENERAL DESCRIPTION

MANUAL TRANSMISSION AND DIFFERENTIAL

7. SHIFTER FORK AND ROD

Select the suitable shifter forks so that both coupling sleeve and reverse driven gear are positioned in the center of their synchromesh mechanisms.

Rod end clearance

A: 1st-2nd — 3rd-4th

0.4 — 1.4 mm (0.016 — 0.055 in)

B: 3rd-4th — 5th

0.5 — 1.3 mm (0.020 — 0.051 in)

1st-2nd shifter fork		
Part No.	Mark	Remarks
32804AA060	1	Approach to 1st gear by 0.2 mm (0.008 in)
32804AA070	No mark	Standard
32804AA080	3	Approach to 2nd gear by 0.2 mm (0.008 in)

3rd-4th shifter fork		
Part No.	Mark	Remarks
32810AA061	1	Approach to 4th gear by 0.2 mm (0.008 in)
32810AA071	No mark	Standard
32810AA101	3	Approach to 3rd gear by 0.2 mm (0.008 in)

5th shifter fork (Non-turbo model)		
Part No.	Mark	Remarks
32812AA201	4	Approach to 5th gear by 0.2 mm (0.008 in)
32812AA211	5	Standard
32812AA221	6	Become distant from 5th gear by 0.2 mm (0.008 in)

5th shifter fork (Turbo model)		
Part No.	Mark	Remarks
32812AA231	7	Approach to 5th gear by 0.2 mm (0.008 in)
32812AA241	No mark	Standard
32812AA251	9	Become distant from 5th gear by 0.2 mm (0.008 in)

8. TRANSFER CASE OR REAR CASE

Neutral position adjustment

Adjustment shim	
Part No.	Thickness mm (in)
32190AA000	0.15 (0.0059)
32190AA010	0.30 (0.0118)

Reverse accent shaft		
Part No.	Mark	Remarks
32188AA090	3	Neutral position is closer to 1st.
32188AA100	0	Standard
32188AA110	1	Neutral position is closer to reverse gear.

Reverse check plate adjustment

Reverse check plate			
Part No.	Mark	Angle θ	Remarks
32189AA000	0	28°	Arm stops closer to 5th gear.
32189AA010	1	31°	Arm stops closer to 5th gear.
33189AA020	2	34°	Arm stops in the center.
32189AA030	3	37°	Arm stops closer to reverse gear.
32189AA040	4	40°	Arm stops closer to reverse gear.

GENERAL DESCRIPTION

MANUAL TRANSMISSION AND DIFFERENTIAL

9. EXTENSION ASSEMBLY

Thrust washer (50 × 61 × t) to taper roller bearing table outer race side clearance

0.2 — 0.3 mm (0.0008 — 0.012 in)

NOTE:

Be sure to keep the clearance within specifications.

Thrust washer (50 × 61 × t)	
Part No.	Thickness mm (in)
803050060	0.50 (0.0197)
803050061	0.55 (0.0217)
803050062	0.60 (0.0236)
803050063	0.65 (0.0256)
803050064	0.70 (0.0276)
803050065	0.75 (0.0295)
803050066	0.80 (0.0315)
803050067	0.85 (0.0335)
803050068	0.90 (0.0354)
803050069	0.95 (0.0374)
803050070	1.00 (0.0394)
803050071	1.05 (0.0413)
803050072	1.10 (0.0433)
803050073	1.15 (0.0453)
803050074	1.20 (0.0472)
803050075	1.25 (0.0492)
803050076	1.30 (0.0512)
803050077	1.35 (0.0531)
803050078	1.40 (0.0551)
803050079	1.45 (0.0571)

Thrust washer to center differential side clearance
0.15 — 0.35 mm (0.0059 — 0.0138 in)

Thrust washer	
Part No.	Thickness mm (in)
803036050	0.9 (0.035)
803036054	1.0 (0.039)
803036051	1.1 (0.043)
803036055	1.2 (0.047)
803036052	1.3 (0.051)
803036056	1.4 (0.055)
803036053	1.5 (0.059)
803036057	1.6 (0.063)
803036058	1.7 (0.067)

10. FRONT DIFFERENTIAL

Bevel gear to pinion backlash

0.13 — 0.18 mm (0.0051 — 0.0071 in)

Washer (38.1 × 50 × t)			
Part No.	Thickness mm (in)	Part No.	Thickness mm (in)
803038021	0.925 — 0.950 (0.0364 — 0.0374)	803038023	1.025 — 1.050 (0.0404 — 0.0413)
803038022	0.975 — 1.000 (0.0384 — 0.0394)	—	—

Pinion shaft to axle drive shaft clearance

0 — 0.2 mm (0 — 0.008 in)

Snap ring (Outer-28)			
Part No.	Thickness mm (in)	Part No.	Thickness mm (in)
805028011	1.05 (0.0413)	805028012	1.20 (0.0472)

11. TRANSFER DRIVE GEAR

Snap ring (Outer-30) to ball bearing clearance

0.01 — 0.15 mm (0.0004 — 0.0059 in)

Snap ring (Outer-30)	
Part No.	Thickness mm (in)
805030041	1.53 (0.0602)
805030042	1.65 (0.0650)
805030043	1.77 (0.0697)

GENERAL DESCRIPTION

MANUAL TRANSMISSION AND DIFFERENTIAL

B: COMPONENT

1. TRANSMISSION CASE

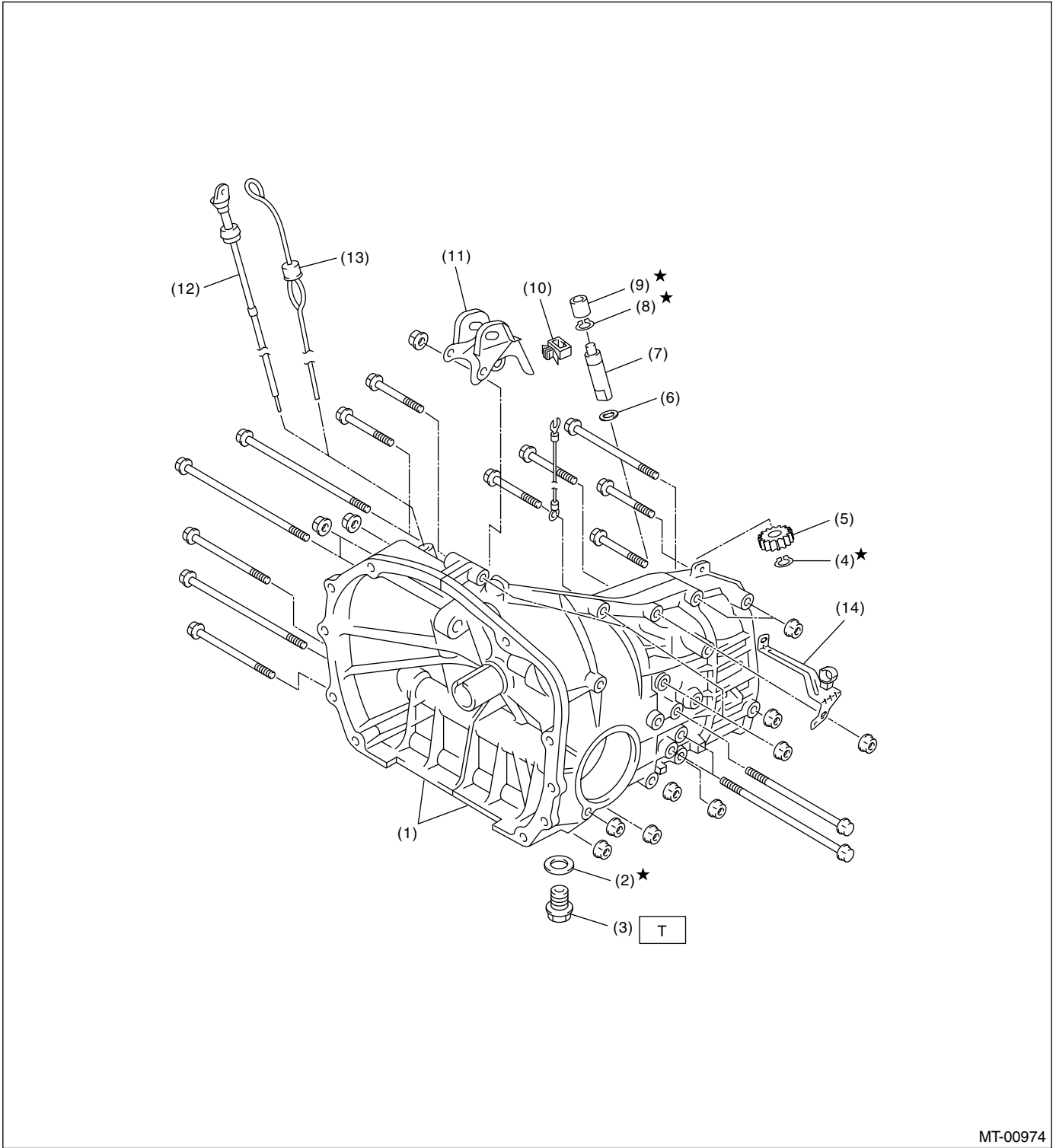

MT-00974

GENERAL DESCRIPTION

MANUAL TRANSMISSION AND DIFFERENTIAL

- | | | |
|-----------------------------|--|--|
| (1) Transmission case ASSY | (7) Speedometer shaft | (13) Oil level gauge (Turbo model) |
| (2) Gasket | (8) Snap ring (Outer) | (14) Harness bracket (Non-turbo model) |
| (3) Drain plug | (9) Oil seal | |
| (4) Snap ring (Outer) | (10) Clamp | |
| (5) Speedometer driven gear | (11) Pitching stopper bracket | |
| (6) Washer | (12) Oil level gauge (Non-turbo model) | |

Tightening torque: N·m (kgf·m, ft·lb)

T: 69 (7.0, 50.6)

• Transmission case tightening torque

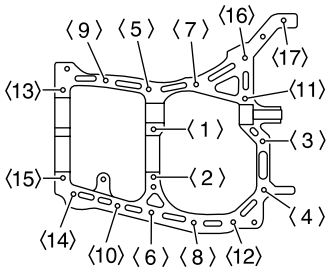
 <p>MT-00003</p>	Bolt No.	Bolt size	Tightening torque: N·m (kgf·m, ft·lb)
	<5> to <15>	8 mm	24.5 (2.5, 18.1)
	<1> to <4> <16>, <17>	10 mm	39 (4.0, 28.9)

GENERAL DESCRIPTION

MANUAL TRANSMISSION AND DIFFERENTIAL

2. DRIVE PINION ASSEMBLY

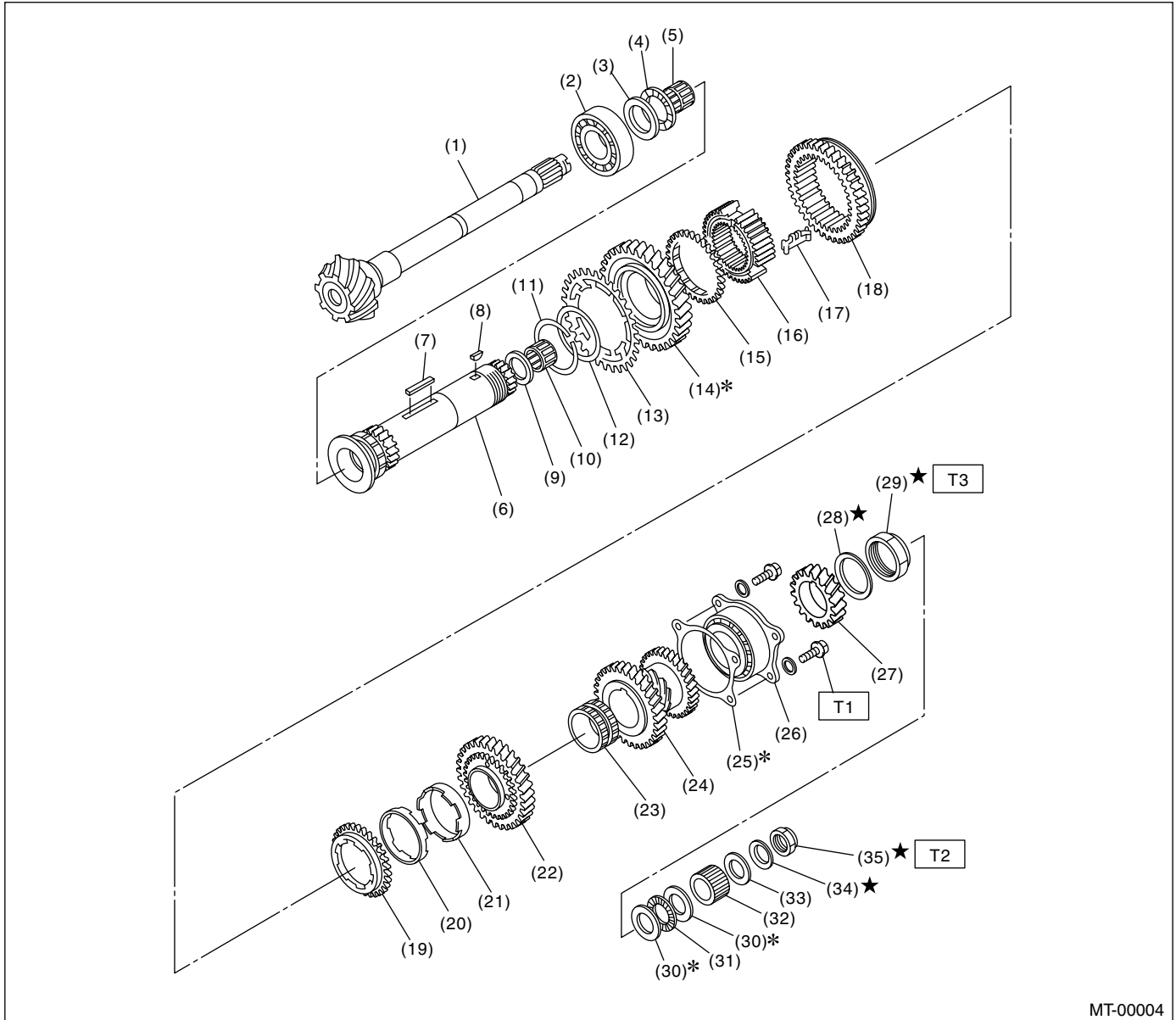

MT-00004

- | | | |
|-------------------------|-------------------------------|-------------------------------------|
| (1) Drive pinion shaft | (15) Baulk ring | (28) Lock washer |
| (2) Roller bearing | (16) 1st-2nd synchronizer hub | (29) Lock nut |
| (3) Washer | (17) Insert key | (30) Washer |
| (4) Thrust bearing | (18) Reverse driven gear | (31) Thrust bearing |
| (5) Needle bearing | (19) Outer baulk ring | (32) Differential bevel gear sleeve |
| (6) Driven shaft | (20) Synchro cone | (33) Washer |
| (7) Key | (21) Inner baulk ring | (34) Lock washer |
| (8) Woodruff key | (22) 2nd driven gear | (35) Lock nut |
| (9) Drive pinion collar | (23) 2nd driven gear bush | |
| (10) Needle bearing | (24) 3rd-4th driven gear | |
| (11) Snap ring (Outer) | (25) Driven pinion shim | |
| (12) Washer | (26) Roller bearing | |
| (13) Sub gear | (27) 5th driven gear | |
| (14) 1st driven gear | | |

Tightening torque: N·m (kgf·m, ft·lb)

T1: 30.5 (3.1, 22.5)

T2: 120 (12.2, 88.5)

T3: 260 (26.5, 191.7)

GENERAL DESCRIPTION

MANUAL TRANSMISSION AND DIFFERENTIAL

3. MAIN SHAFT ASSEMBLY

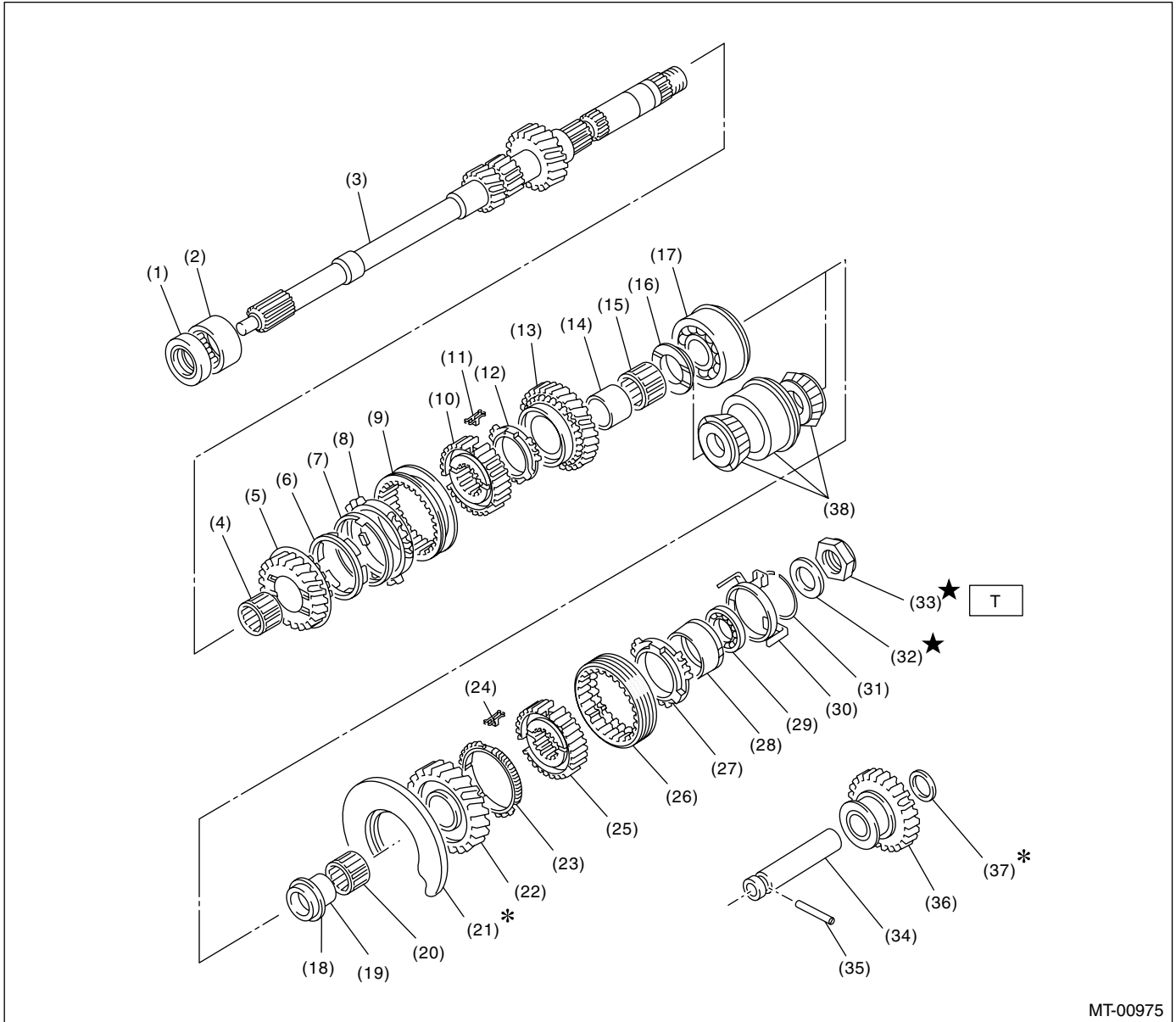

- | | | |
|----------------------------------|-------------------------------------|---|
| (1) Oil seal | (15) Needle bearing | (29) Ball bearing |
| (2) Needle bearing | (16) 4th gear thrust washer | (30) Synchro cone stopper |
| (3) Transmission main shaft | (17) Ball bearing (Non-turbo model) | (31) Snap ring |
| (4) Needle bearing | (18) 5th gear thrust washer | (32) Lock washer |
| (5) 3rd drive gear | (19) 5th needle bearing race | (33) Lock nut |
| (6) Inner baulk ring | (20) Needle bearing | (34) Reverse idler gear shaft |
| (7) 3rd synchro cone | (21) Main shaft rear plate | (35) Straight pin |
| (8) Outer baulk ring | (22) 5th drive gear | (36) Reverse idler gear |
| (9) 3rd-4th coupling sleeve | (23) 5th baulk ring | (37) Washer |
| (10) 3rd-4th synchronizer hub | (24) 5th-Rev shifting insert key | (38) Taper roller bearing (Turbo model) |
| (11) 3rd-4th shifting insert key | (25) 5th-Rev synchronizer hub | |
| (12) 4th baulk ring | (26) 5th-Rev coupling sleeve | |
| (13) 4th drive gear | (27) Rev baulk ring | |
| (14) 4th needle bearing race | (28) Rev synchro cone | |

Tightening torque: N·m (kgf·m, ft·lb)

T: 120 (12.2, 88.5)

GENERAL DESCRIPTION

MANUAL TRANSMISSION AND DIFFERENTIAL

4. SHIFTER FORK AND SHIFTER ROD

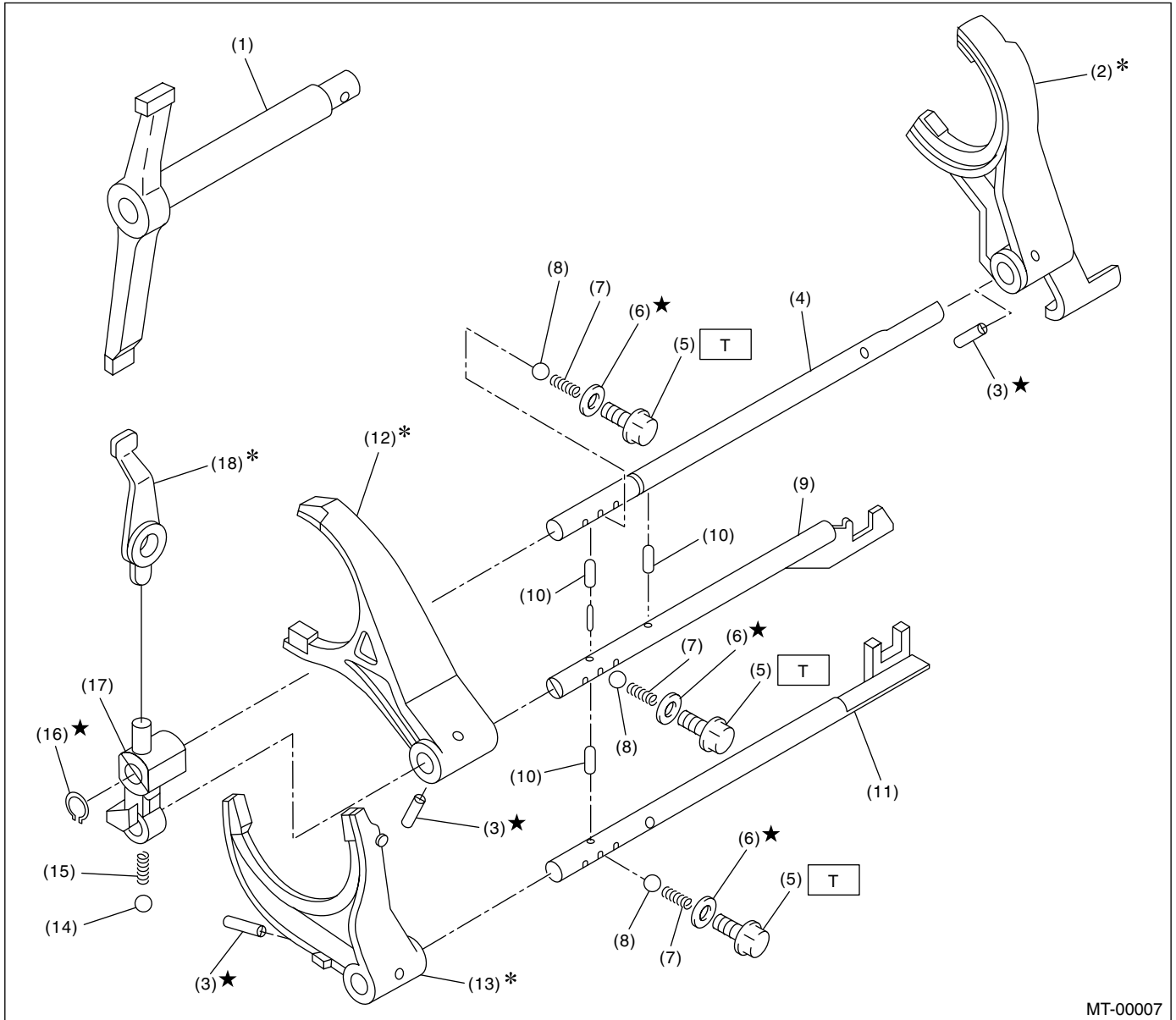

MT-00007

- | | | |
|--------------------------|---------------------------|----------------------------|
| (1) Shifter arm | (9) 3rd-4th fork rod | (17) Reverse fork rod arm |
| (2) 5th shifter fork | (10) Interlock plunger | (18) Reverse shifter lever |
| (3) Straight pin | (11) 1st-2nd fork rod | |
| (4) Reverse fork rod | (12) 3rd-4th shifter fork | |
| (5) Checking ball plug | (13) 1st-2nd shifter fork | |
| (6) Gasket | (14) Ball | |
| (7) Checking ball spring | (15) Spring | |
| (8) Ball | (16) Snap ring (Outer) | |

Tightening torque: N·m (kgf·m, ft·lb)
T: 19.5 (2.0, 14.4)

GENERAL DESCRIPTION

MANUAL TRANSMISSION AND DIFFERENTIAL

5. TRANSFER CASE AND EXTENSION

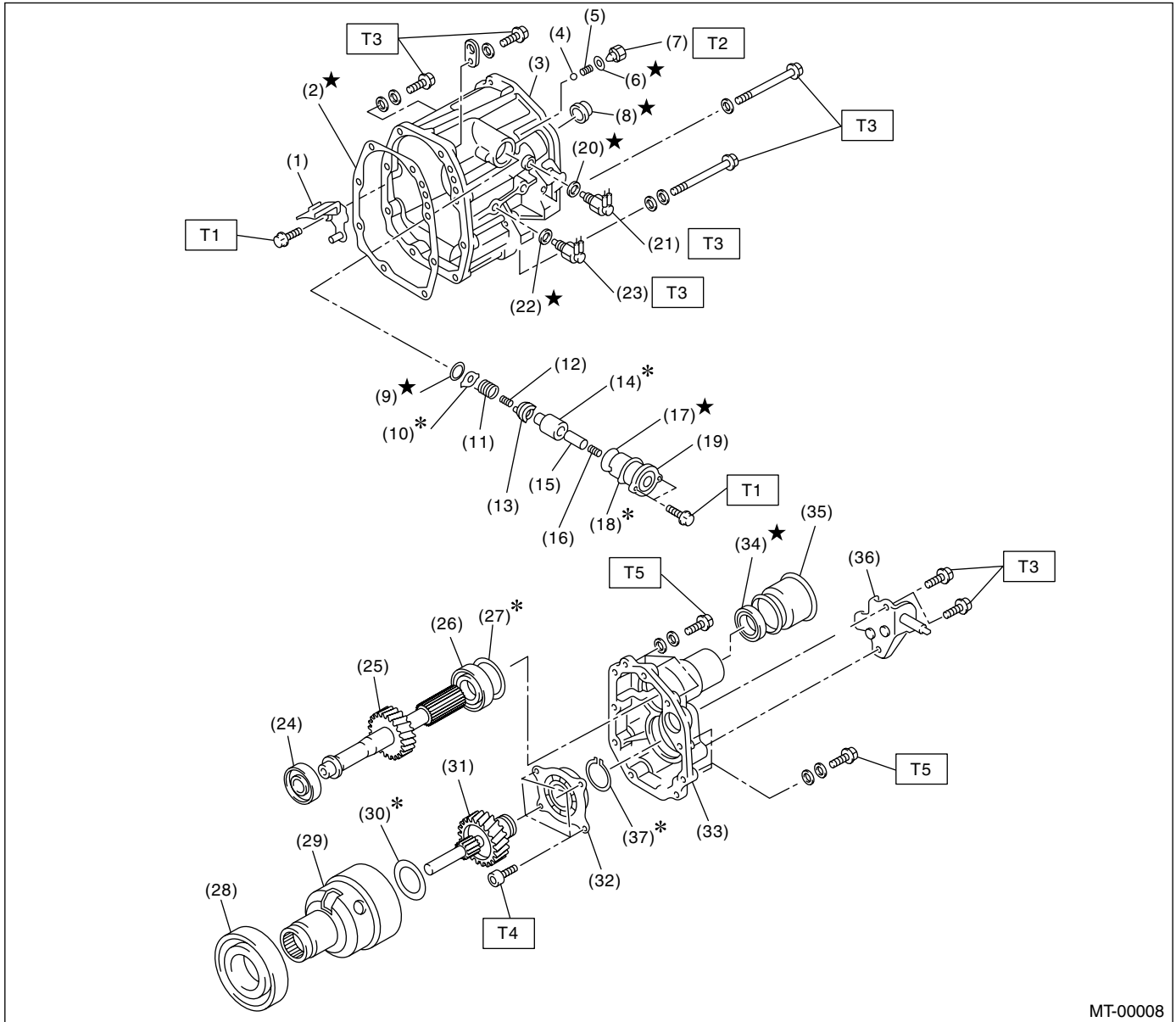

MT-00008

- | | | |
|----------------------------|----------------------------|--------------------------|
| (1) Oil guide | (16) Return spring | (31) Transfer drive gear |
| (2) Gasket | (17) O-ring | (32) Ball bearing |
| (3) Transfer case | (18) Adjusting select shim | (33) Extension case |
| (4) Ball | (19) Reverse check sleeve | (34) Oil seal |
| (5) Reverse accent spring | (20) Gasket | (35) Dust cover |
| (6) Gasket | (21) Neutral switch | (36) Shift bracket |
| (7) Plug | (22) Gasket | (37) Snap ring |
| (8) Oil seal | (23) Back-up light switch | |
| (9) Snap ring (Inner) | (24) Roller bearing | |
| (10) Reverse check plate | (25) Transfer driven gear | |
| (11) Reverse check spring | (26) Roller bearing | |
| (12) Reverse return spring | (27) Adjusting washer | |
| (13) Reverse check cam | (28) Ball bearing | |
| (14) Reverse accent shaft | (29) Center differential | |
| (15) Return spring cap | (30) Adjusting washer | |

Tightening torque: N·m (kgf·m, ft·lb)

T1: 6.4 (0.65, 4.7)

T2: 9.75 (1.0, 7.2)

T3: 25 (2.5, 18.1)

T4: 26 (2.7, 20)

T5: 40 (4.1, 29.7)

GENERAL DESCRIPTION

MANUAL TRANSMISSION AND DIFFERENTIAL

6. FRONT DIFFERENTIAL

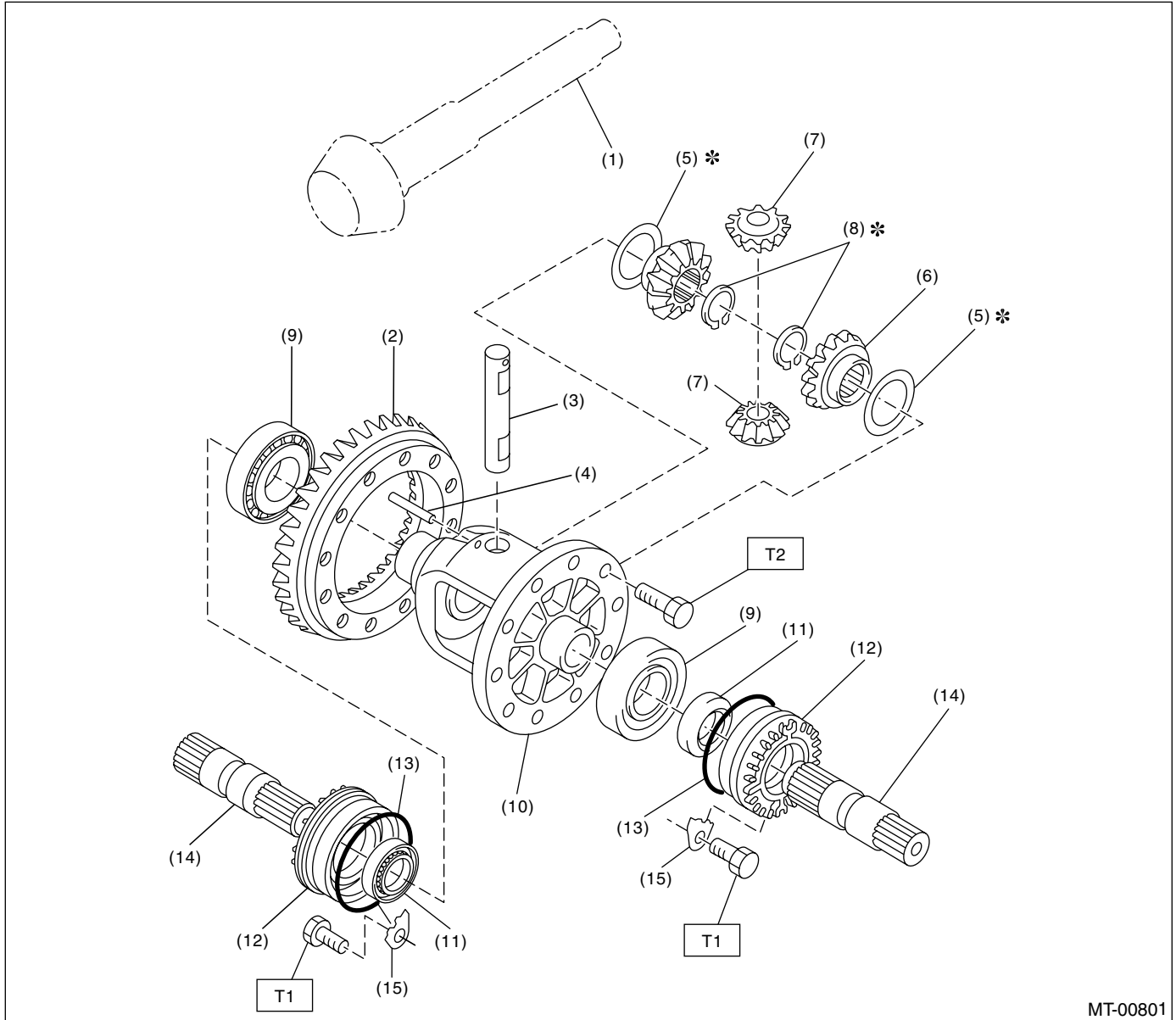

MT-00801

- | | | |
|-------------------------------|---------------------------------|--------------------------|
| (1) Drive pinion shaft | (8) Snap ring (Outer) | (15) Retainer lock plate |
| (2) Hypoid driven gear | (9) Roller bearing | |
| (3) Pinion shaft | (10) Differential case | |
| (4) Straight pin | (11) Oil seal | |
| (5) Washer | (12) Differential side retainer | |
| (6) Differential bevel gear | (13) O-ring | |
| (7) Differential bevel pinion | (14) Axle drive shaft | |

Tightening torque: N·m (kgf·m, ft·lb)

T1: 24.5 (2.5, 18.1)

T2: 62 (6.3, 45.6)

GENERAL DESCRIPTION

MANUAL TRANSMISSION AND DIFFERENTIAL

7. TRANSMISSION MOUNTING

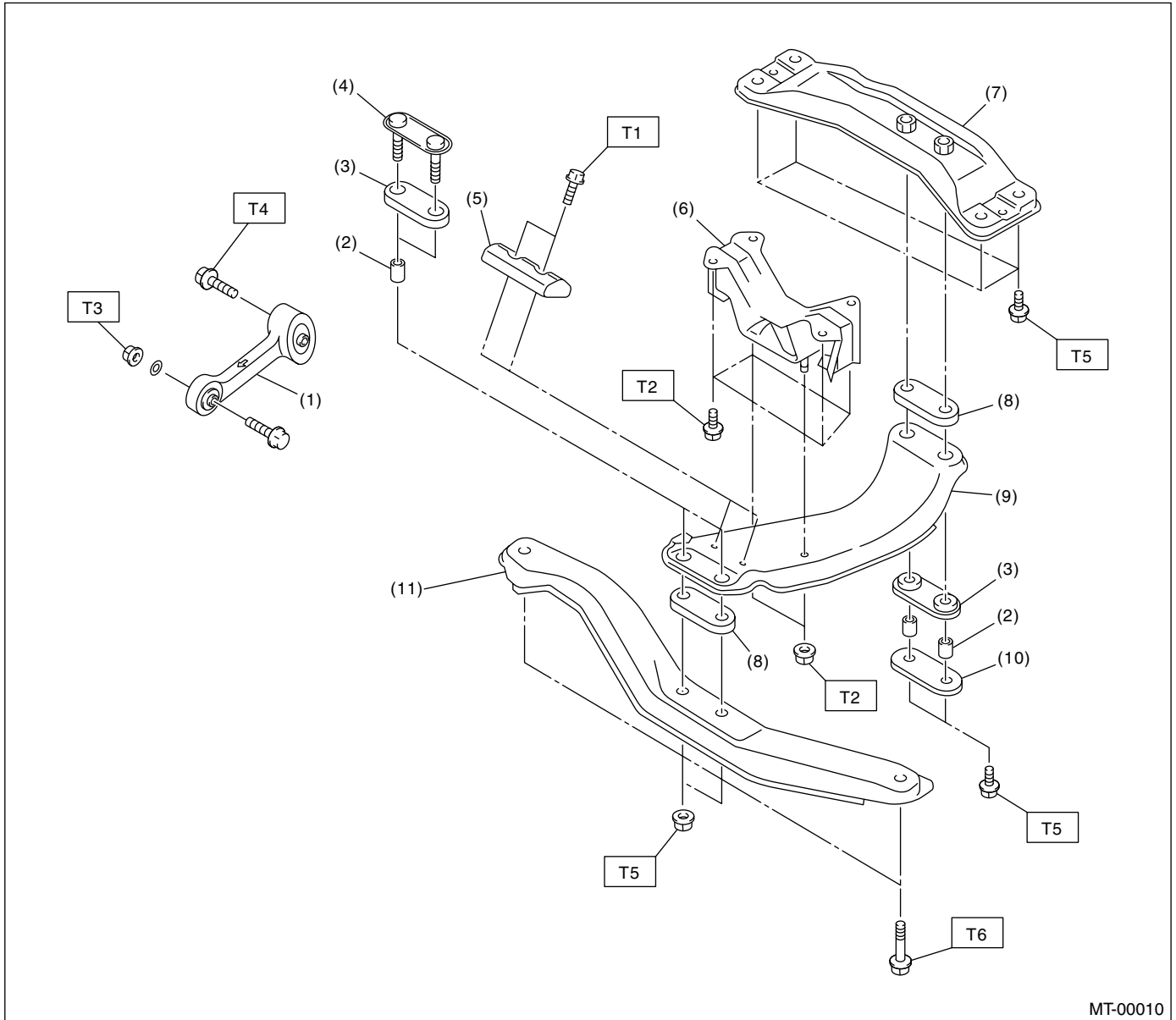

MT-00010

- | | |
|-------------------------|------------------------|
| (1) Pitching stopper | (8) Cushion D |
| (2) Spacer | (9) Center crossmember |
| (3) Cushion C | (10) Rear plate |
| (4) Front plate | (11) Front crossmember |
| (5) Dynamic damper | |
| (6) Rear cushion rubber | |
| (7) Rear crossmember | |

Tightening torque: N-m (kgf-m, ft-lb)

T1: 7.5 (0.76, 5.5)

T2: 35 (3.6, 26)

T3: 50 (5.1, 37)

T4: 58 (5.9, 43)

T5: 70 (7.1, 51)

T6: 140 (14.3, 103)

GENERAL DESCRIPTION

MANUAL TRANSMISSION AND DIFFERENTIAL

C: CAUTION

- Wear working clothing, including a cap, protective goggles, and protective shoes during operation.
- Remove contamination including dirt and corrosion before removal, installation, and disassembly.
- Keep the disassembled parts in order and protect them from dust or dirt.
- Before removal, installation or disassembly, be sure to clarify the failure. Avoid unnecessary removal, installation, disassembly and replacement.
- When disassembling the case and other light alloy parts, use a plastic hammer to force it apart. Do not pry it apart with a screwdriver or other tool.
- Be careful not to burn your hands, because each part on the vehicle is hot after running.
- Use SUBARU genuine gear oil, grease etc. or the equivalent. Do not mix gear oil, grease etc. with that of another grade or from other manufacturers.

- Be sure to tighten fasteners including bolts and nuts to the specified torque.
- Place shop jacks or safety stands at the specified points.
- Apply gear oil onto sliding or revolution surfaces before installation.
- Replace deformed or otherwise damaged snap rings with new ones.
- Before installing O-rings or oil seals, apply sufficient amount of gear oil to avoid damage and deformation.
- Be careful not to incorrectly install or fail to install O-rings, snap rings and other such parts.
- Before securing a part on a vise, place cushioning material such as wood blocks, aluminum plate, or shop cloth between the part and the vise.
- Avoid damaging the mating surface of the case.
- Before applying sealant, completely remove the old seal.

D: PREPARATION TOOL

1. SPECIAL TOOLS

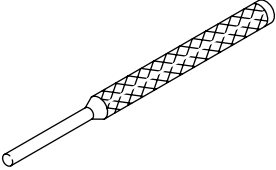
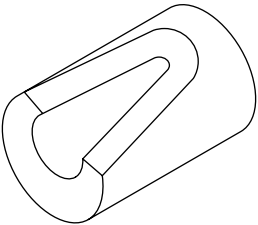
ILLUSTRATION	TOOL NUMBER	DESCRIPTION	REMARKS
 <p>ST-398791700</p>	398791700	REMOVER	Used for removing and installing spring pin (6 mm).
 <p>ST-399411700</p>	399411700	ACCENT BALL INSTALLER	Used for installing reverse shifter rail arm.

GENERAL DESCRIPTION

MANUAL TRANSMISSION AND DIFFERENTIAL

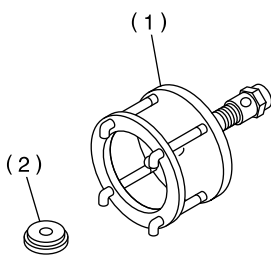
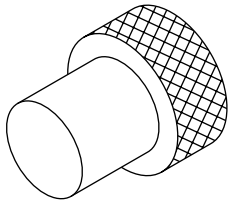
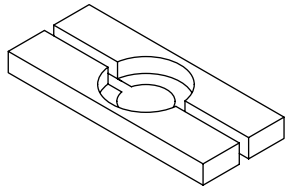
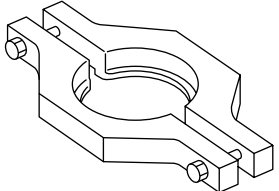
ILLUSTRATION	TOOL NUMBER	DESCRIPTION	REMARKS
 <p style="text-align: center;">ST-899524100</p>	899524100	PULLER SET	Used for removing and installing roller bearing (Differential). (1) PULLER (2) CAP
 <p style="text-align: center;">ST-399780104</p>	399780104	WEIGHT	Used for measuring preload on roller bearing.
 <p style="text-align: center;">ST-498077000</p>	498077000	REMOVER	Used for removing roller bearing of drive pinion shaft.
 <p style="text-align: center;">ST-498077300</p>	498077300	CENTER DIFFERENTIAL BEARING REMOVER	Used for removing the center differential cover ball bearing.

GENERAL DESCRIPTION

MANUAL TRANSMISSION AND DIFFERENTIAL

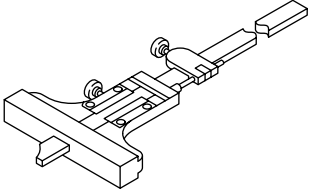
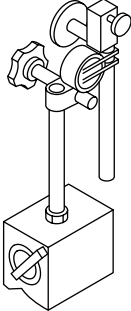
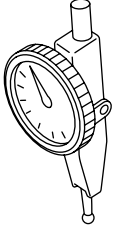
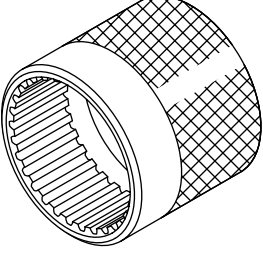
ILLUSTRATION	TOOL NUMBER	DESCRIPTION	REMARKS
 <p style="text-align: center;">ST-498147000</p>	498147000	DEPTH GAUGE	Used for adjusting main shaft axial end play.
 <p style="text-align: center;">ST-498247001</p>	498247001	MAGNET BASE	<ul style="list-style-type: none"> • Used for measuring backlash between side gear and pinion, and hypoid gear. • Used with DIAL GAUGE (498247100).
 <p style="text-align: center;">ST-498247100</p>	498247100	DIAL GAUGE	<ul style="list-style-type: none"> • Used for measuring backlash between side gear and pinion, and hypoid gear. • Used with MAGNET BASE (498247001).
 <p style="text-align: center;">ST-498427100</p>	498427100	STOPPER	Used for securing the drive pinion shaft assembly and driven gear assembly when removing the drive pinion shaft assembly lock nut.

GENERAL DESCRIPTION

MANUAL TRANSMISSION AND DIFFERENTIAL

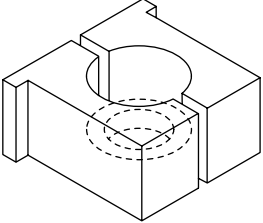
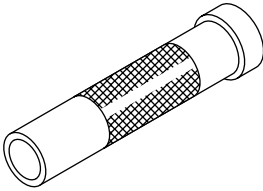
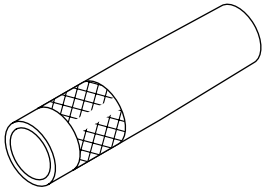
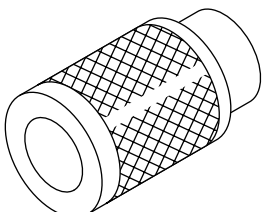
ILLUSTRATION	TOOL NUMBER	DESCRIPTION	REMARKS
 <p data-bbox="337 562 472 590">ST-498937000</p>	498937000	TRANSMISSION HOLDER	Used for removing and installing transmission main shaft lock nut.
 <p data-bbox="337 961 472 989">ST-499277100</p>	499277100	BUSH 1-2 INSTALLER	<ul style="list-style-type: none"> • Used for installing 1st driven gear thrust plate and 1st-2nd driven gear bush. • Used for installing roller bearing outer races to differential case.
 <p data-bbox="337 1365 472 1392">ST-499277200</p>	499277200	INSTALLER	Used for press-fitting the 2nd driven gear, roller bearings and 5th driven gear onto the driven shaft.
 <p data-bbox="337 1764 472 1791">ST-499757002</p>	499757002	INSTALLER	<ul style="list-style-type: none"> • Used for installing snap ring (OUT 25) and ball bearing (25 × 26 × 17). • Used for installing bearing cone of transfer driven gear (extension core side).

GENERAL DESCRIPTION

MANUAL TRANSMISSION AND DIFFERENTIAL

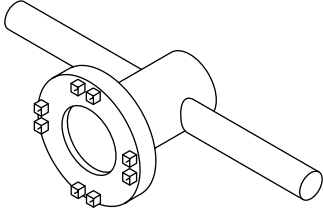
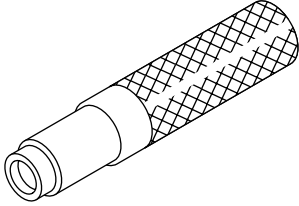
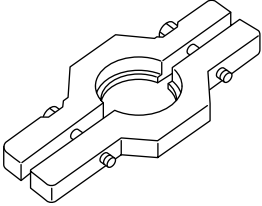
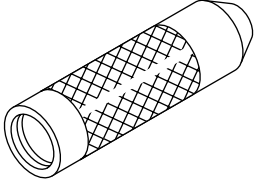
ILLUSTRATION	TOOL NUMBER	DESCRIPTION	REMARKS
 <p style="text-align: center;">ST-499787000</p>	499787000	WRENCH ASSY	Used for removing and installing differential side retainer.
 <p style="text-align: center;">ST-499827000</p>	499827000	PRESS	Used for installing speedometer oil seal when installing speedometer cable to transmission.
 <p style="text-align: center;">ST-499857000</p>	499857000	5TH DRIVEN GEAR REMOVER	Used for removing 5th driven gear.
 <p style="text-align: center;">ST-499877000</p>	499877000	RACE 4-5 INSTALLER	<ul style="list-style-type: none"> • Used for installing 4th needle bearing race and ball bearing onto transmission main shaft. • Used with REMOVER (899714110).

GENERAL DESCRIPTION

MANUAL TRANSMISSION AND DIFFERENTIAL

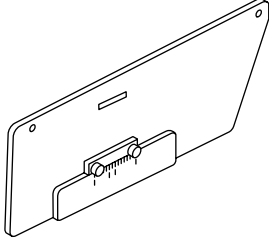
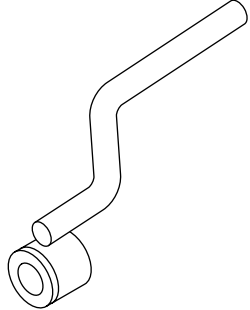
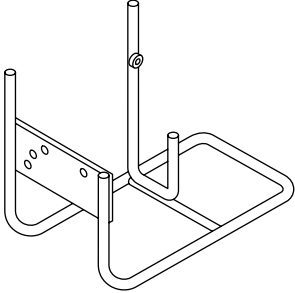
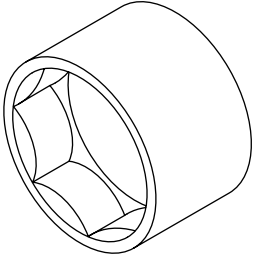
ILLUSTRATION	TOOL NUMBER	DESCRIPTION	REMARKS
 <p data-bbox="337 562 474 590">ST-499917500</p>	499917500	DRIVE PINION GAUGE ASSY	Used for adjusting drive pinion shim.
 <p data-bbox="337 968 474 995">ST-499927100</p>	499927100	HANDLE	Used for fitting transmission main shaft.
 <p data-bbox="337 1371 474 1398">ST-499937100</p>	499937100	TRANSMISSION STAND SET	Stand used for transmission disassembly and assembly.
 <p data-bbox="337 1770 474 1797">ST-499987003</p>	499987003	SOCKET WRENCH (35)	Used for removing and installing driven pinion lock nut and main shaft lock nut.

GENERAL DESCRIPTION

MANUAL TRANSMISSION AND DIFFERENTIAL

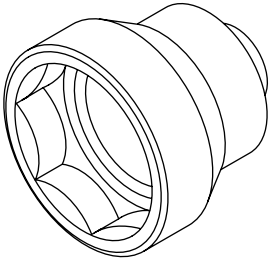
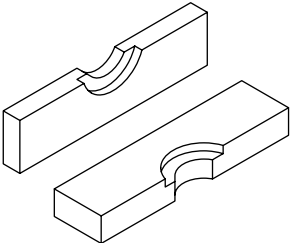
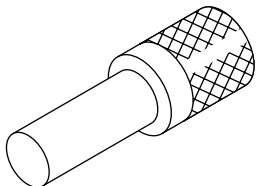
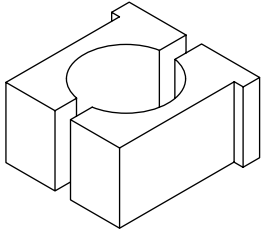
ILLUSTRATION	TOOL NUMBER	DESCRIPTION	REMARKS
 <p style="text-align: center;">ST-499987300</p>	499987300	SOCKET WRENCH (50)	Used for removing and installing driven gear assembly lock nut.
 <p style="text-align: center;">ST-899714110</p>	899714110	REMOVER	Used for fixing transmission main shaft, drive pinion and rear drive shaft.
 <p style="text-align: center;">ST-899864100</p>	899864100	REMOVER	Used for removing parts on transmission main shaft and drive pinion.
 <p style="text-align: center;">ST-899884100</p>	899884100	HOLDER	Used for tightening lock nut on sleeve.

GENERAL DESCRIPTION

MANUAL TRANSMISSION AND DIFFERENTIAL

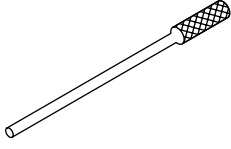
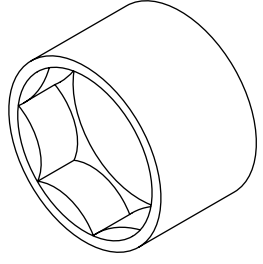
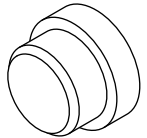
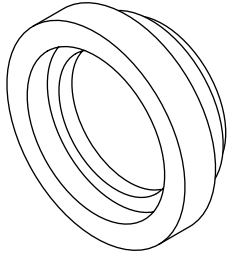
ILLUSTRATION	TOOL NUMBER	DESCRIPTION	REMARKS
 ST-899904100	899904100	REMOVER	Used for removing and installing straight pin.
 ST-899988608	899988608	SOCKET WRENCH (27)	Used for removing and installing drive pinion lock nut.
 ST-398497701	398497701	ADAPTER	<ul style="list-style-type: none">• Used for installing roller bearing onto differential case.• Used with INSTALLER (499277100).
 ST-499587000	499587000	INSTALLER	Used for installing driven gears to driven shaft.

GENERAL DESCRIPTION

MANUAL TRANSMISSION AND DIFFERENTIAL

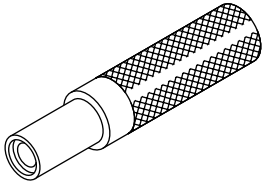
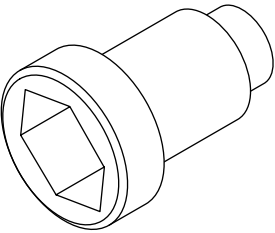
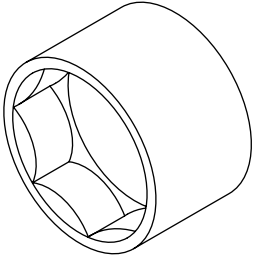
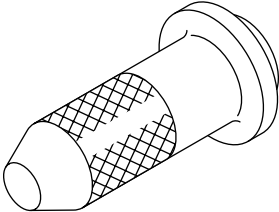
ILLUSTRATION	TOOL NUMBER	DESCRIPTION	REMARKS
 ST-899824100	899824100	PRESS	Used for installing speedometer shaft oil seal.
 ST-499987100	499987100	SOCKET WRENCH (35)	Used for removing and installing drive pinion lock nut.
 ST-899984103	899984103	SOCKET WRENCH (35)	Used for removing and installing drive pinion lock nut.
 ST-498057300	498057300	INSTALLER	Used for installing extension oil seal.

GENERAL DESCRIPTION

MANUAL TRANSMISSION AND DIFFERENTIAL

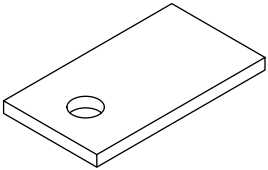
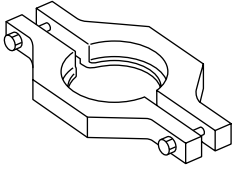
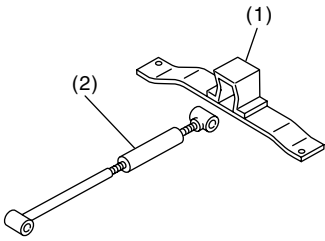
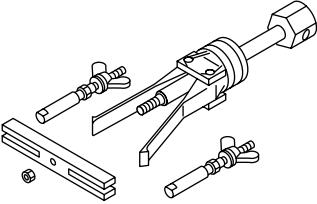
ILLUSTRATION	TOOL NUMBER	DESCRIPTION	REMARKS
 <p data-bbox="337 562 472 590">ST-498255400</p>	498255400	PLATE	Used for measuring backlash.
 <p data-bbox="337 963 472 991">ST-498077400</p>	498077400	SYNCHRONIZER CONE REMOVER	<ul style="list-style-type: none"> • Used for removing synchronizer cone of main shaft. • Used for removing 5th driven gear of drive pinion shaft.
 <p data-bbox="329 1367 472 1394">ST41099AA000</p>	41099AA000	ENGINE SUPPORT BRACKET	Used for supporting engine. (1) Engine support bracket (41099AA010) (2) Engine support (41099AA020)
 <p data-bbox="337 1770 472 1797">ST-398527700</p>	398527700	PULLER ASSY	Used for removing extension case roller bearing.

GENERAL DESCRIPTION

MANUAL TRANSMISSION AND DIFFERENTIAL

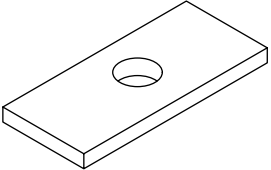
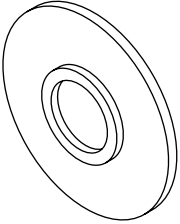
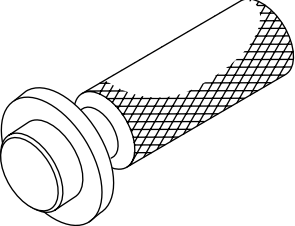
ILLUSTRATION	TOOL NUMBER	DESCRIPTION	REMARKS
 ST-398643600	398643600	GAUGE	Used for measuring total end play, extension end play and drive pinion height.
 ST-398177700	38177700	INSTALLER	<ul style="list-style-type: none"> • Used for installing bearing cone of transfer driven gear (transfer case side). • Used for installing ball bearing of transfer drive gear.
 ST-499797000	499797000	INSTALLER	Used for installing differential side retainer oil seal.

2. GENERAL PURPOSE TOOLS

TOOL NAME	REMARKS
Circuit Tester	Used for measuring resistance, voltage and ampere.