

18. Transmission Case

A: REMOVAL

- 1) Remove the manual transmission assembly from vehicle. <Ref. to 6MT-35, REMOVAL, Manual Transmission Assembly.>
- 2) Prepare the transmission for overhaul. <Ref. to 6MT-40, Preparation for Overhaul.>
- 3) Remove the oil pipe, neutral position switch, back-up light switch and harness. <Ref. to 6MT-42, REMOVAL, Oil Pipe.>, <Ref. to 6MT-45, REMOVAL, Neutral Position Switch.>, <Ref. to 6MT-43, REMOVAL, Back-up Light Switch.>
- 4) Remove the extension case. <Ref. to 6MT-47, REMOVAL, Extension Case.>
- 5) Remove the transfer driven gear. <Ref. to 6MT-58, REMOVAL, Transfer Driven Gear.>
- 6) Remove the center differential. <Ref. to 6MT-60, REMOVAL, Center Differential.>
- 7) Remove the oil pump. <Ref. to 6MT-61, REMOVAL, Oil Pump.>
- 8) Remove the shim and spacer of driven gear assembly.

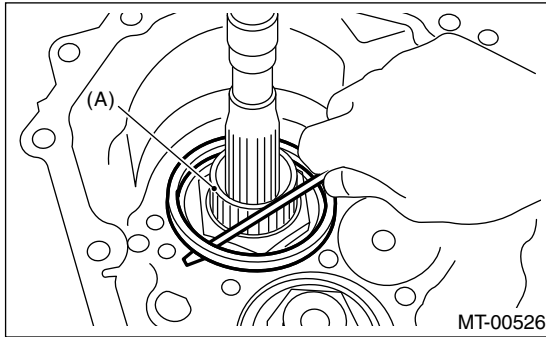

(A) Driven gear assembly

- 9) Remove the snap ring.

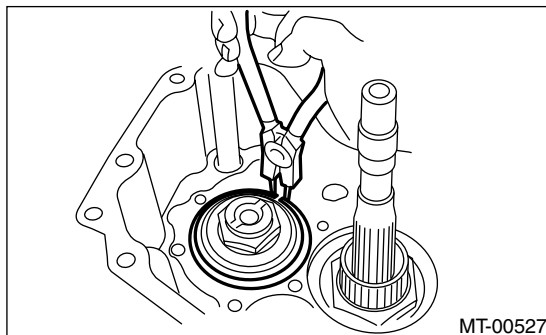

- 10) Remove the pilot bolt.

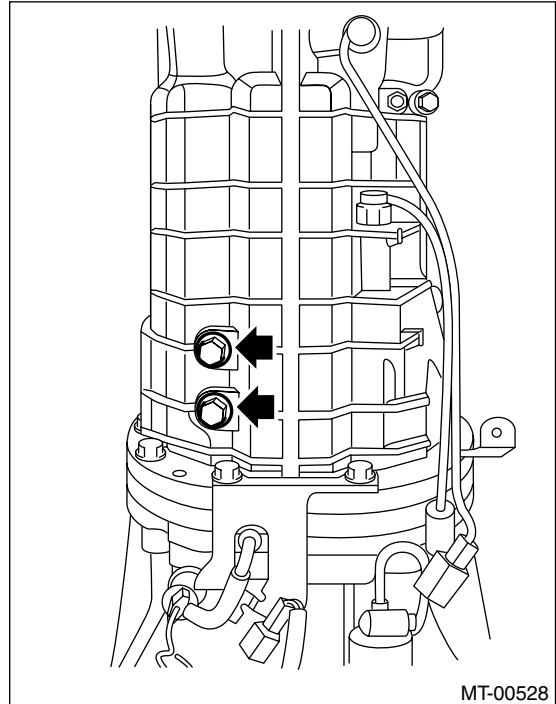

- 11) Remove the holder reverse bolt.

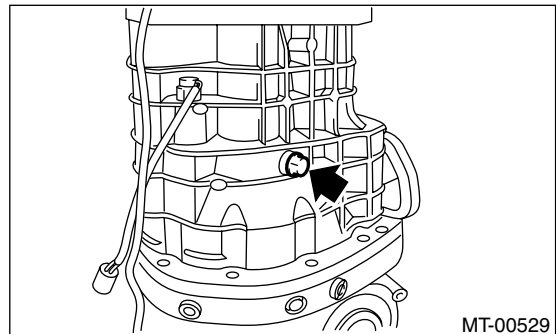

- 12) Remove the transmission case.

NOTE:

If the oil guide catches on shift fork, the transmission case may be difficult to be removed. Move the oil guide right and left to remove. Do not pull the transmission case by force.

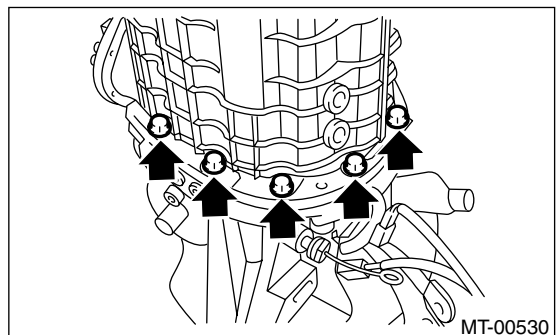

- 13) Completely remove the remaining liquid gasket on transmission case and adapter plate.

TRANSMISSION CASE

MANUAL TRANSMISSION AND DIFFERENTIAL

B: INSTALLATION

1) Make sure that each shifter fork and interlock block is shifted to neutral position. If not, shift to neutral position.

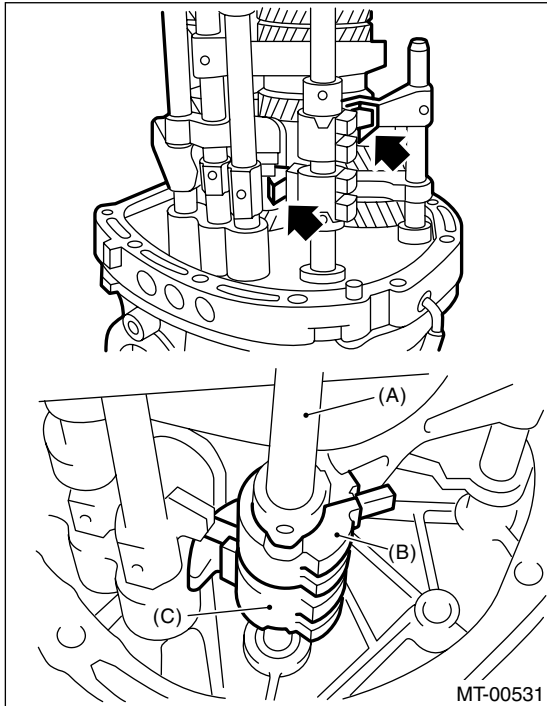

- (A) Striking rod
- (B) Reverse interlock block
- (C) Interlock block

2) Apply liquid gasket to the adapter plate.

Liquid gasket:
THREE BOND 1215 (Part No. 004403007)

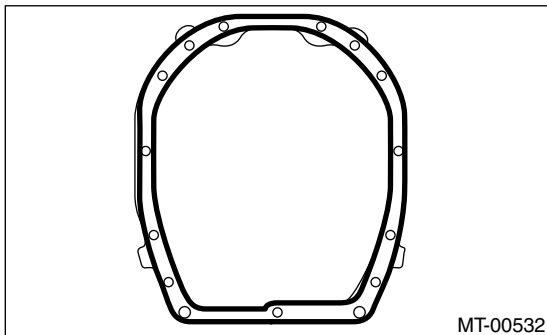

3) Install the transmission case.

4) Make sure the interlock block and reverse interlock block are aligned in neutral position by inspecting through the pilot bolt installation hole. If not aligned, remove the transmission case, then shift each shifter fork and interlock block to neutral position.

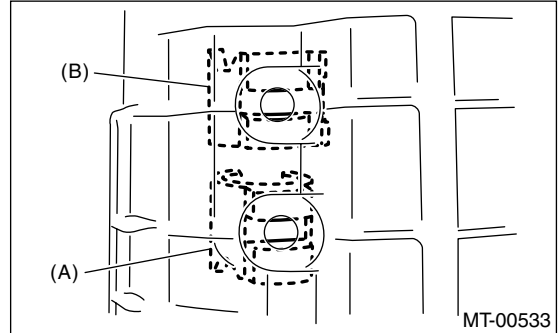

- (A) Interlock block
- (B) Reverse interlock block

5) Using a new gasket, install the pilot bolts temporarily.

6) Tighten the transmission case with bolts and nuts.

Tightening torque:
50 N·m (5.1 kgf-m, 36.9 ft-lb)

7) Tighten the pilot bolts.

Tightening torque:
34 N·m (3.5 kgf-m, 25.1 ft-lb)

8) Tighten the holder reverse bolt.

Tightening torque:
25 N·m (2.5 kgf-m, 18.1 ft-lb)

TRANSMISSION CASE

MANUAL TRANSMISSION AND DIFFERENTIAL

9) Install the snap ring, washer and collar of driven gear assembly.

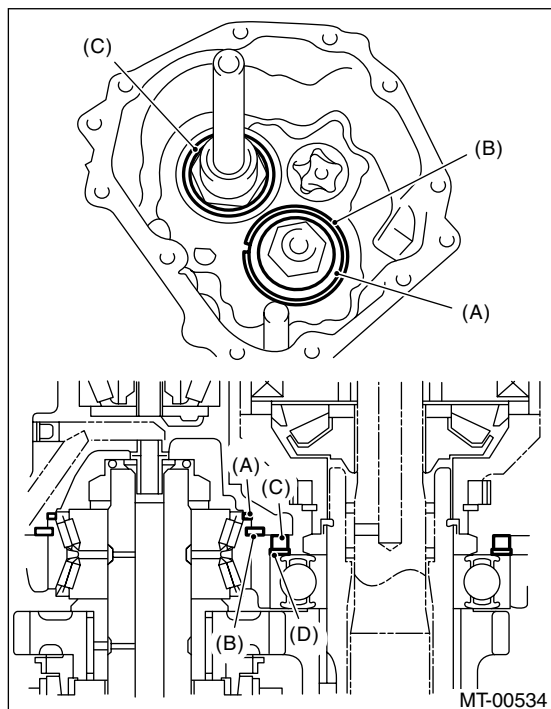

- (A) Washer
- (B) Snap ring
- (C) Collar
- (D) Washer

10) Install the oil pump. <Ref. to 6MT-62, INSTALLATION, Oil Pump.>

11) Install the center differential. <Ref. to 6MT-60, INSTALLATION, Center Differential.>

12) Install the transfer driven gear. <Ref. to 6MT-58, INSTALLATION, Transfer Driven Gear.>

13) Install the extension case. <Ref. to 6MT-47, INSTALLATION, Extension Case.>

14) Install the oil pipe, neutral position switch, back-up light switch and harness. <Ref. to 6MT-42, INSTALLATION, Oil Pipe.>, <Ref. to 6MT-45, INSTALLATION, Neutral Position Switch.>, <Ref. to 6MT-43, INSTALLATION, Back-up Light Switch.>

15) Install the manual transmission assembly to vehicle. <Ref. to 6MT-37, INSTALLATION, Manual Transmission Assembly.>

C: DISASSEMBLY

1) Remove the oil pipe and oil guide.

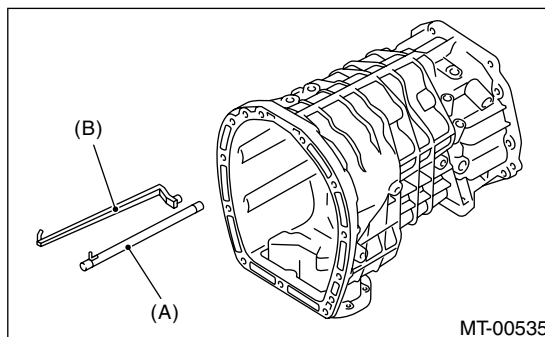

- (A) Oil pipe
- (B) Oil guide

2) Remove the bolt, and then remove the O-ring, relief spring and relief valve.

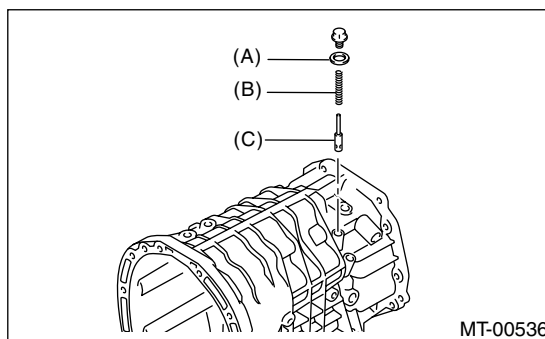

- (A) O-ring
- (B) Relief valve spring
- (C) Relief valve

3) Remove the bolt, and then remove the O-ring, valve spring and ball.

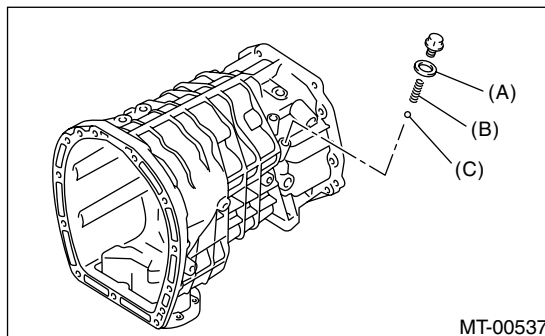

- (A) O-ring
- (B) Valve spring
- (C) Ball

TRANSMISSION CASE

MANUAL TRANSMISSION AND DIFFERENTIAL

4) Remove the harness bracket.

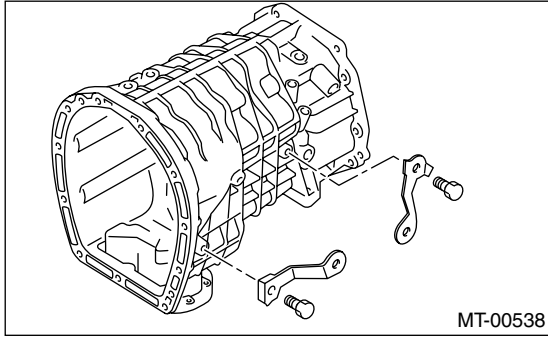

5) Remove the oil pan.

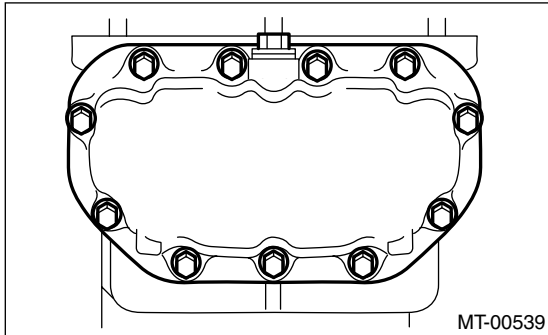

6) Completely remove the remaining liquid gasket on transmission case and oil pan.

7) Remove the oil pan magnet, and then remove the oil strainer.

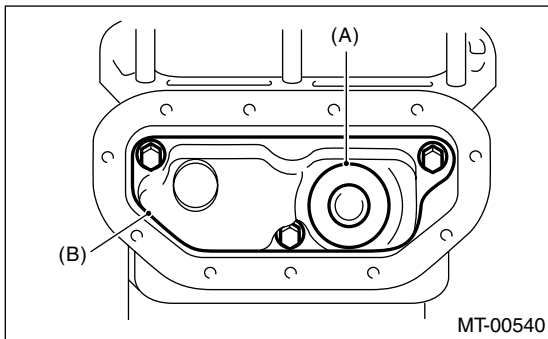

- (A) Oil pan magnet
- (B) Oil strainer

D: ASSEMBLY

1) Install the oil strainer and magnet.

Tightening torque:

10 N·m (1.0 kgf-m, 7.4 ft-lb)

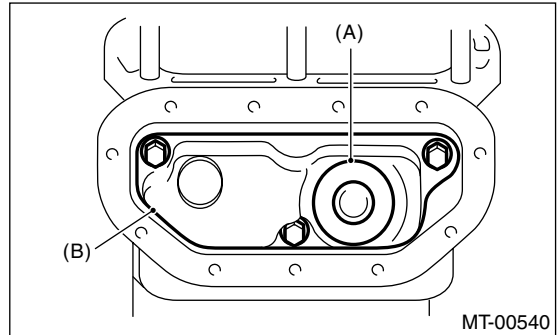

- (A) Oil pan magnet
- (B) Oil strainer

2) Apply liquid gasket to the oil pan.

Liquid gasket:

THREE BOND 1215 (Part No. 004403007)

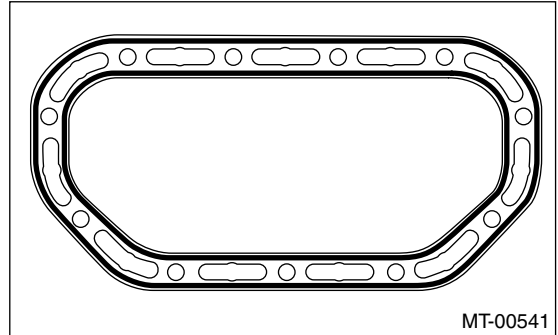

3) Install the oil pan.

Tightening torque:

6.4 N·m (0.65 kgf-m, 4.7 ft-lb)

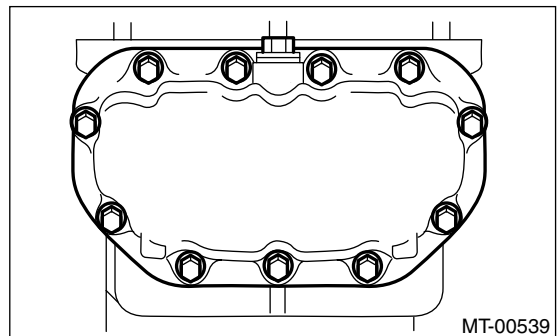

4) Install the relief valve, relief valve spring and new O-ring.

TRANSMISSION CASE

MANUAL TRANSMISSION AND DIFFERENTIAL

5) Install the ball, valve spring and new O-ring.

Tightening torque:

T1: 13 N·m (1.3 kgf-m, 9.6 ft-lb)

T2: 16 N·m (1.6 kgf-m, 11.8 ft-lb)

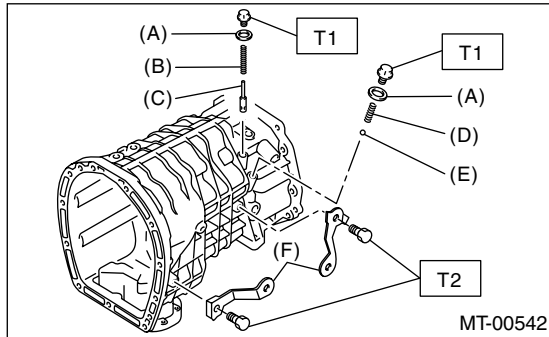

- (A) O-ring
- (B) Relief valve spring
- (C) Relief valve
- (D) Valve spring
- (E) Ball
- (F) Harness bracket

E: INSPECTION

- 1) Completely remove with shop cloth if sludge is adhered to the oil pan magnet.
- 2) Make sure there is no clog on the oil strainer. If clogged, remove clog or replace the oil strainer.
- 3) Make sure there is no damage on each parts.
Replace damaged parts with new parts.