

3. Front Axle

A: REMOVAL

- 1) Lift-up the vehicle and remove the front wheels.
- 2) Unlock the axle nut.

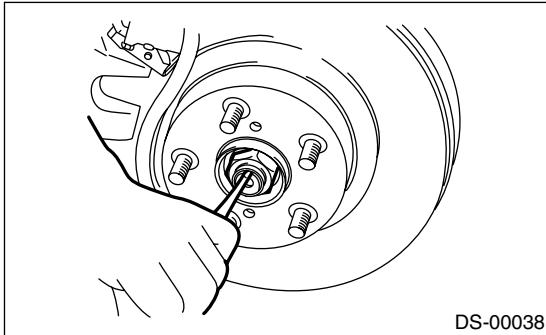

- 3) Remove the axle nut using a socket wrench while depressing the brake pedal.

CAUTION:

Remove the axle nut with vehicle weight not applied on axle. Failure to follow this rule may damage the wheel bearings.

- 4) Remove the stabilizer link.

SEDAN:

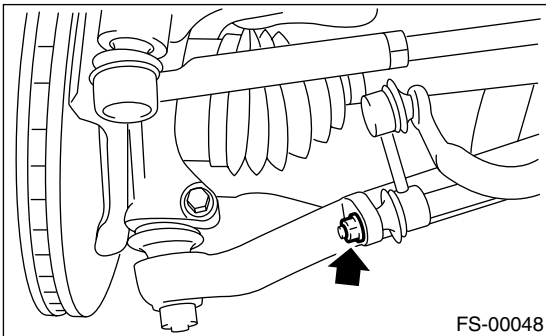

WAGON:

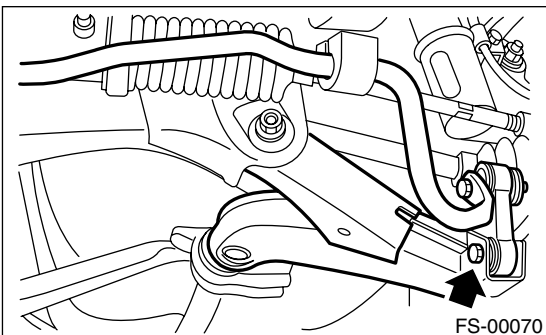

- 5) Remove the disc brake caliper from housing, and suspend it from strut using a wire.

- 6) Remove the disc rotor from hub.

NOTE:

If the disc rotor seizes up within hub, drive disc rotor out by installing an 8-mm bolt in screw hole on rotor.

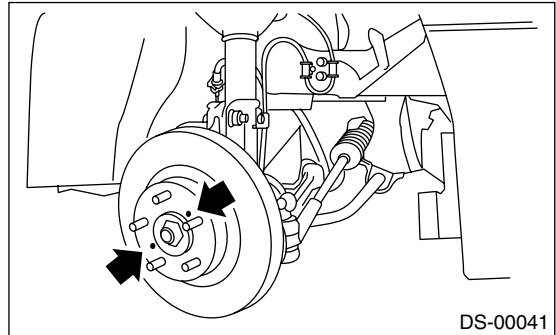

- 7) Remove the cotter pin and castle nut which secure tie-rod end to housing knuckle arm.

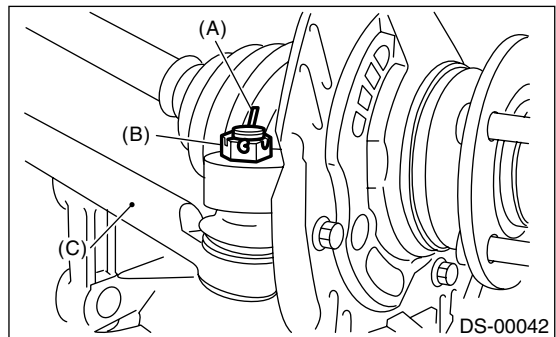

- (A) Cotter pin
- (B) Castle nut
- (C) Tie-rod

- 8) Using a puller, remove the tie-rod ball joint from knuckle arm.

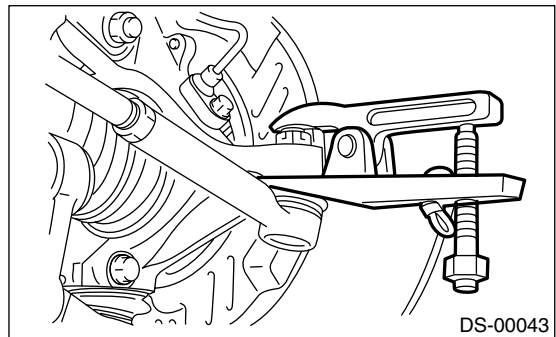

FRONT AXLE

DRIVE SHAFT SYSTEM

9) Remove the ABS wheel speed sensor assembly and harness.

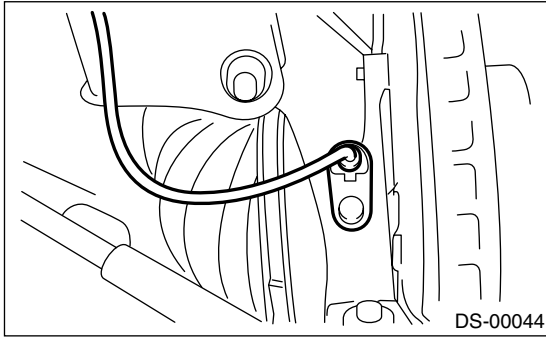

10) Remove the transverse link ball joint from housing.

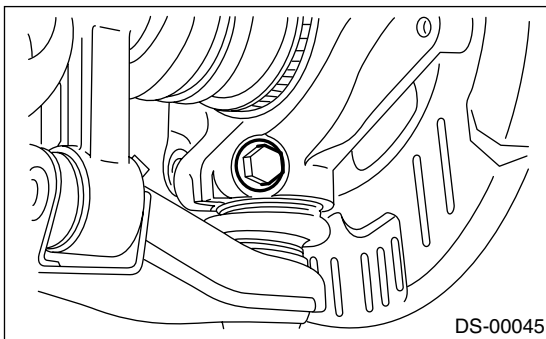

11) Remove the front drive shaft assembly from hub. If it is hard to remove, use the STs.

ST1 926470000 AXLE SHAFT PULLER
ST2 927140000 AXLE SHAFT PULLER PLATE

CAUTION:

- Be sure to replace the differential side retainer oil seal at transmission side with a new one when removing the front drive shaft.
- Suspend the front drive shaft to vehicle body using a wire.

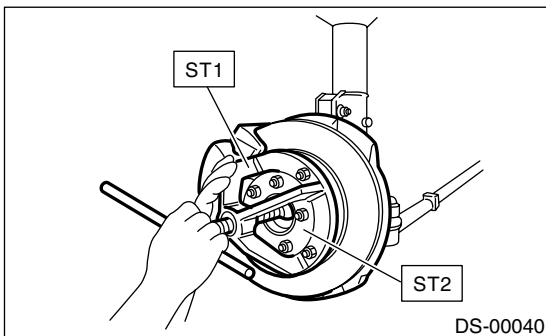

12) After scribing an alignment mark on the camber adjusting bolt head, remove the bolts which connect the housing and strut, and disconnect the housing from strut.

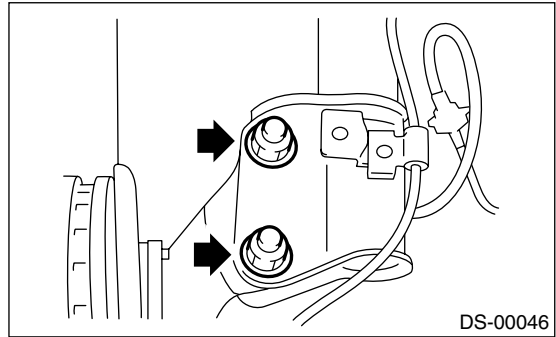

B: INSTALLATION

- 1) Temporarily tighten the front axle to front strut.
- 2) Insert the front drive shaft into front axle.
- 3) Temporarily tighten the axle nut.
- 4) Install the transverse link ball joint to housing.

Tightening torque:

50 N·m (5.1 kgf-m, 37 ft-lb)

5) While aligning the alignment mark on the camber adjusting bolt head, tighten the housing and strut using a new self-locking nut.

Tightening torque:

175 N·m (17.8 kgf-m, 129 ft-lb)

6) Connect the tie-rod end ball joint to the knuckle arm with a castle nut.

Tightening torque:

27.0 N·m (2.75 kgf-m, 19.9 ft-lb)

CAUTION:

When connecting, do not hit the cap at bottom of tie-rod with hammer.

7) Tighten the castle nut to specified torque and tighten further within 60° until the pin hole is aligned with the slot in nut. Bend the cotter pin to lock.

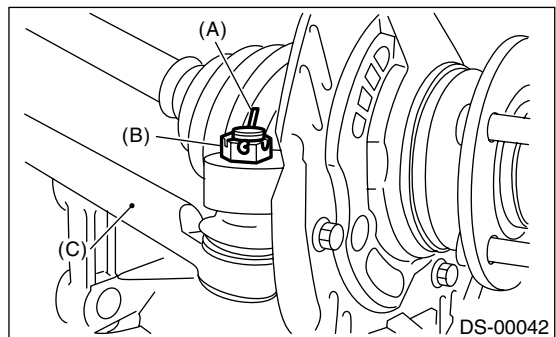

- (A) Cotter pin
- (B) Castle nut
- (C) Tie-rod

8) Install the disc rotor on hub.

9) Install the disc brake caliper on housing.

Tightening torque:

Except STi model

80 N·m (8.2 kgf·m, 59 ft·lb)

STi model

155 N·m (15.8 kgf·m, 114.3 ft·lb)

10) Connect the stabilizer link.

Tightening torque:

Except STi model

30 N·m (3.1 kgf·m, 22 ft·lb)

STi model

45 N·m (4.6 kgf·m, 33 ft·lb)

CAUTION:

Use a new self-locking nut.

11) Using the ST1 and ST2, pull the front drive shaft into place.

ST1 922431000 AXLE SHAFT INSTALLER

ST2 927390000 ADAPTER

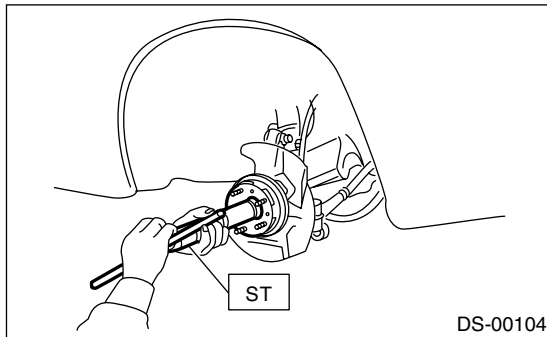

12) While depressing the brake pedal, tighten a new axle nut to specified torque and lock it securely.

Tightening torque:

220 N·m (22.4 kgf·m, 162 ft·lb)

CAUTION:

Be sure to tighten the axle nut to specified torque. Do not overtighten it as this may damage the wheel bearing.

13) After tightening the axle nut, lock it securely.

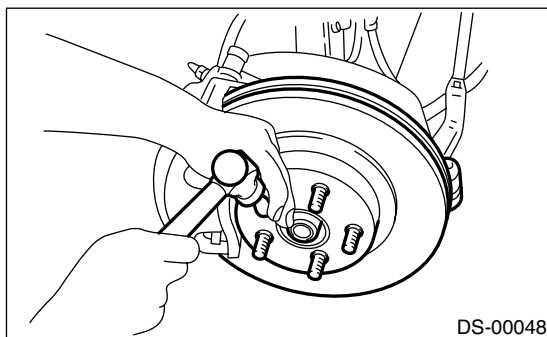

14) Install the ABS wheel speed sensor on housing.

Tightening torque:

33 N·m (3.4 kgf·m, 24.3 ft·lb)

15) Install the wheel and tighten the wheel nuts to specified torque.

Tightening torque:

90 N·m (9.2 kgf·m, 66 ft·lb)

C: DISASSEMBLY

1) Using the ST1, support the housing and hub securely.

2) Attach the ST2 to housing and drive the hub out.

ST1 927060000 HUB REMOVER

ST2 927080000 HUB STAND

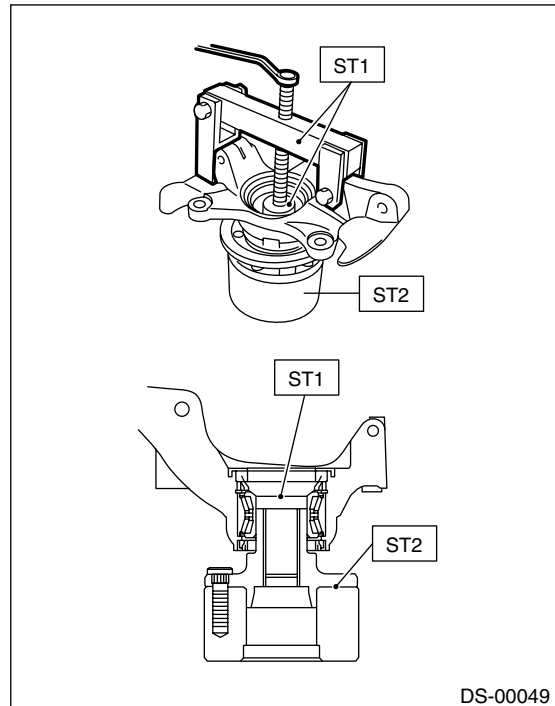

If the inner bearing race remains in hub, remove it with a suitable tool (commercially available).

NOTE:

Be careful not to scratch the polished area of hub.

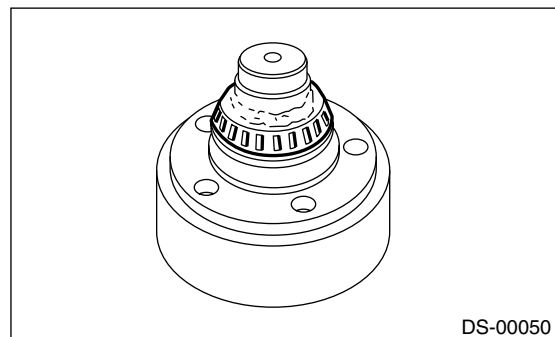

CAUTION:

Do not reuse the bearing if the hub was removed.

FRONT AXLE

DRIVE SHAFT SYSTEM

3) Remove the disc cover from housing.

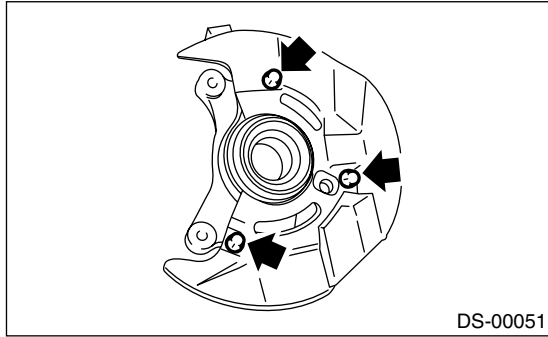

4) Using a standard screwdriver, remove the outer and inner oil seals.

5) Using a flat tip screwdriver, remove the snap ring.

NOTE:

Be careful not to damage the housing at removal.

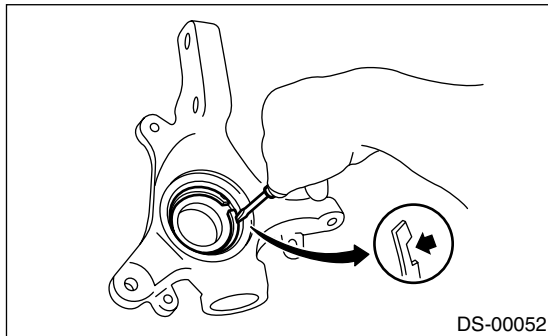

6) Using the ST1, support the housing securely.

7) Using the ST2, hold the inner race to drive out the outer race of bearing.

ST1 927400000 HOUSING STAND
ST2 927100000 BEARING PULLER

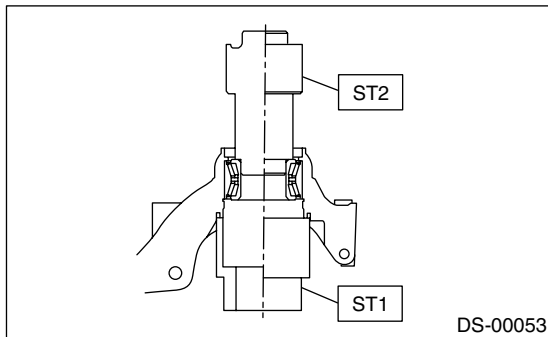

8) Using the ST and a hydraulic press, drive the hub bolts out.

ST 927080000 HUB STAND

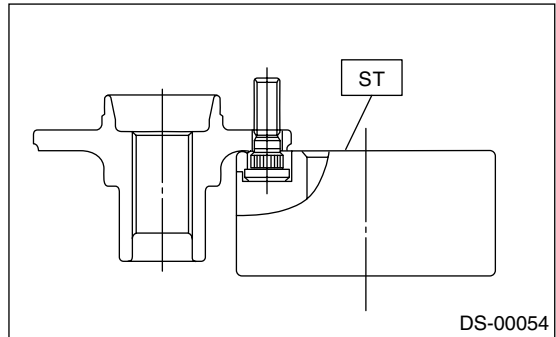

D: ASSEMBLY

NOTE:

When the hub is to be removed from housing, replace the bearing set and oil seal with new ones.

1) Attach the hub to ST securely.

ST 927080000 HUB STAND

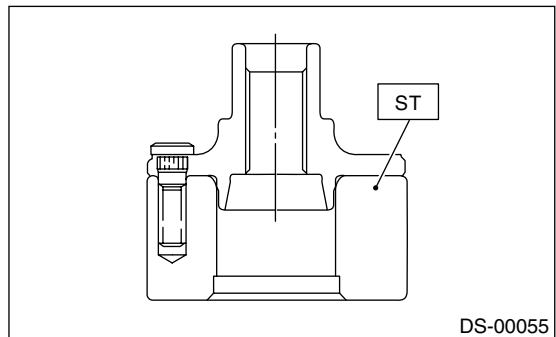

2) Using a hydraulic press, press new hub bolts until their seating surfaces contact the hub.

NOTE:

Use 12 mm (0.47 in) dia. holes in HUB STAND to prevent bolts from tilting.

3) Clean dust or foreign particles from inside of housing.

4) Using the ST1 and ST2, press a new bearing into place.

ST1 927400000 HOUSING STAND
ST2 927100000 BEARING PULLER

NOTE:

Be careful not to remove the plastic lock from inner race when installing the bearing.

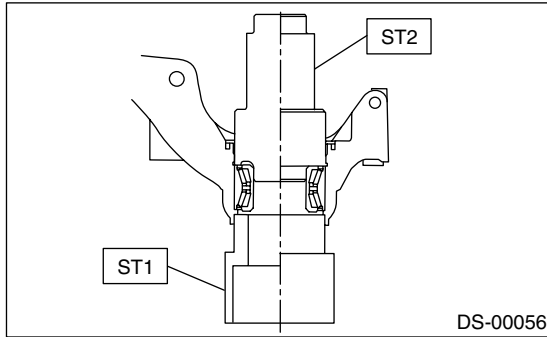

5) Using pliers, install the snap ring firmly.

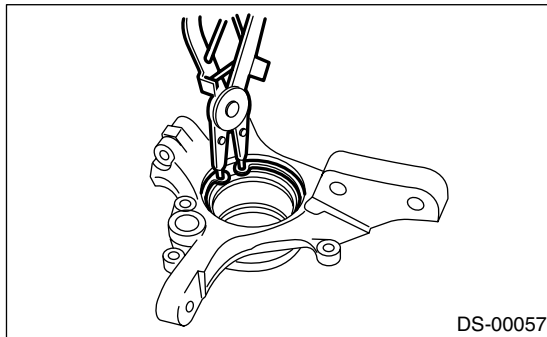

6) Using the ST1 and ST2, press the outer oil seal until it contacts the bottom of housing.

ST1 927410000 OIL SEAL INSTALLER
ST2 927400000 HOUSING STAND

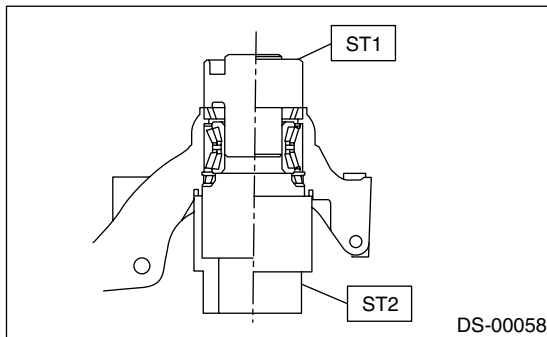

7) Using the ST1 and ST2, press the inner oil seal until it contacts the circlip.

ST1 927410000 OIL SEAL INSTALLER
ST2 927400000 HOUSING STAND

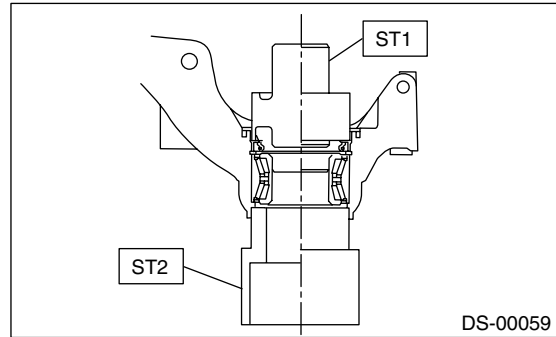

8) Invert the ST and housing.

ST 927400000 HOUSING STAND

9) Apply sufficient grease to the oil seal lip.

Specified grease:
SHELL 6459N

NOTE:

- If specified grease is not available, remove the bearing grease and apply Auto Rex A instead.
- Do not mix different types of grease.

10) Install the disc cover to housing with three bolts.

Tightening torque:

18 N·m (1.8 kgf-m, 13.0 ft-lb)

11) Attach the hub to ST1 securely.

12) Clean dust or foreign particles from the polished surface of hub.

13) Using the ST2, press the bearing into hub by driving the inner race.

ST1 927080000 HUB STAND
ST2 927120000 HUB INSTALLER

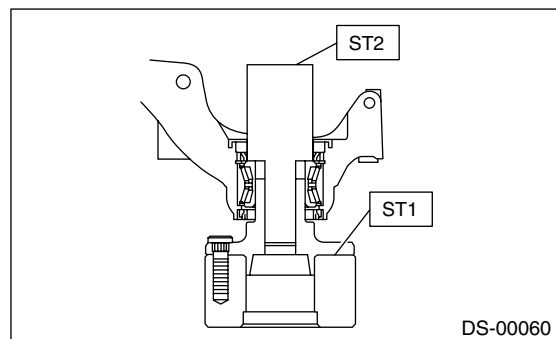

E: INSPECTION

1) Moving the front tire up and down by hand, check there is no backlash in bearing, and check the wheel rotates smoothly.

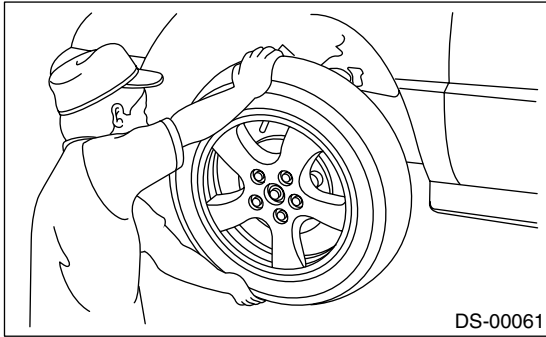

2) Inspect the lean of axis direction using a dial gauge. Replace the hub bearing if the load range exceeds the limitation.

Limit:

Maximum: 0.05mm (0.0020 in)

