

4. Rear Axle

A: REMOVAL

- 1) Disconnect the ground cable from battery.
- 2) Lift-up the vehicle, and remove the rear wheel.
- 3) Unlock the axle nut.
- 4) Remove the axle nut using a socket wrench with parking brake applied.

CAUTION:

Remove the axle nut with vehicle weight not applied on axle. Failure to follow this rule may damage the wheel bearings.

- 5) Return the parking brake lever and loosen the adjusting nut.

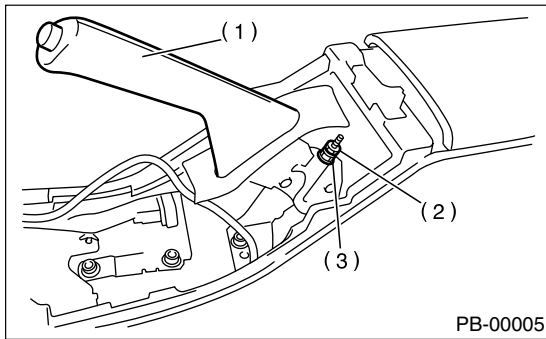

- (1) Parking brake lever
- (2) Lock nut
- (3) Adjusting nut

- 6) Remove the disc brake caliper from back plate, and suspend it from strut using a piece of wire.

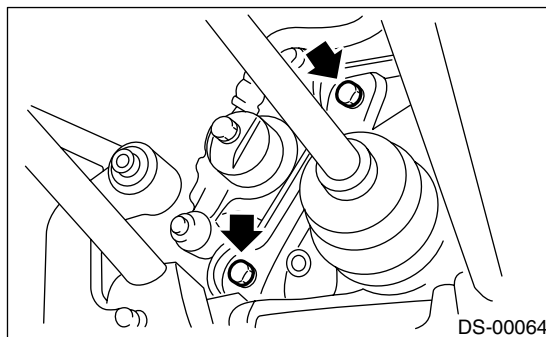

- 7) Remove the disc rotor from hub.

NOTE:

If the disc rotor seizes up within hub, drive it out by installing an 8-mm bolt into bolt hole in disc rotor.

- 8) Disconnect the parking brake cable end.

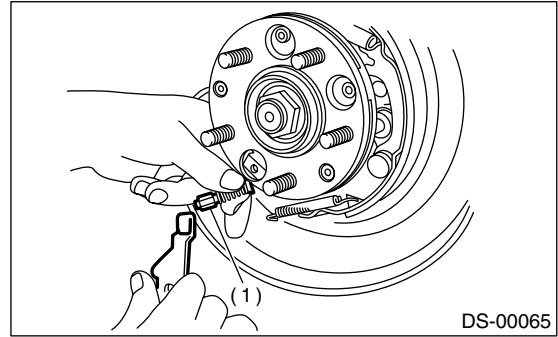

- (1) Cable end

- 9) Disconnect the rear stabilizer from rear lateral link.

- 10) Remove the bolts which secure the trailing link assembly to rear housing.

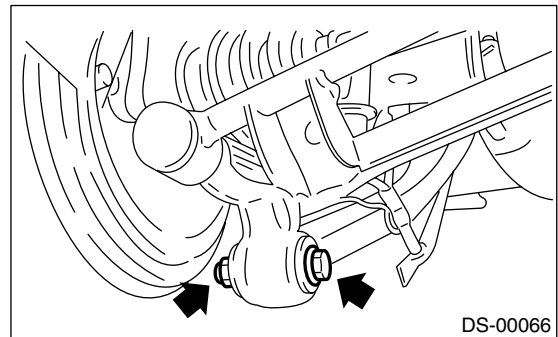

- 11) Remove the bolts which secure the lateral assembly to rear housing.

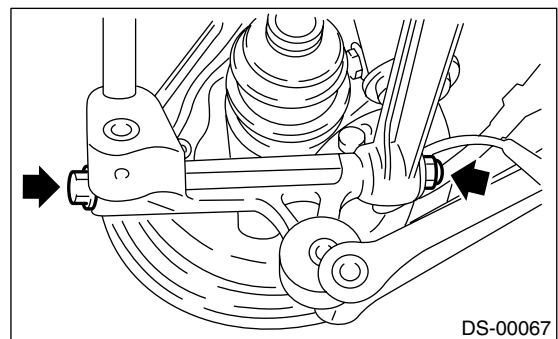

REAR AXLE

DRIVE SHAFT SYSTEM

12) Remove the rear ABS wheel speed sensor from back plate.

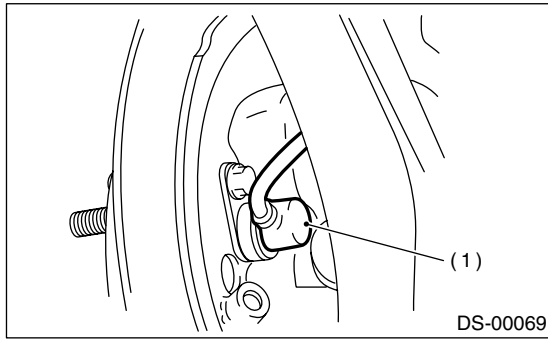

(1) ABS wheel speed sensor

13) Disengage the BJ from housing splines, and then remove the rear drive shaft assembly. If it is hard to remove, use the STs.

ST1 926470000 AXLE SHAFT PULLER
ST2 927140000 AXLE SHAFT PULLER PLATE

NOTE:

- Be careful not to damage the oil seal lip when removing the rear drive shaft.
- When the rear drive shaft is to be replaced, also replace the inner oil seal with a new one.

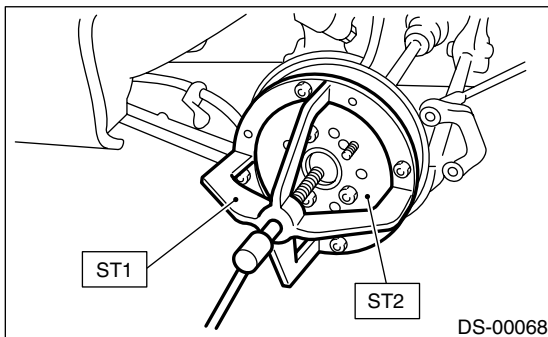

14) Remove the bolts which secure the rear housing to strut, and separate the two.

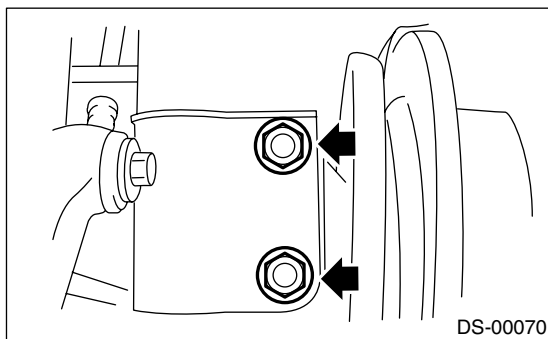

B: INSTALLATION

- 1) Temporarily tighten the rear axle to strut.
- 2) Insert the rear drive shaft into rear axle.

NOTE:

Be careful not to damage the inner oil seal lip.

- 3) Temporarily tighten the axle nut.
- 4) Using a new self-locking nut, temporarily tighten the rear housing assembly and lateral link assembly.

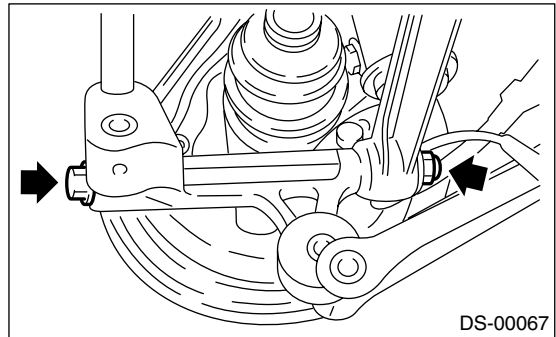

- 5) Using a new self-locking nut, temporarily tighten the rear housing assembly and trailing link assembly.

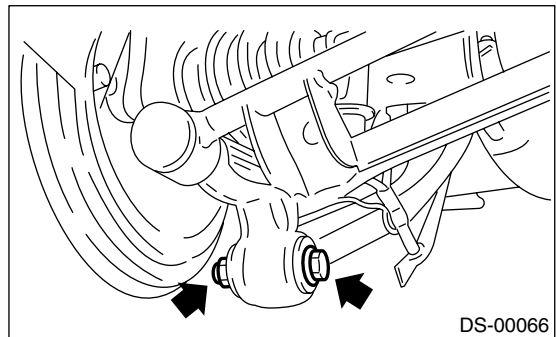

- 6) Tighten the rear housing assembly and strut assembly using a new self-locking nut.

Tightening torque:

200 N·m (20.4 kgf-m, 148 ft-lb)

- 7) Using a new self-locking nut, install the rear stabilizer and rear lateral link.

Tightening torque:

44 N·m (4.5 kgf-m, 32.5 ft-lb)

- 8) Connect the parking brake cable to parking brake.
- 9) Install the disc rotor on rear housing assembly.

10) Install the disc brake caliper on back plate.

Tightening torque:

Except STi model

52 N·m (5.3 kgf·m, 38.3 ft·lb)

STi model

65 N·m (6.6 kgf·m, 47.9 ft·lb)

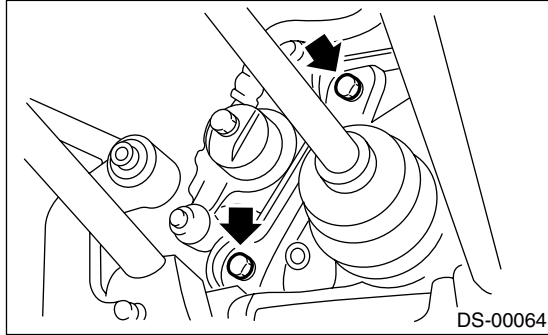

11) Adjust the parking brake lever stroke by turning the adjuster.

12) While applying the parking brake, tighten a new axle nut using a socket wrench. Lock the axle nut after tightening.

Tightening torque:

190 N·m (19.4 kgf·m, 140 ft·lb)

CAUTION:

Do not overtighten it as this may damage the wheel bearing.

13) Install rear ABS wheel speed sensor.

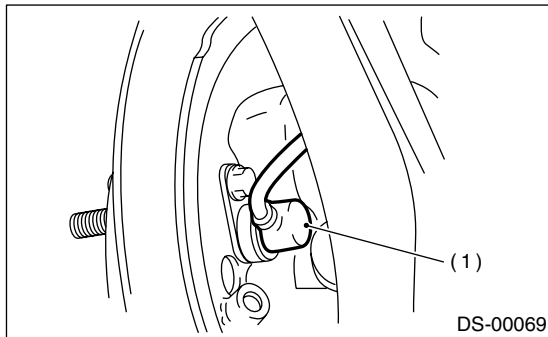

(1) ABS wheel speed sensor

14) Install the wheel and tighten the wheel nuts to specified torque.

Tightening torque:

90 N·m (9.2 kgf·m, 66 ft·lb)

15) Make the tires contact the ground fully.

CAUTION:

Make the tires contact the ground fully and the vehicle be in curb weight whenever carrying out the tightening of bush portions.

16) Tighten the installation bolt of rear housing assembly and lateral link assembly.

Tightening torque:

140 N·m (14.3 kgf·m, 103 ft·lb)

17) Tighten the installation bolt of rear housing assembly and trailing link assembly.

Tightening torque:

90 N·m (9.2 kgf·m, 66 ft·lb)

C: DISASSEMBLY

1) Using the ST1 and ST2, remove the hub from rear housing.

ST1 927080000 HUB STAND

ST2 927420000 HUB REMOVER

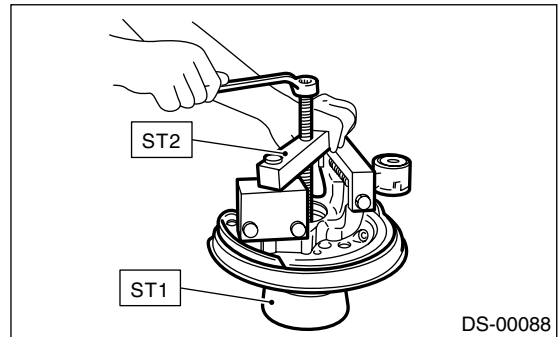

2) Remove the back plate from rear housing.

3) Using a standard screwdriver, remove the outer and inner oil seals.

4) Using a flat tip screwdriver, remove the snap ring.

NOTE:

Be careful not to damage the housing at removal.

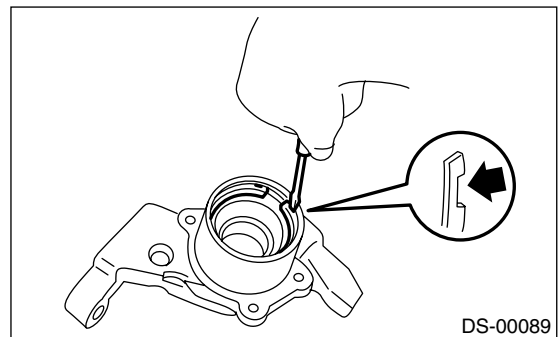

REAR AXLE

DRIVE SHAFT SYSTEM

5) Using the ST1 and ST2, remove the bearing by pressing the inner race.

ST1 927430000 HOUSING STAND

ST2 927440000 BEARING REMOVER

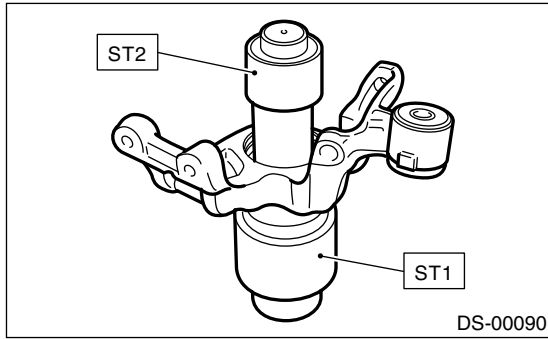

6) Remove the tone wheel bolts, and then remove the tone wheel from hub.

7) Using the ST, press the hub bolt out.

ST 927080000 HUB STAND

CAUTION:

Be careful not to hammer the hub bolts. This may deform the hub.

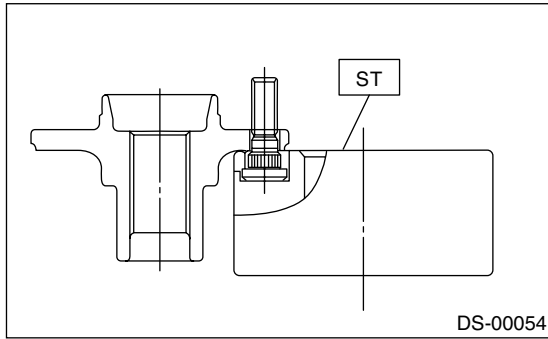

D: ASSEMBLY

NOTE:

When the hub is to be removed from housing, replace the bearing set and oil seal with new ones.

1) Using the ST, press the new hub bolt into place.

NOTE:

- Ensure the hub bolt closely contacts the hub.
- Use a 12 mm (0.47 in) hole in the ST to prevent the hub bolt from tilting during installation.

ST 927080000

HUB STAND

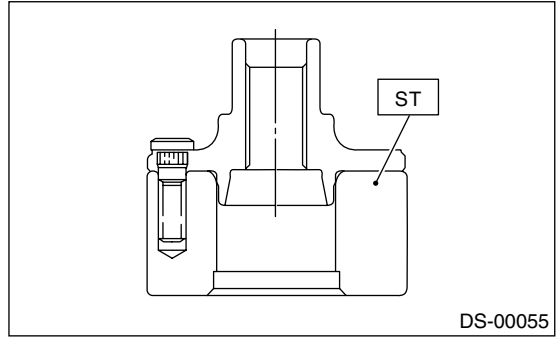

2) Remove foreign particles (dust, rust, etc.) from mating surfaces of the hub tone wheel, and then install the tone wheel to hub.

NOTE:

- Ensure the tone wheel closely contacts the hub.
- Be careful not to damage the tone wheel teeth.

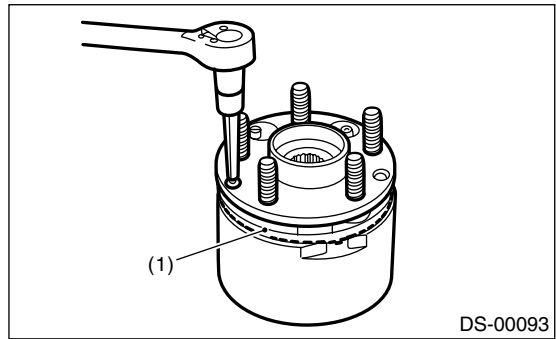

(1) Tone wheel

3) Clean the housing interior completely. Using the ST1 and ST2, press the bearing into housing.

ST1 927430000 HOUSING STAND

ST2 927440000 BEARING REMOVER

NOTE:

Be careful not to remove the plastic lock from inner race when installing the bearing.

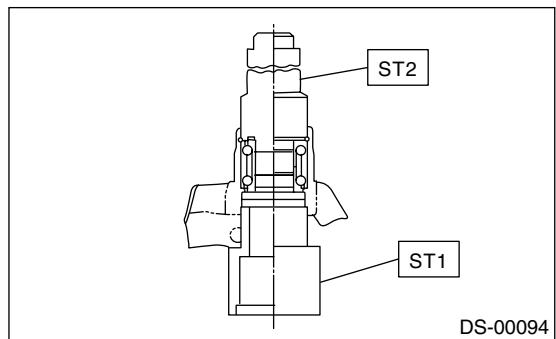

4) Using pliers, install the snap ring firmly.

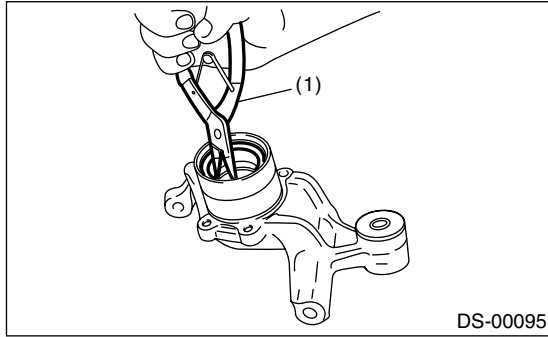

(1) Pliers

5) Using the ST1 and ST2, press the outer oil seal until it comes in contact with snap ring.

ST1 927430000 HOUSING STAND
ST2 927460000 OIL SEAL INSTALLER

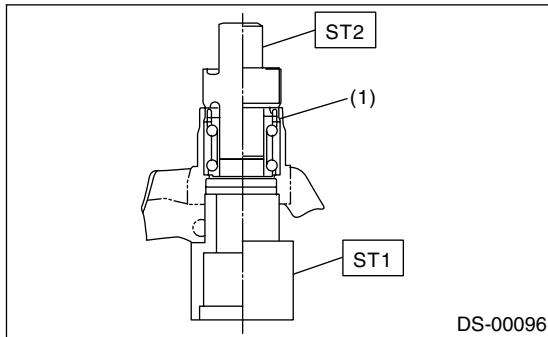

(1) Snap ring

6) Invert both ST1 and housing.

7) Using the ST2, press the inner oil seal into housing until it touches the bottom.

ST1 927430000 HOUSING STAND
ST2 927460000 OIL SEAL INSTALLER

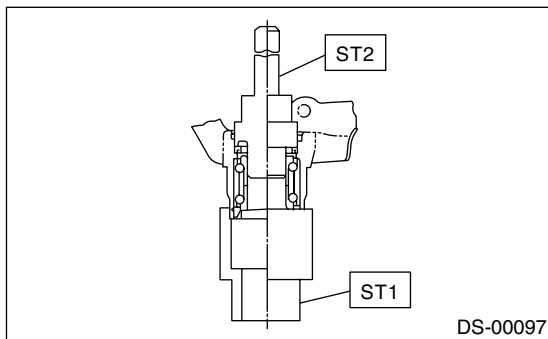

8) Using the ST1 and ST2, press the sub seal into place.

ST1 927430000 HOUSING STAND
ST2 927460000 OIL SEAL INSTALLER

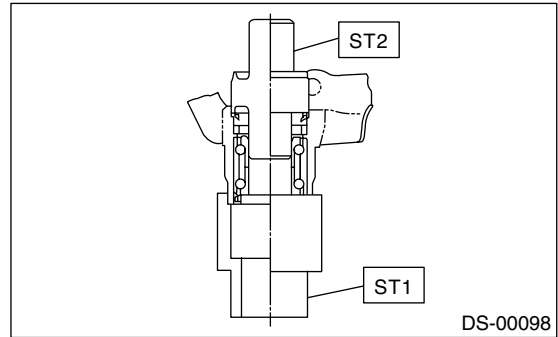

9) Apply sufficient grease to oil seal lip.

Specified grease:
SHELL 6459N

NOTE:

- If specified grease is not available, remove the bearing grease and apply Auto Rex A instead.
- Do not mix different types of grease.

10) Install the back plate to rear housing.

Tightening torque:
52 N·m (5.3 kgf-m, 38.3 ft-lb)

11) Using the ST1 and ST2, press the bearing into hub.

ST1 927080000 HUB STAND
ST2 927450000 HUB INSTALLER

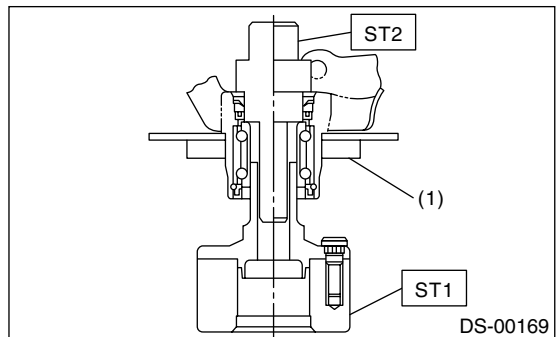

(1) Back plate

E: INSPECTION

1) Moving the front tire up and down by hand, check there is no backlash in bearing, and check the wheel rotates smoothly.

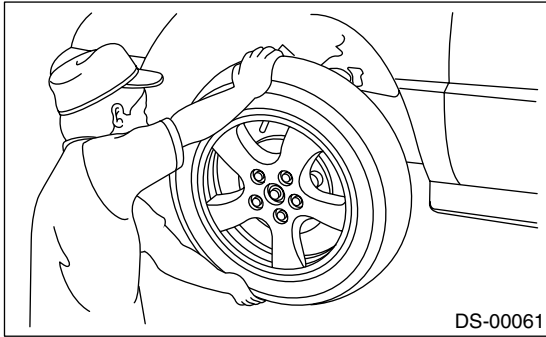

2) Inspect the lean of axis direction using a dial gauge. Replace the hub bearing if the load range exceeds the limitation.

Limit:

Maximum: 0.05mm (0.0020 in)

