

CONTROL MODULE I/O SIGNAL

ABS (DIAGNOSTICS)

5. Control Module I/O Signal

A: ELECTRICAL SPECIFICATION

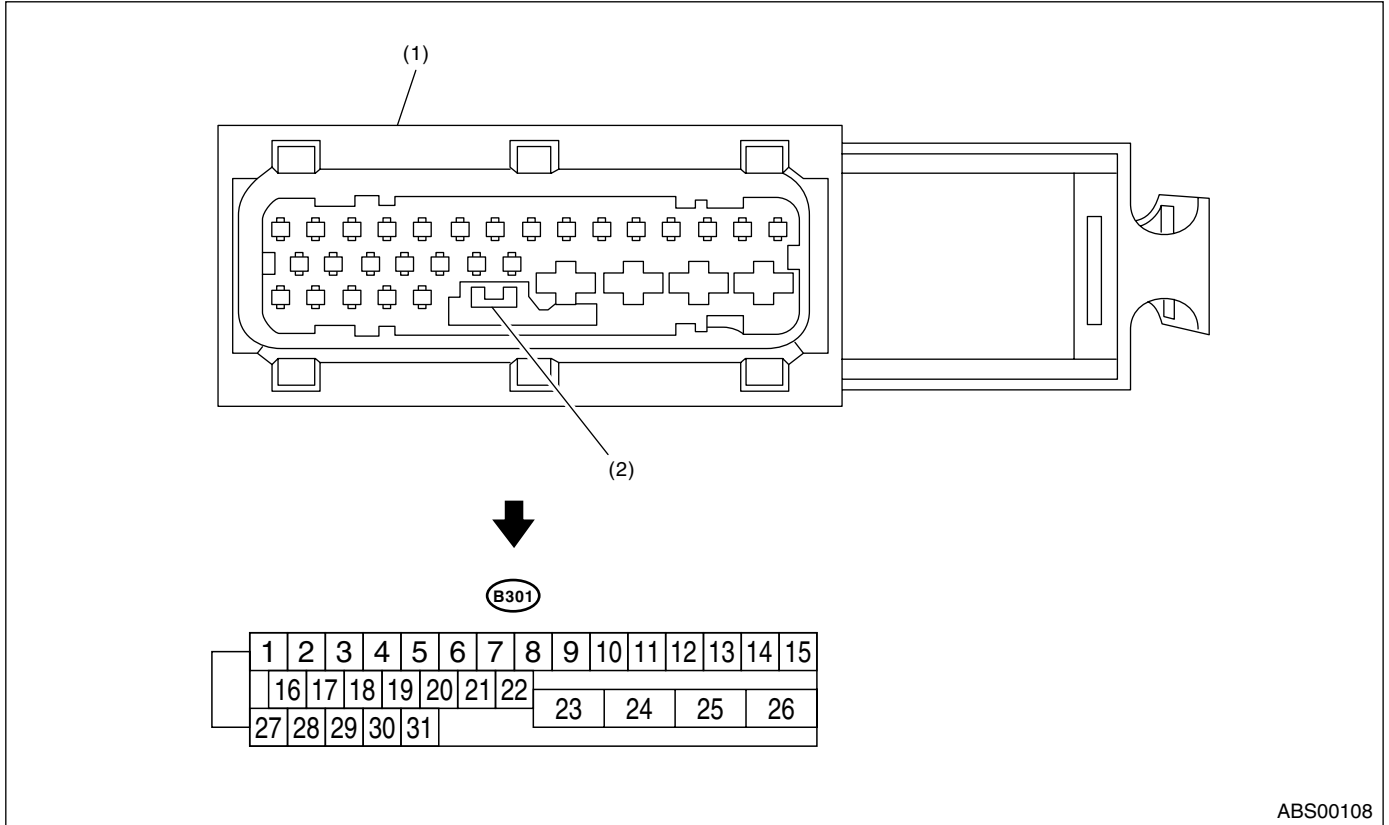

ABS00108

- (1) ABS control module and hydraulic control unit (ABSCM&H/U) connector (2) Connector switch

NOTE:

- The terminal numbers in ABS control module and hydraulic control unit connector are as shown in the figure.
- When the connector is removed from ABSCM&H/U, the connector switch closes the circuit between terminal No. 22 and No. 23. The ABS warning light illuminates.

CONTROL MODULE I/O SIGNAL

ABS (DIAGNOSTICS)

Contents		Terminal No. (+) — (-)	Input/Output signal
			Measured value and measuring conditions
ABS wheel speed sensor*2 (Wheel speed sensor)	Front left wheel	9 — 10	0.12 — 1 V (When it is 20 Hz.)
	Front right wheel	11 — 12	
	Rear left wheel	7 — 8	
	Rear right wheel	14 — 15	
Valve relay power supply*1		24 — 23	10 — 15 V
Motor relay power supply*1		25 — 23	10 — 15 V
G sensor*2	Power supply	30 — 28	4.75 — 5.25 V
	Ground	28	—
	Output	6 — 28	2.1 — 2.5 V when vehicle is in horizontal position.
Lateral G sensor (STi model)	Power supply	30 — 28	4.75 — 5.25 V
	Ground	28	—
	Output	29 — 28	2.3 — 2.7 V when vehicle is in horizontal position.
Stop light switch*1		2 — 23	Less than 1.5 V when the stop light is OFF and, 10 — 15 V when the stop light is ON.
ABS warning light*2		22 — 23	Less than 1.5 V within 1.5 seconds immediately after ignition switch has been turned to ON, and 10 — 15 V after 1.5 seconds has elapsed.
Brake warning light*2 (EBD warning light)		21 — 23	Less than 1.5 V within 1.5 seconds immediately after ignition switch has been turned to ON, and 10 — 15 V after 1.5 seconds has elapsed.
AT ABS signal (AT models only)		31 — 23	Less than 1.5 V when the ABS control still operates and more than 5.5 V when ABS does not operate.
ABS operation signal monitor		3 — 23	Less than 1.5 V when the ABS control still operates and more than 5.5 V when ABS does not operate.
Subaru Select Monitor*2	Data is received.	20 — 23	Less than 1.5 V when no data is received.
	Data is sent.	5 — 23	4.75 — 5.25 V when no data is sent.
ABS diagnosis connector	Terminal No. 3	29 — 23	10 — 15 V when ignition switch is ON.
	Terminal No. 6	4 — 23	10 — 15 V when ignition switch is ON.
Power supply*1		1 — 23	10 — 15 V when ignition switch is ON.
Grounding line		23	—
Grounding line		26	—

*1: Measure the I/O signal voltage after removing the connector from the ABSCM&H/U terminal.

*2: Measure the I/O signal voltage at connector (F2).

CONTROL MODULE I/O SIGNAL

ABS (DIAGNOSTICS)

B: SCHEMATIC

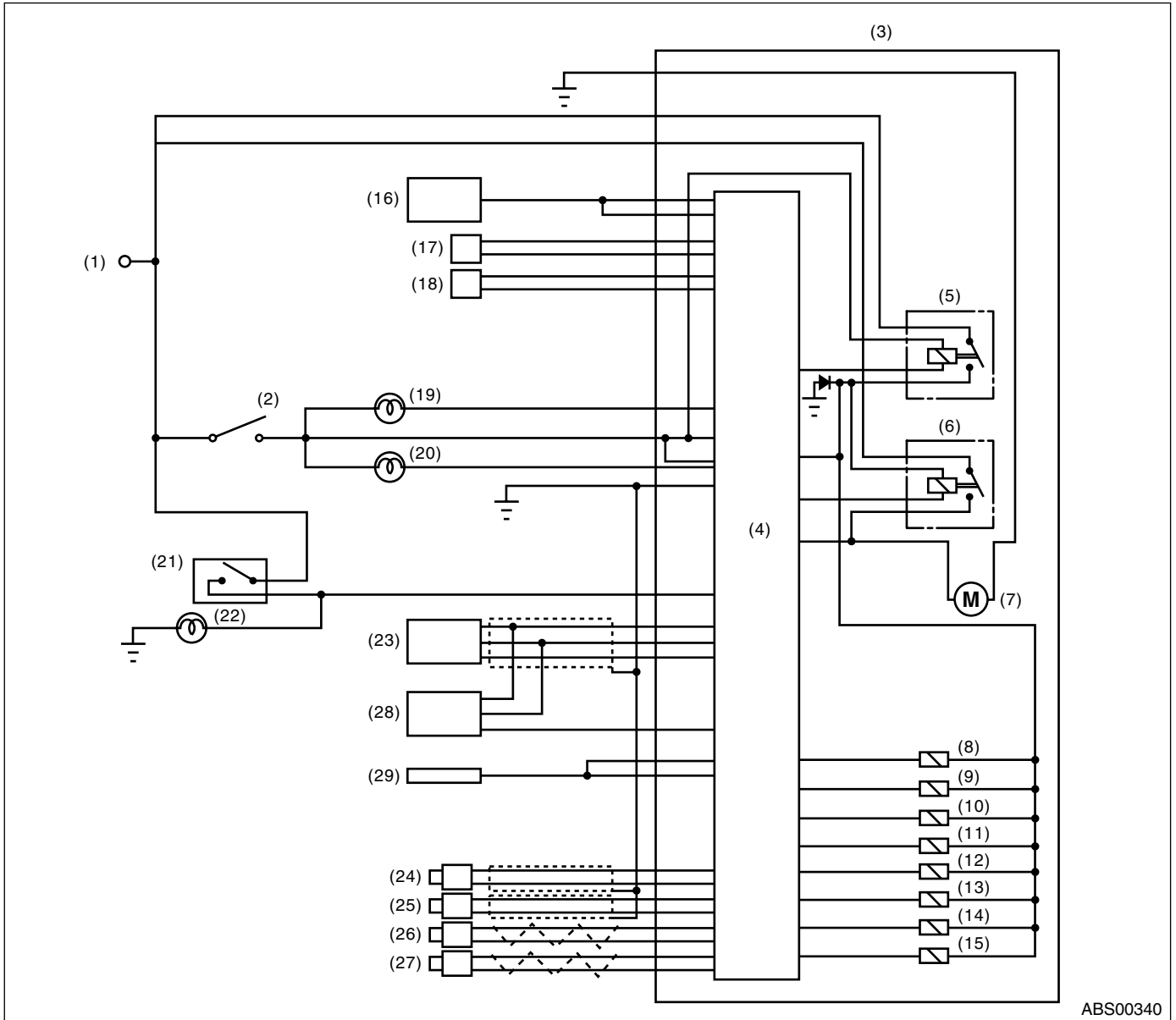

ABS00340

- | | | |
|---|---|--|
| (1) Battery | (12) Rear inlet solenoid valve LH | (23) G sensor |
| (2) IGN | (13) Rear outlet solenoid valve LH | (24) Front ABS wheel speed sensor LH |
| (3) ABS control module and hydraulic control unit (ABSCM&H/U) | (14) Rear inlet solenoid valve RH | (25) Front ABS wheel speed sensor RH |
| (4) ABS control module area | (15) Rear outlet solenoid valve RH | (26) Rear ABS wheel speed sensor LH |
| (5) Valve relay | (16) Transmission control module (TCM) (AT model) | (27) Rear ABS wheel speed sensor RH |
| (6) Motor relay | (17) Diagnosis connector | (28) Lateral G sensor (STi model) |
| (7) Motor | (18) Data link connector | (29) Driver's control center differential control module (STi model) |
| (8) Front inlet solenoid valve LH | (19) Brake warning light | |
| (9) Front outlet solenoid valve LH | (20) ABS warning light | |
| (10) Front inlet solenoid valve RH | (21) Stop light switch | |
| (11) Front outlet solenoid valve RH | (22) Stop light | |

C: WAVEFORM

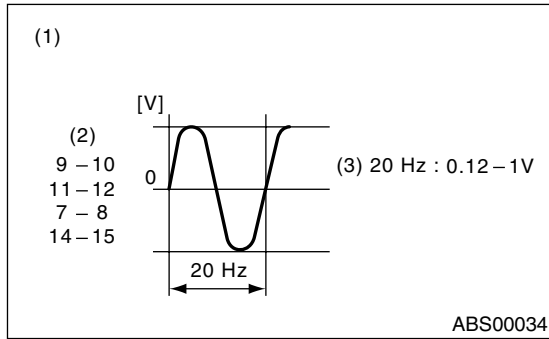

- (1) ABS wheel speed sensor
- (2) Terminal No.
- (3) Standard output voltage