

COOLING SYSTEM

HVAC SYSTEM (HEATER, VENTILATOR AND A/C)

2. Cooling System

A: COMPRESSOR

The rotary type compressor consists of an integrally formed rotor and shaft, five vanes, and a cylinder.

As the rotor turns, the vanes that are movably fitted in the rotor slide over the wall of the oval-shaped cylinder while drawing, compressing, and discharging refrigerant gas.

The compressor shell has an oil separator at its rear end. High-pressure refrigerant gas having entered this chamber is separated from the oil it contains before flowing out through the compressor's delivery port.

There is a check valve in the front housing to avoid reverse rotation of the compressor which would otherwise occur when the compressor is stopped.

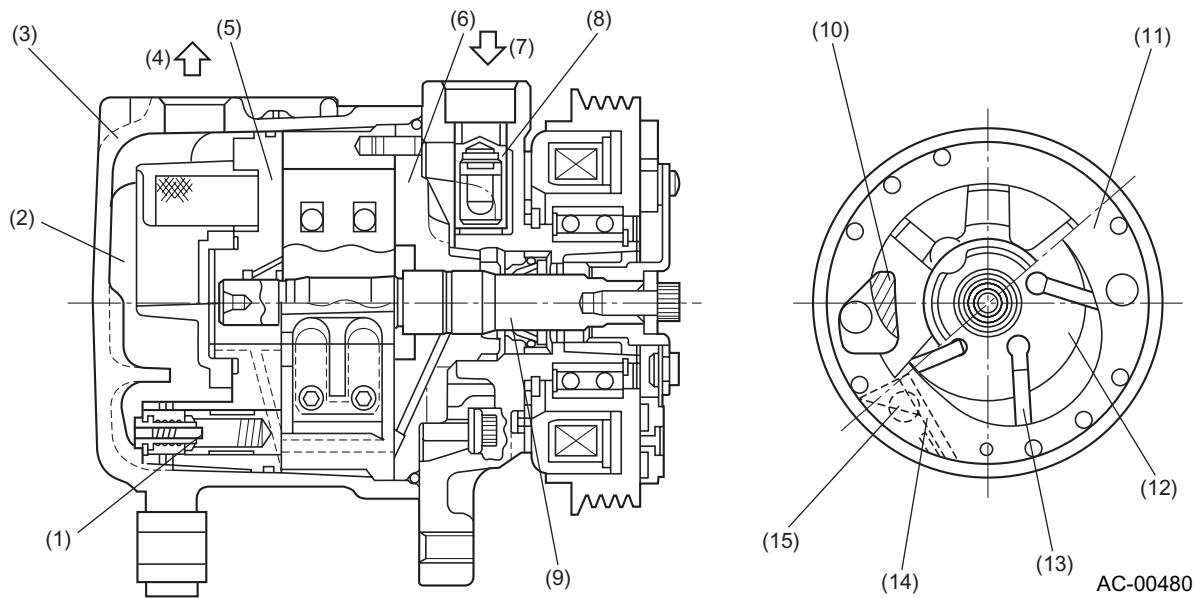

- | | |
|---------------------------|----------------------|
| (1) Oil cut-off valve | (9) Shaft |
| (2) Oil separator chamber | (10) Suction port |
| (3) Shell | (11) Cylinder |
| (4) Discharge port | (12) Rotor |
| (5) Rear side plate | (13) Vane |
| (6) Front side plate | (14) Discharge valve |
| (7) Suction port | (15) Discharge port |
| (8) Check valve | |

AC-12

COOLING SYSTEM

HVAC SYSTEM (HEATER, VENTILATOR AND A/C)

1. PRESSURE RELIEF VALVE

This valve opens if the pressure of the high-pressure refrigerant gas rises to a dangerously high level to release part of refrigerant into the atmosphere, thus protecting the compressor. The valve is designed to limit the amount of released gas to the necessary minimum.

Valve opening pressure: 3.72 MPa (38 kgf/cm²)

Valve closing pressure: 1.8 MPa (17.5 kgf/cm²)

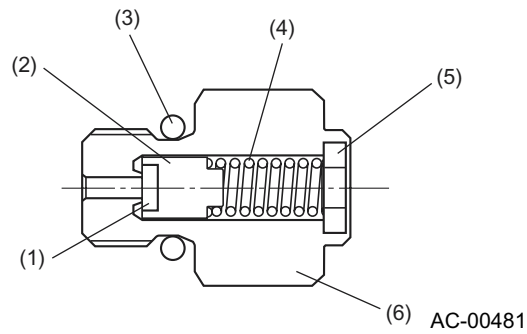

- | | |
|-----------------|------------|
| (1) Seat rubber | (4) Spring |
| (2) Seat cover | (5) Cap |
| (3) O-ring | (6) Body |

Operating characteristics

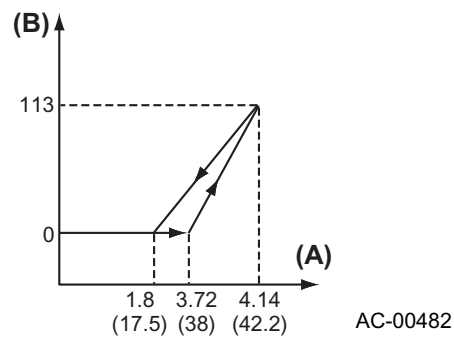

- (A) Pressure MPa (kgf/cm²)
 (B) Leakage liters/min

AC-13

COOLING SYSTEM

HVAC SYSTEM (HEATER, VENTILATOR AND A/C)

B: COOLING UNIT

The heater unit and cooling unit are integrated into a single heater and cooling unit.

The cooling section components of this unit include an evaporator, expansion valve, and case.

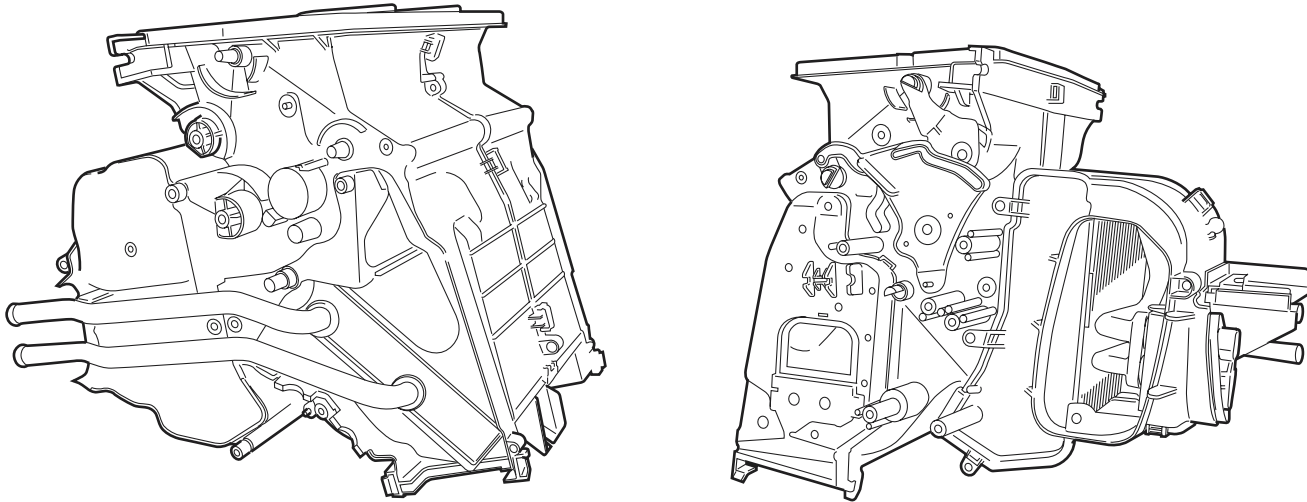

AC-00483

1. EVAPORATOR

The evaporator is a laminated type.

When a low-pressure, low-temperature refrigerant is sprayed by the expansion valve into the evaporator, it evaporates and cools the evaporator surfaces.

The cabin air is drawn by the blower and cooled down as it flows over the evaporator. The cooled air then flows passing through the heater unit and delivered into the cabin through vent outlets.

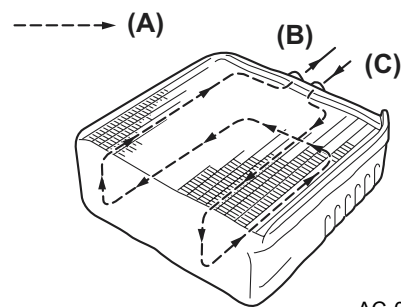

AC-00484

- (A) Refrigerant flow
- (B) Outlet
- (C) Inlet

AC-14

COOLING SYSTEM

HVAC SYSTEM (HEATER, VENTILATOR AND A/C)

2. EXPANSION VALVE

The expansion valve regulates the flow of refrigerant such that heat exchange takes place optimally. The expansion valve performs two functions; it sprays the high-pressure refrigerant from the condenser using a throttle valve, and it regulates the amount of the spray by changing opening of the throttle valve.

The expansion valve consists of such main components as a heat sensing cylinder, diaphragm, ball valve, spring, and adjusting screw.

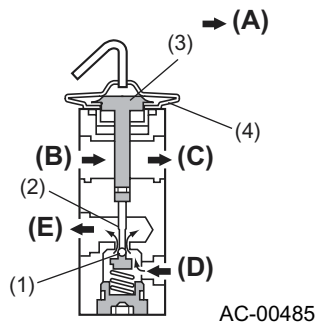

- | | |
|---------------------------|---|
| (1) Ball valve | (A) Refrigerant flow |
| (2) Shaft | (B) From evaporator (low-pressure side) |
| (3) Heat sensing cylinder | (C) To compressor |
| (4) Diaphragm | (D) To liquid tank |
| | (E) To evaporator (high-pressure side) |

The heat (temperature) sensing cylinder is held in contact with the evaporator outlet pipe so that a pressure corresponding to the sensed temperature may be applied to the chamber above the diaphragm. There is a pressure equalizing hole which communicates with the chamber below the diaphragm to transmit changes in the refrigerant pressure to the chamber. The ball valve is linked with the diaphragm and moves according to changes in the balance between the force applied to the diaphragm and the tension of the spring.

AC-15

COOLING SYSTEM

HVAC SYSTEM (HEATER, VENTILATOR AND A/C)

C: CONDENSER

The condenser used in the Impreza's air conditioning system is the newly developed "subcooling condenser" that integrates a multi-flow type condenser and a modulator (gas-liquid separator) into a single unit. The condenser has a high heat-exchange efficiency.

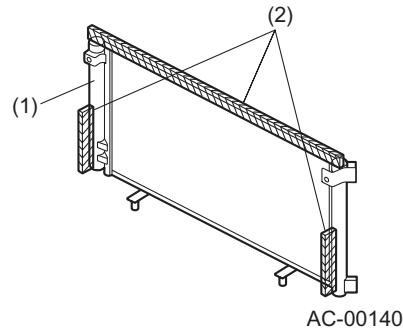

- (1) Liquid tank
- (2) Gasket

1. SUBCOOLING CONDENSER

The new subcooling condenser has a subcooling section where part of the refrigerant that remains in gas form is cooled and reduced into liquid form. This enables almost 100% of the refrigerant to be re-liquefied.

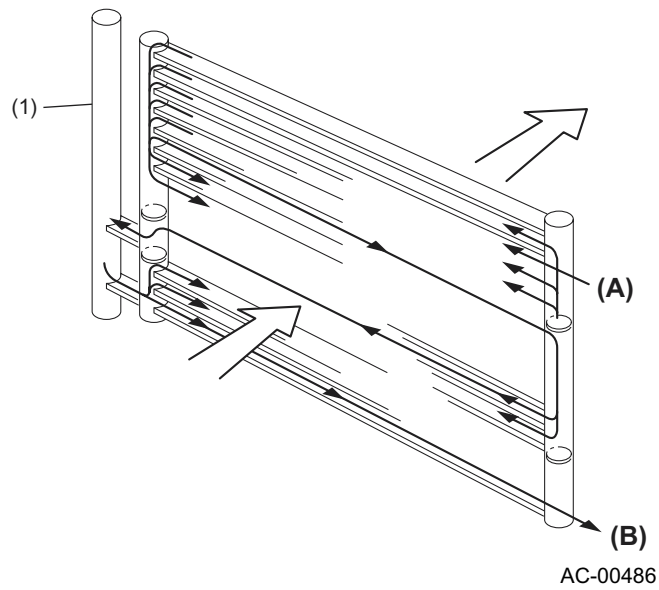

- (1) Liquid tank

- (A) Suction
- (B) Discharge

AC-16

COOLING SYSTEM

HVAC SYSTEM (HEATER, VENTILATOR AND A/C)

D: PRESSURE SWITCH

The pressure switch is a high-pressure side component of the refrigeration cycle (cooling cycle). It consists of a diaphragm that receives refrigerant gas pressure, a snap plate, a rod, and contacts that open both when the gas pressure is too low and when it is too high.

The pressure switch plays the following roles:

- Prevents “no-gas” operation due to leakage (when gas pressure is too low)
- Protects the system against abnormally high refrigerant pressure (when gas pressure is too high)

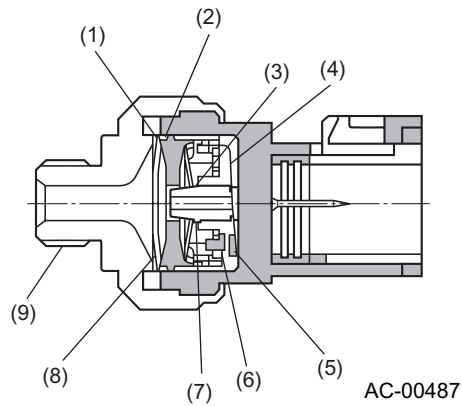

- | | |
|--------------------------------|-------------------------------|
| (1) Snap plate (high pressure) | (6) Contact |
| (2) Disc | (7) Snap plate (low pressure) |
| (3) Rod | (8) Diaphragm |
| (4) Leaf spring | (9) Housing |
| (5) Contact | |

ON-OFF pressures

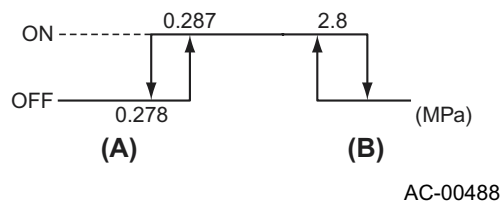

- (A) Low pressure
(B) High pressure

1. SPECIFICATIONS

Low limit pressure	OFF	Lower than 0.278 MPa (2.8 kgf/cm ²)
Normal pressure	Normal pressure	Between 0.287 and 2.8 MPa (2.8 and 28 kgf/cm ²)
High limit pressure	OFF	Higher than 2.8 MPa (28 kgf/cm ²)

AC-17