

# **EXTERIOR/INTERIOR TRIM**

# General Description

EXTERIOR/INTERIOR TRIM

## 1. General Description

### A: COMPONENT

#### 1. UNDER COVER

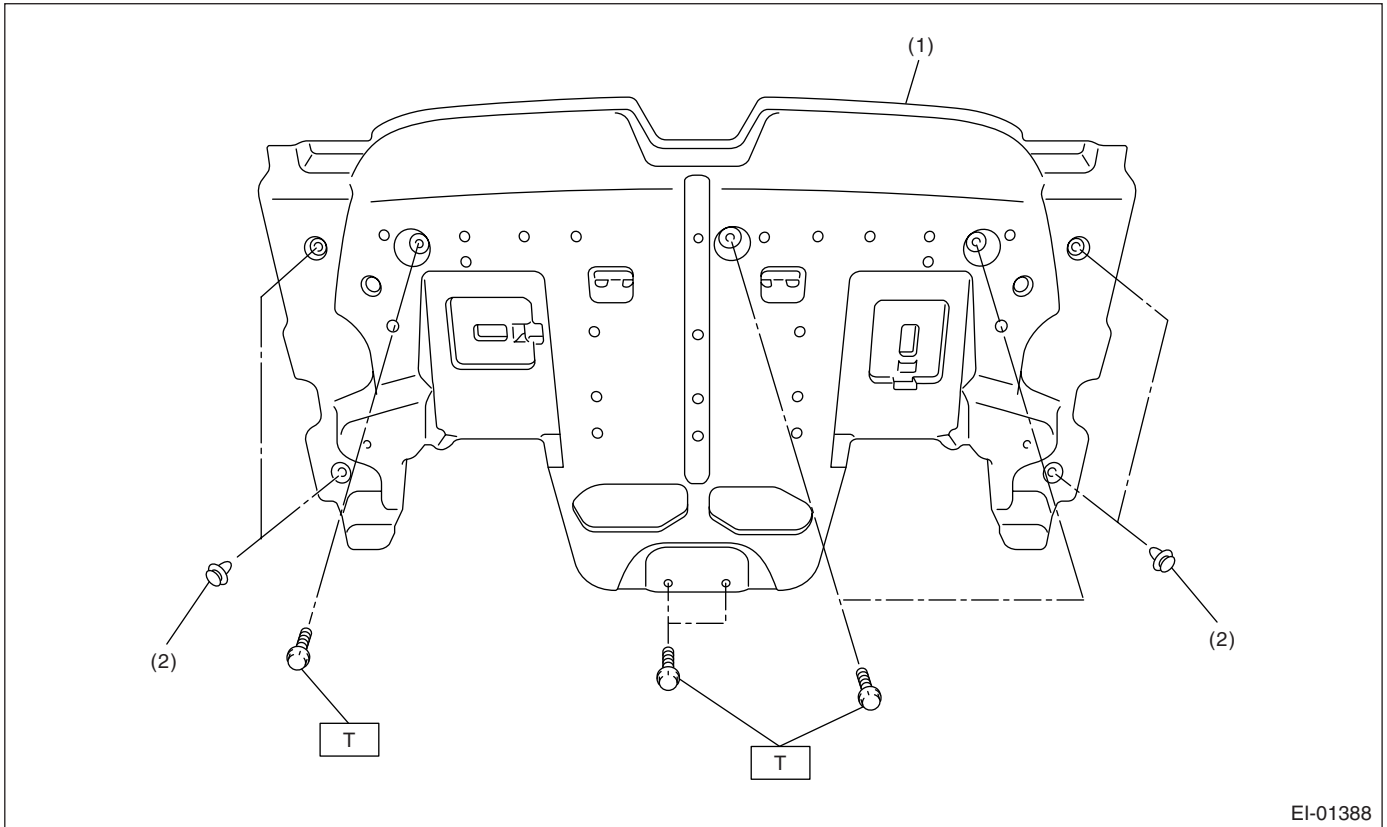

EI-01388

(1) Under cover

(2) Clip (side)

**Tightening torque: N-m (kgf-m, ft-lb)**

**T: 14 (1.4, 10.3)**

## 2. FRONT HOOD GRILLE

### • TURBO MODEL

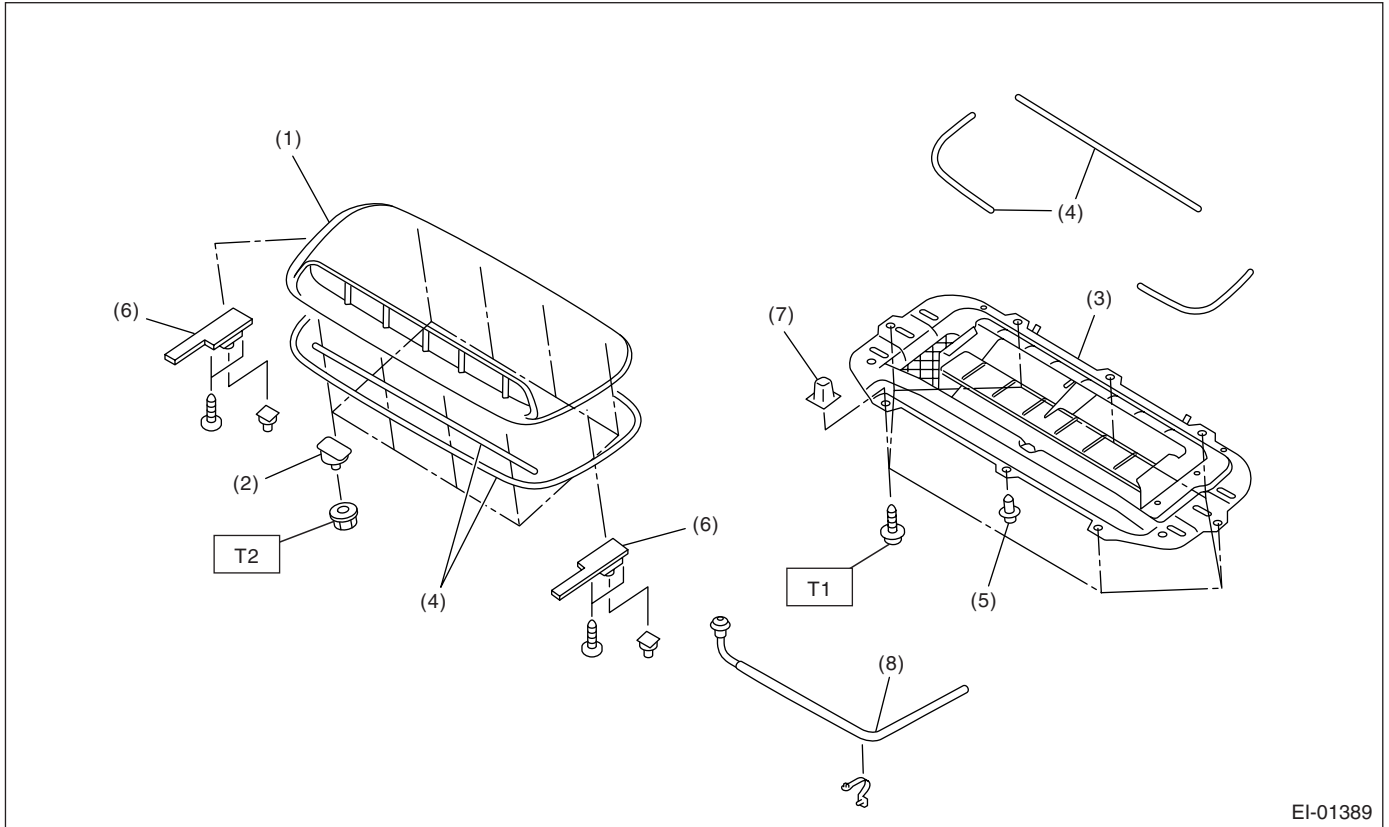

- |                       |   |
|-----------------------|---|
| (1) Front hood grille | (5) Clip                                |
| (2) Bolt              | (6) Side plate                          |
| (3) Grille duct       | (7) Grommet                             |
| (4) Packing           | (8) Intercooler water spray (STI model) |

**Tightening torque: N·m (kgf·m, ft·lb)**

**T1: 1.0 (0.1, 0.74)**

**T2: 4.5 (0.46, 3.32)**

# General Description

EXTERIOR/INTERIOR TRIM

## 3. FRONT BUMPER

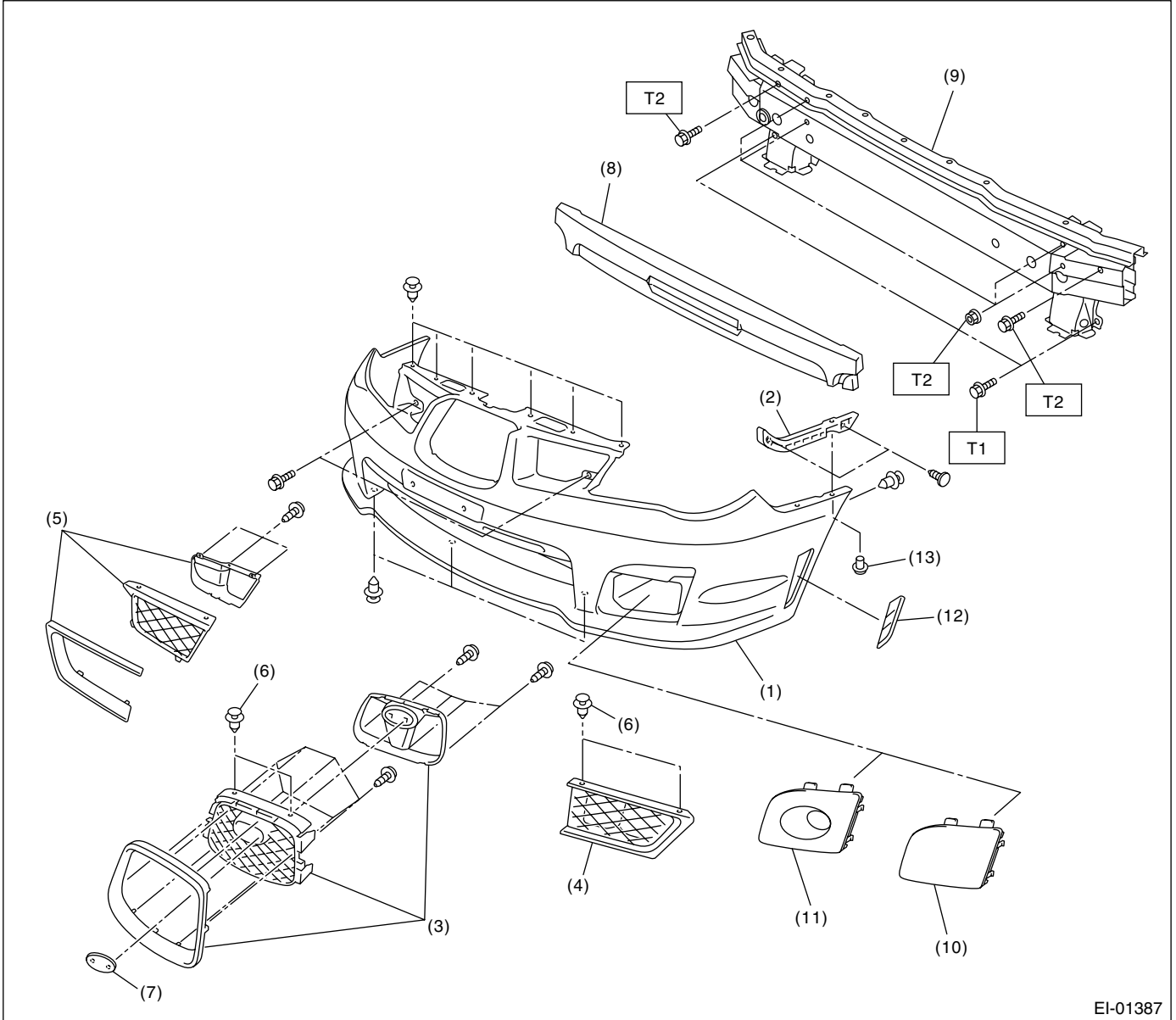

EI-01387

- |                         |                                  |
|-------------------------|----------------------------------|
| (1) Bumper face         | (7) Front grille emblem          |
| (2) Slider              | (8) Energy absorber form         |
| (3) Front grille center | (9) Bumper beam ASSY             |
| (4) Front grille LH     | (10) Fog light cover (STI model) |
| (5) Front grille RH     | (11) Fog light cover             |
| (6) Clip                | (12) Cover side (STI model)      |

- (13) Clip (Sedan model)

**Tightening torque: N·m (kgf·m, ft·lb)**

**T1: 32 (3.3, 24)**

**T2: 69 (7.0, 51)**

## 4. REAR BUMPER

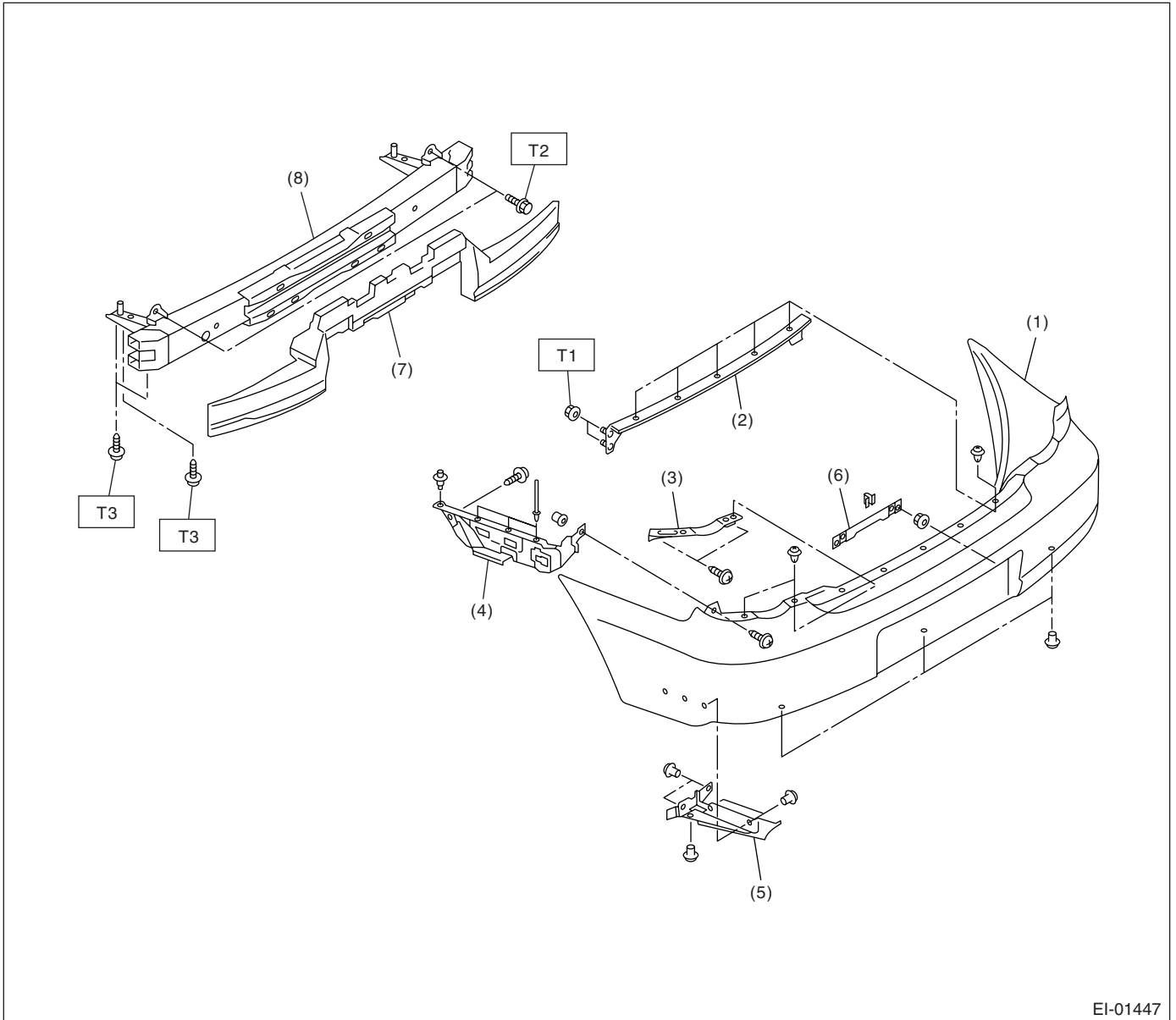

EI-01447

- |                          |                            |
|--------------------------|----------------------------|
| (1) Bumper face          | (5) Bumper side cover      |
| (2) Bumper upper beam    | (6) License plate base     |
| (3) Bumper upper bracket | (7) Bumper energy absorber |
| (4) Bumper side bracket  | (8) Bumper back beam       |

**Tightening torque: N·m (kgf·m, ft·lb)**

**T1: 33 (3.4, 24)**

**T2: 34 (3.5, 25)**

**T3: 95 (9.7, 70)**

# General Description

EXTERIOR/INTERIOR TRIM

## 5. MUD GUARD

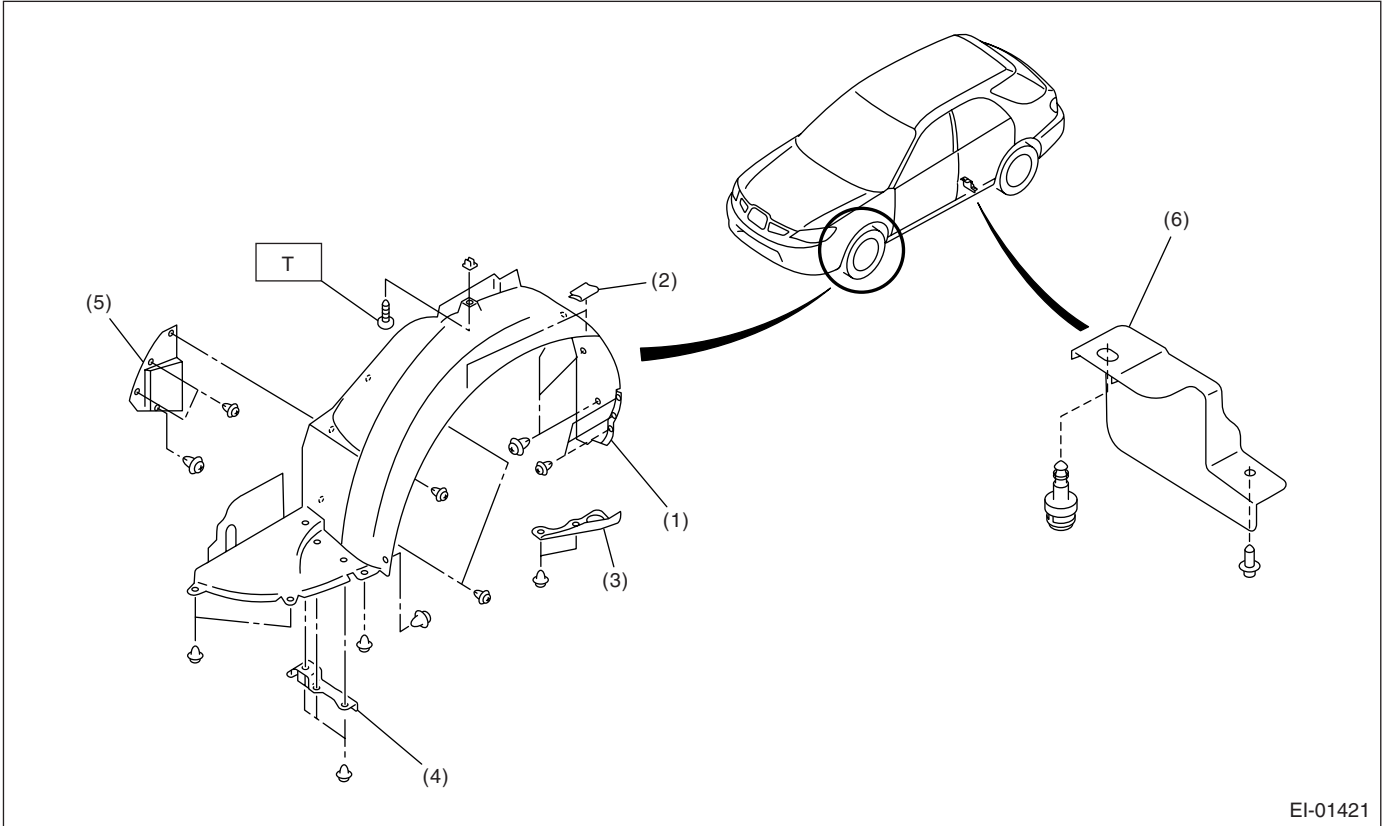

EI-01421

- |                     |                          |
|---------------------|--------------------------|
| (1) Mud guard       | (4) Front air flap plate |
| (2) Clip            | (5) Mud guard plate (RH) |
| (3) Sub frame cover | (6) Rear air flap plate  |

**Tightening torque: N-m (kgf-m, ft-lb)**

**T: 4.5 (0.46, 3.3)**

## 6. COWL PANEL

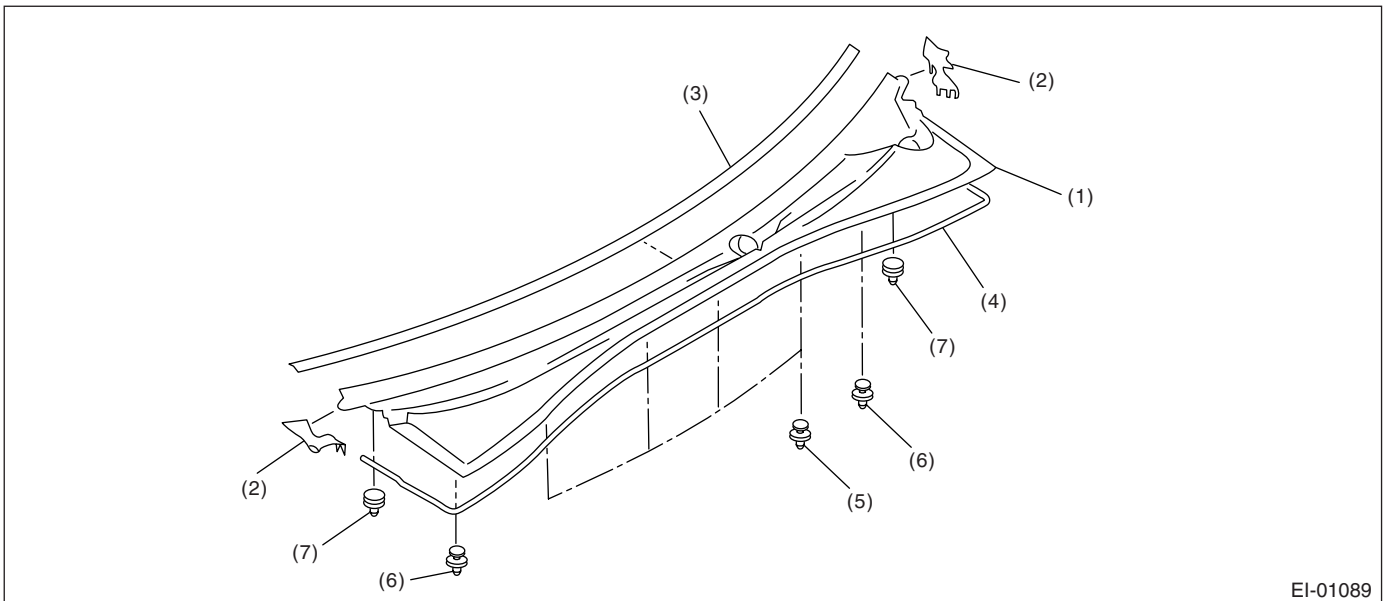

EI-01089

- |                     |                |            |
|---------------------|----------------|------------|
| (1) Cowl panel      | (4) Seal       | (7) Clip F |
| (2) Cowl side panel | (5) Clip       |            |
| (3) Protector       | (6) Clip (Pin) |            |

## 7. ROOF SPOILER

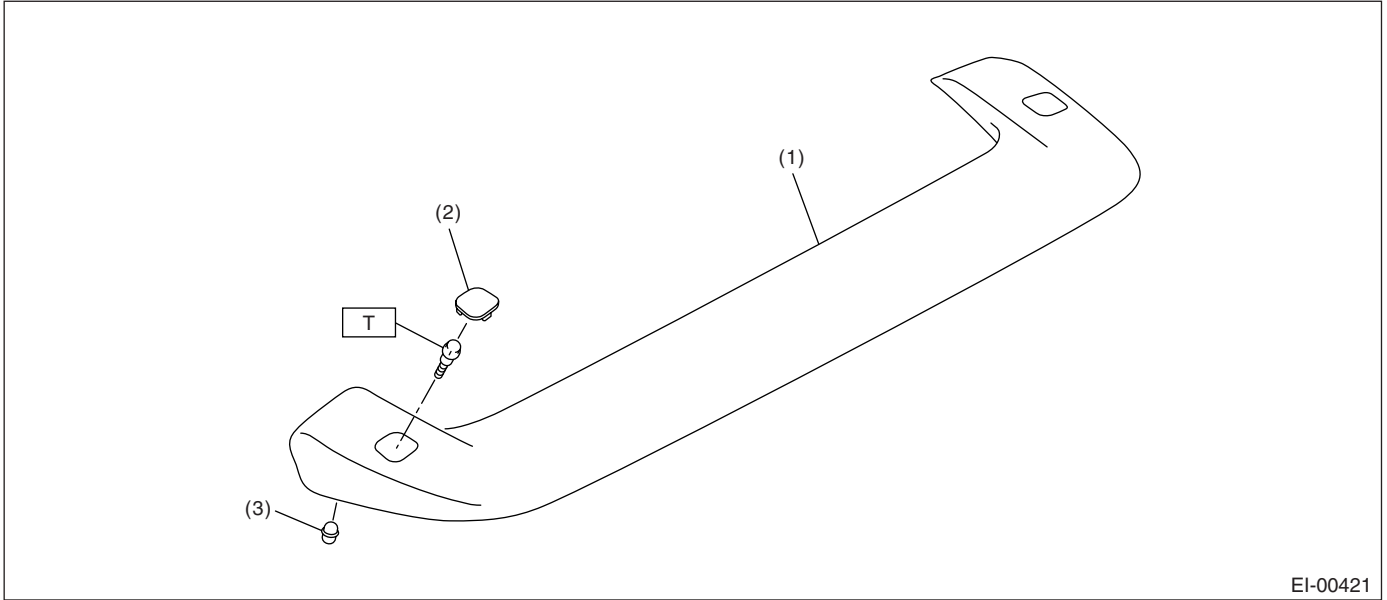

EI-00421

- (1) Roof spoiler
- (2) Cap

- (3) Clip

**Tightening torque: N·m (kgf·m, ft·lb)**  
**T: 7.5 (0.76, 5.5)**

## 8. REAR SPOILER

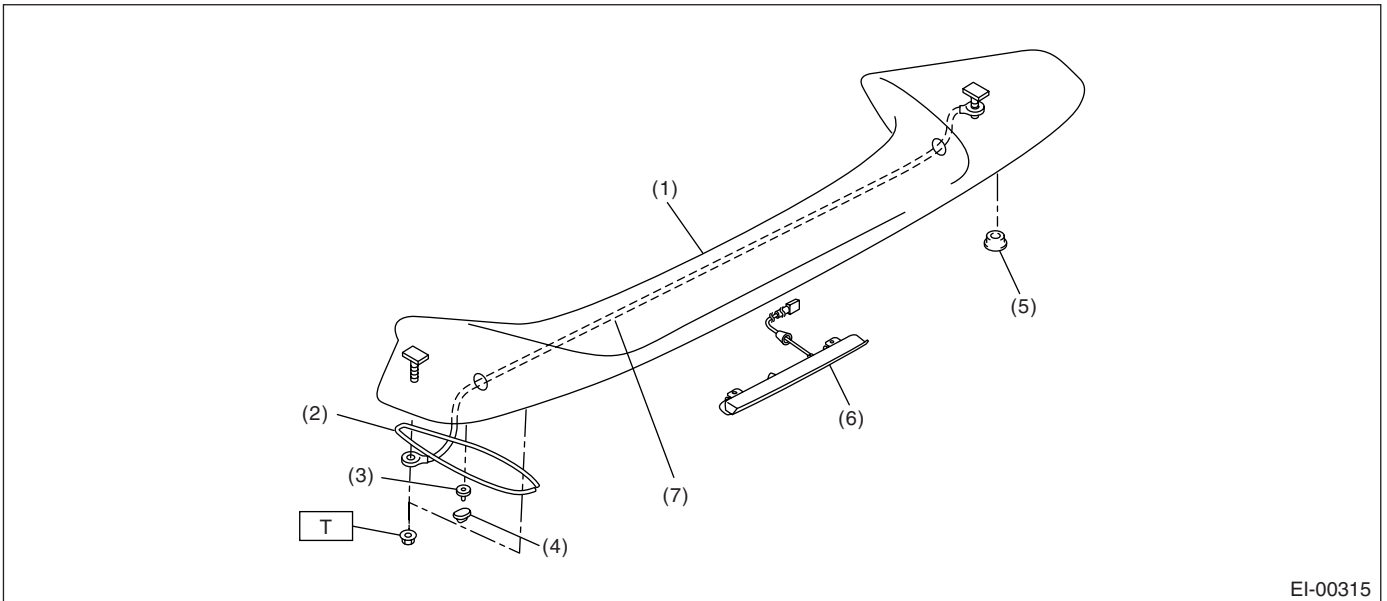

EI-00315

- (1) Rear spoiler
- (2) Protector
- (3) Clip
- (4) Grommet

- (5) Seal (RH)
- (6) High-mounted stop light
- (7) Retention cable (Inner parts)

**Tightening torque: N·m (kgf·m, ft·lb)**  
**T: 7.5 (0.76, 5.5)**

# General Description

EXTERIOR/INTERIOR TRIM

## 9. SIDE SILL SPOILER

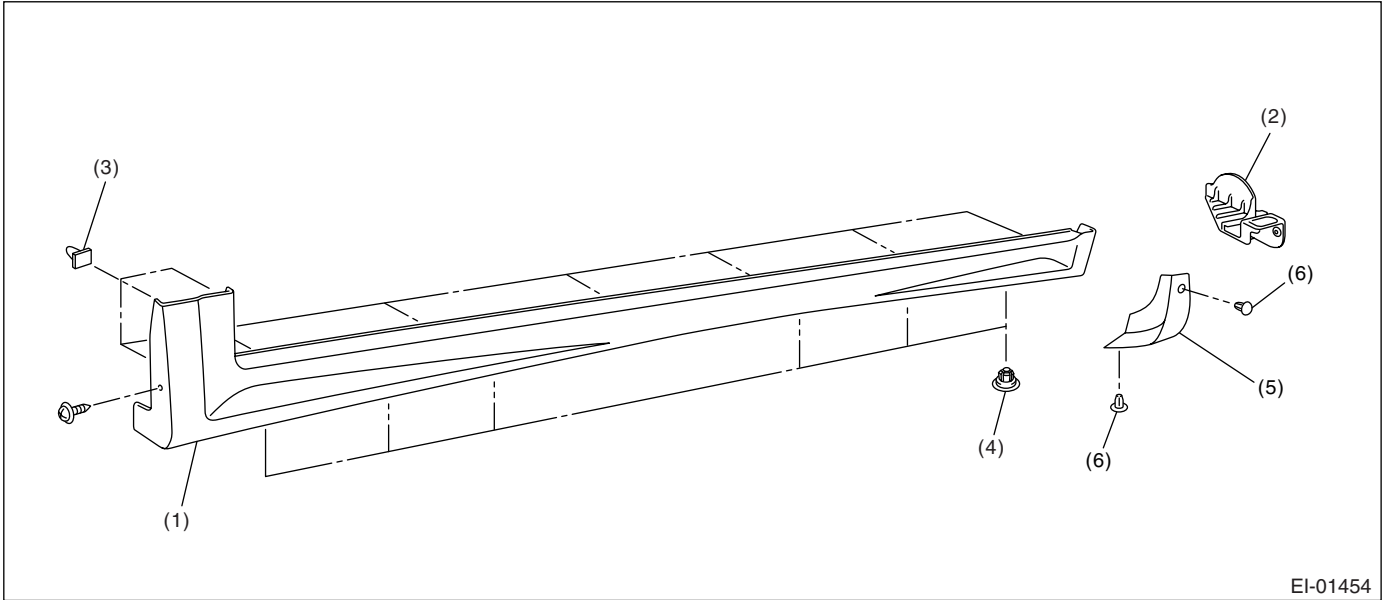

EI-01454

- (1) Side sill spoiler
- (2) Rear air flap plate

- (3) Clip
- (4) Clip (Side sill spoiler)

- (5) End cover
- (6) Clip

## 10. ROOF RAIL

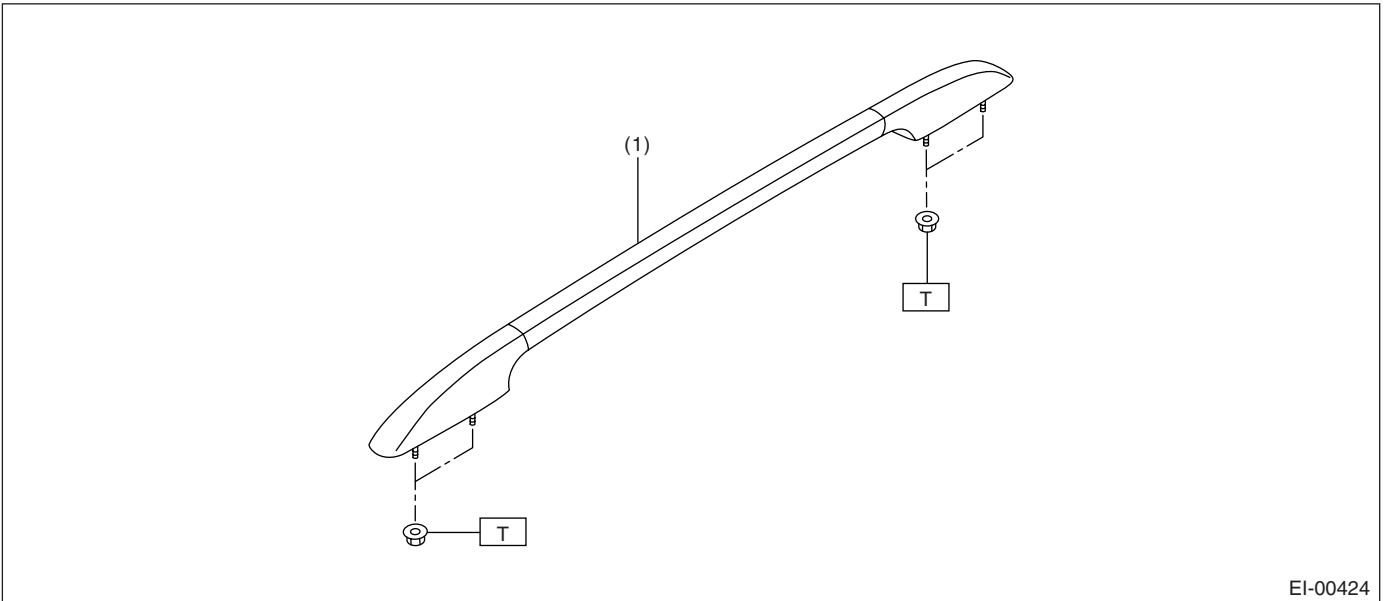

EI-00424

- (1) Roof rail

**Tightening torque: N-m (kgf-m, ft-lb)**  
**T: 7.4 (0.75, 5.46)**



## 11. ROOF MOLDING

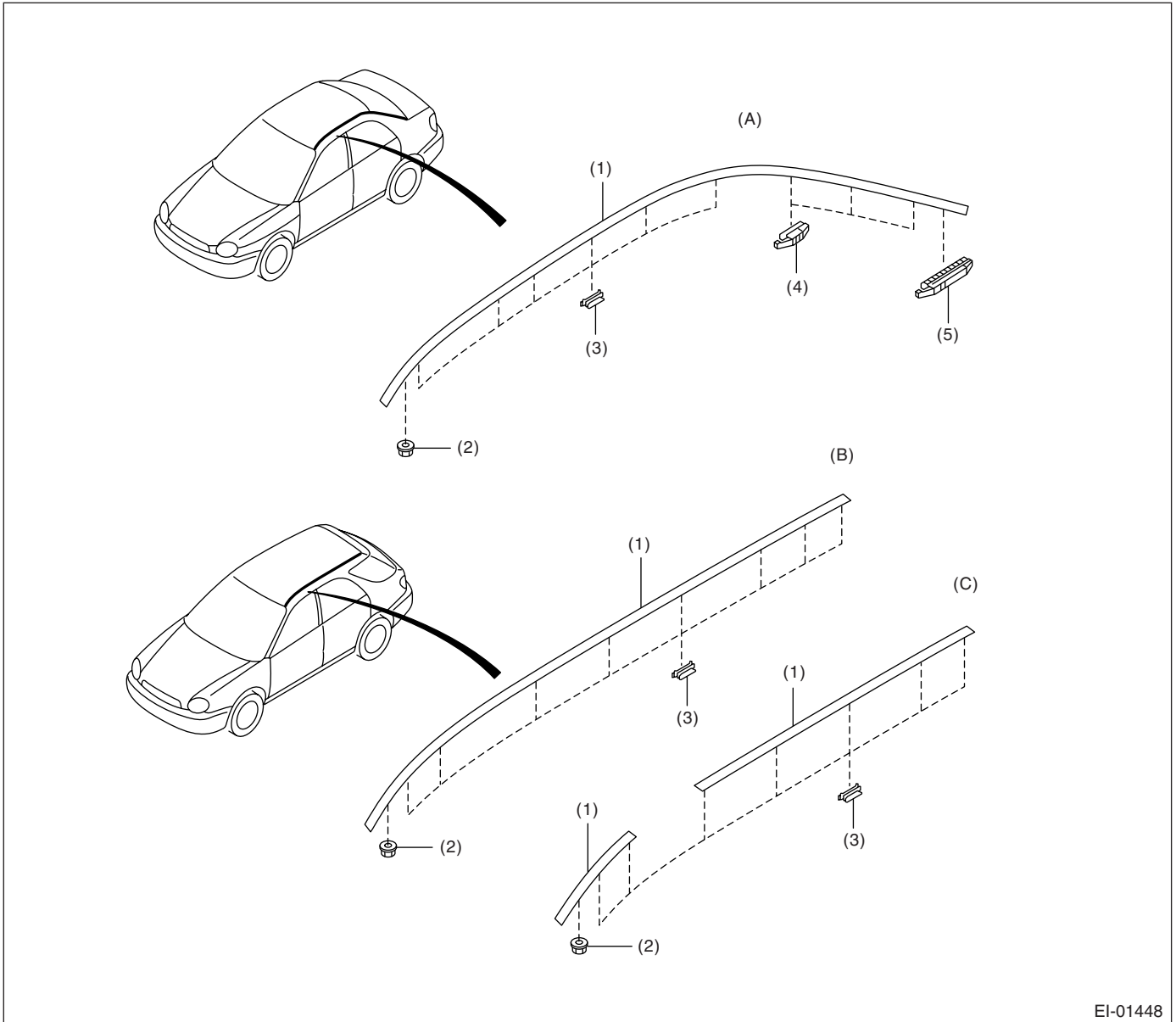

EI-01448

(A) Sedan model

(B) Wagon model

(C) Wagon model (with roof rail)

(1) Roof molding

(3) Clip B

(5) Clip D

(2) Clip A

(4) Clip C

# General Description

EXTERIOR/INTERIOR TRIM

## 12.ARCH COVER

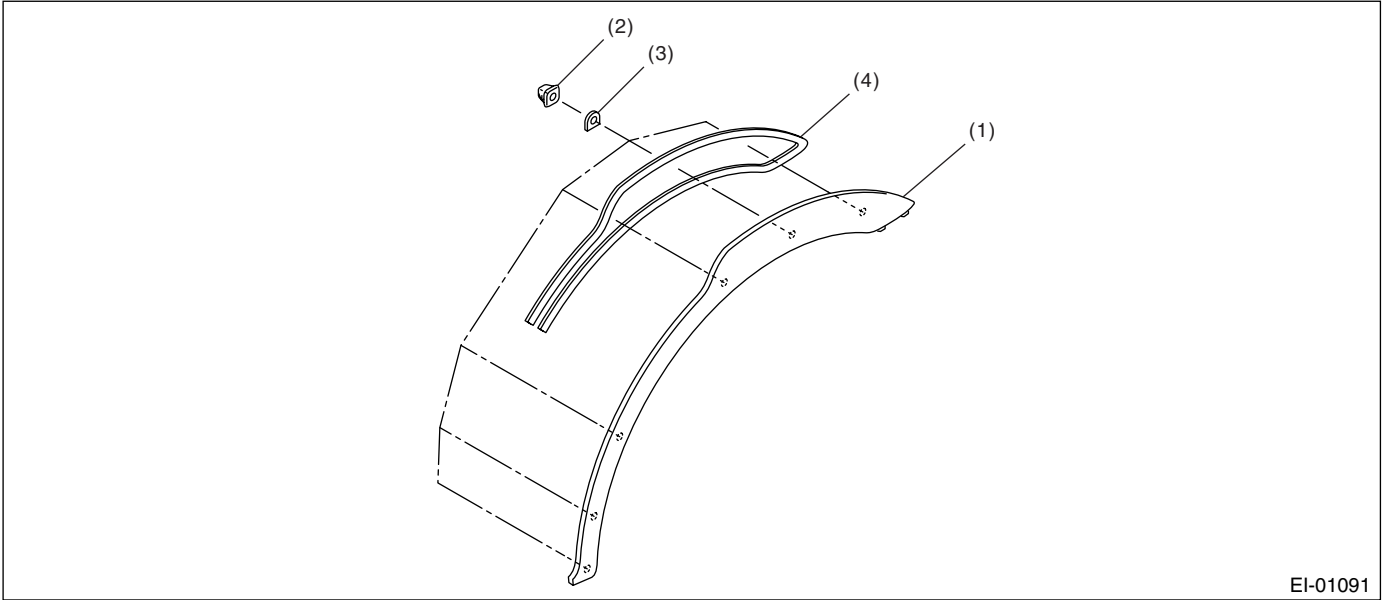

EI-01091

- (1) Arch cover
- (2) Clip

- (3) Cushion

- (4) Double-side tape

## 13.PROTECTOR

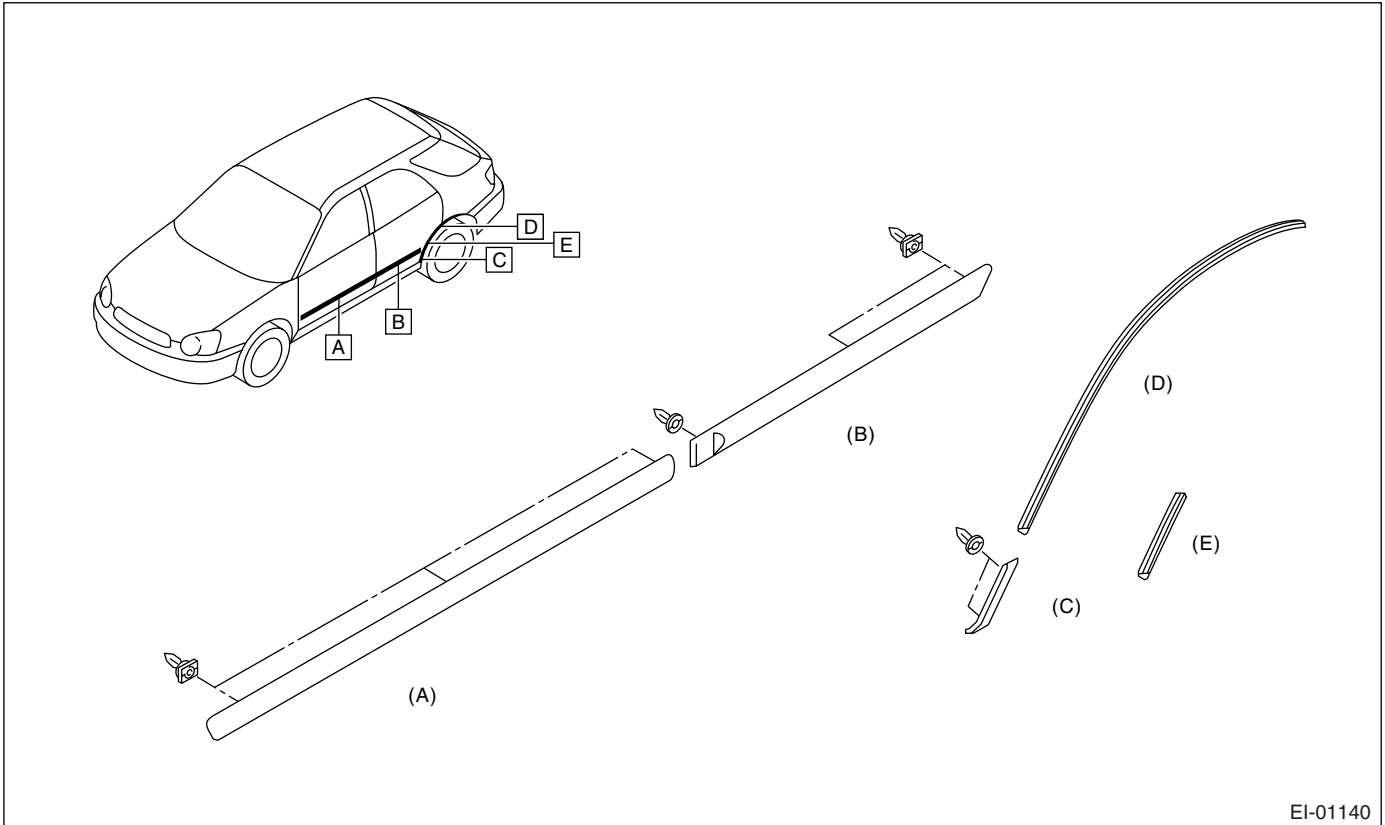

EI-01140

- (A) Front door
- (B) Rear door

- (C) Rear fender lower
- (D) Rear fender upper (Except STI model)

- (E) Rear fender upper (STI model)

## 14.DOOR TRIM

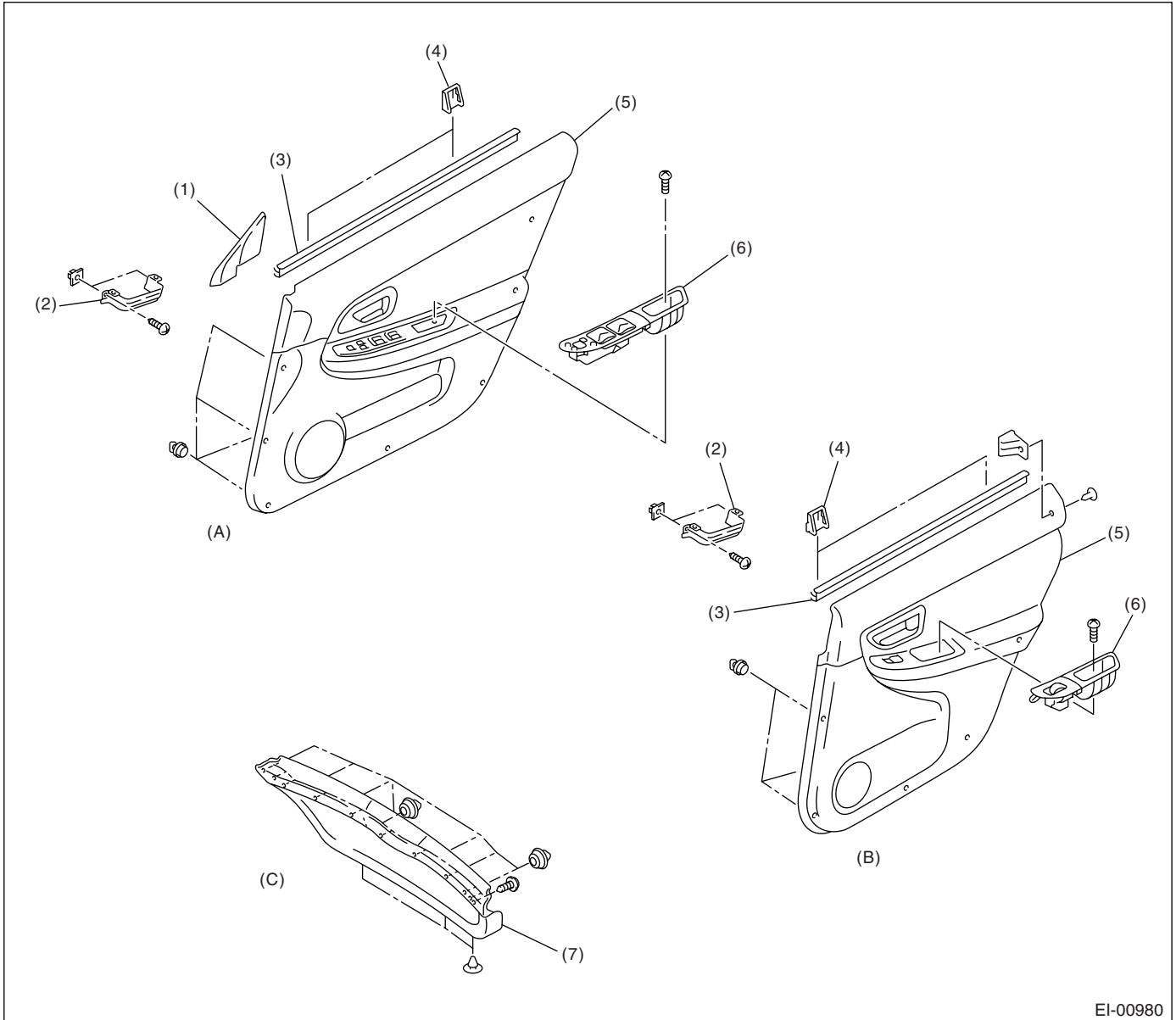

EI-00980

(A) Front door trim

(B) Rear door trim

(C) Rear gate trim

(1) Gusset cover

(4) Clip

(6) Power window switch cover

(2) Bracket

(5) Trim panel

(7) Lower trim

(3) Upper weather strip

# General Description

EXTERIOR/INTERIOR TRIM

## 15. CONSOLE BOX

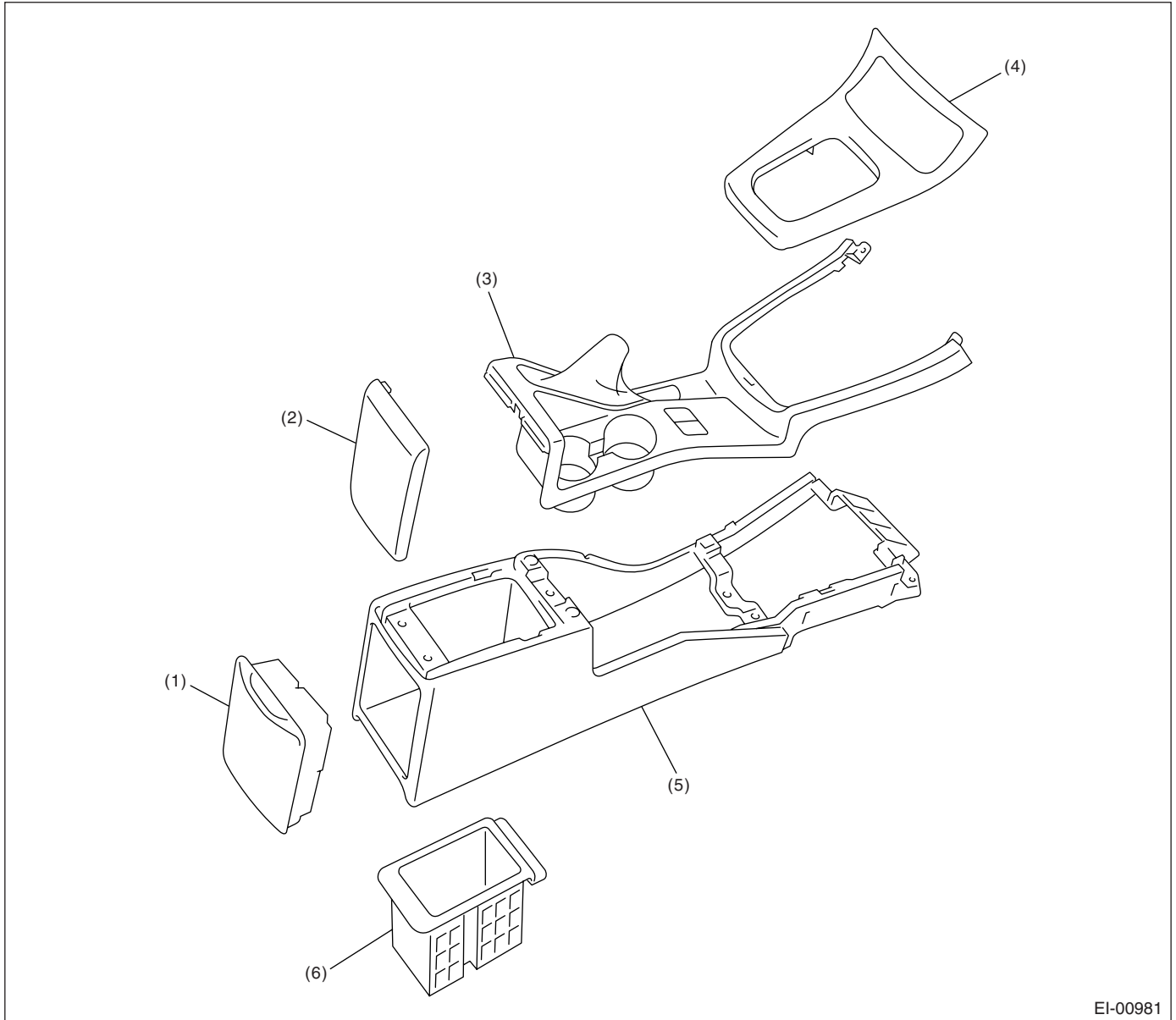

EI-00981

(1) Rear cup holders  
(2) Console lid

(3) Console cover  
(4) Console front panel

(5) Console box  
(6) Console pocket

## 16. INSTRUMENT PANEL

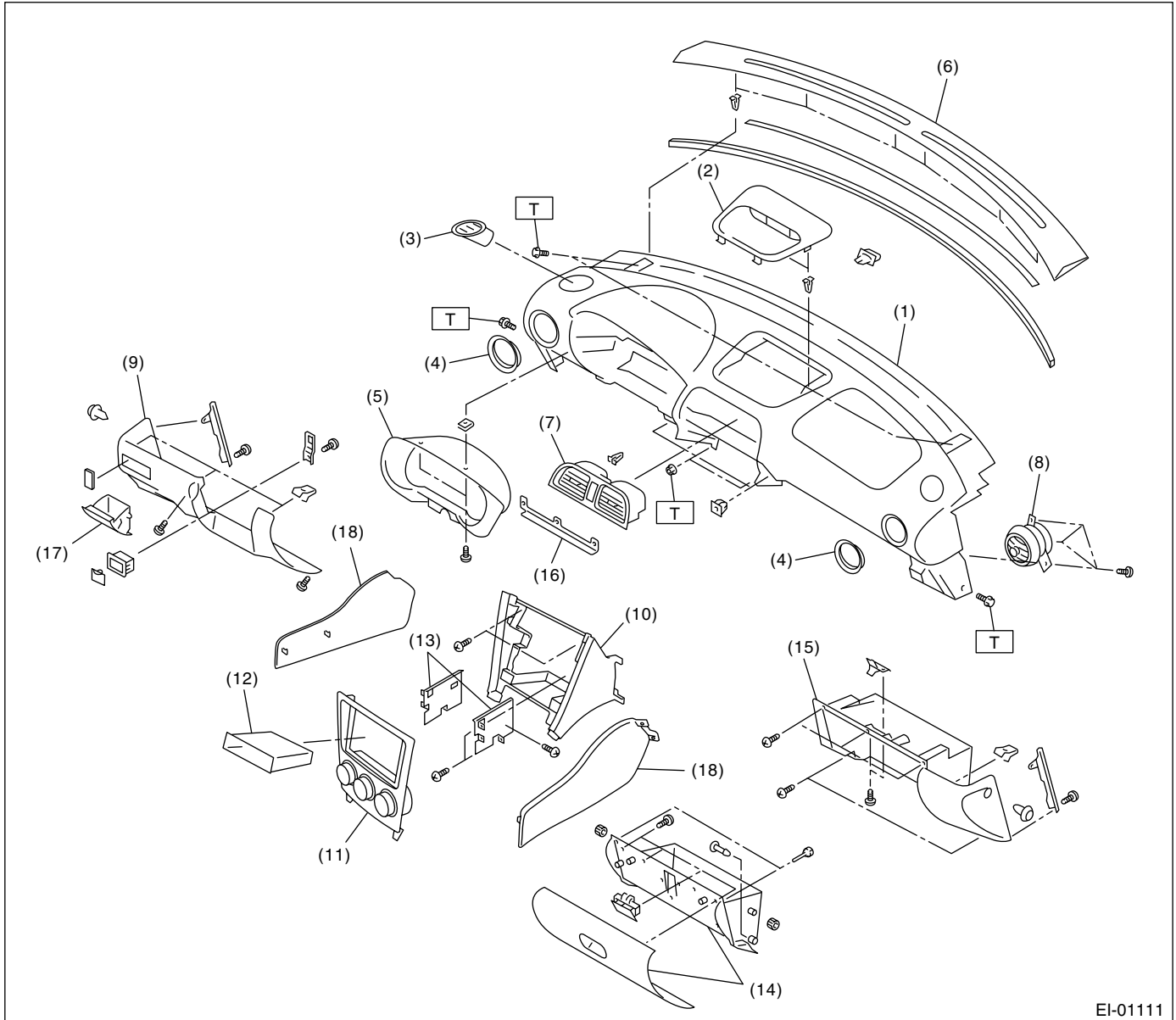

- |                                 |                                  |                         |
|---------------------------------|----------------------------------|-------------------------|
| (1) Pad & frame                 | (8) Air vent grille (side)       | (15) Glove box panel    |
| (2) Center upper panel          | (9) Instrument panel lower cover | (16) Bracket            |
| (3) Air vent grille (defroster) | (10) Console cover               | (17) Coin box           |
| (4) Grille cover                | (11) Center panel                | (18) Console side panel |
| (5) Meter visor                 | (12) Center pocket               |                         |
| (6) Defroster grille            | (13) Audio bracket               |                         |
| (7) Air vent grille (center)    | (14) Glove box lid               |                         |

**Tightening torque: N·m (kgf·m, ft·lb)**

**T: 7 (0.71, 5.2)**

# General Description

## EXTERIOR/INTERIOR TRIM

### 17.INNER TRIM (SEDAN MODEL)

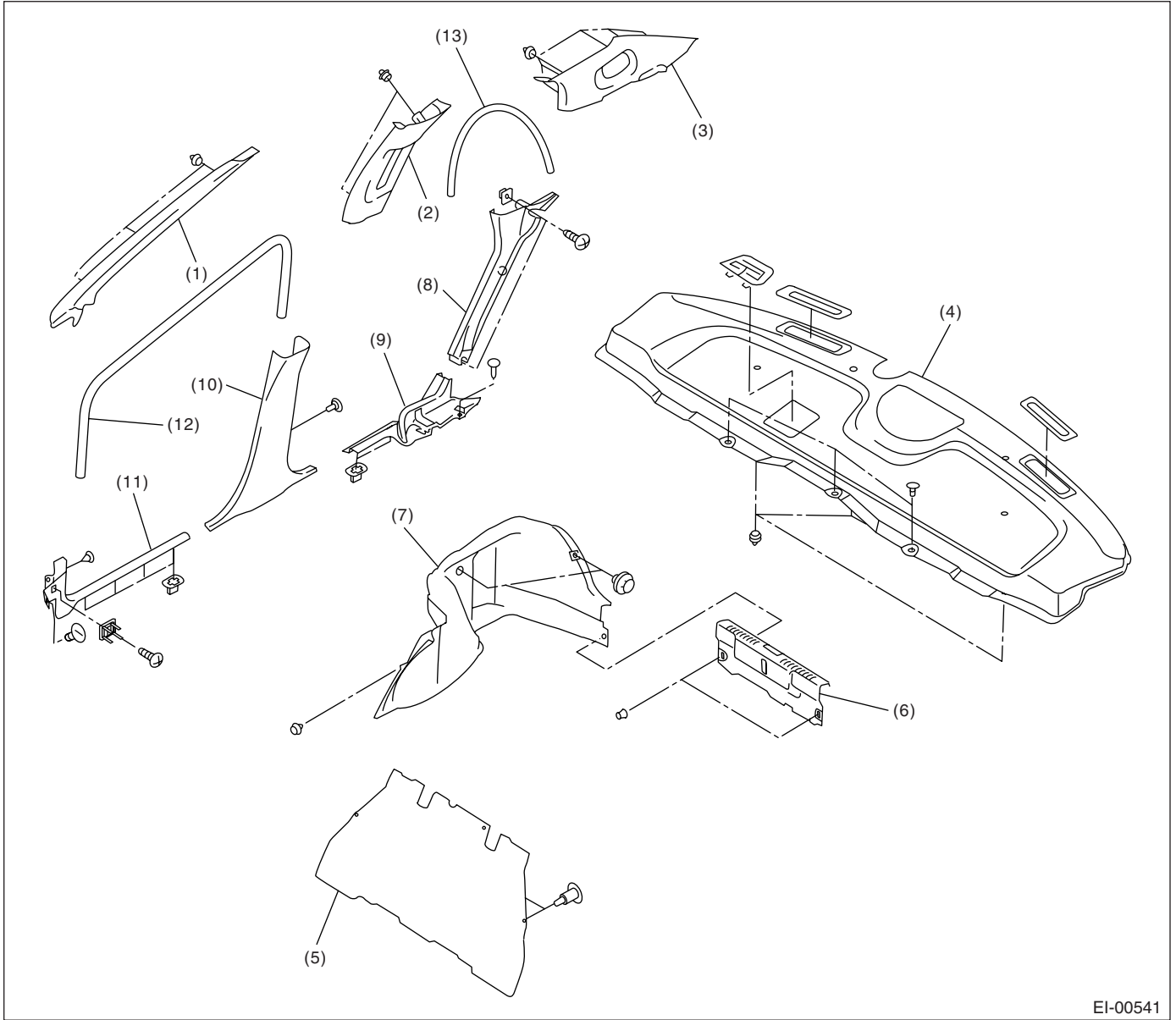

EI-00541

- |                              |                            |                               |
|------------------------------|----------------------------|-------------------------------|
| (1) Front pillar upper trim  | (6) Trunk rear trim        | (10) Center pillar lower trim |
| (2) Center pillar upper trim | (7) Trunk side trim        | (11) Side sill front cover    |
| (3) Rear pillar upper trim   | (8) Rear pillar lower trim | (12) Front garnish            |
| (4) Rear shelf trim          | (9) Side sill rear cover   | (13) Rear garnish             |
| (5) Rear bulk trim           |                            |                               |

## 18.INNER TRIM (WAGON MODEL)

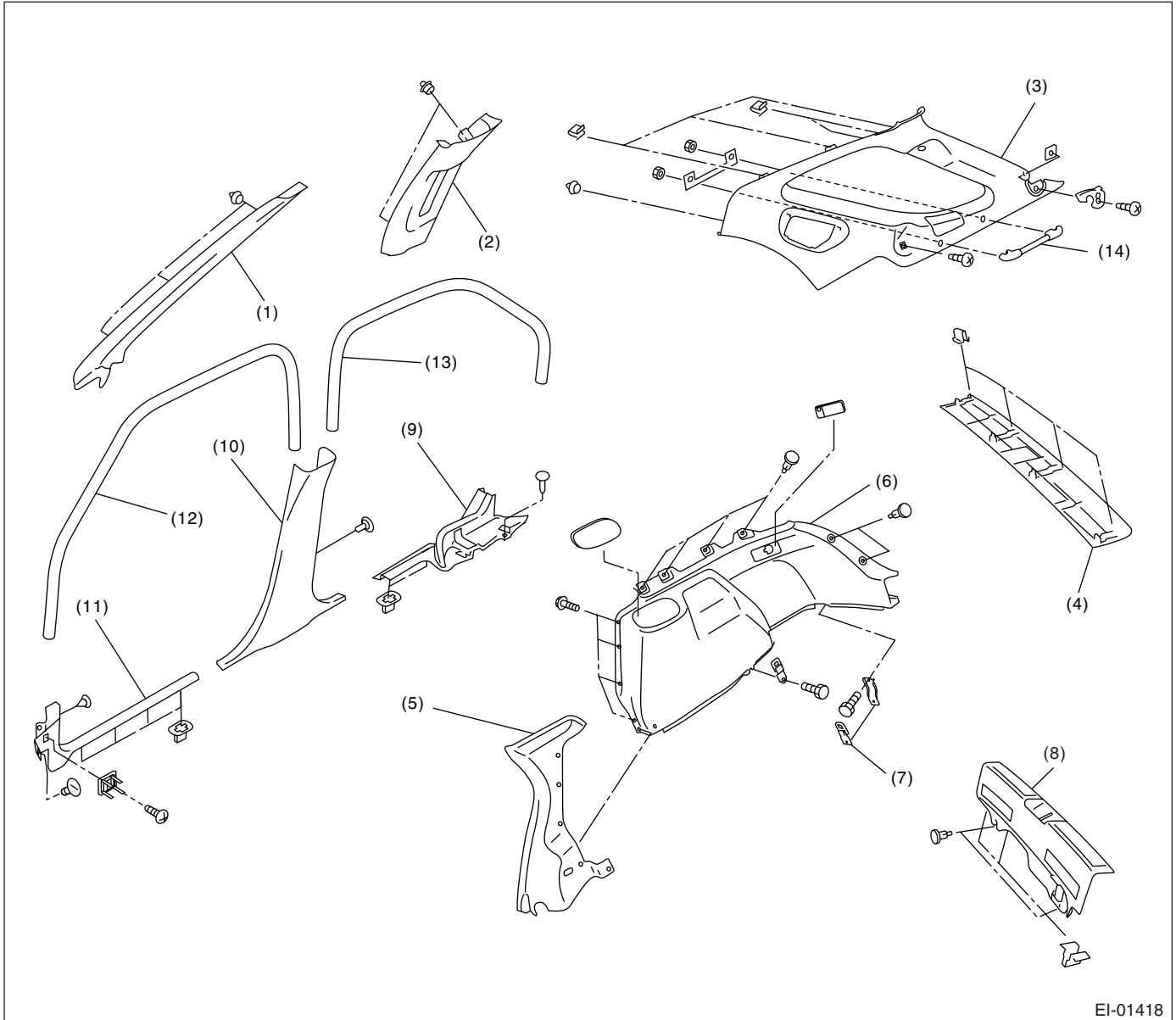

EI-01418

- |                              |                               |                                    |
|------------------------------|-------------------------------|------------------------------------|
| (1) Front pillar upper trim  | (6) Rear quarter lower trim   | (11) Side sill front cover         |
| (2) Center pillar upper trim | (7) Hook                      | (12) Front garnish                 |
| (3) Rear pillar upper trim   | (8) Rear skirt trim           | (13) Rear garnish                  |
| (4) Rear rail trim           | (9) Side sill rear cover      | (14) Luggage compartment side rail |
| (5) Rear pillar lower trim   | (10) Center pillar lower trim |                                    |

# General Description

EXTERIOR/INTERIOR TRIM

## 19. ROOF TRIM (SEDAN MODEL)

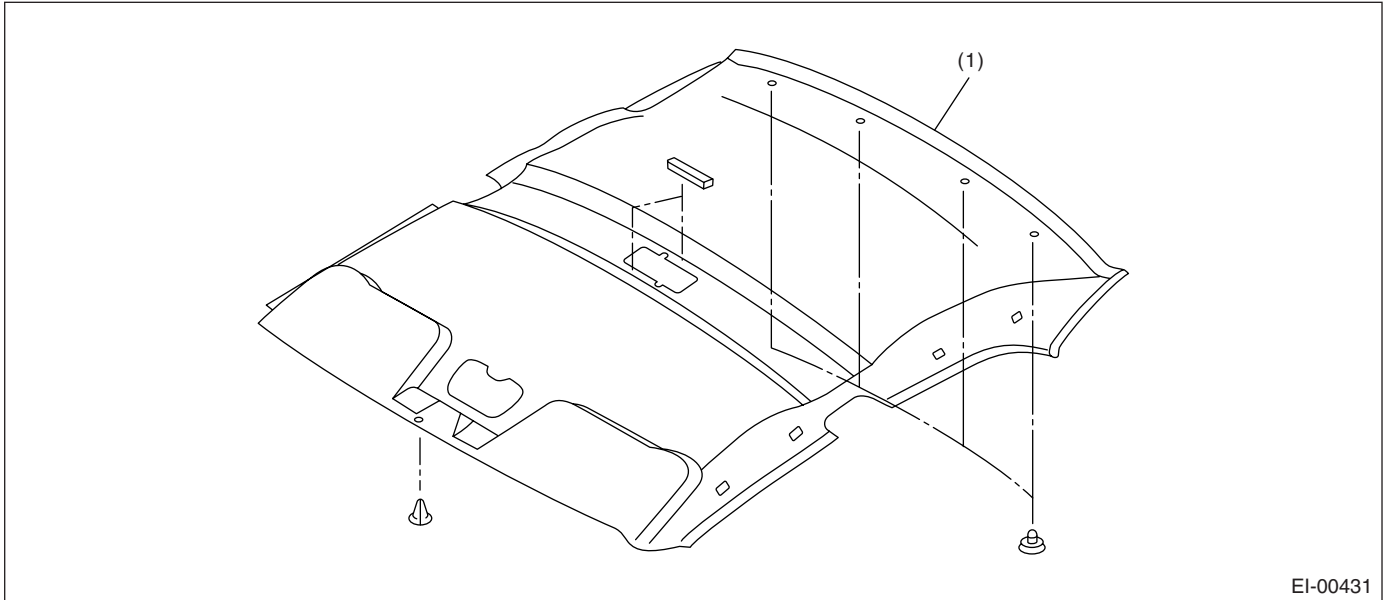

EI-00431

(1) Roof trim

## 20. ROOF TRIM (WAGON MODEL)

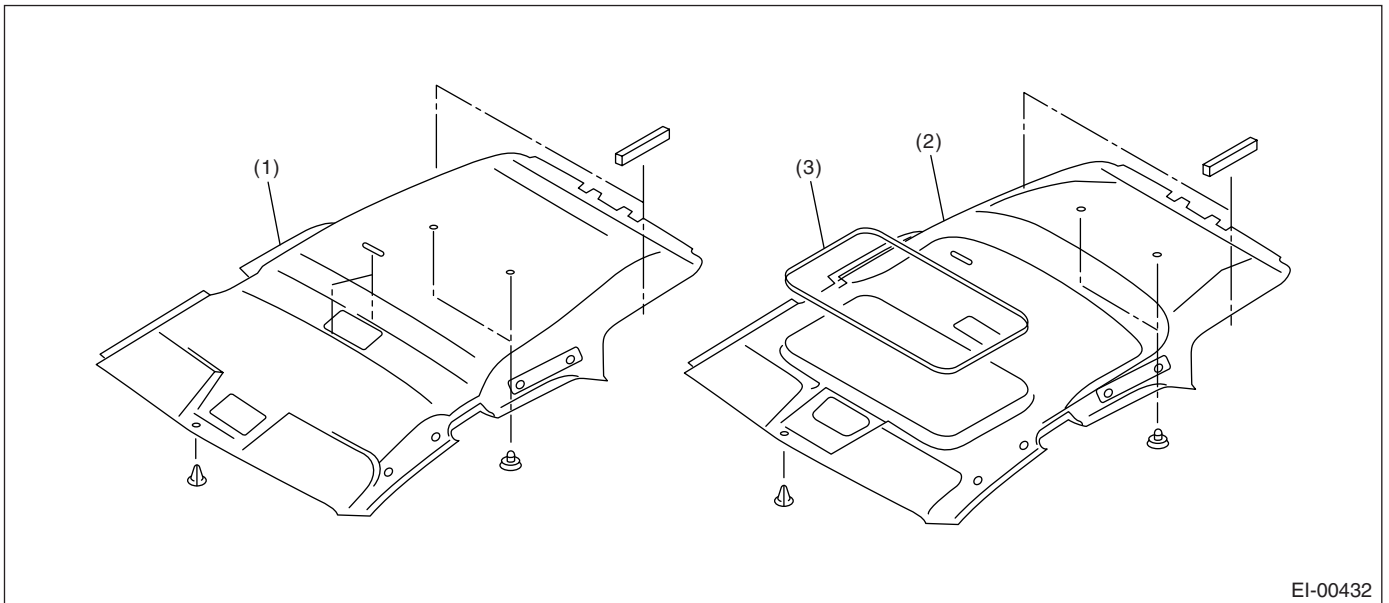

EI-00432

(1) Roof trim

(2) Roof trim (Model with sun roof)

(3) Sun roof garnish



## 21.LUGGAGE FLOOR MAT

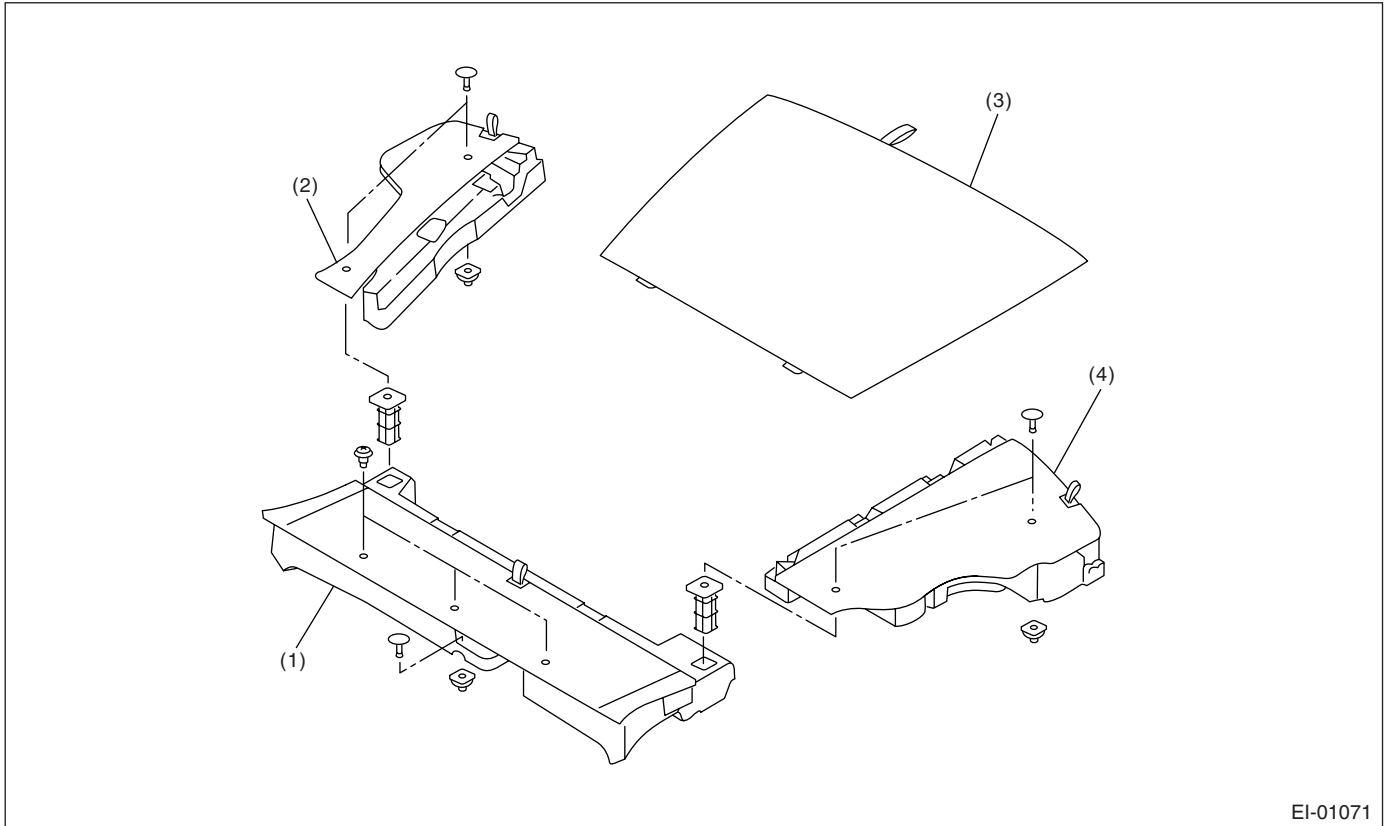

EI-01071

- (1) Front floor mat
- (2) Side floor mat (RH)
- (3) Center floor mat
- (4) Side floor mat (LH)

## 22.HEAT SHIELD COVER

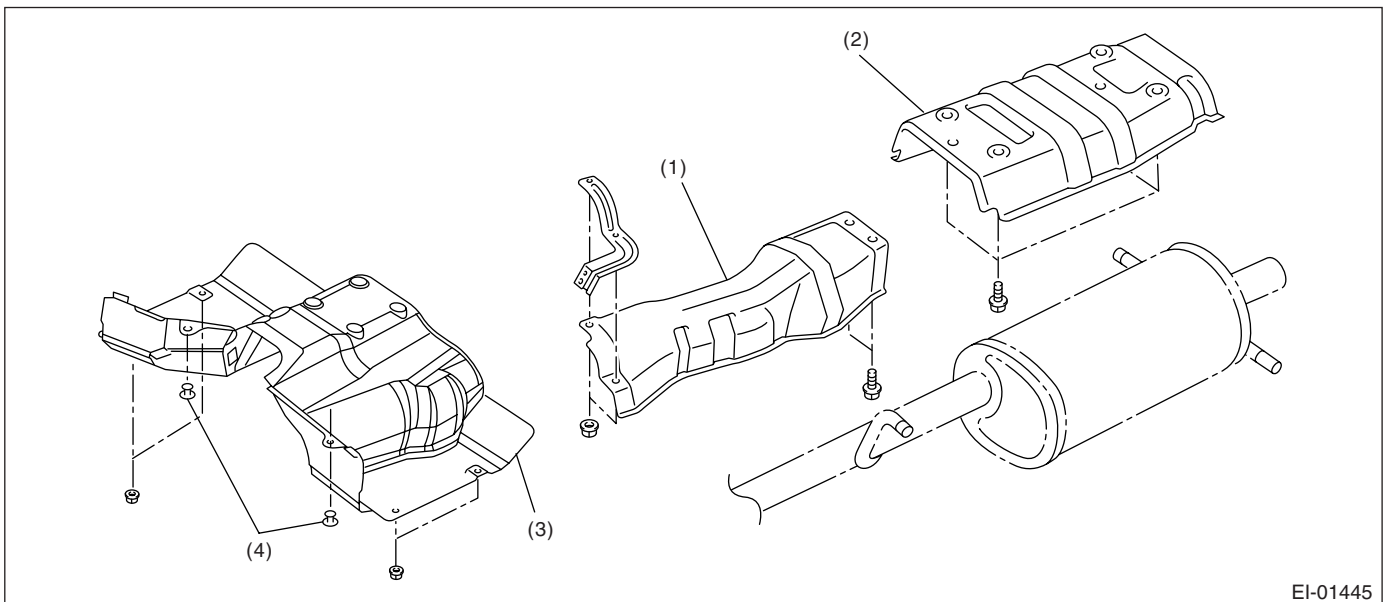

EI-01445

- (1) Center heat shield cover
- (2) Rear heat shield cover
- (3) Center heat shield cover (STI model)
- (4) Clip

# General Description

EXTERIOR/INTERIOR TRIM

## 23.INNER ACCESSORIES

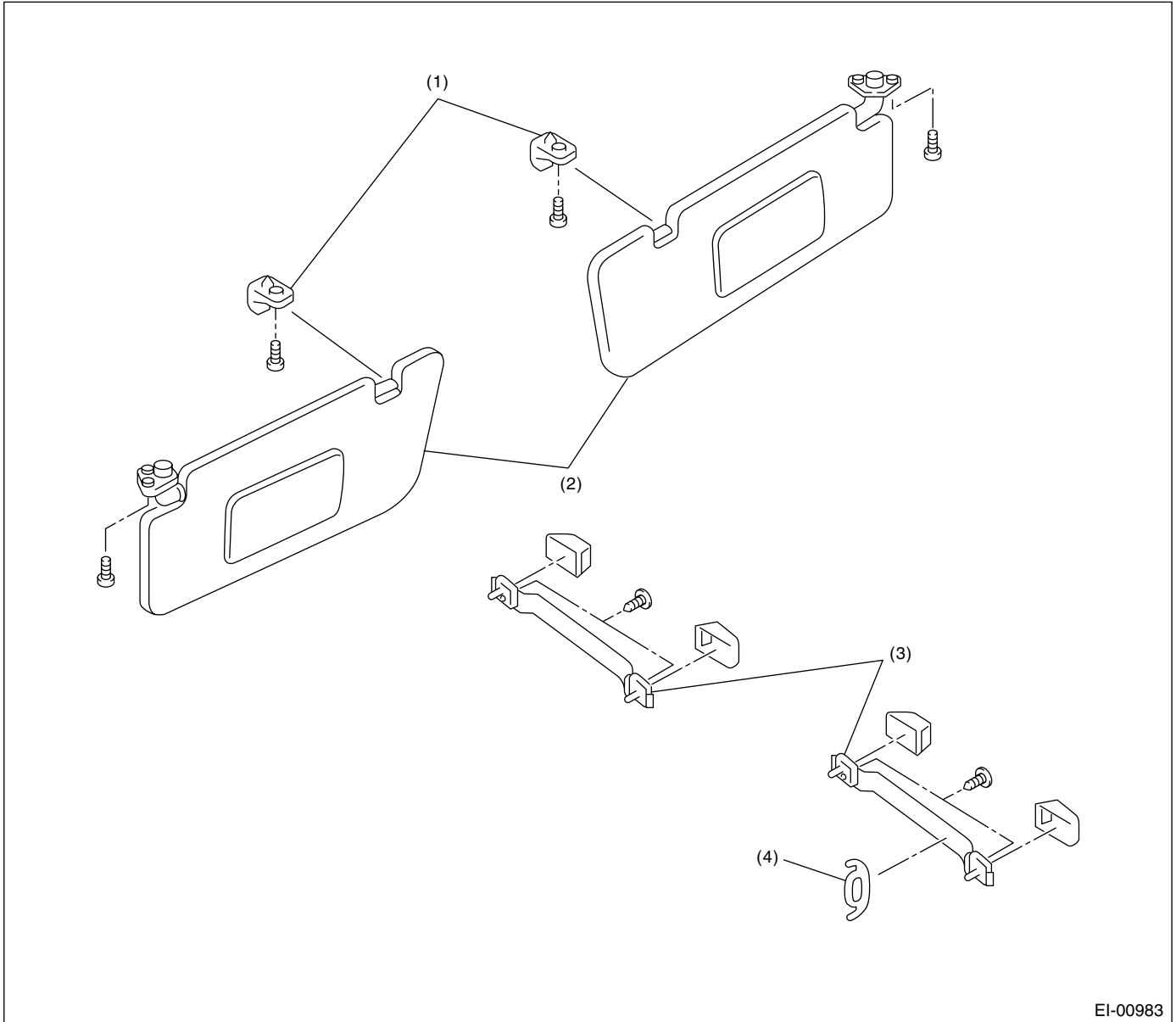

EI-00983

- (1) Hook
- (2) Sun visor

- (3) Assist grip

- (4) Coat hook

## 24.DIFFUSER

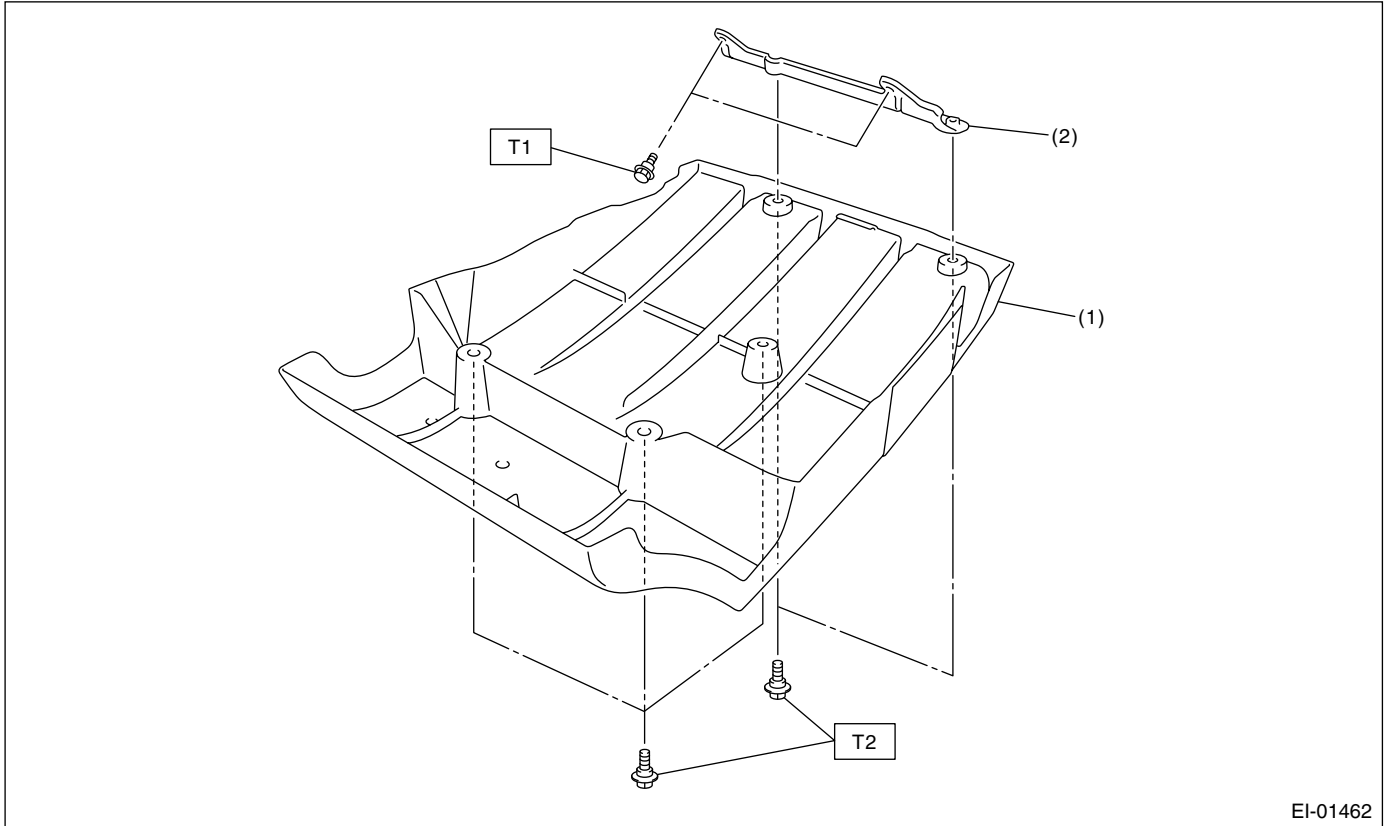

EI-01462

(1) Rear diffuser

(2) Diffuser bracket

**Tightening torque: N-m (kgf-m, ft-lb)**

**T1: 7.5 (0.76, 5.5)**

**T2: 14 (1.4, 10.3)**

## B: PREPARATION TOOL

TOOL NAME	REMARKS
Clip remover	Used for removal of trim.
Clip clamp pliers	Used for removal of various clips and clamps.

# Front Grille

EXTERIOR/INTERIOR TRIM

## 2. Front Grille

### A: REMOVAL

1) Remove the six clips (A).

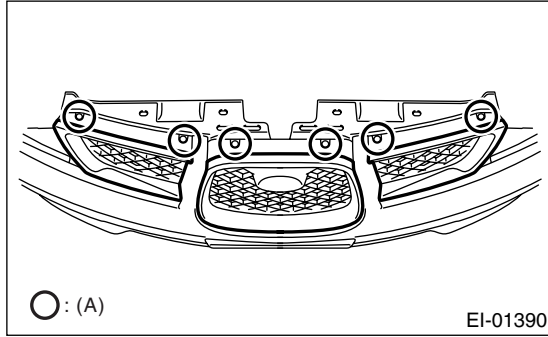

(A) Clip

2) Remove the clip on the upper side and the hooks on the right, left and lower sides, and remove the grille LH, grille RH and grille center.

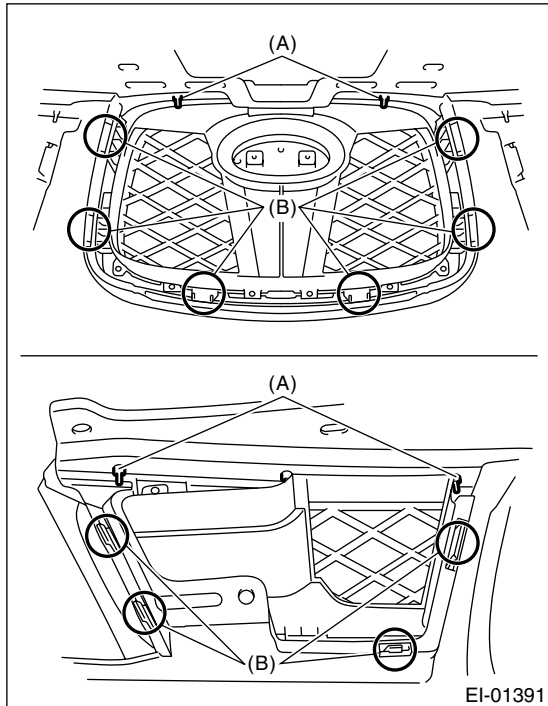

(A) Clip

(B) Hook

3) Remove the screw and disassemble front grille.

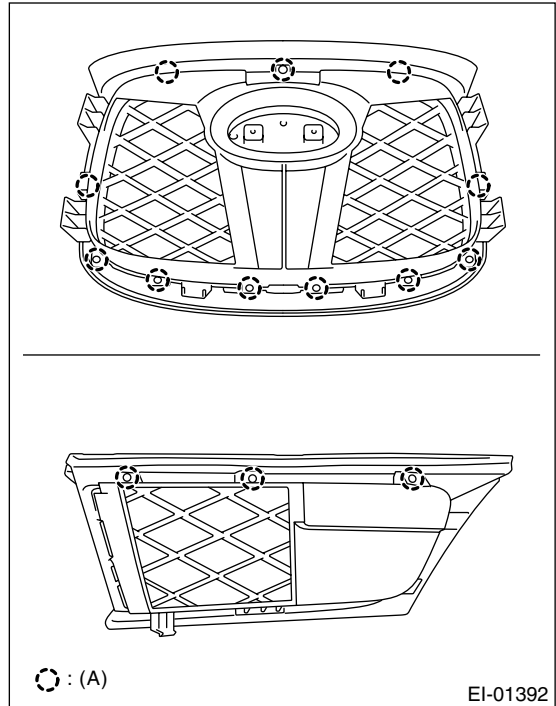

(A) Screw

### B: INSTALLATION

Install in the reverse order of removal.

## 3. Front Hood Grille

### A: REMOVAL

- 1) Open the front hood.
- 2) Remove the intercooler water spray hose. (STI model)
- 3) Remove the seven bolts and clip (A) to remove the hood duct.

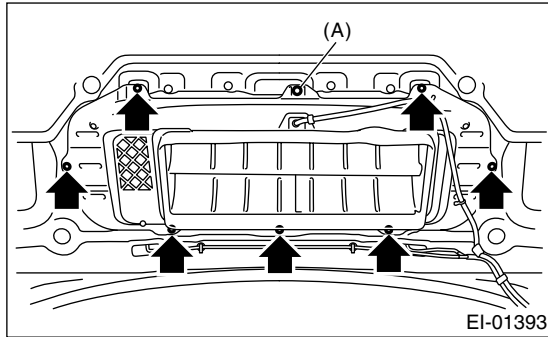

- 4) Loosen the six nuts (B), remove the four clips (A), and then remove the hood grille.

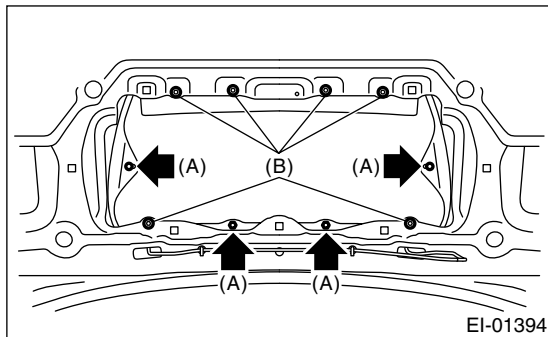

### B: INSTALLATION

- 1) Replace the four clips with new ones.

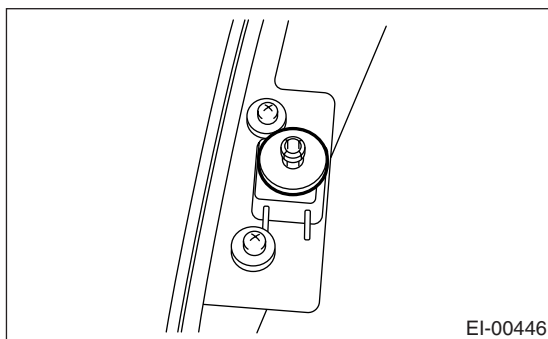

- 2) Engage the four clips of hood grille to front hood panel.

### CAUTION:

Make sure that the anchor portion of each clip is firmly engaged.

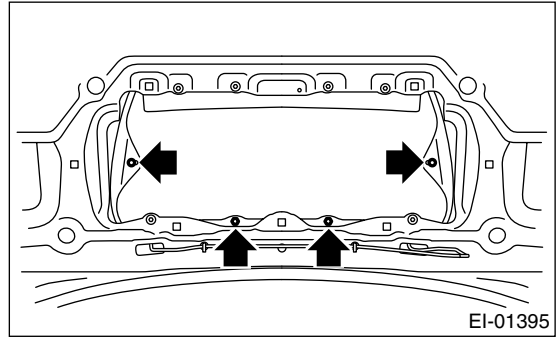

- 3) Install the six nuts.

### Tightening torque:

4.5 N·m (0.46 kgf·m, 3.32 ft·lb)

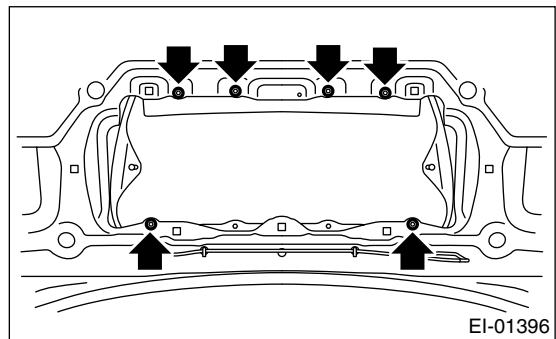

- 4) Catch the two hooks (A) of hood duct to hood holes.

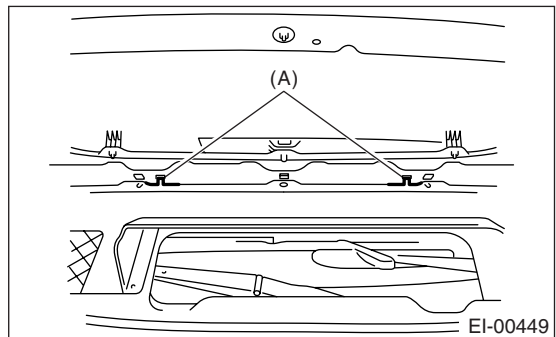

- 5) Install the hood duct with clip (A) and seven bolts.

## Front Hood Grille

EXTERIOR/INTERIOR TRIM

---

### **Tightening torque:**

**1.0 N·m (0.1 kgf-m, 0.74 ft-lb)**

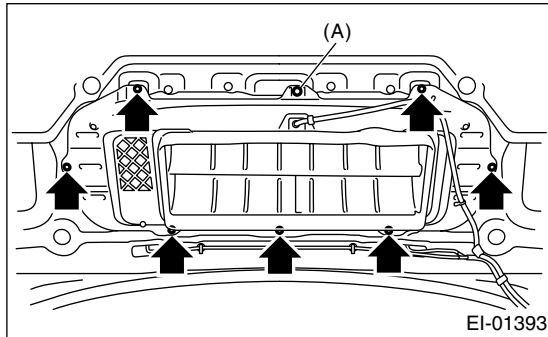

6) Install the intercooler water spray hose. (STI model)

### **C: INSPECTION**

Make sure that the clip is firmly engaged.

Make sure that there is no abnormal gap at whole periphery of hood grille.

Make sure that there is no damage on hood grille.

## 4. Front Under Cover

### A: REMOVAL

- 1) Lift-up the vehicle.
- 2) Remove the bolts and clips to remove under cover.

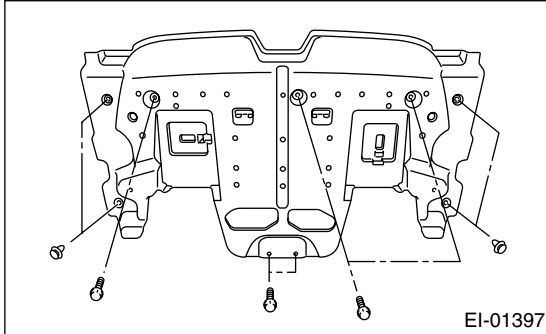

### B: INSTALLATION

Install in the reverse order of removal.

#### *Tightening torque:*

**14 N·m (1.4 kgf-m, 10.3 ft-lb)**

# Front Bumper

EXTERIOR/INTERIOR TRIM

## 5. Front Bumper

### A: REMOVAL

- 1) Disconnect the ground cable from battery.
- 2) Remove the front grille RH and front grille LH. <Ref. to EI-20, REMOVAL, Front Grille.>
- 3) Remove the clips inside the mounting portion of front grille RH and front grille LH.

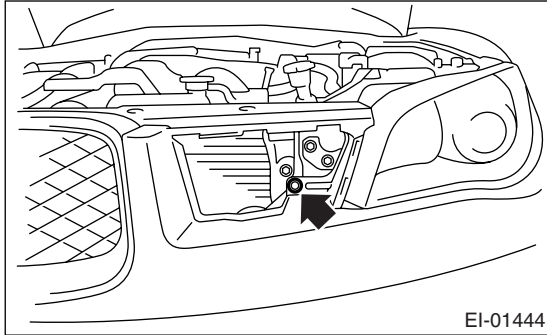

- 4) Remove the six clips on the upper part of bumper.

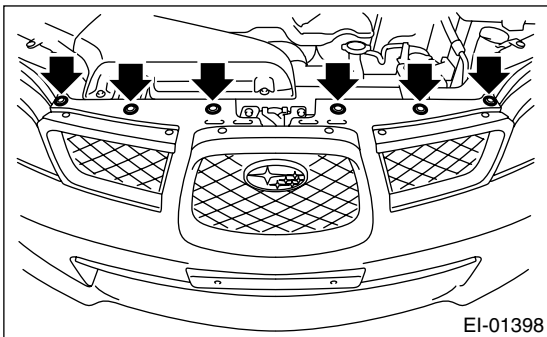

- 5) Remove the clips, which secure the front bumper to fender.

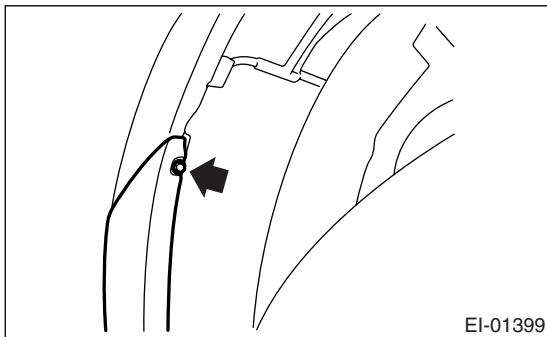

- 6) Remove the clips, and turn over the mud guard LH and RH.

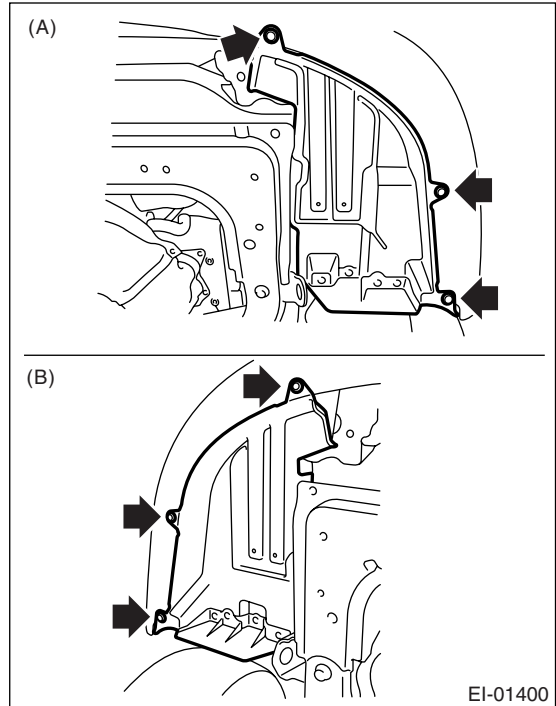

- (A) Mud guard (LH)  
(B) Mud guard (RH)

- 7) Remove the three clips in the center, right and left part of bumper.

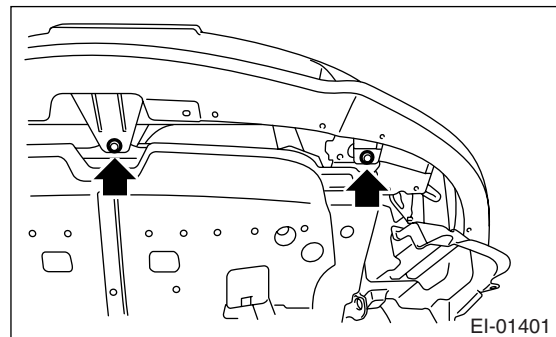

- 8) Remove the fog light. <Ref. to LI-19, REMOVAL, Front Fog Light Assembly.>
- 9) Remove the bumper from body.
- 10) Remove the energy absorber foam from front bumper beam.

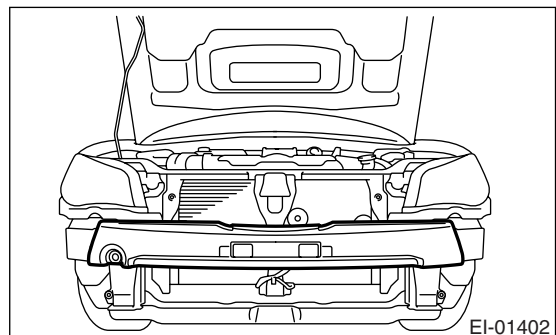



11) Loosen the bolt and nut, and then remove the bumper beam from body.

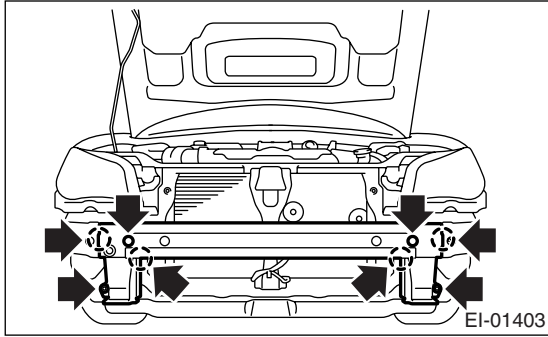

## B: INSTALLATION

1) Install in the reverse order of removal.  
2) Align the front bumper mounting hole with the pawl of slider (A) to install.

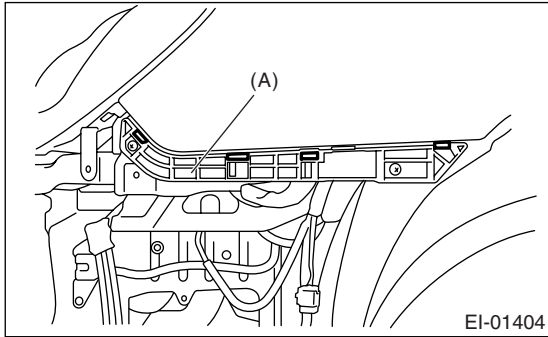

### **Tightening torque:**

**Refer to COMPONENT in General Description.**

**<Ref. to EI-4, FRONT BUMPER, COMPONENT, General Description.>**

# Front Bumper

EXTERIOR/INTERIOR TRIM

## C: REPAIR

### 1. COATING METHOD FOR PP BUMPER

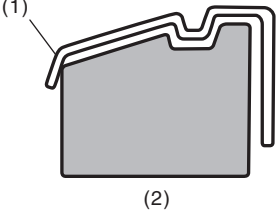
Process No.	Process name	Job contents	
1	Bumper mounting	Set the bumper on paint worktable if required. Use paint worktable conforming to inner shape of bumper when possible.	 <p>(1) Bumper (2) Set bumper section</p> <p>EI-00234</p>
2	Masking	Mask specified part (black base) with masking tape. Use masking tape for PP (example, Nichiban No. 533, etc.).	
3	Degreasing, cleaning	Clean all parts to be painted with white gasoline, normal alcohol, etc. to remove dirt, oil, fat, etc.	
4	Primer paint	Apply primer one to all parts to be painted, using air gun. Use primer (clear).	
5	Drying	Dry at normal temperature [10 to 15 min. at 20°C (68°F)]. In half-dried condition, PP primer paint is dissolved by solvent, e.g. thinner, etc. Therefore, if dust or dirt must be removed, use ordinary alcohol, etc.	
6	Top coat paint (I)	Solid color	Metallic color
		Use section (block) paint for top coat. • Paint in use (for each color): Solid paint Hardener PB Thinner T-301 • Mixing ratio: Main agent vs. hardener = 4:1 • Viscosity: 10 — 13 sec/20°C (68°F) • Film thickness: 35 — 45μ • Spraying pressure: 245 — 343 kPa (2.5 — 3.5 kgf/cm <sup>2</sup> , 36 — 50 psi)	Use section (block) paint for top coat. • Paint in use (for each color): Metallic paint Hardener PB Thinner T-306 • Mixing ratio: Main agent vs. hardener = 10:1 • Viscosity: 10 — 13 sec/20°C (68°F) • Film thickness: 15 — 20μ • Spraying pressure: 245 — 343 kPa (2.5 — 3.5 kgf/cm <sup>2</sup> , 36 — 50 psi)
7	Drying	Not required.	Dry at normal temperature [10 min. or more at 20°C (68°F)]. In half-dried condition, avoid dust, dirt.
8	Top coat paint (II)	Not required.	Apply a clear coat to parts with top coat paint (I), three times, at 5 — 7 minutes intervals. • Paint in use: Metallic paint Hardener PB Thinner T-301 • Mixing ratio: Clear vs. hardener = 6:1 • Viscosity: 14 — 16 sec/20°C (68°F) • Film thickness: 25 — 30μ • Spraying pressure: 245 — 343 kPa (2.5 — 3.5 kgf/cm <sup>2</sup> , 36 — 50 psi)
9	Drying	60°C (140°F), 60 min. or 80°C (176°F), 30 min. If higher than 80°C (176°F), PP may be deformed. Keep maximum temperature of 80°C (176°F).	
10	Inspection	Paint check.	
11	Masking removal	Remove the masking in process No. 2.	

## 2. REPAIR INSTRUCTIONS FOR COLORED PP BUMPER

**NOTE:**

All PP bumpers are provided with a grained surface, and if the surface is damaged, it cannot normally be restored to its former condition. Damage limited to shallow scratches that cause only a change in the lustre of the base material or coating, can be almost fully restored. Before repairing a damaged area, explain this point to the customer and get an understanding about the matter. Repair methods are outlined below, based on a classification of the extent of damage.

1) Minor damage causing only a change in the lustre of the bumper due to a light touch  
Almost restorable.

Process No.	Process name	Job contents	
1	Cleaning	Clean the area to be repaired using water.	
2	Sanding	Grind the repairing area with #500 sand paper in a "feathering" motion.	
3	Finish	Resin section	Coated section
		Repeatedly apply wax to the affected area using a soft cloth (such as flannel). Recommended wax: NITTO KASEI Soft 99 TIRE WAX BLACK, or equivalent.	
		Polish the waxed area with a clean cloth after 5 to 10 minutes.	
		Perform either the same operation as for the resin section or process No. 18 and subsequent operations in the "3)" section, depending on the degree and nature of damage.	

2) Deep damage caused by scratching fences, etc.  
A dent cannot be repaired but a whitened or swelled part can be removed.

Process No.	Process name	Job contents	
1	Cleaning	Clean the damaged area with water.	
2	Removal of damaged area	Cut off protruding area, if any, due to collision, using a putty knife.	
3	Sanding	Grind the affected area with #100 to #500 sand paper.	
4	Finish	Resin section	Coated section
		Same as Process No. 3 in the "1)" section.	
		Perform Process No. 12 and subsequent operations in the "3)" section.	

3) Deep damage such as a break or hole that requires filling  
Much of the peripheral grained surface must be sacrificed for repair, and the degree of restoration is not really worth the expense. (The surface, however, will become almost flush with adjacent areas.)  
Recommended repair kit: PP Part Repair Kit (NRM)

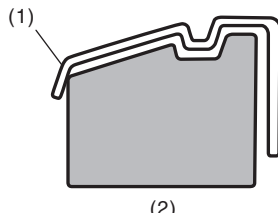
Process No.	Process name	Job contents	
1	Bumper removal	Remove the bumper as required.	
2	Part removal	Remove the parts built into bumper as required.	
3	Bumper placement	Place the bumper on a paint worktable as required. It is recommended that contour of worktable accommodate internal shape of bumper.	 <p style="text-align: right;">EI-00234</p>
4	Surface preparation	Remove dust, oil, etc. from areas to be repaired and surrounding areas, using a suitable solvent (NRM No. 900 Precleno, white gasoline, or alcohol).	

# Front Bumper

## EXTERIOR/INTERIOR TRIM

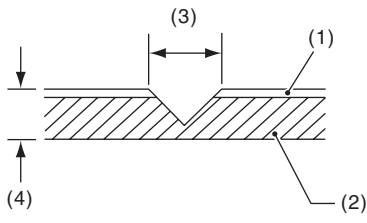
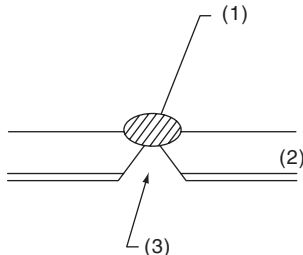
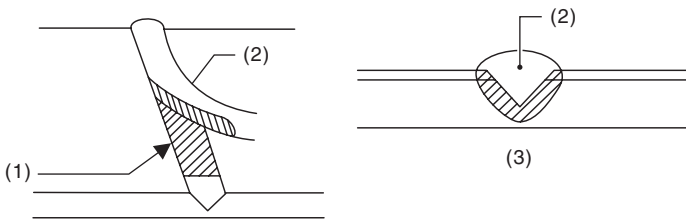
Process No.	Process name	Job contents	
5	Cutting	<p>If nature of damage are cracks or holes, cut a guide slit of 20 to 30 mm (0.79 to 1.18 in) in length along the crack or hole up to the bumper's base surface. Then, bevel or "vee-out" the affected area using a knife or grinder.</p>	 <p style="text-align: right;">EI-00235</p> <p>(1) Paint surface            (2) PP base surface            (3) 20 — 30 mm (0.79 — 1.18 in)            (4) 3 mm (0.12 in)</p>
6	Sanding (I)	Grind beveled surface with sand paper (#40 to #60) to smooth finish.	
7	Cleaning	Clean the sanded surface with the same solvent as used in Process No. 4.	
8	Temporary welding	<p>Grind the side just opposite the beveled area with sand paper (#40 to #60) and clean using a solvent.            Temporarily spot-weld the side, using a PP welding rod and heater gun.</p>	 <p style="text-align: right;">EI-00236</p> <p>(1) Welded spot (Use heater gun and PP welding rod)            (2) PP base surface            (3) Beveled section</p> <p>NOTE:</p> <ul style="list-style-type: none"> <li>Do not melt the welding rod until it flows out. This results in reduced strength.</li> <li>Leave the welded spot unattended until it cools completely.</li> </ul>
9	Welding	<p>Using a heater gun and PP welding rod, weld the beveled spot while melting the rod and damaged area.</p>	 <p style="text-align: right;">EI-00237</p> <p>(1) Melt hatched area            (2) Welding rod            (3) Section</p> <p>NOTE:</p> <ul style="list-style-type: none"> <li>Melt the sections indicated by hatched area.</li> <li>Do not melt the welding rod until it flows out, in order to provide strength.</li> <li>Always keep the heater gun 1 to 2 cm (0.4 to 0.8 in) away from the welding spot.</li> <li>Leave the welded spot unattended until it cools completely.</li> </ul>

# Front Bumper

EXTERIOR/INTERIOR TRIM

Process No.	Process name	Job contents
10	Sanding (II)	Remove excess part of weld with a putty knife. If a drill or disc wheel is used instead of the knife, operate it at a rate lower than 1,500 rpm and grind the excess part little by little. A higher rpm will cause the PP substrate to melt from the heat.
		 <p style="text-align: right;">EI-00042</p>
		Sand the welded spot smooth with #240 sand paper.
11	Masking	Mask the black substrate section using masking tape. Recommended masking tape: Nichiban No. 533 or equivalent
12	Cleaning/ degreasing	Completely clean the entire coated area, using solvent similar to that used in Process No. 4.
13	Primer coating	Apply a coat of primer to the repaired surface and its surrounding areas. Mask these areas, if necessary. Recommended primer: Mp/ 364 PP Primer NOTE: Be sure to apply one coat of primer at a spraying pressure of 245 to 343 kPa (2.5 to 3.5 kgf/cm <sup>2</sup> , 36 to 50 psi) with a spray gun.
14	Leave unattended.	Leave the repaired area unattended at 20°C (68°F) for 10 to 15 minutes until primer is half-dry. NOTE: If dirt or dust comes in contact with the coated area, wipe it off with a cloth impregnated with alcohol. (Do not use thinner since the coated area tends to melt.)
15	Primer surfacer coating	Apply a coat of primer surfacer to the repaired area two or three times at an interval of 3 to 5 minutes. Recommended surfacer: <ul style="list-style-type: none"> <li>• UPS 300 Flex Primer</li> <li>• No. 303 UPS 300 Exclusive hardener</li> <li>• NPS 725 Exclusive Reducer (thinner)</li> <li>• Mixing ratio: 2: 1 (UPS 300: No. 303)</li> <li>• Viscosity: 12 — 14 sec/20°C (68°F)</li> <li>• Coated film thickness: 40 — 50μ</li> </ul>
16	Drying	Allow the coated surface to dry for 30 minutes at 20°C (68°F) or 20 minutes at 60°C (140°F).
17	Sanding (III)	Sand the coated surface and its surrounding areas using #400 sand paper and water.
18	Cleaning/ degreasing	Same as Process No. 12.
19	Top coat (I)	Solid color
		<p>Use a “block” coating method.</p> <ul style="list-style-type: none"> <li>• Recommended paint: Suncryl (SC)</li> <li>• No. 307 Flex Hardener</li> <li>• SC Reducer (thinner)</li> <li>• Mixing ratio: 3: 1</li> </ul> <p>Suncryl (SC) vs. No. 307 Flex Hardener</p> <ul style="list-style-type: none"> <li>• Viscosity: 11 — 13 sec/20°C (68°F)</li> <li>• Coated film thickness: 40 — 50μ</li> <li>• Spraying thickness: 245 — 343 kPa (2.5 — 3.5 kgf/cm<sup>2</sup>, 36 — 50 psi)</li> </ul>
		Metallic color
		<p>Use a “block” coating method.</p> <ul style="list-style-type: none"> <li>• Recommended paint: Suncryl (SC)</li> <li>• No. 307 Flex Hardener</li> <li>• SC Reducer (thinner)</li> <li>• Mixing ratio: 3: 1</li> </ul> <p>Suncryl (SC) vs. No. 307 Flex Hardener</p> <ul style="list-style-type: none"> <li>• Viscosity: 11 — 13 sec/20°C (68°F)</li> <li>• Coated film thickness: 20 — 30μ</li> <li>• Spraying thickness: 245 — 343 kPa (2.5 — 3.5 kgf/cm<sup>2</sup>, 36 — 50 psi)</li> </ul>

# Front Bumper

## EXTERIOR/INTERIOR TRIM

Process No.	Process name	Job contents	
20	Leave unattended.	Not required.	Leave unattended at 20°C (68°F) for at least 10 minutes until the topcoated area is half-dry. NOTE: Be careful to keep dust or dirt from coming in contact with the affected area.
21	Top coat (II)	Not required.	Apply a clear coat three times at an interval of 3 to 5 minutes. • Recommended paint: SC710 Overlay Clear No. 307 Flex Hardener SC Reducer (thinner) • Mixing ratio: 3: 1 Suncryl (SC) vs. No. 307 Flex Hardener • Viscosity: 10 — 13 sec/20°C (68°F) • Coated film thickness: 20 — 30μ • Spraying pressure: 245 — 343 kPa (2.5 — 3.5 kg/cm <sup>2</sup> , 36 — 50 psi)
22	Drying	Allow the coated surface to dry at 20°C (68°F) for two hours or 60°C (140°F) for 30 minutes. NOTE: Do not allow the temperature to exceed 80°C (176°F) since this will deform the PP substrate.	
23	Inspection	Carefully check the condition of the repaired area.	
24	Masking removal	Remove the masking tape applied in Process No. 11 and 13.	
25	Parts installation	Install the parts on bumper in reverse order of removal.	
26	Bumper installation	Install the bumper.	

## 6. Rear Bumper

### A: REMOVAL

#### 1. WAGON MODEL

- 1) Disconnect the ground cable from battery.
- 2) Remove the bolt inside wheel house (both sides), and the clips on lower side of bumper.

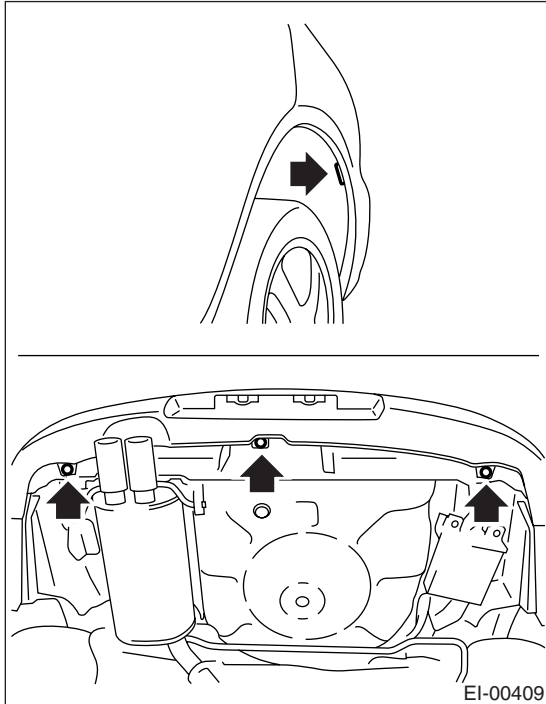

- 3) Remove the rear combination light assembly. <Ref. to LI-22, REMOVAL, Rear Combination Light Assembly.>

- 4) Remove the screw and two clips (both sides).

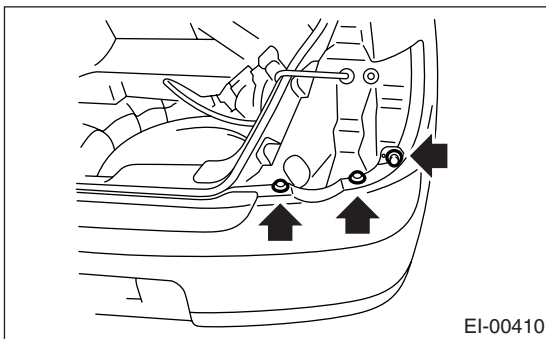

- 5) Remove the floor box.
- 6) Remove the rear skirt trim.

- 7) Turn over the rear quarter lower trims on both sides, and then loosen the four nuts.

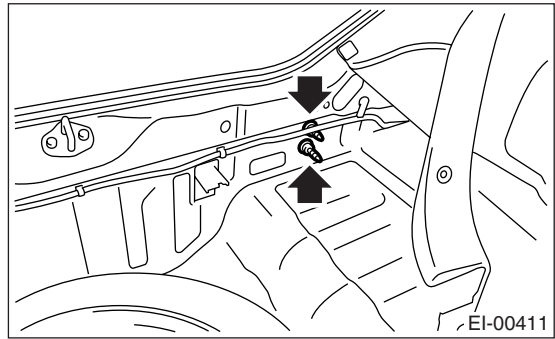

- 8) Disconnect the license plate light connector, and then remove the rear bumper.
- 9) Remove the E/A FORM from bumper beam.

**CAUTION:**  
E/A FORM may easily break. Do not apply excessive force to it during removal.

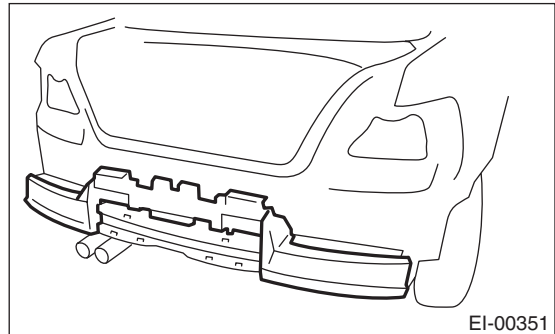

- 10) Remove the bolt.

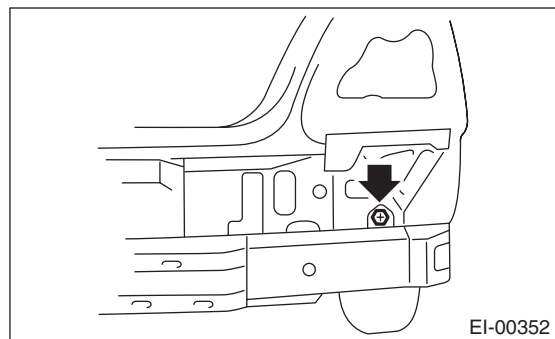

- 11) Remove the three bolts, then remove the bumper beam.

# Rear Bumper

## EXTERIOR/INTERIOR TRIM

### NOTE:

In the case of right side, remove the canister first. Loosen the bolt, and then remove the bumper beam.

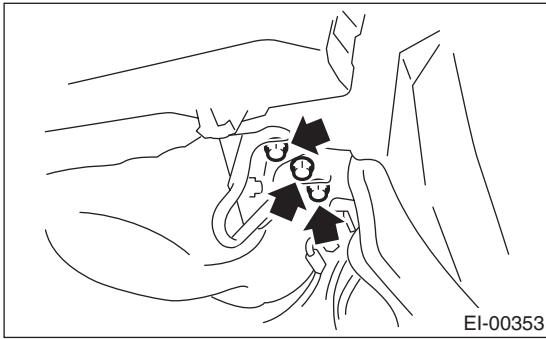

12) Remove the five clips, and then remove the bumper upper beam.

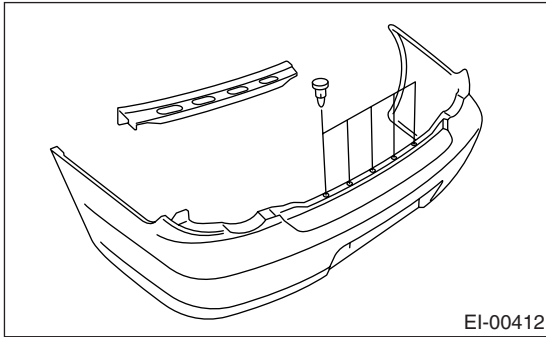

13) Remove the license plate light.

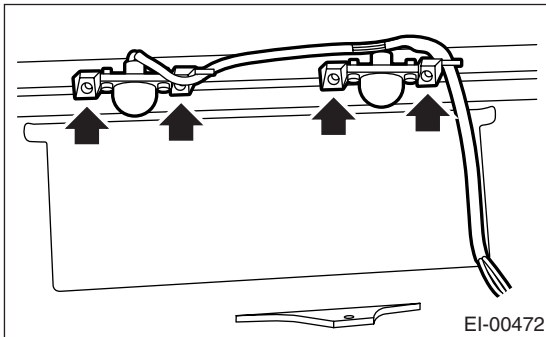

14) Remove the six clips, and then remove the bumper side cover.

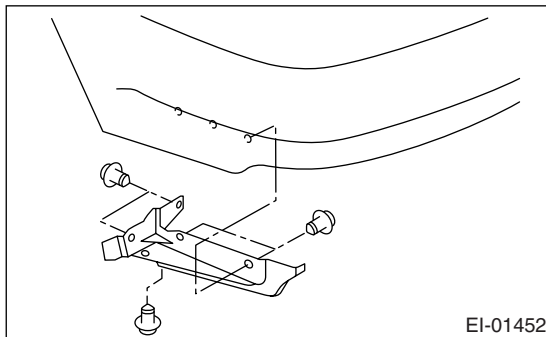

15) Remove the upper bracket from body.

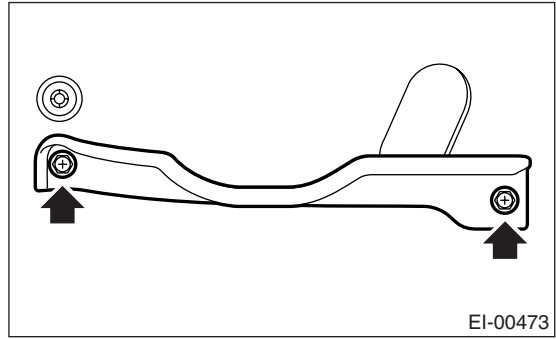

## 2. SEDAN MODEL

Refer to description about removal of rear bumper of wagon model. <Ref. to EI-31, WAGON MODEL, REMOVAL, Rear Bumper.>

## B: INSTALLATION

### 1. WAGON MODEL

Install in the reverse order of removal.

#### Tightening torque:

Refer to **COMPONENT** in *General Description*.

<Ref. to EI-5, REAR BUMPER, COMPONENT, General Description.>

### 2. SEDAN MODEL

Install in the reverse order of removal.

#### Tightening torque:

Refer to **COMPONENT** in *General Description*.

<Ref. to EI-5, REAR BUMPER, COMPONENT, General Description.>

## C: REPAIR

Refer to description about repair of front bumper. <Ref. to EI-24, REMOVAL, Front Bumper.>



## 7. Mud Guard

### A: REMOVAL

- 1) Lift-up the vehicle.
- 2) Remove the screws and clips to remove mud guard.

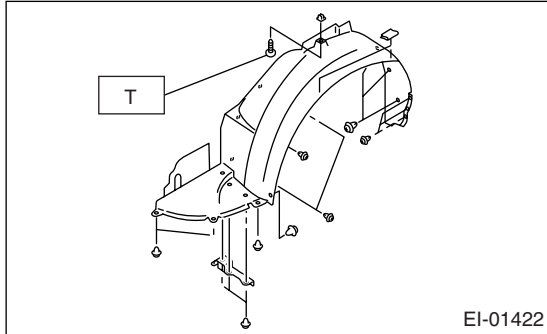

### B: INSTALLATION

Insert the hook into body, and tighten it with screw and clip.

**Tightening torque:**

***T: 4.5 N·m (0.46 kgf-m, 3.3 ft-lb)***

## 8. Cowl Panel

### A: REMOVAL

- 1) Open the front hood.
- 2) Remove the wiper arm. <Ref. to WW-13, REMOVAL, Front Wiper Arm.>
- 3) Remove the front panel seal.

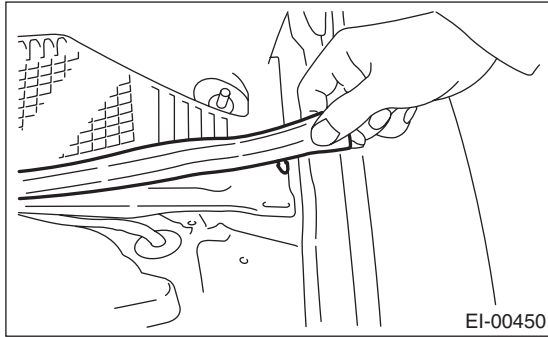

- 4) Disengage the clips (A) to remove the cowl panel.

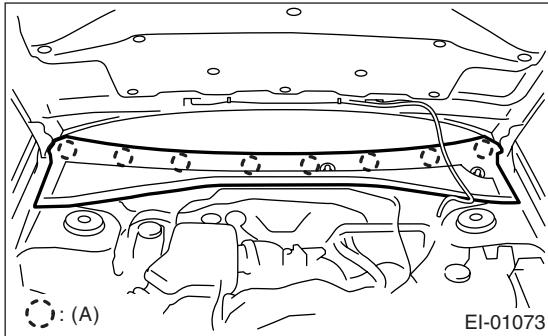

(A) Clip

### B: INSTALLATION

Install in the reverse order of removal.

## 9. Roof Spoiler

### A: REMOVAL

- 1) Remove the bolt cap, and then remove the two bolts.
- 2) Remove the roof spoiler.

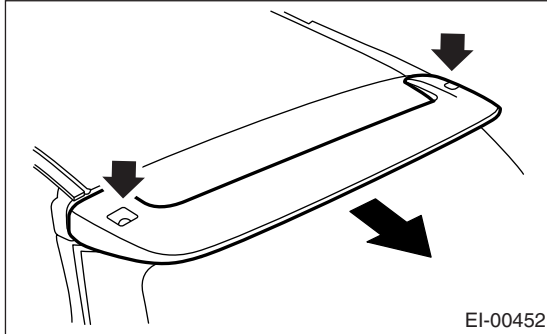

### B: INSTALLATION

Install in the reverse order of removal.

#### ***Tightening torque:***

***7.5 N·m (0.76 kgf-m, 5.5 ft-lb)***

## 10.Rear Spoiler

### A: REMOVAL

- 1) Disconnect the ground cable from battery.
- 2) Open the trunk lid.
- 3) Remove the electrical connector (A) of high mount stop light.

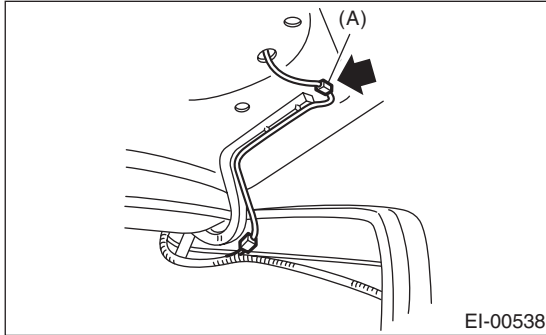

- 4) Loosen the mounting nut of rear spoiler to remove rear spoiler.

### CAUTION:

- When removing the nut, do not drop it into trunk lid.
- Pay attention to avoid damage during removal or installation.

Small-sized rear spoiler: Four tightening positions, two clips

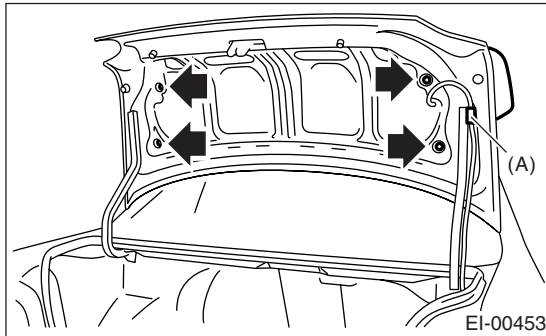

(A) Connector

Large-sized rear spoiler: Twelve tightening positions, four clips

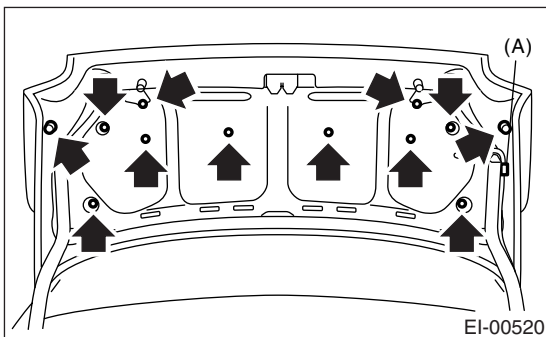

(A) Connector

### B: INSTALLATION

- 1) Install in the reverse order of removal.
- 2) Clean the mounting surfaces of trunk lid and spoiler before installation.

### Tightening torque:

**7.5 N·m (0.76 kgf-m, 5.5 ft-lb)**

## 11.Side Sill Spoiler

### A: REMOVAL

1) Remove the clips (one on front fender arch, six on bottom of side sill spoiler), then remove the side spoiler.

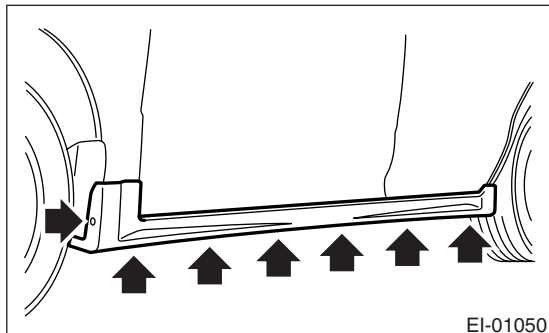

2) Remove the one rivet clip (A) and two clips, and then remove the end cover. (Except STI model)

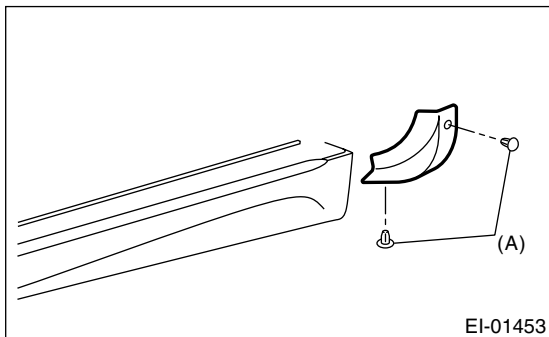

3) Remove the rear air flap plate from side sill spoiler.

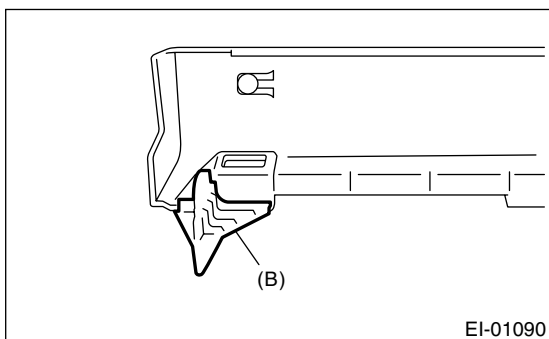

### B: INSTALLATION

Install in the reverse order of removal.

## 12.Side Protector

### A: REMOVAL

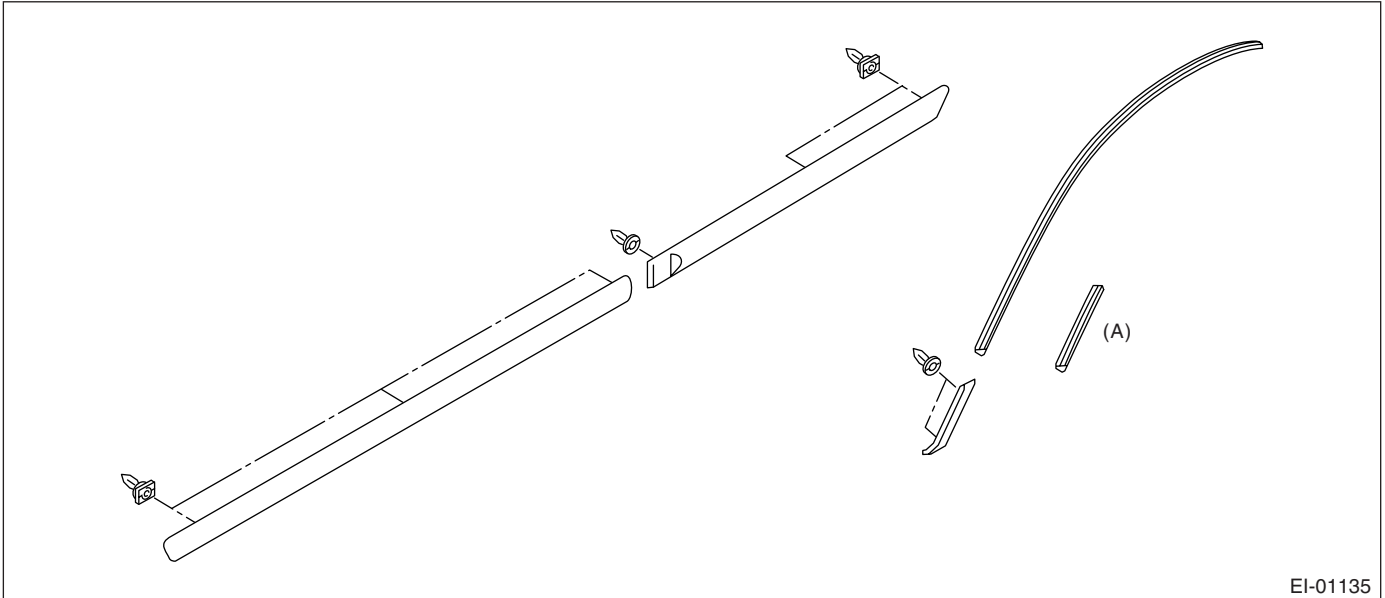

EI-01135

(A) STI model

1) Slide in a thin thread (A) of 0.8 mm (0.031 in) diameter or less (fishing line etc.) between body and protector, and then remove the protector detaching double-sided tape. Remove the protector using clip remover.

- If the double-sided tape remains thick on surface due to interfacial peeling, apply the solvent after slicing off the double-sided tape using a cutter.

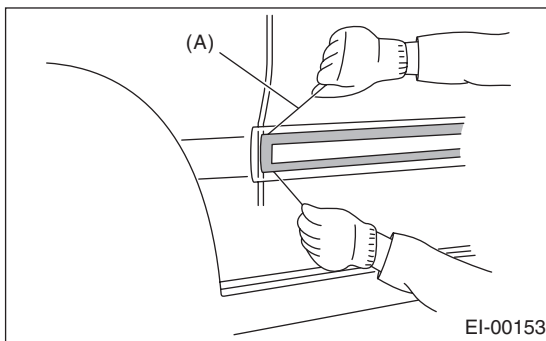

EI-00153

#### NOTE:

- To optimize the effect of solvent, slide the thread along the body without removing the double-sided tape on surface of body and spoiler.
- If it is difficult to detach the double-sided tape, warm up to approx. 40°C (104°F).

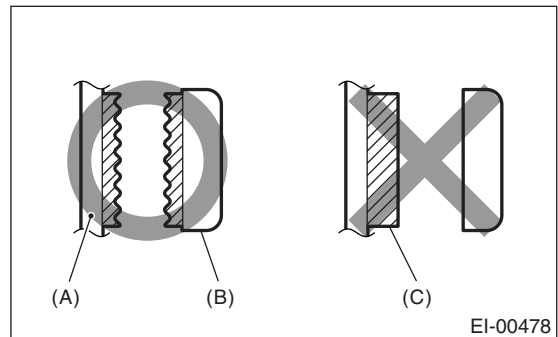

EI-00478

- (A) Panel  
 (B) Spoiler  
 (C) Double-sided tape

- 2) Adhere the masking tape around the double-sided tape remaining on surface of body and spoiler.
- 3) Apply the solvent uniformly on double-sided tape using a brush.

#### CAUTION:

- Do not use the solvent to body which is repaired with lacquer paint.
- Wipe off immediately when the solvent is touched on surface of body and spoiler.

#### Solvent:

**3M 8907 or equivalent**

4) Cover the area where solvent is applied using plastic wrap (A), and then heat the double-sided tape for 5 to 10 minutes in 40 to 60°C (104 to 140°F) using a heat lamp (B).

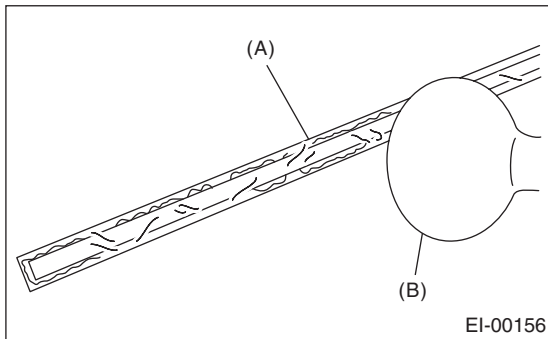
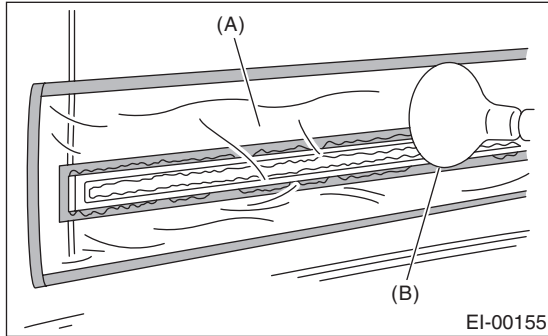

**Primer:**  
**3M K-500 or equivalent**

**Double-sided tape:**  
**3M 5531-5 or equivalent**

2) Heat the adhering part using a heat lamp.

Body side: 40 — 60°C (104 — 140°F)

Protector side: 20 — 30°C (68 — 86°F)

3) Detach the double-sided tape backing sheet, align to clip position, and then adhere to body using care to avoid air entering.

**CAUTION:**  
**To keep the adhesion, do not wash the vehicle within 24 hours.**

**CAUTION:**  
**Do not heat the double-sided tape until the surface becomes white and excessively dried.**

5) Remove the double-sided tape using a plastic spatula.

6) After completely removing the double-sided tape, detach the masking tape and clean the surface using a cotton cloth waste damped with white gasoline.

## B: INSTALLATION

1) Apply the primer to protector surface where the double-sided tape is adhered, and then adhere the double-sided tape as shown in the figure.

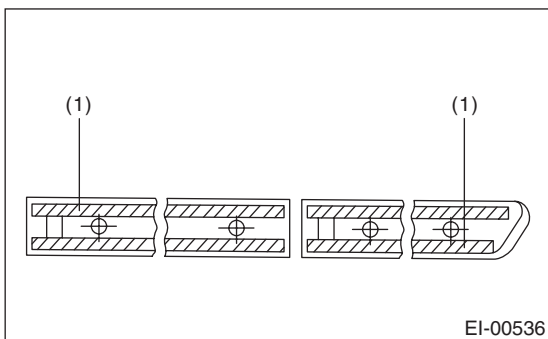

(1) Double-sided tape; thickness: 1.2 mm (0.047 in), width: 5 mm (0.197 in)

## 13. Arch Cover

### A: REMOVAL

#### CAUTION:

Never remove the arch cover unless necessary.  
Otherwise the arch cover may be damaged.

- 1) Lift-up the vehicle.
- 2) Remove the bolt inside the wheel house.

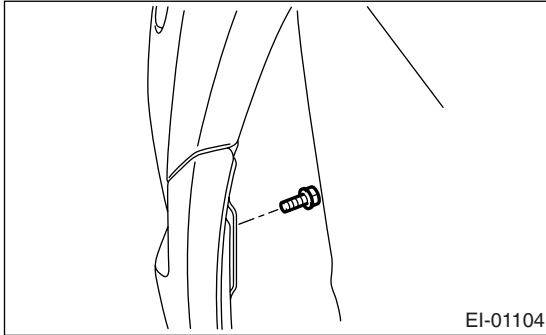

- 3) Remove the two hook of arch cover by pulling the rear bumper outward.

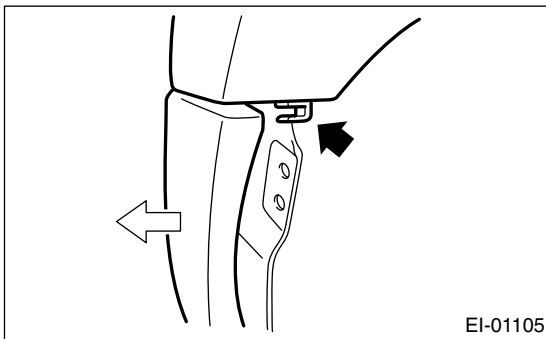

- 4) Remove the arch cover using clip remover.

### B: INSTALLATION

Install in the reverse order of removal.



## 14. Front Door Trim

### A: REMOVAL

**CAUTION:**

**Do not apply excessive force to the clip. Otherwise the clip may be broken.**

- 1) Disconnect the ground cable from battery.
- 2) Remove the gusset cover.
- 3) Insert the flat tip screw driver into A part of inner remote cover, and then remove the lower hook with turning screw driver.

Remove the upper hook with pulling inner remote cover, and then remove the inner remote cover.

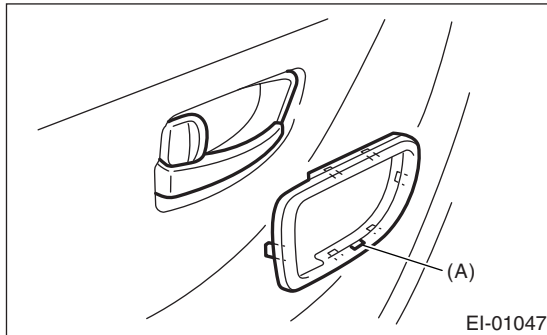

- 4) Remove the power window control switch. <Ref. to GW-9, REMOVAL, Power Window Control Switch.>
- 5) Remove the clips of trim panel using clip remover to remove trim panel.

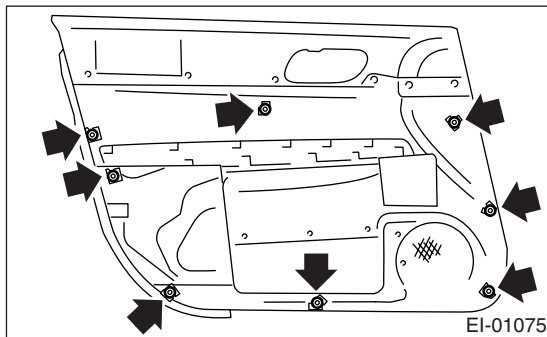

### B: INSTALLATION

Install in the reverse order of removal.

## 15.Rear Door Trim

### A: REMOVAL

#### CAUTION:

**Do not apply excessive force to the clip. Otherwise the clip may be broken.**

- 1) Disconnect the ground cable from battery.
- 2) Insert the flat tip screw driver into A part of inner remote cover, and then remove the lower hook with turning screw driver.

Remove the upper hook with pulling inner remote cover, and then remove the inner remote cover.

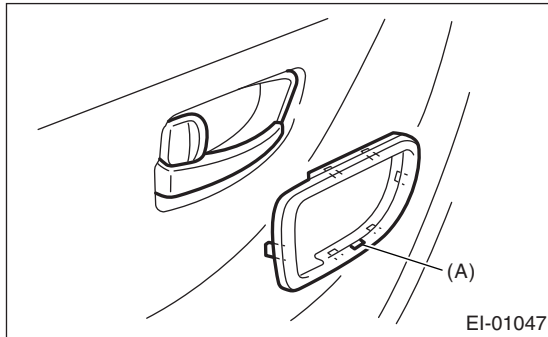

- 3) Remove the power window control switch. <Ref. to GW-9, REMOVAL, Power Window Control Switch.>

- 4) Remove the clips of trim panel using clip remover to remove trim panel.

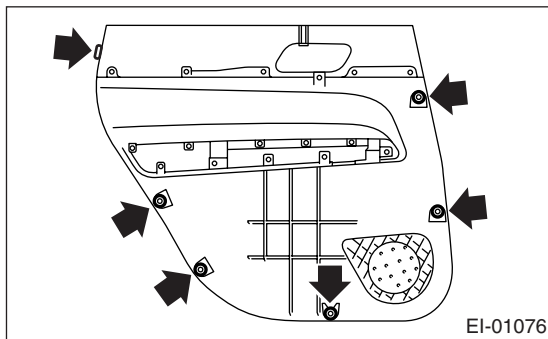

### B: INSTALLATION

Install in the reverse order of removal.

## 16. Glove Box

### A: REMOVAL

- 1) Open the glove box.
- 2) Remove the screws to remove glove box.

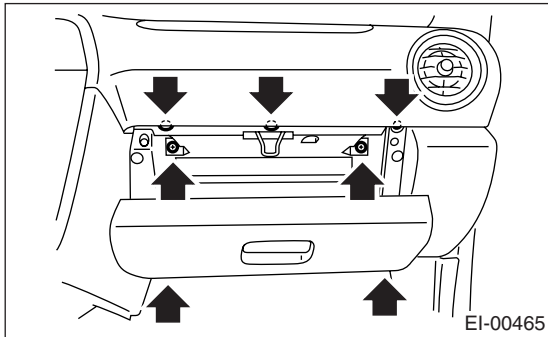

### B: INSTALLATION

Install in the reverse order of removal.

## 17. Roof Rail

### A: REMOVAL

- 1) Remove the roof trim. <Ref. to EI-55, REMOVAL, Roof Trim.>
- 2) Remove the four mounting nuts, and then detach the roof rail carefully.

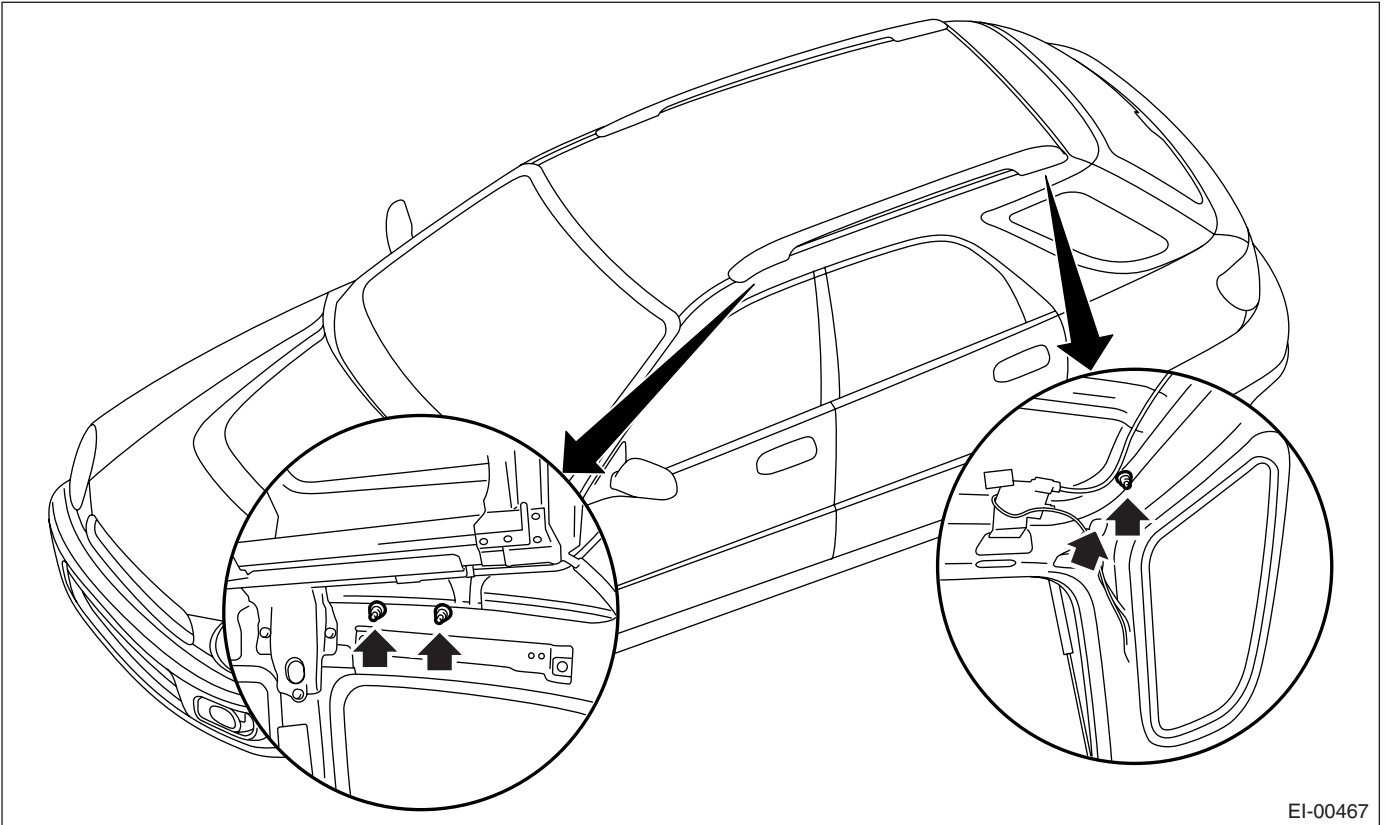

EI-00467

### B: INSTALLATION

Install in the reverse order of removal.

#### CAUTION:

Be careful not to scratch the body panels with roof rail stud bolts when removing and installing them.

#### Tightening torque:

*7.4 N·m (0.75 kgf·m, 5.46 ft·lb)*

## 18. Roof Molding

### A: REMOVAL

1) Turn over the edge of roof molding, and then remove it by sliding the internal clip using a flat tip screwdriver.

RH: Slide the molding toward the rear side of vehicle.

LH: Slide the molding toward the front side of vehicle.

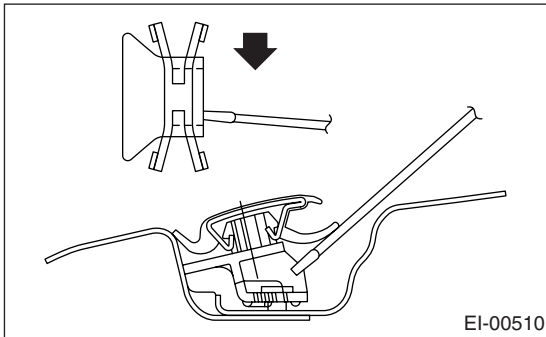
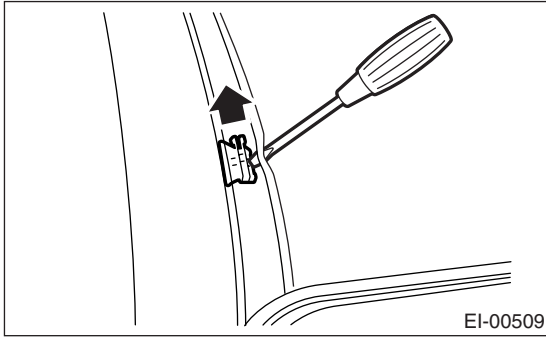

Sedan model: six clips

Wagon model (without roof rail): eight clips

Wagon model (with roof rail): seven clips

2) For sedan model, remove four clips of rear pillar. Turn over the roof molding on rear glass side, insert a board of about 0.5 mm (0.020 in) thickness into clearance between roof molding and glass, and then remove the claw of internal clip.

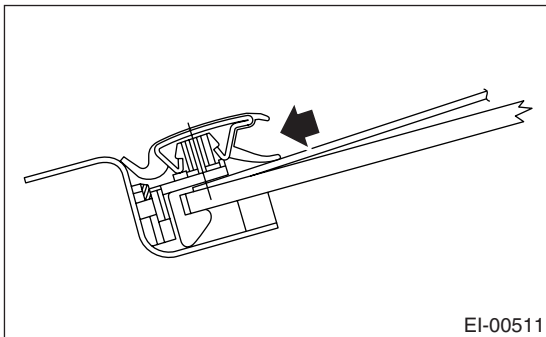

### B: INSTALLATION

1) Remove the clip of roof and rear pillar (sedan model) from roof molding, and then install it to body side.

#### CAUTION:

**Make sure to replace the clips broken when removing the roof molding with new ones.**

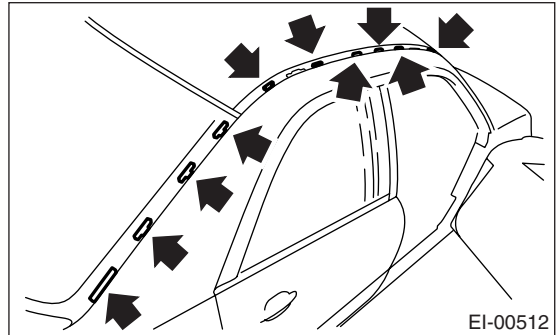

2) Put the front edge of roof molding onto front window molding, and insert the front locating pin into body side cap.

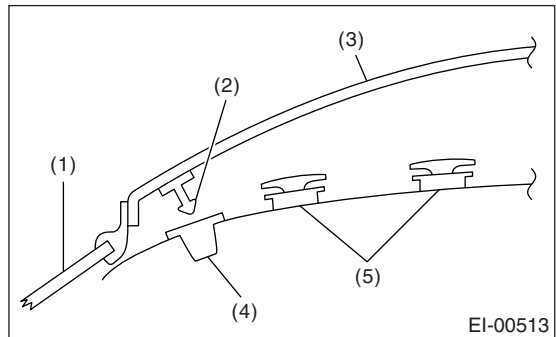

(1) Front window

(2) Locating pin

(3) Roof molding

(4) Cap

(5) Clip (roof)

3) Install the roof molding to body, by pushing the roof molding from above being careful not to deform it.

# Console Box

EXTERIOR/INTERIOR TRIM

## 19. Console Box

### A: REMOVAL

- 1) Disconnect the ground cable from battery.
- 2) Remove the console front panel.

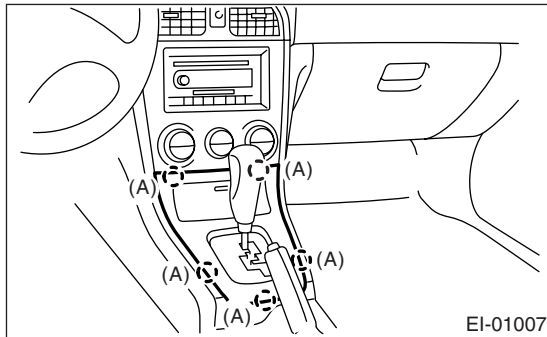

(A) Hook pawl

- 3) Remove the shift knob (MT model).
- 4) Remove the screws to remove console cover.

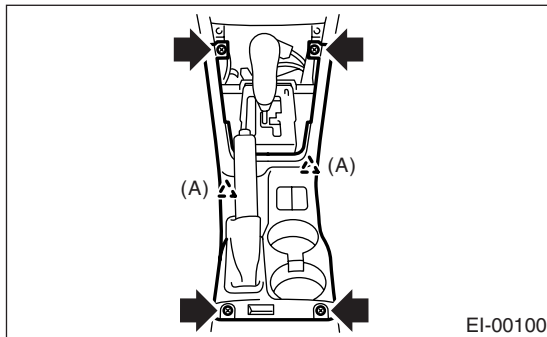

(A) Clip

- 5) Remove the screws.

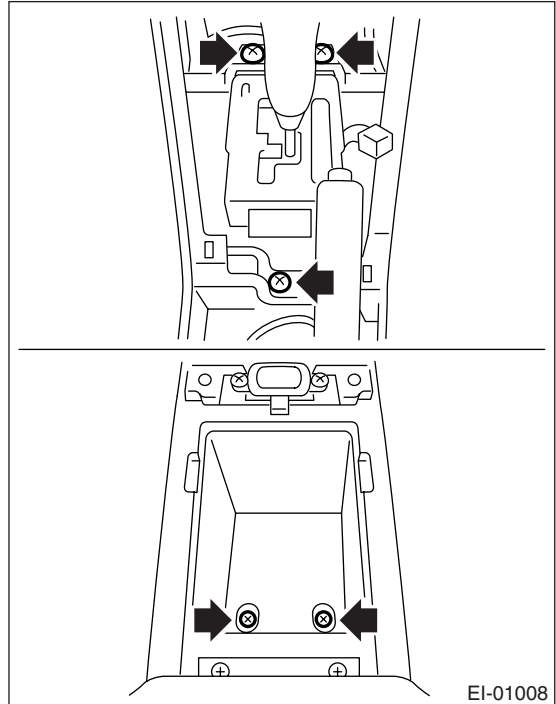

- 6) Remove the hook pawl of console side panel to remove console box.

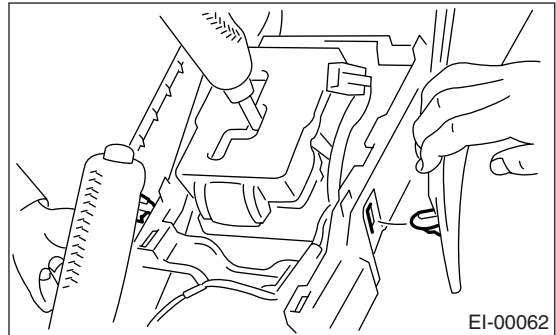

### B: INSTALLATION

Install in the reverse order of removal.

## 20. Instrument Panel Assembly

### A: REMOVAL

#### CAUTION:

- All airbag system connectors are colored yellow. Do not use electrical equipment on these circuits.
- Be careful not to damage the airbag system harness when servicing the instrument panel.

- 1) Disconnect the ground cable from battery.
- 2) Loosen the screws, remove the clip (A), disconnect the connectors, and then remove the instrument panel lower cover.

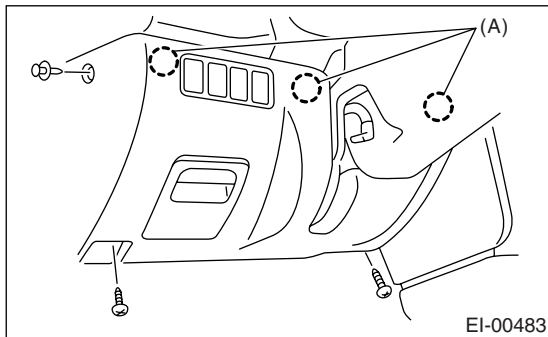

- 3) Remove the console front panel and console cover. <Ref. to EI-46, REMOVAL, Console Box.>
- 4) Remove the clip (A), and then remove the center console panel.

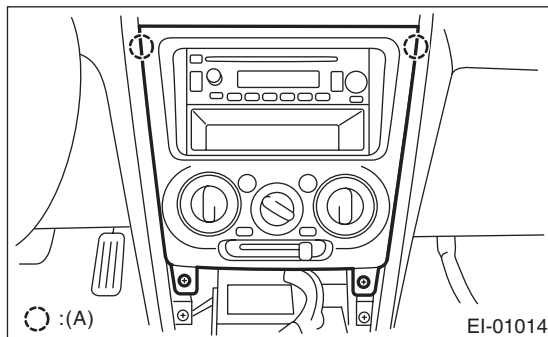

- 5) Remove the glove box. <Ref. to EI-43, REMOVAL, Glove Box.>
- 6) Loosen the screws, and then remove the console side panel.

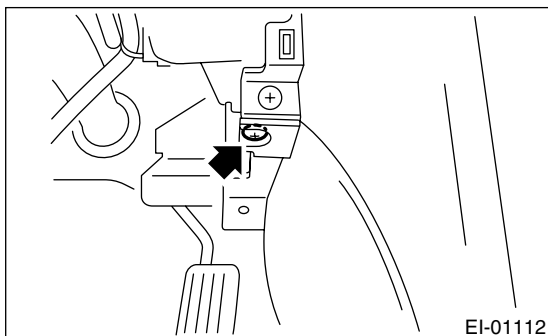

- 7) Remove the passenger's airbag module. <Ref. to AB-15, Passenger's Airbag Module.>
- 8) Loosen the four screws and two nuts, and then remove the lower console panel.

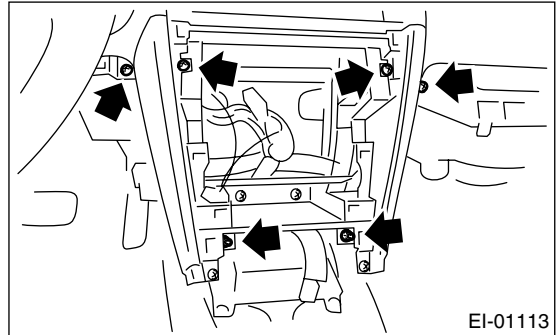

- 9) Remove the hook, and then remove the defroster panel.

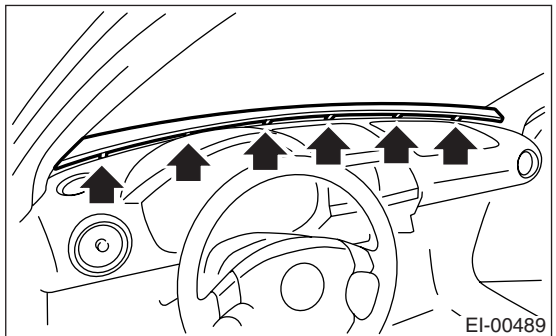

- 10) Remove the front pillar upper trim. <Ref. to EI-50, REMOVAL, Upper Inner Trim.>
- 11) Disconnect the two connectors, and then loosen the nuts.

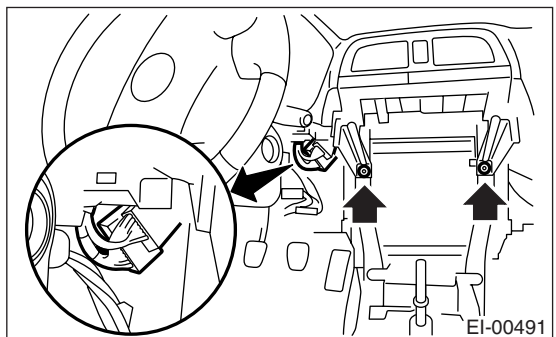

# Instrument Panel Assembly

EXTERIOR/INTERIOR TRIM

12) Remove the instrument panel installation bolts.

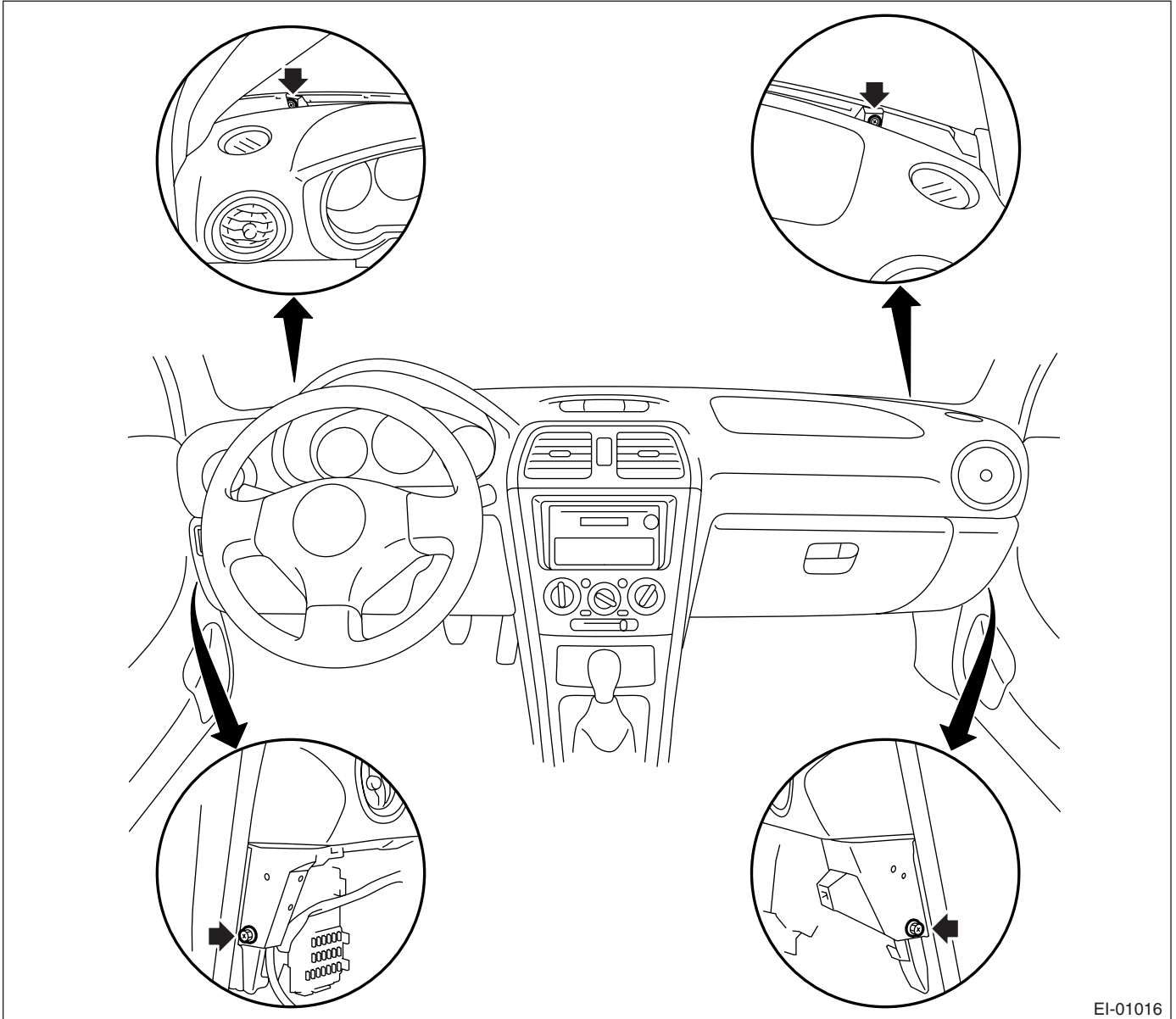

EI-01016



13) Make sure that all the harnesses are disconnected, and then remove the instrument panel from vehicle.

**NOTE:**

- Put alignment marks as necessary, in order to facilitate the reassembly.
- When storing the removed instrument panel, place it standing up on the floor.

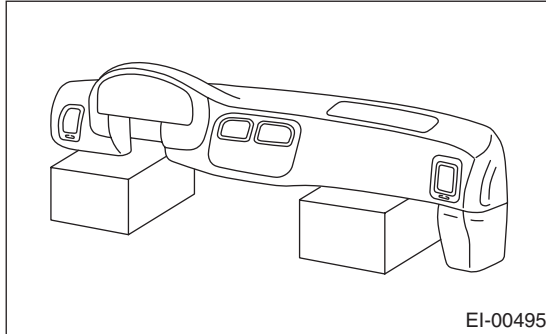

## B: INSTALLATION

**CAUTION:**

- Be careful not to snag the harness.
- Carry out installation checking that the harness is connected correctly.
- When setting the instrument panel into vehicle, do not damage trim panels.

1) Install in the reverse order of removal.

**NOTE:**

When installing the instrument panel into position, push the hook into grommet (A) on the body panel. After tightening the bolts, recheck the installation.

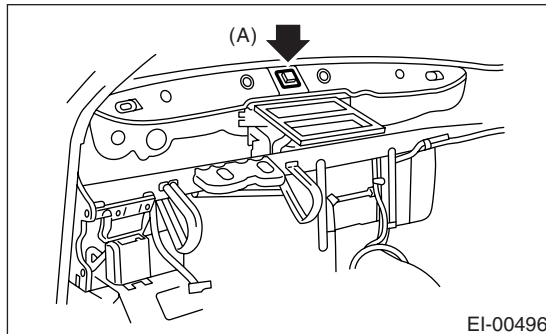

## 21.Upper Inner Trim

### A: REMOVAL

- 1) Remove the lower inner trim. <Ref. to EI-51, REMOVAL, Lower Inner Trim.>
- 2) Remove the front molding (A).
- 3) Remove the front pillar upper trim (B).
- 4) Detach the front seat belt shoulder anchor, and then remove the center pillar upper trim (C).

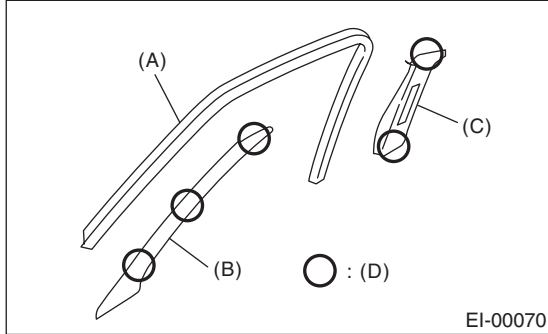

(D) Clip

### B: INSTALLATION

Install in the reverse order of removal.

#### CAUTION:

**Be sure to securely hook the pawls of inner trim panel to body flange.**

#### NOTE:

When installing the center pillar upper trim and front pillar upper trim, be sure to set the front molding as shown in the figure.

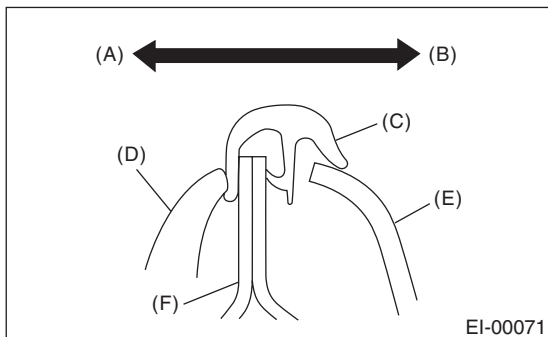

- (A) Outside
- (B) Inside
- (C) Molding
- (D) Weather strip
- (E) Trim
- (F) Body

## 22. Lower Inner Trim

### A: REMOVAL

- 1) Remove the side sill front cover (A).
- 2) Remove the rear seat cushion, and then remove side sill rear cover (B). <Ref. to SE-13, REMOVAL, Rear Seat.>
- 3) Remove the center pillar lower trim (C).

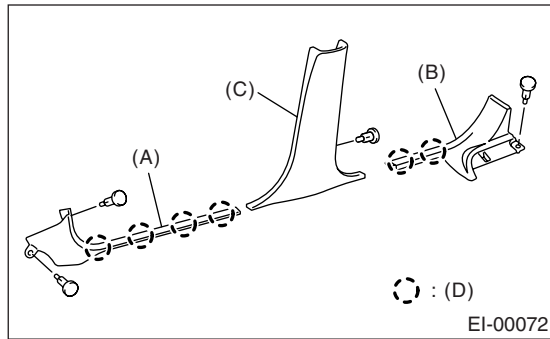

(D) Clip

### B: INSTALLATION

Install in the reverse order of removal.

#### CAUTION:

**Be sure to securely hook pawls of inner trim panel to body flange.**

# Rear Quarter Trim

EXTERIOR/INTERIOR TRIM

## 23. Rear Quarter Trim

### A: REMOVAL

#### 1. SEDAN MODEL

- 1) Remove the rear seat. <Ref. to SE-13, REMOVAL, Rear Seat.>
- 2) Remove the side sill rear cover. <Ref. to EI-51, REMOVAL, Lower Inner Trim.>
- 3) Remove the rear pillar lower cover (A).
- 4) Remove the seat belt lower anchor bolt, and then remove the rear pillar upper trim (B).

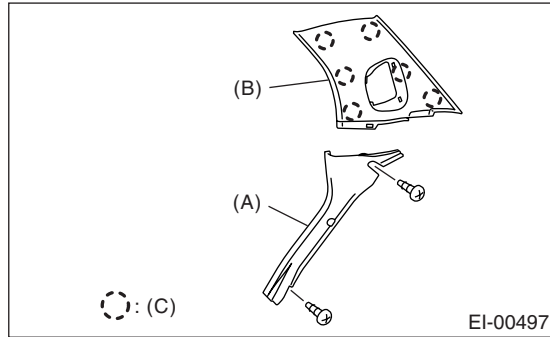

(C) Clip

#### 2. WAGON MODEL

- 1) Remove the rear seat. <Ref. to SE-13, REMOVAL, Rear Seat.>
- 2) Remove the side sill rear cover.
- 3) Remove the rear rail trim (A).
- 4) Loosen the screws and clips to remove the rear quarter upper trim (B).
- 5) Remove the rear skirt trim (C).

- 6) Remove the bolts and clips to remove the rear quarter lower trim (D).

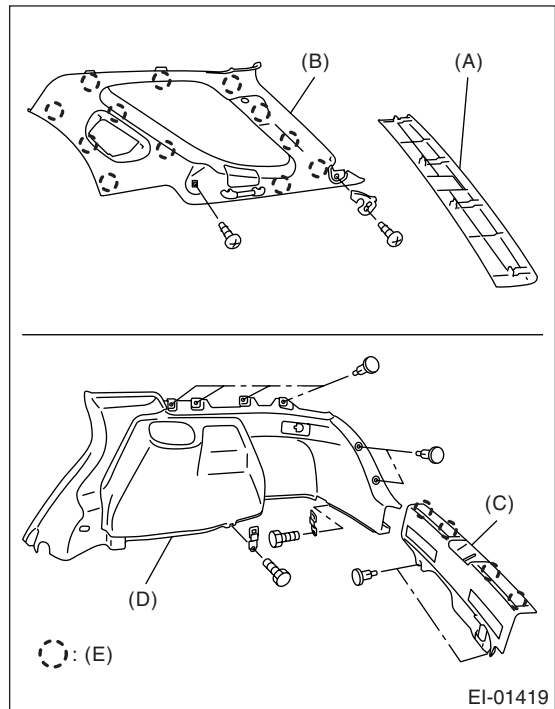

(E) Clip

- 7) Remove the nut, and remove the luggage compartment side rail.

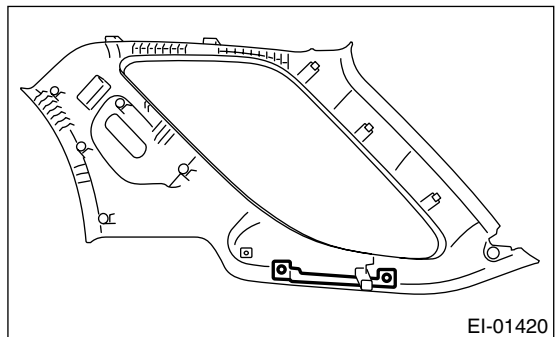

### B: INSTALLATION

Install in the reverse order of removal.

#### CAUTION:

Be sure to securely hook the pawls of inner trim panel to body flange.

**NOTE:**

When installing the rear quarter upper trim, be sure to set the rear molding as shown in the figure.

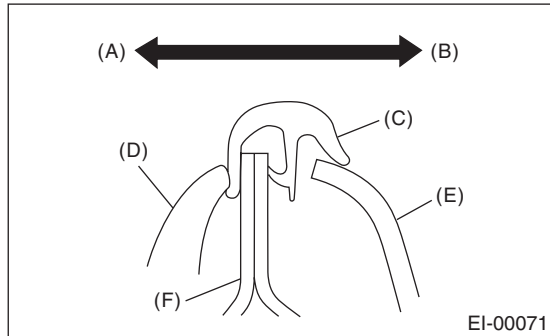

- (A) Outside
- (B) Inside
- (C) Molding
- (D) Weather strip
- (E) Trim
- (F) Body

## 24.Sun Visor

### A: REMOVAL

Remove the mounting screws, and then detach the sun visor (A) and hook (B).

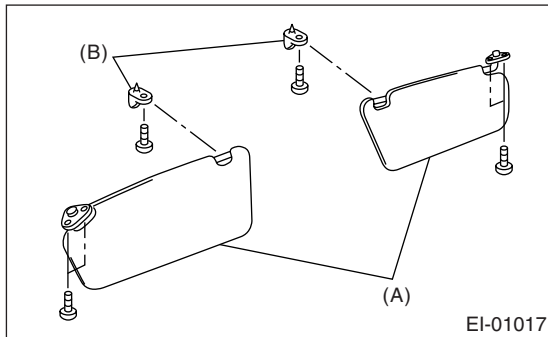

### B: INSTALLATION

Install in the reverse order of removal.

## 25. Roof Trim

### A: REMOVAL

#### CAUTION:

When removing the clip, use great care not to damage the roof trim.

#### 1. SEDAN MODEL

- 1) Disconnect the ground cable from battery.
- 2) Remove the sunroof switch. (Model with sunroof) <Ref. to SR-9, REMOVAL, Sunroof Switch.>
- 3) Remove the spot map light. <Ref. to LI-28, REMOVAL, Spot Map Light.>
- 4) Remove the room light. <Ref. to LI-29, REMOVAL, Room Light.>
- 5) Remove the sun visor and hook on right or left side, or on both sides. <Ref. to EI-54, REMOVAL, Sun Visor.>
- 6) In the case of models with sunroof, remove the sunroof weather strip.

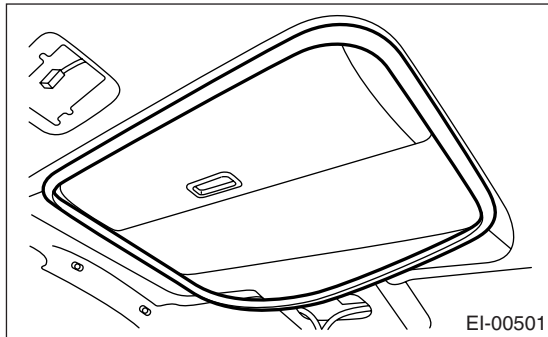

- 7) Remove the assist-grips (A).

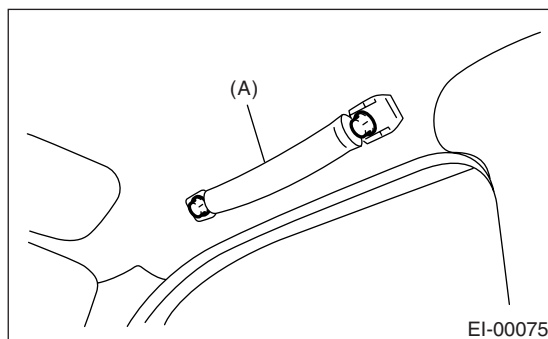

- 8) Remove the upper inner trim. <Ref. to EI-50, REMOVAL, Upper Inner Trim.>
- 9) Remove the quarter upper trim. <Ref. to EI-52, SEDAN MODEL, REMOVAL, Rear Quarter Trim.>

- 10) Remove the clips, and then remove the roof trim.

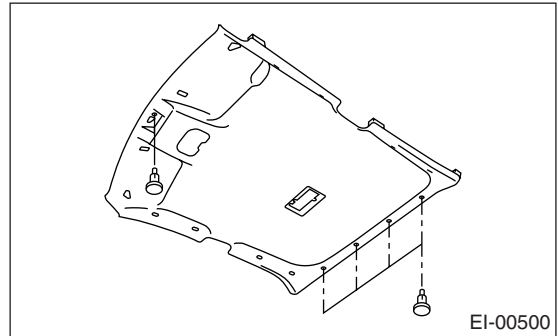

#### 2. WAGON MODEL

- 1) Disconnect the ground cable from battery.
- 2) Remove the sunroof switch. (Model with sunroof) <Ref. to SR-9, REMOVAL, Sunroof Switch.>
- 3) Remove the room light. <Ref. to LI-29, REMOVAL, Room Light.>
- 4) Remove the sun visor and hook or both sides. <Ref. to EI-54, REMOVAL, Sun Visor.>
- 5) In case of models with sunroof, remove the sunroof weather strip.

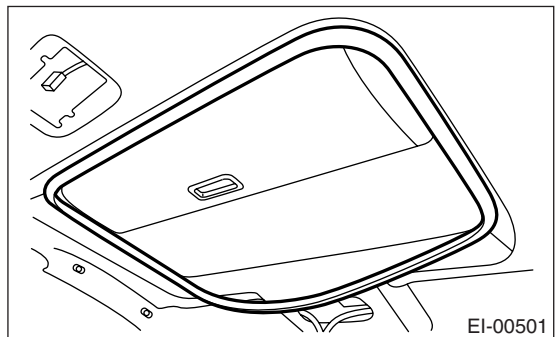

- 6) Remove the assist-grips (A).

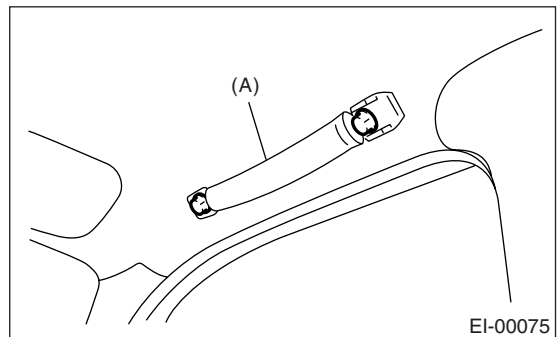

- 7) Remove the upper inner trim. <Ref. to EI-50, REMOVAL, Upper Inner Trim.>
- 8) Remove the rear quarter upper trim shown in the figure.
- 9) Remove the rear rail trim (A).

# Roof Trim

## EXTERIOR/INTERIOR TRIM

---

10) Remove the rear quarter upper trim (B) of both sides.

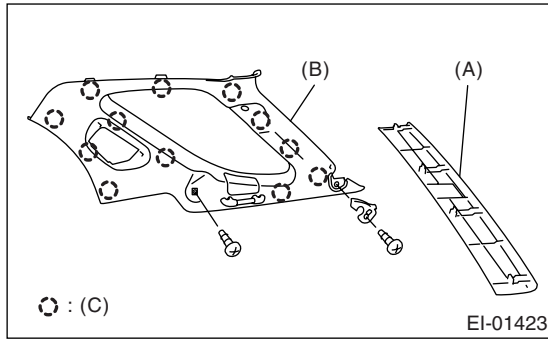

(C) Clip

11) Remove the clips, and then remove the roof trim.

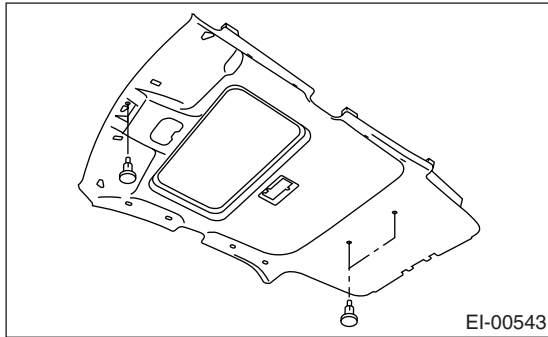

## **B: INSTALLATION**

Install in the reverse order of removal.



## 26.Rear Gate Trim

### A: REMOVAL

#### CAUTION:

Be careful not to damage the clips or their holes.

Remove the clips, and then detach the rear gate trim.

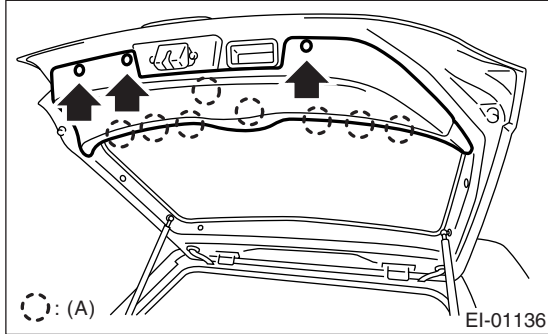

(A) Clip

### B: INSTALLATION

Install in the reverse order of removal.

## 27.Rear Shelf Trim

### A: REMOVAL

- 1) Disconnect the ground cable from battery.
- 2) Remove the high-mounted stop light.

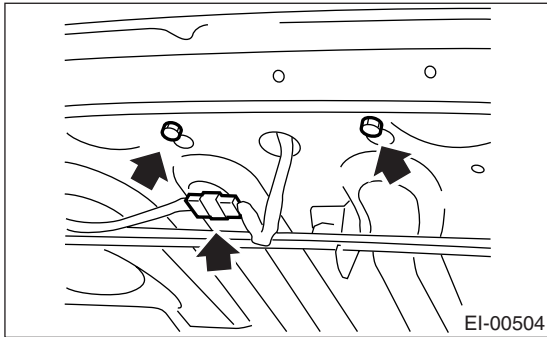

- 3) Remove the rear quarter upper trim. <Ref. to EI-52, REMOVAL, Rear Quarter Trim.>
- 4) Remove the seat belt center anchor lower bolt.
- 5) Remove the rear shelf trim.

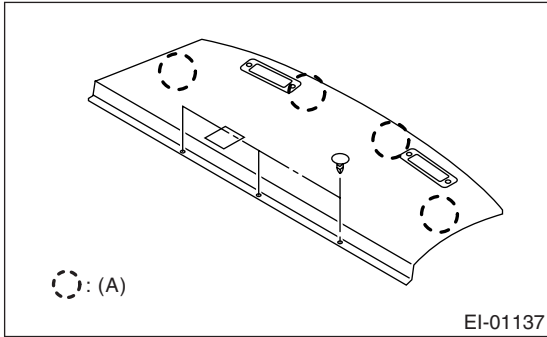

(A) Clip

### B: INSTALLATION

Install in the reverse order of removal.

## 28.Trunk Room Trim

### A: REMOVAL

- 1) Remove the rear seat backrest. <Ref. to SE-13, SEDAN MODEL, REMOVAL, Rear Seat.>
- 2) Remove the trunk room mat.

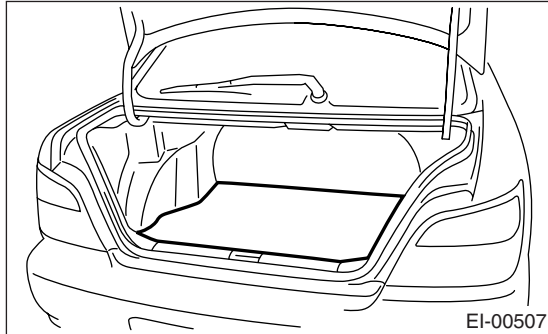

- 3) Remove the clip (A).
- 4) Remove the clips, and then detach the trunk rear trim (B).
- 5) Remove the clips to remove trunk side trim (C).

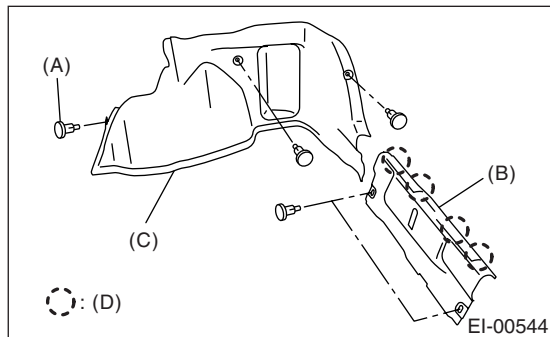

(D) Clip

### B: INSTALLATION

Install in the reverse order of removal.

## 29. Floor Mat

### A: REMOVAL

- 1) Remove the front seats. <Ref. to SE-7, REMOVAL, Front Seat.>
- 2) Remove the rear seat cushion. <Ref. to SE-13, REMOVAL, Rear Seat.>
- 3) Remove the console box. <Ref. to EI-46, Console Box.>
- 4) Remove the side sill front cover, side sill rear cover and center pillar lower trim. <Ref. to EI-51, REMOVAL, Lower Inner Trim.>
- 5) Remove the foot rest.
- 6) Remove the clips from floor mat.
- 7) Remove the mat hook.
- 8) Remove the mat from toe board area.
- 9) Remove the mat from rear heater duct.
- 10) Roll the mat, and then take it out of opened rear door.

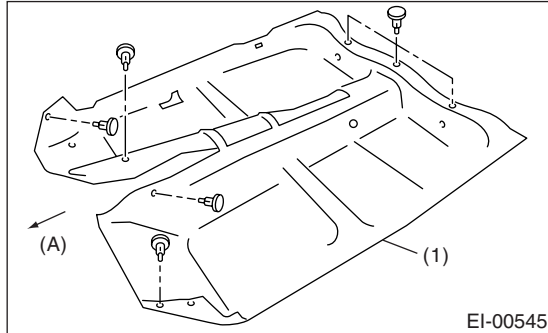

- (A) Front  
(1) Floor mat

### B: INSTALLATION

Install in the reverse order of removal.

#### NOTE:

- Secure the mat firmly with hook and Velcro tape.
- Insert the mat edge firmly into the groove of side sill cover.

## 30.Luggage Floor Mat

### A: REMOVAL

Remove the clips, and then detach the rear floor mats.

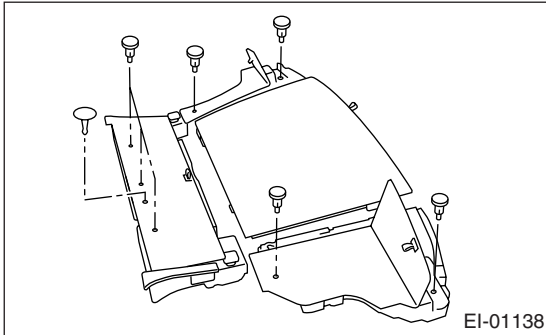

### B: INSTALLATION

Install in the reverse order of removal.

# Heat Shield Cover

EXTERIOR/INTERIOR TRIM

## 31.Heat Shield Cover

### A: REMOVAL

#### 1. CENTER HEAT SHIELD COVER

1) Remove the rear exhaust pipe and muffler.

- Non-turbo model

<Ref. to EX(H4SO)-7, REMOVAL, Rear Exhaust Pipe.> <Ref. to EX(H4SO)-8, REMOVAL, Muffler.>

- Turbo model and STI model

<Ref. to EX(H4DOTC)-15, REMOVAL, Rear Exhaust Pipe.> <Ref. to EX(H4DOTC)-16, REMOVAL, Muffler.>

2) Remove the propeller shaft. <Ref. to DS-16, REMOVAL, Propeller Shaft.>

3) Remove the four bolts to remove center heat shield cover. (Except STI model)

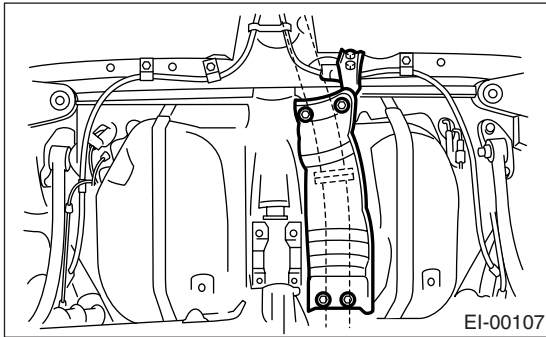

4) Remove the four nuts and two clips to remove center heat shield cover. (STI model)

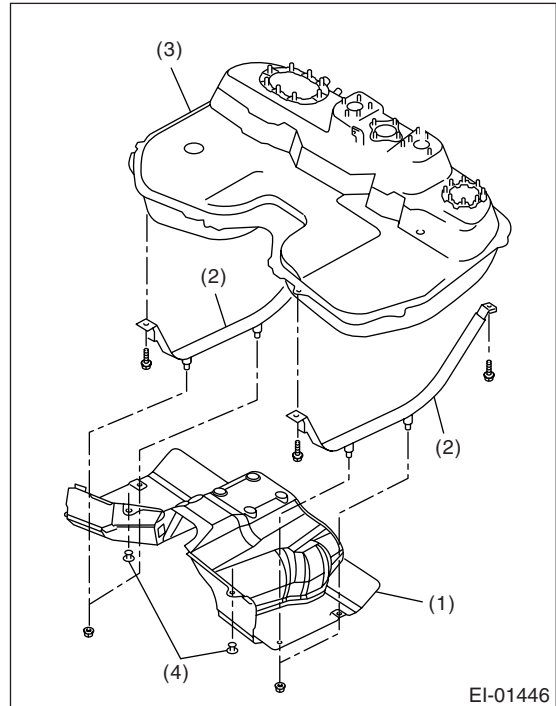

- (1) Center heat shield cover
- (2) Fuel tank band
- (3) Fuel tank
- (4) Clips

#### 2. REAR HEAT SHIELD COVER

1) Remove the muffler. <Ref. to EX(H4SO)-8, REMOVAL, Muffler.> <Ref. to EX(H4DOTC)-16, REMOVAL, Muffler.>

2) Remove the four bolts to remove rear heat shield cover.

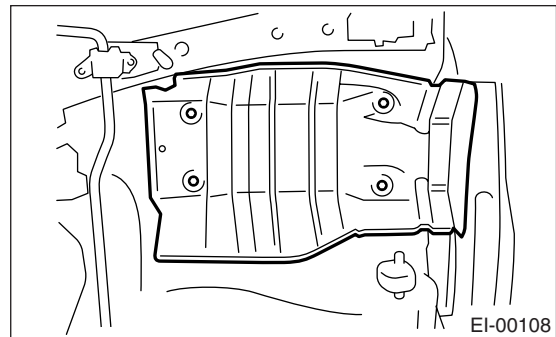

### B: INSTALLATION

Install in the reverse order of removal.

## 32. Diffuser

### A: REMOVAL

- 1) Lift-up the vehicle.
- 2) Loosen the five bolts to remove rear diffuser.

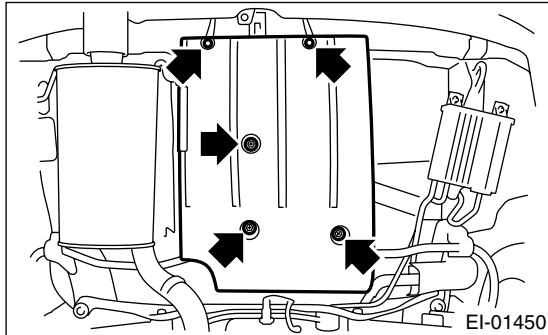

- 3) Remove the two bolts, and remove the diffuser bracket.

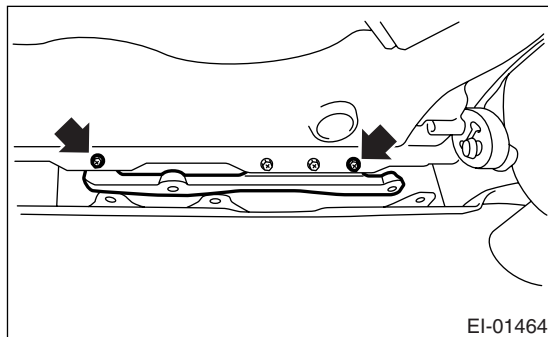

### B: INSTALLATION

Install in the reverse order of removal.

#### NOTE:

Hang the back side of rear diffuser on diffuser bracket to install.

#### *Tightening torque:*

*<Ref. to EI-19, DIFFUSER, COMPONENT, General Description.>*

# Diffuser

EXTERIOR/INTERIOR TRIM

---