

HOW TO USE THIS MANUAL

1. How to Use This Manuals

A: HOW TO USE THIS MANUALS

1. STRUCTURE

Each section consists of SCT that are broken down into SC that are divided into sections for each component. The specification, maintenance and other information for the components are included, and diagnosis information has also been added where necessary.

2. INDEX

The first page has an index with tabs.

3. COMPONENTS

Illustrations are listed for each component. The information necessary for repair work (tightening torque, grease up points, etc.) is described on these illustrations. Information is described using symbol.

To order the parts, refer to parts catalogue.

Example:

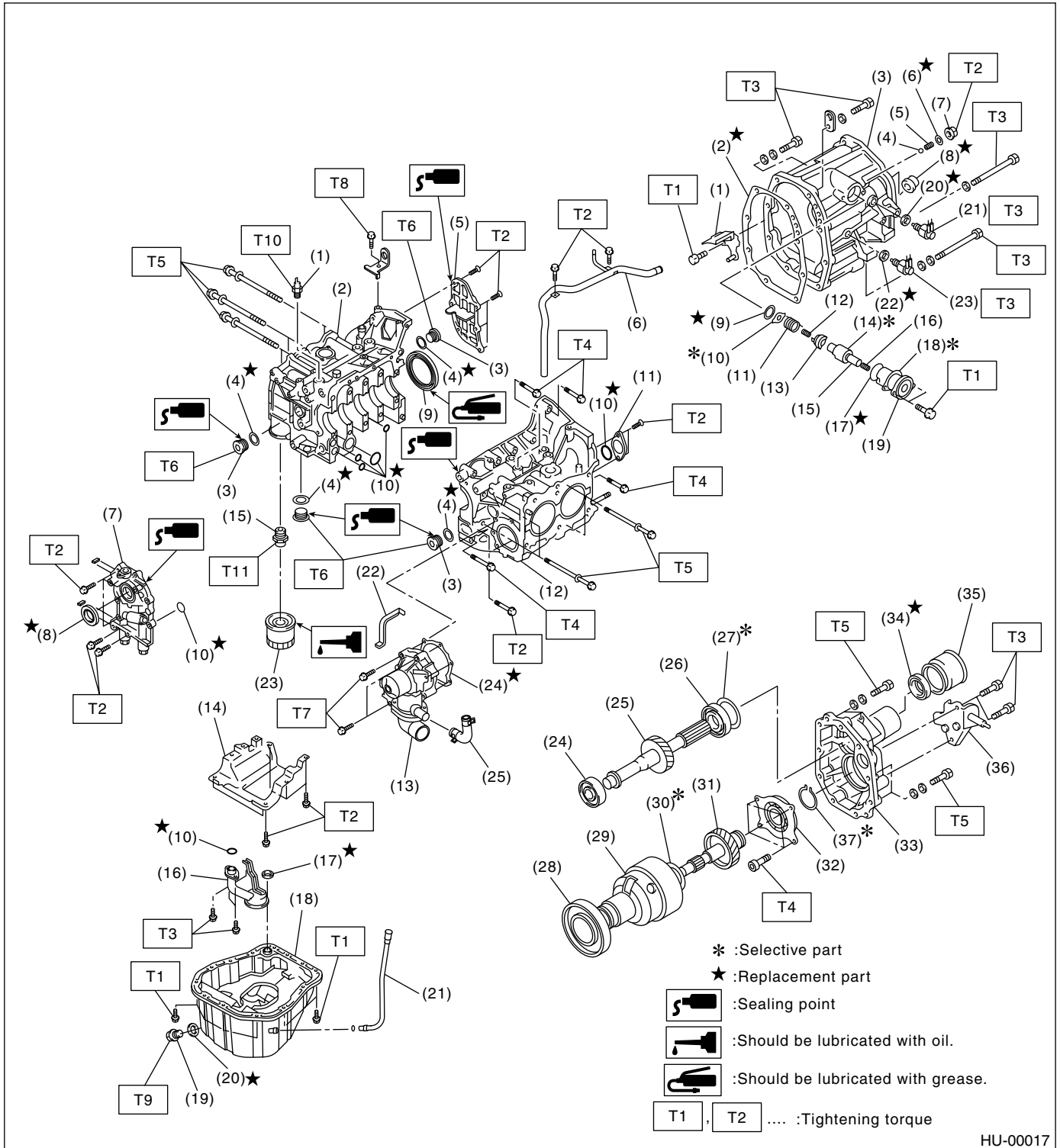

HU-00017

How to Use This Manuals

HOW TO USE THIS MANUALS

4. SPECIFICATION

If necessary, specifications are also included.

5. INSPECTION

Inspections are included to be carried out before and after maintenance.

6. MAINTENANCE

- Maintenance instructions for serviceable parts describes work area and detailed steps with illustration. It also describes the use of special tool, tightening torque, cautions for each procedure.
- If many serviceable parts are included in one service procedure, appropriate reference are provided for each part.

Example:

15. Main Shaft Assembly for Single-Range ← (A)

A: REMOVAL ← (B)

1) Remove the manual transmission assembly from vehicle. <Ref. to MT-33, REMOVAL, Manual Transmission Assembly.> ← (C)

11) Tighten the lock nuts to the specified torque using ST1 and ST2.

NOTE: ← (D)
Secure the lock nuts in two Places after tightening.

ST1 498937000 TRANSMISSION HOLDER

ST2 499987003 ^(E) SOCKET WRENCH (35) _(F)

Tightening torque: ← (G)
118 N·m (12.0 kgf-m, 86.8 ft-lb)

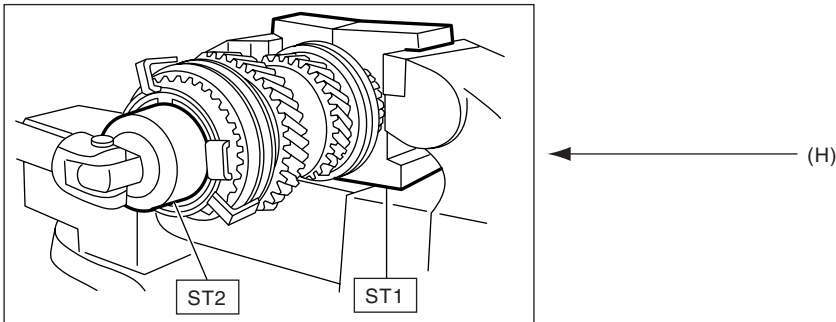

HU-00020

(A) Component

(B) Process

(C) Reference

(D) Caution

(E) Tool number of special tool

(F) Name of special tool

(G) Tightening torque

(H) Illustration

7. DIAGNOSIS

Tables showing a step-by-step process make it easy to conduct diagnosis.

8. SI UNITS

Measurements in these manuals are according to the SI units. Metric and yard/pound measurements are also included.

Example:

Tightening torque:

44 N·m (4.5 kgf-m, 33 ft-lb)

How to Use This Manuals

HOW TO USE THIS MANUALS

9. EXPLANATION OF TERMINOLOGY

• List

AAI	: Air Assist Injection	ISC	: Idle Speed Control
A/B	: Airbag	LED	: Light Emitting Diode
ABS	: Antilock Brake System	LH	: LH (Left Hand)
A/C	: Air Conditioner	LSD	: Limited Slip Differential
ACC	: Accessory	M/B	: Main Fuse & Relay Box
A/F	: Air Fuel Ratio	MD	: Mini Disk
ALT	: Generator	MPi	: Multi Point Injection
ASSY	: Assembly	MP-T	: Multi-Plate Transfer
AT	: Automatic Transmission	MT	: Manual Transmission
ATF	: Automatic Transmission Fluid	Non-turbo	: Natural Aspiration
AVCS	: Active Valve Control System	NC	: Normal Close (Relay)
AWD	: All Wheel Drive	NO	: Normal Open (Relay)
BATT	: Battery	OP	: Option Parts
CAN	: Controller Area Network	OBD	: On-Board Diagnosis
CD-R/RW	: CD Recordable/ReWritable	P/S	: Power Steering
COMPL	: Complete	P/W	: Power Window
CPU	: Central Processing Unit	PCD	: Pitch Circle Diameter
DCCD	: Driver's Control Center Differential	PCV	: Positive Crankcase Ventilation
DOHC	: Double Overhead Camshaft	PID	: Parameter Identification
DTC	: Diagnosis Trouble Code	RAM	: Random Access Memory
DOJ	: Double Offset Joint	RH	: RH (Right Hand)
DVD	: Digital Versatile Disc or Digital Video Disc	ROM	: Read Only Memory
EBD	: Electric Brake Distribution	rpm	: Revolution Per Minute
ECU	: Engine Control Module	SOHC	: Single Overhead Camshaft
EGI	: Electronic Gasoline Injection	SRS	: Supplemental Restraint System
E/G	: Engine	SSM	: Subaru Select Monitor
EGR	: Exhaust Gas Recirculation	ST	: Special Tool
ELR	: Emergency Locking Retractor	STD	: Standard
EX	: Exhaust	SW	: Switch
ETC	: Electric Throttle Control	T/B	: Turbocharger
F/B	: Fuse & Joint Box	TGV	: Tumble Generated Valve
FL	: Fusible Link	T/M	: Transmission
FWD	: Front Wheel Drive	UV	: Ultraviolet
GPS	: Global Positioning System	VIN	: Vehicle Identification Number
HID	: High-Intensity Discharge	ViS-C	: Viscous Coupling
H/U	: Hydraulic Unit	VSV	: Vacuum Switching Valve
IG	: Ignition	VTD	: Variable Torque Distribution
IN	: Intake	W/H	: Wiring Harness
INT	: Intermittent	Pr	: Primary
I/O	: Input / Output	2ndr	: Secondary