

Brought to you by Eris Studios
NOT FOR RESALE

LIGHTING SYSTEM

1. General Description

A: SPECIFICATION

Headlight	Halogen type low beam		12 V — 55 W
	HID type low beam		D2S 35W
	High beam		12 V — 60 W
Front turn signal light			12 V — 21 W (WY21W)
Clearance / Parking / Front side marker light			12 V — 5 W
Front fog light			12 V — 55 W
Rear combination light	Sedan	Tail / Rear side marker / Stop light	12 V — 5/21 W
		Tail light	12 V — 5/21 W
		Stop light	12 V — 21 W
	Wagon	Tail / Rear side marker / Stop light	12 V — 5/21 W
		Turn signal light	12 V — 21 W (WY21W)
		Back-up light	12 V — 21 W
License plate light			12 V — 5 W
High-mounted stop light	Sedan	Standard type	12 V — 21 W
		Rear spoiler built-in type	12 V — 1.2 W (LED)
	Wagon		12 V — 13 W
Room light			12 V — 8 W
Spot map light			12 V — 8 W
Luggage room light			12 V — 5 W
Trunk room light			12 V — 5 W
Glove box light			12 V — 1.4 W

B: CAUTION

- Before removing or installing parts, always disconnect the battery ground cable from battery. When replacing the radio, control unit, and other parts provided with memory functions, record the memory contents before disconnecting the battery ground cable. Otherwise, the memory is cleared.
- Reassemble the parts in the reverse order of disassembly procedure unless otherwise indicated.
- Adjust parts to the given specifications.
- Connect the connectors and hoses securely during reassembly.
- After reassembly, make sure functional parts operate smoothly.

WARNING:

- **The airbag system wiring harness is routed near electrical parts and switches.**
- **Do not use the electrical test equipment on the airbag system wiring harnesses and connector circuits.**
- **Be careful not to damage the airbag system wiring harness when servicing electrical parts and switches.**

C: PREPARATION TOOL

1. GENERAL TOOL

TOOL NAME	REMARKS
Circuit tester	Used for measuring resistance and voltage.

2. Headlight and Tail Light System

A: WIRING DIAGRAM

1. HALOGEN TYPE HEADLIGHT

<Ref. to WI-117, WIRING DIAGRAM, Headlight System.>

2. HID TYPE HEADLIGHT

<Ref. to WI-117, WIRING DIAGRAM, Headlight System.>

3. CLEARANCE LIGHT AND ILLUMINATION LIGHT

<Ref. to WI-127, WIRING DIAGRAM, Clearance Light and Illumination Light System.>

B: INSPECTION

1. HEADLIGHT SWITCH

<Ref. to LI-12, INSPECTION, Combination Switch (Light).>

2. HEADLIGHT RELAY

Measure the headlight relay resistance between terminals when connecting terminal No. 4 to the battery positive terminal and terminal No. 3 to the battery ground terminal.

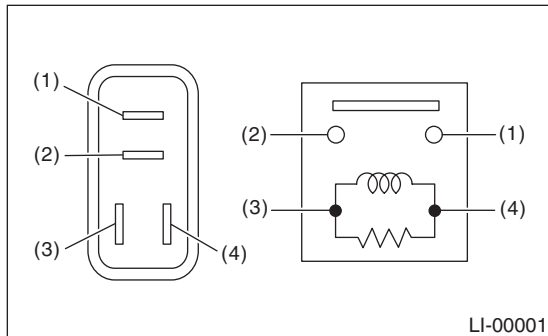

Continuity	Terminal No.	Standard
Flow	1 and 2	Less than 1 Ω
No flow		1 MΩ or more

3. TAIL AND ILLUMINATION RELAY

Measure the resistance between the tail and illumination relay terminals when connecting terminal No. 4 to the battery positive terminal and terminal No. 3 to the battery ground terminal.

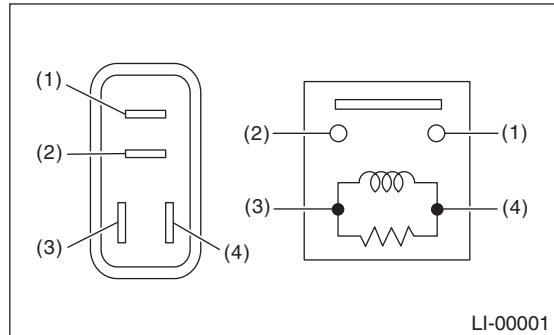

Continuity	Terminal No.	Standard
Flow	1 and 2	Less than 1 Ω
No flow		1 MΩ or more

Day Time Running Light System

LIGHTING SYSTEM

3. Day Time Running Light System

A: WIRING DIAGRAM

<Ref. to WI-117, WIRING DIAGRAM, Headlight System.>

B: INSPECTION

1. DAYTIME RUNNING LIGHT MODULE CHECK (CONTROLLED BY THE BODY INTEGRATED UNIT)

Step	Check	Yes	No
1 CHECK POWER SUPPLY CIRCUIT. 1) Turn the ignition switch to ON. 2) Measure the voltage between the body integrated unit terminal and chassis ground. <i>Connector & terminal</i> <i>(B281) No. 19 (+) — Chassis ground (-):</i>	Is the voltage battery voltage?	Go to step 2.	Check the fuse and the ignition circuit.
2 CHECK GROUND CIRCUIT. 1) Disconnect the body integrated unit connector. 2) Measure the resistance between the body integrated unit terminal and chassis ground. <i>Connector & terminal</i> <i>(B280) No. 13 — Chassis ground:</i>	Is the resistance less than 1 Ω?	Go to step 3.	Check the ground circuit.
3 CHECK THE STARTER SIGNAL. 1) Connect the body integrated unit connector. 2) Turn the ignition switch to ON ⇔ Starter and measure the voltage of terminal. <i>Connector & terminal</i> <i>(B280) No. 15 (+) — Chassis ground (-):</i>	Does the voltage change to 0 ⇔ battery voltage?	Go to step 4.	Check the starter switch circuit.
4 CHECK GENERATOR SIGNAL. Start the engine and measure the voltage between the body integrated unit terminal and chassis ground. <i>Connector & terminal</i> <i>(B280) No. 12 (+) — Chassis ground (-):</i>	Is the voltage above the battery voltage?	Go to step 5.	Check the generator L terminal circuit.
5 CHECK THE PARKING SIGNAL. 1) Turn the ignition switch to ON. 2) Measure the resistance between the body integrated unit terminal and chassis ground when the parking brake lever is applied and when it is released. <i>Connector & terminal</i> <i>(B280) No. 1 (+) — Chassis ground (-):</i>	Does the voltage change to 0 ⇔ battery voltage?	Go to step 6.	Check the parking brake switch circuit.
6 CHECK P RANGE SIGNAL. 1) Turn the ignition switch to ON. 2) Measure the resistance between the body integrated unit terminal and chassis ground when the select lever is set in the P range. <i>Connector & terminal</i> <i>(B281) No. 5 — Chassis ground:</i>	Is the resistance less than 1 Ω?	Go to step 7.	Check the inhibitor switch circuit.
7 CHECK HEADLIGHT (LO). Check that the light turns ON when the headlight switch is set from OFF ⇔ LO.	Does the headlight (LO) light properly?	Go to step 8.	Check the headlight (LO). <Ref. to LI-19, INSPECTION, Headlight Bulb.>
8 CHECK HEADLIGHT (HI). Check that the light turns ON when the headlight switch is set from OFF ⇔ HI.	Does the headlight (HI) light properly?	Halogen type model ⇒ Go to step 10. Model with HID ⇒ Go to step 9.	Check the headlight (HI). <Ref. to LI-19, INSPECTION, Headlight Bulb.>

Day Time Running Light System

LIGHTING SYSTEM

	Step	Check	Yes	No
9	CHECK TAIL LIGHT. Check that the tail light turns ON when the headlight switch is turned ON.	Does the tail light turn ON properly?	Go to step 10.	Check the tail light. <Ref. to LI-27, INSPECTION, Tail/ Stop Light Bulb.>
10	CHECK BODY INTEGRATED UNIT. 1) Turn the headlight switch to OFF and start the engine. 2) Measure the voltage between the body integrated unit terminal and chassis ground with the parking brake released. Connector & terminal (B280) No. 16 (+) — Chassis ground (-):	Is the voltage battery voltage?	Go to step 11.	Check the harness circuit between the headlight relay and body integrated unit.
11	CHECK BODY INTEGRATED UNIT. Measure the voltage between the body integrated unit terminal and chassis ground with the parking brake applied. Connector & terminal (B280) No. 16 (+) — Chassis ground (-):	Is the voltage less than 1 V?	Go to step 12.	Replace the body integrated unit.
12	CHECK DAYTIME RUNNING LIGHT RELAY (HALOGEN TYPE MODEL) AND TAIL LIGHT RELAY (HID MODEL). Disconnect the relay connector, and perform individual inspection. <Ref. to LI-6, DAYTIME RUNNING LIGHT RELAY (SEDAN MODEL) AND TAIL LIGHT RELAY (HID MODEL), INSPECTION, Day Time Running Light System.>	Are individual relays operating properly?	Halogen type model ⇒ Go to step 13. For HID models, check the HID light circuit.	Replace the daytime running light relay (halogen type model) and tail light relay (HID model).
13	CHECK DAYTIME RUNNING LIGHT RESISTOR. Disconnect the daytime running light resistor connector, and measure the resistance between the terminals. Connector & terminal (B5) No. 1 — No. 2:	Is the resistance 0.2 — 0.4 Ω?	Go to step 14.	Replace the daytime running light resistor.
14	CHECK HARNESS BETWEEN DAYTIME RUNNING LIGHT RELAY CONNECTOR AND DAYTIME RUNNING LIGHT RESISTOR CONNECTOR. Measure the resistance between harness connectors. Connector & terminal (B102) No. 3 — (B5) No. 1:	Is the resistance less than 1 Ω?	Go to step 15.	Repair the open circuit of the harness between the daytime running light relay connector and daytime running light resistor connector.
15	CHECK DAYTIME RUNNING LIGHT RESISTOR GROUND. Measure the resistance between harness connector terminal and chassis ground. Connector & terminal (B5) No. 2 — Chassis ground:	Is the resistance less than 1 Ω?	The daytime running light system is normal.	Repair the open circuit of the daytime running light resistor ground.

Day Time Running Light System

LIGHTING SYSTEM

2. DAYTIME RUNNING LIGHT RELAY (SEDAN MODEL) AND TAIL LIGHT RELAY (HID MODEL)

Measure the resistance between the relay terminals when connecting terminal No. 3 to the battery positive terminal and terminal No. 5 to the battery ground terminal.

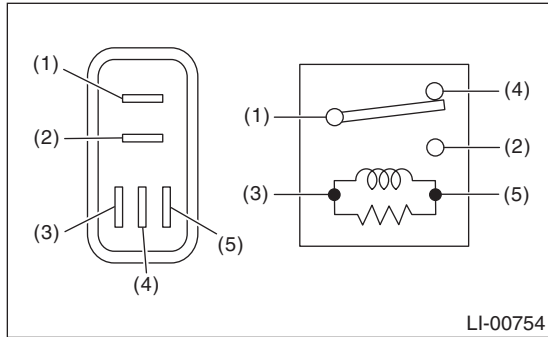

Continuity	Terminal No.	Standard
Flow	1 and 2	Less than 1 Ω
No flow		1 M Ω or more
Flow	1 and 4	1 M Ω or more
No flow		Less than 1 Ω

4. Front Fog Light System

A: WIRING DIAGRAM

1. FRONT FOG LIGHT

<Ref. to WI-124, WIRING DIAGRAM, Front Fog Light System.>

B: INSPECTION

1. FRONT FOG LIGHT SWITCH

Measure the resistance between front fog light switch terminals.

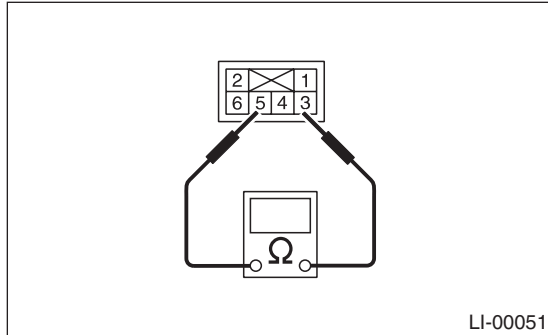

Switch position	Terminal No.	Standard
OFF	3 and 5	1 MΩ or more
ON		Less than 1 Ω

2. FRONT FOG LIGHT RELAY

Connect terminal No. 4 to battery positive terminal and terminal No. 3 to battery ground terminal, and measure the front fog light relay resistance between terminals.

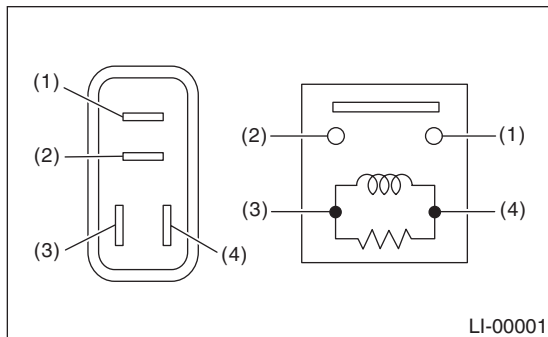

Continuity	Terminal No.	Standard
Flow	1 and 2	Less than 1 Ω
No flow		1 MΩ or more

Turn Signal Light and Hazard Light System

LIGHTING SYSTEM

5. Turn Signal Light and Hazard Light System

A: WIRING DIAGRAM

1. TURN SIGNAL LIGHT AND HAZARD LIGHT

<Ref. to WI-133, WIRING DIAGRAM, Turn Signal Light and Hazard Light System.>

B: INSPECTION

1. TURN SIGNAL SWITCH

<Ref. to LI-12, INSPECTION, Combination Switch (Light).>

2. HAZARD SWITCH

Measure the resistance between terminals of the hazard switch.

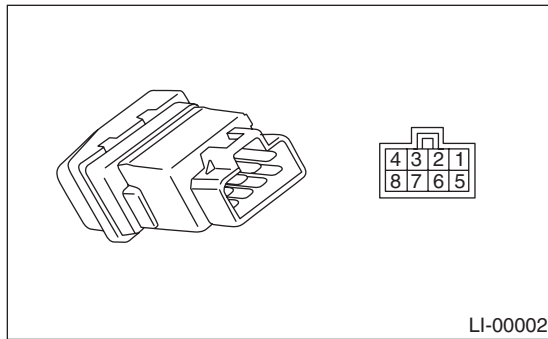

Switch position	Terminal No.	Standard
OFF	6 and 7	Less than 1 Ω
ON	1, 3 and 4	Less than 1 Ω
	7 and 8	Less than 1 Ω

3. TURN SIGNAL AND HAZARD MODULE

Connect the battery and the turn signal light bulb to the module, as shown in the figure. The module is properly functioning if it blinks when power is supplied to the circuit.

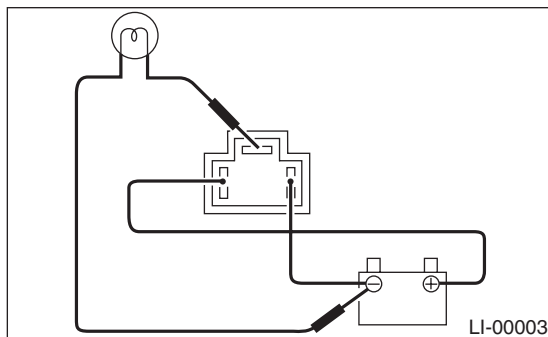

6. Back-up Light System

A: WIRING DIAGRAM

1. BACK-UP LIGHT

<Ref. to WI-125, WIRING DIAGRAM, Back-up Light System.>

B: INSPECTION

1. BACK-UP LIGHT SWITCH (MT MODEL)

Measure the resistance between the back-up light switch terminals.

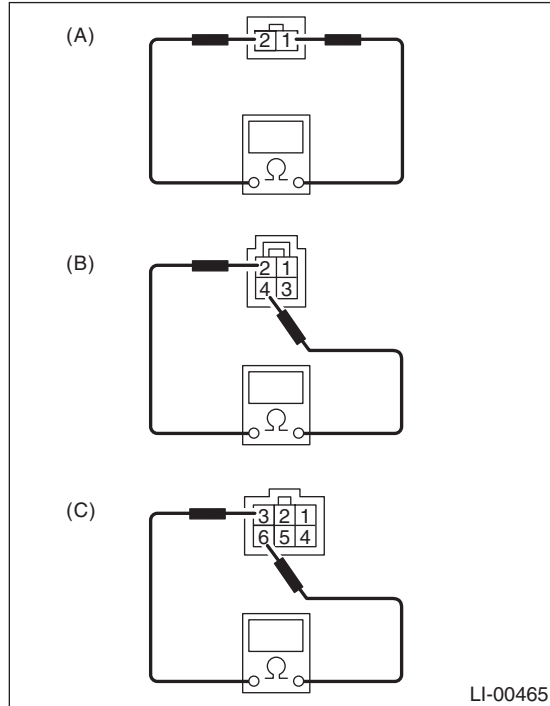

- (A) Non-turbo model
- (B) Turbo model (except for STI model)
- (C) Turbo model (STI model)

Switch position	Terminal No.	Standard
When shift lever is set in reverse position	Turbo model (except for STI model): 2 and 4 Turbo model (STI model): 3 and 6	Less than 1 Ω
Other positions	non-turbo model: 1 and 2	1 MΩ or more

2. INHIBITOR SWITCH (AT MODEL)

Measure the resistance between the inhibitor switch terminals.

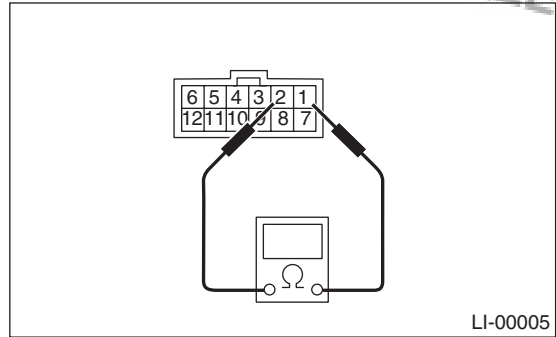

Switch position	Terminal No.	Standard
When the selector lever is in the "R" range	1 and 2	Less than 1 Ω
Other positions		1 MΩ or more

Brought to you by Eris Studios
NOT FOR RESALE

7. Stop Light System

A: WIRING DIAGRAM

1. STOP LIGHT

<Ref. to WI-126, WIRING DIAGRAM, Stop Light System.>

B: INSPECTION

1. STOP LIGHT SWITCH

Measure the resistance between stop light switch terminals.

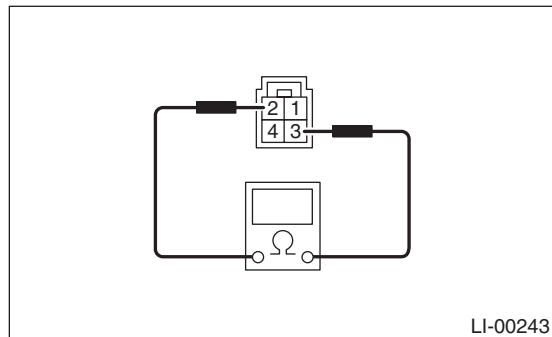

Switch position	Terminal No.	Standard
When brake pedal is depressed	2 and 3	Less than 1 Ω
When brake pedal is released		1 MΩ or more

8. Room Light System

A: WIRING DIAGRAM

1. ROOM LIGHT

<Ref. to WI-135, WIRING DIAGRAM, Interior Light System.>

B: INSPECTION

1. DOOR SWITCH

Measure the resistance between door switch terminals.

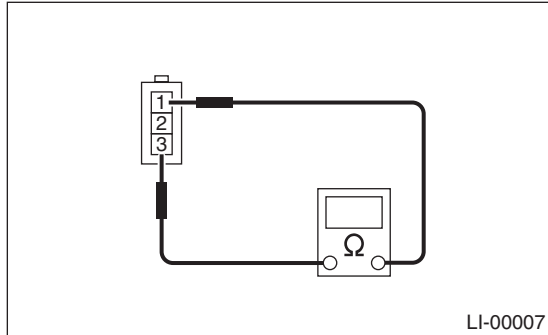

Switch position	Terminal No.	Standard
When door is opened	1 and 3	Less than 1 Ω
When door is closed		1 MΩ or more

2. REAR GATE LATCH SWITCH

Measure the resistance between rear gate latch switch terminals.

Switch position	Terminal No.	Standard
When rear gate is opened	1 and 2	Less than 1 Ω
When rear gate is closed		1 MΩ or more

3. TRUNK ROOM LIGHT SWITCH

Measure the resistance between the trunk room light switch terminals.

Switch position	Terminal No.	Standard
When trunk lid is opened	1 and 2	Less than 1 Ω
When trunk lid is closed		1 MΩ or more

Combination Switch (Light)

LIGHTING SYSTEM

9. Combination Switch (Light)

A: REMOVAL

- 1) Disconnect the ground cable from the battery.
- 2) Remove the instrument panel lower cover. <Ref. to EI-47, REMOVAL, Instrument Panel Assembly.>
- 3) Remove the screws which secure upper column cover to lower column cover.

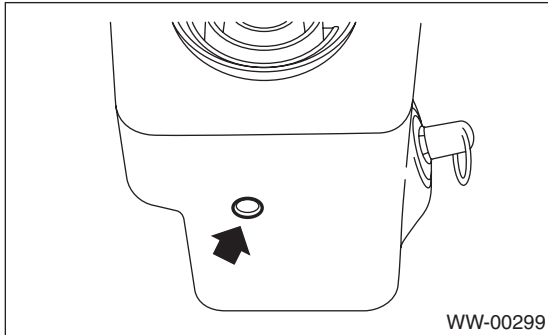

- 4) Remove the steering column upper cover mounting screw.

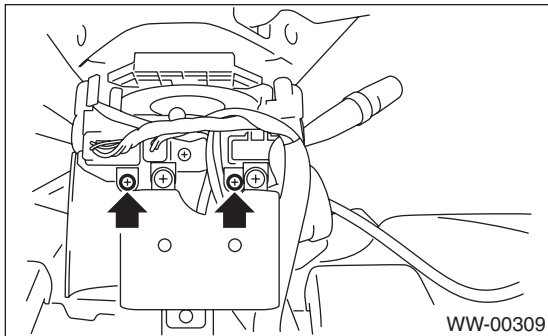

- 5) Disconnect the connector from the combination switch.
- 6) Remove the screws which secure the switch, then remove the switch.

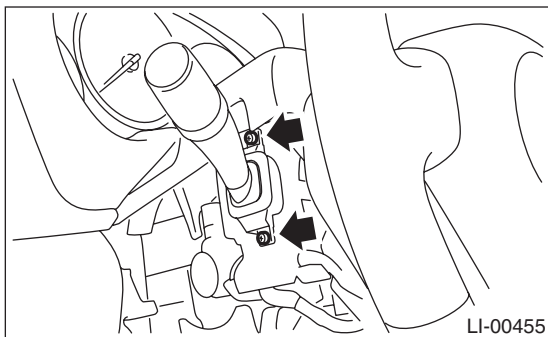

B: INSTALLATION

Install in the reverse order of removal.

C: INSPECTION

Measure the resistance between combination switch terminals.

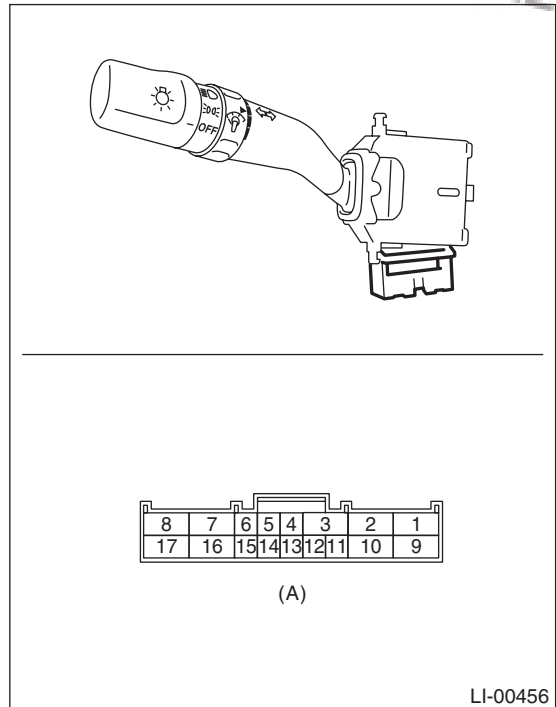

(A) Light / turn signal switch connector

1. LIGHTING SWITCH

Switch position	Terminal No.	Standard
OFF	13, 14 and 16	1 MΩ or more
Tail	14 and 16	Less than 1 Ω
Head	13, 14 and 16	Less than 1 Ω

2. DIMMER AND PASSING SWITCH

Switch position	Terminal No.	Standard
Passing	7, 8 and 16	Less than 1 Ω
Low beam	16 and 17	Less than 1 Ω
High beam	7 and 16	Less than 1 Ω

3. TURN SIGNAL SWITCH

Switch position	Terminal No.	Standard
Left	1 and 2	Less than 1 Ω
Neutral	1, 2 and 3	1 MΩ or more
Right	2 and 3	Less than 1 Ω

10. Headlight Beam Leveler System

A: WIRING DIAGRAM

1. HEADLIGHT BEAM LEVELER SYSTEM

<Ref. to WI-123, WIRING DIAGRAM, Headlight Beam Leveler System.>

B: INSPECTION

1. HEADLIGHT BEAM LEVELER ACTUATOR

- 1) Turn on the headlight.
- 2) Confirm the headlight beam level is lowered by changing the switch position to 0 → 1 → 2 → 3.

2. HEADLIGHT BEAM LEVELER SWITCH

Measure the resistance between the headlight beam leveler switch terminals.

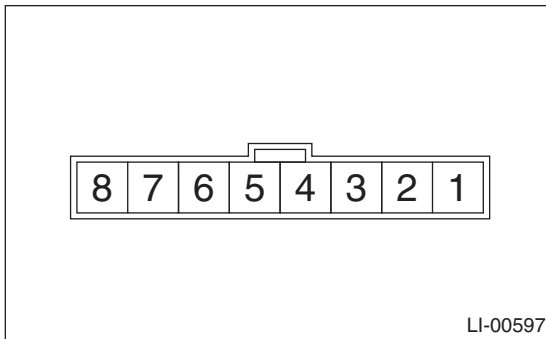

Switch position	Terminal No.	Standard
0	3 and 5	Approx. 1 kΩ
1		Approx. 1,845 Ω
2		Approx. 2,650 Ω
3		Approx. 3,310 Ω

Combination Base Switch Assembly

LIGHTING SYSTEM

11. Combination Base Switch Assembly

A: REMOVAL

- 1) Remove the driver's airbag module. <Ref. to AB-13, REMOVAL, Driver's Airbag Module.>
- 2) Remove the steering wheel. <Ref. to PS-18, REMOVAL, Steering Wheel.>
- 3) Remove the steering cover.
- 4) Remove the combination switch. <Ref. to LI-12, REMOVAL, Combination Switch (Light).> <Ref. to WW-6, REMOVAL, Combination Switch (Wiper).>
- 5) Remove the four screws and remove the roll connector.
- 6) Remove the three screws.

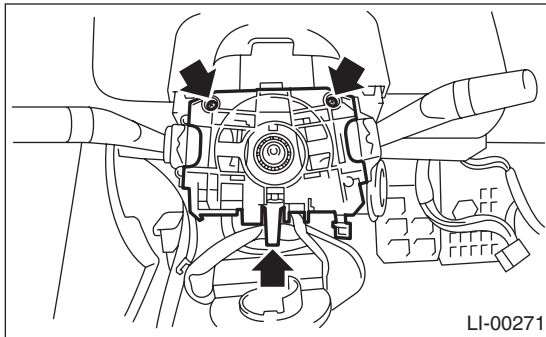

- 7) Disconnect the connector and remove the combination base switch assembly.

B: INSTALLATION

- 1) Install in the reverse order of removal.
- 2) Before installing steering wheel, be sure to adjust the direction of roll connector with steering. <Ref. to AB-19, INSTALLATION, Roll Connector.>

C: INSPECTION

1. COMBINATION BASE SWITCH ASSEMBLY

Check for the following, and replace the damaged parts with new parts.

Combination base switch assembly and roll connectors are cracked or deformed.

2. PARKING SWITCH

Measure the resistance between parking switch terminals.

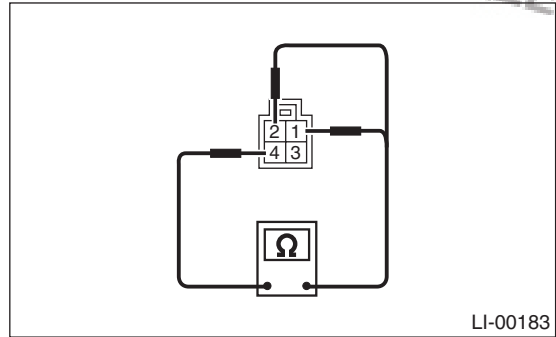

Switch position	Terminal No.	Standard
OFF	2 and 4	Less than 1 Ω
ON	1 and 4	Less than 1 Ω

12. Headlight Assembly

A: REMOVAL

- 1) Disconnect the ground cable from the battery.
- 2) Remove the duct (when right side headlight is removed).

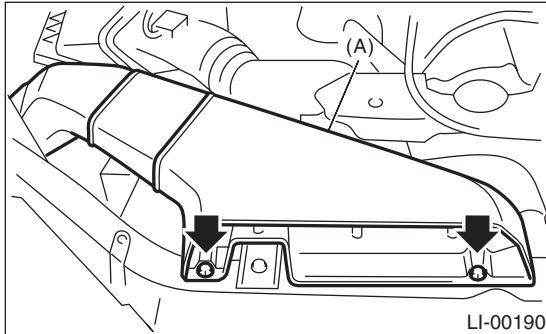

- 3) Remove the front bumper. <Ref. to EI-24, REMOVAL, Front Bumper.>
- 4) Disconnect harness connectors.
- 5) Remove the headlight assembly side section bolts.

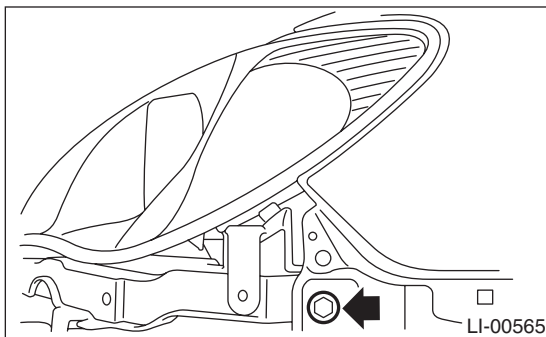

- 6) Remove the 3 bolts, disengage the clip, then detach the headlight assembly.

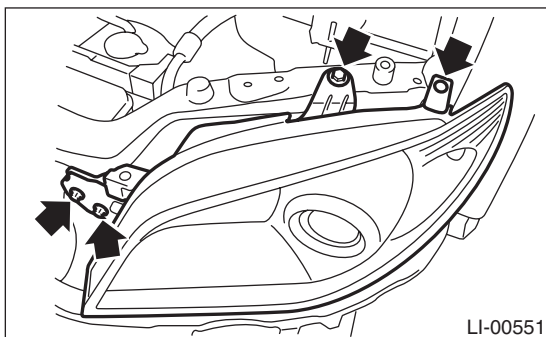

B: INSTALLATION

Install in the reverse order of removal.

C: DISASSEMBLY

1. HID HEADLIGHT BALLAST

CAUTION:

- Do not operate with wet hands.
- As the HID headlight uses high voltages in the lighting circuit, be sure to confirm that the power supply is turned off before operation.
- Do not leave the headlight without a ballast for long periods of time. Dust, moisture, etc. entering the headlight may affect its performance.

- 1) Disconnect the ground cable from the battery.
- 2) Remove the headlight assembly. <Ref. to LI-15, REMOVAL, Headlight Assembly.>
- 3) Remove the back cover.

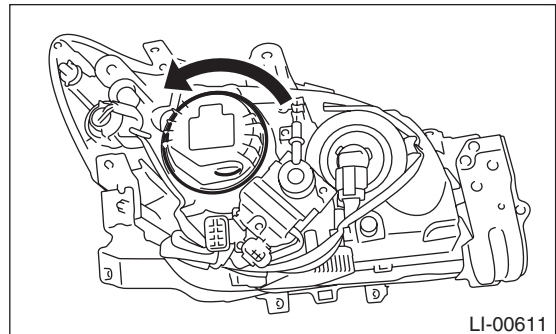

- 4) Disconnect the harness connector.

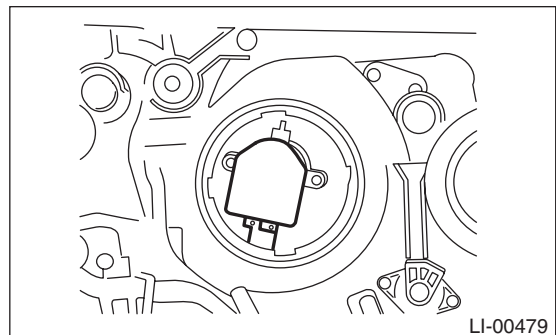

- 5) Loosen the screw and remove the ballast body.

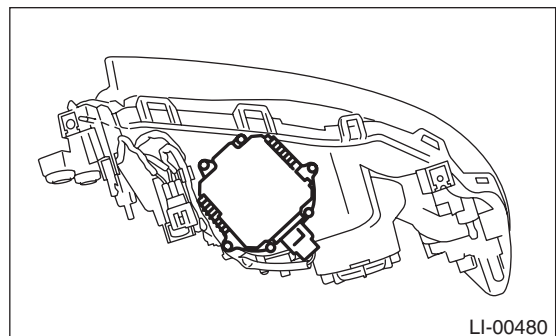

LIGHTING SYSTEM

6) Disconnect the connector from the headlight ballast.

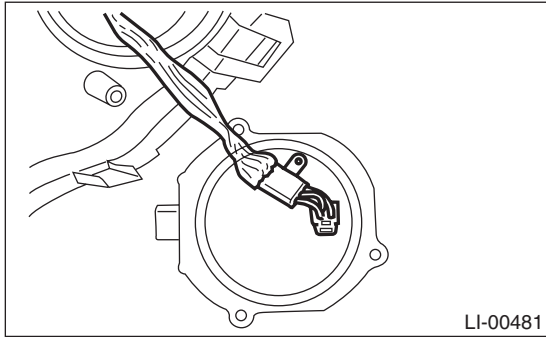

CAUTION:

Be careful as the claw is easily broken.

7) Turn the level adjustment screw so that the beam is pointed upwards, and make space so that the socket can pass through the inside of the lamp.

CAUTION:

Make sure that the reflector does not interfere with the extension case.

8) Insert the socket towards the front of the reflector bracket.

9) Turn the level adjustment screw so that the beam is pointed downward, and make space so that the socket can pass through the lower side of the reflector bracket.

CAUTION:

Make sure that the reflector does not interfere with the extension case.

10) From the lower side of the housing, pull the socket out of the headlight.

CAUTION:

Do not get the socket caught between the reflector and light housing.

D: ASSEMBLY

1. HID HEADLIGHT BALLAST

Assemble in the reverse order of disassembly.

E: ADJUSTMENT

1. HEADLIGHT BEAM ADJUSTMENT

CAUTION:

Turn off the light before adjusting the headlight beam level. If the light is necessary to check aiming, do not illuminate for two minutes or more.

NOTE:

Before checking the headlight beam level, be sure of the following:

- The area around the headlight has not sustained any accident, damage or other type of deformation.
- Vehicle is parked on level ground.
- The inflation pressure of tires is correct.
- Vehicle's fuel tank is fully filled.

1) Bounce the vehicle several times to normalize the suspension.

2) Make certain that someone is seated in the driver's seat.

3) Measure the distance between the low beam bulb centers, and the height of the bulb center.

4) Light the headlights, and adjust the low beam while projecting onto a screen.

- HALOGEN TYPE

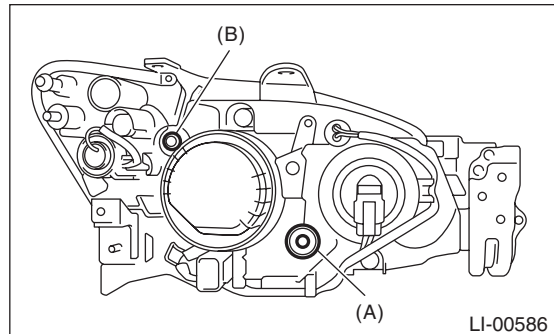

(A) Vertical direction

(B) Horizontal direction

- HID TYPE

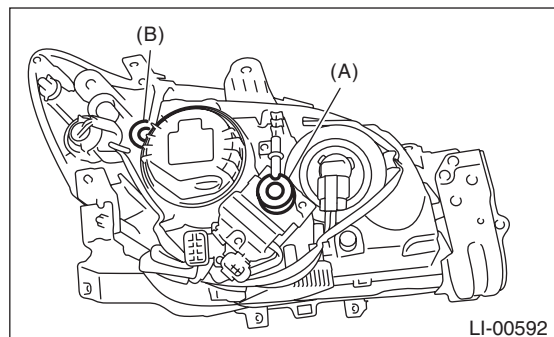

(A) Vertical direction

(B) Horizontal direction

NOTE:

- Set the headlight beam leveler switch to the "0" position.
- First adjust the vertical beam level (A), then the horizontal beam level (B), using a screwdriver.

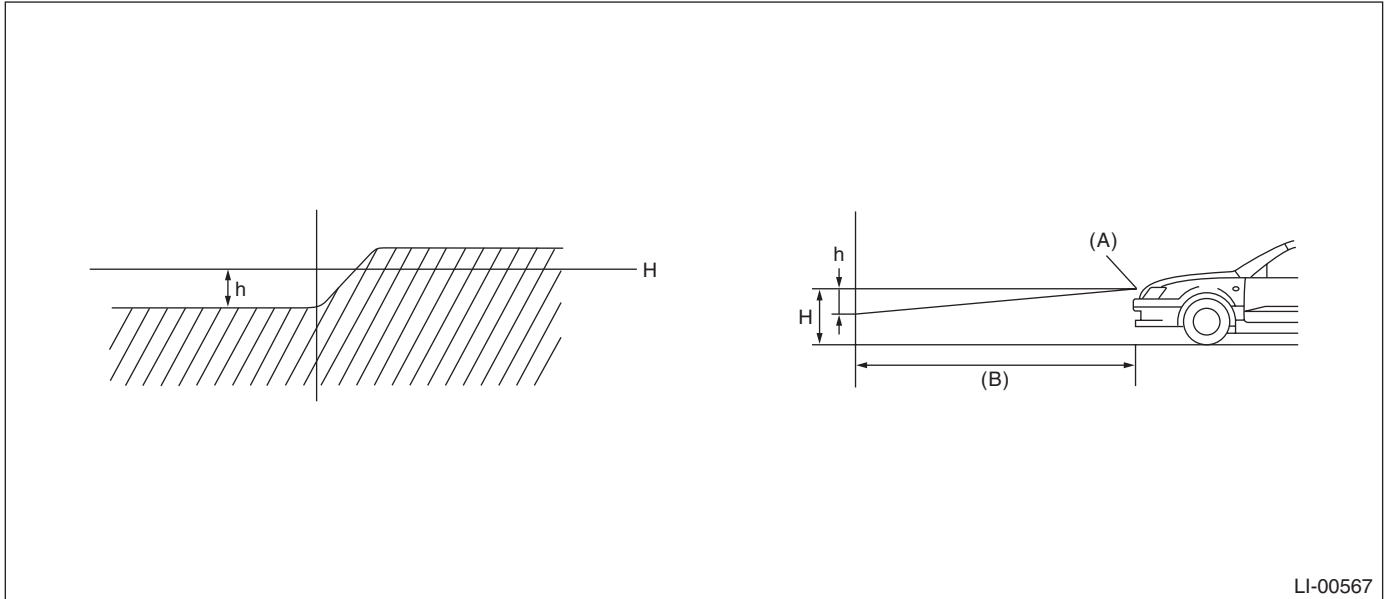

(A) Bulb center marking

(B) 3 m (10 ft)

(H) Bulb center height

When 3m (10 ft) h mm (in)
21 (0.83)

13. Headlight Bulb

A: REMOVAL

1. HIGH BEAM & HALOGEN TYPE LOW BEAM

CAUTION:

- Because the halogen bulb operates at a high temperature, dirt and oil on the bulb surface reduces the bulb's service life. Hold the flange portion when replacing the bulb. Never touch the glass portion.

- Because dust and moisture may enter the headlight and affect performance, do not leave the bulbs removed from the headlight for extended periods of time.

- 1) Disconnect the ground cable from the battery.
- 2) Remove the air intake duct (A) (when right side headlight bulb is removed).

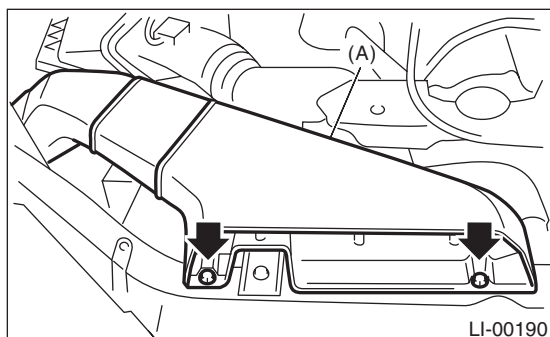

- 3) Disconnect the harness connector.
- 4) Remove bulb assembly (A). To remove the low beam, remove the back cover, and then go to Step 5.

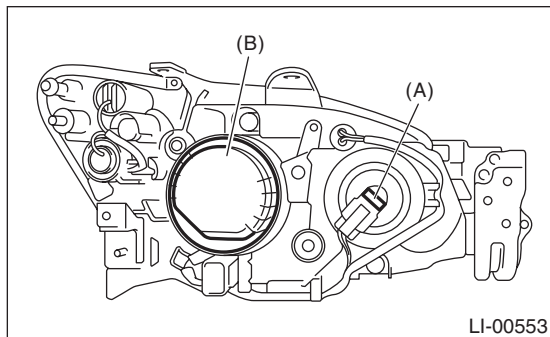

- (A) High beam
- (B) Low beam

- 5) Remove the light bulb retaining spring (A) to remove bulb.

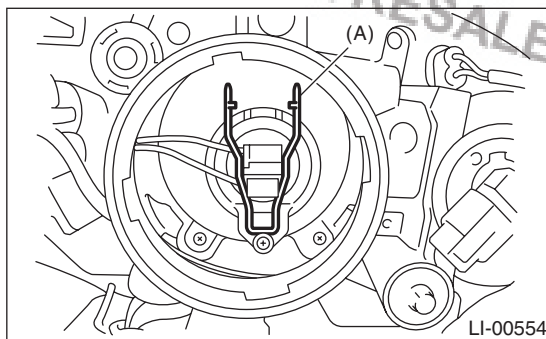

2. HID TYPE LOW BEAM

CAUTION:

- Do not operate with wet hands.
- As the lightening circuit uses high voltage, be sure to confirm that the power supply is turned off before operation.
- When replacing the bulb, hold the flange portion and never touch the glass portion.
- Because dust and moisture may enter the headlight and affect performance, do not leave the bulbs removed from the headlight for extended periods of time.

- 1) Disconnect the ground cable from the battery.
- 2) Remove the headlight assembly. <Ref. to LI-15, REMOVAL, Headlight Assembly.>
- 3) Remove the back cover.

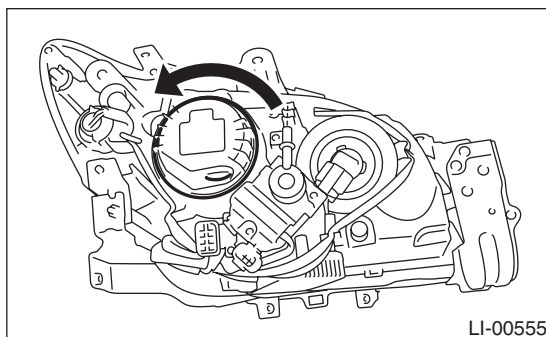

- 4) Disconnect the harness connector.

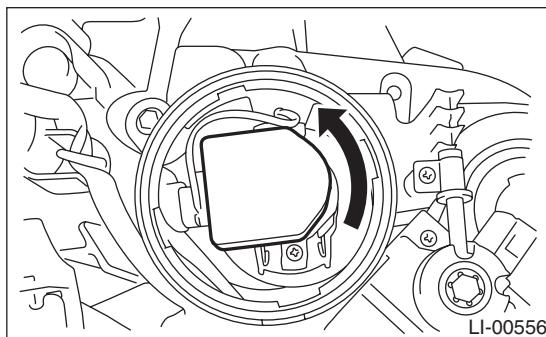

5) Remove the light bulb retaining spring to remove the bulb.

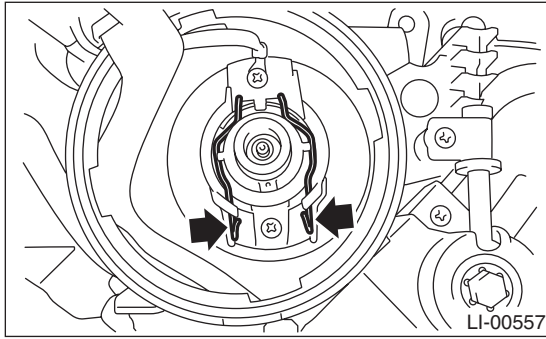

B: INSTALLATION

Install in the reverse order of removal.

C: INSPECTION

1. HALOGEN TYPE

- 1) Visually check the bulb for blow out.
- 2) Check the bulb specification. <Ref. to LI-2, SPECIFICATION, General Description.>
- 3) If NG, replace the bulb with a new part.

2. HID TYPE

CAUTION:

- Do not operate with wet hands.
- Do not touch the harness, inner headlight, or any metallic portion of the headlight when the light is illuminated (when the lighting switch is turned on).
- When performing a lighting test, make sure that the headlight is mounted on the vehicle, and the power supply is connected to the connector on the vehicle's side.

- 1) Check the bulb specification. <Ref. to LI-2, SPECIFICATION, General Description.>
- 2) Install the normal HID bulb to test if it illuminates properly.
- 3) If it does not illuminate properly, replace with a new bulb. <Ref. to LI-19, DISPOSAL, Headlight Bulb.>

4) Check the HID ballast. Check the ballast in the following methods and judge if it can be reused or not.

(1) Perform the cold start (turning on the lights after the headlights is gone off for 10 minutes or more) and hot start (turning on the headlights for more than 15 minutes → turning off the lights for one minute → turning on the lights again) several times and check if the headlights illuminate surely.

(2) Check the lighting condition from immediately after the cold start until the stable condition (approx. 5 min.), to make sure that the unstable condition (flicker etc.) does not occur.

(3) Attach the two bulbs having been used for the same period of time to the right and left headlights and keep the headlights for approx. 30 minutes lit. Check the difference of brightness between right and left headlights.

5) If NG, replace the ballast with a new part.

D: DISPOSAL

1. HID TYPE

CAUTION:

The HID type bulb contains mercury.

When disposing, contact the SOA service center, and dispose it according to local laws and regulations.

14. Front Turn Signal Light Bulb

A: REMOVAL

- 1) Turn the steering fully to the opposite direction of the side with the turn signal bulb to remove.
- 2) Disengage clip and turn the mud guard inward.

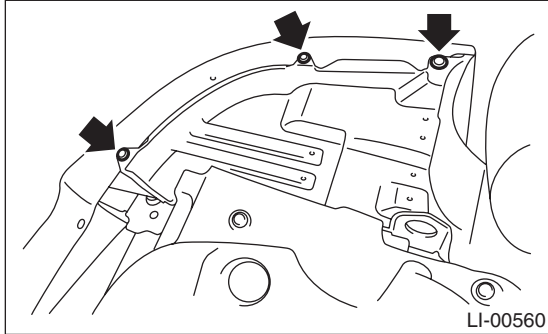

- 3) Turn socket (A) from the wheel arch, and remove the front turn signal light bulb.

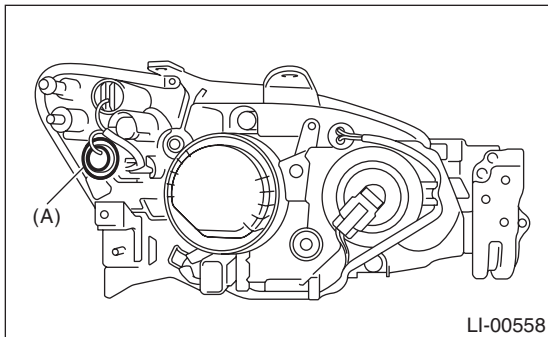

B: INSTALLATION

Install in the reverse order of removal.

C: INSPECTION

- 1) Visually check the bulb for blow out.
- 2) Check the bulb specification. <Ref. to LI-2, SPECIFICATION, General Description.>
- 3) If NG, replace the bulb with a new part.

15. Clearance/Parking Light Bulb

A: REMOVAL

Turn the socket (A) and remove the bulb.

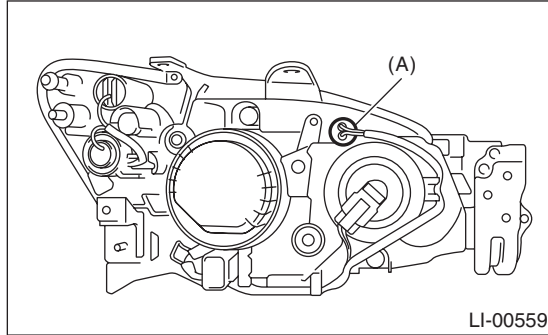

B: INSTALLATION

Install in the reverse order of removal.

C: INSPECTION

- 1) Visually check the bulb for blow out.
- 2) Check the bulb specification. <Ref. to LI-2, SPECIFICATION, General Description.>
- 3) If NG, replace the bulb with a new part.

16. Front Side Marker Light Bulb

A: REMOVAL

- 1) Turn the steering fully to the opposite direction of the side with the turn signal bulb to remove.
- 2) Disengage clip and turn the mud guard inward.

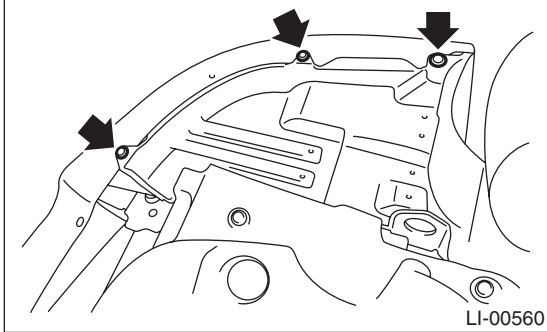

- 3) Turn socket (A) at the wheel arch section, and remove the front side marker light bulb.

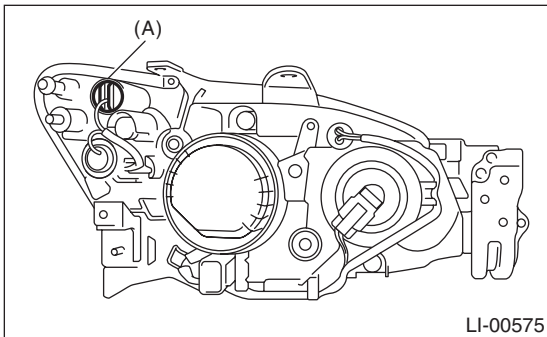

B: INSTALLATION

Install in the reverse order of removal.

C: INSPECTION

- 1) Visually check the bulb for blow out.
- 2) Check the bulb specification. <Ref. to LI-2, SPECIFICATION, General Description.>
- 3) If NG, replace the bulb with a new part.

17. Front Fog Light Assembly

A: REMOVAL

- 1) Disconnect the ground cable from the battery.
- 2) Disengage the three clips, and then turn over the lower mud guard.

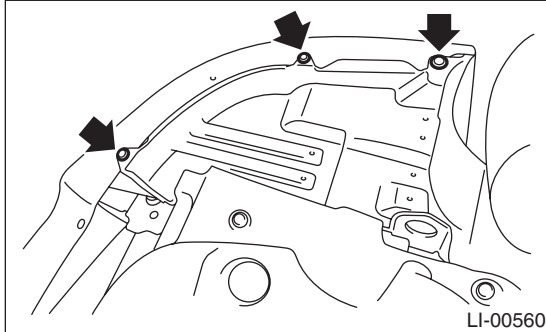

- 3) Remove the harness connector.
- 4) Remove the attachment bolts and remove the fog light assembly.

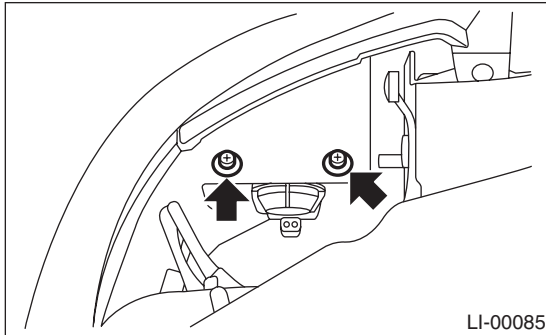

B: INSTALLATION

Install in the reverse order of removal.

C: ADJUSTMENT

1. FOG LIGHT BEAM ADJUSTMENT

NOTE:

Before checking the fog light beam level, be sure of the following:

- The area around the fog light has not sustained any accident, damage or other type of deformation.
- Vehicle is parked on a level surface.
- The inflation pressure of tires is correct.
- Vehicle's fuel tank is fully filled.

- 1) Bounce the vehicle several times to normalize the suspension.
- 2) Make certain that someone is seated in the driver's seat.
- 3) Disengage the three clips, and then turn over the lower mud guard.

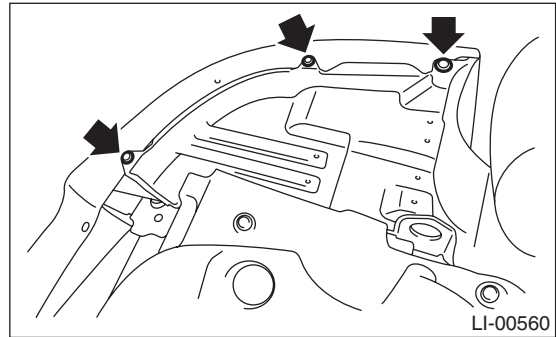

Front Fog Light Assembly

LIGHTING SYSTEM

4) Turn the adjustment knob by hand to adjust the pattern of the fog light.

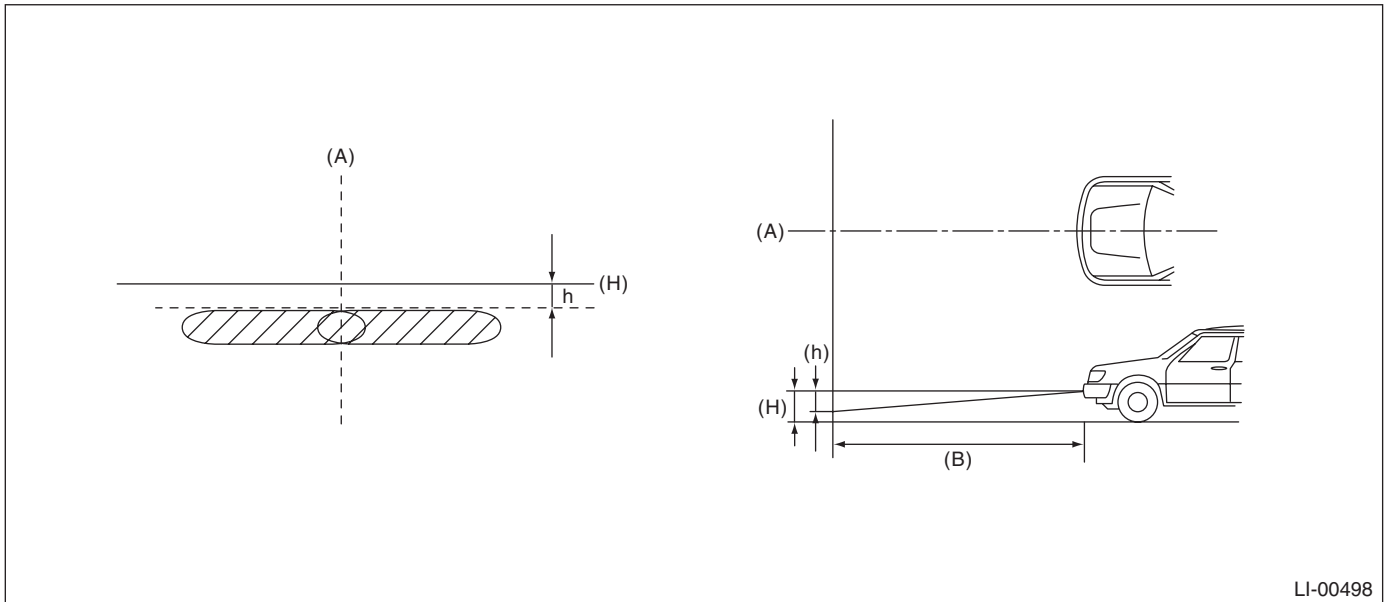
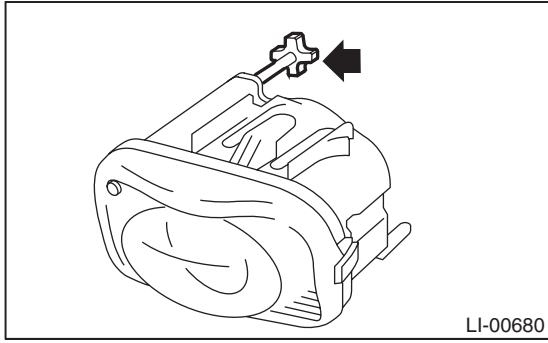

(A) Vehicle center
(B) 3 m (10 ft)

(H) Height of fog light center

(h) 60 mm (2.36 in)

18. Front Fog Light Bulb

A: REMOVAL

- 1) Disconnect the ground cable from the battery.
- 2) Disengage the three clips, and then turn over the lower mud guard.

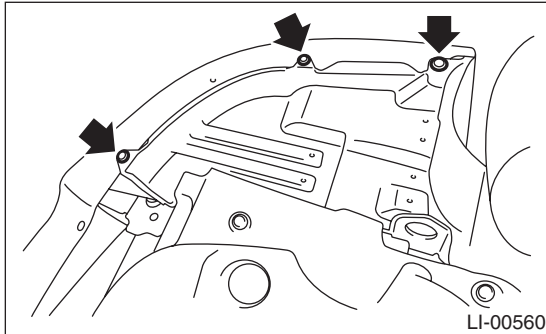

- 3) Remove the harness connector.
- 4) Remove the back cover (A).

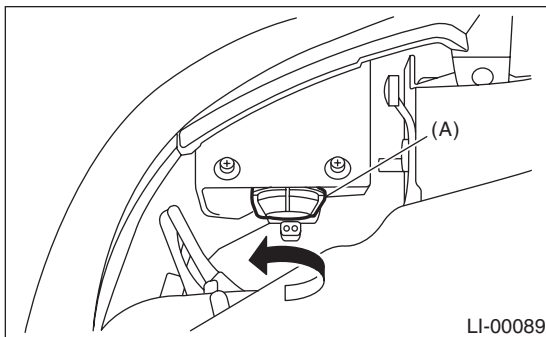

- 5) Remove the spring retainer then detach the fog light bulb.

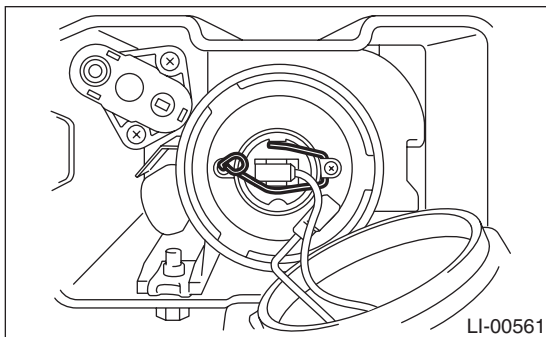

B: INSTALLATION

Install in the reverse order of removal.

C: INSPECTION

- 1) Visually check the bulb for blow out.
- 2) Check the bulb specification. <Ref. to LI-2, SPECIFICATION, General Description.>
- 3) If NG, replace the bulb with a new part.

Rear Combination Light Assembly

LIGHTING SYSTEM

19. Rear Combination Light Assembly

A: REMOVAL

1. SEDAN MODEL

- 1) Disconnect the ground cable from the battery.
- 2) Remove the clips, and then remove the trunk rear trim.

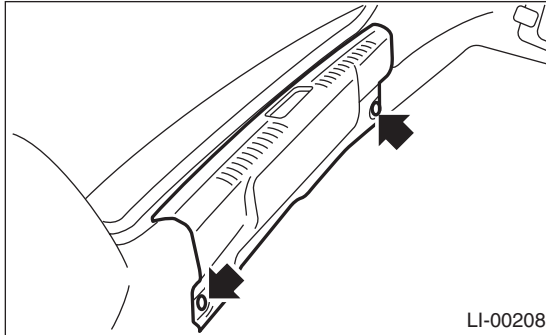

- 3) Remove the trunk side trim of rear portion.
- 4) Remove the four nuts, and then detach the rear combination light after disconnecting the connector.

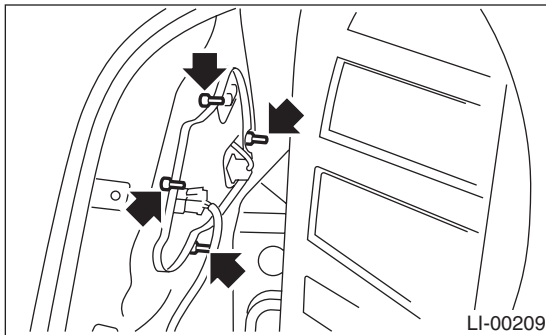

2. WAGON MODEL

- 1) Disconnect the ground cable from the battery.
- 2) Remove the clips and detach the rear combination light covers.

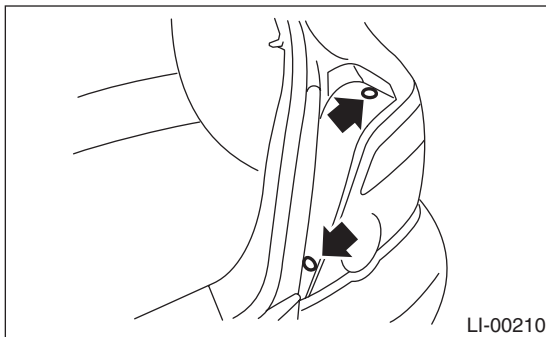

- 3) Remove two bolts, and then remove the rear combination light by pulling it backward.

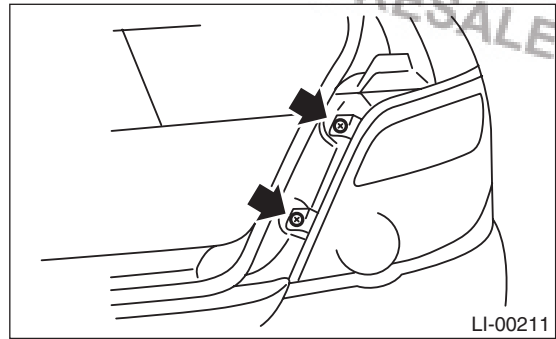

- 4) Disconnect the harness connector and remove the rear combination light.

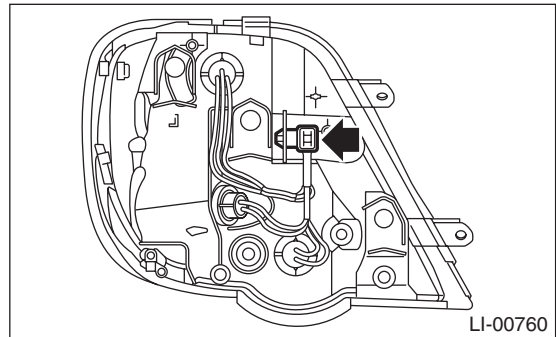

B: INSTALLATION

1. SEDAN MODEL

Install in the reverse order of removal.

2. WAGON MODEL

Install in the reverse order of removal.

NOTE:

Install the rear combination light by aligning the clip with body side.

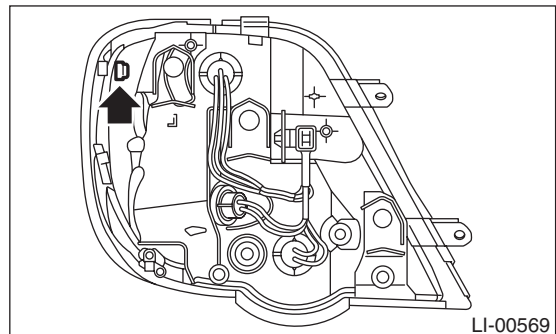

20. Tail/Stop Light Bulb

A: REMOVAL

1. SEDAN MODEL

- 1) Remove the trunk side trim of rear portion.
- 2) Turn the socket and remove the bulb.

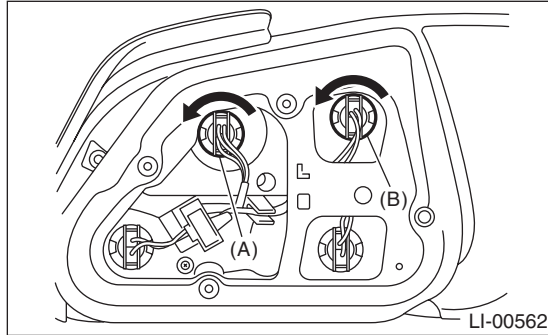

- (A) Tail light
(B) Stop/tail light

2. WAGON MODEL

- 1) Remove the rear combination light assembly.
<Ref. to LI-26, WAGON MODEL, REMOVAL, Rear Combination Light Assembly.>
- 2) Turn the socket and remove the bulb.

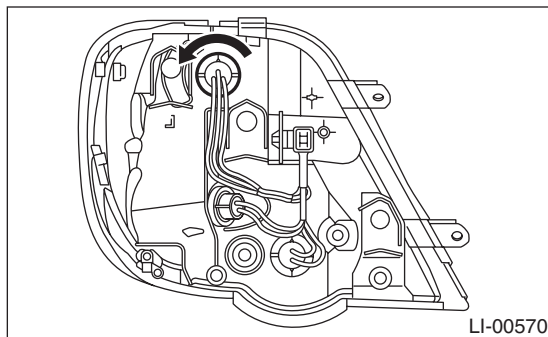

B: INSTALLATION

Install in the reverse order of removal.

C: INSPECTION

- 1) Visually check the bulb for blow out.
- 2) Check the bulb specification. <Ref. to LI-2, SPECIFICATION, General Description.>
- 3) If NG, replace the bulb with a new part.

21. Back-up Light Bulb

A: REMOVAL

1. SEDAN MODEL

- 1) Remove the trunk side trim of rear portion.
- 2) Turn the socket and remove the bulb.

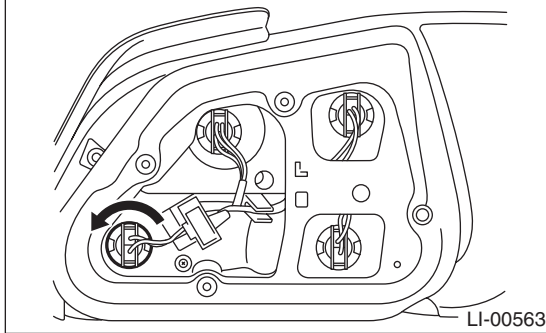

2. WAGON MODEL

- 1) Remove the rear combination light assembly. <Ref. to LI-26, WAGON MODEL, REMOVAL, Rear Combination Light Assembly.>
- 2) Turn the socket and remove the bulb.

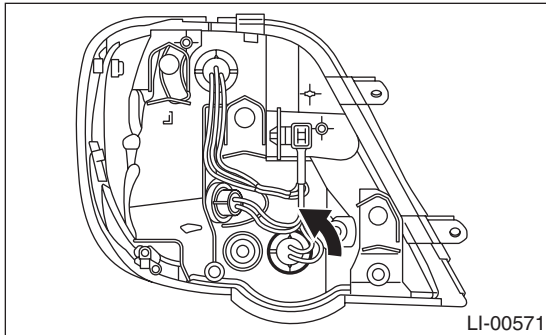

B: INSTALLATION

Install in the reverse order of removal.

C: INSPECTION

- 1) Visually check the bulb for blow out.
- 2) Check the bulb specification. <Ref. to LI-2, SPECIFICATION, General Description.>
- 3) If NG, replace the bulb with a new part.

22. Rear Turn Signal Light Bulb

A: REMOVAL

1. SEDAN MODEL

- 1) Remove the trunk side trim of rear portion.
- 2) Turn the socket and remove the bulb.

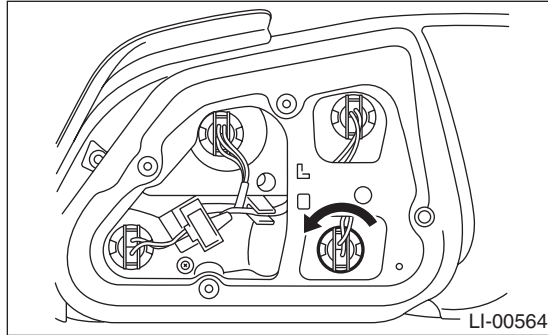

2. WAGON MODEL

- 1) Remove the rear combination light assembly. <Ref. to LI-26, WAGON MODEL, REMOVAL, Rear Combination Light Assembly.>
- 2) Turn the socket and remove the bulb.

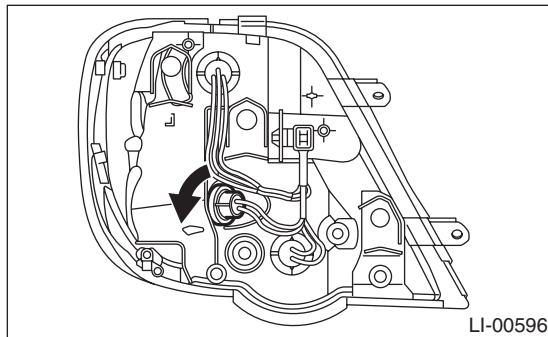

B: INSTALLATION

Install in the reverse order of removal.

C: INSPECTION

- 1) Visually check the bulb for blow out.
- 2) Check the bulb specification. <Ref. to LI-2, SPECIFICATION, General Description.>
- 3) If NG, replace the bulb with a new part.

Brought to you by Eris Studios
NOT FOR RESALE

23. License Plate Light

A: REMOVAL

- 1) Disconnect the ground cable from the battery.
- 2) Remove the license plate light mounting screw (A) and then remove the lens (B).

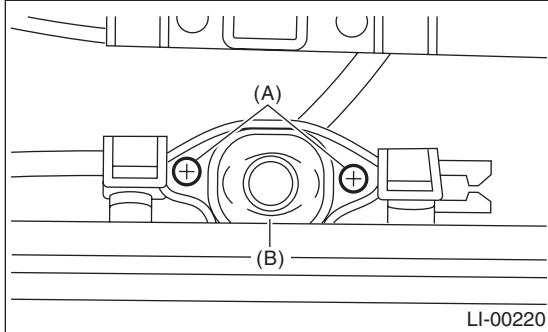

- 3) Remove the bulb.

B: INSTALLATION

Install in the reverse order of removal.

C: INSPECTION

- 1) Visually check the bulb for blow out.
- 2) Check the bulb specification. <Ref. to LI-2, SPECIFICATION, General Description.>
- 3) If NG, replace the bulb with a new part.

24. High-mounted Stop Light

A: REMOVAL

1. SEDAN MODEL (STANDARD TYPE)

- 1) Disconnect the ground cable from the battery.
- 2) Disconnect the connector of high-mounted stop light from body harness.
- 3) Remove the bolts, then detach the high-mounted stop light assembly.

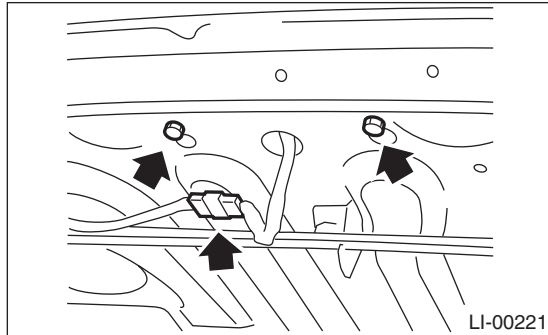

2. SEDAN MODEL (WITH BUILT-IN REAR SPOILER)

- 1) Disconnect the ground cable from the battery.
- 2) Remove the bolts, then detach the high-mounted stop light assembly.

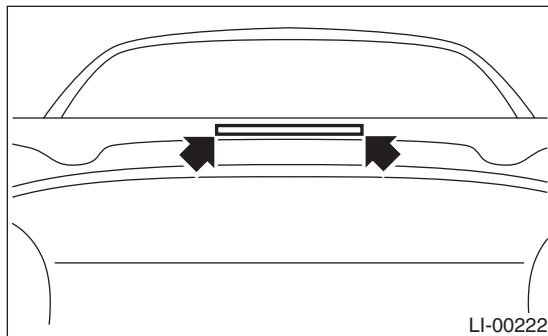

- 3) Disconnect the connector of high-mounted stop light from body harness.

3. WAGON MODEL

- 1) Disconnect the ground cable from the battery.
- 2) Remove the screws (a) and then detach the cover (b).
- 3) Remove the screws (c) and detach the connector, then remove the high mounted stop light.

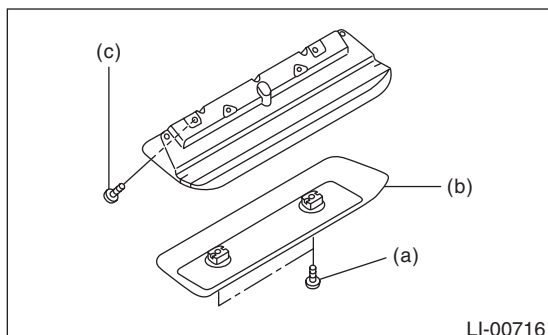

B: INSTALLATION

Install in the reverse order of removal.

C: INSPECTION

- 1) Visually check the bulb for blow out.
- 2) If NG, replace the high mounted stop light with a new part.

Brought to you by Eris Studios
NOT FOR RESALE

25. Spot Map Light

A: REMOVAL

- 1) Disconnect the ground cable from the battery.
- 2) Remove the lens (A) and spot map light mounting screws (B).

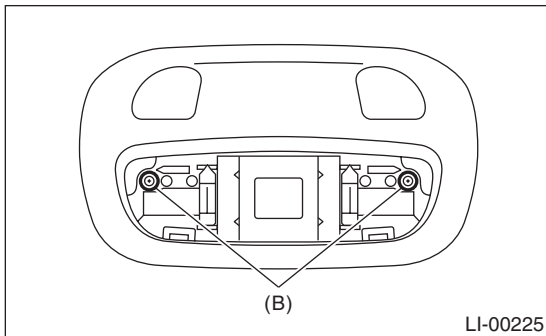
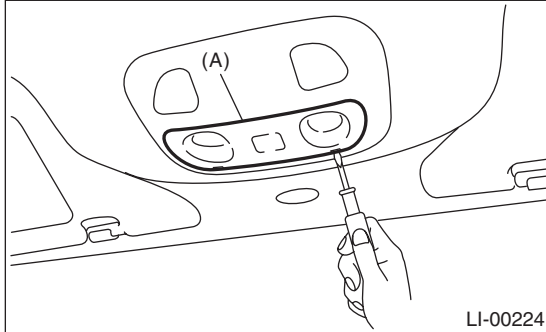

- 3) Disconnect the harness connectors and remove the spot map light.

B: INSTALLATION

Install in the reverse order of removal.

C: INSPECTION

1. SPOT MAP LIGHT BULB

- 1) Visually check the bulb for blow out.
- 2) Check the bulb specification. <Ref. to LI-2, SPECIFICATION, General Description.>
- 3) If NG, replace the bulb with a new part.

2. SPOT MAP LIGHT SWITCH

Measure the resistance between the spot map light terminals.

Switch position	Terminal No.	Standard
OFF	1 and 2	1 MΩ or more
ON	1 and 2	18±5.4 Ω

Brought to you by Eris Studios
NOT FOR RESALE

26. Room Light

A: REMOVAL

- 1) Disconnect the ground cable from the battery.
- 2) Remove the lens (A) and mounting screws (B).

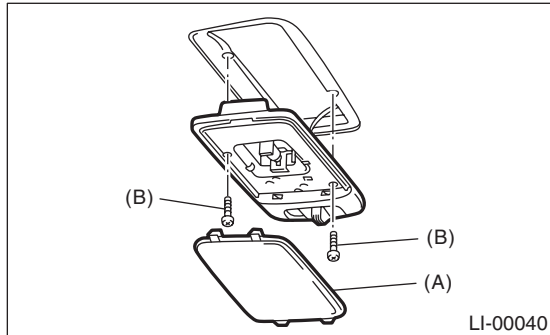

- 3) Disconnect the harness connector and remove the room light.

B: INSTALLATION

Install in the reverse order of removal.

C: INSPECTION

1. ROOM LIGHT BULB

- 1) Visually check the bulb for blow out.
- 2) Check the bulb specification. <Ref. to LI-2, SPECIFICATION, General Description.>
- 3) If NG, replace the bulb with a new part.

2. ROOM LIGHT SWITCH

Measure the resistance between room light terminals.

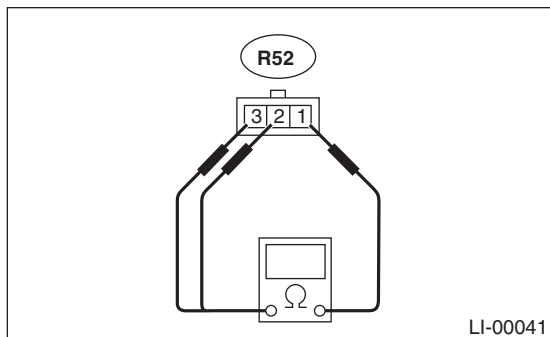

Switch position	Terminal No.	Standard
OFF	—	1 MΩ or more
ON	1 and 3	1.5±0.5 Ω
DOOR	1 and 2	1.5±0.5 Ω

27. Luggage Room Light

A: REMOVAL

- 1) Disconnect the ground cable from the battery.
- 2) Remove the lens (A) and mounting screws (B) of the luggage room light.

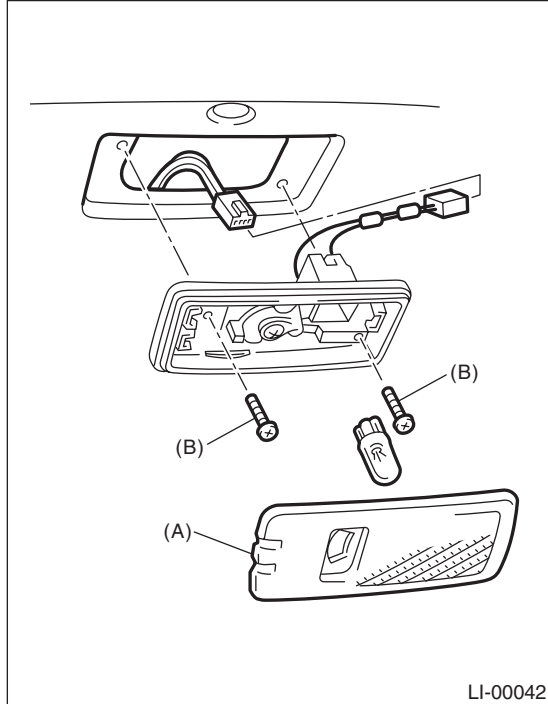

- 3) Disconnect the harness connectors and remove the luggage room light.

B: INSTALLATION

Install in the reverse order of removal.

C: INSPECTION

1. LUGGAGE ROOM LIGHT BULB

- 1) Visually check the bulb for blow out.
- 2) Check the bulb specification. <Ref. to LI-2, SPECIFICATION, General Description.>
- 3) If NG, replace the bulb with a new part.

2. LUGGAGE ROOM LIGHT SWITCH

Measure the resistance between the luggage room light terminals.

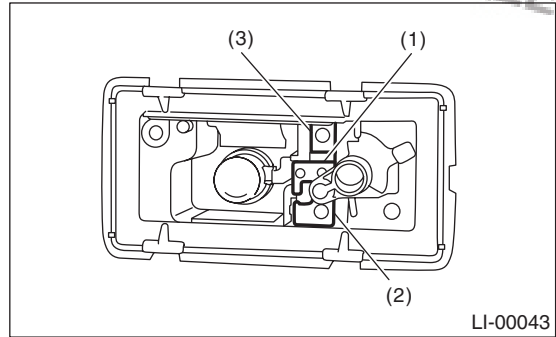

Switch position	Terminal No.	Standard
OFF	—	1 MΩ or more
DOOR	1 and 2	1.5±0.5 Ω

28. Trunk Room Light

A: REMOVAL

- 1) Disconnect the ground cable from the battery.
- 2) Disconnect the harness connector and remove the trunk room light.

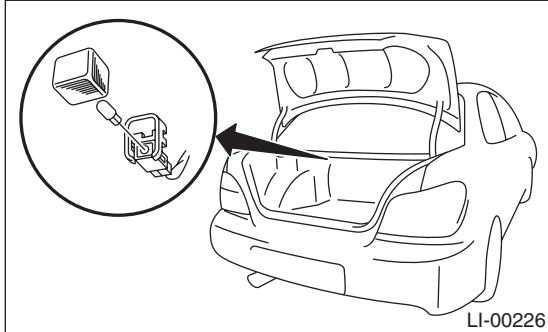

B: INSTALLATION

Install in the reverse order of removal.

C: INSPECTION

- 1) Visually check the bulb for blow out.
- 2) Check the bulb specification. <Ref. to LI-2, SPECIFICATION, General Description.>
- 3) If NG, replace the bulb with a new part.

29. Glove Box Light

A: REMOVAL

- 1) Disconnect the ground cable from the battery.
- 2) Remove the glove box. <Ref. to EI-43, REMOVAL, Glove Box.>
- 3) Disconnect the harness connector.
- 4) Remove the glove box light.

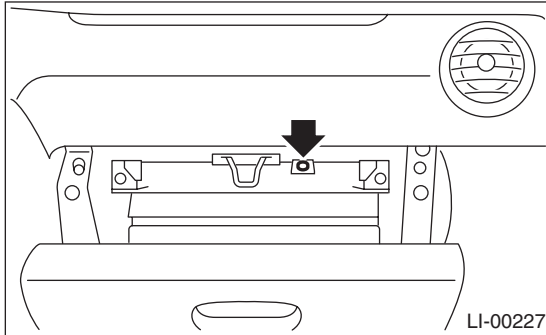

B: INSTALLATION

Install in the reverse order of removal.

C: INSPECTION

- 1) Visually check the bulb for blow out.
- 2) Check the bulb specification. <Ref. to LI-2, SPECIFICATION, General Description.>
- 3) If NG, replace the bulb with a new part.

30. Day Time Running Light Unit

A: REMOVAL

The daytime running light system is controlled by the body integrated unit. <Ref. to SL-56, REMOVAL, Body Integrated Unit.>

B: INSTALLATION

Install in the reverse order of removal.

Day Time Running Light Unit

LIGHTING SYSTEM

Brought to you by Eris Studios
NOT FOR RESALE