

Brought to you by Eris Studios
NOT FOR RESALE

ABS (DIAGNOSTICS)

Basic Diagnostic Procedure

ABS (DIAGNOSTICS)

1. Basic Diagnostic Procedure

A: PROCEDURE

CAUTION:

Remove foreign matter (dust, water, oil etc.) from the ABSCM&H/U connector during removal and installation.

NOTE:

- To check harness for open or short circuits, shake the suspected trouble spot or connector.
- Refer to "Check List for Interview". <Ref. to ABS(diag)-4, Check List for Interview.>

Step	Check	Yes	No
1 CHECK PRE-INSPECTION. 1) Ask the customer when and how the trouble occurred using the interview check list. <Ref. to ABS(diag)-4, Check List for Interview.> 2) Before performing diagnostics, check the components which might affect ABS problems. <Ref. to ABS(diag)-8, INSPECTION, General Description.>	Are components which might affect the ABS problem operating correctly?	Go to step 2.	Repair or replace each component.
2 CHECK INDICATION OF DTC ON SCREEN. 1) Turn the ignition switch to OFF. 2) Connect the Subaru Select Monitor to the data link connector. 3) Turn the ignition switch to ON and run the Subaru Select Monitor. NOTE: If the communication function of the Subaru Select Monitor cannot be executed normally, check the communication circuit. <Ref. to ABS(diag)-18, COMMUNICATION FOR INITIALIZING IMPOSSIBLE, INSPECTION, Subaru Select Monitor.> 4) Read the DTC. <Ref. to ABS(diag)-24, OPERATION, Read Diagnostic Trouble Code (DTC).> 5) Record all DTCs and freeze frame data.	Is DTC displayed?	Go to step 4.	Go to step 3.
3 PERFORM GENERAL DIAGNOSTICS. 1) Perform the inspection using "General Diagnostic Table". <Ref. to ABS(diag)-79, General Diagnostic Table.> 2) Perform the Clear Memory Mode. <Ref. to ABS(diag)-17, CLEAR MEMORY MODE, OPERATION, Subaru Select Monitor.> 3) Perform the Inspection Mode. <Ref. to ABS(diag)-25, Inspection Mode.> 4) Read the DTC. <Ref. to ABS(diag)-15, READ DIAGNOSTIC TROUBLE CODE (DTC), OPERATION, Subaru Select Monitor.> Check the DTC is not displayed.	Does the ABS warning light go off after turning the ignition switch to ON?	Finish the diagnosis.	Check using "ABS Diagnostic Procedure". <Ref. to ABS(diag)-21, WITHOUT DTC, INSPECTION, Subaru Select Monitor.>

Basic Diagnostic Procedure

ABS (DIAGNOSTICS)

	Step	Check	Yes	No
4	PERFORM DIAGNOSIS. 1) Refer to "List of Diagnostic Trouble Code (DTC)". <Ref. to ABS(diag)-34, LIST, List of Diagnostic Trouble Code (DTC).> 2) Correct the cause of trouble. 3) Perform the Clear Memory Mode. <Ref. to ABS(diag)-17, CLEAR MEMORY MODE, OPERATION, Subaru Select Monitor.> 4) Perform the Inspection Mode. <Ref. to ABS(diag)-25, Inspection Mode.> 5) Read the DTC. <Ref. to ABS(diag)-15, READ DIAGNOSTIC TROUBLE CODE (DTC), OPERATION, Subaru Select Monitor.>	Is DTC displayed?	Repeat step 1 to 4 until DTC does not appear.	Finish the diagnosis.

Check List for Interview

ABS (DIAGNOSTICS)

2. Check List for Interview

A: CHECK

Check the following items regarding condition of the vehicle.

1. STATE OF ABS WARNING LIGHT

ABS warning light illuminates.	<input type="checkbox"/> Always <input type="checkbox"/> Sometimes <input type="checkbox"/> Only once <input type="checkbox"/> Does not come on • When and how long does it illuminate?		
Ignition key position	<input type="checkbox"/> LOCK <input type="checkbox"/> ACC <input type="checkbox"/> ON (before starting engine) <input type="checkbox"/> START <input type="checkbox"/> ON (after starting engine, engine is running) <input type="checkbox"/> ON (after starting engine, engine is at a standstill)		
Timing	<input type="checkbox"/> Immediately after turning the ignition ON. <input type="checkbox"/> Immediately after turning the ignition to START.		
	<input type="checkbox"/> When accelerating	—	km/h
		—	MPH
	<input type="checkbox"/> While driving at a constant speed	km/h	MPH
	<input type="checkbox"/> When decelerating	—	km/h
		—	MPH
	<input type="checkbox"/> When turning to the right	Steering angle:	deg
		Steering time:	Sec.
	<input type="checkbox"/> When turning to the left	Steering angle:	deg
		Steering time:	Sec.
	<input type="checkbox"/> When other electrical parts are operating • Parts name: • Operating condition:		

Check List for Interview

ABS (DIAGNOSTICS)

2. STATE OF BRAKE WARNING LIGHT

Brake warning light illuminates.	<input type="checkbox"/> Always <input type="checkbox"/> Sometimes <input type="checkbox"/> Only once <input type="checkbox"/> Does not come on <input type="checkbox"/> When pulling the parking brake lever. <input type="checkbox"/> When releasing the parking brake lever. • When and how long does it illuminate?		
Ignition key position	<input type="checkbox"/> LOCK <input type="checkbox"/> ACC <input type="checkbox"/> ON (before starting engine) <input type="checkbox"/> START <input type="checkbox"/> ON (after starting engine, engine is running) <input type="checkbox"/> ON (after starting engine, engine is at a standstill)		
Timing	<input type="checkbox"/> Immediately after turning the ignition ON. <input type="checkbox"/> Immediately after turning the ignition to START.		
	<input type="checkbox"/> When accelerating	—	km/h
		—	MPH
	<input type="checkbox"/> While driving at a constant speed	km/h	MPH
	<input type="checkbox"/> When decelerating	—	km/h
		—	MPH
	<input type="checkbox"/> When turning to the right	Steering angle:	deg
		Steering time:	Sec.
	<input type="checkbox"/> When turning to the left	Steering angle:	deg
		Steering time:	Sec.
	<input type="checkbox"/> When other electrical parts are operating		
	• Parts name:		
	• Operating condition:		

Check List for Interview

ABS (DIAGNOSTICS)

3. SYMPTOMS

ABS operating condition	<input type="checkbox"/> Does not operate.	
	<input type="checkbox"/> Operates only when applying the brakes suddenly.	Vehicle speed: km/h MPH
	• Procedures for stepping on the brake pedal:	
	a) Operating time:	Sec.
	b) Operating noise: <input type="checkbox"/> Occurs. / <input type="checkbox"/> Does not occur.	
	• What kind of noise?	<input type="checkbox"/> Knocking <input type="checkbox"/> Gong gong <input type="checkbox"/> Thump <input type="checkbox"/> Buzz <input type="checkbox"/> Gong gong buzz <input type="checkbox"/> Others:
c) Reaction force of brake pedal		
	<input type="checkbox"/> Sticks <input type="checkbox"/> Weak pedal resistance <input type="checkbox"/> Strong pedal resistance <input type="checkbox"/> Others:	
Condition of vehicle	a) Directional stability cannot be obtained or the steering does not respond when applying brakes: <input type="checkbox"/> Yes / <input type="checkbox"/> No	
	• When:	<input type="checkbox"/> When turning to the right <input type="checkbox"/> When turning to the left <input type="checkbox"/> When spinning out <input type="checkbox"/> Others:
	b) Directional stability cannot be obtained or the steering does not respond when accelerating: <input type="checkbox"/> Yes / <input type="checkbox"/> No	
	• When:	<input type="checkbox"/> When turning to the right <input type="checkbox"/> When turning to the left <input type="checkbox"/> When spinning out <input type="checkbox"/> Others:
	c) Poor brake performance: <input type="checkbox"/> Yes / <input type="checkbox"/> No	
	• What kind:	<input type="checkbox"/> Braking distance is long. <input type="checkbox"/> Brakes lock or drag. <input type="checkbox"/> Pedal stroke is long. <input type="checkbox"/> Pedal sticks. <input type="checkbox"/> Others:
	d) Poor acceleration: <input type="checkbox"/> Yes / <input type="checkbox"/> No	
	• What kind:	<input type="checkbox"/> Fails to accelerate. <input type="checkbox"/> Engine stalls. <input type="checkbox"/> Others:
	e) Occurrence of vibration: <input type="checkbox"/> Yes / <input type="checkbox"/> No	
	• Where • What kind:	
	f) Occurrence of noise: <input type="checkbox"/> Yes / <input type="checkbox"/> No	
• Where • What kind:		
g) Other troubles occurred: <input type="checkbox"/> Yes / <input type="checkbox"/> No		
• What kind:		

Check List for Interview

ABS (DIAGNOSTICS)

4. CONDITIONS UNDER TROUBLE OCCURRENCE

Environment	a) Weather	<input type="checkbox"/> Fine <input type="checkbox"/> Cloudy <input type="checkbox"/> Rainy <input type="checkbox"/> Snowy <input type="checkbox"/> Others:
	b) Ambient temperature	°C (°F)
	c) Road	<input type="checkbox"/> Inner city <input type="checkbox"/> Suburbs <input type="checkbox"/> Highway <input type="checkbox"/> Local street <input type="checkbox"/> Uphill <input type="checkbox"/> Downhill <input type="checkbox"/> Paved road <input type="checkbox"/> Gravel road <input type="checkbox"/> Muddy road <input type="checkbox"/> Sandy place <input type="checkbox"/> Others:
	d) Road surface	<input type="checkbox"/> Dry <input type="checkbox"/> Wet <input type="checkbox"/> Covered with fresh snow <input type="checkbox"/> Covered with hardened snow <input type="checkbox"/> Frozen slope <input type="checkbox"/> Others:
Condition	a) Brakes	Deceleration: G <input type="checkbox"/> Intermittent / <input type="checkbox"/> Temporary
	b) Accelerator	Acceleration: G <input type="checkbox"/> Intermittent / <input type="checkbox"/> Temporary
	c) Vehicle speed	km/h MPH <input type="checkbox"/> Advancing <input type="checkbox"/> When accelerating <input type="checkbox"/> When decelerating <input type="checkbox"/> At low speed <input type="checkbox"/> When turning <input type="checkbox"/> Others:
	d) Tire inflation pressure	Front RH tire: kPa Front LH tire: kPa Rear RH tire: kPa Rear LH tire: kPa
	e) Degree of wear	Front RH tire: Front LH tire: Rear RH tire: Rear LH tire:
	f) Genuine parts are used.:	<input type="checkbox"/> Yes / <input type="checkbox"/> No
	g) Tire chain is attached.:	<input type="checkbox"/> Yes / <input type="checkbox"/> No
	h) T-type tire is used.:	<input type="checkbox"/> Yes / <input type="checkbox"/> No
	i) Condition of suspension alignment:	
	j) Loaded state:	
	k) Repair parts are used.:	<input type="checkbox"/> Yes / <input type="checkbox"/> No
	• Contents:	
	l) Others:	

3. General Description

A: CAUTION

1. SUPPLEMENTAL RESTRAINT SYSTEM "AIRBAG"

Airbag system wiring harness is routed near the ABS wheel speed sensor and ABSCM&H/U.

CAUTION:

- Airbag system wiring harnesses and connectors are yellow. Do not use electrical test equipment on these circuits.
- Be careful not to damage the airbag system wiring harness when servicing the ABS wheel speed sensor and ABSCM&H/U.

B: INSPECTION

Before performing diagnosis, check the following item which might affect ABS problems.

1. BATTERY

Measure the battery voltage and check electrolyte.

Standard voltage: 12 V or more

Specific gravity: 1.260 or more

2. GROUND

Check the tightening torque of ground (B302) bolt of ABS.

Tightening torque:

13 N·m (1.3 kgf-m, 9.4 ft-lb)

C: PREPARATION TOOL

1. SPECIAL TOOL

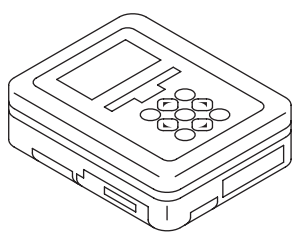
ILLUSTRATION	TOOL NUMBER	DESCRIPTION	REMARKS
 ST1B020XU0	1B020XU0	SUBARU SELECT MONITOR KIT	Used for troubleshooting the electrical system.

2. GENERAL TOOL

TOOL NAME	REMARKS
Circuit tester	Used for measuring resistance, voltage and current.
Oscilloscope	Used for measuring the sensor.

3. BRAKE FLUID

- 1) Check the brake fluid level.
- 2) Check the brake fluid for leaks.

4. HYDRAULIC UNIT

Check the hydraulic unit.

- When using the brake tester <Ref. to ABS-9, CHECKING THE HYDRAULIC UNIT ABS OPERATION WITH THE BRAKE TESTER, INSPECTION, ABS Control Module and Hydraulic Control Unit (ABSCM&H/U).>
- When not using the brake tester <Ref. to ABS-8, CHECKING THE HYDRAULIC UNIT ABS OPERATION BY PRESSURE GAUGE, INSPECTION, ABS Control Module and Hydraulic Control Unit (ABSCM&H/U).>

5. BRAKE DRAG

Check for brake drag.

6. BRAKE PAD AND ROTOR

Check the brake pad and rotor.

- Front <Ref. to BR-20, INSPECTION, Front Brake Pad.> <Ref. to BR-22, INSPECTION, Front Disc Rotor.>
- Rear <Ref. to BR-31, INSPECTION, Rear Brake Pad.> <Ref. to BR-32, INSPECTION, Rear Disc Rotor.>

7. TIRE

Check the tire specifications, tire wear and air pressure. <Ref. to WT-2, SPECIFICATION, General Description.>

4. Electrical Component Location

A: LOCATION

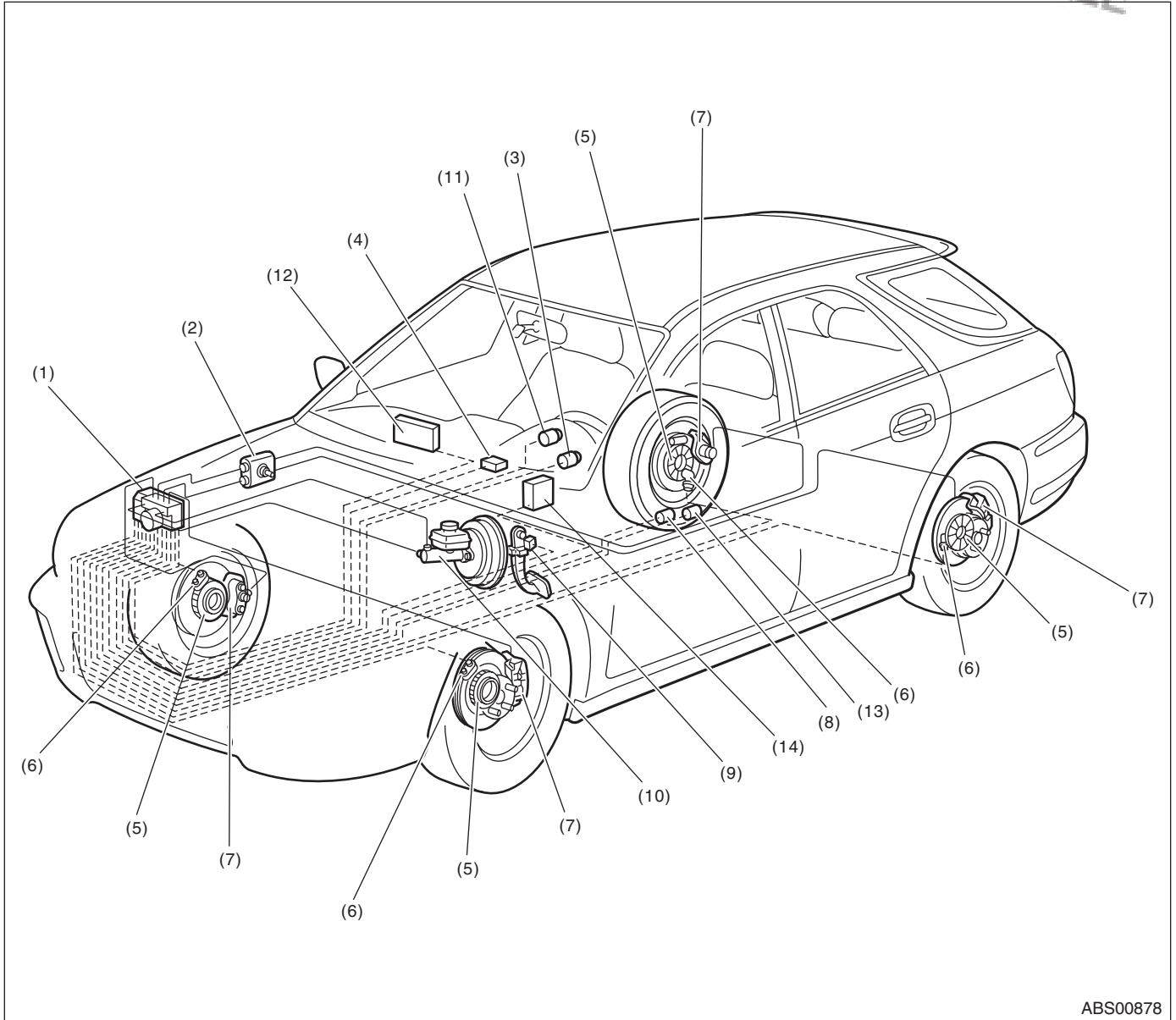

ABS00878

- | | | |
|---|----------------------------------|--|
| (1) ABS control module and hydraulic control unit (ABSCM&H/U) | (6) ABS wheel speed sensor | (12) Driver's control center differential control module (STI model) |
| (2) Connector | (7) Wheel cylinder | (13) Yaw rate & lateral G sensor (STI model) |
| (3) ABS warning light | (8) G sensor | (14) Transmission control module (AT model) |
| (4) Data link connector (For Subaru Select Monitor) | (9) Stop light switch | |
| (5) Tone wheel | (10) Master cylinder | |
| | (11) Brake and EBD warning light | |

Electrical Component Location

ABS (DIAGNOSTICS)

Brought to you by Eris Studios
NOT FOR RESALE

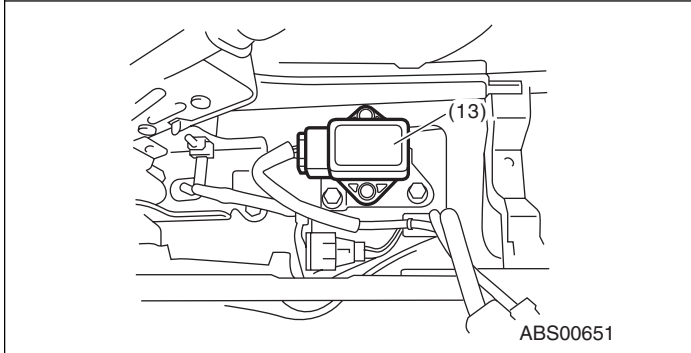
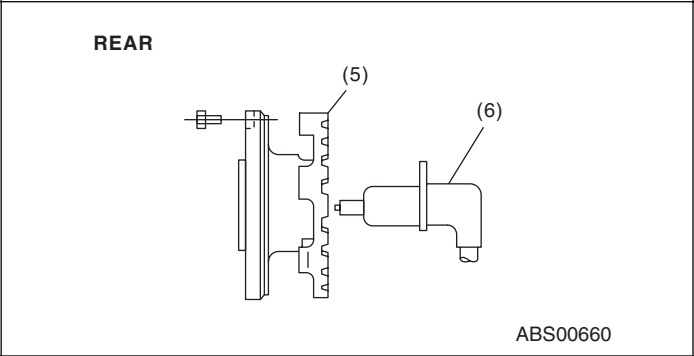
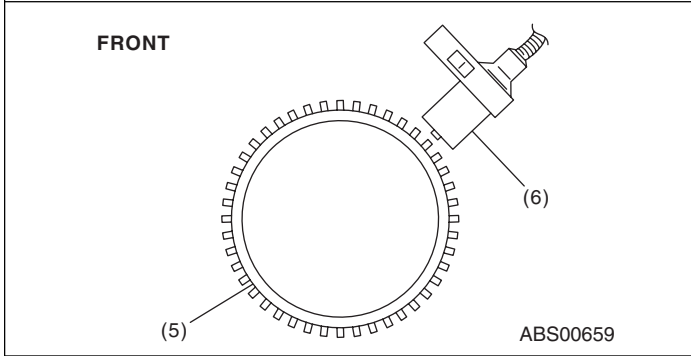
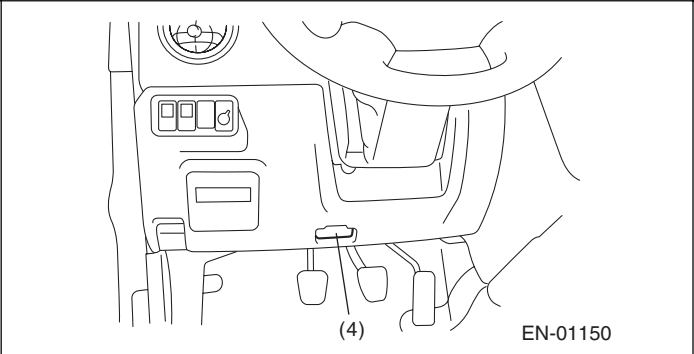
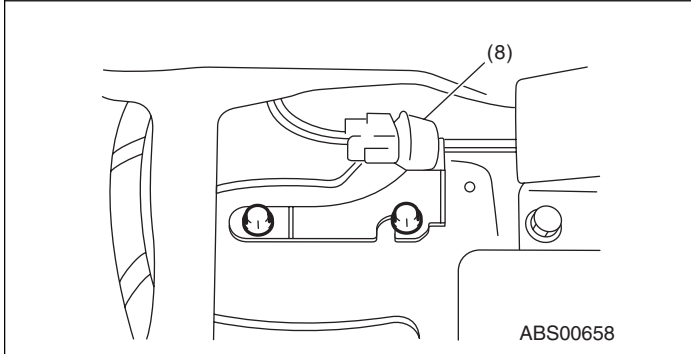
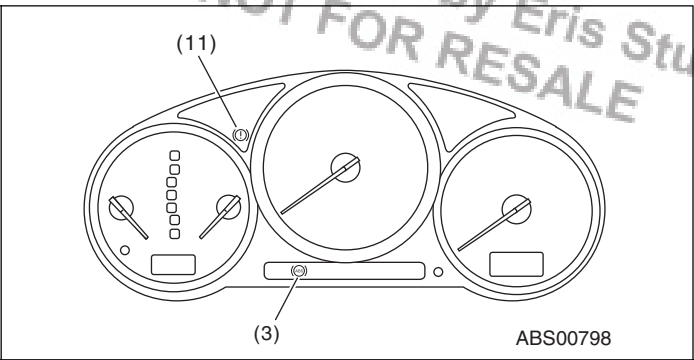
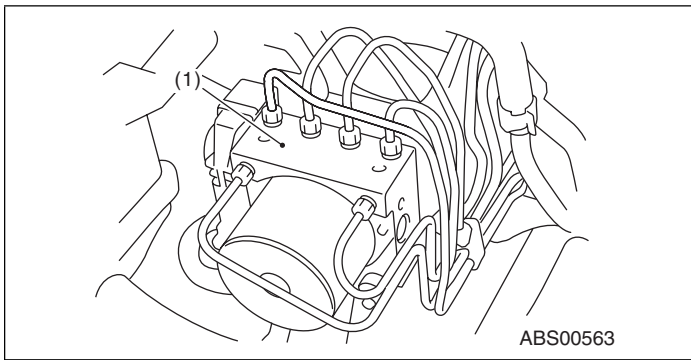

5. Control Module I/O Signal

A: ELECTRICAL SPECIFICATION

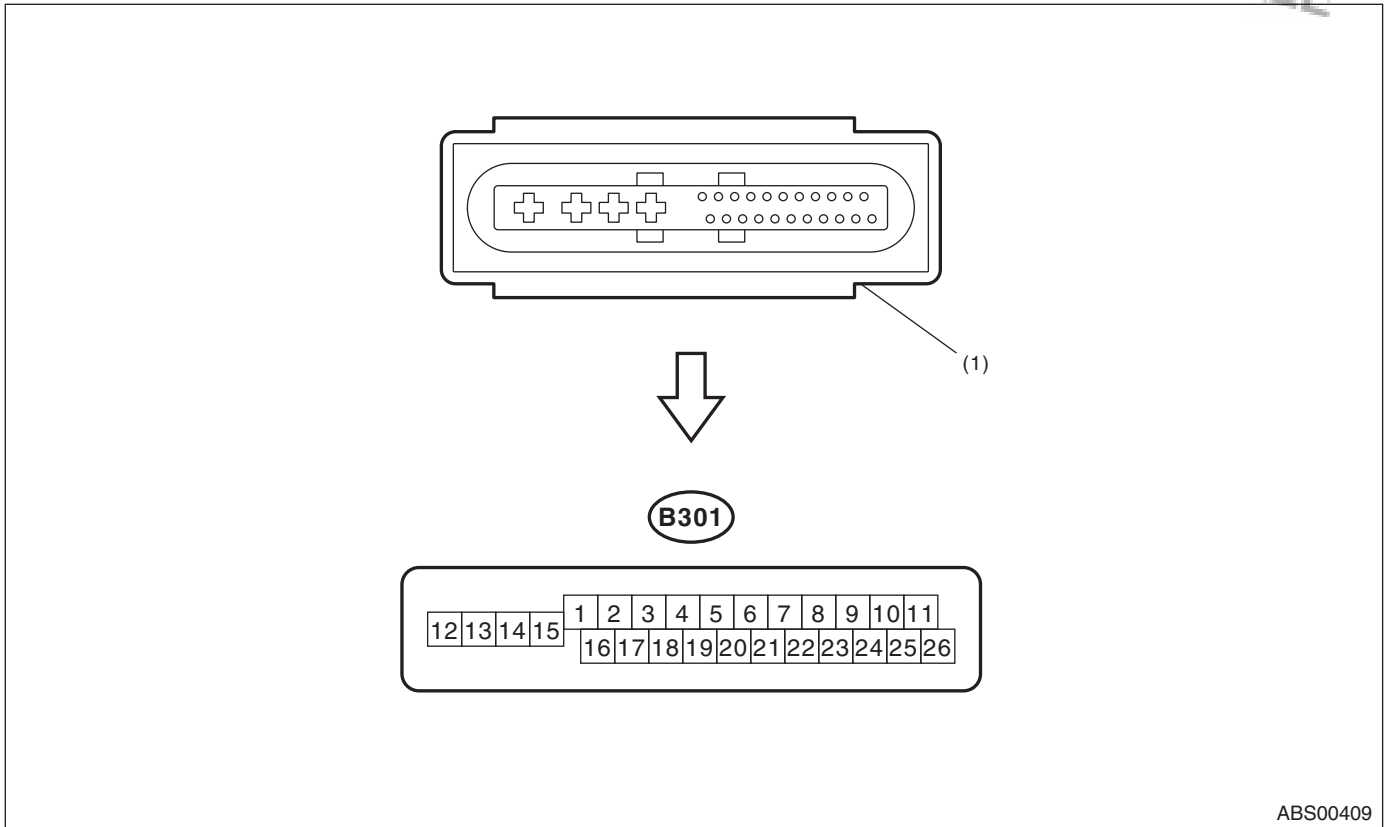

(1) ABS control module and hydraulic control unit (ABSCM&H/U) connector

NOTE:

- Terminal numbers in ABSCM&H/U connector are shown in the figure.
- ABS warning light illuminates when the connector is removed from ABSCM&H/U.

Control Module I/O Signal

ABS (DIAGNOSTICS)

Description			Terminal No. (+) — (-)	Input/Output signal
				Measured value and measuring conditions
ABS wheel speed sensor (Wheel speed sensor)	Front LH wheel	GND	16	—
		Signal	1 — 16	0.12 — 1 V (at 20 Hz)
	Front RH wheel	GND	5	—
		Signal	6 — 5	0.12 — 1 V (at 20 Hz)
	Rear LH wheel	GND	2	—
		Signal	3 — 2	0.12 — 1 V (at 20 Hz)
	Rear RH wheel	GND	4	—
		Signal	19 — 4	0.12 — 1 V (at 20 Hz)
CAN communication line (+)			26	2.5 — 1.5 V pulse signal
CAN communication line (-)			11	3.5 — 2.5 V pulse signal
Valve relay power supply *1			14 — 15	10 — 15 V
Motor relay power supply *1			13 — 15	10 — 15 V
G sensor	Power supply		24 — 10	4.75 — 5.25 V
	Ground		10	—
	Output		21 — 10	2.1 — 2.5 V when the vehicle is on level surface
Stop light switch *1			20 — 15	1.5 V or less when the stop light is OFF; otherwise, 10 — 15 V when the stop light is ON.
ABS warning light			22 — 15	After turning the ignition switch to ON, 10 — 15 V during 1.5 seconds and 1.5 V or less after 1.5 seconds passed.
Brake warning light (EBD warning light)			8 — 15	After turning the ignition switch to ON, 10 — 15 V during 1.5 seconds and 1.5 V or less after 1.5 seconds passed.
Subaru Select Monitor			7 — 15	1.5 V or less when no data is received. 0 ↔ 12 V pulse (in communication)
Power supply *1			18 — 15	10 — 15 V when the ignition switch is ON.
Grounding line			12	—
Grounding line			15	—

*1: Measure the I/O signal voltage after removing the connector from the ABSCM&H/U terminal.

B: WIRING DIAGRAM

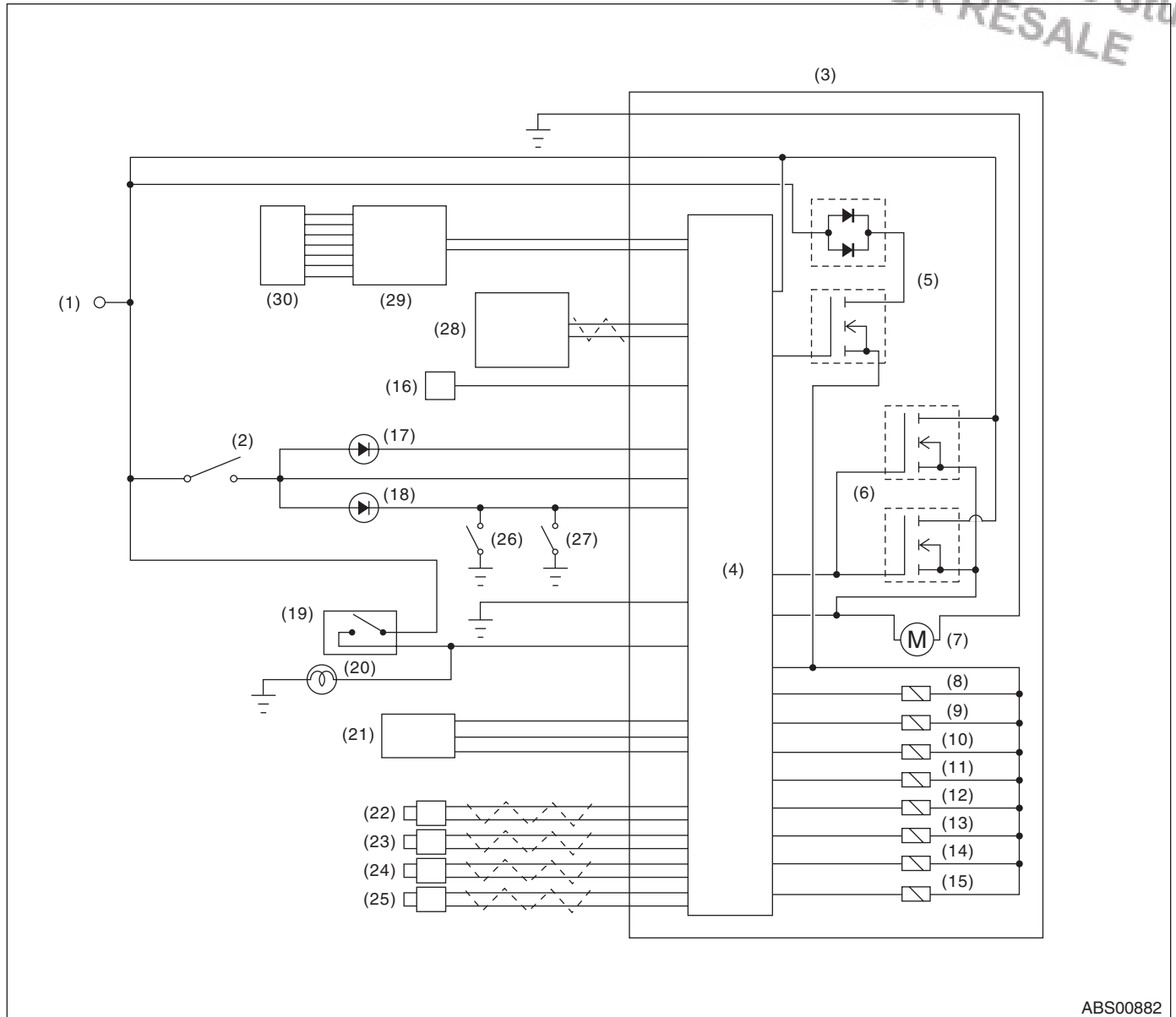

ABS00882

- | | | |
|---|--------------------------------------|--|
| (1) Battery | (13) Rear outlet solenoid valve LH | (24) Rear ABS wheel speed sensor LH |
| (2) Ignition switch | (14) Rear inlet solenoid valve RH | (25) Rear ABS wheel speed sensor RH |
| (3) ABS control module and hydraulic control unit (ABSCM&H/U) | (15) Rear outlet solenoid valve RH | (26) Parking brake switch |
| (4) ABS control module | (16) Data link connector | (27) Brake fluid level switch |
| (5) Valve relay | (17) ABS warning light | (28) Transmission control module (AT model) |
| (6) Motor relay | (18) Brake warning light | (29) Driver's control center differential control module (STI model) |
| (7) Motor | (19) Stop light switch | (30) Yaw rate & lateral G sensor (STI model) |
| (8) Front inlet solenoid valve LH | (20) Stop light | |
| (9) Front outlet solenoid valve LH | (21) G sensor | |
| (10) Front inlet solenoid valve RH | (22) Front ABS wheel speed sensor LH | |
| (11) Front outlet solenoid valve RH | (23) Front ABS wheel speed sensor RH | |
| (12) Rear inlet solenoid valve LH | | |

C: WAVEFORM

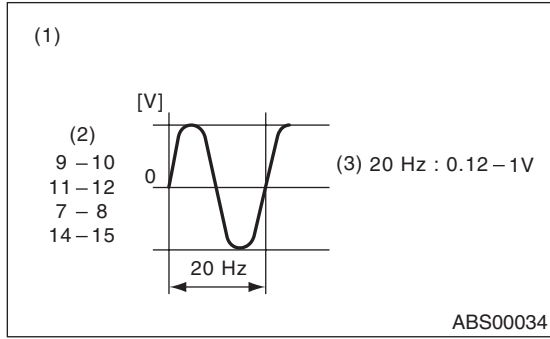

- (1) ABS wheel speed sensor
- (2) Terminal No.
- (3) Standard output voltage

6. Subaru Select Monitor

A: OPERATION

1. READ DIAGNOSTIC TROUBLE CODE (DTC)

- 1) Prepare the Subaru Select Monitor kit.
- 2) Connect the diagnosis cable to the Subaru Select Monitor.
- 3) Connect the Subaru Select Monitor to the data link connector.

(1) The data link connector is located in the lower portion of the instrument panel (on the driver's side).

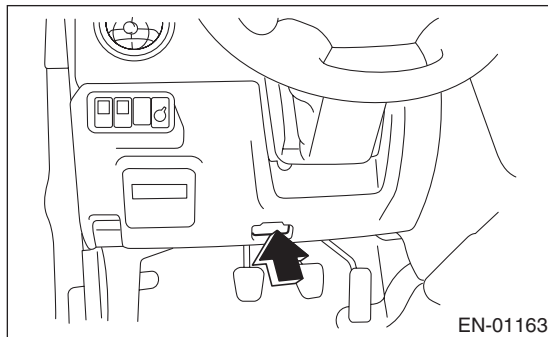

(2) Connect the diagnosis cable to the data link connector.

CAUTION:

Do not connect any scan tools except Subaru Select Monitor and general scan tool.

- 4) Turn the ignition switch to ON (engine OFF) and run the Subaru Select Monitor.
- 5) Select {Each System Check} in the «Main Menu» screen.
- 6) Select {Brake Control} in the «Selection Menu» screen.
- 7) Select [YES] after the information of engine type is displayed.
- 8) On the «ABS Diagnosis» screen, select {DTC Display}.
- 9) On the «Diagnostic Code(s) Display» screen, select {Current Diagnostic Code(s)} or {History Diagnostic Code(s)}.

NOTE:

- For details concerning the operation procedure, refer to the «SUBARU SELECT MONITOR OPERATION MANUAL».
- For details concerning DTCs, refer to List of Diagnostic Trouble Code (DTC). <Ref. to ABS(diag)-34, List of Diagnostic Trouble Code (DTC).>
- Up to 3 DTCs are displayed in the order of detection.

- If a particular DTC is not stored in memory properly at the occurrence of problem (due to a drop in ABSCM&H/U power supply etc.), the DTC suffixed with a question mark “?” is displayed on Subaru Select Monitor display screen. This shows it may be an unreliable reading.

Display	Contents to be monitored
Current	The current DTC is displayed on Subaru Select Monitor display screen.
Old	The latest DTC from the history of previous problems is displayed on Subaru Select Monitor display screen.
Older	The second latest DTC from the history of previous problems is displayed on the Subaru Select Monitor display screen.
Third previous	The third latest DTC from the history of previous problems is displayed on Subaru Select Monitor display screen.

Brought to you by Eris Studios
NOT FOR RESALE

2. READ CURRENT DATA

- 1) Select {Each System Check} in the «Main Menu» screen.
 - 2) Select {Brake Control} in the «Selection Menu» screen.
 - 3) Select [YES] after the information of ABS type is displayed.
 - 4) On the «Brake Control Diagnosis» display screen, select {Current Data Display/Save}.
 - 5) Select {Data Display} in the «Data Display Menu» screen.
 - 6) Using the scroll key, scroll the display screen up or down until necessary data is shown.
- A list of the support data is shown in the following table.

Display	Contents to be monitored	Unit of measure
FR Wheel Speed	Wheel speed detected by front ABS wheel speed sensor RH is displayed.	km/h or MPH
FL Wheel Speed	Wheel speed detected by front ABS wheel speed sensor LH is displayed.	km/h or MPH
RR Wheel Speed	Wheel speed detected by rear ABS wheel speed sensor RH is displayed.	km/h or MPH
RL Wheel Speed	Wheel speed detected by rear ABS wheel speed sensor LH is displayed.	km/h or MPH
Stop Light Switch	Stop light switch signal	ON or OFF
G Sensor Output Signal	Vehicle acceleration detected by analog G sensor is displayed.	m/s (m/s ²)
Lateral G sensor Output Signal	Vehicle lateral acceleration detected by lateral G sensor is displayed. (STI model)	m/s (m/s ²)
Valve Relay Signal	Valve relay operation signal is displayed.	ON or OFF
ABS Warning Light	ON operation of the ABS warning light is displayed.	ON or OFF
EBD Warning Light	ON operation of the EBD warning light is displayed.	ON or OFF
Motor Relay Monitor	Motor relay monitor voltage is displayed.	V
IG Power Supply Voltage	Voltage supplied to ABSCM&H/U is displayed.	V
ABS Control Flag	ABS control condition is displayed.	ON or OFF
ABS OK B Signal	ABS system normal/abnormal is displayed.	ON or OFF

NOTE:

For details concerning the operation procedure, refer to the “SUBARU SELECT MONITOR OPERATION MANUAL”.

3. CLEAR MEMORY MODE

- 1) On the «Main Menu» display screen, select {2. Each System Check}.
- 2) Select {Brake Control} in the «Selection Menu» screen.
- 3) Select [YES] after the information of engine type is displayed.
- 4) On the «Brake Control Diagnosis» display screen, select the {Clear Memory}.

Display	Contents to be monitored
Clear memory?	DTC deleting function

5) When the “Done” and “Turn Ignition Switch OFF” are shown on the display screen, turn the ignition switch to OFF, and terminate the Subaru Select Monitor.

NOTE:

For details concerning the operation procedure, refer to the “SUBARU SELECT MONITOR OPERATION MANUAL”.

4. ABS SEQUENCE CONTROL

Display	Contents to be monitored	Index No.
ABS sequence control	Operate the valve and pump motor continuously to perform the ABS sequence control.	<Ref. to ABS-10, ABS Sequence Control.>

5. FREEZE FRAME DATA

NOTE:

- Data stored at the time of trouble occurrence is shown on the display.
- Each time a trouble occurs, the latest information is stored in the freeze frame data in memory.
- Up to 3 freeze frame data will be stored.
- If a freeze frame data is not properly stored in memory (due to a drop in ABSCM power supply, etc.), a DTC suffixed with a question mark “?” appears on the Subaru Select Monitor display. This shows it may be an unreliable reading.

Display	Contents to be monitored
FR Wheel Speed	Wheel speed detected by the front ABS wheel speed sensor RH is displayed in km/h or mile/h.
FL Wheel Speed	Wheel speed detected by the front ABS wheel speed sensor LH is displayed in km/h or mile/h.
RR Wheel Speed	Wheel speed detected by the rear ABS wheel speed sensor RH is displayed in km/h or mile/h.
RL Wheel Speed	Wheel speed detected by the rear ABS wheel speed sensor LH is displayed in km/h or mile/h.
IG power supply voltage	Voltage supplied (V) to ABSCM&H/U is displayed on the Subaru Select Monitor.
G sensor output voltage	Voltage equivalent to vehicle acceleration detected by analog G sensor is displayed.
Lateral G sensor output voltage	Voltage equivalent to Lateral G detected by analog Lateral G sensor is displayed.
Motor Relay Monitor	Motor relay operation monitor signal
Stop Light Switch	Stop light switch signal
ABS operation signal	ABS operation signal
Power Supply Failure	Whether abnormal voltage occurred or not is displayed during malfunction.
Vehicle Speed	Vehicle speed is displayed.

Brought to you by Eris Studios
NOT FOR RESALE

B: INSPECTION

1. COMMUNICATION FOR INITIALIZING IMPOSSIBLE

DETECTING CONDITION:

Defective harness connector

TROUBLE SYMPTOM:

Communication is impossible between ABS and Subaru Select Monitor.

WIRING DIAGRAM:

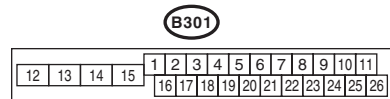
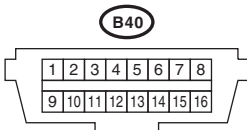
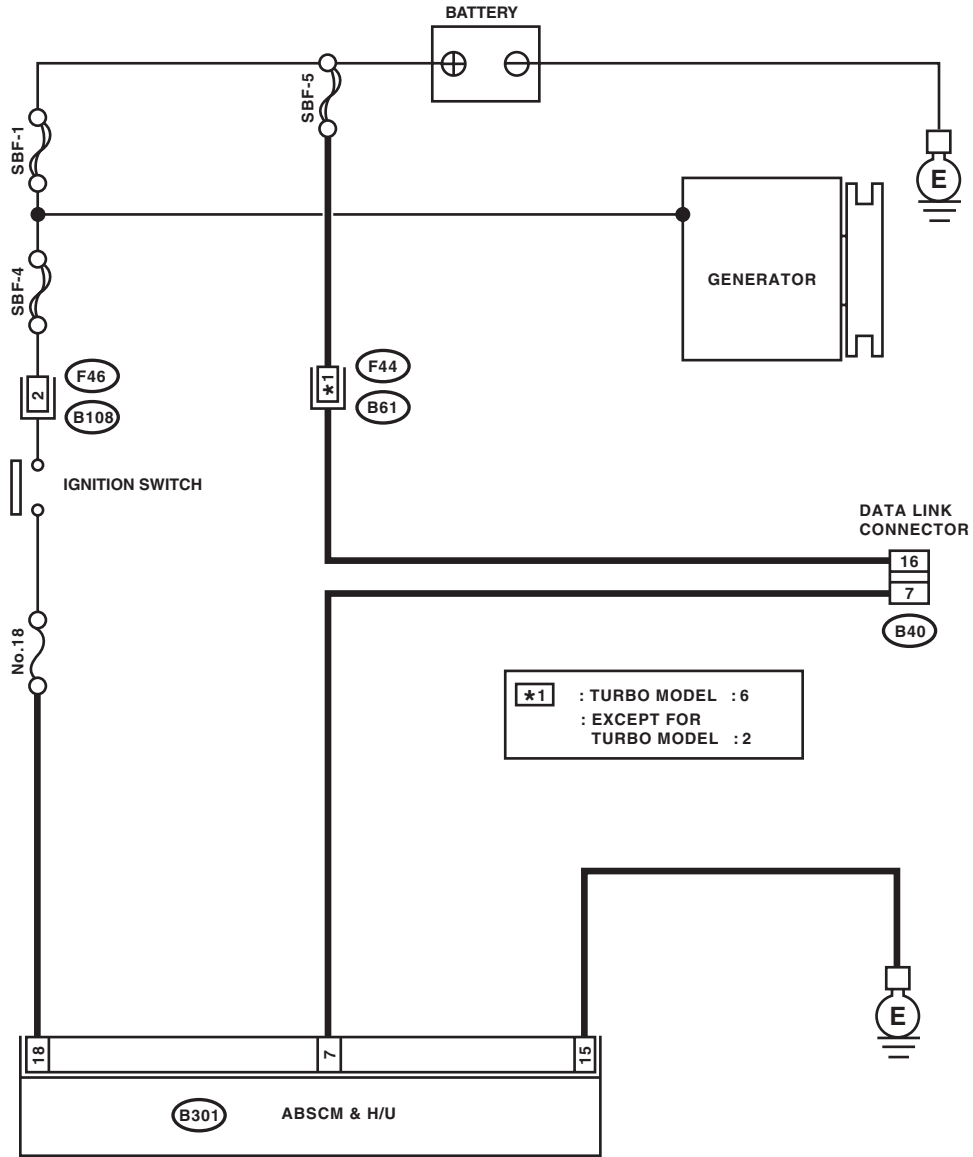

	Step	Check	Yes	No
1	CHECK IGNITION SWITCH.	Is the ignition switch turned to ON?	Go to step 2.	Turn the ignition switch to ON, and select ABS mode using Subaru Select Monitor.
2	CHECK BATTERY. 1) Turn the ignition switch to OFF. 2) Measure the battery voltage.	Is the voltage 11 V or more?	Go to step 3.	Charge or replace the battery.
3	CHECK BATTERY TERMINAL.	Is there poor contact at the battery terminal?	Repair or tighten the battery terminal.	Go to step 4.
4	CHECK SUBARU SELECT MONITOR COMMUNICATION. 1) Turn the ignition switch to ON. 2) Using the Subaru Select Monitor, check whether communication to other systems can be executed normally.	Are the system name and model year displayed on Subaru Select Monitor?	Go to step 8.	Go to step 5.
5	CHECK SUBARU SELECT MONITOR COMMUNICATION. 1) Turn the ignition switch to OFF. 2) Disconnect the ABSCM&H/U connectors. 3) Turn the ignition switch to ON. 4) Check whether communication to other systems can be executed normally.	Are the system name and model year displayed on Subaru Select Monitor?	Replace the ABSCM&H/U. <Ref. to ABS-6, ABS Control Module and Hydraulic Control Unit (ABSCM&H/U).>	Go to step 6.
6	CHECK HARNESS CONNECTOR BETWEEN EACH CONTROL MODULE AND DATA LINK CONNECTOR. 1) Turn the ignition switch to OFF. 2) Disconnect the ABSCM&H/U, ECM and TCM. 3) Measure the resistance between data link connector and chassis ground. Connector & terminal (B40) No. 7 — Chassis ground:	Is the resistance 1 M Ω or more?	Go to step 7.	Repair the harness and connector between each control module and data link connector.
7	CHECK OUTPUT SIGNAL FOR ABSCM&H/U. 1) Turn the ignition switch to ON. 2) Measure the voltage between ABSCM&H/U connector and chassis ground. Connector & terminal (B40) No. 7 (+) — Chassis ground (-):	Is the voltage less than 1 V?	Go to step 8.	Repair the harness and connector between each control module and data link connector.
8	CHECK HARNESS CONNECTOR BETWEEN ABSCM&H/U AND DATA LINK CONNECTOR. Measure the resistance between ABSCM&H/U connector and data link connector. Connector & terminal (B301) No. 7 — (B40) No. 7:	Is resistance less than 0.5 Ω ?	Go to step 9.	Repair harness and connector between ABSCM&H/U and data link connector.
9	CHECK INSTALLATION OF ABSCM&H/U CONNECTOR. Turn the ignition switch to OFF.	Is the ABSCM&H/U connector inserted into ABSCM&H/U until the clamp locks onto it?	Go to step 10.	Insert ABSCM&H/U connector into ABSCM&H/U.
10	CHECK POWER SUPPLY CIRCUIT. 1) Turn the ignition switch to ON (engine OFF). 2) Measure the ignition power supply voltage between ABSCM&H/U connector and chassis ground. Connector & terminal (B301) No. 18 (+) — Chassis ground (-):	Is the voltage 10 — 15 V?	Go to step 11.	Repair open circuit of harness between ABSCM&H/U and battery.

Subaru Select Monitor

ABS (DIAGNOSTICS)

Step	Check	Yes	No
11 CHECK HARNESS CONNECTOR BETWEEN ABSCM&H/U AND CHASSIS GROUND. 1) Turn the ignition switch to OFF. 2) Disconnect the ABSCM&H/U connectors and transmission connectors. 3) Measure the resistance of the harness between ABSCM&H/U and chassis ground. <i>Connector & terminal (B301) No. 15 — Chassis ground:</i>	Is resistance less than 0.5 Ω?	Go to step 12 .	Repair the open circuit of the harness between ABSCM&H/U and inhibitor side connector, and poor contact of coupling connector.
12 CHECK POOR CONTACT OF CONNECTOR.	Is there poor contact in the control module power supply, ground circuit and data link connector?	Repair the connector.	Replace the ABSCM&H/U. <Ref. to ABS-6, ABS Control Module and Hydraulic Control Unit (ABSCM&H/U).>

2. WITHOUT DTC

DETECTING CONDITION:

ABS warning light circuit is shorted.

TROUBLE SYMPTOM:

- ABS warning light does not go off.
- "NO TROUBLE CODE" will be displayed on the Subaru Select Monitor.

NOTE:

When the ABS warning light is OFF and "NO TROUBLE CODE" is displayed on Subaru Select Monitor, the system is in normal condition.

Subaru Select Monitor

ABS (DIAGNOSTICS)

WIRING DIAGRAM:

Brought to you by Eris Studios
NOT FOR RESALE

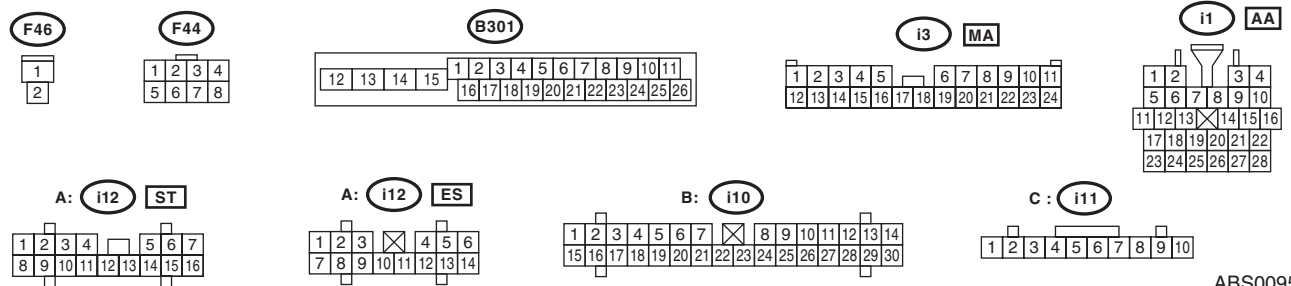
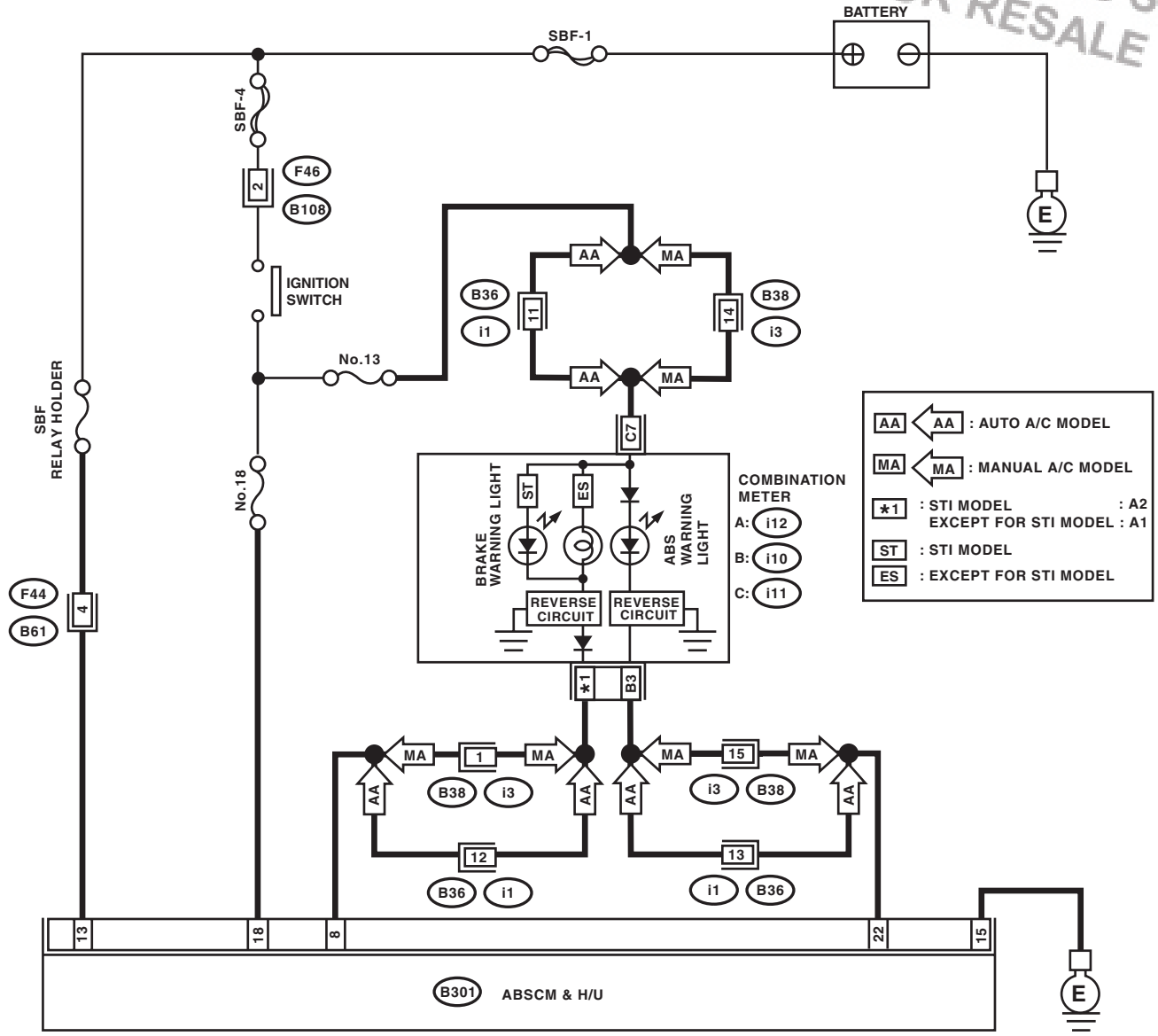

ABS00959

Subaru Select Monitor

ABS (DIAGNOSTICS)

Step	Check	Yes	No
1 CHECK SUBARU SELECT MONITOR DATA. 1) Select {Current Data Display & Save} in the Subaru Select Monitor. 2) Read the condition of "ABS warning light".	Is "ON" displayed?	Replace the ABSCM only. <Ref. to ABS-7, REPLACEMENT, ABS Control Module and Hydraulic Control Unit (ABSCM&H/U).>	Go to step 2.
2 CHECK WIRING HARNESS. Measure the resistance between ABSCM connector and combination meter connector. Connector & terminal <i>(i10) No. 3 — (B301) No. 22:</i>	Is resistance less than 0.5 Ω?	Go to step 3.	Repair harness and connector between ABSCM&H/U and combination meter.
3 CHECK POOR CONTACT OF CONNECTOR.	Is there poor contact in ABSCM connector and combination meter connector?	Repair the connector.	Check the combination meter.

Read Diagnostic Trouble Code (DTC)

ABS (DIAGNOSTICS)

7. Read Diagnostic Trouble Code (DTC)

A: OPERATION

For details concerning DTC, refer to the Subaru Select Monitor. <Ref. to ABS(diag)-15, Subaru Select Monitor.>

8. Inspection Mode

A: PROCEDURE

Reproduce the condition that the malfunction tends to occur as possible.

Drive the vehicle at a speed of 40 km/h (25 MPH) or more for at least one minute.

9. Clear Memory Mode

A: OPERATION

For details concerning DTC clear operation, refer to Subaru Select Monitor. <Ref. to ABS(diag)-15, Subaru Select Monitor.>

Brought to you by Eris Studios
NOT FOR RESALE

10. ABS Warning Light / Brake Warning Light Illumination Pattern

A: INSPECTION

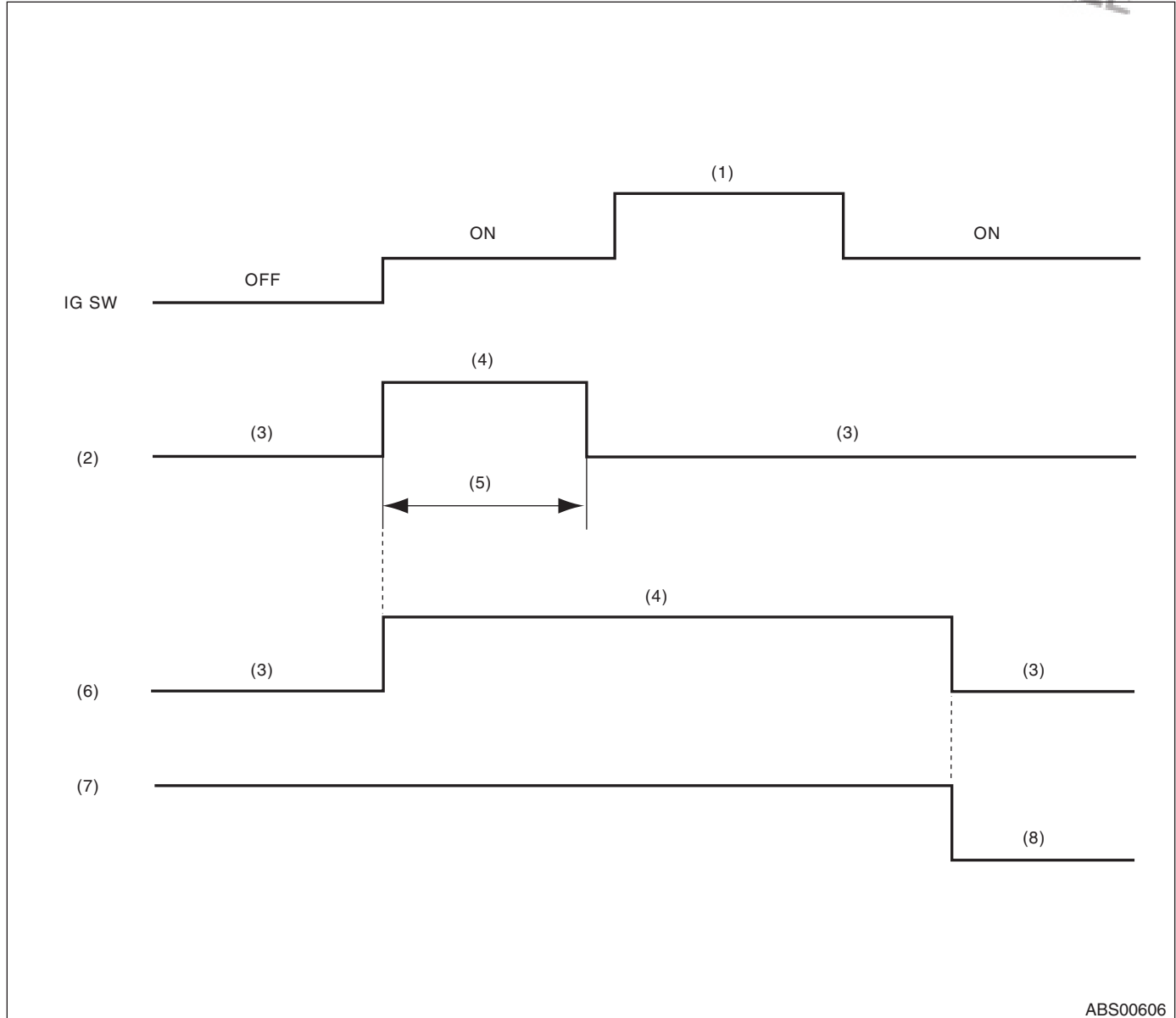

- | | | |
|-----------------------|--|-------------------|
| (1) Start | (5) Approx. 2 sec. | (7) Parking brake |
| (2) ABS warning light | (6) Brake warning light
(EBD warning light) | (8) Released |
| (3) Light OFF | | |
| (4) Light ON | | |

1) When the ABS warning light does not illuminate in accordance with this illumination pattern, it can be thought that there is an electrical problem.

2) When the ABS warning light remains constantly OFF, repair the ABS warning light circuit or diagnosis circuit.

NOTE:

Even though the ABS warning light does not go off after 2 seconds from ABS warning light illumination, the ABS system operates normally when the warning light goes off while driving at approximately 12 km/h (7 MPH). However, the anti-lock brake system does not work while the ABS warning light is illuminated.

ABS Warning Light / Brake Warning Light Illumination Pattern

ABS (DIAGNOSTICS)

Step	Check	Yes	No
1 CHECK ILLUMINATION OF OTHER LIGHTS. Turn the ignition switch to ON. (engine OFF)	Do other warning lights illuminate?	Go to step 2.	Check the combination meter.
2 READ DTC. Read the DTC. <Ref. to ABS(diag)-24, Read Diagnostic Trouble Code (DTC).>	Is DTC displayed?	Perform the diagnosis according to DTC.	Go to step 3.
3 CHECK GROUND SHORT OF HARNESS. 1) Turn the ignition OFF. 2) Disconnect the ABSCM&H/U connectors. 3) Disconnect the connector from the combination meter. 4) Measure the resistance between ABSCM connector and chassis ground. Connector & terminal (B301) No. 22 — Chassis ground:	Is the resistance 1 MΩ or more?	Go to step 4.	Repair harness and connector between ABSCM&H/U and combination meter.
4 CHECK ABSCM. 1) Connect the connector to the ABSCM&H/U. 2) Turn the ignition to ON. 3) Measure the resistance between the combination meter connector and chassis ground soon after the ignition switch is turned to ON (within 1.5 seconds). Connector & terminal (i10) No. 3 — Chassis ground:	Is the resistance 1 MΩ or more?	Check the combination meter.	Replace the ABSCM only. <Ref. to ABS-7, REPLACEMENT, ABS Control Module and Hydraulic Control Unit (ABSCM&H/U).>

ABS Warning Light / Brake Warning Light Illumination Pattern

ABS (DIAGNOSTICS)

C: ABS WARNING LIGHT DOES NOT GO OFF

DETECTING CONDITION:

- Defective combination meter
- Open circuit of harness

TROUBLE SYMPTOM:

When starting the engine, the ABS warning light is kept on.

WIRING DIAGRAM:

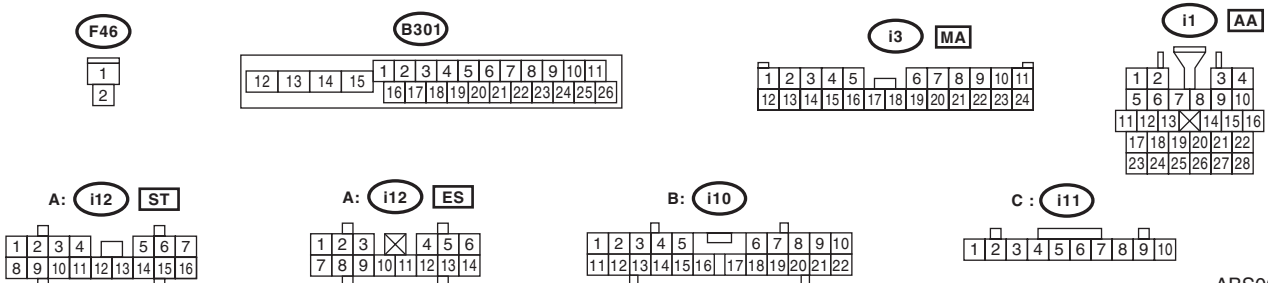
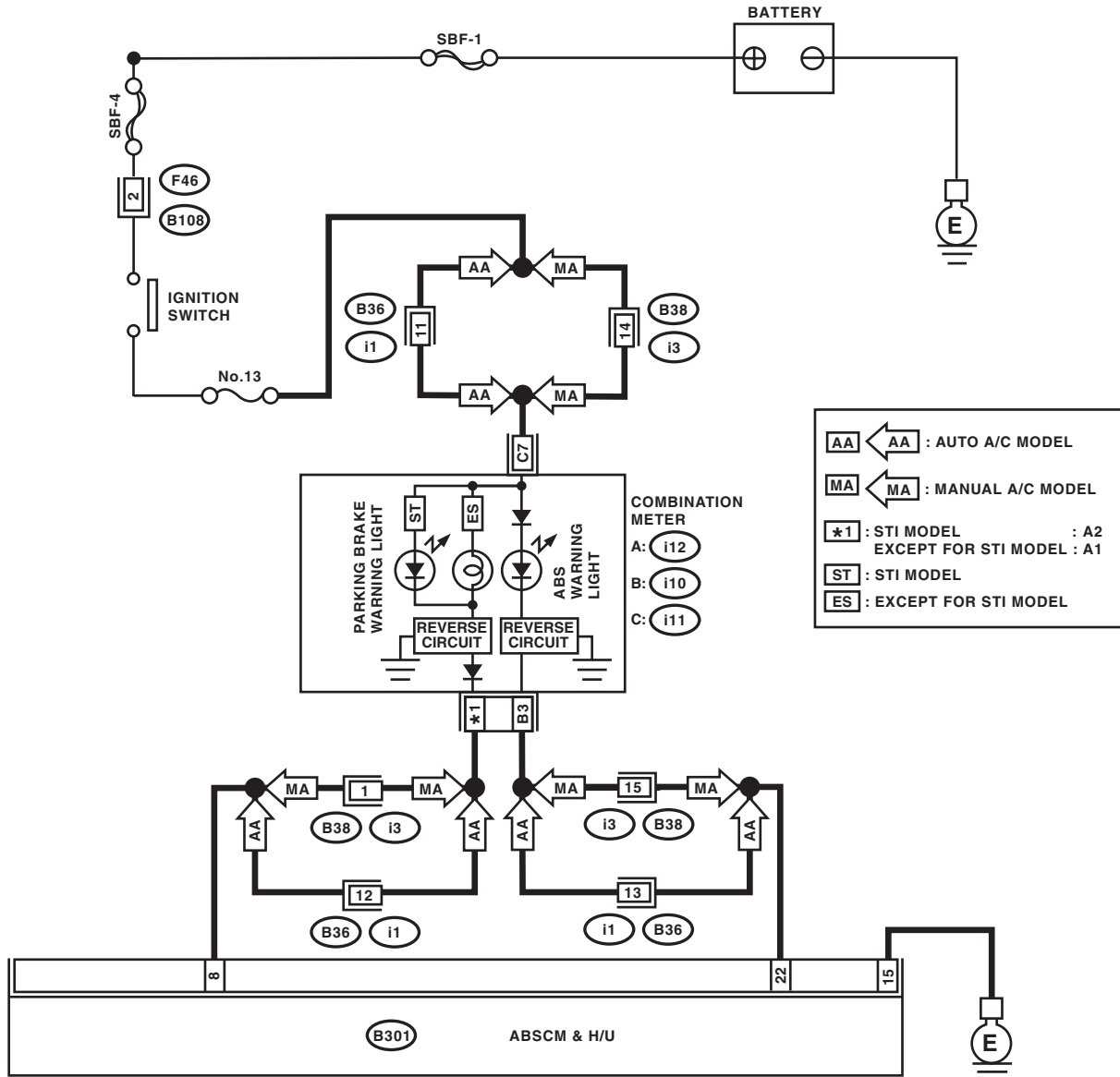

ABS00834

ABS Warning Light / Brake Warning Light Illumination Pattern

ABS (DIAGNOSTICS)

	Step	Check	Yes	No
1	READ DTC. Read the DTC. <Ref. to ABS(diag)-24, Read Diagnostic Trouble Code (DTC).>	Is DTC displayed?	Perform the diagnosis according to DTC.	Go to step 2.
2	CHECK WIRING HARNESS. 1) Turn the ignition OFF. 2) Disconnect the ABSCM&H/U connectors. 3) Disconnect the connector from the combination meter. 4) Measure the resistance between ABSCM connector and combination meter connector. Connector & terminal (B301) No. 22 — (i10) No. 3:	Is resistance less than 0.5 Ω?	Go to step 3.	Repair harness and connector between ABSCM&H/U and combination meter.
3	CHECK POOR CONTACT OF CONNECTOR. Check for poor contact of all connectors.	Is there poor contact?	Repair the connector.	Go to step 4.
4	CHECK ABSCM. 1) Connect the connector to the ABSCM&H/U. 2) Turn the ignition switch to ON. 3) Measure the resistance between combination meter connector and chassis ground. Connector & terminal (i10) No. 3 — Chassis ground:	Is resistance less than 0.5 Ω?	Check the combination meter.	Replace the ABSCM only. <Ref. to ABS-7, REPLACEMENT, ABS Control Module and Hydraulic Control Unit (ABSCM&H/U).>

ABS Warning Light / Brake Warning Light Illumination Pattern

ABS (DIAGNOSTICS)

D: BRAKE WARNING LIGHT DOES NOT GO OFF

DETECTING CONDITION:

- Brake warning light circuit is shorted.
- Defective sensor/connector

TROUBLE SYMPTOM:

After starting the engine, the brake warning light remains lit though the parking lever is released.

WIRING DIAGRAM:

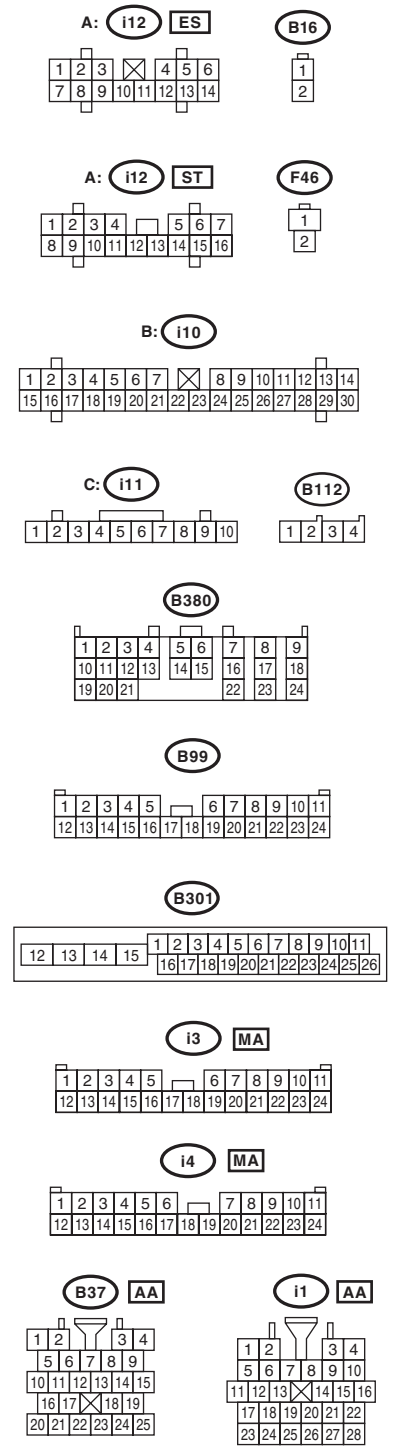
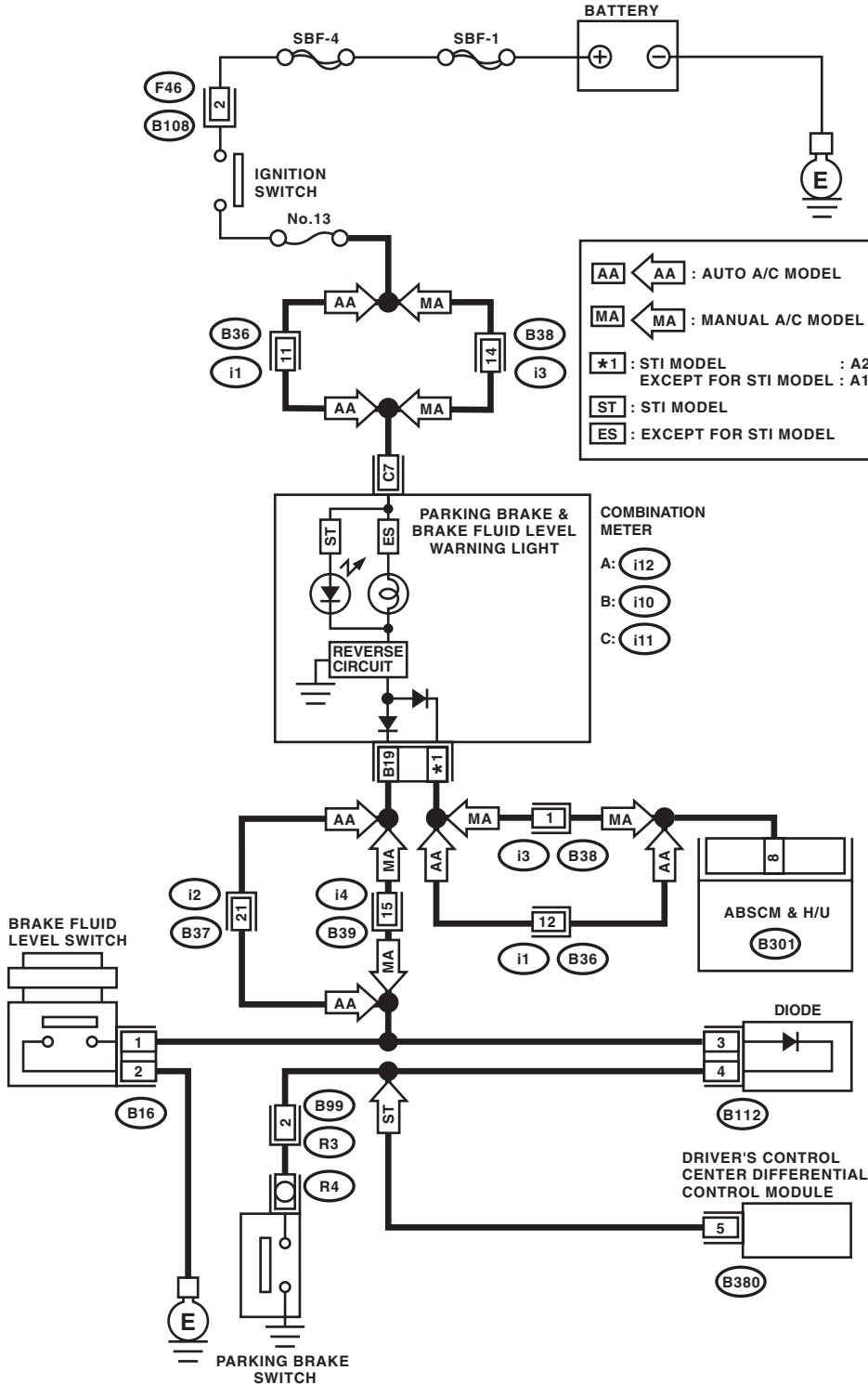

ABS00835

ABS Warning Light / Brake Warning Light Illumination Pattern

ABS (DIAGNOSTICS)

Step	Check	Yes	No
1 CHECK INSTALLATION OF ABSCM&H/U CONNECTOR. 1) Turn the ignition switch to OFF. 2) Check that the ABSCM&H/U connector is inserted to ABSCM&H/U until the clamp locks onto it.	Is the connector firmly inserted?	Go to step 2.	Insert the ABSCM&H/U connector until the clamp locks completely.
2 READ DTC. Read the DTC. <Ref. to ABS(diag)-24, Read Diagnostic Trouble Code (DTC).>	Is DTC displayed?	Perform the diagnosis according to DTC.	Go to step 3.
3 CHECK BRAKE FLUID AMOUNT. Check the amount of brake fluid in the reservoir tank of the master cylinder.	Is the amount of brake fluid between the lines of "MAX" and "MIN"?	Go to step 4.	Replenish brake fluid to the specified value.
4 CHECK BRAKE FLUID LEVEL SWITCH. 1) Disconnect brake fluid level switch connector (B16) from the master cylinder. 2) Measure the resistance between brake fluid switch terminals. <i>Terminals</i> <i>No. 1 — No. 2:</i>	Is the resistance 1 MΩ or more?	Go to step 5.	Replace the master cylinder.
5 CHECK PARKING BRAKE SWITCH. 1) Disconnect the connector (R4) from parking brake switch. 2) Release the parking brake. 3) Measure the resistance between parking brake switch terminal and chassis ground.	Is the resistance 1 MΩ or more?	Go to step 6.	Replace the parking brake switch.
6 CHECK GROUND SHORT OF HARNESS. 1) Disconnect the connector from the combination meter. 2) Measure the resistance between combination meter connector and chassis ground. <i>Connector & terminal</i> <i>(i10) No. 19 — Chassis ground:</i>	Is the resistance 1 MΩ or more?	Go to step 7.	Repair the harness connector between combination meter and parking brake switch.
7 CHECK HARNESS. 1) Disconnect the ABSCM&H/U connectors. 2) Disconnect the connector from the combination meter. 3) Measure the resistance between the ABSCM&H/U connector and combination meter connector. <i>Connector & terminal</i> <i>(B301) No. 8 — (i12) No. 1:</i>	Is resistance less than 0.5 Ω?	Go to step 8.	Repair the harness between the ABSCM&H/U and the combination meter.
8 CHECK POOR CONTACT OF CONNECTOR. Check for poor contact of all connectors.	Is there poor contact?	Repair the connector.	Go to step 9.
9 CHECK ABSCM. 1) Connect the connector to the ABSCM&H/U. 2) Turn the ignition switch to ON. 3) Measure the resistance between combination meter connector and chassis ground. <i>Connector & terminal</i> <i>(i12) No. 1 — Chassis ground:</i>	Is resistance less than 0.5 Ω?	Check the combination meter.	Replace the ABSCM only. <Ref. to ABS-7, REPLACEMENT, ABS Control Module and Hydraulic Control Unit (ABSCM&H/U).>

List of Diagnostic Trouble Code (DTC)

ABS (DIAGNOSTICS)

11. List of Diagnostic Trouble Code (DTC)

A: LIST

DTC	Display	Content of diagnosis	Reference target
—	Communication for initializing impossible	Subaru Select Monitor communication failure	<Ref. to ABS(diag)-18, COMMUNICATION FOR INITIALIZING IMPOSSIBLE, INSPECTION, Subaru Select Monitor.>
—	No DTC	Although no DTC appears on the Subaru Select Monitor display, the ABS warning light remains on.	<Ref. to ABS(diag)-21, WITHOUT DTC, INSPECTION, Subaru Select Monitor.>
21	Open or short circuit in Front ABS wheel speed sensor RH circuit	Open or Short Circuit in Front ABS Wheel Speed Sensor RH Circuit	<Ref. to ABS(diag)-36, DTC 21 OPEN OR SHORT CIRCUIT IN FRONT RIGHT ABS WHEEL SPEED SENSOR CIRCUIT, Diagnostic Procedure with Diagnostic Trouble Code (DTC).>
22	Front ABS wheel speed sensor RH abnormal signal	Front ABS wheel speed sensor RH abnormal signal	<Ref. to ABS(diag)-41, DTC 22 FRONT RIGHT ABNORMAL ABS WHEEL SPEED SENSOR SIGNAL, Diagnostic Procedure with Diagnostic Trouble Code (DTC).>
23	Open or short circuit in Front ABS wheel speed sensor LH circuit	Open or Short Circuit in Front Left ABS Wheel Speed Sensor Circuit	<Ref. to ABS(diag)-36, DTC 23 OPEN OR SHORT CIRCUIT IN FRONT LEFT ABS WHEEL SPEED SENSOR CIRCUIT, Diagnostic Procedure with Diagnostic Trouble Code (DTC).>
24	Front ABS wheel speed sensor LH abnormal signal	Front ABS wheel speed sensor LH abnormal signal	<Ref. to ABS(diag)-41, DTC 24 FRONT LEFT ABNORMAL ABS WHEEL SPEED SENSOR SIGNAL, Diagnostic Procedure with Diagnostic Trouble Code (DTC).>
25	Open or short circuit in Rear ABS wheel speed sensor RH circuit	Open or short circuit in Rear ABS wheel speed sensor RH circuit	<Ref. to ABS(diag)-36, DTC 25 OPEN OR SHORT CIRCUIT IN REAR RIGHT ABS WHEEL SPEED SENSOR CIRCUIT, Diagnostic Procedure with Diagnostic Trouble Code (DTC).>
26	Rear ABS wheel speed sensor RH abnormal signal	Rear ABS wheel speed sensor RH abnormal signal	<Ref. to ABS(diag)-41, DTC 26 REAR RIGHT ABNORMAL ABS WHEEL SPEED SENSOR SIGNAL, Diagnostic Procedure with Diagnostic Trouble Code (DTC).>
27	Open or short circuit in Rear ABS wheel speed sensor LH circuit	Open or short circuit in Rear ABS wheel speed sensor LH circuit	<Ref. to ABS(diag)-37, DTC 27 OPEN OR SHORT CIRCUIT IN REAR LEFT ABS WHEEL SPEED SENSOR CIRCUIT, Diagnostic Procedure with Diagnostic Trouble Code (DTC).>
28	Rear ABS wheel speed sensor LH abnormal signal	Rear ABS wheel speed sensor LH abnormal signal	<Ref. to ABS(diag)-42, DTC 28 REAR LEFT ABNORMAL ABS WHEEL SPEED SENSOR SIGNAL, Diagnostic Procedure with Diagnostic Trouble Code (DTC).>
29	Abnormal ABS wheel speed sensor signal on any one of four sensor	Abnormal ABS wheel speed sensor signal on any one of four	<Ref. to ABS(diag)-47, DTC 29 ABNORMAL ABS WHEEL SPEED SENSOR SIGNAL ON ANY ONE OF FOUR SENSOR, Diagnostic Procedure with Diagnostic Trouble Code (DTC).>
31	Front inlet valve RH malfunction	Front inlet valve RH malfunction	<Ref. to ABS(diag)-50, DTC 31 FRONT RIGHT INLET VALVE MALFUNCTION, Diagnostic Procedure with Diagnostic Trouble Code (DTC).>
32	Front outlet valve RH malfunction	Front outlet valve RH malfunction	<Ref. to ABS(diag)-53, DTC 32 FRONT RIGHT OUTLET VALVE MALFUNCTION, Diagnostic Procedure with Diagnostic Trouble Code (DTC).>
33	Front inlet valve LH malfunction	Front inlet valve LH malfunction	<Ref. to ABS(diag)-50, DTC 33 FRONT LEFT INLET VALVE MALFUNCTION, Diagnostic Procedure with Diagnostic Trouble Code (DTC).>
34	Front outlet valve LH malfunction	Front outlet valve LH malfunction	<Ref. to ABS(diag)-53, DTC 34 FRONT LEFT OUTLET VALVE MALFUNCTION, Diagnostic Procedure with Diagnostic Trouble Code (DTC).>
35	Rear inlet valve RH malfunction	Rear inlet valve RH malfunction	<Ref. to ABS(diag)-50, DTC 35 REAR RIGHT INLET VALVE MALFUNCTION, Diagnostic Procedure with Diagnostic Trouble Code (DTC).>

List of Diagnostic Trouble Code (DTC)

ABS (DIAGNOSTICS)

DTC	Display	Content of diagnosis	Reference target
36	Rear outlet valve RH malfunction	Rear outlet valve RH malfunction	<Ref. to ABS(diag)-53, DTC 36 REAR RIGHT OUTLET VALVE MALFUNCTION, Diagnostic Procedure with Diagnostic Trouble Code (DTC).>
37	Rear inlet valve LH malfunction	Rear inlet valve LH malfunction	<Ref. to ABS(diag)-51, DTC 37 REAR LEFT INLET VALVE MALFUNCTION, Diagnostic Procedure with Diagnostic Trouble Code (DTC).>
38	Rear outlet valve LH malfunction	Rear outlet valve LH malfunction	<Ref. to ABS(diag)-54, DTC 38 REAR LEFT OUTLET VALVE MALFUNCTION, Diagnostic Procedure with Diagnostic Trouble Code (DTC).>
41	ABS control module malfunction	ABSCM&H/U	<Ref. to ABS(diag)-57, DTC 41 ABS CONTROL MODULE MALFUNCTION, Diagnostic Procedure with Diagnostic Trouble Code (DTC).>
42	Power supply voltage Failure	Power voltage malfunction	<Ref. to ABS(diag)-59, DTC 42 POWER VOLTAGE MALFUNCTION, Diagnostic Procedure with Diagnostic Trouble Code (DTC).>
47	Improper CAN Communication	CAN communication circuit failure	<Ref. to ABS(diag)-62, DTC 47 IMPROPER CAN COMMUNICATION, Diagnostic Procedure with Diagnostic Trouble Code (DTC).>
51	Valve relay malfunction	Valve relay malfunction	<Ref. to ABS(diag)-66, DTC 51 VALVE RELAY MALFUNCTION, Diagnostic Procedure with Diagnostic Trouble Code (DTC).>
52	Motor and motor Relay	Motor/motor relay malfunction	<Ref. to ABS(diag)-68, DTC 52 MOTOR/MOTOR RELAY MALFUNCTION, Diagnostic Procedure with Diagnostic Trouble Code (DTC).>
54	Stop light switch signal circuit malfunction	Stop light switch signal circuit malfunction	<Ref. to ABS(diag)-71, DTC 54 STOP LIGHT SWITCH SIGNAL CIRCUIT MALFUNCTION, Diagnostic Procedure with Diagnostic Trouble Code (DTC).>
56	G sensor Failure	G sensor output voltage or output signal malfunction	<Ref. to ABS(diag)-73, DTC 56 G SENSOR OUTPUT VOLTAGE OR OUTPUT SIGNAL MALFUNCTION, Diagnostic Procedure with Diagnostic Trouble Code (DTC).>
73	Lateral G sensor Failure	Lateral G sensor output voltage or output signal malfunction	<Ref. to ABS(diag)-76, DTC 73 LATERAL G SENSOR OUTPUT VOLTAGE OR OUTPUT SIGNAL MALFUNCTION, Diagnostic Procedure with Diagnostic Trouble Code (DTC).>

Diagnostic Procedure with Diagnostic Trouble Code (DTC)

ABS (DIAGNOSTICS)

12. Diagnostic Procedure with Diagnostic Trouble Code (DTC)

A: DTC 21 OPEN OR SHORT CIRCUIT IN FRONT RIGHT ABS WHEEL SPEED SENSOR CIRCUIT

NOTE:

Refer to DTC 27 for the diagnostic procedure. <Ref. to ABS(diag)-37, DTC 27 OPEN OR SHORT CIRCUIT IN REAR LEFT ABS WHEEL SPEED SENSOR CIRCUIT, Diagnostic Procedure with Diagnostic Trouble Code (DTC).>

B: DTC 23 OPEN OR SHORT CIRCUIT IN FRONT LEFT ABS WHEEL SPEED SENSOR CIRCUIT

NOTE:

Refer to DTC 27 for the diagnostic procedure. <Ref. to ABS(diag)-37, DTC 27 OPEN OR SHORT CIRCUIT IN REAR LEFT ABS WHEEL SPEED SENSOR CIRCUIT, Diagnostic Procedure with Diagnostic Trouble Code (DTC).>

C: DTC 25 OPEN OR SHORT CIRCUIT IN REAR RIGHT ABS WHEEL SPEED SENSOR CIRCUIT

NOTE:

Refer to DTC 27 for the diagnostic procedure. <Ref. to ABS(diag)-37, DTC 27 OPEN OR SHORT CIRCUIT IN REAR LEFT ABS WHEEL SPEED SENSOR CIRCUIT, Diagnostic Procedure with Diagnostic Trouble Code (DTC).>

Diagnostic Procedure with Diagnostic Trouble Code (DTC)

ABS (DIAGNOSTICS)

D: DTC 27 OPEN OR SHORT CIRCUIT IN REAR LEFT ABS WHEEL SPEED SENSOR CIRCUIT

DIAGNOSIS:

- Defective ABS wheel speed sensor (broken wire, input voltage too high)
- Defective harness connector

TROUBLE SYMPTOM:

ABS does not operate.

WIRING DIAGRAM:

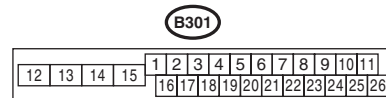
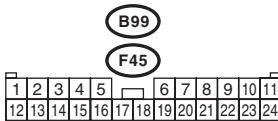
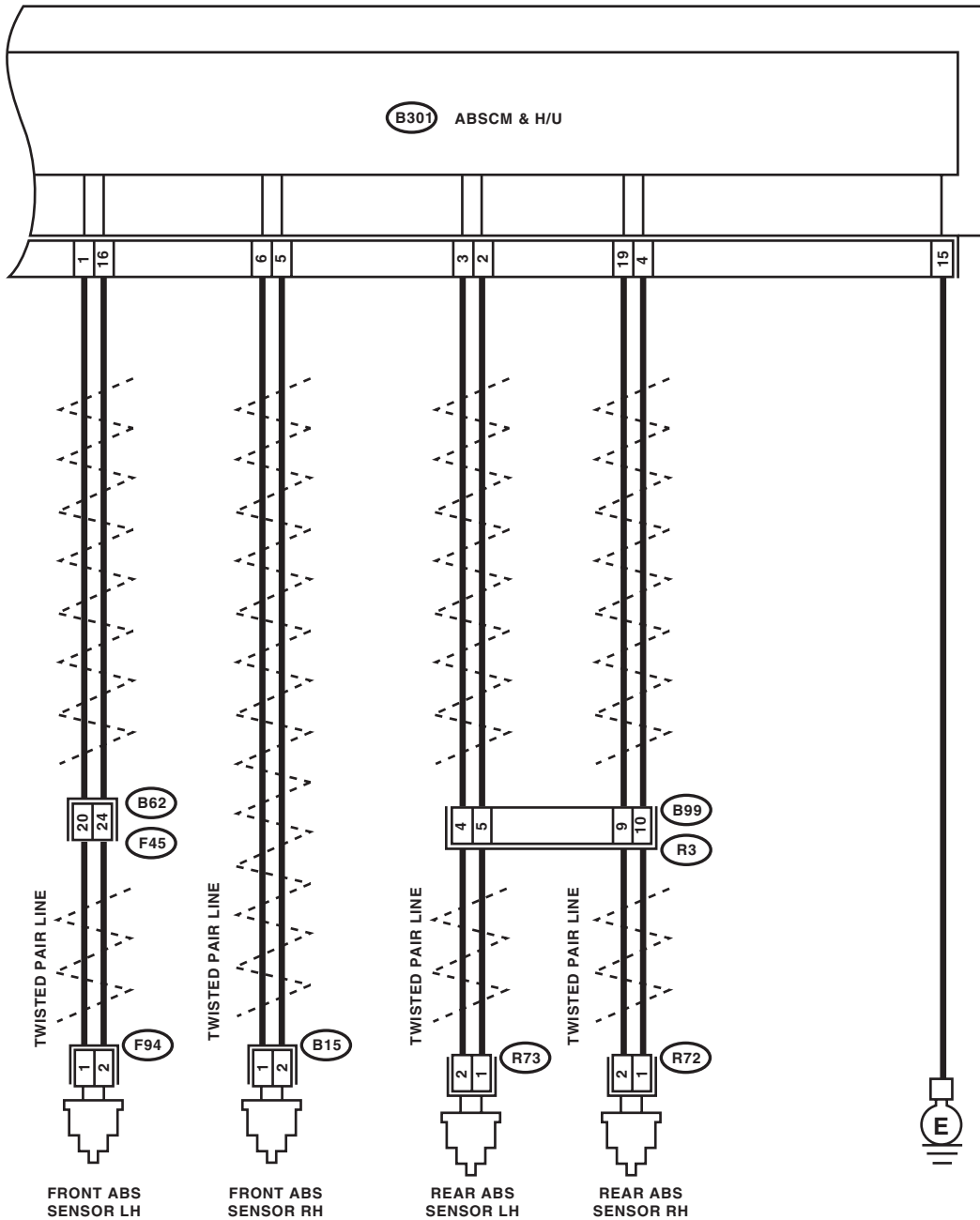

ABS00967

Diagnostic Procedure with Diagnostic Trouble Code (DTC)

ABS (DIAGNOSTICS)

Step	Check	Yes	No
1 CHECK OUTPUT OF ABS WHEEL SPEED SENSOR USING SUBARU SELECT MONITOR. 1) Select {Current Data Display & Save} in the Subaru Select Monitor. 2) Read the ABS wheel speed sensor output corresponding to the faulty system in Subaru Select Monitor display mode.	Does the speed indicated on the display change in response to the speedometer reading during acceleration or deceleration when the steering wheel is in the straight-ahead position?	Go to step 2.	Go to step 8.
2 CHECK INSTALLATION OF ABS WHEEL SPEED SENSOR.	Is the ABS wheel speed sensor installation bolt tightened 33 N·m (3.3 kgf-m, 24 ft-lb)?	Go to step 3.	Tighten the ABS wheel speed sensor installation bolts.
3 CHECK ABS WHEEL SPEED SENSOR GAP. Measure the gap between the ABS wheel speed sensor protrusion and tone wheel.	Is the gap within the following? Front wheel: 0.3 — 0.8 mm (0.012 — 0.031 in), Rear wheel: 0.7 — 1.2 mm (0.028 — 0.047 in)	Go to step 4.	Adjust the gap. NOTE: Adjust the gap using spacers (Part No. 26755AA000). If spacers cannot correct the gap, replace the worn sensor or worn tone wheel.
4 CHECK TONE WHEEL RUNOUT. Measure the tone wheel runout.	Is the runout less than 0.05 mm (0.0020 in)?	Go to step 5.	Replace the tone wheel. Front: <Ref. to ABS-18, Front Tone Wheel.> Rear: <Ref. to ABS-19, Rear Tone Wheel.>
5 CHECK POOR CONTACT OF CONNECTOR. Turn the ignition switch to OFF.	Is there poor contact in connectors between ABSCM&H/U and ABS wheel speed sensor?	Repair the connector.	Go to step 6.
6 CHECK ABSCM&H/U. 1) Connect all connectors. 2) Erase the memory. 3) Perform the Inspection Mode. 4) Read the DTC.	Is the same DTC still output?	Replace the ABSCM&H/U. <Ref. to ABS-6, ABS Control Module and Hydraulic Control Unit (ABSCM&H/U).>	Go to step 7.
7 CHECK OTHER DTC DETECTION.	Is there any other DTC detected?	Perform the diagnosis according to DTC.	Temporary poor contact occurs. NOTE: Check the harness and connector between ABSCM&H/U and ABS wheel speed sensor.
8 CHECK ABS WHEEL SPEED SENSOR. 1) Turn the ignition switch to OFF. 2) Disconnect the connector from the ABS wheel speed sensor. 3) Measure the resistance of ABS wheel speed sensor terminals while shaking the harness lightly. Terminals <i>Front RH No. 1 — No. 2:</i> <i>Front LH No. 1 — No. 2:</i> <i>Rear RH No. 1 — No. 2:</i> <i>Rear LH No. 1 — No. 2:</i>	Is the resistance within the following? Front: 1 — 1.5 kΩ, Rear: 1.025 — 1.265 kΩ	Go to step 9.	Replace the ABS wheel speed sensor. Front: <Ref. to ABS-13, Front ABS Wheel Speed Sensor.> Rear: <Ref. to ABS-16, Rear ABS Wheel Speed Sensor.>

Diagnostic Procedure with Diagnostic Trouble Code (DTC)

ABS (DIAGNOSTICS)

Step	Check	Yes	No
<p>9 CHECK BATTERY SHORT OF ABS WHEEL SPEED SENSOR. 1) Disconnect the ABSCM&H/U connectors. 2) Measure the voltage between ABS wheel speed sensor and chassis ground. Terminals <i>Front RH No. 1 (+) — Chassis ground (-):</i> <i>Front LH No. 1 (+) — Chassis ground (-):</i> <i>Rear RH No. 1 (+) — Chassis ground (-):</i> <i>Rear LH No. 1 (+) — Chassis ground (-):</i></p>	Is the voltage less than 1 V?	Go to step 10.	Replace the ABS wheel speed sensor. Front: <Ref. to ABS-13, Front ABS Wheel Speed Sensor.> Rear: <Ref. to ABS-16, Rear ABS Wheel Speed Sensor.>
<p>10 CHECK BATTERY SHORT OF ABS WHEEL SPEED SENSOR. 1) Turn the ignition switch to ON. 2) Measure the voltage between ABS wheel speed sensor and chassis ground. Terminals <i>Front RH No. 1 (+) — Chassis ground (-):</i> <i>Front LH No. 1 (+) — Chassis ground (-):</i> <i>Rear RH No. 1 (+) — Chassis ground (-):</i> <i>Rear LH No. 1 (+) — Chassis ground (-):</i></p>	Is the voltage less than 1 V?	Go to step 11.	Replace the ABS wheel speed sensor. Front: <Ref. to ABS-13, Front ABS Wheel Speed Sensor.> Rear: <Ref. to ABS-16, Rear ABS Wheel Speed Sensor.>
<p>11 CHECK HARNESS CONNECTOR BETWEEN ABSCM&H/U AND ABS WHEEL SPEED SENSOR. 1) Turn the ignition switch to OFF. 2) Connect the connector to the ABS wheel speed sensor. 3) Measure the resistance between ABSCM&H/U connector terminals. Connector & terminal DTC 21 <i>(B301) No. 6 — No. 5:</i> DTC 23 <i>(B301) No. 1 — No. 16:</i> DTC 25 <i>(B301) No. 19 — No. 4:</i> DTC 27 <i>(B301) No. 3 — No. 2:</i></p>	Is the resistance within the following? Front: 1 — 1.5 kΩ, Rear: 1.025 — 1.265 kΩ	Go to step 12.	Repair the harness connector between ABSCM&H/U and ABS wheel speed sensor.
<p>12 CHECK BATTERY SHORT OF HARNESS. Measure the voltage between ABSCM&H/U connector and chassis ground. Connector & terminal DTC 21 <i>(B301) No. 6 (+) — Chassis ground (-):</i> DTC 23 <i>(B301) No. 1 (+) — Chassis ground (-):</i> DTC 25 <i>(B301) No. 19 (+) — Chassis ground (-):</i> DTC 27 <i>(B301) No. 3 (+) — Chassis ground (-):</i></p>	Is the voltage less than 1 V?	Go to step 13.	Repair the harness between ABSCM&H/U and ABS wheel speed sensor.

Diagnostic Procedure with Diagnostic Trouble Code (DTC)

ABS (DIAGNOSTICS)

Step	Check	Yes	No
13 CHECK BATTERY SHORT OF HARNESS. 1) Turn the ignition switch to ON. 2) Measure the voltage between ABSCM&H/U connector and chassis ground. Connector & terminal DTC 21 <i>(B301) No. 6 (+) — Chassis ground (-):</i> DTC 23 <i>(B301) No. 1 (+) — Chassis ground (-):</i> DTC 25 <i>(B301) No. 19 (+) — Chassis ground (-):</i> DTC 27 <i>(B301) No. 3 (+) — Chassis ground (-):</i>	Is the voltage less than 1 V?	Go to step 14.	Repair the harness between ABSCM&H/U and ABS wheel speed sensor.
14 CHECK INSTALLATION OF ABS WHEEL SPEED SENSOR.	Is the ABS wheel speed sensor installation bolt tightened 33 N·m (3.3 kgf-m, 24 ft-lb)?	Go to step 15.	Tighten the ABS wheel speed sensor installation bolts.
15 CHECK ABS WHEEL SPEED SENSOR GAP. Measure the gap between the ABS wheel speed sensor protrusion and tone wheel.	Is the gap within the following? Front wheel: 0.3 — 0.8 mm (0.012 — 0.031 in), Rear wheel: 0.7 — 1.2 mm (0.028 — 0.047 in)	Go to step 16.	Adjust the gap. NOTE: Adjust the gap using spacers (Part No. 26755AA000). If spacers cannot correct the gap, replace the worn sensor or worn tone wheel.
16 CHECK TONE WHEEL RUNOUT. Measure the tone wheel runout.	Is the runout less than 0.05 mm (0.0020 in)?	Go to step 17.	Replace the tone wheel. Front: <Ref. to ABS-18, Front Tone Wheel.> Rear: <Ref. to ABS-19, Rear Tone Wheel.>
17 CHECK GROUND SHORT OF ABS WHEEL SPEED SENSOR. 1) Turn the ignition switch to ON. 2) Measure the resistance between ABS wheel speed sensor and chassis ground. Terminals Front RH No. 1 — Chassis ground: Front LH No. 1 — Chassis ground: Rear RH No. 1 — Chassis ground: Rear LH No. 1 — Chassis ground:	Is the resistance 1 MΩ or more?	Go to step 18.	Replace the ABSCM&H/U and ABS wheel speed sensor. Front: <Ref. to ABS-13, Front ABS Wheel Speed Sensor.> Rear: <Ref. to ABS-16, Rear ABS Wheel Speed Sensor.> and <Ref. to ABS-6, ABS Control Module and Hydraulic Control Unit (ABSCM&H/U).>

Diagnostic Procedure with Diagnostic Trouble Code (DTC)

ABS (DIAGNOSTICS)

Step	Check	Yes	No
18 CHECK GROUND SHORT OF HARNESS. 1) Turn the ignition switch to OFF. 2) Connect the connector to the ABS wheel speed sensor. 3) Measure the resistance between ABSCM&H/U connectors and chassis ground. Connector & terminal DTC 21 (B301) No. 6 — Chassis ground: DTC 23 (B301) No. 1 — Chassis ground: DTC 25 (B301) No. 19 — Chassis ground: DTC 27 (B301) No. 3 — Chassis ground:	Is the resistance 1 MΩ or more?	Go to step 19.	Repair the harness between ABSCM&H/U and ABS wheel speed sensor. Replace the ABSCM&H/U. <Ref. to ABS-6, ABS Control Module and Hydraulic Control Unit (ABSCM&H/U).>
19 CHECK POOR CONTACT OF CONNECTOR.	Is there poor contact in connectors between ABSCM&H/U and ABS wheel speed sensor?	Repair the connector.	Go to step 20.
20 CHECK ABSCM&H/U. 1) Connect all connectors. 2) Erase the memory. 3) Perform the Inspection Mode. 4) Read the DTC.	Is the same DTC still output?	Replace the ABSCM&H/U.	Go to step 21.
21 CHECK OTHER DTC DETECTION.	Is there any other DTC detected?	Perform the diagnosis according to DTC.	Temporary poor contact occurs. NOTE: Check the harness and connector between ABSCM&H/U and ABS wheel speed sensor.

E: DTC 22 FRONT RIGHT ABNORMAL ABS WHEEL SPEED SENSOR SIGNAL

NOTE:

Refer to DTC 28 for the diagnostic procedure. <Ref. to ABS(diag)-42, DTC 28 REAR LEFT ABNORMAL ABS WHEEL SPEED SENSOR SIGNAL, Diagnostic Procedure with Diagnostic Trouble Code (DTC).>

F: DTC 24 FRONT LEFT ABNORMAL ABS WHEEL SPEED SENSOR SIGNAL

NOTE:

Refer to DTC 28 for the diagnostic procedure. <Ref. to ABS(diag)-42, DTC 28 REAR LEFT ABNORMAL ABS WHEEL SPEED SENSOR SIGNAL, Diagnostic Procedure with Diagnostic Trouble Code (DTC).>

G: DTC 26 REAR RIGHT ABNORMAL ABS WHEEL SPEED SENSOR SIGNAL

NOTE:

Refer to DTC 28 for the diagnostic procedure. <Ref. to ABS(diag)-42, DTC 28 REAR LEFT ABNORMAL ABS WHEEL SPEED SENSOR SIGNAL, Diagnostic Procedure with Diagnostic Trouble Code (DTC).>

Diagnostic Procedure with Diagnostic Trouble Code (DTC)

ABS (DIAGNOSTICS)

H: DTC 28 REAR LEFT ABNORMAL ABS WHEEL SPEED SENSOR SIGNAL

DIAGNOSIS:

- Defective ABS wheel speed sensor signal (noise, abnormal signal, etc.)
- Defective harness connector

TROUBLE SYMPTOM:

ABS does not operate.

WIRING DIAGRAM:

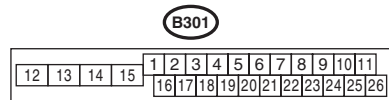
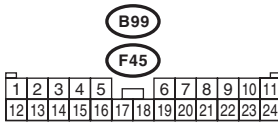
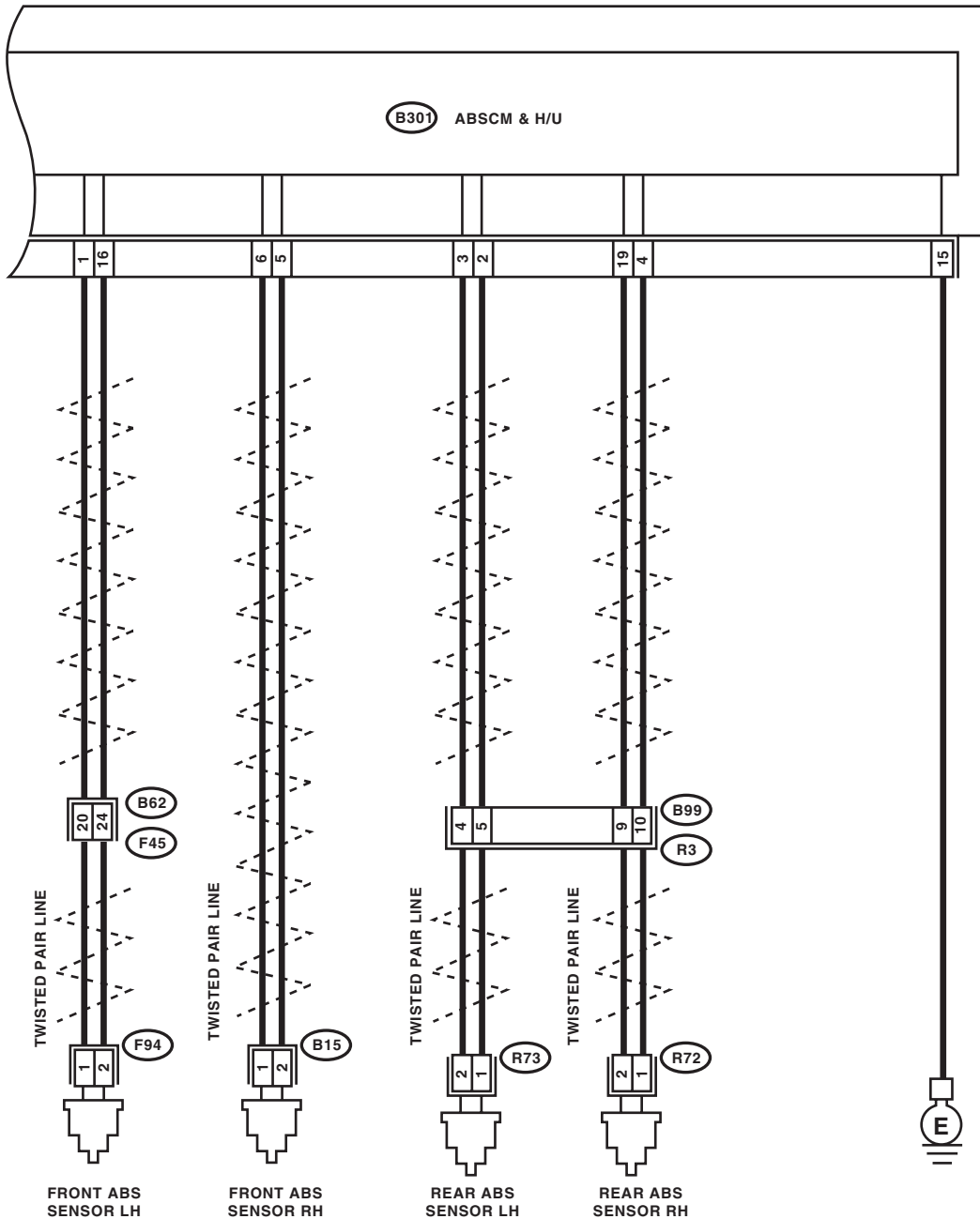

ABS00967

Diagnostic Procedure with Diagnostic Trouble Code (DTC)

ABS (DIAGNOSTICS)

	Step	Check	Yes	No
1	CHECK OUTPUT OF ABS WHEEL SPEED SENSOR USING SUBARU SELECT MONITOR. 1) Select {Current Data Display & Save} in the Subaru Select Monitor. 2) Read the ABS wheel speed sensor output corresponding to the faulty system in Subaru Select Monitor display mode.	Does the speed indicated on the display change in response to the speedometer reading during acceleration or deceleration when the steering wheel is in the straight-ahead position?	Go to step 2.	Go to step 7.
2	CHECK POOR CONTACT OF CONNECTOR. Turn the ignition switch to OFF.	Is there poor contact in connectors between ABSCM&H/U and ABS wheel speed sensor?	Repair the connector.	Go to step 3.
3	CHECK CAUSE OF SIGNAL NOISE.	Is the car telephone or the radio properly installed?	Go to step 4.	Install the car telephone or radio properly.
4	CHECK CAUSE OF SIGNAL NOISE.	Is there a noise source (such as an antenna) installed near the sensor harness?	Install the noise source apart from the sensor harness.	Go to step 5.
5	CHECK ABSCM&H/U. 1) Connect all connectors. 2) Erase the memory. 3) Perform the Inspection Mode. 4) Read the DTC.	Is the same DTC still output?	Replace the ABSCM&H/U. <Ref. to ABS-6, ABS Control Module and Hydraulic Control Unit (ABSCM&H/U).>	Go to step 6.
6	CHECK OTHER DTC DETECTION.	Is there any other DTC detected?	Perform the diagnosis according to DTC.	It results from a temporary noise interference.
7	CHECK INSTALLATION OF ABS WHEEL SPEED SENSOR.	Is the ABS wheel speed sensor installation bolt tightened 33 N·m (3.3 kgf-m, 24 ft-lb)?	Go to step 8.	Tighten the ABS wheel speed sensor installation bolts.
8	CHECK ABS WHEEL SPEED SENSOR GAP. Measure the gap between the ABS wheel speed sensor protrusion and tone wheel.	Is the gap within the following? Front wheel: 0.3 — 0.8 mm (0.012 — 0.031 in), Rear wheel: 0.7 — 1.2 mm (0.028 — 0.047 in)	Go to step 9.	Adjust the gap. NOTE: Adjust the gap using spacers (Part No. 26755AA000). If spacers cannot correct the gap, replace the worn sensor or worn tone wheel.
9	PREPARE OSCILLOSCOPE.	Is an oscilloscope available?	Go to step 10.	Go to step 11.

Diagnostic Procedure with Diagnostic Trouble Code (DTC)

ABS (DIAGNOSTICS)

Step	Check	Yes	No
10 CHECK ABS WHEEL SPEED SENSOR SIGNAL. 1) Lift up the vehicle. 2) Turn the ignition switch to OFF. 3) Connect the oscilloscope to the connector. 4) Turn the ignition switch to ON. 5) Start the wheel, and measure the voltage at the specified frequency. <Ref. to ABS(diag)-14, WAVEFORM, Control Module I/O Signal.> NOTE: When this inspection is completed, ABSCM&H/U may record DTC 29 or DTC 56. Connector & terminal DTC 22 (B15) No. 1 (+) — No. 2 (-): DTC 24 (B62) No. 20 (+) — No. 24 (-): DTC 26 (B99) No. 10 (+) — No. 9 (-): DTC 28 (B99) No. 5 (+) — No. 4 (-):	Is the oscilloscope pattern the same waveform as shown in the figure?	Go to step 14.	Go to step 11.
11 CHECK CONTAMINATION OF ABS WHEEL SPEED SENSOR OR TONE WHEEL. Remove the disc rotor or drum from the hub according to the DTC.	Is the ABS wheel speed sensor piece or the tone wheel contaminated by dirt or other foreign matter?	Thoroughly remove dirt or other foreign matter.	Go to step 12.
12 CHECK DAMAGE OF ABS WHEEL SPEED SENSOR OR TONE WHEEL.	Is there damage in the protrusion of the ABS wheel speed sensor or the tone wheel?	Go to step 13.	Replace the ABS wheel speed sensor or tone wheel. Front: <Ref. to ABS-13, Front ABS Wheel Speed Sensor.> Rear: <Ref. to ABS-16, Rear ABS Wheel Speed Sensor.> and front: <Ref. to ABS-18, Front Tone Wheel.> Rear: <Ref. to ABS-19, Rear Tone Wheel.>
13 CHECK TONE WHEEL RUNOUT. Measure the tone wheel runout.	Is the runout less than 0.05 mm (0.0020 in)?	Go to step 14.	Replace the tone wheel. Front: <Ref. to ABS-18, Front Tone Wheel.> Rear: <Ref. to ABS-19, Rear Tone Wheel.>

Diagnostic Procedure with Diagnostic Trouble Code (DTC)

ABS (DIAGNOSTICS)

Step	Check	Yes	No
<p>14 CHECK RESISTANCE OF THE ABS WHEEL SPEED SENSOR.</p> <p>1) Turn the ignition switch to OFF. 2) Disconnect the connector from the ABS wheel speed sensor. 3) Measure the resistance of the ABS wheel speed sensor connector terminals by shaking the harness lightly.</p> <p>Terminals Front RH No. 1 — No. 2: Front LH No. 1 — No. 2: Rear RH No. 1 — No. 2: Rear LH No. 1 — No. 2:</p>	<p>Is the resistance within the following? Front: 1 — 1.5 kΩ, Rear: 1.025 — 1.265 kΩ</p>	Go to step 15.	<p>Replace the ABS wheel speed sensor. Front: <Ref. to ABS-13, Front ABS Wheel Speed Sensor.> Rear: <Ref. to ABS-16, Rear ABS Wheel Speed Sensor.></p>
<p>15 CHECK GROUND SHORT OF ABS WHEEL SPEED SENSOR.</p> <p>Measure the resistance between ABS wheel speed sensor and chassis ground.</p> <p>Terminals Front RH No. 1 — Chassis ground: Front LH No. 1 — Chassis ground: Rear RH No. 1 — Chassis ground: Rear LH No. 1 — Chassis ground:</p>	<p>Is the resistance 1 MΩ or more?</p>	Go to step 16.	<p>Replace the ABS wheel speed sensor. Front: <Ref. to ABS-13, Front ABS Wheel Speed Sensor.> Rear: <Ref. to ABS-16, Rear ABS Wheel Speed Sensor.></p>
<p>16 CHECK HARNESS CONNECTOR BETWEEN ABSCM&H/U AND ABS WHEEL SPEED SENSOR.</p> <p>1) Connect the connector to the ABS wheel speed sensor. 2) Disconnect the ABSCM&H/U connectors. 3) Measure the resistance between ABSCM&H/U connector terminals.</p> <p>Connector & terminal DTC 22 (B301) No. 6 — No. 5: DTC 24 (B301) No. 1 — No. 16: DTC 26 (B301) No. 19 — No. 4: DTC 28 (B301) No. 3 — No. 2:</p>	<p>Is the resistance within the following? Front: 1 — 1.5 kΩ, Rear: 1.025 — 1.265 kΩ</p>	Go to step 17.	<p>Repair the harness connector between ABSCM&H/U and ABS wheel speed sensor.</p>
<p>17 CHECK GROUND SHORT OF HARNESS.</p> <p>Measure the resistance between the ABSCM&H/U connector and chassis ground.</p> <p>Connector & terminal DTC 22 (B301) No. 6 — Chassis ground: DTC 24 (B301) No. 1 — Chassis ground: DTC 26 (B301) No. 19 — Chassis ground: DTC 28 (B301) No. 3 — Chassis ground:</p>	<p>Is the resistance 1 MΩ or more?</p>	Go to step 18.	<p>Repair the harness connector between ABSCM&H/U and ABS wheel speed sensor.</p>
<p>18 CHECK THE ABSCM&H/U GROUND CIRCUIT.</p> <p>Measure the resistance between the ABSCM&H/U and chassis ground.</p> <p>Connector & terminal (B301) No. 15 — Chassis ground:</p>	<p>Is resistance less than 0.5 Ω?</p>	Go to step 19.	<p>Repair the ABSCM&H/U ground harness.</p>
<p>19 CHECK POOR CONTACT OF CONNECTOR.</p>	<p>Is there poor contact in connectors between ABSCM&H/U and ABS wheel speed sensor?</p>	Repair the connector.	Go to step 20.

Diagnostic Procedure with Diagnostic Trouble Code (DTC)

ABS (DIAGNOSTICS)

Step	Check	Yes	No
20 CHECK CAUSE OF SIGNAL NOISE.	Is the car telephone or the radio properly installed?	Go to step 21 .	Install the car telephone or radio properly.
21 CHECK CAUSE OF SIGNAL NOISE.	Is there a noise source (such as an antenna) installed near the sensor harness?	Install the noise source apart from the sensor harness.	Go to step 22 .
22 CHECK ABSCM&H/U. 1) Connect all connectors. 2) Erase the memory. 3) Perform the Inspection Mode. 4) Read the DTC.	Is the same DTC still output?	Replace the ABSCM&H/U. <Ref. to ABS-6, ABS Control Module and Hydraulic Control Unit (ABSCM&H/U).>	Go to step 23 .
23 CHECK OTHER DTC DETECTION.	Is there any other DTC detected?	Perform the diagnosis according to DTC.	It results from a temporary noise interference. NOTE: Though the ABS warning light remains on at this time, this is normal. Drive the vehicle at 12 km/h (7.46 MPH) or more in order to turn ABS warning light off. Be sure to drive the vehicle and check that the warning light goes off.

Diagnostic Procedure with Diagnostic Trouble Code (DTC)

ABS (DIAGNOSTICS)

I: DTC 29 ABNORMAL ABS WHEEL SPEED SENSOR SIGNAL ON ANY ONE OF FOUR SENSOR

DIAGNOSIS:

- Defective ABS wheel speed sensor signal (noise, irregular signal, etc.)
- Faulty tone wheel
- When a wheel is turned freely for a long time

TROUBLE SYMPTOM:

- ABS does not operate.
- EBD does not operate.

NOTE:

Brake warning light illuminates as well as the ABS warning light.

Diagnostic Procedure with Diagnostic Trouble Code (DTC)

ABS (DIAGNOSTICS)

WIRING DIAGRAM:

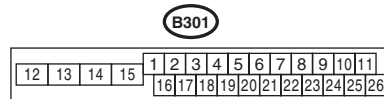
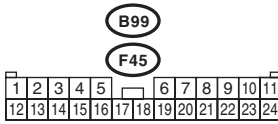
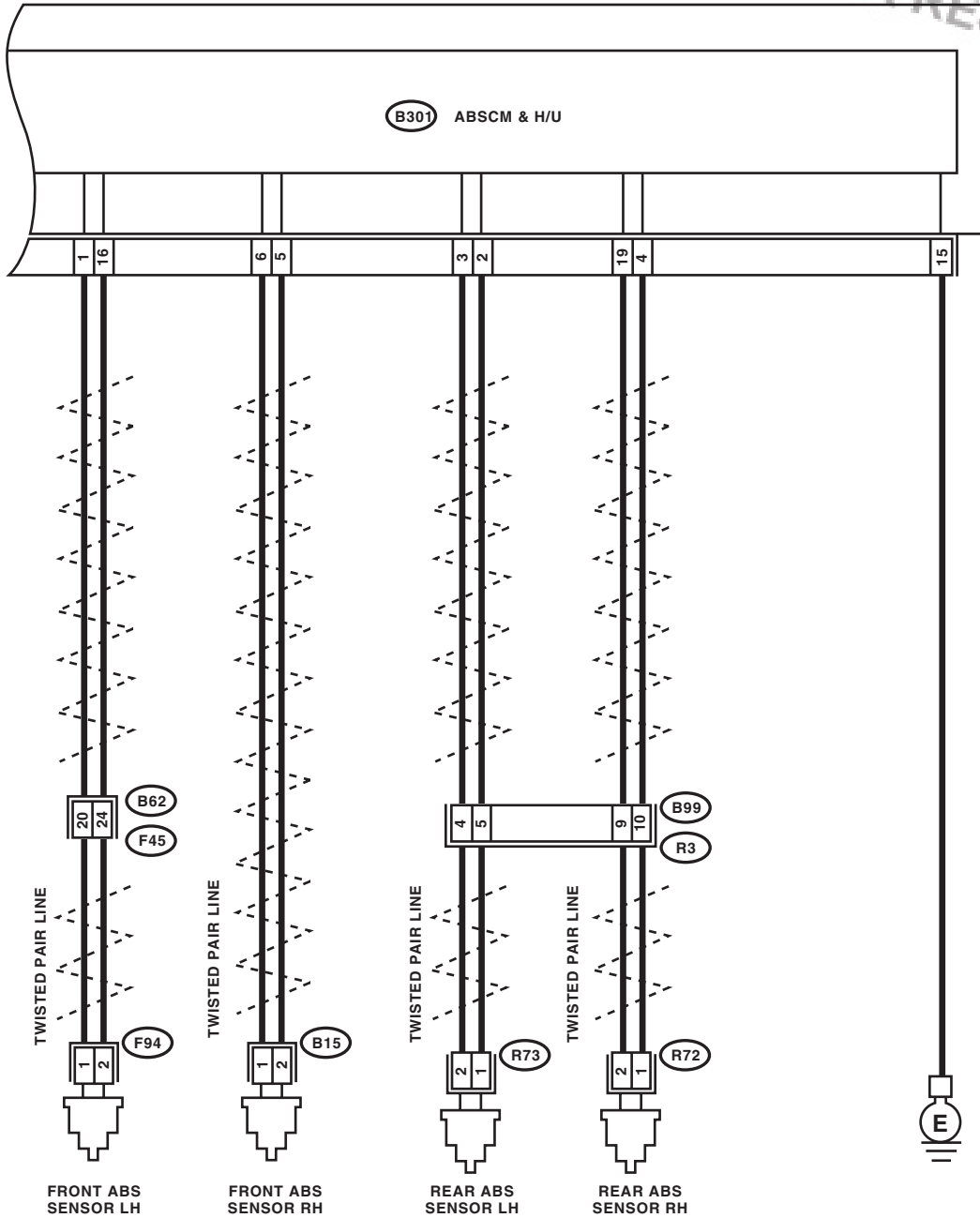

ABS00967

Diagnostic Procedure with Diagnostic Trouble Code (DTC)

ABS (DIAGNOSTICS)

Step	Check	Yes	No	
1	WHETHER A WHEEL TURNED FREELY OR NOT.	Check if the wheels have been turned freely for one minute or more, such as when the vehicle is jacked-up, under full-lock cornering or when the wheels are not in contact with road surface.	ABS is normal. Erase the memory. NOTE: This diagnostic trouble code may sometimes occur if the wheels turn freely for a long time, for example when the vehicle is towed or jacked-up, or when steering wheel is continuously turned all the way.	Go to step 2.
2	CHECK TIRE SPECIFICATIONS. Turn the ignition switch to OFF.	Are the tire specifications correct?	Go to step 3.	Replace the tire.
3	CHECK WEAR OF TIRE.	Is the tire worn excessively?	Replace the tire.	Go to step 4.
4	CHECK TIRE PRESSURE.	Is the tire pressure correct?	Go to step 5.	Adjust the tire pressure.
5	CHECK INSTALLATION OF ABS WHEEL SPEED SENSOR.	Is the ABS wheel speed sensor installation bolt tightened 33 N·m (3.3 kgf-m, 24 ft-lb)?	Go to step 6.	Tighten the ABS wheel speed sensor installation bolts.
6	CHECK ABS WHEEL SPEED SENSOR GAP. Measure the gap between the ABS wheel speed sensor protrusion and tone wheel.	Is the gap within the following? Front wheel: 0.3 — 0.8 mm (0.012 — 0.031 in), Rear wheel: 0.7 — 1.2 mm (0.028 — 0.047 in)	Go to step 7.	Adjust the gap. NOTE: Adjust the gap using spacers (Part No. 26755AA000). If spacers cannot correct the gap, replace the worn sensor or worn tone wheel.
7	PREPARE OSCILLOSCOPE.	Is an oscilloscope available?	Go to step 8.	Go to step 9.
8	CHECK ABS WHEEL SPEED SENSOR SIGNAL. 1) Lift up the vehicle. 2) Turn the ignition switch to OFF. 3) Connect the oscilloscope according to the DTC. 4) Turn the ignition switch to ON. 5) Start the wheel, and measure the voltage at the specified frequency. <Ref. to ABS(diag)-14, WAVEFORM, Control Module I/O Signal.> NOTE: When this inspection is completed, ABSCM&H/U may record DTC 29. Connector & terminal Front RH (B15) No. 1 (+) — No. 2 (-): Front LH (B62) No. 20 (+) — No. 24 (-): Rear RH (B99) No. 10 (+) — No. 9 (-): Rear LH (B99) No. 5 (+) — No. 4 (-):	Is the oscilloscope pattern the same waveform as shown in the figure?	Go to step 12.	Go to step 9.

Diagnostic Procedure with Diagnostic Trouble Code (DTC)

ABS (DIAGNOSTICS)

Step	Check	Yes	No	
9	CHECK CONTAMINATION OF ABS WHEEL SPEED SENSOR OR TONE WHEEL. Remove the disc rotor or drum from the hub.	Is the ABS wheel speed sensor piece or the tone wheel contaminated by dirt or other foreign matter?	Thoroughly remove dirt or other foreign matter.	Go to step 10.
10	CHECK DAMAGE OF ABS WHEEL SPEED SENSOR OR TONE WHEEL.	Are there cracked or damaged teeth in the protrusion of the ABS wheel speed sensor or the tone wheel?	Replace the ABS wheel speed sensor or tone wheel. Front: <Ref. to ABS-13, Front ABS Wheel Speed Sensor.> Rear: <Ref. to ABS-16, Rear ABS Wheel Speed Sensor.> and front: <Ref. to ABS-18, Front Tone Wheel.> Rear: <Ref. to ABS-19, Rear Tone Wheel.>	Go to step 11.
11	CHECK TONE WHEEL RUNOUT. Measure the tone wheel runout.	Is the runout less than 0.05 mm (0.0020 in)?	Go to step 12.	Replace the tone wheel. Front: <Ref. to ABS-18, Front Tone Wheel.> Rear: <Ref. to ABS-19, Rear Tone Wheel.>
12	CHECK ABSCM&H/U. 1) Turn the ignition switch to OFF. 2) Connect all connectors. 3) Erase the memory. 4) Perform the Inspection Mode. 5) Read the DTC.	Is the same DTC still output?	Replace the ABSCM&H/U. <Ref. to ABS-6, ABS Control Module and Hydraulic Control Unit (ABSCM&H/U).>	Go to step 13.
13	CHECK OTHER DTC DETECTION.	Is there any other DTC detected?	Perform the diagnosis according to DTC.	Temporary poor contact occurs.

J: DTC 31 FRONT RIGHT INLET VALVE MALFUNCTION

NOTE:

Refer to DTC 37 for the diagnostic procedure. <Ref. to ABS(diag)-51, DTC 37 REAR LEFT INLET VALVE MALFUNCTION, Diagnostic Procedure with Diagnostic Trouble Code (DTC).>

K: DTC 33 FRONT LEFT INLET VALVE MALFUNCTION

NOTE:

Refer to DTC 37 for the diagnostic procedure. <Ref. to ABS(diag)-51, DTC 37 REAR LEFT INLET VALVE MALFUNCTION, Diagnostic Procedure with Diagnostic Trouble Code (DTC).>

L: DTC 35 REAR RIGHT INLET VALVE MALFUNCTION

NOTE:

Refer to DTC 37 for the diagnostic procedure. <Ref. to ABS(diag)-51, DTC 37 REAR LEFT INLET VALVE MALFUNCTION, Diagnostic Procedure with Diagnostic Trouble Code (DTC).>

Diagnostic Procedure with Diagnostic Trouble Code (DTC)

ABS (DIAGNOSTICS)

M: DTC 37 REAR LEFT INLET VALVE MALFUNCTION

DIAGNOSIS:

- Defective harness connector
- Defective inlet solenoid valve

TROUBLE SYMPTOM:

- ABS does not operate.
- EBD does not operate.

NOTE:

Brake warning light illuminates as well as the ABS warning light.

Diagnostic Procedure with Diagnostic Trouble Code (DTC)

ABS (DIAGNOSTICS)

WIRING DIAGRAM:

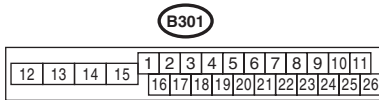
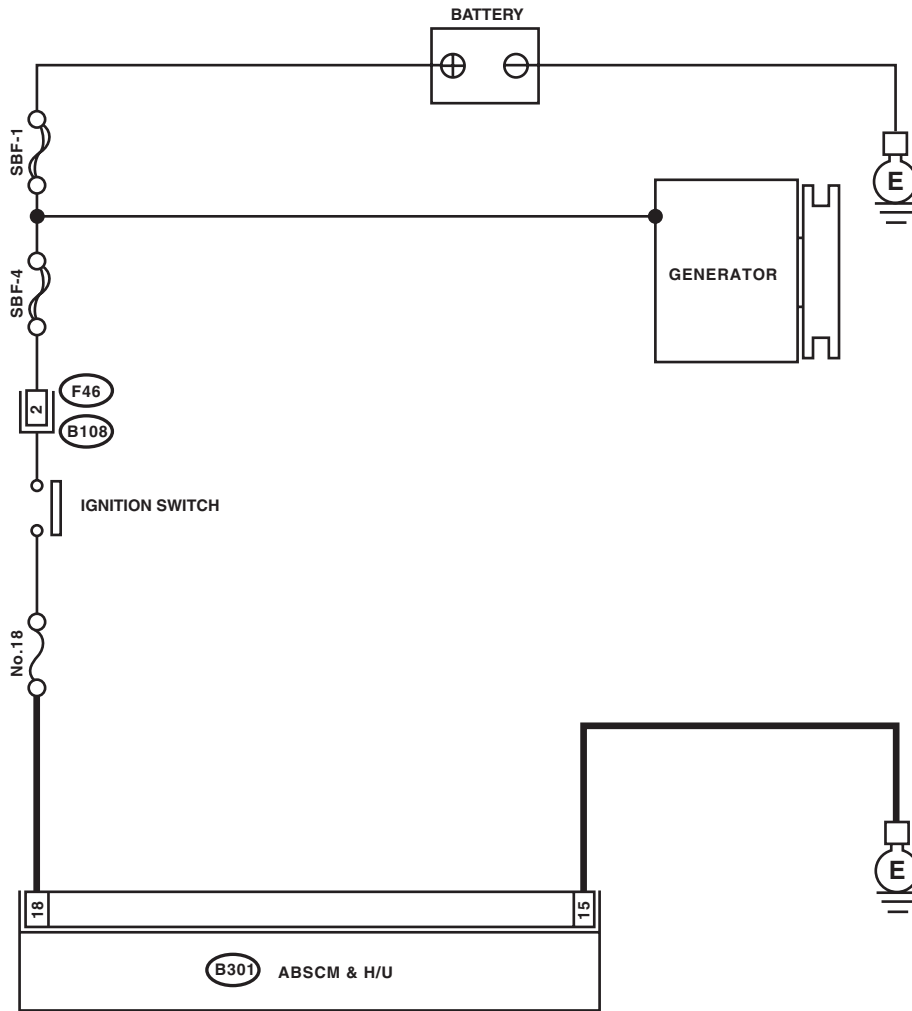

ABS00958

Diagnostic Procedure with Diagnostic Trouble Code (DTC)

ABS (DIAGNOSTICS)

Step	Check	Yes	No
1 CHECK INPUT VOLTAGE OF ABSCM&H/U. 1) Turn the ignition switch to OFF. 2) Disconnect the ABSCM&H/U connectors. 3) Idle the engine. 4) Measure the voltage between ABSCM&H/U connector and chassis ground. Connector & terminal (B301) No. 18 (+) — Chassis ground (-):	Is the voltage 10 — 15 V?	Go to step 2.	Repair the harness connector between battery, ignition switch and ABSCM&H/U.
2 CHECK THE ABSCM&H/U GROUND CIRCUIT. 1) Turn the ignition switch to OFF. 2) Measure the resistance between the ABSCM&H/U connector and chassis ground. Connector & terminal (B301) No. 15 — Chassis ground:	Is resistance less than 0.5 Ω?	Go to step 3.	Repair the ABSCM&H/U ground harness.
3 CHECK POOR CONTACT OF CONNECTOR.	Is there poor contact in connector between generator, battery and ABSCM&H/U?	Repair the connector.	Go to step 4.
4 CHECK ABSCM&H/U. 1) Connect all connectors. 2) Erase the memory. 3) Perform the Inspection Mode. 4) Read the DTC.	Is the same DTC still output?	Replace the ABSCM&H/U. <Ref. to ABS-6, ABS Control Module and Hydraulic Control Unit (ABSCM&H/U).>	Go to step 5.
5 CHECK OTHER DTC DETECTION.	Is there any other DTC detected?	Perform the diagnosis according to DTC.	Temporary poor contact occurs.

N: DTC 32 FRONT RIGHT OUTLET VALVE MALFUNCTION

NOTE:

Refer to DTC 38 for the diagnostic procedure. <Ref. to ABS(diag)-54, DTC 38 REAR LEFT OUTLET VALVE MALFUNCTION, Diagnostic Procedure with Diagnostic Trouble Code (DTC).>

O: DTC 34 FRONT LEFT OUTLET VALVE MALFUNCTION

NOTE:

Refer to DTC 38 for the diagnostic procedure. <Ref. to ABS(diag)-54, DTC 38 REAR LEFT OUTLET VALVE MALFUNCTION, Diagnostic Procedure with Diagnostic Trouble Code (DTC).>

P: DTC 36 REAR RIGHT OUTLET VALVE MALFUNCTION

NOTE:

Refer to DTC 38 for the diagnostic procedure. <Ref. to ABS(diag)-54, DTC 38 REAR LEFT OUTLET VALVE MALFUNCTION, Diagnostic Procedure with Diagnostic Trouble Code (DTC).>

Diagnostic Procedure with Diagnostic Trouble Code (DTC)

ABS (DIAGNOSTICS)

Q: DTC 38 REAR LEFT OUTLET VALVE MALFUNCTION

DIAGNOSIS:

- Defective harness connector
- Defective outlet solenoid valve

TROUBLE SYMPTOM:

- ABS does not operate.
- EBD does not operate.

NOTE:

Brake warning light illuminates as well as the ABS warning light.

Diagnostic Procedure with Diagnostic Trouble Code (DTC)

ABS (DIAGNOSTICS)

WIRING DIAGRAM:

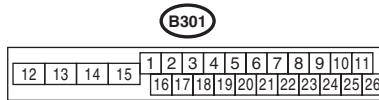
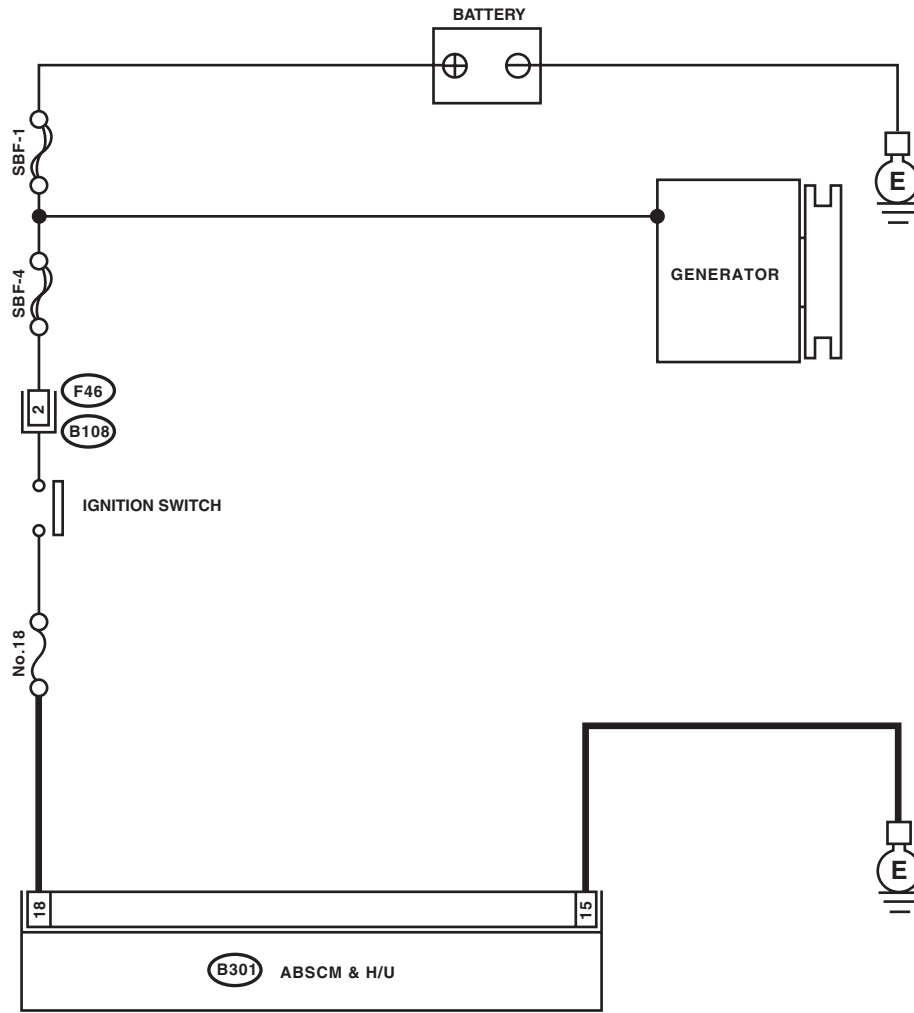

ABS00958

Diagnostic Procedure with Diagnostic Trouble Code (DTC)

ABS (DIAGNOSTICS)

Step	Check	Yes	No
1 CHECK INPUT VOLTAGE OF ABSCM&H/U. 1) Turn the ignition switch to OFF. 2) Disconnect the ABSCM&H/U connectors. 3) Idle the engine. 4) Measure the voltage between ABSCM&H/U connector and chassis ground. <i>Connector & terminal</i> <i>(B301) No. 18 (+) — Chassis ground (-):</i>	Is the voltage 10 — 15 V?	Go to step 2.	Repair the harness connector between battery, ignition switch and ABSCM&H/U.
2 CHECK THE ABSCM&H/U GROUND CIRCUIT. 1) Turn the ignition switch to OFF. 2) Measure the resistance between the ABSCM&H/U connector and chassis ground. <i>Connector & terminal</i> <i>(B301) No. 15 — Chassis ground:</i>	Is resistance less than 0.5 Ω?	Go to step 3.	Repair the ABSCM&H/U ground harness.
3 CHECK POOR CONTACT OF CONNECTOR.	Is there poor contact in connector between generator, battery and ABSCM&H/U?	Repair the connector.	Go to step 4.
4 CHECK ABSCM&H/U. 1) Connect all connectors. 2) Erase the memory. 3) Perform the Inspection Mode. 4) Read the DTC.	Is the same DTC still output?	Replace the ABSCM&H/U. <Ref. to ABS-6, ABS Control Module and Hydraulic Control Unit (ABSCM&H/U).>	Go to step 5.
5 CHECK OTHER DTC DETECTION.	Is there any other DTC detected?	Perform the diagnosis according to DTC.	Temporary poor contact occurs.

Diagnostic Procedure with Diagnostic Trouble Code (DTC)

ABS (DIAGNOSTICS)

R: DTC 41 ABS CONTROL MODULE MALFUNCTION

DIAGNOSIS:

Defective ABSCM&H/U

TROUBLE SYMPTOM:

- ABS does not operate.
- EBD does not operate.

NOTE:

Brake warning light illuminates as well as the ABS warning light.

WIRING DIAGRAM:

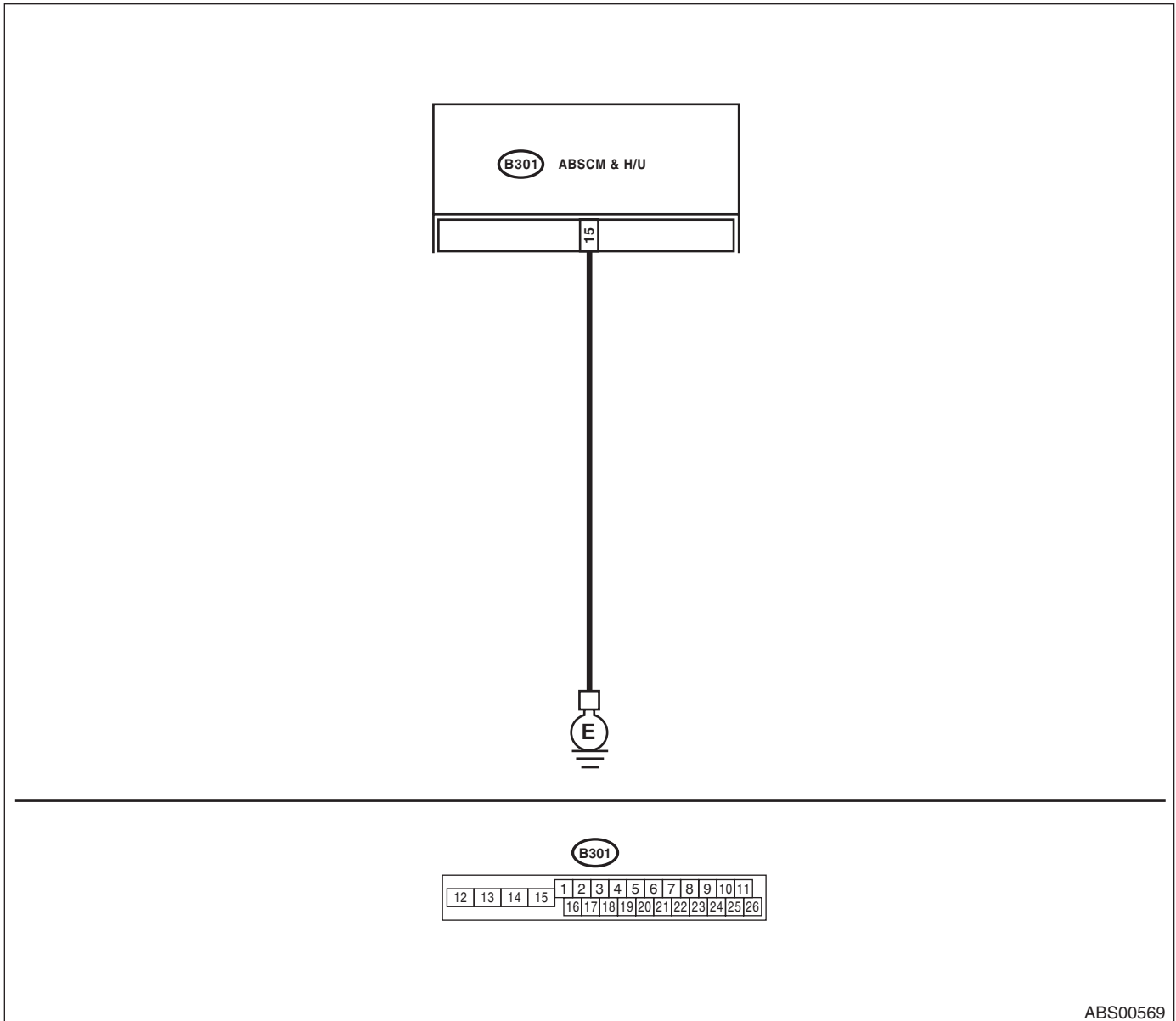

ABS00569

Diagnostic Procedure with Diagnostic Trouble Code (DTC)

ABS (DIAGNOSTICS)

Step	Check	Yes	No
1 CHECK THE ABSCM&H/U GROUND CIRCUIT. 1) Turn the ignition switch to OFF. 2) Disconnect the ABSCM&H/U connectors. 3) Measure the resistance between the ABSCM&H/U and chassis ground. Connector & terminal (B301) No. 15 — Chassis ground:	Is resistance less than 0.5 Ω?	Go to step 2.	Repair the ABSCM&H/U ground harness.
2 CHECK POOR CONTACT OF CONNECTOR.	Is there poor contact of the connector between the battery, ignition switch and ABSCM&H/U?	Repair the connector.	Go to step 3.
3 CHECK CAUSE OF SIGNAL NOISE.	Is the car telephone or the radio properly installed?	Go to step 4.	Install the car telephone or radio properly.
4 CHECK CAUSE OF SIGNAL NOISE.	Is there a noise source (such as an antenna) installed near the sensor harness?	Install the noise source apart from the sensor harness.	Go to step 5.
5 CHECK ABSCM&H/U. 1) Turn the ignition switch to OFF. 2) Connect all connectors. 3) Erase the memory. 4) Perform the Inspection Mode. 5) Read the DTC.	Is the same DTC still output?	Replace the ABSCM&H/U. <Ref. to ABS-6, ABS Control Module and Hydraulic Control Unit (ABSCM&H/U).>	Go to step 6.
6 CHECK OTHER DTC DETECTION.	Is there any other DTC detected?	Perform the diagnosis according to DTC.	Temporary poor contact occurs.

Diagnostic Procedure with Diagnostic Trouble Code (DTC)

ABS (DIAGNOSTICS)

S: DTC 42 POWER VOLTAGE MALFUNCTION

DIAGNOSIS:

Power supply voltage of the ABSCM&H/U is too low or too high.

TROUBLE SYMPTOM:

- ABS does not operate.
- EBD may not operate.

NOTE:

If EBD does not operate, the brake warning light illuminates temporarily in addition to ABS warning light. Warning lights go off if voltage returns.

Diagnostic Procedure with Diagnostic Trouble Code (DTC)

ABS (DIAGNOSTICS)

WIRING DIAGRAM:

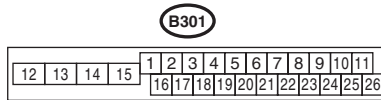
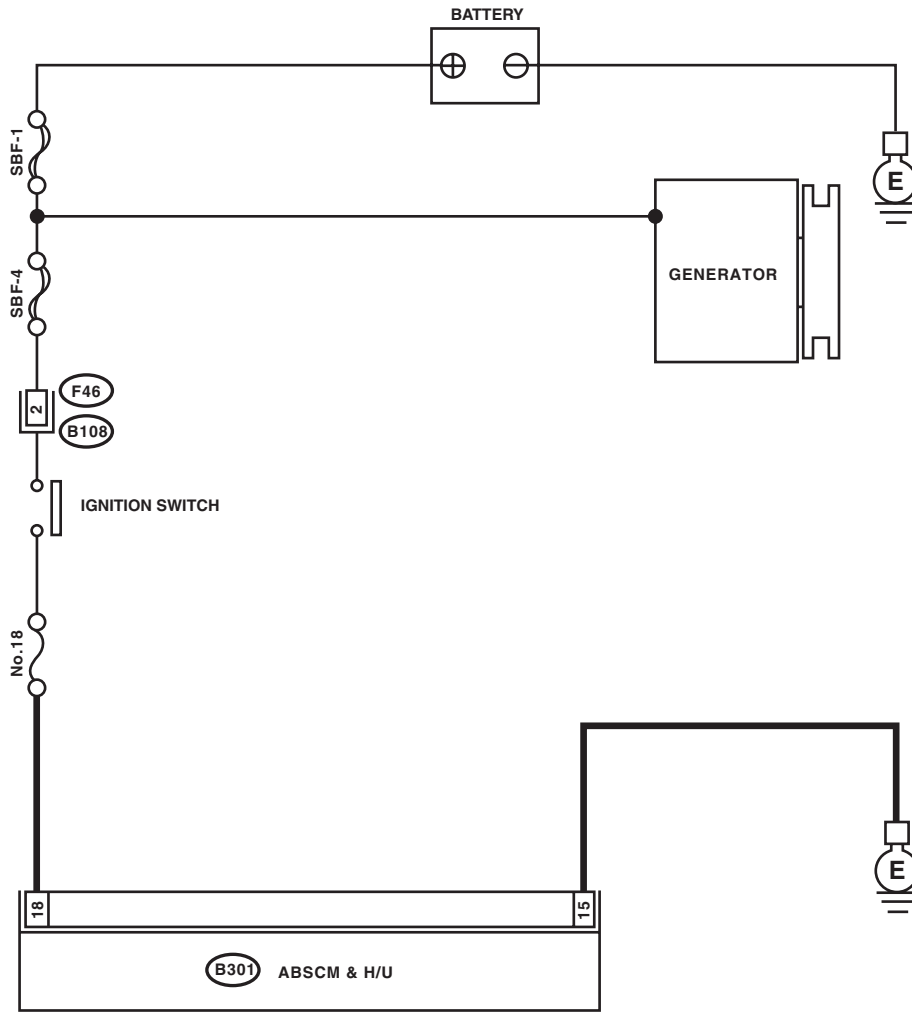

ABS00958

Diagnostic Procedure with Diagnostic Trouble Code (DTC)

ABS (DIAGNOSTICS)

	Step	Check	Yes	No
1	CHECK GENERATOR. 1) Start the engine. 2) Run the engine at idle after warming up. 3) Measure the voltage between generator terminal B and chassis ground. Terminals Generator B terminal (+) — Chassis ground (-):	Is the voltage 10 — 15 V?	Go to step 2.	Repair the generator. <Ref. to SC(H4SO)-14, Generator.>
2	CHECK BATTERY TERMINAL. Turn the ignition switch to OFF.	Are the positive and negative battery terminals clamped tightly?	Go to step 3.	Tighten the terminal.
3	CHECK INPUT VOLTAGE OF ABSCM&H/U. 1) Disconnect the ABSCM&H/U connectors. 2) Idle the engine. 3) Operate devices such as headlights, air conditioner, defogger, etc. which produce an electrical load. 4) Measure the voltage between ABSCM&H/U connector and chassis ground. Connector & terminal (B301) No. 18 (+) — Chassis ground (-):	Is the voltage 10 — 15 V?	Go to step 4.	Repair the harness connector between battery, ignition switch and ABSCM&H/U.
4	CHECK THE ABSCM&H/U GROUND CIRCUIT. 1) Turn the ignition switch to OFF. 2) Measure the resistance between the ABSCM&H/U connector and chassis ground. Connector & terminal (B301) No. 15 — Chassis ground:	Is resistance less than 0.5 Ω?	Go to step 5.	Repair the ABSCM&H/U ground harness.
5	CHECK POOR CONTACT OF CONNECTOR.	Is there poor contact in connector between generator, battery and ABSCM&H/U?	Repair the connector.	Go to step 6.
6	CHECK ABSCM&H/U. 1) Connect all connectors. 2) Erase the memory. 3) Perform the Inspection Mode. 4) Read the DTC.	Is the same DTC still output?	Replace the ABSCM&H/U. <Ref. to ABS-6, ABS Control Module and Hydraulic Control Unit (ABSCM&H/U).>	Go to step 7.
7	CHECK OTHER DTC DETECTION.	Is there any other DTC detected?	Perform the diagnosis according to DTC.	Temporary poor contact occurs.

Diagnostic Procedure with Diagnostic Trouble Code (DTC)

ABS (DIAGNOSTICS)

T: DTC 47 IMPROPER CAN COMMUNICATION

DIAGNOSIS:

CAN communication line is damaged or circuit is shorted.

TROUBLE SYMPTOM:

- ABS does not operate. (STI model)
- Tight corner braking phenomenon occurs. (AT model)

WIRING DIAGRAM:

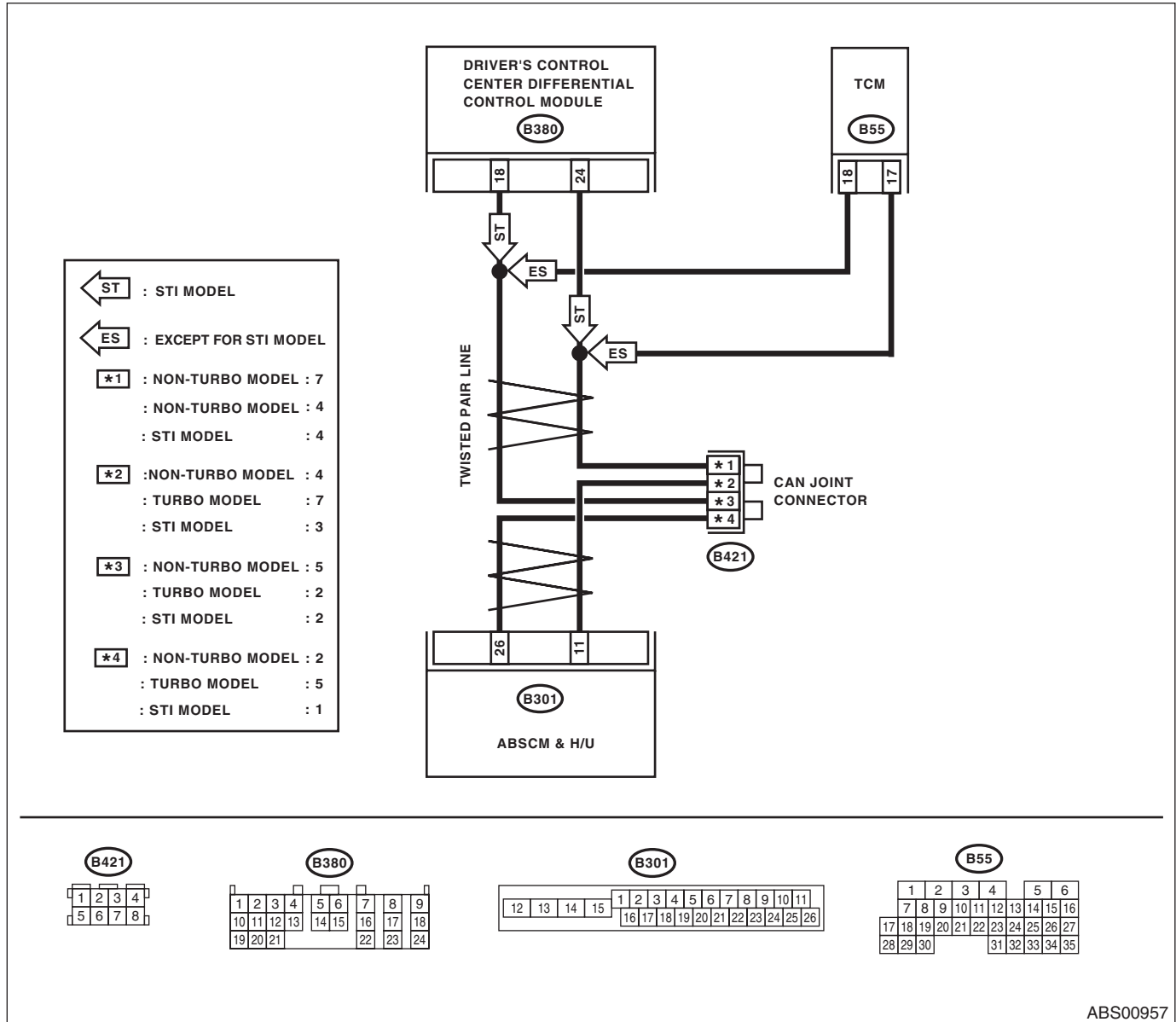

ABS00957

Diagnostic Procedure with Diagnostic Trouble Code (DTC)

ABS (DIAGNOSTICS)

	Step	Check	Yes	No
1	CONFIRM VEHICLE TYPE.	Is the vehicle STI model?	Go to step 2.	Go to step 11.
2	CHECK HARNESS CONNECTOR BETWEEN ABSCM AND DRIVER'S CONTROL CENTER DIFFERENTIAL CONTROL MODULE. 1) Turn the ignition switch to ON. 2) Disconnect the connector from ABSCM and driver's control center differential control module. 3) Measure the resistance of harness connectors between ABSCM and driver's control center differential control module. Connector & terminal (B301) No. 26 — (B380) No. 18: (B301) No. 11 — (B380) No. 24:	Is resistance less than 0.5 Ω?	Go to step 3.	Repair or replace harness connector between ABSCM and driver's control center differential control module.
3	CHECK GROUND SHORT OF THE HARNESS CONNECTOR BETWEEN ABSCM AND DRIVER'S CONTROL CENTER DIFFERENTIAL CONTROL MODULE. Measure the resistance between ABSCM connector and chassis ground. Connector & terminal (B301) No. 26 — Chassis ground: (B301) No. 11 — Chassis ground:	Is the resistance 1 MΩ or more?	Go to step 4.	Repair or replace harness connector between ABSCM and driver's control center differential control module.
4	CHECK BATTERY SHORT OF THE HARNESS CONNECTOR BETWEEN ABSCM AND DRIVER'S CONTROL CENTER DIFFERENTIAL CONTROL MODULE. 1) Turn the ignition switch to ON. 2) Measure the voltage between ABSCM connector and chassis ground. Connector & terminal (B301) No. 26 — Chassis ground: (B301) No. 11 — Chassis ground:	Is the voltage less than 0.5 V?	Go to step 5.	Repair or replace harness connector between ABSCM and driver's control center differential control module.
5	CHECK ABSCM. 1) Turn the ignition switch to OFF. 2) Connect the connector to ABSCM. 3) Measure the resistance between the driver's control center differential control module terminals. Connector & terminal (B380) No. 18 — (B380) No. 24:	Is the resistance 120±6 Ω?	Go to step 7.	Go to step 6.
6	CHECK POOR CONTACT OF ABSCM CONNECTORS.	Is there poor contact?	Repair the poor contact of ABSCM connector.	Replace the ABSCM. <Ref. to ABS-6, ABS Control Module and Hydraulic Control Unit (ABSCM&H/U).>
7	CHECK DRIVER'S CONTROL CENTER DIFFERENTIAL CONTROL MODULE. 1) Connect the driver's control center differential control module to connector. 2) Disconnect the connectors from ABSCM. 3) Measure the resistance between ABSCM connector terminals. Connector & terminal (B301) No. 11 — (B301) No. 26:	Is the resistance 120±6 Ω?	Go to step 9.	Go to step 8.

Diagnostic Procedure with Diagnostic Trouble Code (DTC)

ABS (DIAGNOSTICS)

Step	Check	Yes	No
8 CHECK POOR CONTACT OF THE DRIVER'S CONTROL CENTER DIFFERENTIAL CONTROL MODULE CONNECTOR.	Is there poor contact?	Repair poor contact of the driver's control center differential control module connector.	Replace the driver's control center differential control module. <Ref. to 6MT-122, Driver's Control Center Differential Control Module.>
9 CHECK DTC DETECTION.	Is DTC 47 is detected?	Replace the ABSCM. <Ref. to ABS-6, ABS Control Module and Hydraulic Control Unit (ABSCM&H/U).>	Go to step 10 .
10 CHECK IF DRIVER'S CONTROL CENTER DIFFERENTIAL AUTO SYSTEM DTC P1720 IS DETECTED.	Is DTC P1720 detected?	Replace the driver's control center differential control module. <Ref. to 6MT-122, Driver's Control Center Differential Control Module.>	Replace the ABSCM. <Ref. to ABS-6, ABS Control Module and Hydraulic Control Unit (ABSCM&H/U).>
11 CHECK HARNESS CONNECTOR BETWEEN ABSCM AND TCM. 1) Turn the ignition switch to ON. 2) Disconnect the connectors from ABSCM and TCM. 3) Measure the resistance of harness connector between ABSCM and TCM. Connector & terminal (B301) No. 26 — (B55) No. 18: (B301) No. 11 — (B55) No. 17:	Is resistance less than 0.5 Ω?	Go to step 12 .	Repair or replace harness connector between ABSCM and TCM.
12 CHECK GROUND SHORT OF THE HARNESS CONNECTOR BETWEEN ABSCM AND TCM. Measure the resistance between ABSCM connector and chassis ground. Connector & terminal (B301) No. 26 — Chassis ground: (B301) No. 11 — Chassis ground:	Is the resistance 1 MΩ or more?	Go to step 13 .	Repair or replace harness connector between ABSCM and TCM.
13 CHECK BATTERY SHORT OF THE HARNESS CONNECTOR BETWEEN ABSCM AND TCM. 1) Turn the ignition switch to ON. 2) Measure the voltage between ABSCM connector and chassis ground. Connector & terminal (B301) No. 26 — Chassis ground: (B301) No. 11 — Chassis ground:	Is the voltage less than 1.0 V?	Go to step 14 .	Repair or replace harness connector between ABSCM and TCM.
14 CHECK ABSCM. 1) Turn the ignition switch to OFF. 2) Connect the connector to ABSCM. 3) Measure the resistance between TCM connector terminals. Connector & terminal (B55) No. 17 — (B55) No. 18:	Is the resistance 120±6 Ω?	Go to step 16 .	Go to step 15 .

Diagnostic Procedure with Diagnostic Trouble Code (DTC)

ABS (DIAGNOSTICS)

Step	Check	Yes	No
15 CHECK POOR CONTACT OF ABSCM CONNECTORS.	Is there poor contact?	Repair the poor contact of ABSCM connector.	Replace the ABSCM. <Ref. to ABS-6, ABS Control Module and Hydraulic Control Unit (ABSCM&H/U).>
16 CHECK TCM. 1) Connect the connector to the TCM. 2) Disconnect the connectors from ABSCM. 3) Measure the resistance between ABSCM connector terminals. <i>Connector & terminal (B301) No. 11 — (B301) No. 26:</i>	Is the resistance 120±6 Ω?	Go to step 18.	Go to step 17.
17 CHECK POOR CONTACT OF TCM CONNECTORS.	Is there poor contact?	Repair the poor contact of TCM connector.	Replace the TCM. <Ref. to 4AT-60, Transmission Control Module (TCM).>
18 CHECK DTC DETECTION.	Is DTC 47 is detected?	Replace the ABSCM. <Ref. to ABS-6, ABS Control Module and Hydraulic Control Unit (ABSCM&H/U).>	Go to step 19.
19 CHECK IF TCM SYSTEM DTC P1718 IS DETECTED.	Is DTC P1718 detected?	Replace the TCM. <Ref. to 4AT-60, Transmission Control Module (TCM).>	Replace the ABSCM. <Ref. to ABS-6, ABS Control Module and Hydraulic Control Unit (ABSCM&H/U).>

Diagnostic Procedure with Diagnostic Trouble Code (DTC)

ABS (DIAGNOSTICS)

U: DTC 51 VALVE RELAY MALFUNCTION

DIAGNOSIS:

Defective valve relay

TROUBLE SYMPTOM:

- ABS does not operate.
- EBD does not operate depending on the trouble contents.

NOTE:

Brake warning light illuminates as well as the ABS warning light.

WIRING DIAGRAM:

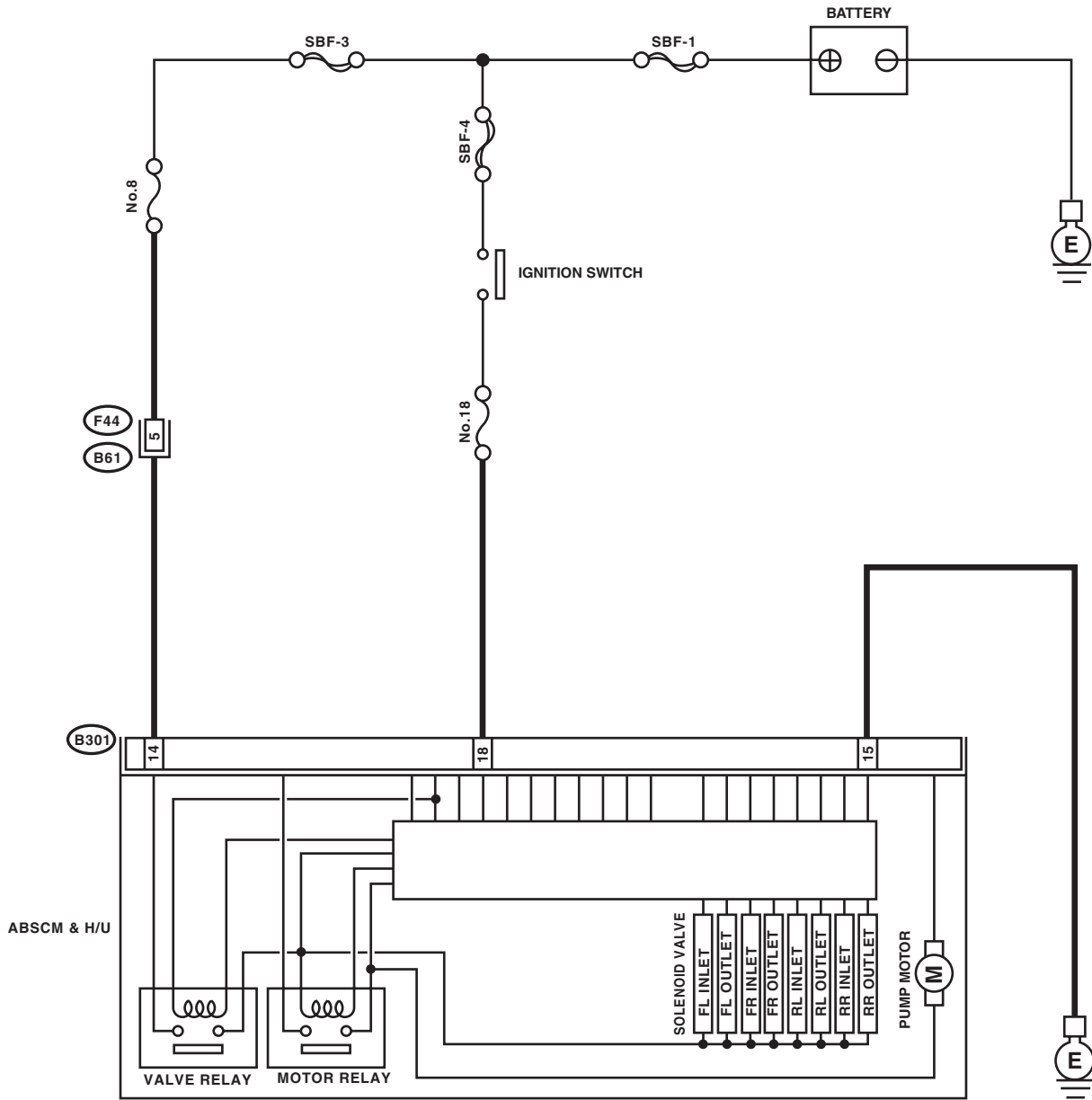

Diagnostic Procedure with Diagnostic Trouble Code (DTC)

ABS (DIAGNOSTICS)

Step	Check	Yes	No
1 CHECK INPUT VOLTAGE OF ABSCM&H/U. 1) Turn the ignition switch to OFF. 2) Disconnect the ABSCM&H/U connectors. 3) Idle the engine. 4) Measure the voltage between ABSCM&H/U connector and chassis ground. <i>Connector & terminal</i> <i>(B301) No. 18 (+) — Chassis ground (-):</i> <i>(B301) No. 14 (+) — Chassis ground (-):</i>	Is the voltage 10 — 15 V?	Go to step 2.	Repair the harness connector between battery and ABSCM&H/U.
2 CHECK THE ABSCM&H/U GROUND CIRCUIT. 1) Turn the ignition switch to OFF. 2) Measure the resistance between the ABSCM&H/U connector and chassis ground. <i>Connector & terminal</i> <i>(B301) No. 15 — Chassis ground:</i>	Is resistance less than 0.5 Ω?	Go to step 3.	Repair the ABSCM&H/U ground harness.
3 CHECK VALVE RELAY IN ABSCM&H/U. Measure the resistance between the ABSCM&H/U terminals. <i>Terminals</i> <i>No. 14 — No. 15:</i>	Is the resistance 1 MΩ or more?	Go to step 4.	Replace the ABSCM only. <Ref. to ABS-7, REPLACEMENT, ABS Control Module and Hydraulic Control Unit (ABSCM&H/U).>
4 CHECK POOR CONTACT OF CONNECTOR.	Is there poor contact in connector between generator, battery and ABSCM&H/U?	Repair the connector.	Go to step 5.
5 CHECK ABSCM&H/U. 1) Connect all connectors. 2) Erase the memory. 3) Perform the Inspection Mode. 4) Read the DTC.	Is the same DTC still output?	Replace the ABSCM only. <Ref. to ABS-7, REPLACEMENT, ABS Control Module and Hydraulic Control Unit (ABSCM&H/U).>	Go to step 6.
6 CHECK OTHER DTC DETECTION.	Is there any other DTC detected?	Check DTC using "List of Diagnostic Trouble Code (DTC)". <Ref. to ABS(diag)-34, List of Diagnostic Trouble Code (DTC).>	Temporary poor contact occurs.

Diagnostic Procedure with Diagnostic Trouble Code (DTC)

ABS (DIAGNOSTICS)

V: DTC 52 MOTOR/MOTOR RELAY MALFUNCTION

DIAGNOSIS:

- Defective motor
- Defective motor relay
- Defective harness connector
- Insufficient tightening of ground bolt

TROUBLE SYMPTOM:

- ABS does not operate.
- EBD does not operate.

Diagnostic Procedure with Diagnostic Trouble Code (DTC)

ABS (DIAGNOSTICS)

WIRING DIAGRAM:

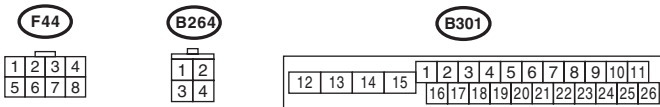
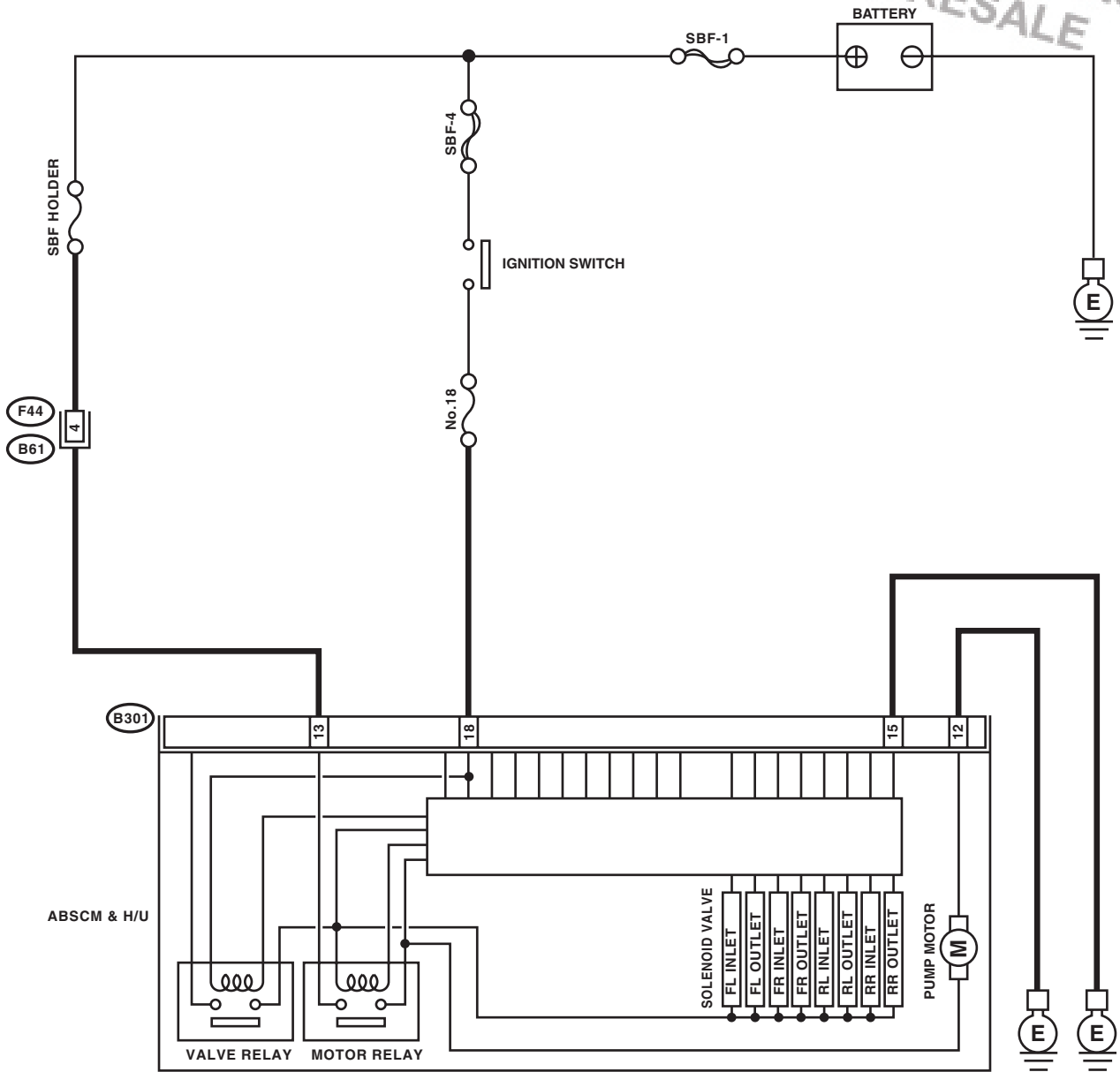

ABS00955

Diagnostic Procedure with Diagnostic Trouble Code (DTC)

ABS (DIAGNOSTICS)

Step	Check	Yes	No
1 CHECK INPUT VOLTAGE OF ABSCM&H/U. 1) Turn the ignition switch to OFF. 2) Disconnect the ABSCM&H/U connectors. 3) Turn the ignition switch to ON. 4) Measure the voltage between ABSCM&H/U connector and chassis ground. <i>Connector & terminal</i> <i>(B301) No. 13 (+) — Chassis ground (-):</i>	Is the voltage 10 — 15 V?	Go to step 2.	Repair the harness connector between battery and ABSCM&H/U and check fuse SBF8.
2 CHECK GROUND CIRCUIT OF MOTOR. 1) Turn the ignition switch to OFF. 2) Measure the resistance between the ABSCM&H/U connector and chassis ground. <i>Connector & terminal</i> <i>(B301) No. 12 — Chassis ground:</i>	Is resistance less than 0.5 Ω?	Go to step 3.	Repair the ABSCM&H/U ground harness.
3 CHECK INPUT VOLTAGE OF ABSCM&H/U. 1) Idle the engine. 2) Measure the voltage between ABSCM&H/U connector and chassis ground. <i>Connector & terminal</i> <i>(B301) No. 18 (+) — Chassis ground (-):</i>	Is the voltage 10 — 15 V?	Go to step 4.	Repair the harness connector between battery, ignition switch and ABSCM&H/U.
4 CHECK THE ABSCM&H/U GROUND CIRCUIT. 1) Turn the ignition switch to OFF. 2) Measure the resistance between the ABSCM&H/U connector and chassis ground. <i>Connector & terminal</i> <i>(B301) No. 15 — Chassis ground:</i>	Is resistance less than 0.5 Ω?	Go to step 5.	Repair the ABSCM&H/U ground harness.
5 CHECK MOTOR OPERATION. Perform sequence control. <Ref. to ABS-10, ABS Sequence Control.> NOTE: Perform sequence control using diagnosis connector.	Can the motor revolution noise (buzz sound) be heard when performing the sequence control?	Go to step 6.	Replace the ABSCM&H/U. <Ref. to ABS-6, ABS Control Module and Hydraulic Control Unit (ABSCM&H/U).>
6 CHECK POOR CONTACT OF CONNECTOR. Turn the ignition switch to OFF.	Is there poor contact in connector between generator, battery and ABSCM&H/U?	Repair the connector.	Go to step 7.
7 CHECK ABSCM&H/U. 1) Connect all connectors. 2) Erase the memory. 3) Perform the Inspection Mode. 4) Read the DTC.	Is the same DTC still output?	Replace the ABSCM&H/U. <Ref. to ABS-6, ABS Control Module and Hydraulic Control Unit (ABSCM&H/U).>	Go to step 8.
8 CHECK OTHER DTC DETECTION.	Is there any other DTC detected?	Perform the diagnosis according to DTC.	Temporary poor contact occurs.

Diagnostic Procedure with Diagnostic Trouble Code (DTC)

ABS (DIAGNOSTICS)

W: DTC 54 STOP LIGHT SWITCH SIGNAL CIRCUIT MALFUNCTION

DIAGNOSIS:

Defective stop light switch

WIRING DIAGRAM:

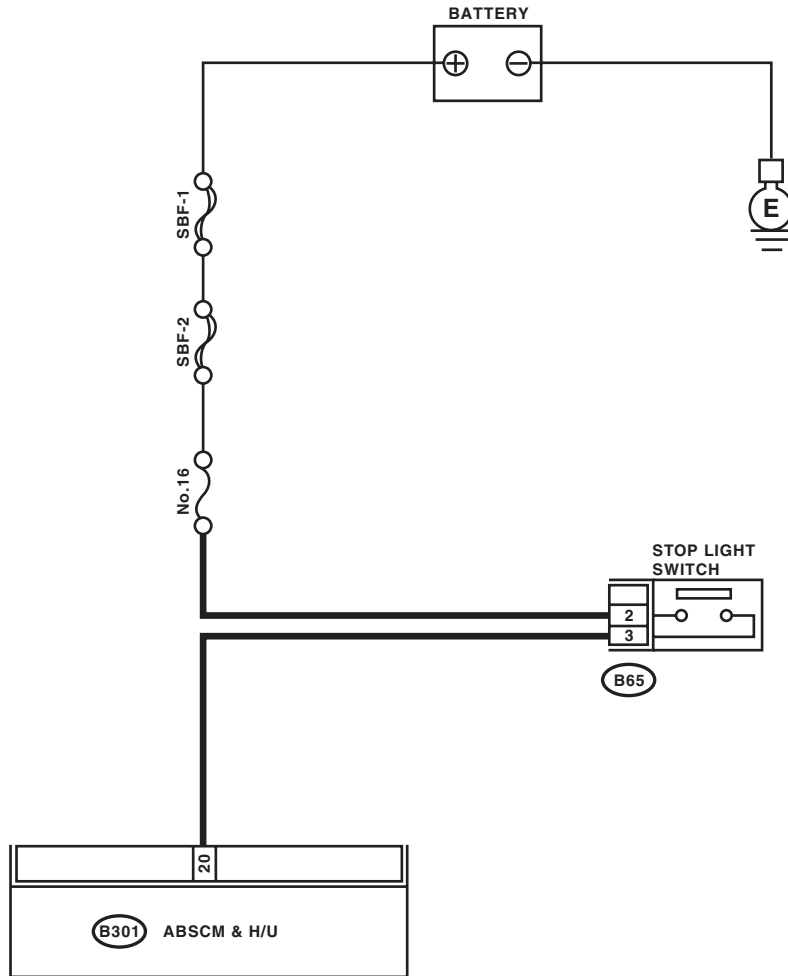

ABS00573

Diagnostic Procedure with Diagnostic Trouble Code (DTC)

ABS (DIAGNOSTICS)

Step	Check	Yes	No
1 CHECK OUTPUT OF STOP LIGHT SWITCH USING SUBARU SELECT MONITOR. 1) Select {Current Data Display & Save} in the Subaru Select Monitor. 2) Release the brake pedal. 3) Read the stop light switch signal in Subaru Select Monitor.	Is "OFF" displayed on the screen?	Go to step 2.	Go to step 3.
2 CHECK OUTPUT OF STOP LIGHT SWITCH USING SUBARU SELECT MONITOR. 1) Depress the brake pedal. 2) Read the stop light switch signal in Subaru Select Monitor.	Is "ON" displayed on the screen?	Go to step 5.	Go to step 3.
3 CHECK IF STOP LIGHTS COME ON. Depress the brake pedal.	Does the stop light illuminate?	Go to step 4.	Repair the stop light circuit.
4 CHECK OPEN CIRCUIT IN HARNESS. 1) Turn the ignition switch to OFF. 2) Disconnect the ABSCM&H/U connectors. 3) Depress the brake pedal. 4) Measure the voltage between ABSCM&H/U connector and chassis ground. Connector & terminal (B301) No. 20 (+) — Chassis ground (-):	Is the voltage 10 — 15 V?	Go to step 5.	Repair the harness between stop light switch and ABSCM&H/U connector.
5 CHECK POOR CONTACT OF CONNECTOR.	Is there poor contact in the connector between stop light switch and ABSCM&H/U?	Go to step 6.	Repair the connector.
6 CHECK ABSCM&H/U. 1) Connect all connectors. 2) Erase the memory. 3) Perform the Inspection Mode. 4) Read the DTC.	Is the same DTC still output?	Replace the ABSCM&H/U. <Ref. to ABS-6, ABS Control Module and Hydraulic Control Unit (ABSCM&H/U).>	Go to step 7.
7 CHECK OTHER DTC DETECTION.	Is there any other DTC detected?	Perform the diagnosis according to DTC.	Temporary poor contact occurs.

Diagnostic Procedure with Diagnostic Trouble Code (DTC)

ABS (DIAGNOSTICS)

X: DTC 56 G SENSOR OUTPUT VOLTAGE OR OUTPUT SIGNAL MALFUNCTION

DIAGNOSIS:

Defective G sensor

TROUBLE SYMPTOM:

ABS does not operate.

WIRING DIAGRAM:

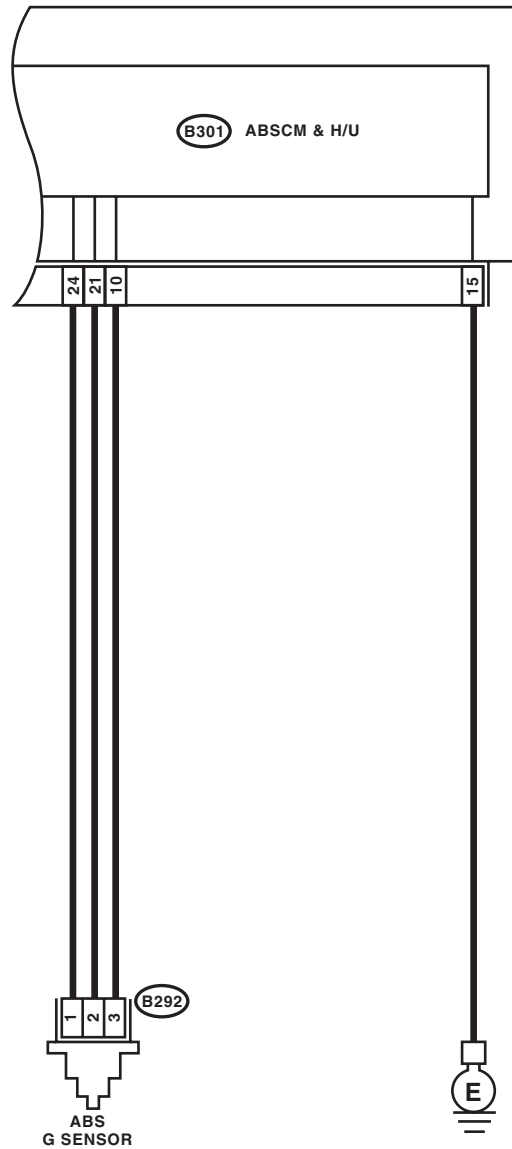

B292

1	2	3
---	---	---

B301

12	13	14	15	1	2	3	4	5	6	7	8	9	10	11
				16	17	18	19	20	21	22	23	24	25	26

ABS00574

Diagnostic Procedure with Diagnostic Trouble Code (DTC)

ABS (DIAGNOSTICS)

Step	Check	Yes	No
1 WHETHER A WHEEL TURNED FREELY OR NOT.	Have the wheels spun free of load when the vehicle is lifted up, or during driving on a rough road?	ABS is normal. Erase the memory.	Go to step 2.
2 CHECK OUTPUT OF G SENSOR USING SUBARU SELECT MONITOR. 1) Select {Current Data Display & Save} in the Subaru Select Monitor. 2) Read the G sensor output on Subaru Select Monitor.	Is the reading indicated on display -1.2 — 1.2 m/s when the G sensor is horizontal?	Go to step 3.	Go to step 6.
3 CHECK POOR CONTACT OF CONNECTOR.	Is there poor contact in connectors between ABSCM&H/U and G sensor?	Repair the connector.	Go to step 4.
4 CHECK ABSCM&H/U. 1) Connect all connectors. 2) Erase the memory. 3) Perform the Inspection Mode. 4) Read the DTC.	Is the same DTC still output?	Replace the ABSCM only. <Ref. to ABS-7, REPLACEMENT, ABS Control Module and Hydraulic Control Unit (ABSCM&H/U).>	Go to step 5.
5 CHECK OTHER DTC DETECTION.	Is there any other DTC detected?	Check DTC using "List of Diagnostic Trouble Code (DTC)". <Ref. to ABS(diag)-34, List of Diagnostic Trouble Code (DTC).>	Temporary poor contact occurs.
6 CHECK INPUT VOLTAGE OF G SENSOR. 1) Turn the ignition switch to OFF. 2) Remove the console box. 3) Remove the G sensor from vehicle. (Do not disconnect the connector.) 4) Turn the ignition switch to ON. 5) Measure the voltage between G sensor connector terminals. Connector & terminal (B292) No. 1 (+) — No. 3 (-):	Is the voltage 4.75 — 5.25 V?	Go to step 7.	Repair the harness connector between the G sensor and ABSCM&H/U.
7 CHECK OPEN CIRCUIT IN G SENSOR OUTPUT HARNESS AND GROUND HARNESS. 1) Turn the ignition switch to OFF. 2) Disconnect the ABSCM&H/U connectors. 3) Measure the resistance between ABSCM&H/U connector terminals. Connector & terminal (B301) No. 21 — No. 10:	Is the resistance 3.6 — 3.8 kΩ?	Go to step 8.	Repair the harness connector between the G sensor and ABSCM&H/U.
8 CHECK GROUND SHORT IN G SENSOR OUTPUT HARNESS. 1) Disconnect the connector from G sensor. 2) Measure the resistance between the ABSCM&H/U connector and chassis ground. Connector & terminal (B301) No. 21 — Chassis ground:	Is the resistance 1 MΩ or more?	Go to step 9.	Repair the harness connector between the G sensor and ABSCM&H/U.

Diagnostic Procedure with Diagnostic Trouble Code (DTC)

ABS (DIAGNOSTICS)

Step	Check	Yes	No
9 CHECK G SENSOR. 1) Connect the connector to G sensor. 2) Connect the connector to ABSCM&H/U. 3) Turn the ignition switch to ON. 4) Measure the voltage between G sensor connector terminals. <i>Connector & terminal (B292) No. 2 (+) — No. 3 (-):</i>	Is the voltage 2.1 — 2.5 V when G sensor is in horizontal position?	Go to step 10.	Replace G sensor. <Ref. to ABS-20, G Sensor.>
10 CHECK G SENSOR. Measure the voltage between G sensor connector terminals. <i>Connector & terminal (B292) No. 2 (+) — No. 3 (-):</i>	Is the voltage 3.6 — 4.1 V when the G sensor is inclined forward to 90°?	Go to step 11.	Replace G sensor. <Ref. to ABS-20, G Sensor.>
11 CHECK G SENSOR. Measure the voltage between G sensor connector terminals. <i>Connector & terminal (B292) No. 2 (+) — No. 3 (-):</i>	Is the voltage 0.5 — 1.0 V when G sensor is inclined back 90°?	Go to step 12.	Replace G sensor. <Ref. to ABS-20, G Sensor.>
12 CHECK POOR CONTACT OF CONNECTOR. Turn the ignition switch to OFF.	Is there poor contact in connectors between ABSCM&H/U and G sensor?	Repair the connector.	Go to step 13.
13 CHECK ABSCM&H/U. 1) Connect all connectors. 2) Erase the memory. 3) Perform the Inspection Mode. 4) Read the DTC.	Is the same DTC still output?	Replace the ABSCM only. <Ref. to ABS-7, REPLACEMENT, ABS Control Module and Hydraulic Control Unit (ABSCM&H/U).>	Go to step 14.
14 CHECK OTHER DTC DETECTION.	Is there any other DTC detected?	Check DTC using “List of Diagnostic Trouble Code (DTC)”. <Ref. to ABS(diag)-34, List of Diagnostic Trouble Code (DTC).>	Temporary poor contact occurs.

Diagnostic Procedure with Diagnostic Trouble Code (DTC)

ABS (DIAGNOSTICS)

Y: DTC 73 LATERAL G SENSOR OUTPUT VOLTAGE OR OUTPUT SIGNAL MALFUNCTION

DIAGNOSIS:

Lateral G sensor malfunction

TROUBLE SYMPTOM:

ABS does not operate.

WIRING DIAGRAM:

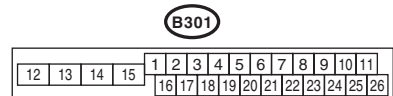
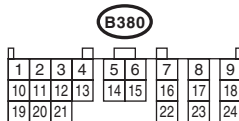
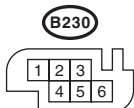
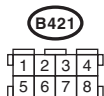
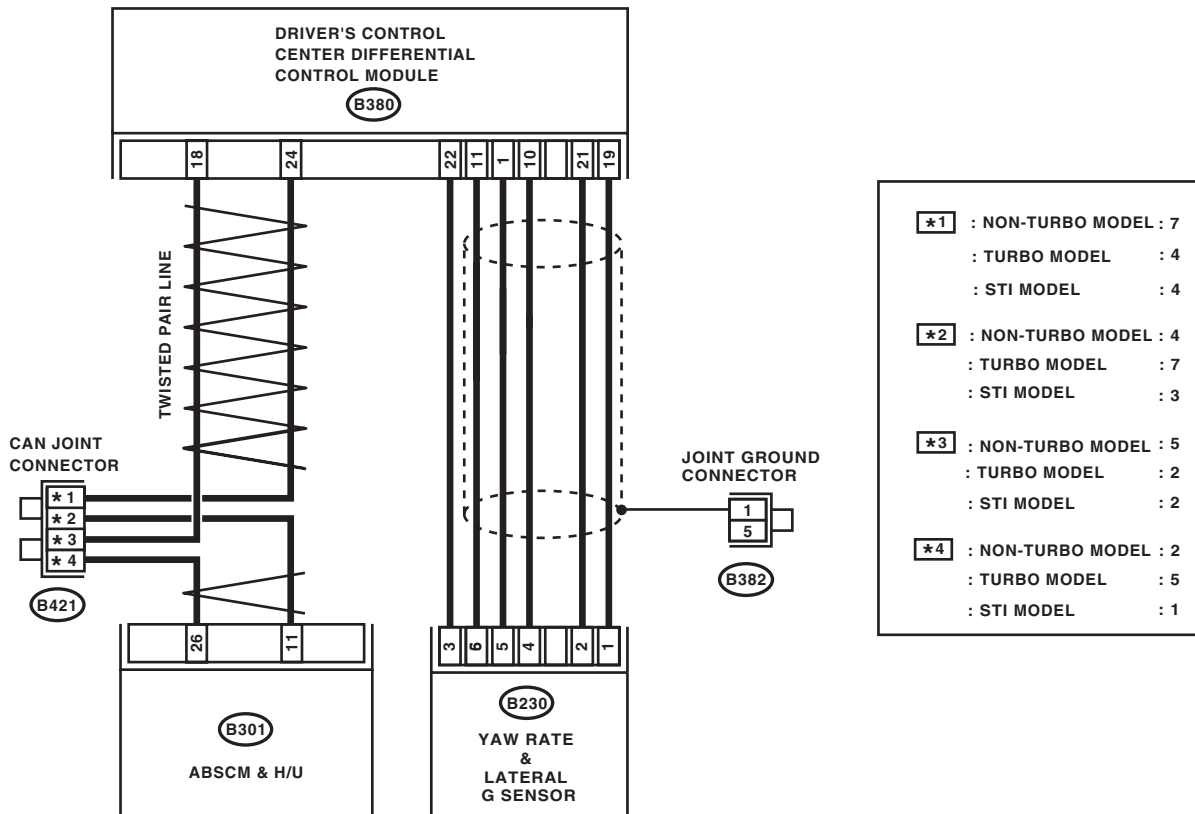

ABS00954

Diagnostic Procedure with Diagnostic Trouble Code (DTC)

ABS (DIAGNOSTICS)

Step	Check	Yes	No
1	WHETHER A WHEEL TURNED FREELY OR NOT.	ABS is normal. Erase the memory.	Go to step 2.
2	CHECK OUTPUT OF YAW RATE & LATERAL G SENSOR USING SUBARU SELECT MONITOR. 1) Select {Current Data Display & Save} in the Subaru Select Monitor. 2) Read the Subaru Select Monitor display.	Go to step 3.	Go to step 8.
3	CHECK OUTPUT OF YAW RATE & LATERAL G SENSOR USING SUBARU SELECT MONITOR. 1) Turn the ignition switch to OFF. 2) Remove the console box. 3) Remove the yaw rate & lateral G sensor from vehicle. (Do not disconnect the connector.) 4) Turn the ignition switch to ON. 5) Select {Current Data Display & Save} in the Subaru Select Monitor. 6) Read the Subaru Select Monitor display.	Go to step 4.	Replace the yaw rate & lateral G sensor. <Ref. to 6MT-121, Yaw Rate and Lateral G Sensor.>
4	CHECK OUTPUT OF YAW RATE & LATERAL G SENSOR USING SUBARU SELECT MONITOR. Read the Subaru Select Monitor display.	Go to step 5.	Replace the yaw rate & lateral G sensor. <Ref. to 6MT-121, Yaw Rate and Lateral G Sensor.>
5	CHECK POOR CONTACT OF CONNECTOR. Turn the ignition switch to OFF.	Repair the connector.	Go to step 6.
6	CHECK ABSCM&H/U. 1) Connect all connectors. 2) Erase the memory. 3) Perform the Inspection Mode. 4) Read the DTC.	Replace the ABSCM. <Ref. to ABS-6, ABS Control Module and Hydraulic Control Unit (ABSCM&H/U).>	Go to step 7.
7	CHECK OTHER DTC DETECTION.	Perform the diagnosis according to DTC.	Temporary poor contact occurs.
8	CHECK OPEN CIRCUIT IN YAW RATE & LATERAL G SENSOR OUTPUT HARNESS AND GROUND HARNESS. 1) Turn the ignition switch to OFF. 2) Disconnect the connector from the driver's control center differential control module. 3) Measure the resistance between driver's control center differential control module terminals. Connector & terminal (B380) No. 1 — No. 11:	Go to step 9.	Repair the harness connector between yaw rate & lateral G sensor and ABSCM&H/U.

Diagnostic Procedure with Diagnostic Trouble Code (DTC)

ABS (DIAGNOSTICS)

Step	Check	Yes	No
9 CHECK GROUND SHORT OF HARNESS. Measure the resistance between the driver's control center differential control module connector and chassis ground. Connector & terminal (B380) No. 11 — Chassis ground:	Is the resistance 1 MΩ or more?	Go to step 10.	Repair the harness between yaw rate & lateral G sensor and driver's control center differential control module. Replace the driver's control center differential control module. <Ref. to 6MT-122, Driver's Control Center Differential Control Module.>
10 CHECK YAW RATE & LATERAL G SENSOR. 1) Remove the console box. 2) Remove the yaw rate & lateral G sensor from vehicle. 3) Connect the connector to the yaw rate & lateral G sensor. 4) Connect the connector to ABSCM&H/U. 5) Turn the ignition switch to ON. 6) Measure the voltage between yaw rate & lateral G sensor connector terminals. Connector & terminal (B230) No. 5 (+) — (B230) No. 6 (-):	Is the voltage 2.1 — 2.5 V when yaw rate & lateral G sensor is in horizontal position?	Go to step 11.	Replace the yaw rate & lateral G sensor. <Ref. to 6MT-121, Yaw Rate and Lateral G Sensor.>
11 CHECK YAW RATE & LATERAL G SENSOR. Measure the voltage between yaw rate & lateral G sensor connector terminals. Connector & terminal (B230) No. 5 (+) — (B230) No. 6 (-):	Is the voltage 3.3 — 3.7 V when yaw rate & lateral G sensor is inclined 90° to the right?	Go to step 12.	Replace the yaw rate & lateral G sensor. <Ref. to 6MT-121, Yaw Rate and Lateral G Sensor.>
12 CHECK YAW RATE & LATERAL G SENSOR. Measure the voltage between yaw rate & lateral G sensor connector terminals. Connector & terminal (B230) No. 5 (+) — (B230) No. 6 (-):	Is the voltage 0.5 — 0.9 V when yaw rate & lateral G sensor is inclined 90° to the left?	Go to step 13.	Replace the yaw rate & lateral G sensor. <Ref. to 6MT-121, Yaw Rate and Lateral G Sensor.>
13 CHECK ABSCM&H/U. 1) Turn the ignition switch to OFF. 2) Connect all connectors. 3) Erase the memory. 4) Perform the Inspection Mode. 5) Read the DTC.	Is the same DTC still output?	Replace the ABSCM. <Ref. to ABS-6, ABS Control Module and Hydraulic Control Unit (ABSCM&H/U).>	Go to step 14.
14 CHECK OTHER DTC DETECTION.	Is there any other DTC detected?	Perform the diagnosis according to DTC.	Temporary poor contact occurs.

13. General Diagnostic Table

A: INSPECTION

Symptoms		Problem units/parts
Vehicle instability during braking	Vehicle is pulled to either right or left side.	<ul style="list-style-type: none"> • ABSCM&H/U (solenoid valve) • ABS wheel speed sensor • Brake (caliper, piston and pad) • Wheel alignment • Tire specifications, tire wear and air pressures • Incorrect wiring or piping connections • Road surface (uneven, camber)
	Vehicle spins.	<ul style="list-style-type: none"> • ABSCM&H/U (solenoid valve) • ABS wheel speed sensor • Brake (pad) • Tire specifications, tire wear and air pressures • Incorrect wiring or piping connections
Poor brake performance	Long braking/stopping distance	<ul style="list-style-type: none"> • ABSCM&H/U (solenoid valve) • Brake (pad) • Air in brake line • Tire specifications, tire wear and air pressures • Incorrect wiring or piping connections
	Wheel locks.	<ul style="list-style-type: none"> • ABSCM&H/U (solenoid valve, motor) • ABS wheel speed sensor • Incorrect wiring or piping connections
	Brake drag	<ul style="list-style-type: none"> • ABSCM&H/U (solenoid valve) • ABS wheel speed sensor • Master cylinder • Brake (caliper and piston) • Parking brake • Axle & wheels • Brake pedal play
	Long brake pedal stroke	<ul style="list-style-type: none"> • Air in brake line • Brake pedal play
	Vehicle vertical pitching	<ul style="list-style-type: none"> • Suspension play or fatigue (reduced damping) • Incorrect wiring or piping connections • Road surface (uneven)
	Unstable or uneven braking	<ul style="list-style-type: none"> • ABSCM&H/U (solenoid valve) • ABS wheel speed sensor • Brake (caliper, piston and pad) • Tire specifications, tire wear and air pressures • Incorrect wiring or piping connections • Road surface (uneven)
	Excessive pedal vibration	<ul style="list-style-type: none"> • Incorrect wiring or piping connections • Road surface (uneven)
Vibration and/or noise (while driving on slippery roads)	Noise from the ABSCM&H/U	<ul style="list-style-type: none"> • ABSCM&H/U (mount bushing) • ABS wheel speed sensor • Brake line
	Noise from front of vehicle	<ul style="list-style-type: none"> • ABSCM&H/U (mount bushing) • ABS wheel speed sensor • Master cylinder • Brake (caliper, piston, pad and rotor) • Brake line • Brake booster and check valve • Suspension play or fatigue
	Noise from rear of vehicle	<ul style="list-style-type: none"> • ABS wheel speed sensor • Brake (caliper, piston, pad and rotor) • Parking brake • Brake line • Suspension play or fatigue

General Diagnostic Table

ABS (DIAGNOSTICS)

Brought to you by Eris Studios
NOT FOR RESALE