

Brought to you by Eris Studios  
NOT FOR RESALE

# WHEEL AND TIRE SYSTEM

# 1. General Description

## A: SPECIFICATION

### 1. WHEEL AND TIRE SIZE

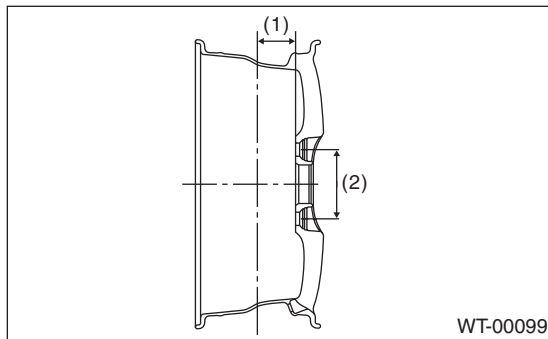

- (1) Offset
- (2) P.C.D.

Specification	Tire size	Wheel size	Offset mm (in)	P.C.D.mm (in)	Tire inflation pressure kPa (kgf/cm <sup>2</sup> , psi)	
					Front wheel	Rear wheel
2.5i, OUTBACK	P205/55R16 89V	16 × 6 1/2JJ	55 (2.17)	100 (3.94)	230 (2.3, 33)	210 (2.1, 30)
WRX	215/45R17 91W	17 × 7JJ	55 (2.17)		230 (2.3, 33)	220 (2.2, 32)
STI	225/45R17 90W	17 × 8JJ	53 (2.09)	114.3 (4.50)	240 (2.4, 35)	200 (2.0, 29)
"T-type" Tire	2.5i, OUTBACK, WRX	T135/70D16 100M	16 × 4T	50 (1.97)	100 (3.94)	420 (4.2, 60)
	STI	T135/70D17 102M	17 × 4T	40 (1.57)	114.3 (4.50)	

**NOTE:**

"T-type" tire for temporary use is equipped as a spare tire.

### 2. SERVICE DATA

Part	Axial runout	Radial runout
Aluminum wheel	1.0 mm (0.039 in)	

**3. ADJUSTING PARTS**

Wheel balancing	Standard:	Service limit
Dynamic unbalance	5 g (0.18 oz) or less	

Balance weight part number (Knock-on type weight for aluminum wheel)	Weight
28101SA000	5 g (0.18 oz)
28101SA010	10 g (0.35 oz)
28101SA020	15 g (0.53 oz)
28101SA030	20 g (0.71 oz)
28101SA040	25 g (0.88 oz)
28101SA100	30 g (1.06 oz)
28101SA110	35 g (1.23 oz)
28101SA120	40 g (1.41 oz)
28101SA130	45 g (1.59 oz)
28101SA140	50 g (1.76 oz)
—	55 g (1.94 oz)
28101SA150	60 g (2.12 oz)

Balance weight part number (Adhesive type weight for aluminum wheel)	Weight
28101AG002	5 g (0.18 oz)
28101AG012	7.5 g (0.26 oz)
28101AG022	10 g (0.35 oz)
28101AG032	12.5 g (0.44 oz)
28101AG042	15 g (0.53 oz)
28101AG052	17.5 g (0.62 oz)
28101AG062	20 g (0.71 oz)
28101AG072	22.5 g (0.79 oz)
28101AG082	25 g (0.88 oz)
28101AG092	27.5 g (0.97 oz)
28101AG102	30 g (1.06 oz)
28101AG112	32.5 g (1.15 oz)
28101AG122	35 g (1.23 oz)
28101AG132	37.5 g (1.32 oz)
28101AG142	40 g (1.41 oz)
28101AG152	42.5 g (1.50 oz)
28101AG162	45 g (1.59 oz)
28101AG172	47.5 g (1.68 oz)
28101AG182	50 g (1.76 oz)
28101AG192	52.5 g (1.85 oz)
28101AG202	55 g (1.94 oz)
28101AG212	57.5 g (2.03 oz)
28101AG222	60 g (2.12 oz)
28101AG232	62.5 g (2.20 oz)
28101AG242	65 g (2.29 oz)
28101AG252	67.5 g (2.38 oz)
28101AG262	70 g (2.47 oz)
28101AG272	72.5 g (2.56 oz)

Balance weight part number (Adhesive type weight for aluminum wheel)	Weight
28101AG282	75 g (2.65 oz)
28101AG292	77.5 g (2.73 oz)
28101AG302	80 g (2.82 oz)
28101AG312	82.5 g (2.91 oz)
28101AG322	85 g (3.00 oz)
28101AG332	87.5 g (3.09 oz)
28101AG342	90 g (3.17 oz)
28101AG352	92.5 g (3.26 oz)
28101AG362	95 g (3.35 oz)
28101AG372	97.5 g (3.44 oz)
28101AG382	100 g (3.53 oz)

**B: PREPARATION TOOL**

**1. GENERAL TOOL**

TOOL NAME	REMARKS
Air pressure gauge	Used for measuring tire air pressure.
Dial gauge	Used for measuring wheel runout.
Wheel balancer	Used for adjusting wheel balance.

## 2. Tire

### A: INSPECTION

- 1) Take stones, glass, nails etc. out of the tread groove.
- 2) Replace tires in the following cases.

#### CAUTION:

**When replacing a tire, make sure to use only tires of the same size, construction and load range as originally installed.**

- (1) If large cracks on side wall, damage or cracks on the tread is found.
- (2) When the "tread wear indicator" appears as a solid band across the tread.

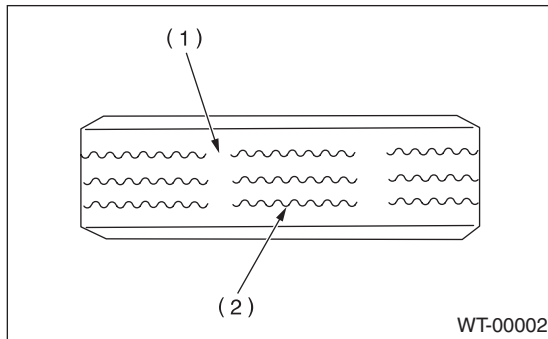

- (1) Tread wear indicator
- (2) Tire tread

- 3) When a crack on tire valve is found, replace the tire valve.

### 1. TIRE ROTATION

Rotate tires periodically (12,500 km/7,500 miles) as shown in the figure, in order to prevent them from uneven wear and to prolong their life.

- When the direction of tire rotation is not specified

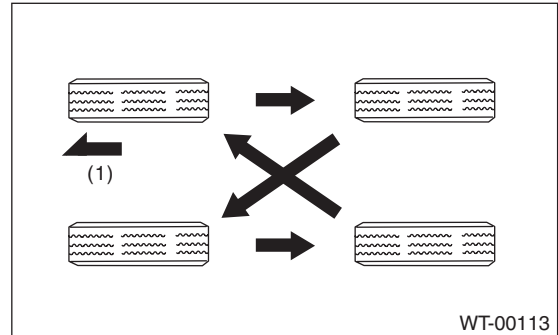

(1) Front

- With instruction for the direction of tire rotation

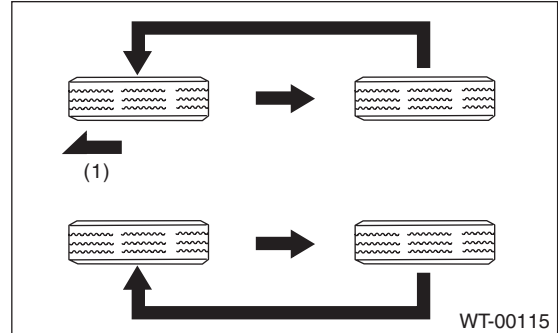

(1) Front

### 3. Aluminum Wheel

#### A: REMOVAL

- 1) Apply the parking brake, and position select lever or shift lever to "P" range (AT model) or "1st gear" (MT model).
- 2) Set the shop jacks or a lift to the specified points, and support the vehicle with its wheels slightly contacting the floor.
- 3) Loosen the wheel nuts.
- 4) Raise the vehicle until its tires are off the ground using the jack or a lift.
- 5) Remove the wheel nuts and wheels.

#### NOTE:

- When removing the wheels, be careful not to damage the hub bolts.
- Place the wheels with their outer sides facing upward to prevent wheels from being damaged.

#### B: INSTALLATION

- 1) Remove dirt from the mating surface of the wheel and brake rotor.
- 2) Attach the wheel to the hub by aligning the wheel bolt holes with the hub bolts.
- 3) Temporarily attach SUBARU genuine wheel nuts to the hub bolts.
- 4) Tighten the nuts by hand, making sure the wheel hub hole is aligned correctly to the guide portion of hub.
- 5) Tighten the wheel nuts in a diagonal selection to the specified torque. Use a wheel nut wrench.

#### *Wheel nut tightening torque:*

**100 N·m (10.2 kgf·m, 73.8 ft·lb)**

#### CAUTION:

- Tighten the wheel nuts diagonally in two or three steps by gradually increasing the torque, until they reach the specified torque.
- Do not push the wrench by foot. Always use both hands when tightening the nuts.
- Make sure the bolt, nut and the nut seating surface of the wheel are free from oil.

- 6) If a wheel is removed for replacement or for repair of a puncture, retighten the wheel nuts to the specified torque after driving 1,000 km (600 miles).

#### C: INSPECTION

- 1) Deformation or damage to the rim may cause air leakage. Check the rim flange for deformation, cracks or damage, and repair or replace as necessary.
- 2) Jack-up the vehicle until tires clear the floor.

- 3) Slowly rotate the wheel to check rim "runout" using a dial gauge.

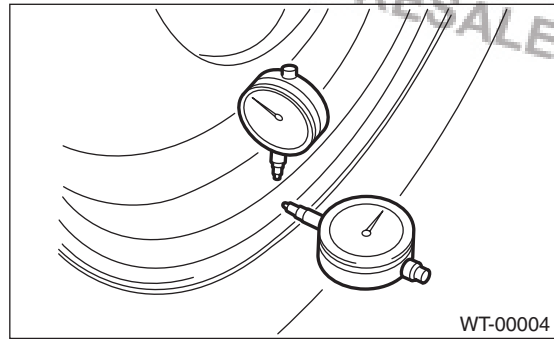

Axial runout limit	Radial runout limit
1.0 mm (0.039 in)	

- 4) If the rim runout exceeds specifications, remove the tire from the rim and check runout with the dial gauge attached to positions shown in the figure.

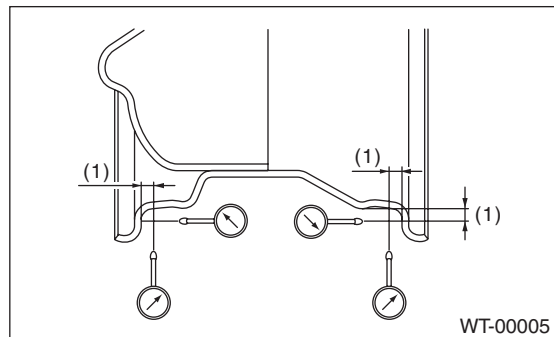

(1) Approx. 7 mm (0.28 in)

- 5) If the measured runout still exceeds specifications, replace the wheel.

#### D: CAUTION

Aluminum wheels are easily scratched. To maintain their appearance and safety, be careful of the following:

- 1) Be careful not to damage the aluminum wheels during removal, installation, wheel balancing, etc. After removing parts, place them on a rubber mat etc.
- 2) When washing the aluminum wheel, use neutral synthetic detergent and water. Avoid using cleansers containing abrasives, hard brushes or an automatic car washer.

## 4. Wheel Balancing

### A: REPLACEMENT

#### 1. KNOCK-ON TYPE WEIGHT

- 1) Remove the balance weights.
- 2) Using the dynamic balancer, measure wheel balance.
- 3) Select a weight close to the value measured by dynamic balancer.

Balance weight part number (Knock-on type weight for aluminum wheel)	Weight
28101SA000	5 g (0.18 oz)
28101SA010	10 g (0.35 oz)
28101SA020	15 g (0.53 oz)
28101SA030	20 g (0.71 oz)
28101SA040	25 g (0.88 oz)
28101SA100	30 g (1.06 oz)
28101SA110	35 g (1.23 oz)
28101SA120	40 g (1.41 oz)
28101SA130	45 g (1.59 oz)
28101SA140	50 g (1.76 oz)
—	55 g (1.94 oz)
28101SA150	60 g (2.12 oz)

- 4) Install the selected weight to the point designated by the dynamic balancer.
- 5) Using the dynamic balancer, measure wheel balance again. Check that wheel balance is correctly adjusted.

#### 2. ADHESIVE TYPE WEIGHT

- 1) Remove the balance weights.
- 2) Remove the double-sided tape remaining on wheels, and clean the adhesive surface.
- 3) Set the wheel on balancer (a knock-on type balancer is available) to measure the unbalance amount.

Balance weight part number (Adhesive type weight for aluminum wheel)	Weight
28101AG002	5 g (0.18 oz)
28101AG012	7.5 g (0.26 oz)
28101AG022	10 g (0.35 oz)
28101AG032	12.5 g (0.44 oz)
28101AG042	15 g (0.53 oz)
28101AG052	17.5 g (0.62 oz)
28101AG062	20 g (0.71 oz)
28101AG072	22.5 g (0.79 oz)
28101AG082	25 g (0.88 oz)
28101AG092	27.5 g (0.97 oz)
28101AG102	30 g (1.06 oz)
28101AG112	32.5 g (1.15 oz)
28101AG122	35 g (1.23 oz)
28101AG132	37.5 g (1.32 oz)
28101AG142	40 g (1.41 oz)
28101AG152	42.5 g (1.50 oz)
28101AG162	45 g (1.59 oz)
28101AG172	47.5 g (1.68 oz)
28101AG182	50 g (1.76 oz)
28101AG192	52.5 g (1.85 oz)
28101AG202	55 g (1.94 oz)
28101AG212	57.5 g (2.03 oz)
28101AG222	60 g (2.12 oz)
28101AG232	62.5 g (2.20 oz)
28101AG242	65 g (2.29 oz)
28101AG252	67.5 g (2.38 oz)
28101AG262	70 g (2.47 oz)
28101AG272	72.5 g (2.56 oz)
28101AG282	75 g (2.65 oz)
28101AG292	77.5 g (2.73 oz)
28101AG302	80 g (2.82 oz)
28101AG312	82.5 g (2.91 oz)
28101AG322	85 g (3.00 oz)
28101AG332	87.5 g (3.09 oz)
28101AG342	90 g (3.17 oz)
28101AG352	92.5 g (3.26 oz)
28101AG362	95 g (3.35 oz)
28101AG372	97.5 g (3.44 oz)
28101AG382	100 g (3.53 oz)

4) Select the closest weight to the calculated value, decrease the adhesive surface designated by the balancer, and apply that weight.

**CAUTION:**

- Press the adhesive part by 25 N·m (2.6 kgf-m, 18 ft-lb) or more per 5 g (0.18 oz) for two seconds or more to attain full adhesion.
- Perform the balance adjustment on outer side first, then on inner side.
- Total application of the weight should be 100 g (3.53 oz) or less.

**B: INSPECTION**

- 1) If the tire has been repaired or worn, correct wheel balance may be lost. Check the tire dynamic balance and repair if necessary.
- 2) Use the dynamic balancer to check dynamic balance. Drive with balance weights applied to both upper and rear side of the rim.
- 3) Some kinds of balancer may damage the wheel. Use an appropriate balancer when adjusting wheel balance.
- 4) Use Subaru genuine balance weights.

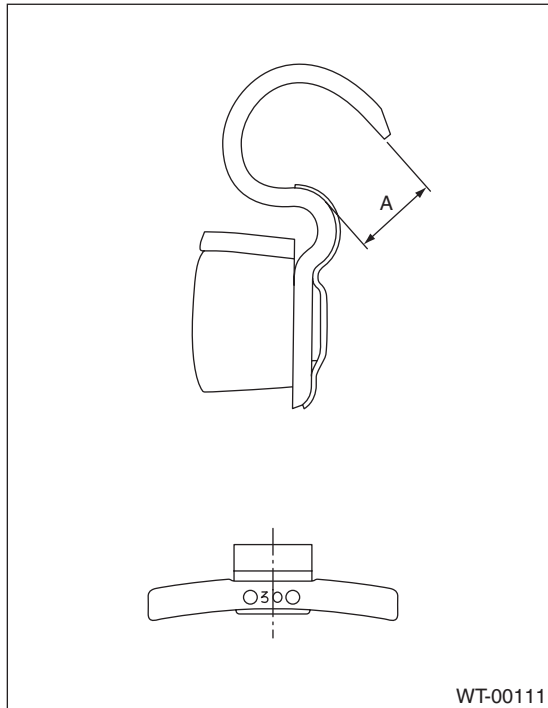

**Service limit A:**  
**5.0 mm (0.20 in)**

Brought to you by Eris Studios  
NOT FOR RESALE

## **5. “T-type” Tire**

### **A: NOTE**

“T-type” tire for temporary use is prepared as a spare tire.

#### **CAUTION:**

- **Do not use tire chains for “T-type Tire”. Because tire size is small, tire chains can not be installed and will damage the vehicle and tires.**
- **Do not drive at a speed greater than 80 km/h (50 MPH).**
- **Drive the vehicle as slowly as possible and avoid bumps on the road.**

### **B: REPLACEMENT**

Refer to “Aluminum Wheel” for removal and installation of the “T-type” tire. <Ref. to WT-5, Aluminum Wheel.>

#### **CAUTION:**

**The “T-type” tire is only for temporary use. Replace with a conventional tire as soon as possible.**

### **C: INSPECTION**

- 1) Check the tire air pressure.

#### **Specifications:**

**420 kPa (4.2 kgf/cm<sup>2</sup>, 60 psi)**

- 2) Take stones, glass, nails, etc. out of the tread groove.
- 3) Check the tires for deformation, cracks, partial wear, or wear.

#### **CAUTION:**

**Replace the tire with a new part.**



**6. General Diagnostic Table**

**A: INSPECTION**

Symptoms	Possible cause	Corrective action
Front wheel abnormal rolling	Tire wear or improper air pressure	Replace the tire in case of tire wear. Adjust air pressure in case of improper air pressure.
	Wheel is out of balance.	Adjust.
Abnormal tire wear	Tire improper air pressure	Replace.
Yawing / pitching	Tire wear or improper air pressure	Replace the tire in case of tire wear. Adjust air pressure in case of improper air pressure.
Yawing / rolling	Tire wear or improper air pressure	Replace the tire in case of tire wear. Adjust air pressure in case of improper air pressure.

# General Diagnostic Table

WHEEL AND TIRE SYSTEM

---

Brought to you by Eris Studios  
NOT FOR RESALE