

Brought to you by Eris Studios
NOT FOR RESALE

IGNITION

General Description

IGNITION

1. General Description

A: SPECIFICATION

Item		Specification	
Ignition coil & ignitor assembly	Type	FH 0286	
	Manufacturer	Diamond Electric	
	Secondary coil resistance	11.2 kΩ±15%	
Spark plug	Manufacturer and type	NGK: FR5AP-11	
	Thread size (diameter, pitch, length)	mm	14,1.25,19
	Spark plug gap	mm (in)	1.0 — 1.1 (0.039 — 0.043)
	Electrode		Platinum

B: COMPONENT

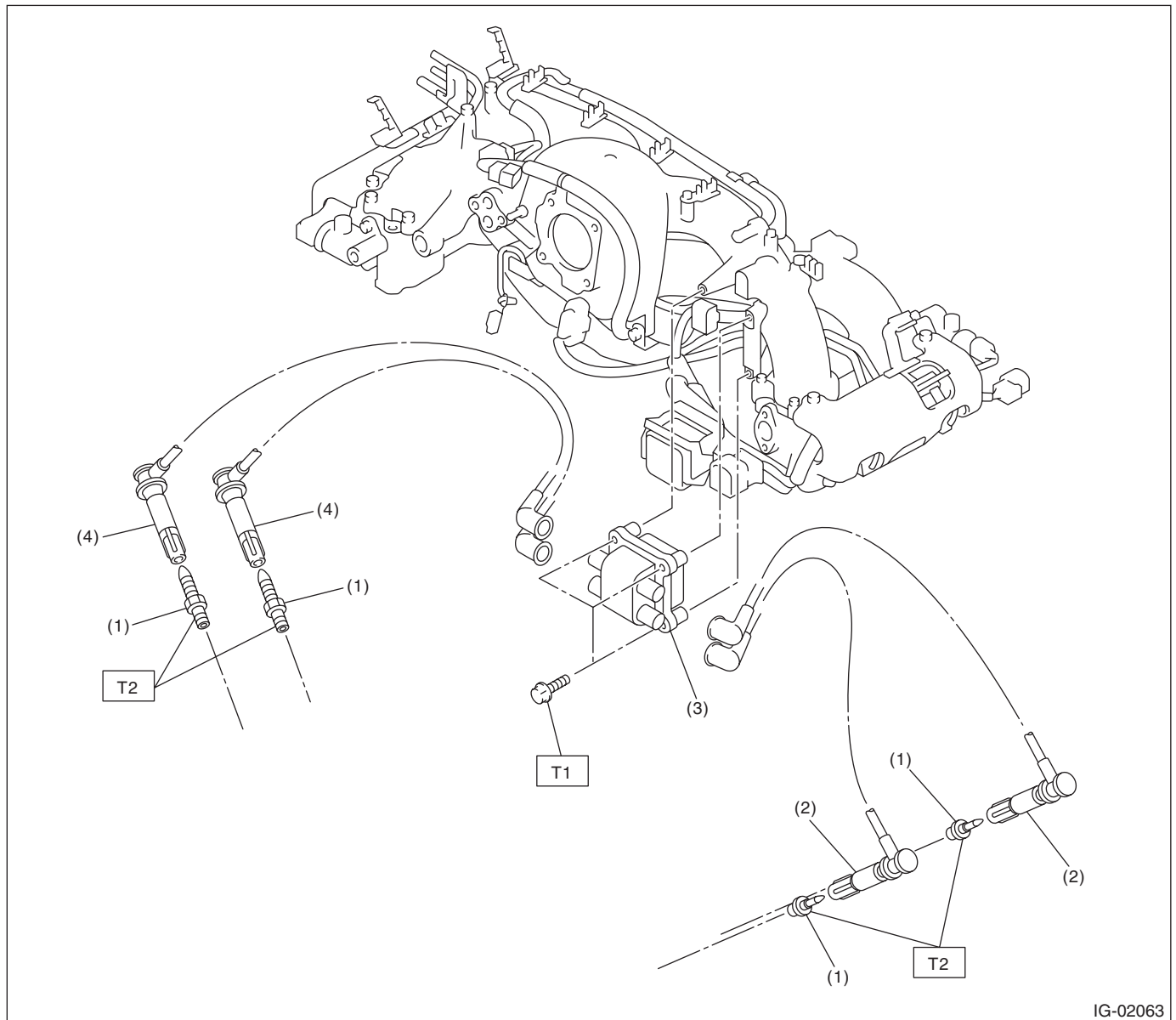

IG-02063

- (1) Spark plug
- (2) Spark plug cord (#1, #3)
- (3) Ignition coil and ignitor ASSY
- (4) Spark plug cord (#2, #4)

Tightening torque: N·m (kgf·m, ft·lb)
T1: 6.4 (0.65, 4.7)
T2: 21 (2.1, 15.2)

C: CAUTION

- Wear appropriate work clothing, including a cap, protective goggles and protective shoes when performing any work.
- Remove contamination including dirt and corrosion before removal, installation or disassembly.
- Keep the disassembled parts in order and protect them from dust and dirt.
- Before removal, installation or disassembly, be sure to clarify the failure. Avoid unnecessary removal, installation, disassembly and replacement.
- Vehicle components are extremely hot after driving. Be wary of receiving burns from heated parts.
- Be sure to tighten fasteners including bolts and nuts to the specified torque.
- Place shop jacks or rigid racks at the specified points.
- Before disconnecting connectors of sensors or units, be sure to disconnect the ground cable from the battery.

2. Spark Plug

A: REMOVAL

Spark plug:

Refer to "SPECIFICATION" for the recommended spark plug. <Ref. to IG(H4SO)-2, SPECIFICATION, General Description.>

1. RH SIDE

- 1) Disconnect the ground cable from the battery.

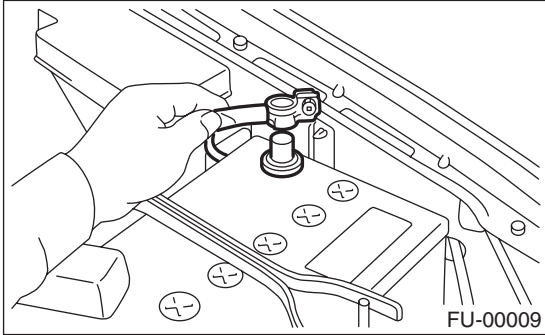

- 2) Remove the air cleaner case. <Ref. to IN(H4SO)-5, REMOVAL, Air Cleaner Case.>

- 3) Remove the spark plug cords by pulling the boot. (Do not pull the cord itself.)

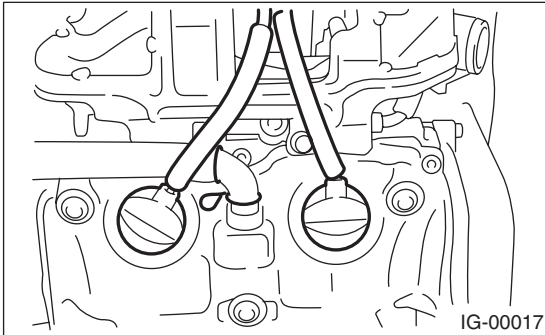

- 4) Remove the spark plug with a spark plug socket.

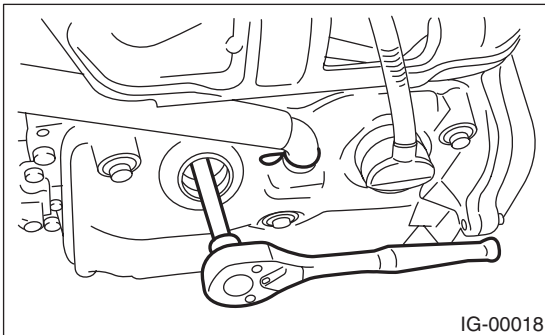

2. LH SIDE

- 1) Remove the battery. <Ref. to SC(H4SO)-20, REMOVAL, Battery.>
- 2) Remove the spark plug cords by pulling the boot. (Do not pull the cord itself.)

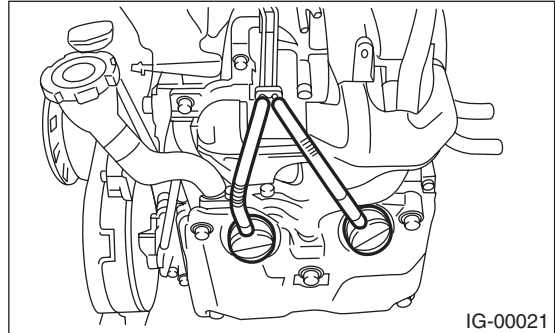

- 3) Remove the spark plug with a spark plug socket.

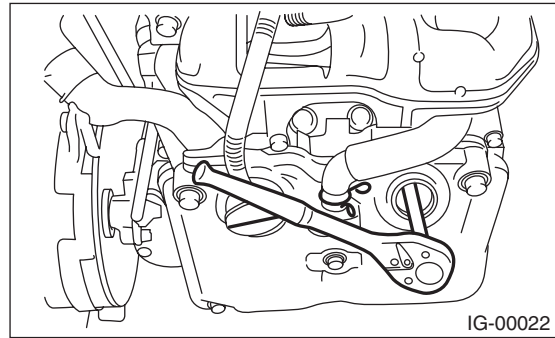

B: INSTALLATION

1. RH SIDE

Install in the reverse order of removal.

Tightening torque:

21 N·m(2.1 kgf-m, 15.2 ft-lb)

2. LH SIDE

Install in the reverse order of removal.

Tightening torque:

21 N·m(2.1 kgf-m, 15.2 ft-lb)

C: INSPECTION

Check the electrodes and inner and outer ceramic insulator of plugs, noting the type of deposits and the degree of electrode erosion.

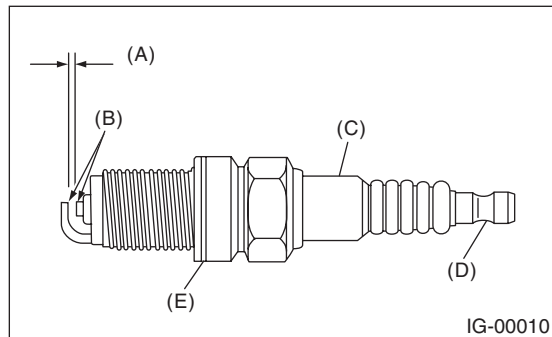

- (A) Spark plug gap
- (B) Carbon accumulation or wear
- (C) Cracks
- (D) Damage
- (E) Damaged gasket

1) Normal:

Brown to grayish-tan deposits and slight electrode wear indicate correct spark plug heat range.

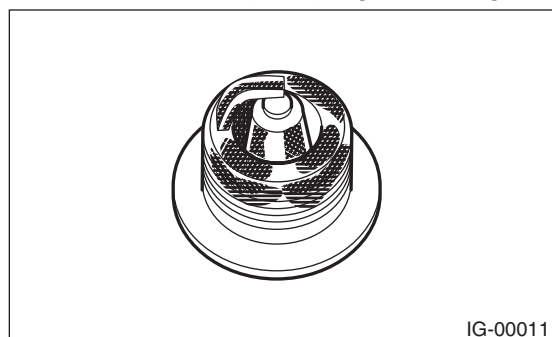

2) Carbon fouled:

Dry fluffy carbon deposits on insulator and electrode are mostly caused by slow speed driving in the city, weak ignition, too rich fuel mixture, dirty air cleaner, etc.

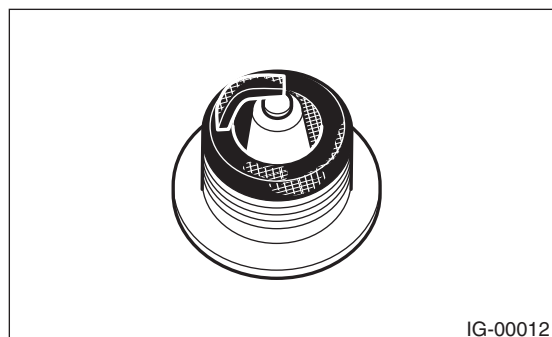

3) Oil fouled:

Wet black deposits show oil entrance into the combustion chamber through worn rings and excessive clearance between valve guides and stems.

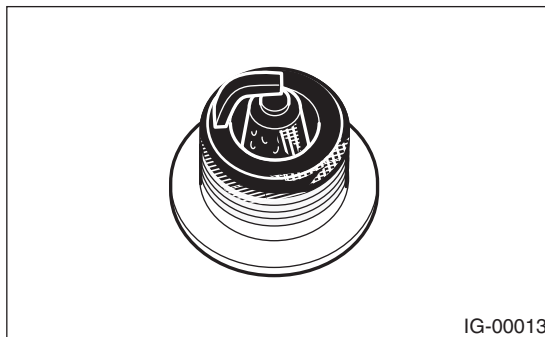

4) Overheating:

White or light gray insulator with black or brown spots and bluish burnt electrodes indicate engine overheating, incorrect ignition timing, wrong selection of fuel, and loose spark plugs.

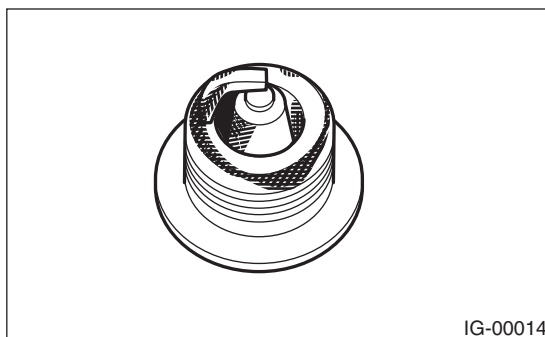

D: ADJUSTMENT

Clean spark plugs with a nylon brush, etc. Clean and remove the carbon or oxide deposits. If deposits are too stubborn, replace the spark plugs. After cleaning the spark plugs, measure the spark plug gap using a gap gauge.

NOTE:

- Never use plug cleaner.
- Do not use metal brush or it will wear insulator.

Spark plug gap L:

1.0 × 1.1 mm (0.039 × 0.043 in)

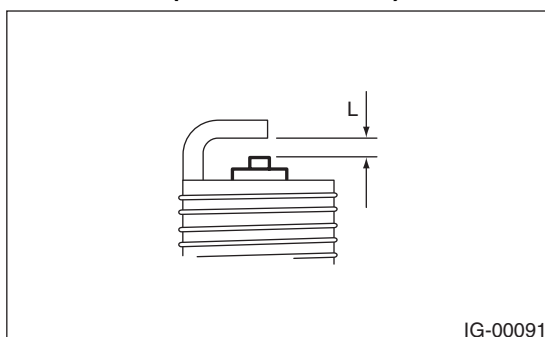

Ignition Coil and Ignitor Assembly

IGNITION

3. Ignition Coil and Ignitor Assembly

A: REMOVAL

1) Disconnect the ground cable from the battery.

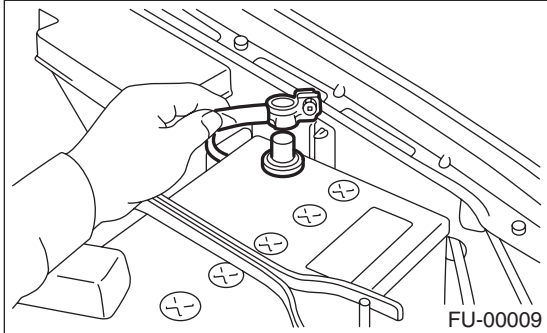

2) Disconnect the spark plug cords from ignition coil and ignitor assembly.

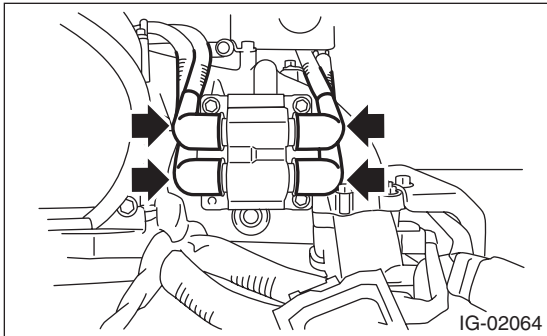

3) Disconnect the connector (A) from ignition coil and ignitor assembly.

4) Remove the bolt (B) which secures the ignition coil and ignitor assembly to the intake manifold.

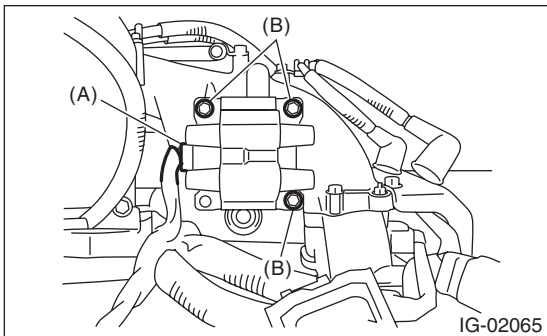

B: INSTALLATION

Install in the reverse order of removal.

Tightening torque:

6.4 N·m (0.65 kgf-m, 4.7 ft-lb)

CAUTION:

Connect the spark plug cords to correct positions. Failure to do so will damage the unit.

C: INSPECTION

Check the secondary coil resistance using a tester. Replace if defective.

CAUTION:

- If the resistance is extremely low, it indicates the presence of a short-circuit.
- Ignitor is integrated with the coil. Therefore the resistance of primary side coil cannot be measured.

Specified resistance:

[Secondary side]

Between (A) and (B)

11.2 kΩ±15%

Between (C) and (D)

11.2 kΩ±15%

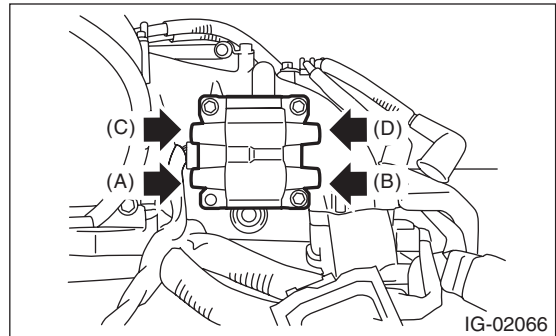

4. Spark Plug Cord

A: INSPECTION

Check the following items.

- Damage to cords, deformation, burning or rust formation of terminals
- Resistance value of cords

Specified resistance:

#1 cord: 7.1 — 12.1 k Ω

#2 cord: 12.1 — 19.9 k Ω

#3 cord: 7.7 — 13.0 k Ω

#4 cord: 12.3 — 20.2 k Ω

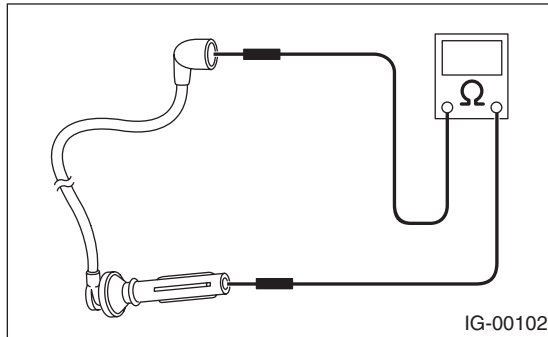

IGNITION

Spark Plug Cord

Brought to you by Eris Studios
NOT FOR RESALE

IG(H4SO)-8