

Brought to you by Eris Studios
NOT FOR RESALE

LUBRICATION

1. General Description

A: SPECIFICATION

Lubrication method			Forced lubrication	
Oil pump	Pump type		Trochoid type	
	Number of teeth	Inner rotor	9	
		Outer rotor	10	
	Outer rotor diameter × thickness		78 × 10 mm (3.07 × 0.39 in)	
	Tip clearance between inner and outer rotors		Standard	0.04 — 0.14 mm (0.0016 — 0.0055 in)
			Limit	0.18 mm (0.0071 in)
	Side clearance between inner rotor and pump case		Standard	0.02 — 0.07 mm (0.0008 — 0.0028 in)
			Limit	0.12 mm (0.0047 in)
	Case clearance between outer rotor and pump case		Standard	0.10 — 0.175 mm (0.0039 — 0.0069 in)
			Limit	0.20 mm (0.0079 in)
Performance (Oil temperature 80°C (176°F))	600 rpm	Discharge pressure	98 kPa (1.0 kgf/cm ² , 14 psi)	
		Discharge rate	4.6 ℓ (4.9 US qt, 4.0 Imp qt)/min.	
	5,000 rpm	Discharge pressure	294 kPa (3.0 kgf/cm ² , 43 psi)	
		Discharge rate	47 ℓ (49.7 US qt, 41.4 Imp qt)/min.	
Relief valve working pressure			588 kPa (6.0 kgf/cm ² , 85 psi)	
Oil filter	Filter type		Full-flow filter type	
	Filtration area	Outer diameter: 65 mm (2.56 in)	470 cm ² (73 sq in)	
		Outer diameter: 68 mm (2.68 in)	800 cm ² (124 sq in)	
	By-pass valve opening pressure		160 kPa (1.63 kgf/cm ² , 23.2 psi)	
	Outer diameter × width	Outer diameter: 65 mm (2.56 in)	65 × 74.4 mm (2.56 × 2.93 in)	
		Outer diameter: 68 mm (2.68 in)	68 × 65 mm (2.68 × 2.56 in)	
Installation screw specifications		M 20 × 1.5		
Oil pressure switch	Type		Immersed contact point type	
	Operating voltage — number of watts		12 V — 3.4 W or less	
	Warning light operating pressure		14.7 kPa (0.15 kgf/cm ² , 2.1 psi)	
	Proof pressure		981 kPa (10 kgf/cm ² , 142 psi) or more	
Engine oil	Total capacity (Overhaul)		5.0 ℓ (5.4 US qt, 4.5 Imp qt)	
	When replacing engine oil and oil filter		4.2 ℓ (4.4 US qt, 3.7 Imp qt)	
	When replacing engine oil only		4.0 ℓ (4.2 US qt, 3.5 Imp qt)	

Recommended oil:

Those with an API standard SM “Energy Conserving” logo.

ILSAC standard GF-4 “starburst mark” displayed on container top.

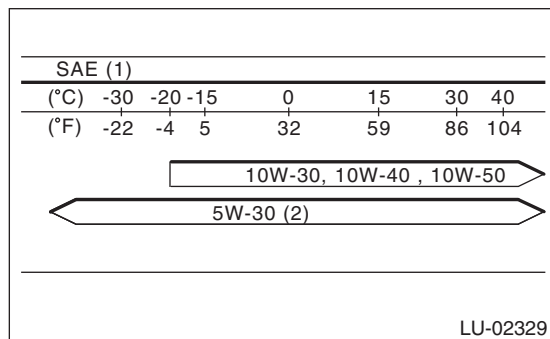

- (1) SAE viscosity No. and applicable temperature
- (2) Recommended

CAUTION:

It is acceptable to fill an engine with oil of another brand when replacing the oil, but make sure to use an oil with an API standard and SAE viscosity number specified by Subaru.

NOTE:

If the vehicle is used in regions of high temperatures or in other severe environments, use oil with the viscosities shown below. API standard: SM or SL
SAE Viscosity No.: 30, 40, 10W-50, 20W-40, 20W-50

B: COMPONENT

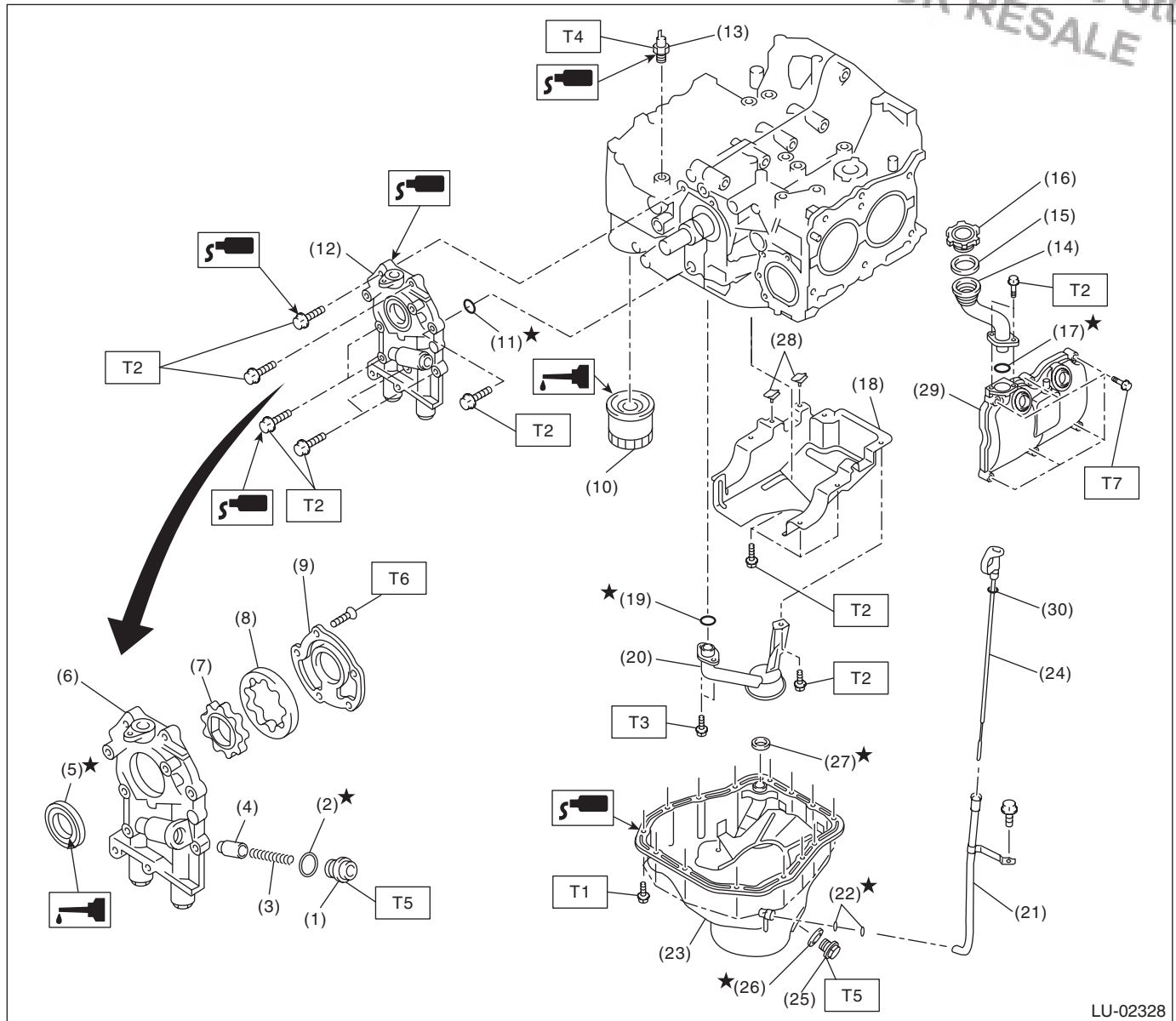

LU-02328

- | | |
|--------------------------|----------------------------|
| (1) Plug | (15) Gasket |
| (2) Gasket | (16) Oil filler cap |
| (3) Relief valve spring | (17) O-ring |
| (4) Relief valve | (18) Baffle plate |
| (5) Oil seal | (19) O-ring |
| (6) Oil pump case | (20) Oil strainer |
| (7) Inner rotor | (21) Oil level gauge guide |
| (8) Outer rotor | (22) O-ring |
| (9) Oil pump cover | (23) Oil pan |
| (10) Oil filter | (24) Oil level gauge |
| (11) O-ring | (25) Drain plug |
| (12) Oil pump ASSY | (26) Metal gasket |
| (13) Oil pressure switch | (27) Gasket |
| (14) Oil filler duct | |

- | |
|-------------------|
| (28) Seal |
| (29) Rocker cover |
| (30) O-ring |

Tightening torque: N·m (kgf·m, ft·lb)

- T1: 5 (0.5, 3.6)**
T2: 6.4 (0.65, 4.7)
T3: 10 (1.0, 7.2)
T4: 25 (2.5, 18.1)
T5: 44 (4.5, 32.5)
T6: 5.4 (0.55, 4.0)
T7: <Ref. to ME(H4SO)-55, INSTALLATION, Camshaft.>

C: CAUTION

- Wear appropriate work clothing, including a cap, protective goggles and protective shoes when performing any work.
- Remove contamination including dirt and corrosion before removal, installation or disassembly.
- Keep the disassembled parts in order and protect them from dust and dirt.
- Before removal, installation or disassembly, be sure to clarify the failure. Avoid unnecessary removal, installation, disassembly and replacement.
- Vehicle components are extremely hot after driving. Be wary of receiving burns from heated parts.
- Be sure to tighten fasteners including bolts and nuts to the specified torque.
- Place shop jacks or rigid racks at the specified points.
- Before disconnecting connectors of sensors or units, be sure to disconnect the ground cable from the battery.

D: PREPARATION TOOL

1. SPECIAL TOOL

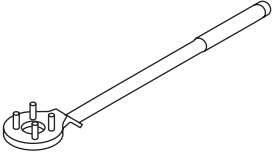
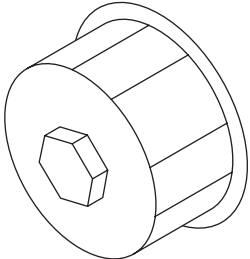
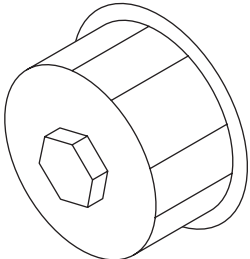
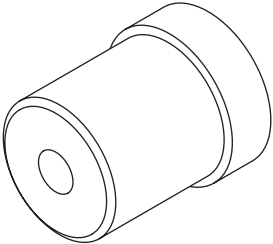
ILLUSTRATION	TOOL NUMBER	DESCRIPTION	REMARKS
 <p data-bbox="337 625 467 646">ST-499977100</p>	499977100	CRANK PULLEY WRENCH	Used for stopping rotation of crank pulley when loosening and tightening the crank pulley bolt.
 <p data-bbox="326 976 467 997">ST18332AA000</p>	18332AA000	OIL FILTER WRENCH	Used for removing and installing oil filter. (Outer diameter: 68 mm (2.68 in))
 <p data-bbox="326 1327 467 1348">ST18332AA010</p>	18332AA010	OIL FILTER WRENCH	Used for removing and installing oil filter. (Outer diameter: 65 mm (2.56 in))
 <p data-bbox="337 1680 467 1701">ST-499587100</p>	499587100	OIL SEAL INSTALLER	Used for installing oil seal into oil pump.

2. Oil Pressure System

A: WIRING DIAGRAM

Brought to you by Eris Studios
NOT FOR RESALE

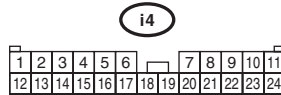
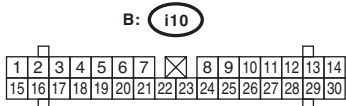
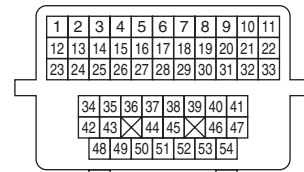
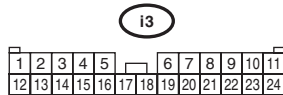
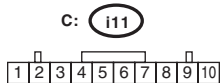
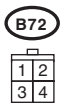
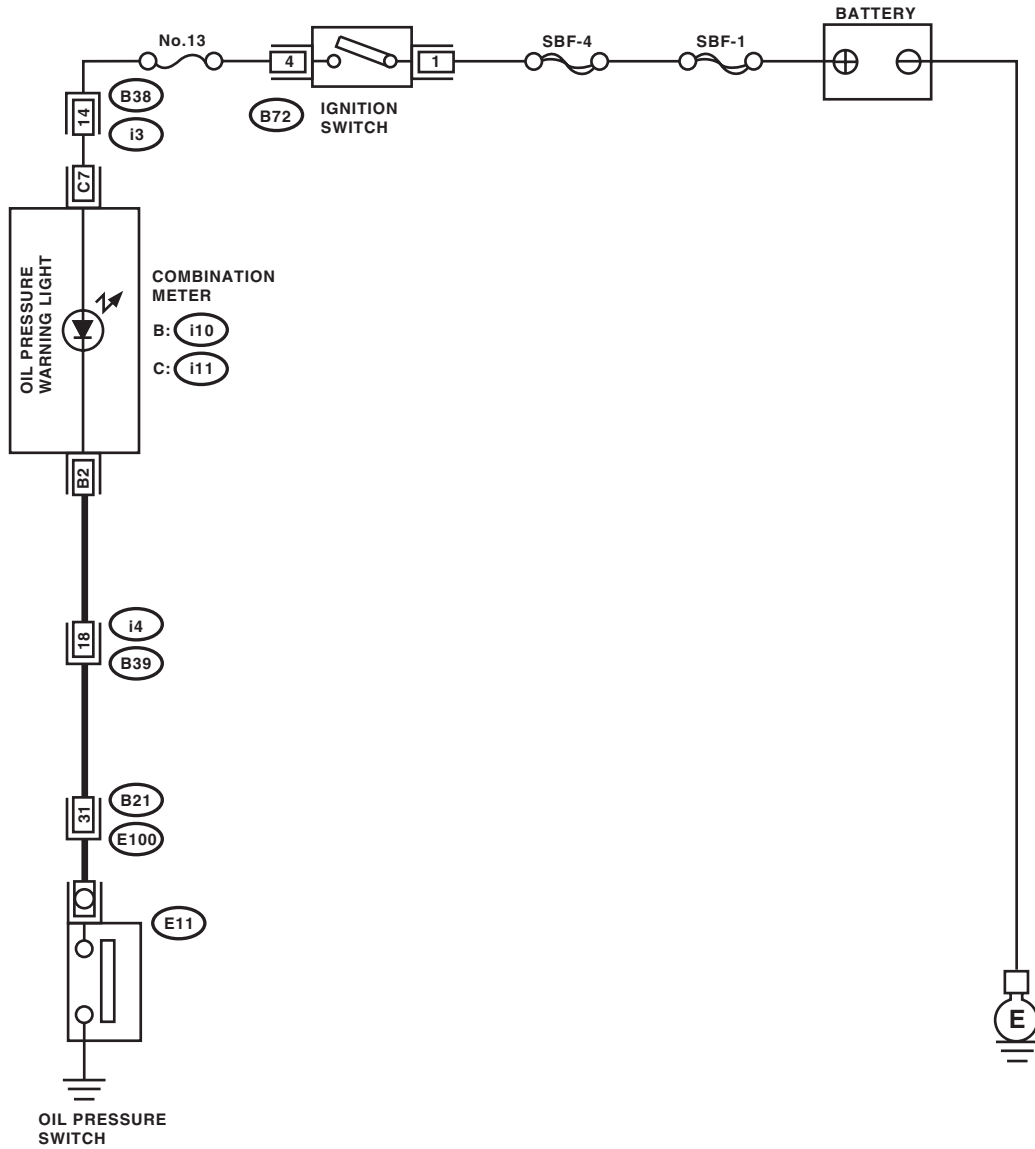

LU-02241

B: INSPECTION

Step	Check	Yes	No
1 CHECK COMBINATION METER. 1) Turn the ignition switch to ON (engine OFF). 2) Check other warning lights.	Does the warning light illuminate?	Go to step 2.	Repair or replace the combination meter. <Ref. to IDI-3, INSPECTION, Combination Meter System.>
2 CHECK HARNESS CONNECTOR BETWEEN COMBINATION METER AND OIL PRESSURE SWITCH. 1) Turn the ignition switch to OFF. 2) Disconnect the connector from oil pressure switch. 3) Turn the ignition switch to ON. 4) Measure the voltage of harness between oil pressure switch connector and chassis ground. Connector & terminal (E11) No. 1 (+) — Chassis ground (-):	Is the voltage 10 V or more?	Replace the oil pressure switch.	Go to step 3.
3 CHECK COMBINATION METER. 1) Turn the ignition switch to OFF. 2) Remove the combination meter. 3) Measure the resistance of combination meter. Terminals (i11) No. 7 — (i10) No. 2:	Is the resistance less than 10 Ω ?	Repair the harness and connector. NOTE: In this case, repair the following item: <ul style="list-style-type: none"> • Open circuit of harness between combination meter and oil pressure switch • Poor contact in combination meter connector • Poor contact in oil pressure switch connector • Poor contact in coupling connector 	Repair or replace the combination meter. <Ref. to IDI-3, INSPECTION, Combination Meter System.>

3. Engine Oil

A: INSPECTION

- 1) Park the vehicle on a level surface.
- 2) Remove the oil level gauge and wipe away the oil.
- 3) Reinsert the oil level gauge all the way. Be sure that the oil level gauge is correctly inserted and properly orientated.
- 4) Pull out the oil level gauge again and check the reading. If the engine oil level is below "L" line, add oil to bring the level up to "F" line.
- 5) After turning off the engine, wait a few minutes for the oil to return to the oil pan before checking the level.
- 6) Just after driving or while the engine is warm, engine oil level shows in the range between "F" line and cutout portion. This is caused by thermal expansion of engine oil.

NOTE:

To prevent overfilling of engine oil, do not add oil above "F" line when the engine is cold.

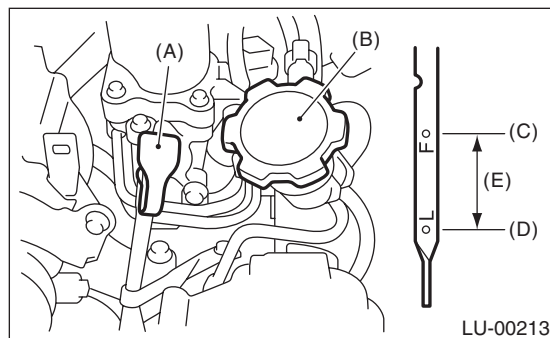

- (A) Oil level gauge
- (B) Engine oil filler cap
- (C) "F" line
- (D) "L" line
- (E) Approx. 1.0 ℓ (1.1 US qt, 0.9 Imp qt)

B: REPLACEMENT

- 1) Set the vehicle on a lift.
- 2) Open the engine oil filler cap for quick draining of engine oil.
- 3) Lift up the vehicle.
- 4) Drain engine oil by loosening the engine oil drain plug.

NOTE:

Prepare the container for draining of engine oil.

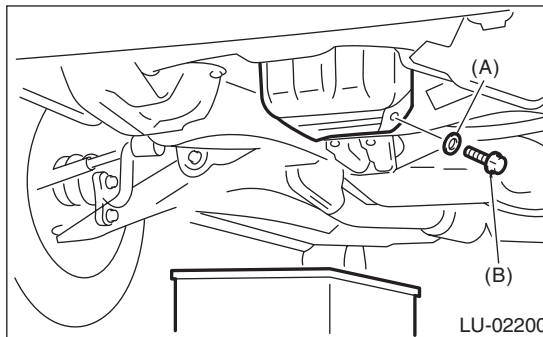

- (A) Gasket
- (B) Drain plug

- 5) Tighten the engine oil drain plug after draining engine oil.

NOTE:

Use a new drain plug gasket.

Tightening torque:

44 N·m (4.5 kgf-m, 32.5 ft-lb)

- 6) Lower the vehicle.
- 7) Using engine oil of proper quality and viscosity, fill engine oil through the oil filler duct to the "F" line on level gauge. Make sure that the vehicle is parked on a level surface when checking oil level.

Recommended oil:

Refer to "SPECIFICATION" for the recommended oil. <Ref. to LU(H4SO)-2, SPECIFICATION, General Description.>

Engine oil capacity:

Refer to "SPECIFICATION" for the engine oil capacity. <Ref. to LU(H4SO)-2, SPECIFICATION, General Description.>

- 8) Close the engine oil filler cap.
- 9) Start the engine and warm it up for a time.
- 10) After the engine stops, recheck the oil level. If necessary, add engine oil up to the "F" line on level gauge.

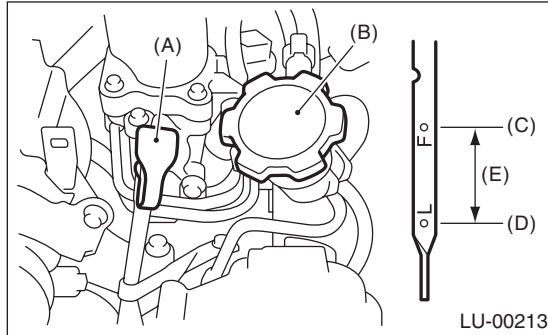

- (A) Oil level gauge
- (B) Engine oil filler cap
- (C) "F" line
- (D) "L" line
- (E) Approx. 1.0 ℓ (1.1 US qt, 0.9 Imp qt)

4. Oil Pump

A: REMOVAL

- 1) Set the vehicle on a lift.
- 2) Disconnect the ground cable from the battery.

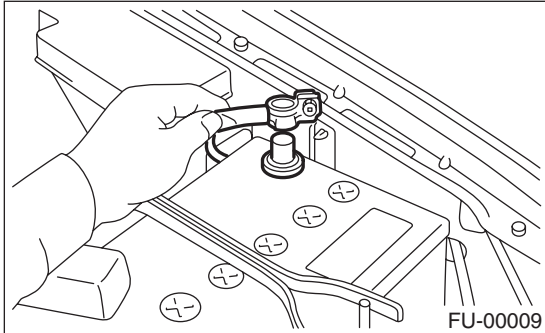

- 3) Lift up the vehicle.
- 4) Remove the under cover.
- 5) Lower the vehicle.
- 6) Remove the radiator. <Ref. to CO(H4SO)-23, REMOVAL, Radiator.>
- 7) Remove the V-belts. <Ref. to ME(H4SO)-39, REMOVAL, V-belt.>
- 8) Remove the belt tensioner.

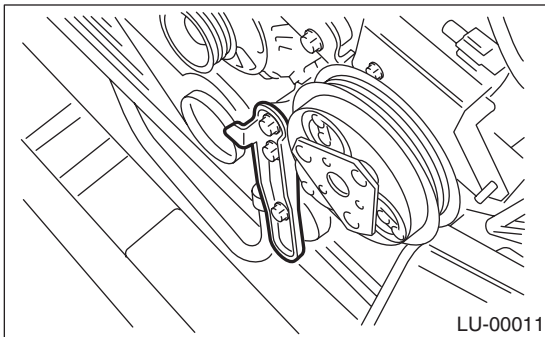

- 9) Remove the crankshaft position sensor.

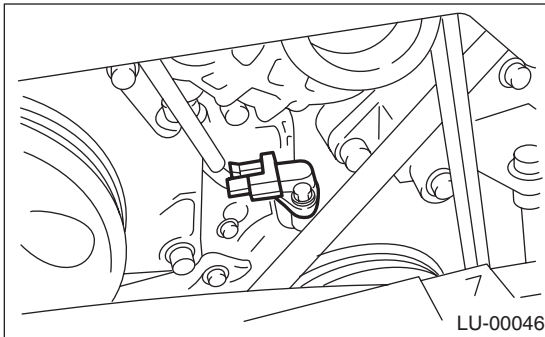

- 10) Remove the crank pulley using ST. ST 499977100 CRANK PULLEY WRENCH

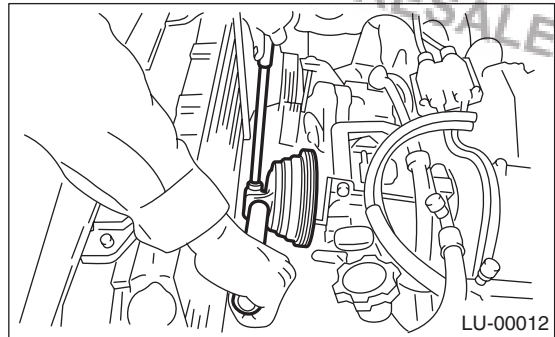

- 11) Remove the water pump. <Ref. to CO(H4SO)-18, REMOVAL, Water Pump.>
- 12) Remove the timing belt guide. (MT model)

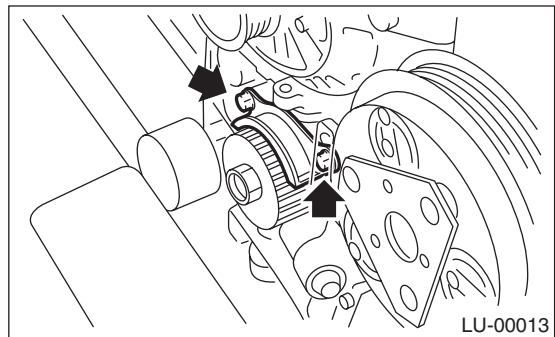

- 13) Remove the crank sprocket.

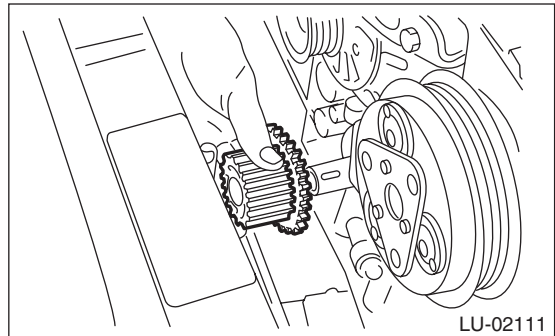

- 14) Remove the bolts which install oil pump onto cylinder block.

NOTE:

When disassembling and checking the oil pump, loosen the relief valve plug before removing the oil pump.

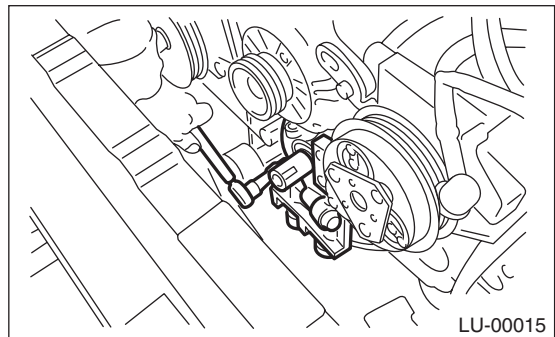

15) Remove the oil pump by using flat tip screwdriver.

CAUTION:

Be careful not to scratch mating surfaces of cylinder block and oil pump.

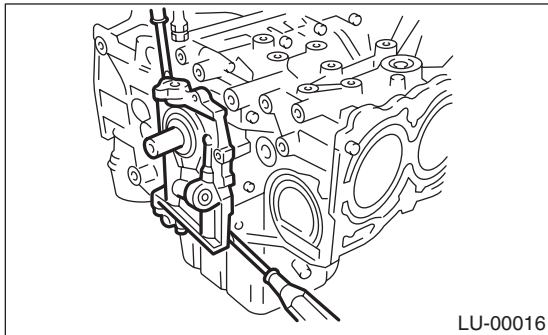

LU-00016

B: INSTALLATION

Install in the reverse order of removal. Perform the following.

1) Using the ST, install the front oil seal.

NOTE:

Use a new front oil seal.

ST 499587100 OIL SEAL INSTALLER

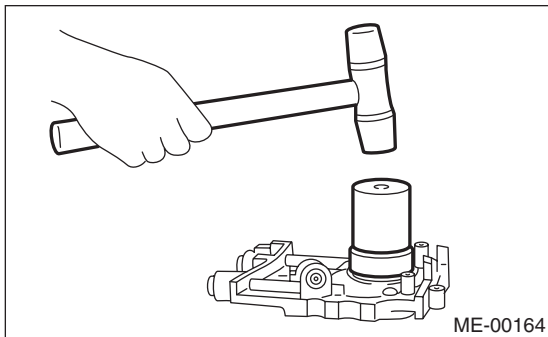

ME-00164

2) Apply liquid gasket to the mating surfaces of oil pump.

Liquid gasket:

THREE BOND 1215 (Part No. 004403007) or equivalent

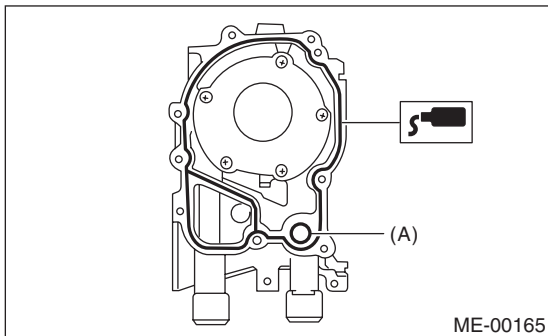

ME-00165

(A) O-ring

3) Apply a coat of engine oil to the inside of oil seal.

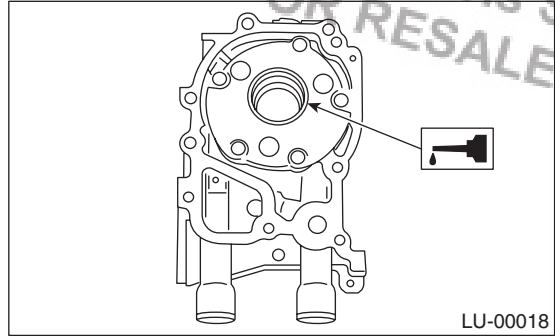

LU-00018

4) Be careful not to scratch the oil seal when installing oil pump on cylinder block.

NOTE:

- Make sure the oil seal lip is not folded.
- Align the flat surface of oil pump's inner rotor with crankshaft before installation.
- Use a new O-ring and oil seal.
- When disassembly and check of the oil pump was performed, tighten the relief valve plug after attaching the oil pump.

Tightening torque:

44 N·m (4.5 kgf·m, 32.5 ft·lb)

5) Apply liquid gasket to the three bolts thread shown in figure. (When reusing the bolts)

Liquid gasket:

THREE BOND 1324 (Part No. 004403042) or equivalent

Tightening torque:

6.4 N·m (0.65 kgf·m, 4.7 ft·lb)

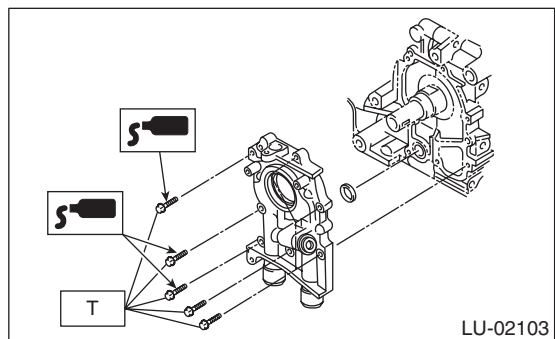

LU-02103

C: DISASSEMBLY

Remove the screw which secures oil pump cover and then disassemble oil pump. Inscribe alignment marks on the inner and outer rotors so that they can be replaced in their original positions during reassembly.

NOTE:

Before disassembling the oil pump, remove the relief valve.

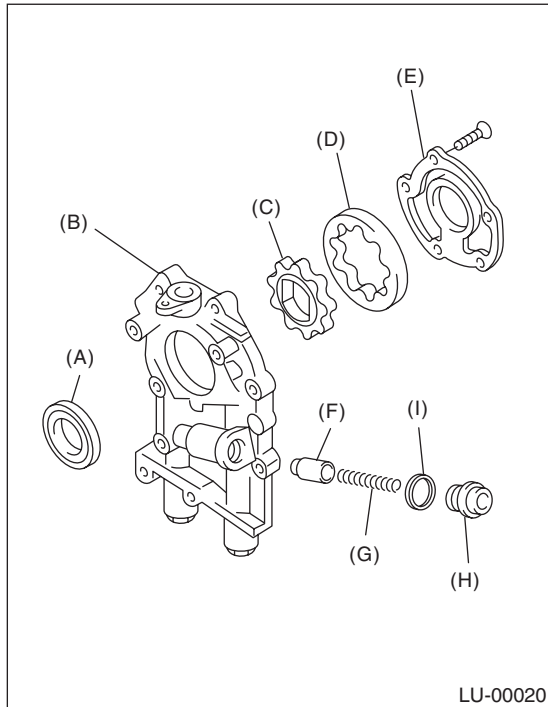

- (A) Oil seal
- (B) Oil pump case
- (C) Inner rotor
- (D) Outer rotor
- (E) Oil pump cover
- (F) Relief valve
- (G) Relief valve spring
- (H) Plug
- (I) Gasket

D: ASSEMBLY

- 1) Assemble the front oil seal by using ST.

NOTE:

Use a new front oil seal.

ST 499587100 OIL SEAL INSTALLER

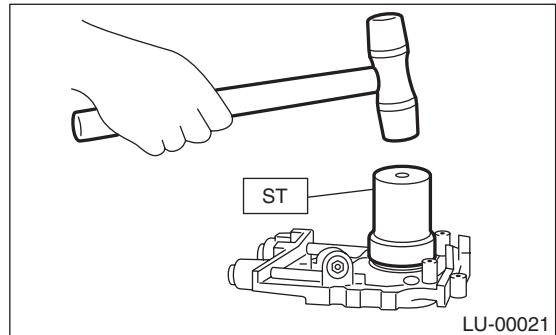

- 2) Apply a coat of engine oil to inner and outer rotors.
- 3) Assemble the inner and outer rotors in their original positions.
- 4) Assemble the oil relief valve and install relief valve spring and plug.

NOTE:

Use a new gasket.

5) Assemble the oil pump cover.

Tightening torque:

T1: 5.4 N·m (0.55 kgf·m, 4.0 ft·lb)

T2: 44 N·m (4.5 kgf·m, 32.5 ft·lb)

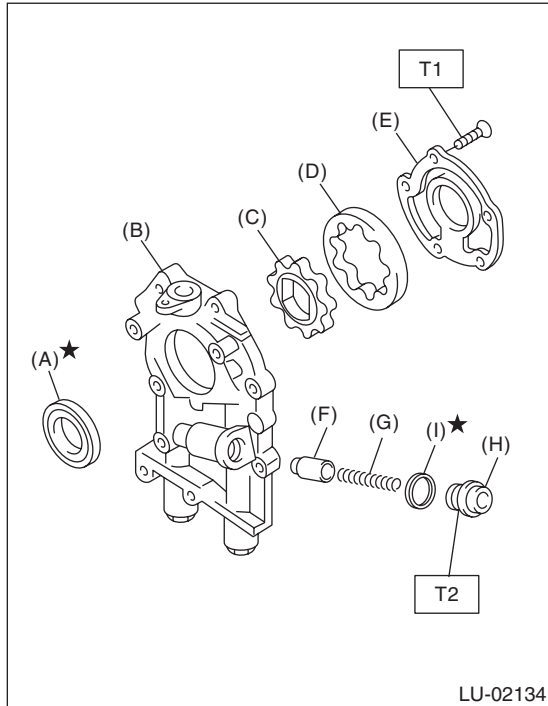

- (A) Oil seal
- (B) Oil pump case
- (C) Inner rotor
- (D) Outer rotor
- (E) Oil pump cover
- (F) Relief valve
- (G) Relief valve spring
- (H) Plug
- (I) Gasket

E: INSPECTION

1. TIP CLEARANCE

Measure the tip clearance of rotors. If the clearance exceeds the limit, replace rotors as a matched set.

Tip clearance:

Standard

0.04 — 0.14 mm (0.0016 — 0.0055 in)

Limit

0.18 mm (0.0071 in)

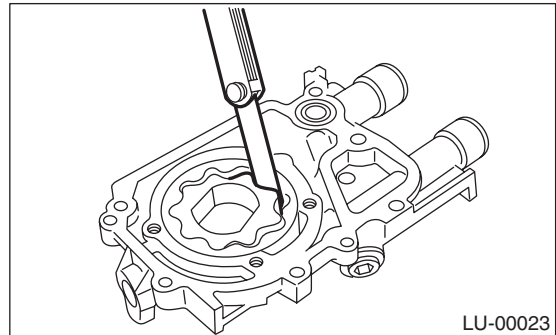

2. CASE CLEARANCE

Measure the clearance between outer rotor and oil pump case. If the clearance exceeds the limit, replace the rotor.

Case clearance:

Standard

0.10 — 0.175 mm (0.0039 — 0.0069 in)

Limit

0.20 mm (0.0079 in)

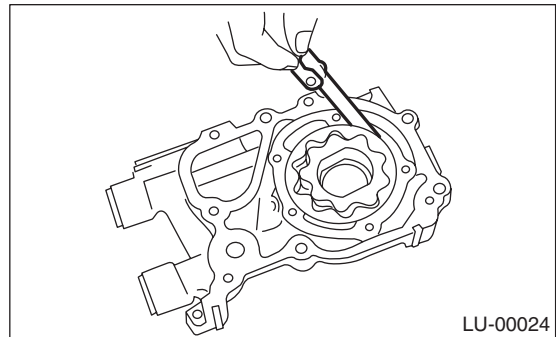

3. SIDE CLEARANCE

Measure the clearance between oil pump inner rotor and oil pump case. If the clearance exceeds the limit, replace rotor or oil pump case.

Side clearance:

Standard

0.02 — 0.07 mm (0.0008 — 0.0028 in)

Limit

0.12 mm (0.0047 in)

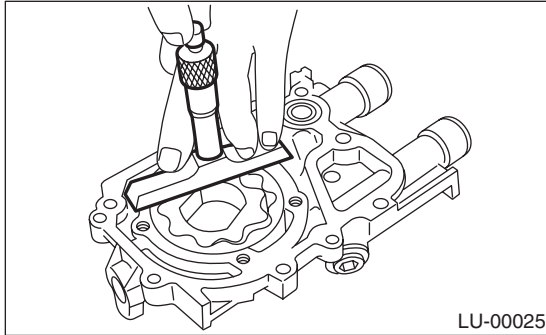

4. OIL RELIEF VALVE

Check the valve for poor assembly condition and damage, and the relief valve spring for damage and deterioration. Replace the parts if defective.

Relief valve spring:

Free length

73.7 mm (2.902 in)

Installed length

54.7 mm (2.154 in)

Load when installed

93.1 N (9.49 kgf, 20.88 lbf)

5. OIL PUMP CASE

Check for worn shaft holes, clogged oil passages, cracks and other faults.

6. OIL SEAL

Check the oil seal lips for deformation, hardening, wear, etc. and replace if defective.

5. Oil Pan and Strainer

A: REMOVAL

- 1) Set the vehicle on a lift.
- 2) Remove the front wheels.
- 3) Disconnect the ground cable from the battery.

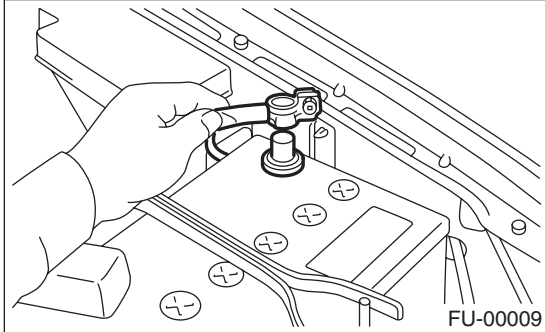

- 4) Remove the air intake duct and air cleaner case. <Ref. to IN(H4SO)-7, REMOVAL, Air Intake Duct.> <Ref. to IN(H4SO)-5, REMOVAL, Air Cleaner Case.>
- 5) Remove the resonator chamber. <Ref. to IN(H4SO)-8, REMOVAL, Resonator Chamber.>
- 6) Remove the pitching stopper.

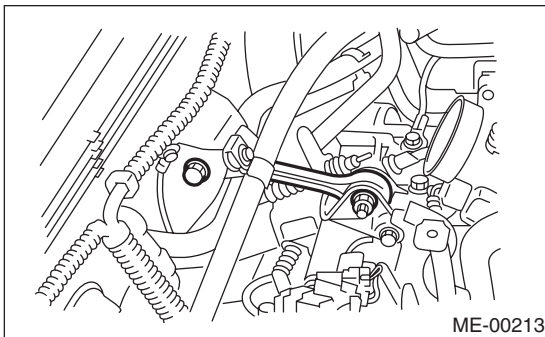

- 7) Remove the radiator upper brackets.

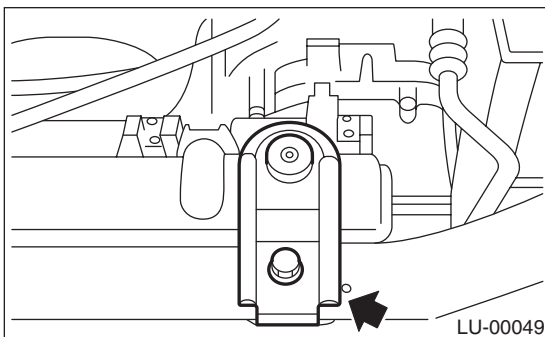

- 8) Support the engine with a lifting device and wire ropes.

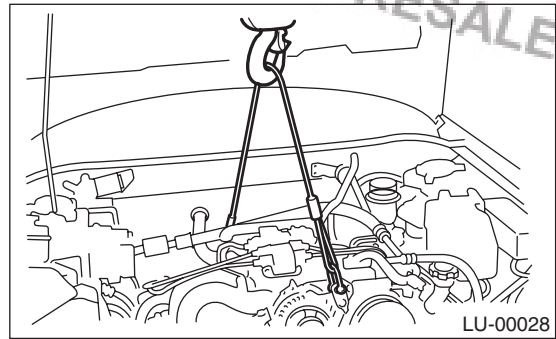

- 9) Lift up the vehicle.

CAUTION:

When lifting up the vehicle, raise up wire ropes at the same time.

- 10) Remove the under cover.
- 11) Drain the engine oil. <Ref. to LU(H4SO)-8, REPLACEMENT, Engine Oil.>
- 12) Remove the front and center exhaust pipes. <Ref. to EX(H4SO)-4, REMOVAL, Front Exhaust Pipe.>
- 13) Remove the nuts which install front cushion rubber onto front crossmember.

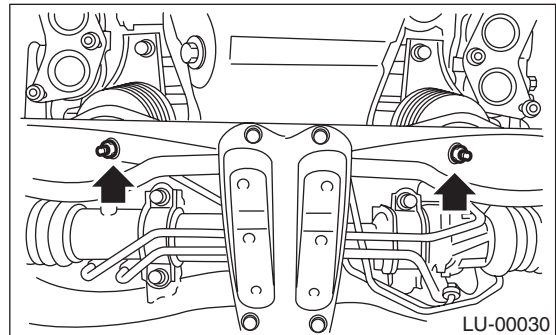

- 14) Remove the bolts which install oil pan on cylinder block with the engine raised up.
- 15) Insert the oil pan cutter blade into the gap between cylinder block and oil pan.

CAUTION:

Do not use a screwdriver or similar tool in place of oil pan cutter.

- 16) Remove the oil strainer.

Oil Pan and Strainer

LUBRICATION

17) Remove the baffle plate.

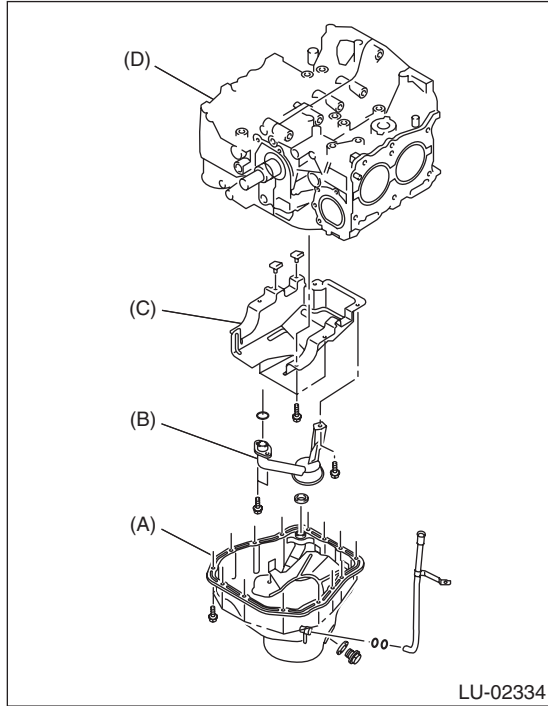

- (A) Oil pan
- (B) Oil strainer
- (C) Baffle plate
- (D) Cylinder block

B: INSTALLATION

NOTE:

Before installing the oil pan, clean the mating surface of oil pan and engine block.

1) Make sure that the seals (A) are installed securely on the baffle plate in a direction as shown in the figure below.

NOTE:

Use new seals.

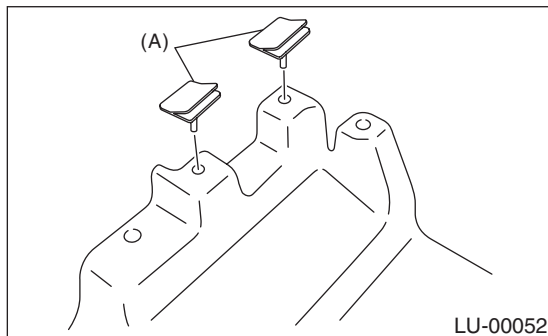

2) Install the baffle plate.

Tightening torque:

6.4 N·m (0.65 kgf-m, 4.7 ft-lb)

3) Install the oil strainer to the baffle plate.

NOTE:

Use new O-rings.

Tightening torque:

10 N·m (1.0 kgf-m, 7.2 ft-lb)

4) Tighten the oil strainer stay together with the baffle plate.

Tightening torque:

6.4 N·m (0.65 kgf-m, 4.7 ft-lb)

5) Apply liquid gasket to the mating surfaces, and install the oil pan.

NOTE:

Install within 5 min. after applying liquid gasket.

Liquid gasket:

THREE BOND 1207C (Part No. 004403012) or equivalent

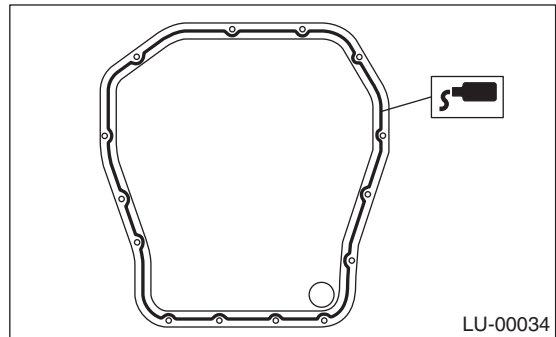

6) Tighten the bolts which secure the oil pan to the engine block.

Tightening torque:

- T1: 5 N·m (0.5 kgf-m, 3.6 ft-lb)**
- T2: 6.4 N·m (0.5 kgf-m, 4.7 ft-lb)**
- T3: 10 N·m (1.0 kgf-m, 7.2 ft-lb)**

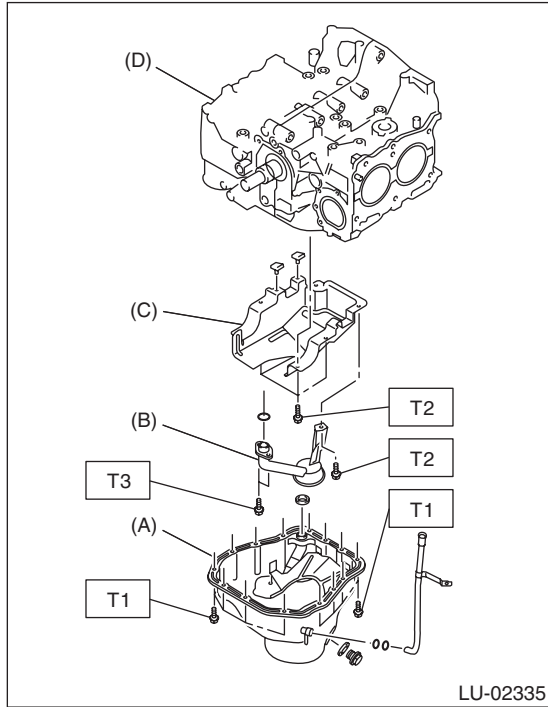

- (A) Oil pan
- (B) Oil strainer
- (C) Baffle plate
- (D) Cylinder block

7) Lower the engine onto front crossmember.
 8) Tighten the nuts which install front cushion rubber onto front crossmember.

Tightening torque:

85 N·m (8.7 kgf-m, 63 ft-lb)

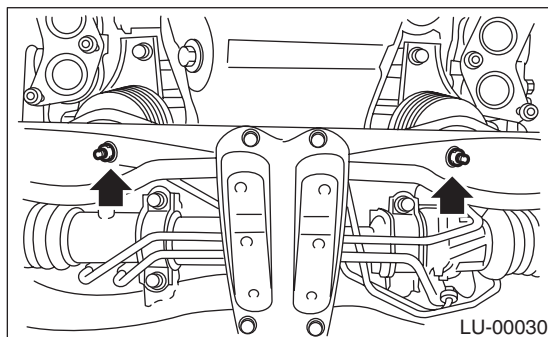

9) Install the front and center exhaust pipe.
 <Ref. to EX(H4SO)-5, INSTALLATION, Front Exhaust Pipe.>

10) Install the under cover.
 11) Lower the vehicle.

CAUTION:

When lowering the vehicle, lower the lift-up device and wire ropes at the same time.

12) Remove the lifting device and wire ropes.

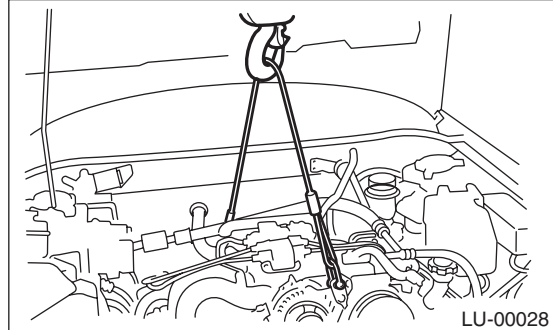

13) Install the pitching stopper.

Tightening torque:

- T1: 50 N·m (5.1 kgf-m, 36.9 ft-lb)**
- T2: 58 N·m (5.9 kgf-m, 42.8 ft-lb)**

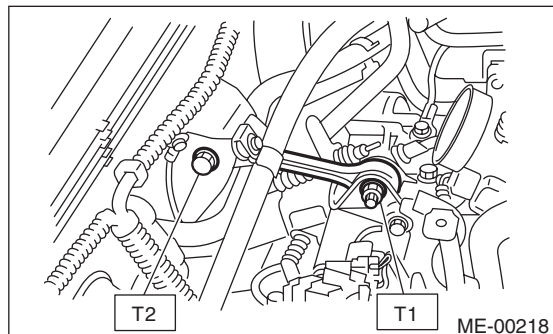

14) Install the radiator upper brackets.

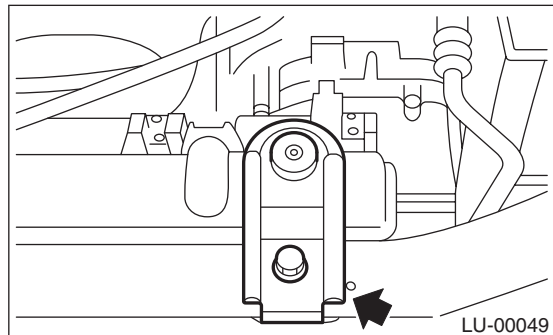

15) Install the air intake chamber.
 <Ref. to IN(H4SO)-6, INSTALLATION, Air Intake Chamber.>

16) Install the air intake duct and air cleaner case.
 <Ref. to IN(H4SO)-7, INSTALLATION, Air Intake Duct.>, <Ref. to IN(H4SO)-5, INSTALLATION, Air Cleaner Case.>

17) Install the front wheels.

Tightening torque:

100 N·m (10.2 kgf-m, 73.8 ft-lb)

Oil Pan and Strainer

LUBRICATION

18) Connect the ground cable to the battery.

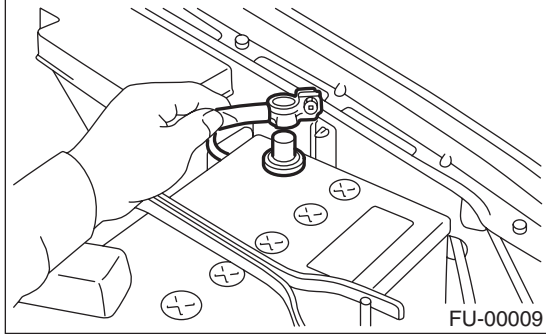

19) Refill the engine oil. <Ref. to LU(H4SO)-8, INSPECTION, Engine Oil.>

C: INSPECTION

Visually check that the oil pan, oil strainer, oil strainer stay and baffle plate are not damaged.

6. Oil Pressure Switch

A: REMOVAL

- 1) Remove the generator from the bracket. <Ref. to SC(H4SO)-14, REMOVAL, Generator.>
- 2) Disconnect the terminal from oil pressure switch.

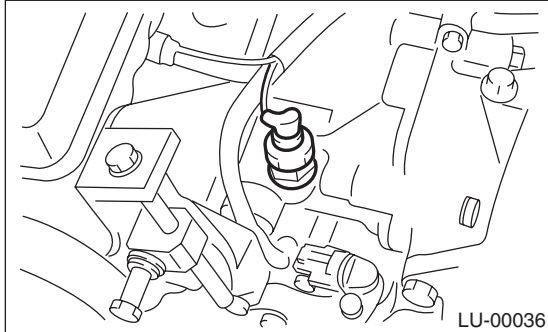

- 3) Remove the oil pressure switch.

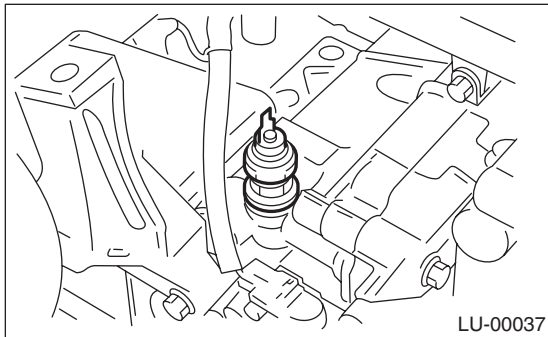

B: INSTALLATION

- 1) Apply liquid gasket to the oil pressure switch threads.

Liquid gasket:

THREE BOND 1324 (Part No. 004403042) or equivalent

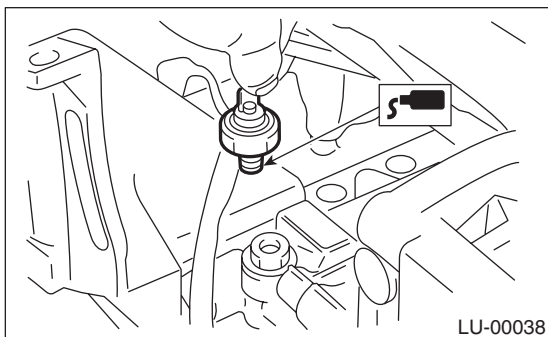

- 2) Install the oil pressure switch to the cylinder block.

Tightening torque:

25 N·m (2.5 kgf-m, 18.1 ft-lb)

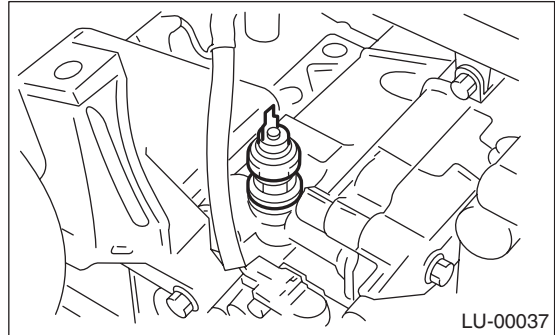

- 3) Connect the terminal to the oil pressure switch.

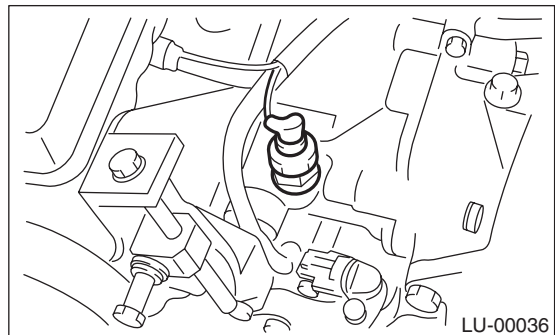

- 4) Install the generator to the bracket. <Ref. to SC(H4SO)-14, INSTALLATION, Generator.>

C: INSPECTION

Check the oil pressure switch installation portion for oil leakage and oil seepage.

7. Engine Oil Filter

A: REMOVAL

- 1) Set the vehicle on a lift.
- 2) Lift up the vehicle.
- 3) Remove the under cover.
- 4) Remove the oil filter using the ST.

NOTE:

The standard oil filter outer diameter is 68 mm (2.68 in), however it is also possible to use a Subaru oil filter with an outer diameter of 65 mm (2.56 in).

- | | |
|---------------|--|
| ST 18332AA000 | OIL FILTER WRENCH (OUTER DIAMETER: 68 mm (2.68 in) FOR OIL FILTER) |
| ST 18332AA010 | OIL FILTER WRENCH (OUTER DIAMETER: 65 mm (2.56 in) FOR OIL FILTER) |

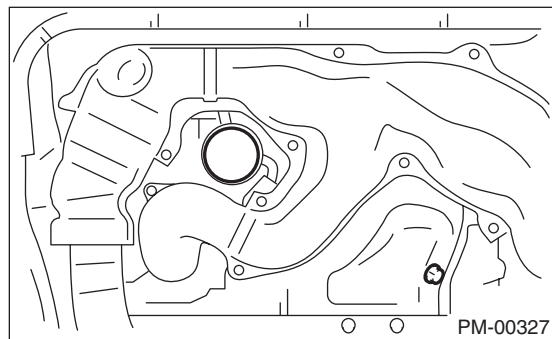

B: INSTALLATION

CAUTION:

Do not overtighten. Doing so may cause an oil leak.

- 1) Clean the oil filter installing surface of cylinder block.
- 2) Obtain a new oil filter and apply a thin coat of engine oil to the seal rubber.
- 3) Install the oil filter turning it by hand, being careful not to damage the seal rubber.
 - Tighten the oil filter with 65 mm (2.56 in) in diameter further (approx. 2/3 — 3/4 rotations) after the seal rubber of the oil filter comes in contact with cylinder block. When using a torque wrench, tighten to 12 N·m (1.2 kgf-m, 8.7 ft-lb).
 - Tighten the oil filter with 68 mm (2.68 in) in diameter further (approx. 1 rotation) after the seal rubber of the oil filter comes in contact with cylinder block. When using a torque wrench, tighten to 14 N·m (1.4 kgf-m, 10.3 ft-lb).
- 4) Lower the vehicle.

C: INSPECTION

- 1) After installing the oil filter, run the engine and make sure that no oil is leaking around seal rubber.

NOTE:

The filter element and filter case are permanently jointed; therefore, interior cleaning is not necessary.

- 2) Check the engine oil level. <Ref. to LU(H4SO)-8, INSPECTION, Engine Oil.>

8. Engine Lubrication System Trouble in General

A: INSPECTION

Before performing diagnostics, make sure that the engine oil level is correct and no oil leakage exists.

Symptoms	Possible cause		Corrective action
1. Warning light remains ON.	1) Oil pressure switch failure	Cracked diaphragm or oil leakage within switch	Replace.
		Broken spring or seized contacts	Replace.
	2) Low oil pressure	Clogging of oil filter	Replace.
		Malfunction of oil by-pass valve in oil filter	Clean or replace.
		Malfunction of oil relief valve in oil pump	Clean or replace.
		Clogged oil passage	Clean.
		Excessive tip clearance and side clearance between oil pump rotor and gear	Replace.
		Clogged oil strainer or broken pipe	Clean or replace.
	3) No oil pressure	Insufficient engine oil (degradation, etc.)	Replace.
		Broken pipe of oil strainer	Replace.
Stuck oil pump rotor		Replace.	
2. Warning light does not illuminate.	1) Malfunction of combination meter		Replace.
	2) Poor contact of switch contact points		Replace.
	3) Disconnection of wiring		Repair.
3. Warning light flickers momentarily.	1) Poor contact of terminals		Repair.
	2) Defective wiring harness		Repair.
	3) Low oil pressure		Check for the same possible causes as listed 1. — 2.

Engine Lubrication System Trouble in General

LUBRICATION

Brought to you by Eris Studios
NOT FOR RESALE