

Brought to you by Eris Studios
NOT FOR RESALE

MECHANICAL

General Description

MECHANICAL

1. General Description

A: SPECIFICATION

Engine	Model		2.5 L		
	Cylinder arrangement		Horizontally opposed, liquid cooled, 4-cylinder, 4-stroke gasoline engine		
	Valve system mechanism		Belt driven Single overhead camshaft 4-valve/cylinder		
	Bore × Stroke		mm (in)		
	Piston displacement		cm ³ (cu in)		
	Compression ratio		10.0		
	Compression pressure (at 350 rpm)		kPa (kgf/cm ² , psi)		
	Number of piston rings		Pressure ring: 2, Oil ring: 1		
	Intake valve timing		Constant	Open	BTDC 0°
				Close	ABDC 58°
			Low speed	Open	BTDC 0°
				Close	ABDC -50°
			High speed	Open	BTDC 14°
				Close	ABDC 62°
	Exhaust valve timing		Open	BBDC 54°	
			Close	ATDC 14°	
	Valve clearance		mm (in)	Intake	0.20±0.04 (0.0079±0.0016)
				Exhaust	0.25±0.04 (0.0098±0.0016)
	Idling speed [at neutral position on MT, or "P" or "N" position on AT]		rpm	MT	650±100 (No load) 850±100 (A/C ON)
				AT	700±100 (No load) 850±100 (A/C ON)
Ignition order			1 → 3 → 2 → 4		
Ignition timing		BTDC/rpm	MT	10°±8°/650	
			AT	15°±8°/700	

NOTE:

US: Undersize OS: Oversize

General Description

MECHANICAL

Belt tension adjuster	Protrusion of adjuster rod		mm (in)	5.2 — 6.2 (0.205 — 0.244)		
Belt tensioner	Spacer O.D.		mm (in)	17.955 — 17.975 (0.7069 — 0.7077)		
	Tensioner bushing I.D.		mm (in)	18.00 — 18.08 (0.7087 — 0.7118)		
	Clearance between spacer and bushing	mm (in)	Standard	0.025 — 0.125 (0.0010 — 0.0049)		
			Limit	0.175 (0.069)		
	Side clearance of spacer	mm (in)	Standard	0.20 — 0.55 (0.0079 — 0.0217)		
Limit			0.81 (0.0319)			
Valve rocker arm	Clearance between shaft and arm	mm (in)	Standard	0.020 — 0.054 (0.0008 — 0.0021)		
			Limit	0.10 (0.0039)		
Camshaft	Bending limit		mm (in)	0.025 (0.0010)		
	Thrust clearance	mm (in)	Standard	0.030 — 0.090 (0.0012 — 0.0035)		
			Limit	0.10 (0.0039)		
	Cam lobe height	mm (in)	Intake	Constant	Standard 40.075 — 40.175 (1.5778 — 1.5817)	
				Low speed	Standard	35.182 — 35.282 (1.3851 — 1.3891)
					Limit	35.082 (1.3812)
			Exhaust	High speed	Standard	40.315 — 40.415 (1.5872 — 1.5911)
				Limit	Standard	40.149 — 40.249 (1.5807 — 1.5846)
					Limit	40.049 (1.5767)
	Camshaft journal O.D.		mm (in)	31.928 — 31.945 (1.2570 — 1.2577)		
	Camshaft journal hole I.D.		mm (in)	32.000 — 32.018 (1.2598 — 1.2605)		
	Oil clearance	mm (in)	Standard	0.055 — 0.090 (0.0022 — 0.0035)		
			Limit	0.10 (0.0039)		
Cylinder head	Surface warpage limit (Mating surface with cylinder block)		mm (in)	0.035 (0.0014)		
	Grinding limit		mm (in)	0.1 (0.004)		
	Standard height		mm (in)	97.5 (3.84)		
Valve seat	Seating angle			90°		
	Contacting width	mm (in)	Intake	Standard	0.8 — 1.4 (0.03 — 0.055)	
				Limit	1.7 (0.067)	
			Exhaust	Standard	1.2 — 1.8 (0.047 — 0.071)	
Limit				2.2 (0.087)		
Valve guide	Inside diameter		mm (in)	6.000 — 6.012 (0.2362 — 0.2367)		
	Protrusion above head	mm (in)	Intake	Standard	20.0 — 21.0 (0.787 — 0.827)	
				Exhaust	16.5 — 17.5 (0.650 — 0.689)	
			Exhaust	Standard	0.8 — 1.2 (0.03 — 0.047)	
Limit				0.6 (0.024)		
Valve	Head edge thickness	mm (in)	Intake	Standard	0.8 — 1.2 (0.03 — 0.047)	
				Limit	0.6 (0.024)	
			Exhaust	Standard	1.0 — 1.4 (0.039 — 0.055)	
				Limit	0.6 (0.024)	
	Stem outer diameter	mm (in)	Intake	5.950 — 5.965 (0.2343 — 0.2348)		
			Exhaust	5.945 — 5.960 (0.2341 — 0.2346)		
	Valve stem gap	mm (in)	Standard	Intake	0.035 — 0.062 (0.0014 — 0.0024)	
				Exhaust	0.040 — 0.067 (0.0016 — 0.0026)	
Overall length	mm (in)		Limit	— 0.15 (0.059)		
			Intake	120.6 (4.75)		
			Exhaust	121.7 (4.79)		

General Description

MECHANICAL

Valve spring	Free length		mm (in)	55.2 (2.173)		
	Squareness			2.5°, 2.4 mm (0.094 in) or less		
	Tension/spring height	N (kgf, lbf)/mm (in)	Set	235.3 — 270.7 (24 — 27.6, 52.9 — 60.8) / 45.0 (1.772)		
			Lift	578.9 — 639.9 (59.1 — 65.3, 130.3 — 143.9) / 34.7 (1.366)		
Cylinder block	Surface warpage limit (mating with cylinder head)		mm (in)	0.025 (0.00098)		
	Grinding limit		mm (in)	0.1 (0.004)		
	Standard height		mm (in)	201.0 (7.91)		
	Cylinder inner diameter	mm (in)	Standard	A	99.505 — 99.515 (3.9175 — 3.9179)	
				B	99.495 — 99.505 (3.9171 — 3.9175)	
	Taper	mm (in)		Standard	0.015 (0.0006)	
				Limit	0.050 (0.0020)	
	Out-of-roundness	mm (in)		Standard	0.010 (0.0004)	
				Limit	0.050 (0.0020)	
	Piston clearance	mm (in)		Standard	-0.010 — 0.010 (-0.00039 — 0.00039)	
Limit				0.030 (0.0012)		
Cylinder inner diameter boring limit (diameter)		mm (in)	To 100.005 (3.9372)			
Piston	Outer diameter	mm (in)	Standard	A	99.505 — 99.515 (3.9175 — 3.9179)	
				B	99.495 — 99.505 (3.9171 — 3.9175)	
			0.25 (0.0098) OS			99.745 — 99.765 (3.9270 — 3.9278)
			0.50 (0.0197) OS			99.995 — 100.015 (3.9368 — 3.9376)
Piston pin specified diameter		mm (in)	23.000 — 23.006 (0.9055 — 0.9057)			
Piston pin	Outer diameter		mm (in)	22.994 — 23.000 (0.9053 — 0.9055)		
	Clearance between piston and piston pin:	mm (in)	Standard	0.004 — 0.008 (0.0002 — 0.0003)		
			Limit	0.020 (0.0008)		
Degree of fit			Piston pin must be fitted into position with thumb at 20°C (68°F).			
Piston ring	Ring closed gap	mm (in)	Top ring	Standard	0.20 — 0.35 (0.0079 — 0.0138)	
				Limit	1.0 (0.039)	
		Second ring	Standard	0.37 — 0.52 (0.0144 — 0.0203)		
			Limit	1.0 (0.039)		
	Oil ring	mm (in)	Standard	0.20 — 0.50 (0.0079 — 0.0197)		
			Limit	1.5 (0.059)		
	Ring groove gap	mm (in)	Top ring	Standard	0.040 — 0.080 (0.0016 — 0.0031)	
				Limit	0.15 (0.0059)	
Second ring		Standard	0.030 — 0.070 (0.0012 — 0.0028)			
		Limit	0.15 (0.0059)			
Connecting rod	Bend or twist per 100 mm (3.94 in) in length		mm (in)	Limit	0.10 (0.0039)	
	Thrust clearance	mm (in)	Standard	0.070 — 0.330 (0.0028 — 0.0130)		
			Limit	0.4 (0.016)		
Bearing of large end	Oil clearance	mm (in)	Standard	0.016 — 0.044 (0.00063 — 0.0017)		
			Limit	0.05 (0.0020)		
	Bearing size (Thickness at center)	mm (in)	Standard	1.492 — 1.501 (0.0587 — 0.0591)		
			0.03 (0.0012) US	1.510 — 1.513 (0.0594 — 0.0596)		
			0.05 (0.0020) US	1.520 — 1.523 (0.0598 — 0.0600)		
	0.25 (0.0098) US	1.620 — 1.623 (0.0638 — 0.0639)				
Bushing of small end	Clearance between piston pin and bushing		mm (in)	Standard	0 — 0.022 (0 — 0.0009)	
				Limit	0.030 (0.0012)	

General Description

MECHANICAL

Crankshaft	Bend limit		mm (in)	0.035 (0.0014)	
	Crank pin	Out-of-roundness		mm (in)	0.003 (0.0001)
		Cylindricality		mm (in)	0.004 (0.0002)
		Grinding limit (dia.)		mm (in)	To 51.750 (2.0374)
	Crank journal	Out-of-roundness		mm (in)	0.005 (0.0002)
		Cylindricality		mm (in)	0.006 (0.0002)
		Grinding limit (dia.)		mm (in)	To 59.758 (2.3527)
	Crank pin outer diameter	mm (in)	Standard		51.984 — 52.000 (2.0466 — 2.0472)
			0.03 (0.0012) US		51.954 — 51.970 (2.0454 — 2.0461)
			0.05 (0.0020) US		51.934 — 51.950 (2.0446 — 2.0453)
			0.25 (0.0098) US		51.734 — 51.750 (2.0368 — 2.0374)
	Crank journal outer diameter	mm (in)	Standard		59.992 — 60.008 (2.3619 — 2.3625)
			0.03 (0.0012) US		59.962 — 59.978 (2.3607 — 2.3613)
			0.05 (0.0020) US		59.942 — 59.958 (2.3599 — 2.3605)
			0.25 (0.0098) US		59.742 — 59.758 (2.3520 — 2.3527)
	Thrust clearance	mm (in)	Standard		0.030 — 0.115 (0.0012 — 0.0045)
Limit			0.25 (0.0098)		
Oil clearance	mm (in)	Standard		0.010 — 0.030 (0.0004 — 0.0012)	
		Limit		0.40 (0.0016)	
Main bearing	Main bearing mm (in)	#1, #3	Standard		1.998 — 2.011 (0.0787 — 0.0792)
			0.03 (0.0012) US		2.017 — 2.020 (0.0794 — 0.0795)
			0.05 (0.0020) US		2.027 — 2.030 (0.0798 — 0.0799)
			0.25 (0.0098) US		2.127 — 2.130 (0.0837 — 0.0839)
	#2, #4, #5	Standard		2.000 — 2.013 (0.0787 — 0.0793)	
		0.03 (0.0012) US		2.019 — 2.022 (0.0795 — 0.0796)	
		0.05 (0.0020) US		2.029 — 2.032 (0.0799 — 0.0800)	
		0.25 (0.0098) US		2.129 — 2.132 (0.0838 — 0.0839)	

General Description

MECHANICAL

B: COMPONENT

1. TIMING BELT

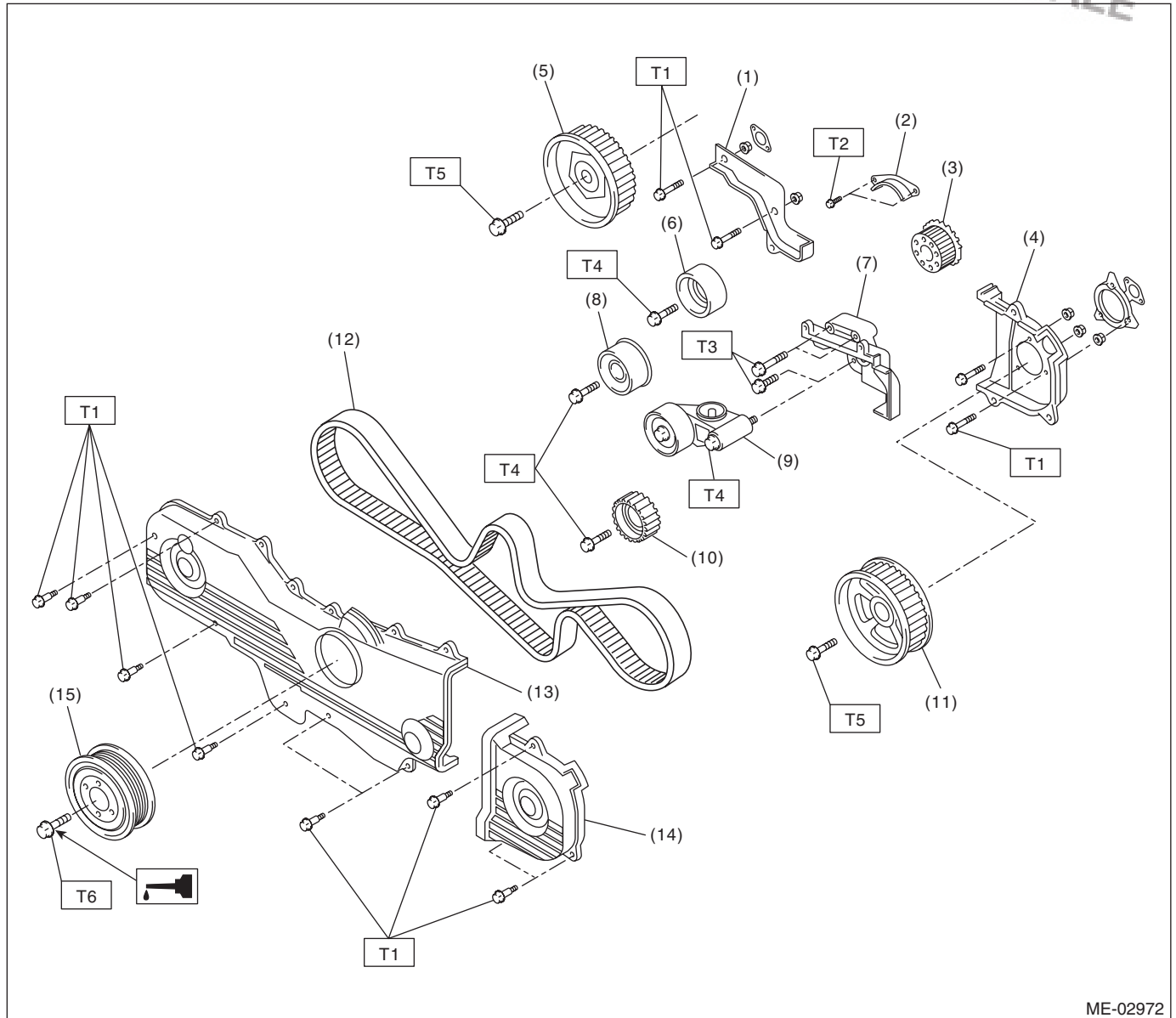

ME-02972

- | | |
|----------------------------------|------------------------------------------|
| (1) Timing belt cover No. 2 (RH) | (9) Automatic belt tension adjuster ASSY |
| (2) Timing belt guide (MT model) | (10) Belt idler No. 2 |
| (3) Crank sprocket | (11) Cam sprocket No. 2 |
| (4) Timing belt cover No. 2 (LH) | (12) Timing belt |
| (5) Cam sprocket No. 1 | (13) Front timing belt cover |
| (6) Belt idler (No. 1) | (14) Timing belt cover (LH) |
| (7) Tensioner bracket | (15) Crank pulley |
| (8) Belt idler (No. 2) | |

Tightening torque: N·m (kgf·m, ft·lb)

- T1: 5 (0.5, 3.6)**
T2: 9.75 (1.0, 7.2)
T3: 24.5 (2.5, 18.1)
T4: 39 (4.0, 28.9)
T5: 78 (8.0, 57.9)
T6: <Ref. to ME(H4SO)-41, INSTALLATION, Crank Pulley.>

2. CYLINDER HEAD AND CAMSHAFT

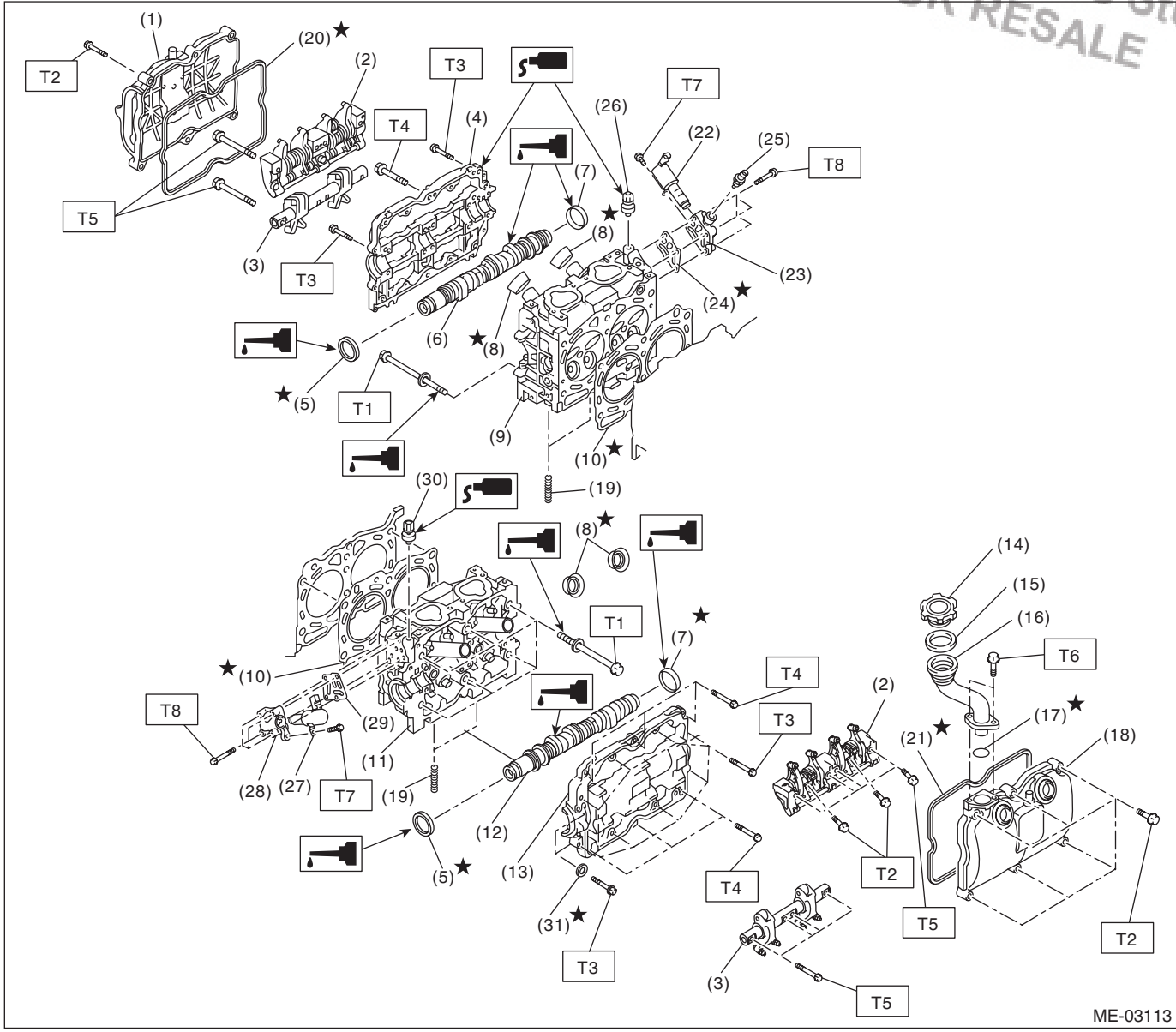

ME-03113

General Description

MECHANICAL

(1) Rocker cover (RH) (2) Intake valve rocker ASSY (3) Exhaust valve rocker ASSY (4) Camshaft cap (RH) (5) Oil seal (6) Camshaft (RH) (7) Plug (8) Spark plug pipe gasket (9) Cylinder head (RH) (10) Cylinder head gasket (11) Cylinder head (LH) (12) Camshaft (LH) (13) Camshaft cap (LH) (14) Oil filler cap (15) Gasket (16) Oil filler duct	(17) O-ring (18) Rocker cover (LH) (19) Stud bolt (20) Rocker cover gasket (RH) (21) Rocker cover gasket (LH) (22) Oil switching solenoid valve (RH) (23) Oil switching solenoid valve holder (RH) (24) Gasket (25) Oil temperature sensor (26) Variable valve lift diagnosis oil pressure switch (RH) (27) Oil switching solenoid valve (LH) (28) Oil switching solenoid valve holder (LH) (29) Gasket	(30) Variable valve lift diagnosis oil pressure switch (LH) (31) Seal washer
------------------------------------------------------------------------------------------------------------------------------------------------------------------------------------------------------------------------------------------------------------------------------------------------------------------------------------------------------------------------------------------------	---------------------------------------------------------------------------------------------------------------------------------------------------------------------------------------------------------------------------------------------------------------------------------------------------------------------------------------------------------------------------------------------------------------------------------------------	---------------------------------------------------------------------------------

Tightening torque: N·m (kgf·m, ft·lb)

T1: <Ref. to ME(H4SO)-58, INSTALLATION, Cylinder Head.>

T2: <Ref. to ME(H4SO)-51, INSTALLATION, Valve Rocker Assembly.>

T3: 9.75 (1.0, 7.2)

T4: 18 (1.8, 13.0)

T5: 25 (2.5, 18.1)

T6: 6.4 (0.65, 4.7)

T7: 8 (0.8, 5.9)

T8: 10 (1.0, 7.4)

3. VALVE ROCKER ASSEMBLY

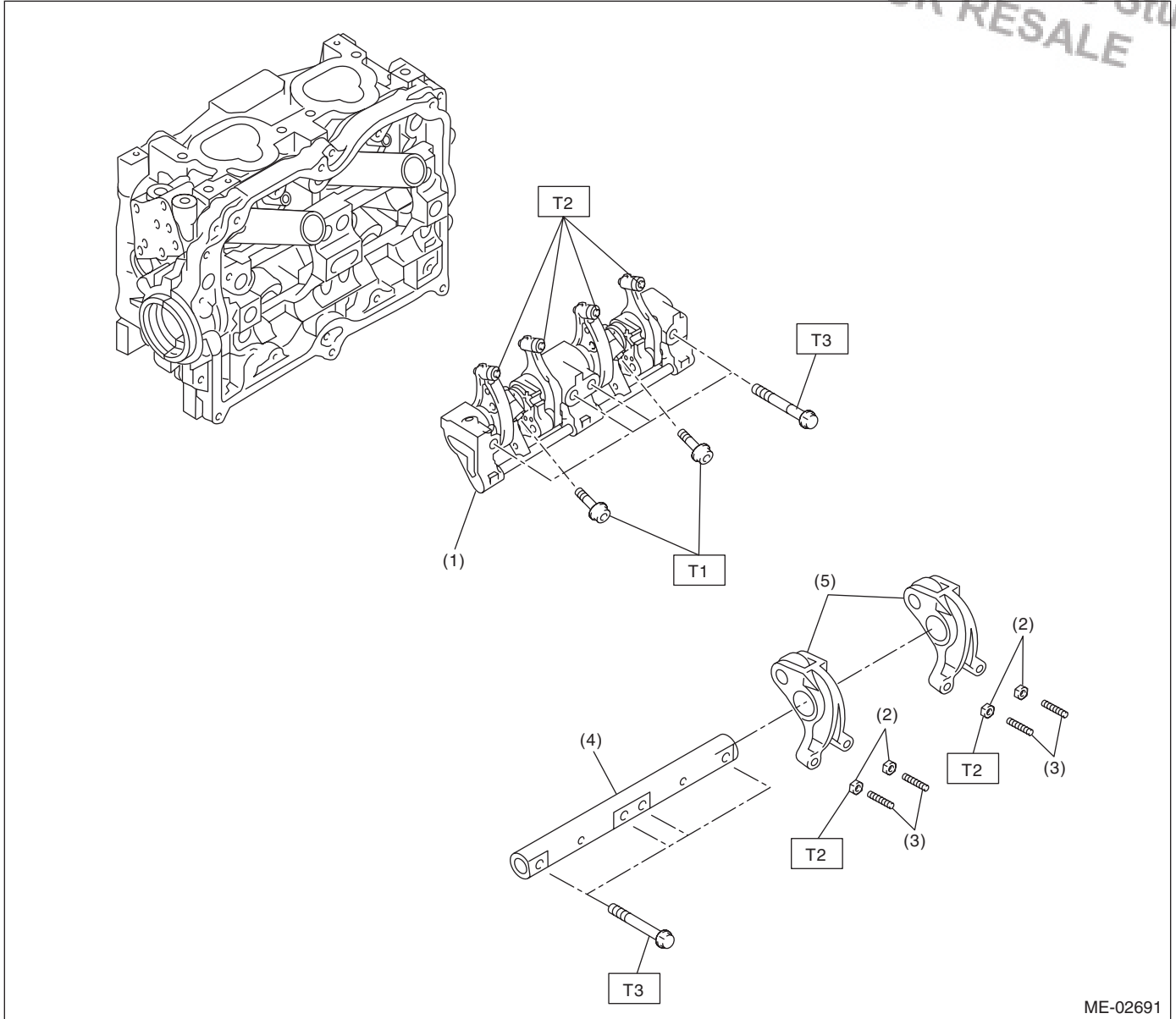

ME-02691

- | | |
|----------------------------------|------------------------------|
| (1) Intake valve rocker arm ASSY | (4) Exhaust rocker shaft |
| (2) Valve rocker nut | (5) Exhaust valve rocker arm |
| (3) Valve rocker adjuster screw | |

Tightening torque: N·m (kgf·m, ft·lb)

T1: 6 (0.6, 4.3)

T2: 9.75 (1.0, 7.2)

T3: 25 (2.5, 18.4)

General Description

MECHANICAL

4. CYLINDER HEAD AND VALVE ASSEMBLY

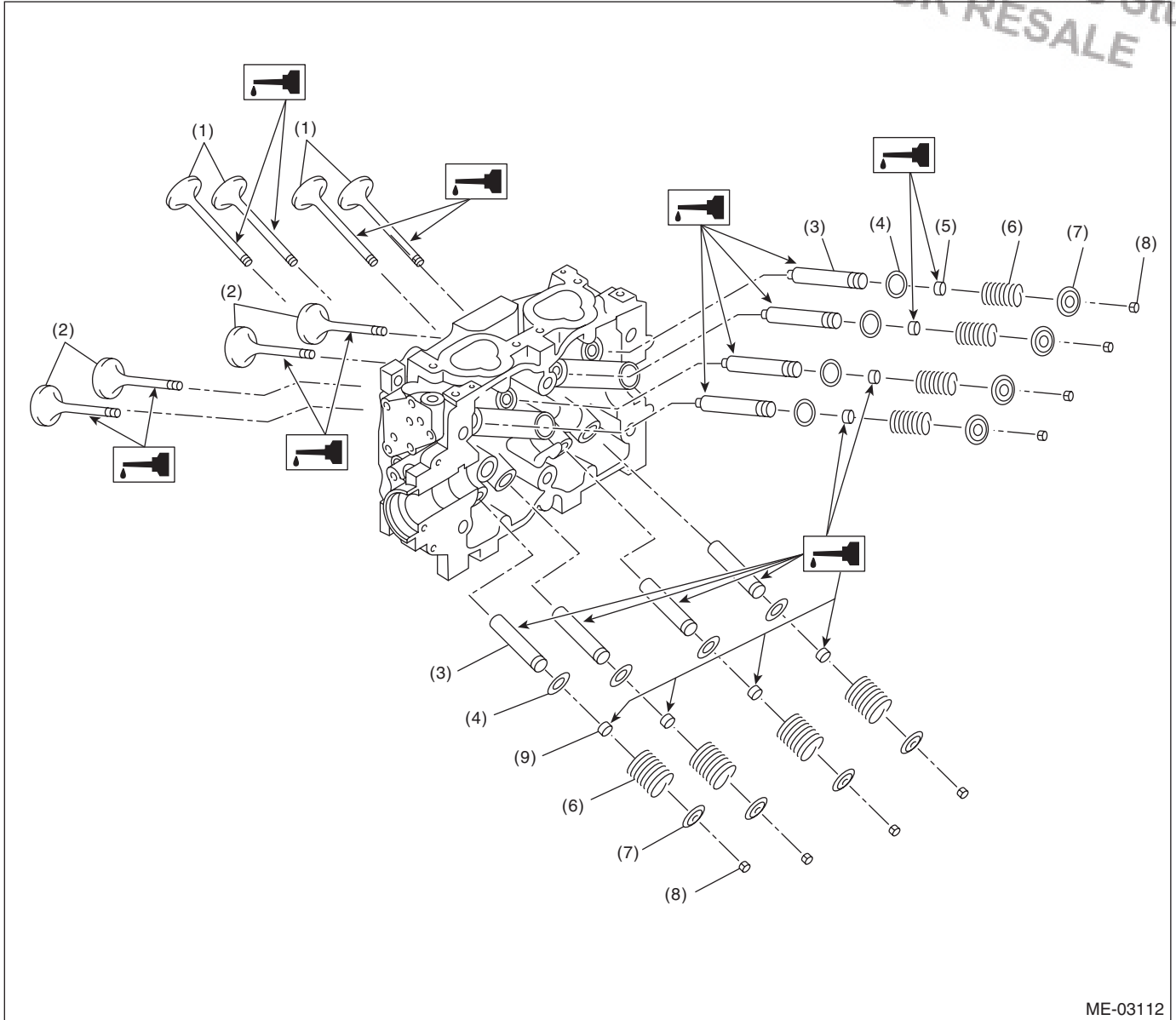

- (1) Exhaust valve
- (2) Intake valve
- (3) Valve guide

- (4) Valve spring seat
- (5) Intake valve oil seal
- (6) Valve spring

- (7) Retainer
- (8) Retainer key
- (9) Exhaust valve oil seal

5. CYLINDER BLOCK

Brought to you by Eris Studios
NOT FOR RESALE

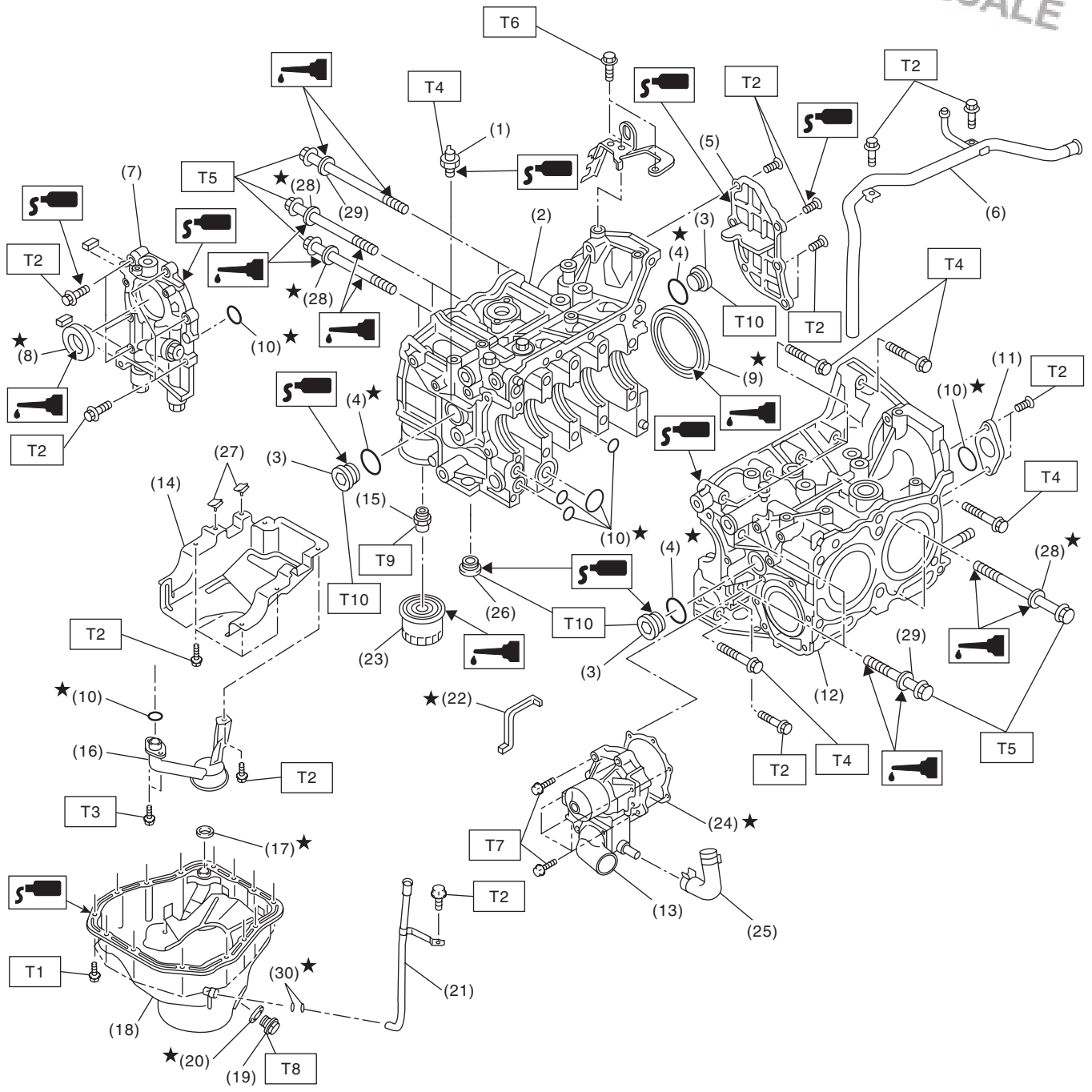

ME-03180

General Description

MECHANICAL

- | | |
|---------------------------|----------------------------|
| (1) Oil pressure switch | (16) Oil strainer |
| (2) Cylinder block (RH) | (17) Gasket |
| (3) Service hole plug | (18) Oil pan |
| (4) Gasket | (19) Drain plug |
| (5) Oil separator cover | (20) Metal gasket |
| (6) Water by-pass pipe | (21) Oil level gauge guide |
| (7) Oil pump | (22) Water pump sealing |
| (8) Front oil seal | (23) Oil filter |
| (9) Rear oil seal | (24) Gasket |
| (10) O-ring | (25) Water pump hose |
| (11) Service hole cover | (26) Plug |
| (12) Cylinder block (LH) | (27) Seal |
| (13) Water pump | (28) Seal washer |
| (14) Baffle plate | (29) Washer |
| (15) Oil filter connector | (30) O-ring |

Tightening torque: N·m (kgf-m, ft-lb)

T1: 5 (0.5, 3.7)

T2: 6.4 (0.65, 4.7)

T3: 10 (1.0, 7.4)

T4: 25 (2.5, 18.4)

T5: <Ref. to ME(H4SO)-71, INSTALLATION, Cylinder Block.>

T6: 16 (1.6, 11.8)

T7: First 12 (1.2, 8.7)

Second 12 (1.2, 8.7)

T8: 44 (4.5, 33)

T9: 45 (4.6, 33.3)

T10: 70 (7.1, 51.6)

6. CRANKSHAFT AND PISTON

Brought to you by Eris Studios
NOT FOR RESALE

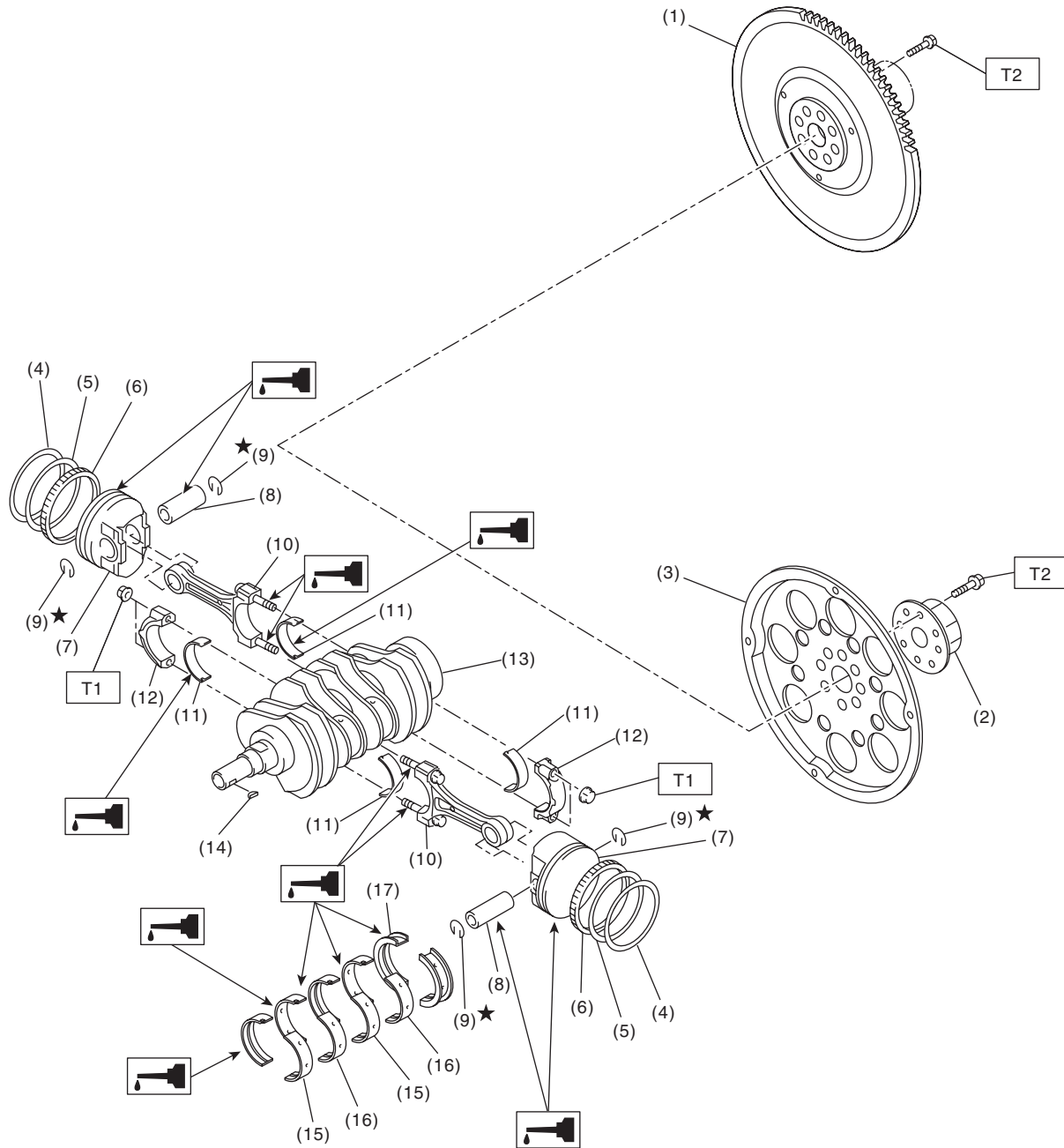

ME-03219

- | | | |
|------------------------------|-----------------------------|--------------------------------|
| (1) Flywheel (MT model) | (8) Piston pin | (15) Crankshaft bearing #1, #3 |
| (2) Reinforcement (AT model) | (9) Snap ring | (16) Crankshaft bearing #2, #4 |
| (3) Drive plate (AT model) | (10) Connecting rod | (17) Crankshaft bearing #5 |
| (4) Top ring | (11) Connecting rod bearing | |
| (5) Second ring | (12) Connecting rod cap | |
| (6) Oil ring | (13) Crankshaft | |
| (7) Piston | (14) Woodruff key | |

Tightening torque: N·m (kgf·m, ft·lb)

T1: 45 (4.6, 33.2)

T2: 72 (7.3, 52.8)

7. ENGINE MOUNTING

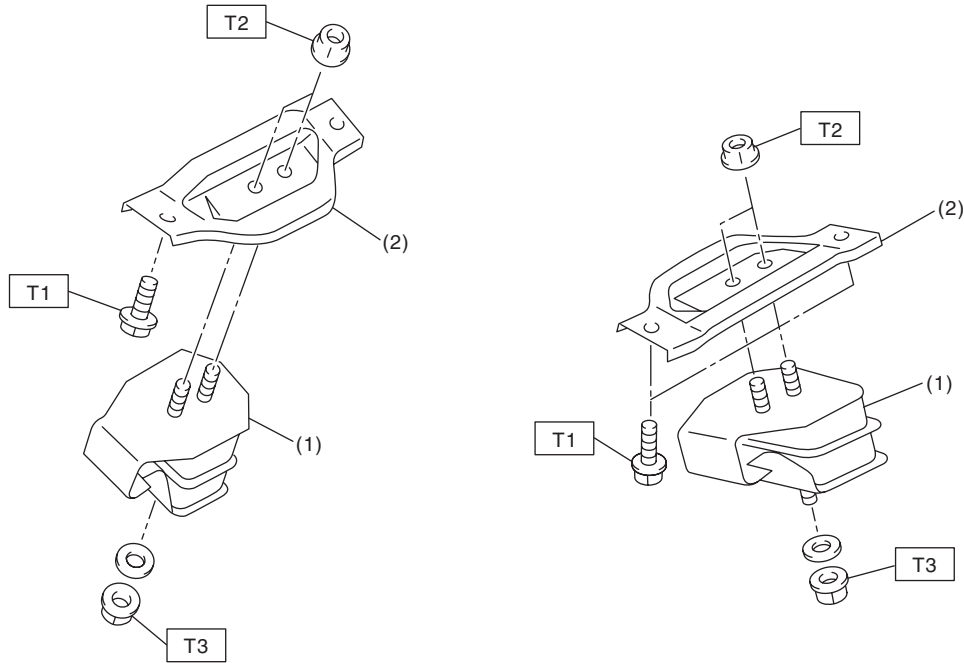

ME-00413

(1) Front cushion rubber

(2) Front engine mounting bracket

Tightening torque:N·m (kgf·m, ft·lb)

T1: 35 (3.6, 25.8)

T2: 42 (4.3, 31.0)

T3: 85 (8.7, 63)

C: CAUTION

- Wear appropriate work clothing, including a cap, protective goggles and protective shoes when performing any work.
- Remove contamination including dirt and corrosion before removal, installation or disassembly.
- Keep the disassembled parts in order and protect them from dust and dirt.
- Before removal, installation or disassembly, be sure to clarify the failure. Avoid unnecessary removal, installation, disassembly and replacement.
- Vehicle components are extremely hot after driving. Be wary of receiving burns from heated parts.
- Be sure to tighten fasteners including bolts and nuts to the specified torque.
- Place shop jacks or rigid racks at the specified points.
- Before disconnecting connectors of sensors or units, be sure to disconnect the ground cable from the battery.
- All parts should be thoroughly cleaned, paying special attention to engine oil passages, pistons and bearings.
- Rotating parts and sliding parts such as piston, bearing and gear should be coated with oil prior to assembly.
- Be careful not to let oil, grease or coolant contact the timing belt, clutch disc and flywheel.
- All removed parts, if to be reused, should be reinstalled in the original positions and directions.
- Bolts, nuts and washers should be replaced with new parts as required.
- Even if necessary inspections have been made in advance, proceed with assembly work while making rechecks.
- Remove or install the engine in an area where chain hoists, lifting devices, etc. are available for ready use.
- Be sure not to damage coated surfaces of body panels with tools, or not to stain seats and windows with coolant or oil. Place a cover over fender, as required, for protection.
- Prior to starting work, prepare the following:
Service tools, clean cloth, containers to catch coolant and oil, wire ropes, chain hoist, transmission jacks, etc.
- Lift-up or lower the vehicle when necessary. Make sure to support the correct positions.

General Description

MECHANICAL

D: PREPARATION TOOL

1. SPECIAL TOOL

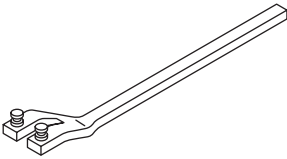
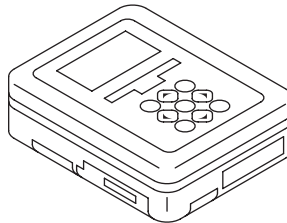
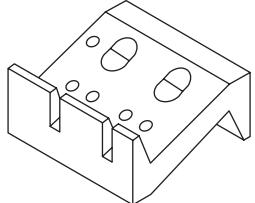
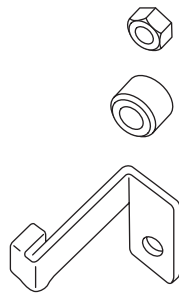
ILLUSTRATION	TOOL NUMBER	DESCRIPTION	REMARKS
 <p style="text-align: center;">ST18231AA010</p>	18231AA010	CAM SPROCKET WRENCH	<ul style="list-style-type: none"> Used for removing and installing cam sprocket. (LH side) CAM SPROCKET WRENCH (499207100) can also be used.
 <p style="text-align: center;">ST1B020XU0</p>	1B020XU0	SUBARU SELECT MONITOR KIT	Used for troubleshooting the electrical system.
 <p style="text-align: center;">ST-498267800</p>	498267800	CYLINDER HEAD TABLE	<ul style="list-style-type: none"> Used for replacing valve guides. Used for removing and installing valve spring.
 <p style="text-align: center;">ST-498277200</p>	498277200	STOPPER SET	Used for installing automatic transmission assembly to engine.

General Description

MECHANICAL

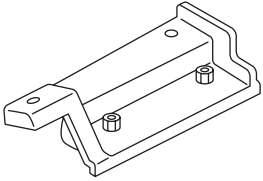
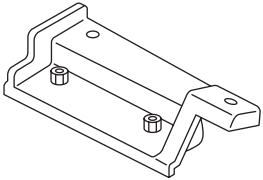
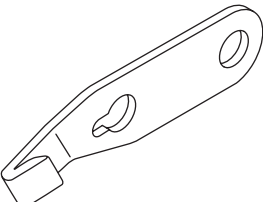
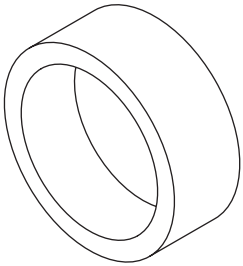
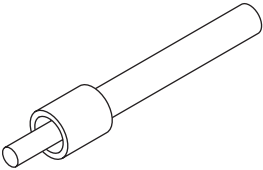
ILLUSTRATION	TOOL NUMBER	DESCRIPTION	REMARKS
 <p>ST-498457000</p>	498457000	ENGINE STAND ADAPTER RH	Used together with the ENGINE STAND (499817100).
 <p>ST-498457100</p>	498457100	ENGINE STAND ADAPTER LH	Used together with the ENGINE STAND (499817100).
 <p>ST-498497100</p>	498497100	CRANKSHAFT STOPPER	Used for removing and installing the flywheel and drive plate.
 <p>ST-498747300</p>	498747300	PISTON GUIDE	Used for installing piston to cylinder.
 <p>ST-498857100</p>	498857100	VALVE OIL SEAL GUIDE	Used for press-fitting of intake and exhaust valve guide oil seals.

General Description

MECHANICAL

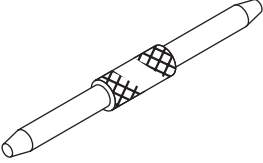
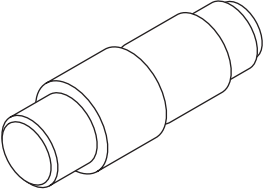
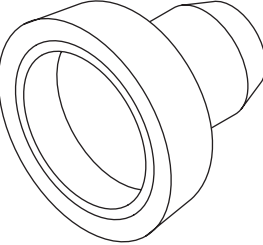
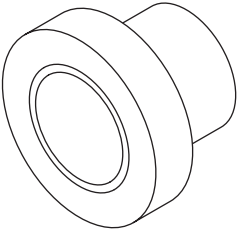
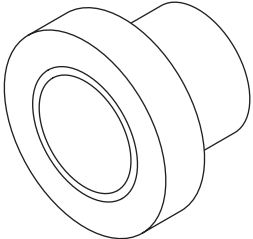
ILLUSTRATION	TOOL NUMBER	DESCRIPTION	REMARKS
 <p style="text-align: center;">ST-499017100</p>	499017100	PISTON PIN GUIDE	Used for installing piston pin, piston and connecting rod.
 <p style="text-align: center;">ST-499037100</p>	499037100	CONNECTING ROD BUSHING REMOVER AND INSTALLER	Used for removing and installing connecting rod bushing.
 <p style="text-align: center;">ST-499587200</p>	499587200	CRANKSHAFT OIL SEAL INSTALLER	<ul style="list-style-type: none"> • Used for installing crankshaft oil seal. • Used together with the CRANK SHAFT OIL SEAL GUIDE (499597100).
 <p style="text-align: center;">ST-499587500</p>	499587500	OIL SEAL INSTALLER	<ul style="list-style-type: none"> • Used for installing the camshaft oil seal. • Used together with the CRANK SHAFT OIL SEAL GUIDE (499597000).
 <p style="text-align: center;">ST-499587700</p>	499587700	CAMSHAFT OIL SEAL INSTALLER	Used for installing cylinder head plug.

General Description

MECHANICAL

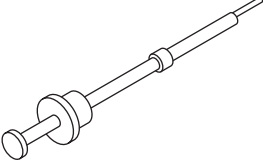
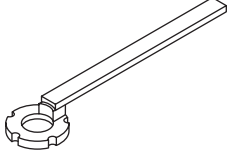
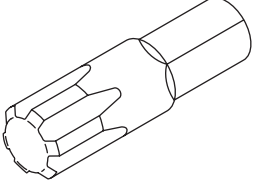
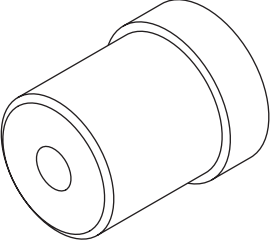
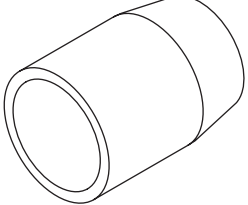
ILLUSTRATION	TOOL NUMBER	DESCRIPTION	REMARKS
 <p data-bbox="337 520 467 541">ST-499097700</p>	499097700	PISTON PIN REMOVER ASSY	Used for removing piston pin.
 <p data-bbox="337 873 467 894">ST-499207400</p>	499207400	CAM SPROCKET WRENCH	Used for removing and installing cam sprocket. (RH side)
 <p data-bbox="337 1226 467 1247">ST-499497000</p>	499497000	TORX PLUS®	Used for removing and installing camshaft cap.
 <p data-bbox="337 1579 467 1600">ST-499587100</p>	499587100	OIL SEAL INSTALLER	Used for installing oil pump oil seal.
 <p data-bbox="337 1923 467 1944">ST-499597000</p>	499597000	OIL SEAL GUIDE	<ul style="list-style-type: none"> • Used for installing the camshaft oil seal. • Used together with the CAMSHAFT OIL SEAL INSTALLER (499587500).

General Description

MECHANICAL

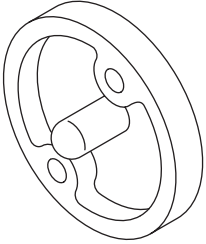
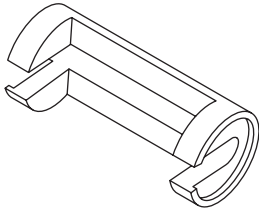
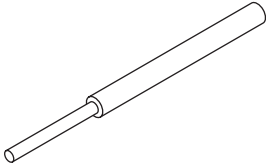
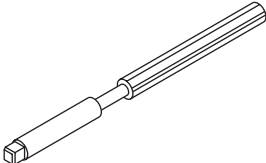
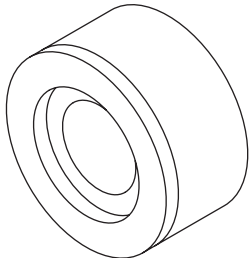
ILLUSTRATION	TOOL NUMBER	DESCRIPTION	REMARKS
 <p style="text-align: center;">ST-499597100</p>	499597100	CRANKSHAFT OIL SEAL GUIDE	<ul style="list-style-type: none"> • Used for installing crankshaft oil seal. • Used together with the CRANKSHAFT OIL SEAL INSTALLER (499587200).
 <p style="text-align: center;">ST-499718000</p>	499718000	VALVE SPRING REMOVER	Used for removing and installing valve spring.
 <p style="text-align: center;">ST-499767200</p>	499767200	VALVE GUIDE REMOVER	Used for removing valve guides.
 <p style="text-align: center;">ST-499767400</p>	499767400	VALVE GUIDE REAMER	Used for reaming valve guides.
 <p style="text-align: center;">ST-499767700</p>	499767700	VALVE GUIDE ADJUSTER	Used for installing valve guides. (Intake side)

General Description

MECHANICAL

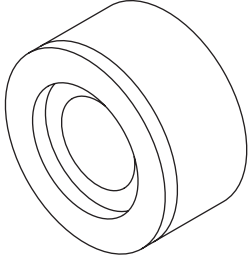
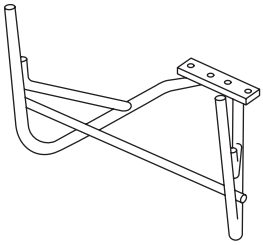
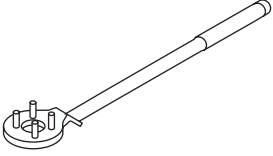
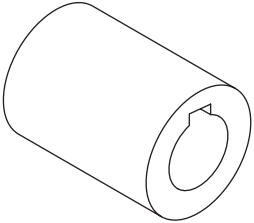
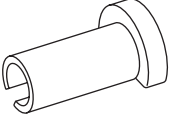
ILLUSTRATION	TOOL NUMBER	DESCRIPTION	REMARKS
 <p data-bbox="337 520 467 541">ST-499767800</p>	499767800	VALVE GUIDE ADJUSTER	Used for installing valve guides. (Exhaust side)
 <p data-bbox="337 871 467 892">ST-499817100</p>	499817100	ENGINE STAND	<ul style="list-style-type: none"> • Stand used for engine disassembly and assembly. • Used together with the ENGINE STAND ADAPTER RH (498457000) & LH (498457100).
 <p data-bbox="337 1224 467 1245">ST-499977100</p>	499977100	CRANK PULLEY WRENCH	Used for stopping rotation of crank pulley when loosening/tightening crank pulley bolt.
 <p data-bbox="337 1577 467 1598">ST-499987500</p>	499987500	CRANKSHAFT SOCKET	Used for rotating crankshaft.
 <p data-bbox="321 1927 474 1948">ST42099AE000</p>	42099AE000	CONNECTOR REMOVER	Used for removing the quick connector.

General Description

MECHANICAL

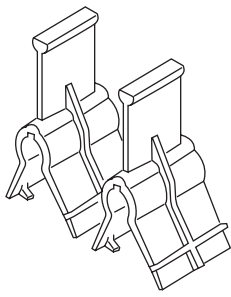
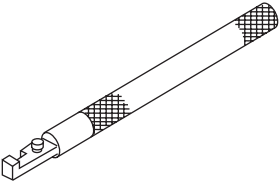
ILLUSTRATION	TOOL NUMBER	DESCRIPTION	REMARKS
 <p style="text-align: center;">ST18354AA000</p>	18354AA000	VALVE ROCKER HOLDER	Used for installing the valve rocker assembly (intake). (2-piece set)
 <p style="text-align: center;">ST18258AA000</p>	18258AA000	SPRING INSTALLER	Used for installing the valve rocker assembly (intake).

2. GENERAL TOOL

TOOL NAME	REMARKS
Compression gauge	Used for measuring compression.
Vacuum gauge	Used for vacuum measurement of the intake manifold.
Oil pressure gauge	Used for measuring engine oil pressure.
Fuel pressure gauge	Used for measuring fuel pressure.
Timing light	Used for measuring ignition timing.

E: PROCEDURE

It is possible to conduct the following service procedures with engine on vehicle, however, the procedures described in this section are based on the condition that the engine is removed from vehicle.

- V-belt
- Timing belt
- Valve rocker ASSY
- Camshaft
- Cylinder head

2. Compression

A: INSPECTION

CAUTION:

After warming-up, engine becomes very hot. Be careful not to burn yourself during measurement.

- 1) After warming-up the engine, turn the ignition switch to OFF.
- 2) Make sure that the battery is fully charged.
- 3) Release the fuel pressure.
<Ref. to FU(H4SO)-43, RELEASING OF FUEL PRESSURE, PROCEDURE, Fuel.>
- 4) Remove all spark plugs. <Ref. to IG(H4SO)-4, REMOVAL, Spark Plug.>
- 5) Fully open the throttle valve.
- 6) Check the starter motor for satisfactory performance and operation.
- 7) Hold the compression gauge tightly against the spark plug hole.

NOTE:

When using a screw-in type compression gauge, the screw (put into cylinder head spark plug hole) should be less than 18 mm (0.71 in) long.

- 8) Crank the engine by the starter motor, and read the maximum value on the gauge when the needle of gauge is steady.

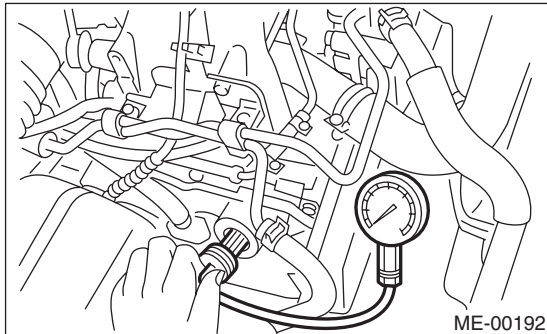

- 9) Perform at least two measurements per cylinder, and make sure that the values are correct.

Compression (350 rpm and fully open throttle):

Standard:

**1,020 — 1,275 kPa (10.4 — 13.0 kgf/cm²,
148 — 185 psi)**

Difference between cylinders:

49 kPa (0.5 kgf/cm², 7 psi), or less

3. Idle Speed

A: INSPECTION

1) Before checking the idle speed, check the following item:

(1) Check the air cleaner element is free from clogging, ignition timing is correct, spark plugs are in good condition, and hoses are connected properly.

(2) Check the malfunction indicator light does not illuminate.

2) Warm-up the engine.

3) Stop the engine, and turn the ignition switch to OFF.

4) Connect the Subaru Select Monitor to the data link connector.

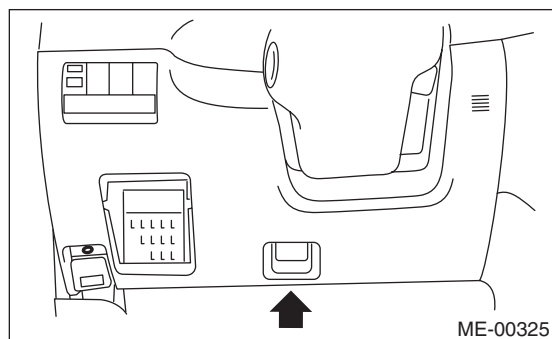

5) Turn the ignition switch to ON and run the Subaru Select Monitor.

6) Select {Each System Check} in Main Menu.

7) Select {Engine Control System} in Selection Menu.

8) Select {Current Data Display & Save} in Engine Control System Diagnosis.

9) Select {Data Display} in Data Display Menu.

10) Start the engine, and read the engine idle speed.

11) Check the idle speed when no-loaded. (Headlight, heater fan, rear defroster, radiator fan, A/C and etc. are OFF)

Idle speed [No load and gears in "N" or "P" range]:

MT model

650±100 rpm

AT model

700±100 rpm

12) Check the idle speed when loaded. (Turn the A/C switch to "ON" and operate the compressor for at least one minute before measurement.)

Idle speed [A/C "ON" and gears in "N" or "P" range]:

850±100 rpm

NOTE:

Idle speed cannot be adjusted manually, because the idle speed is automatically adjusted. If the prescribed idle speed cannot be maintained, check the engine control system. <Ref. to EN(H4SO)(diag)-2, Basic Diagnostic Procedure.>

4. Ignition Timing

A: INSPECTION

CAUTION:

After warming-up, engine becomes very hot. Be careful not to burn yourself at measurement.

1) Before checking the ignition timing, check the following item:

(1) Check the air cleaner element is free from clogging, spark plugs are in good condition, and hoses are connected properly.

(2) Check the malfunction indicator light does not illuminate.

2) Warm-up the engine.

3) When checking the ignition timing, connect the timing light to the #1 cylinder spark plug cord and illuminate the timing mark with the timing light.

4) Start the engine and check the ignition timing at idle speed as shown below.

Ignition timing [BTDC/rpm]:

$10^{\circ} \pm 8^{\circ} / 650$ (MT Model)

$15^{\circ} \pm 8^{\circ} / 700$ (AT model)

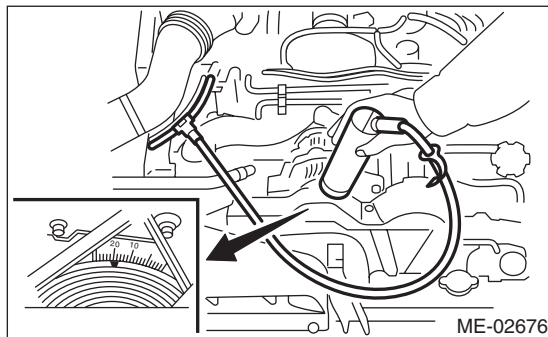

If the timing is not correct, check the ignition control system. <Ref. to EN(H4SO)(diag)-2, Basic Diagnostic Procedure.>

Brought to you by Eris Studios
NOT FOR RESALE

5. Intake Manifold Vacuum

A: INSPECTION

- 1) Warm-up the engine.
- 2) Disconnect the brake vacuum hose from intake manifold, and then install the vacuum gauge.
- 3) Keep the engine at idle speed and read the vacuum gauge indication.

By observing the gauge needle movement, the internal condition of the engine can be diagnosed as described below.

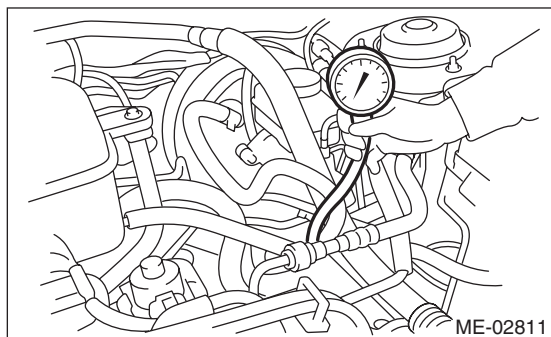

Vacuum pressure (at idling, A/C "OFF"):
Less than -60.0 kPa (-450 mmHg, -17.72 inHg)

Diagnosis of engine condition by measurement of intake manifold vacuum	
Vacuum gauge indication	Possible engine condition
1. Needle is steady but lower than normal position. This tendency becomes more evident as engine temperature rises.	Air leakage around intake manifold gasket, disconnection or damage of vacuum hose
2. Needle intermittently drops to position lower than normal position.	Leakage around cylinder
3. Needle drops suddenly and intermittently from normal position.	Sticky valve
4. When engine speed is gradually increased, needle begins to vibrate rapidly at certain speed, and then vibration increases as engine speed increases.	Weak or broken valve springs
5. Needle vibrates above and below normal position in narrow range.	Defective ignition system

6. Engine Oil Pressure

A: INSPECTION

1) Disconnect the ground cable from the battery.

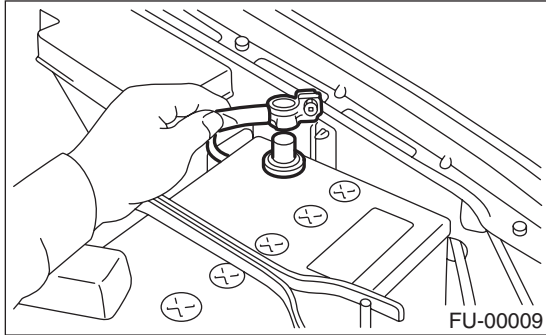

2) Remove the generator from the bracket. <Ref. to SC(H4SO)-14, REMOVAL, Generator.>

3) Disconnect the connector from oil pressure switch.

4) Remove the oil pressure switch. <Ref. to LU(H4SO)-19, REMOVAL, Oil Pressure Switch.>

5) Connect the oil pressure gauge hose to cylinder block.

6) Connect the ground cable to the battery.

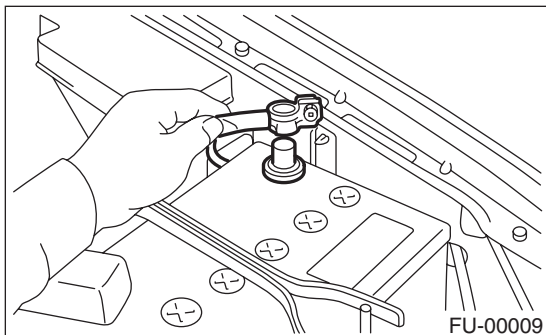

7) Start the engine, and measure the oil pressure.

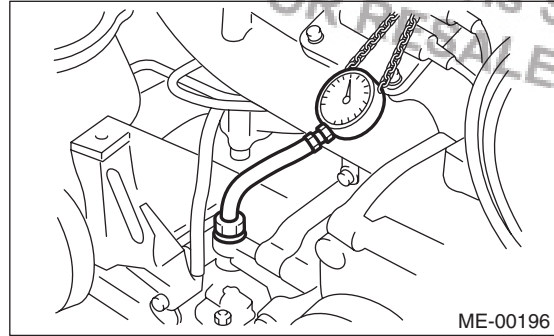

Oil pressure:

Standard

98 kPa (1.0 kgf/cm², 14 psi) or more (at 600 rpm)

294 kPa (3.0 kgf/cm², 43 psi) or more (at 5,000 rpm)

- If the oil pressure is out of specification, check the oil pump, oil filter and lubrication line. <Ref. to LU(H4SO)-21, INSPECTION, Engine Lubrication System Trouble in General.>

- If the oil pressure warning light is ON and oil pressure is within specification, check the oil pressure switch. <Ref. to LU(H4SO)-21, INSPECTION, Engine Lubrication System Trouble in General.>

NOTE:

Standard value is based on an engine oil temperature of 80°C (176°F).

8) After measuring the oil pressure, install the oil pressure switch. <Ref. to LU(H4SO)-19, INSTALLATION, Oil Pressure Switch.>

Tightening torque:

25 N·m (2.5 kgf-m, 18.4 ft-lb)

9) Install the generator and V belt in the reverse order of removal, then adjust the play amount of the V belt. <Ref. to ME(H4SO)-39, INSTALLATION, V-belt.>

7. Fuel Pressure

A: INSPECTION

CAUTION:

Before removing the fuel pressure gauge, release the fuel pressure.

NOTE:

Check or replace the fuel pump and fuel delivery line if the fuel pressure is out of the standard.

1) Release the fuel pressure.

<Ref. to FU(H4SO)-43, RELEASING OF FUEL PRESSURE, PROCEDURE, Fuel.>

2) Disconnect the fuel delivery hose from the fuel damper, and connect the fuel pressure gauge.

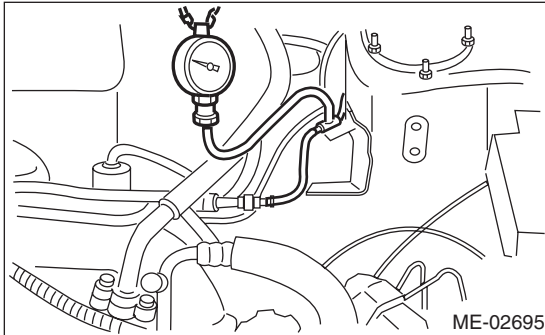

3) Connect the connector of fuel pump relay.

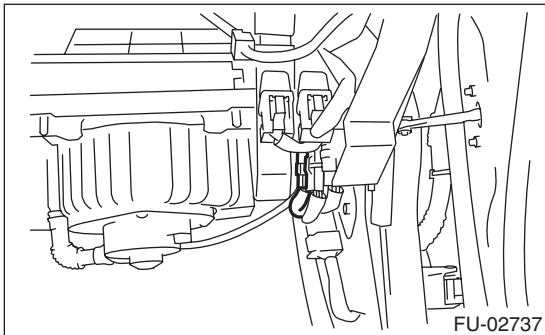

4) Start the engine.

5) Measure the fuel pressure after warming up the engine.

Fuel pressure:

Standard:

339.5 — 360.5 kPa

(3.5 — 3.7 kgf/cm², 49 — 52 psi)

NOTE:

The fuel pressure gauge registers 10 — 20 kPa (0.1 — 0.2 kgf/cm², 1 — 3 psi) higher than standard values during high-altitude operations.

8. Valve Clearance

A: INSPECTION

NOTE:

Inspection and adjustment of valve clearance should be performed while engine is cold.

- 1) Set the vehicle on a lift.
- 2) Lift up the vehicle.
- 3) Remove the under cover.
- 4) Lower the vehicle.
- 5) Disconnect the ground cable from the battery.

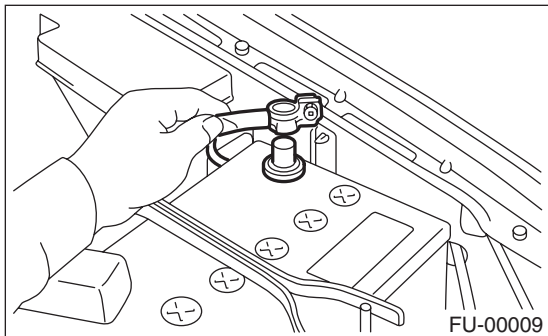

- 6) Remove the timing belt cover (LH).

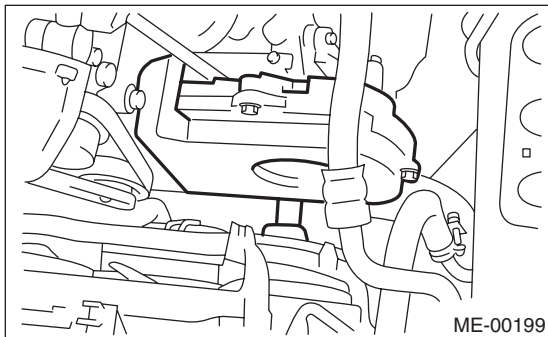

- 7) Remove the fuel injector. <Ref. to FU(H4SO)-30, REMOVAL, Fuel Injector.>

- 8) When inspecting #1 and #3 cylinders:

- (1) Disconnect the spark plug cords from spark plugs RH side. <Ref. to IG(H4SO)-4, RH SIDE, REMOVAL, Spark Plug.>
- (2) Disconnect the PCV hose from the rocker cover (RH).
- (3) Remove the bolts, then remove the rocker cover (RH).

- 9) When inspecting #2 and #4 cylinders:

- (1) Disconnect the spark plug cords from spark plugs (LH side). <Ref. to IG(H4SO)-4, LH SIDE, REMOVAL, Spark Plug.>
- (2) Disconnect the PCV hose from the rocker cover (LH).
- (3) Remove the bolts, then remove the rocker cover (LH).

- 10) Set #1 cylinder piston to top dead center of compression stroke by rotating the crank pulley clockwise using the socket wrench.

NOTE:

When the arrow mark (A) on cam sprocket (LH) comes exactly to the top, #1 cylinder piston is brought to the top dead center of compression stroke.

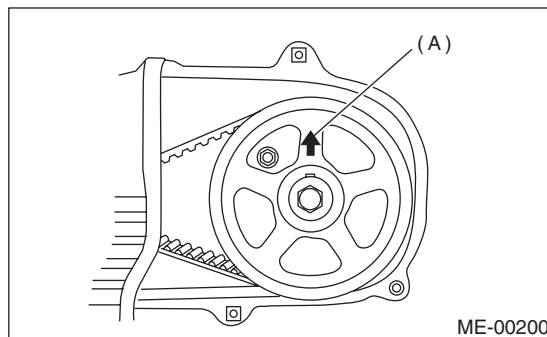

- 11) Measure #1 cylinder valve clearance by using thickness gauge.

NOTE:

- Insert the thickness gauge (A) in as horizontally as possible with respect to the valve stem end face.
- Lift up the vehicle and measure the exhaust valve clearances.

Valve clearance (standard)

Intake:

0.20±0.04 mm (0.0079±0.0016 in)

Exhaust:

0.25±0.04 mm (0.0098±0.0016 in)

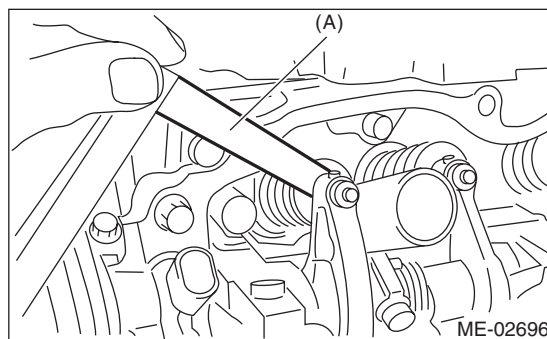

- 12) If necessary, adjust the valve clearance. <Ref. to ME(H4SO)-30, ADJUSTMENT, Valve Clearance.>

Valve Clearance

MECHANICAL

13) Measure the valve clearance in #3, #2 and #4 cylinder in the same measurement procedure as #1 cylinder.

NOTE:

- Be sure to set the cylinder pistons to their respective top dead centers on compression stroke before measuring valve clearances.
- By rotating the crank pulley clockwise every 180° from the state that #1 cylinder piston is on the top dead center of compression stroke, #3, #2 and #4 cylinder pistons come to the top dead center of compression stroke in this order.

14) After inspection, install the related parts in the reverse order of removal.

NOTE:

Use a new rocker cover gasket and rocker cover washer.

B: ADJUSTMENT

NOTE:

Perform adjustment of valve clearance while the engine is cold.

1) Set #1 cylinder piston to top dead center of compression stroke by rotating the crank pulley clockwise using the socket wrench.

NOTE:

When the arrow mark (A) on cam sprocket (LH) comes exactly to the top, #1 cylinder piston is brought to the top dead center of compression stroke.

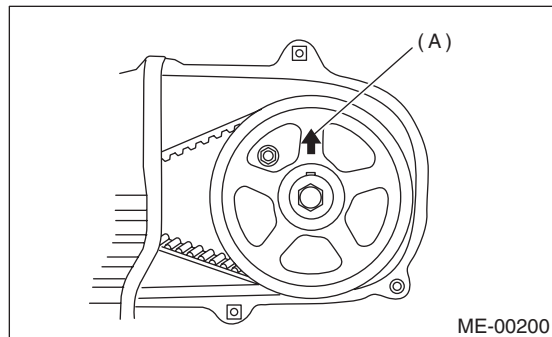

2) Adjust the #1 cylinder valve clearance.

- (1) Loosen the valve rocker nut and screw.
- (2) Set a suitable thickness gauge.
- (3) While noting the valve clearance, tighten the valve rocker adjusting screw.
- (4) When the specified valve clearance is obtained, tighten the valve rocker nut.

Tightening torque:

9.75 N·m (1.0 kgf·m, 7.2 ft·lb)

NOTE:

- Insert a thickness gauge in as horizontally as possible with respect to the valve stem end face.
- Lift up the vehicle and adjust the exhaust valve clearances.

Valve clearance

Intake:

0.20±0.04 mm (0.0079±0.0016 in)

Exhaust:

0.25±0.04 mm (0.0098±0.0016 in)

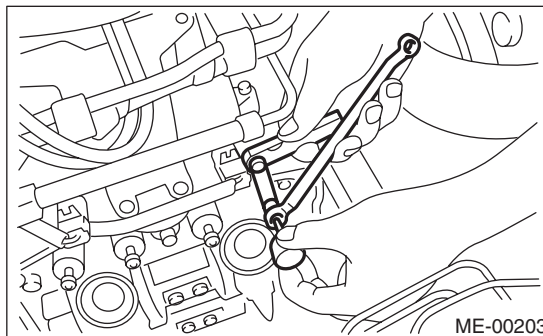

3) Adjust the valve clearance in #3, #2 and #4 cylinder in the same adjustment procedure as #1 cylinder.

NOTE:

- Be sure to set the cylinder pistons to their respective top dead centers on compression stroke before adjusting valve clearances.
 - By rotating the crank pulley clockwise every 180° from the state that #1 cylinder piston is on the top dead center of compression stroke, #3, #2 and #4 cylinder pistons come to the top dead center of compression stroke in this order.
- 4) Ensure the valve clearances of each cylinder are within specifications. If necessary, readjust the valve clearances.

9. Engine Assembly

A: REMOVAL

- 1) Set the vehicle on a lift.
- 2) Open the front hood fully and support with the front food stay.
- 3) Collect the refrigerant from the A/C system.
<Ref. to AC-19, PROCEDURE, Refrigerant Recovery Procedure.>
- 4) Release the fuel pressure.
<Ref. to FU(H4SO)-43, RELEASING OF FUEL PRESSURE, PROCEDURE, Fuel.>
- 5) Disconnect the ground cable from the battery.

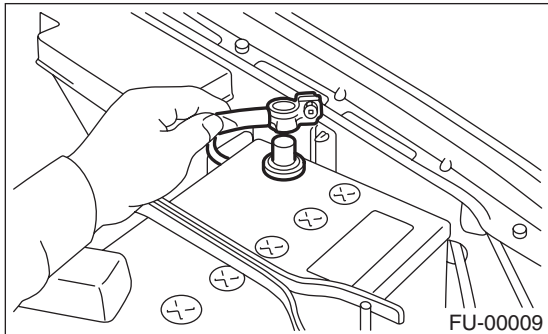

- 6) Open the fuel filler flap lid, and remove the fuel filler cap.
- 7) Remove the air intake duct, air cleaner case and air intake chamber.
<Ref. to IN(H4SO)-7, REMOVAL, Air Intake Duct.>
<Ref. to IN(H4SO)-5, REMOVAL, Air Cleaner Case.> <Ref. to IN(H4SO)-6, REMOVAL, Air Intake Chamber.>
- 8) Remove the under cover.
- 9) Remove the radiator from the vehicle. <Ref. to CO(H4SO)-23, REMOVAL, Radiator.>
- 10) Disconnect the A/C pressure hoses from A/C compressor.
- 11) Remove the air intake chamber stay.

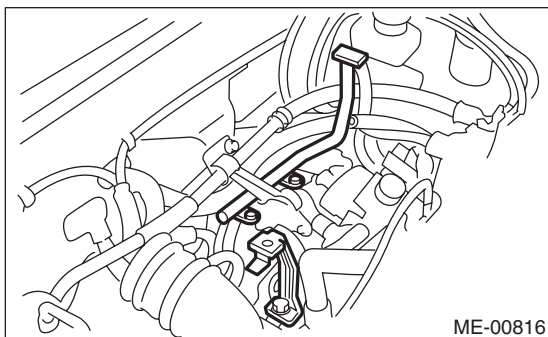

- 12) Disconnect the following connectors and cables.

- (1) Front oxygen (A/F) sensor connector
- (2) Rear oxygen sensor connector

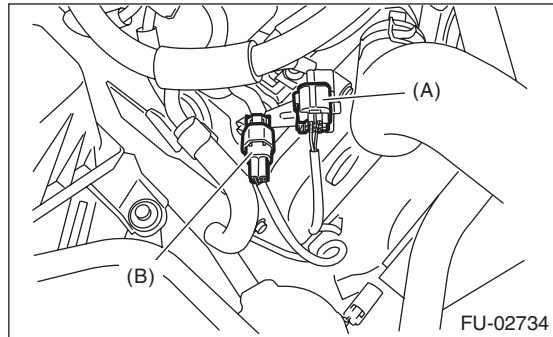

- (A) Front oxygen (A/F) sensor connector
(B) Rear oxygen sensor connector

- (3) Engine ground cable

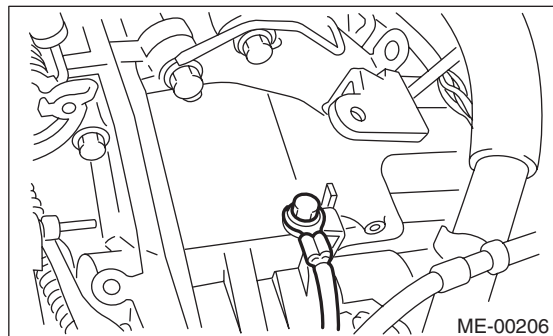

- (4) Engine harness connectors

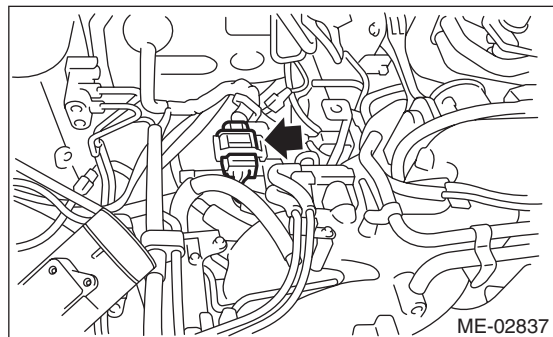

- (5) Generator connector and terminal

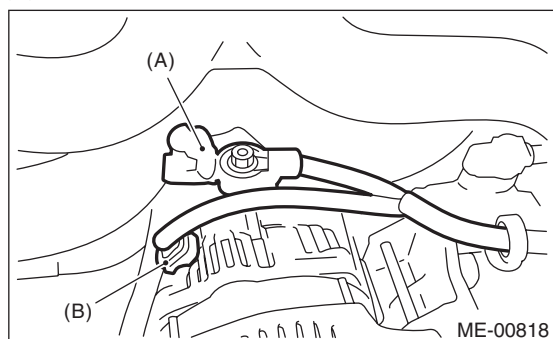

- (A) Terminal
(B) Generator connector

(6) A/C compressor connector

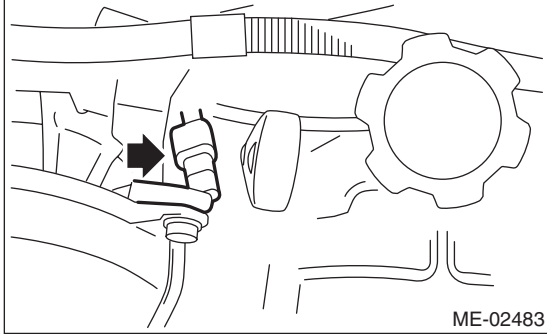

(7) Power steering switch connector

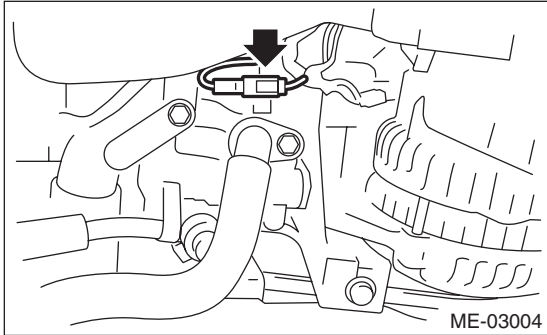

13) Disconnect the following hoses.

(1) Brake booster vacuum hose

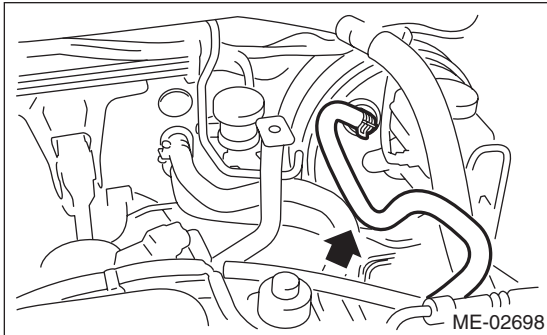

(2) Heater inlet and outlet hoses

14) Remove the power steering pump from the bracket.

(1) Loosen the lock bolt and slider bolt, and remove the front side V-belt. <Ref. to ME(H4SO)-39, FRONT SIDE BELT, REMOVAL, V-belt.>

(2) Remove the pipe along with the bracket.

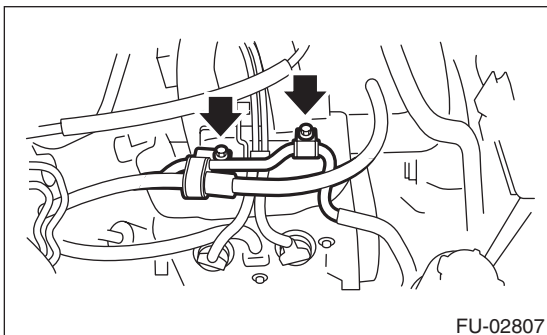

(3) Remove the bolts which secure the power steering pump to the bracket.

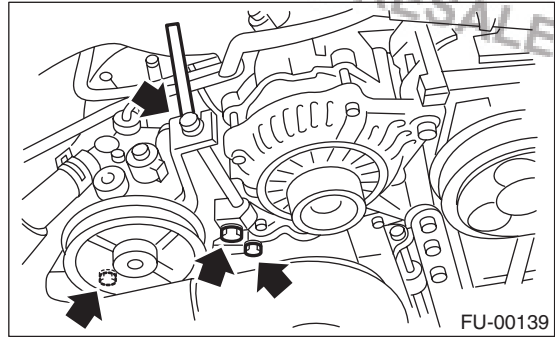

(4) Pull the power steering reserve tank up and remove from the bracket.

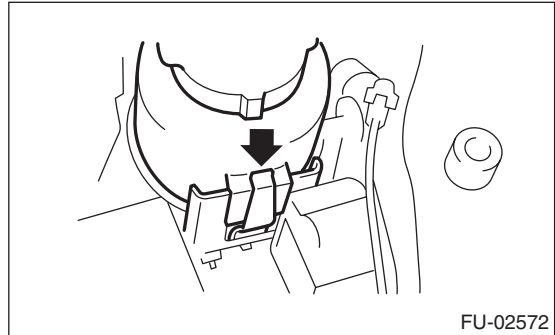

(5) Set the power steering pump towards the right side wheel apron in order to avoid falling.

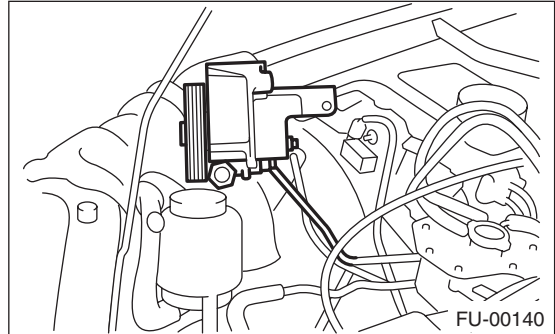

15) Remove the front and center exhaust pipes. <Ref. to EX(H4SO)-4, REMOVAL, Front Exhaust Pipe.>

16) Remove the bolts and nuts which hold lower side of transmission to engine.

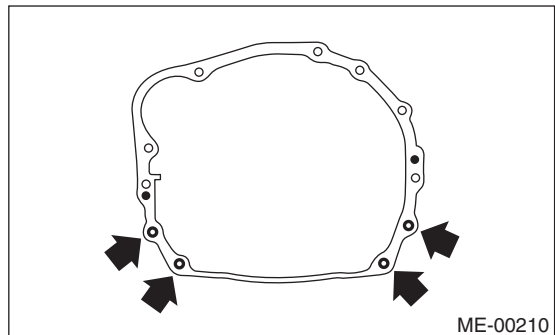

17) Remove the nuts which install front cushion rubber onto front crossmember.

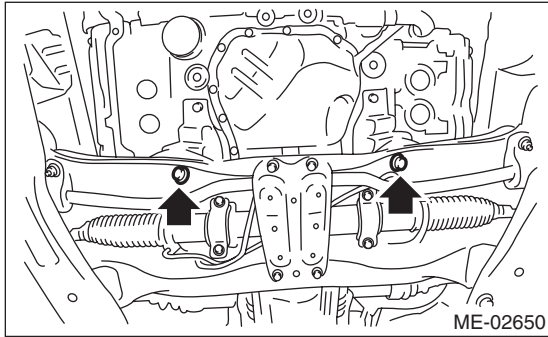

18) Separate the torque converter clutch from drive plate. (AT model)

- (1) Lower the vehicle.
- (2) Remove the service hole plug.
- (3) Remove the bolts which hold torque converter clutch to drive plate.
- (4) Remove all bolts while turning the crankshaft with a socket wrench.

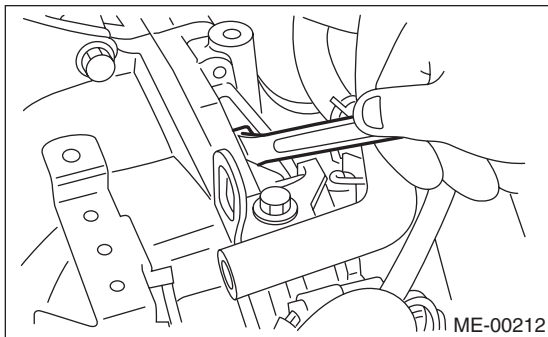

19) Remove the pitching stopper.

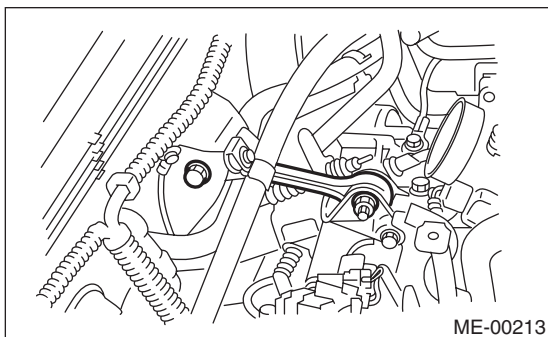

20) Disconnect the fuel hoses from fuel pipe.
 (1) Disconnect the quick connector on the fuel delivery line by pushing the ST in the direction of the arrow.

ST 42099AE000 CONNECTOR REMOVER

(2) Remove the clip and disconnect the evaporation hose from the pipe.

CAUTION:

- Be careful not to spill fuel.
- Catch the fuel from hoses using a container or cloth.

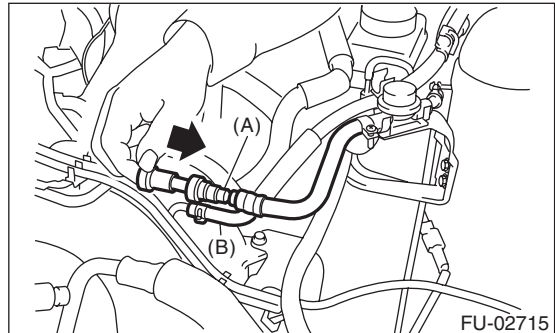

- (A) Fuel delivery hose
- (B) Evaporation hose

21) Support the engine with a lifting device and wire ropes.

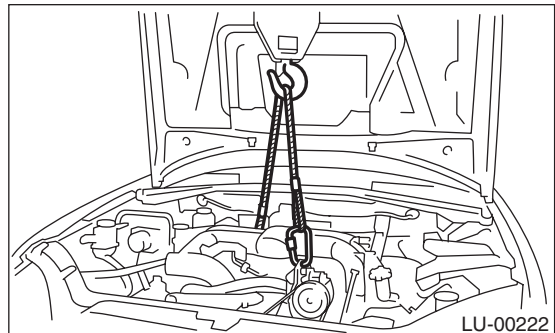

22) Support the transmission with a garage jack.

CAUTION:

Doing this is very important to prevent the transmission from lowering due to its own weight.

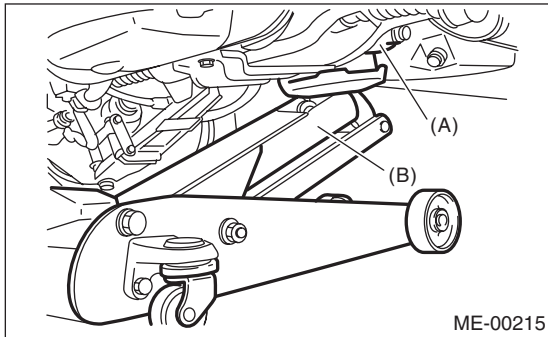

(A) Transmission
(B) Garage jack

CAUTION:

Before removing the engine away from transmission, check to be sure no work has been overlooked.

23) Separation of engine and transmission.

- (1) Remove the starter. <Ref. to SC(H4SO)-8, REMOVAL, Starter.>
- (2) Remove the bolts which hold upper side of transmission to engine.

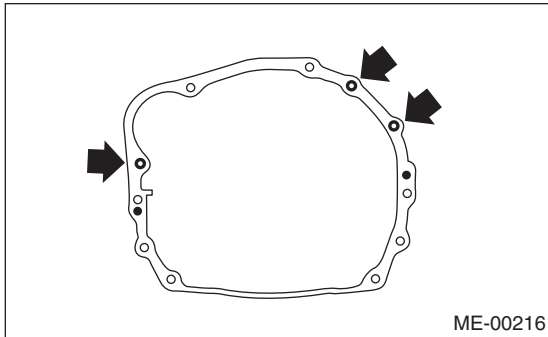

24) Attach the ST to the converter case. (AT model)

ST 498277200 STOPPER SET

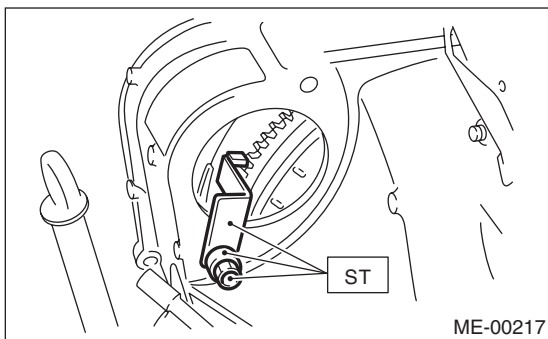

25) Remove the engine from vehicle.

- (1) Slightly raise the engine.
- (2) Raise the transmission with garage jack.
- (3) Move the engine horizontally until main shaft is withdrawn from clutch cover.
- (4) Slowly move the engine away from engine compartment.

NOTE:

Be careful not to damage adjacent parts or body panels with crank pulley, oil level gauge, etc.

26) Remove the front cushion rubbers.

B: INSTALLATION

1) Install the front cushion rubbers.

Tightening torque:

35 N·m (3.6 kgf-m, 25.8 ft-lb)

2) Position the engine in engine compartment and align it with transmission.

NOTE:

Be careful not to damage adjacent parts or body panels with crank pulley, oil level gauge, etc.

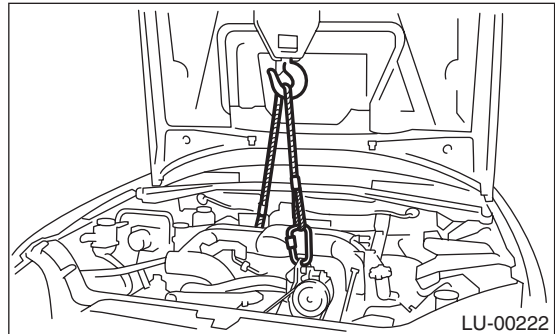

3) Apply a small amount of grease to the splines of the main shaft. (MT model)

4) Tighten the bolts which hold upper side of transmission to engine.

Tightening torque:

50 N·m (5.1 kgf-m, 36.9 ft-lb)

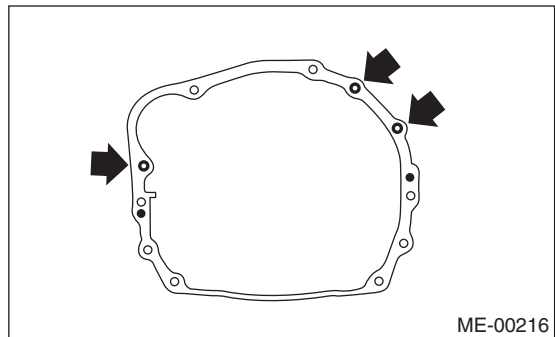

- 5) Remove the lifting device and wire ropes.
- 6) Remove the garage jack.
- 7) Install the pitching stopper.

Tightening torque:

T1: 50 N·m (5.1 kgf·m, 36.9 ft·lb)

T2: 58 N·m (5.9 kgf·m, 42.8 ft·lb)

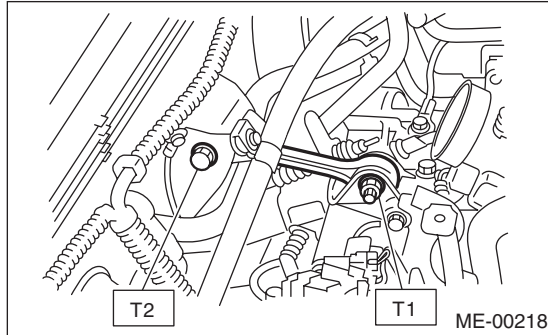

- 8) Remove the ST from converter case. (AT model)

NOTE:

Be careful not to drop the ST into the converter case when removing the ST.

ST 498277200 STOPPER SET

- 9) Install the starter. <Ref. to SC(H4SO)-8, INSTALLATION, Starter.>

- 10) Install the torque converter clutch to drive plate. (AT model)

- (1) Tighten the bolts which hold torque converter clutch to drive plate.
- (2) Tighten all bolts while rotating the engine in the rotation direction a little at a time using socket wrench.

NOTE:

Be careful not to drop bolts into the torque converter clutch housing.

Tightening torque:

25 N·m (2.5 kgf·m, 18.4 ft·lb)

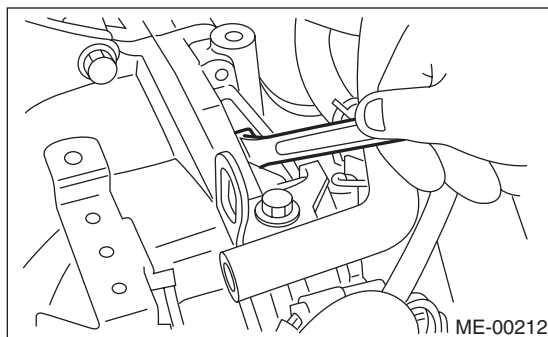

- (3) Attach the service hole plug to prevent entry of foreign objects.

- 11) Attach the power steering pump to the bracket.
 - (1) Attach the power steering tank to the bracket.

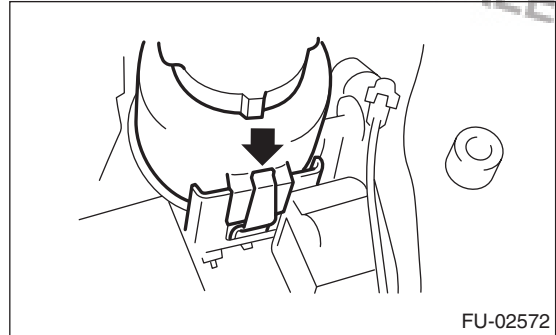

- (2) Install the power steering pump to the bracket, and tighten the bolts.

Tightening torque:

22 N·m (2.2 kgf·m, 16 ft·lb)

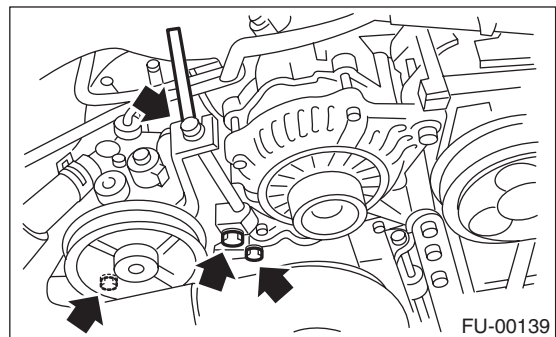

- (3) Install the pipe together with the bracket.

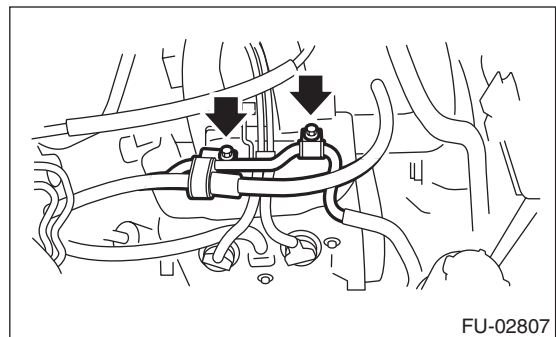

- (4) Connect the power steering switch connector.

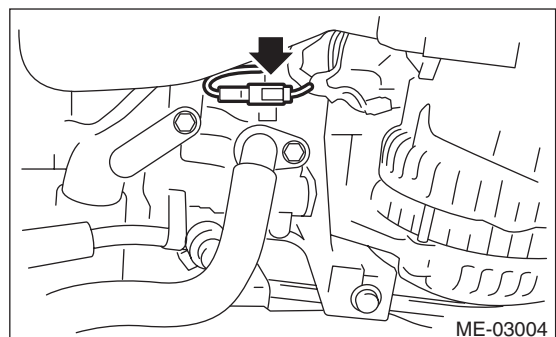

(5) Install and adjust the front side belt. <Ref. to ME(H4SO)-39, FRONT SIDE BELT, INSTALLATION, V-belt.>

12) Lift up the vehicle.

13) Tighten the bolts and nuts which hold lower side of the transmission to engine.

Tightening torque:

50 N·m (5.1 kgf-m, 36.9 ft-lb)

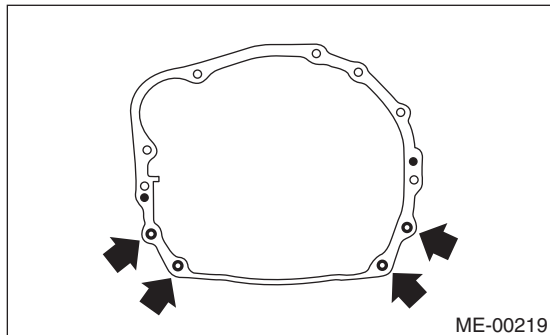

14) Tighten the nuts which install the front cushion rubber onto crossmember.

Tightening torque:

85 N·m (8.7 kgf-m, 63 ft-lb)

NOTE:

Make sure the front cushion rubber mounting bolts (A) and locator (B) are securely installed.

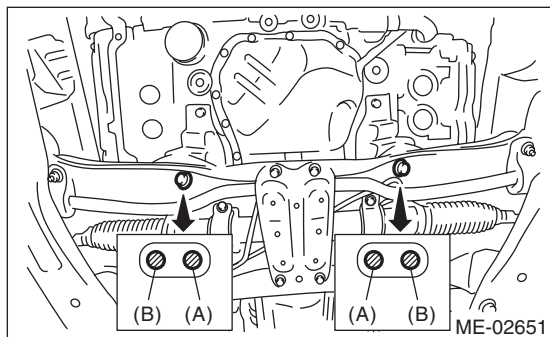

15) Install the front and center exhaust pipe. <Ref. to EX(H4SO)-5, INSTALLATION, Front Exhaust Pipe.>

16) Lower the vehicle.

17) Connect the following hoses.

- (1) Fuel delivery hose and evaporation hose
- (2) Heater inlet and outlet hoses
- (3) Brake booster vacuum hose

18) Connect the following connectors.

- (1) Front oxygen (A/F) sensor connector
- (2) Rear oxygen sensor connector
- (3) Engine harness connectors
- (4) Generator connector and terminal
- (5) A/C compressor connector

19) Install the air intake chamber stay.

Tightening torque:

16 N·m (1.6 kgf-m, 11.6 ft-lb)

20) Install the engine ground cable.

Tightening torque:

14 N·m (1.4 kgf-m, 10.1 ft-lb)

21) Install the A/C pressure hoses.

<Ref. to AC-35, INSTALLATION, Hose and Tube.>

22) Install the radiator to vehicle. <Ref. to CO(H4SO)-24, INSTALLATION, Radiator.>

23) Install the air intake duct, air cleaner case and air intake chamber. <Ref. to IN(H4SO)-7, INSTALLATION, Air Intake Duct.> <Ref. to IN(H4SO)-5, INSTALLATION, Air Cleaner Case.> <Ref. to IN(H4SO)-6, INSTALLATION, Air Intake Chamber.>

24) Install the under cover.

25) Install the battery in the vehicle, and connect cables.

26) Fill engine coolant.

<Ref. to CO(H4SO)-16, FILLING OF ENGINE COOLANT, REPLACEMENT, Engine Coolant.>

27) Check the ATF level and replenish it if necessary.

<Ref. to 4AT-28, INSPECTION, Automatic Transmission Fluid.>

28) Charge the A/C system with refrigerant. <Ref. to AC-20, PROCEDURE, Refrigerant Charging Procedure.>

29) Remove the front hood stay, and close the front hood.

30) Lower the vehicle from the lift.

C: INSPECTION

1) Check that pipes, hoses, connectors and clamps are installed firmly.

2) Check the engine coolant and ATF are at specified levels.

3) Start the engine and check for exhaust gas, engine coolant, leaks of fuel, etc. Also check for noise and vibrations.

10.Engine Mounting

A: REMOVAL

- 1) Remove the engine unit. <Ref. to ME(H4SO)-31, REMOVAL, Engine Assembly.>
- 2) Remove the engine mounting from engine assembly.

B: INSTALLATION

Install in the reverse order of removal.

Tightening torque:

Engine mounting:

35 N·m (3.6 kgf·m, 25.8 ft-lb)

C: INSPECTION

Make sure that no crack or other damages do not exist.

Brought to you by Eris Studios
NOT FOR RESALE

11. Preparation for Overhaul

A: PROCEDURE

1) After removing the engine from body, secure it to ST in the following procedure.

- ST1 498457000 ENGINE STAND ADAPTER
RH
- ST2 498457100 ENGINE STAND ADAPTER
LH
- ST3 499817100 ENGINE STAND

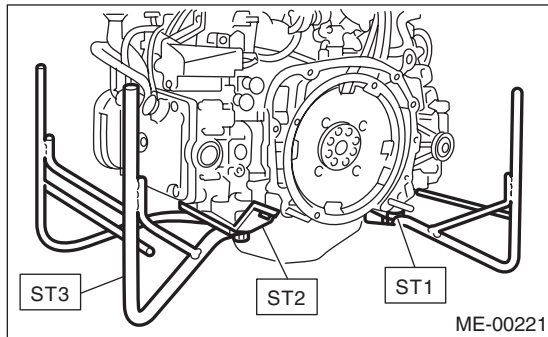

2) In this section the procedures described under each index are all connected and stated in order. The procedure for overhauling of the engine will be completed when you go through all steps in the process.

Therefore, in this section, to conduct the particular procedure within the flow of a section, you need to go back and conduct the procedure described previously in order to do that particular procedure.

12.V-belt

A: REMOVAL

NOTE:

Perform the work with the engine installed to body when replacing a single part.

1. FRONT SIDE BELT

- 1) Remove the V-belt covers.

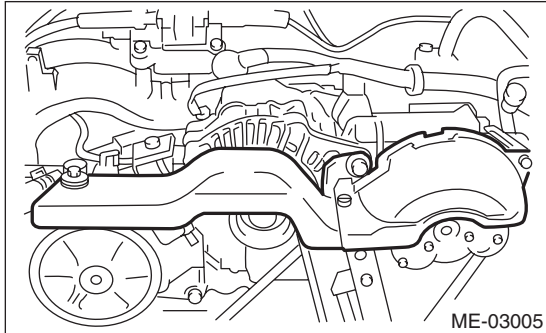

- 2) Loosen the lock bolt (A).
- 3) Loosen the slider bolt (B).
- 4) Remove the front side belt (C).

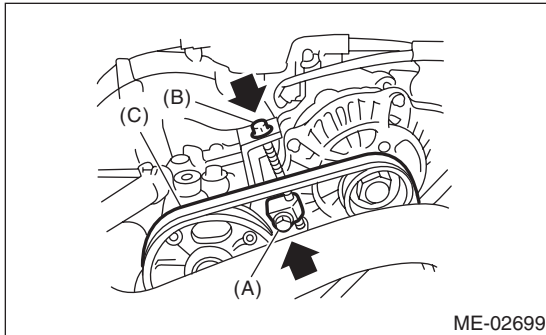

2. REAR SIDE BELT

- 1) Loosen the lock nut (A).
- 2) Loosen the slider bolt (B).

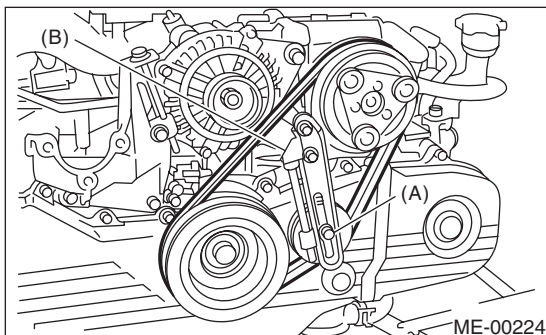

- 3) Remove the rear side belt.

- 4) Remove the belt tensioner.

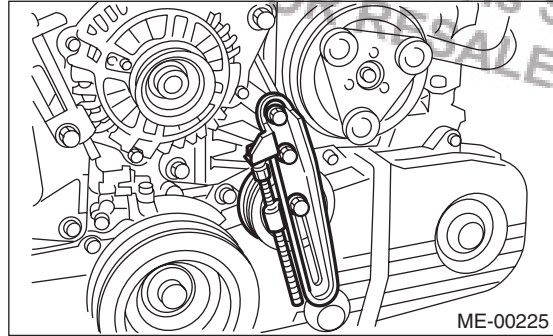

B: INSTALLATION

CAUTION:

Wipe off any oil and water on the belt and pulley.

1. FRONT SIDE BELT

- 1) Install the front side V belt (C), and tighten the slider bolt to obtain the specified belt tension. <Ref. to ME(H4SO)-40, INSPECTION, V-belt.>
- 2) Tighten the lock bolt (A).
- 3) Tighten the slider bolt (B).

Tightening torque:

Lock bolt (A):

25 N·m (2.5 kgf-m, 18.4 ft-lb)

Slider bolt (B):

8 N·m (0.8 kgf-m, 5.9 ft-lb)

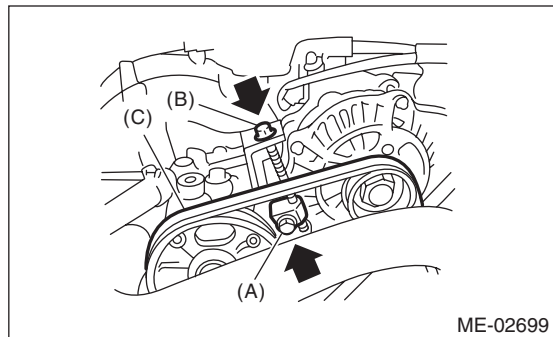

2. REAR SIDE BELT

- 1) Install the belt tensioner.
- 2) Install the rear side belt, and tighten the slider bolt (B) so as to obtain the specified belt tension. <Ref. to ME(H4SO)-40, INSPECTION, V-belt.>

V-belt

MECHANICAL

3) Tighten the lock nut (A).

Tightening torque:

Lock nut (A):

23 N·m (2.3 kgf·m, 17.0 ft·lb)

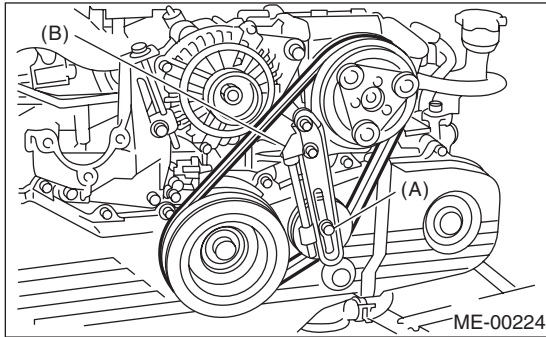

C: INSPECTION

- 1) Replace the belts, if crack, fraying or wear is found.
- 2) Remove the V-belt cover and reservoir tank. (with belt tension gauge)
- 3) Check the V-belt tension and adjust it if necessary by changing the generator installing position or idler pulley installing position.

Belt tension (with belt tension gauge):

(A)

When installing new parts:

640 — 780 N (65 — 80 kgf, 144 — 175 lbf)

At inspection

490 — 640 N (50 — 65 kgf, 110 — 144 lbf)

(B)

When installing new parts:

650 — 750 N (66 — 76 kgf, 146 — 169 lbf)

At inspection

350 — 450 N (36 — 46 kgf, 78 — 101 lbf)

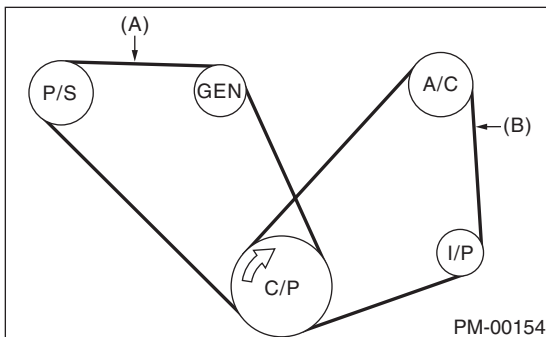

- (A) Front side belt
- (B) Rear side belt
- C/P Crank pulley
- GEN Generator
- P/S Power steering oil pump pulley
- A/C Air conditioning compressor pulley
- I/P Idler pulley

Belt tension (without belt tension gauge)

(A)

When installing new parts:

7 — 9 mm (0.276 — 0.354 in)

At inspection:

9 — 11 mm (0.354 — 0.433 in)

(B)

When installing new parts:

7.5 — 8.5 mm (0.295 — 0.335 in)

At inspection:

9.0 — 10.0 mm (0.354 — 0.394 in)

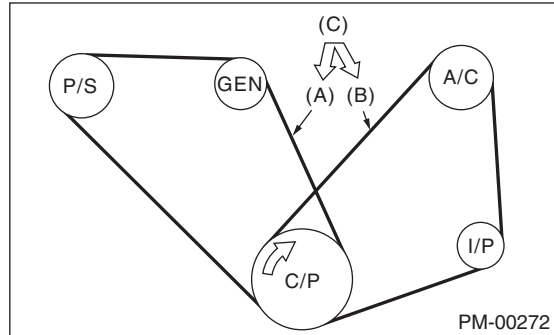

- (A) Front side belt
- (B) Rear side belt
- (C) 98 N (10 kgf, 22 lbf)
- C/P Crank pulley
- GEN Generator
- P/S Power steering oil pump pulley
- A/C Air conditioning compressor pulley
- I/P Idler pulley

13. Crank Pulley

A: REMOVAL

NOTE:

Perform the work with the engine installed to body when replacing a single part.

1) Remove the V-belts. <Ref. to ME(H4SO)-39, REMOVAL, V-belt.>

2) Remove the crank pulley bolt. To lock the crankshaft, use ST.

ST 499977100 CRANK PULLEY WRENCH

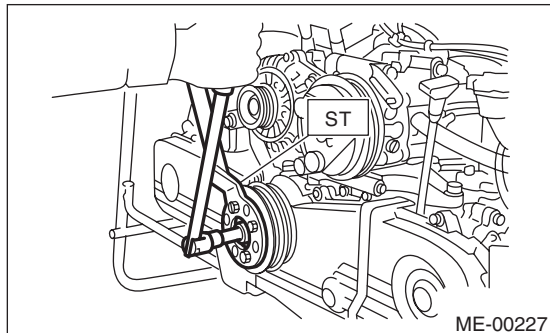

3) Remove the crank pulley.

B: INSTALLATION

1) Install the crank pulley.

2) Install the pulley bolt.

To lock the crankshaft, use ST.

ST 499977100 CRANK PULLEY WRENCH

(1) Clean the crankshaft thread using compressed air.

(2) Apply engine oil to the crank pulley bolt seat and thread.

(3) Tighten the bolts temporarily with tightening torque of 44 N·m (4.5 kgf-m, 33 ft-lb).

(4) Tighten the crank pulley bolts.

Tightening torque:

180 N·m (18.4 kgf-m, 132.8 ft-lb)

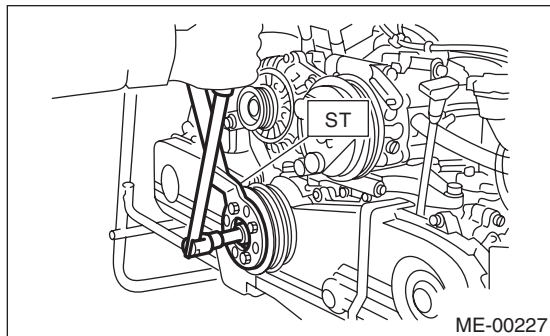

3) Check that the tightening angle of the crank pulley bolt is 65° or more. Perform the following procedures when less than 65°.

CAUTION:

If the tightening angle of the crank pulley bolt is less than 65°, the bolt is damaged. In this case, the bolt must be replaced with a new part.

(1) Replace the crank pulley bolts with new parts and clean.

Crank pulley bolt:

Part No. 12369AA011

(2) Clean the crankshaft thread using compressed air.

(3) Apply engine oil to the crank pulley bolt seat and thread.

(4) Tighten the bolts temporarily with tightening torque of 44 N·m (4.5 kgf-m, 33 ft-lb).

(5) Tighten the crank pulley bolts 65° to 75°.

NOTE:

Conduct the tightening procedures by confirming the turning angle of crank pulley bolt referring to the gauge indicated on timing belt cover.

4) Install the belt tensioner.

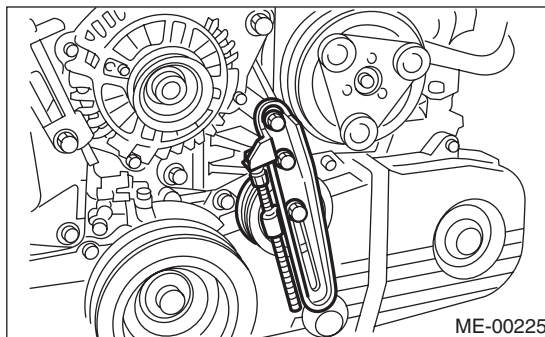

5) Install the V-belts. <Ref. to ME(H4SO)-39, INSTALLATION, V-belt.>

C: INSPECTION

1) Make sure the V-belt is not worn or otherwise damaged.

2) Check the tension of the belt. <Ref. to ME(H4SO)-40, INSPECTION, V-belt.>

14. Timing Belt Cover

A: REMOVAL

NOTE:

Perform the work with the engine installed to body when replacing a single part.

- 1) Remove the V-belts. <Ref. to ME(H4SO)-39, REMOVAL, V-belt.>
- 2) Remove the crank pulley. <Ref. to ME(H4SO)-41, REMOVAL, Crank Pulley.>
- 3) Remove the timing belt cover (LH).
- 4) Remove the front timing belt cover.

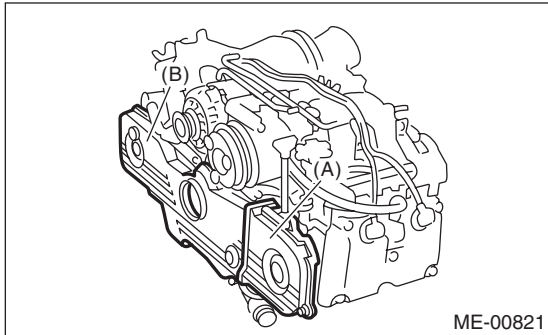

(A) Timing belt cover (LH)

(B) Front timing belt cover

B: INSTALLATION

- 1) Install the front timing belt cover.

Tightening torque:

5 N·m (0.5 kgf·m, 3.6 ft·lb)

- 2) Install the timing belt cover (LH).

Tightening torque:

5 N·m (0.5 kgf·m, 3.6 ft·lb)

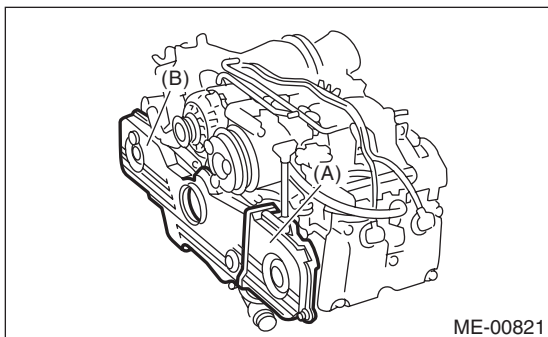

(A) Timing belt cover (LH)

(B) Front timing belt cover

- 3) Install the crank pulley. <Ref. to ME(H4SO)-41, INSTALLATION, Crank Pulley.>
- 4) Install the V-belts. <Ref. to ME(H4SO)-39, INSTALLATION, V-belt.>

C: INSPECTION

Check the cover for damage.

15. Timing Belt

A: REMOVAL

1. TIMING BELT

NOTE:

Perform the work with the engine installed to body when replacing a single part. For operation procedures, refer to "Timing Belt" in the PM section. <Ref. to PM-12, Timing Belt.>

- 1) Remove the V-belts. <Ref. to ME(H4SO)-39, REMOVAL, V-belt.>
- 2) Remove the crank pulley. <Ref. to ME(H4SO)-41, REMOVAL, Crank Pulley.>
- 3) Remove the timing belt cover. <Ref. to ME(H4SO)-42, REMOVAL, Timing Belt Cover.>
- 4) Remove the timing belt guide. (MT model)

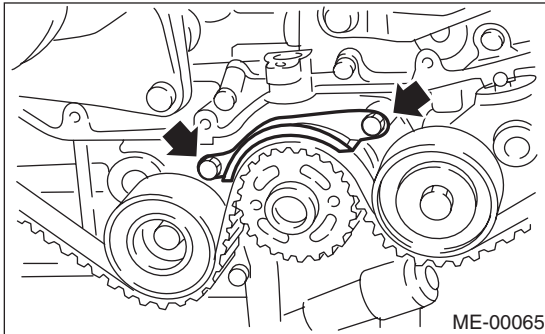

5) If the alignment mark or arrow mark (which indicates the direction of rotation) on timing belt fade away, put new marks before removing the timing belt as shown in procedures below.

(1) Use the ST to turn crankshaft. Align the mark (a) of sprocket to the cylinder block notch (b), and then ensure the right side cam sprocket mark (c), cam cap and cylinder head matching surface (d) or left side cam sprocket mark (e), timing belt cover notch (f) are properly adjusted.

ST 499987500 CRANKSHAFT SOCKET

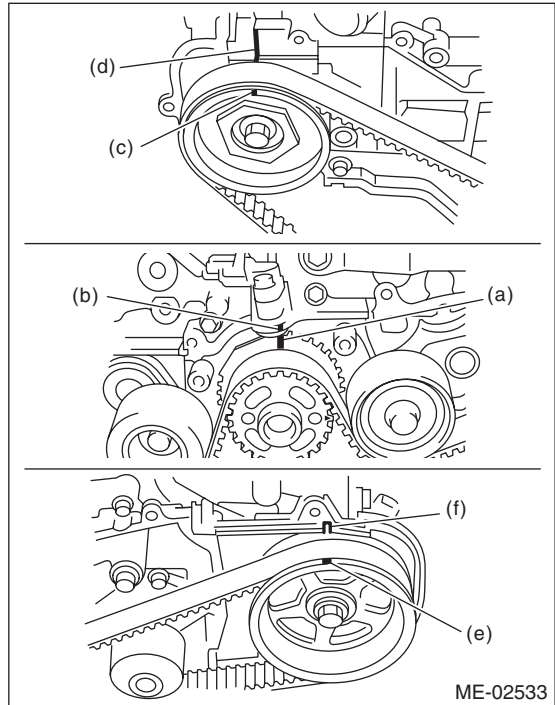
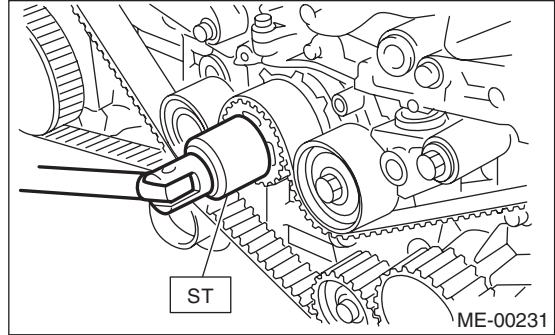

(2) Using white paint, put an alignment mark or an arrow mark on timing belts in relation to the crank sprocket and cam sprockets.

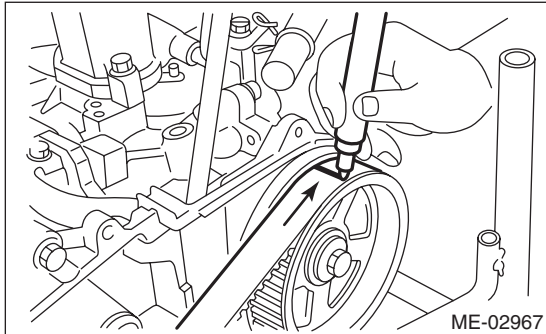

Specified data:

Z₁: 46.8 teeth

Z₂: 43.7 teeth

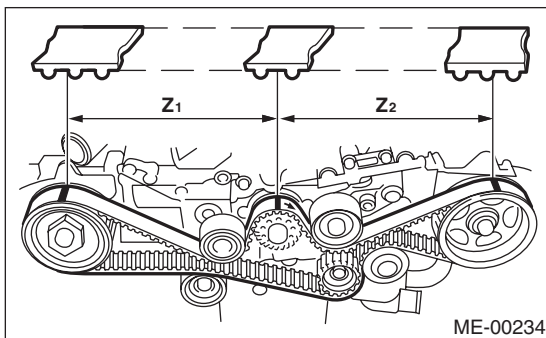

6) Remove the belt idler (No. 2).

7) Remove the belt idler No. 2.

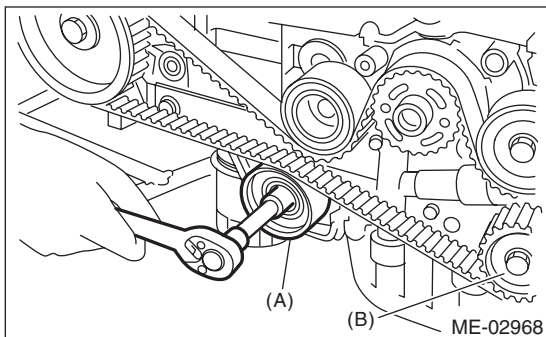

(A) Belt idler (No. 2)

(B) Belt idler No. 2

8) Remove the timing belt.

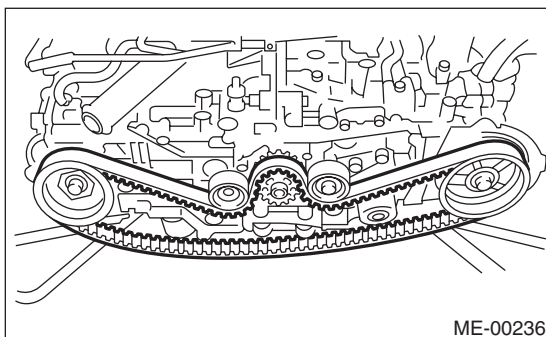

2. BELT IDLER AND AUTOMATIC BELT TENSION ADJUSTER ASSEMBLY

1) Remove the belt idler (No. 1).

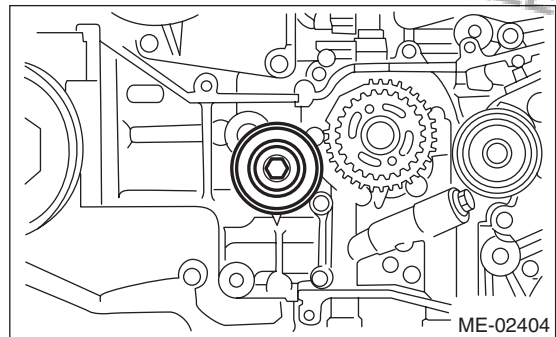

2) Remove the automatic belt tension adjuster assembly.

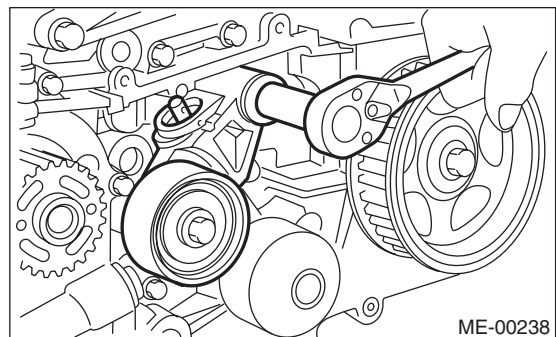

B: INSTALLATION

1. AUTOMATIC BELT TENSION ADJUSTER ASSEMBLY AND BELT IDLER

1) Preparation for installation of automatic belt tension adjuster assembly.

CAUTION:

- Always use a vertical type pressing tool to move the adjuster rod down.
- Do not use a lateral type vise.
- Push the adjuster rod vertically.
- Press-in the push adjuster rod gradually taking three minutes or more.
- Do not allow press pressure to exceed 9,807 N (1,000 kgf, 2,205 lbf).
- Push in the adjuster rod to the end face of the cylinder. Do not push in the adjuster rod farther than the end face of the cylinder. Doing so may damage the cylinder.
- Do not release the press pressure until stopper pin is completely inserted.

(1) Attach the automatic belt tension adjuster assembly to vertical pressing tool.

(2) Slowly move the adjuster rod down with a pressure of 294 N (30 kgf, 66 lbf) or more until the adjuster rod is aligned with the stopper pin hole in the cylinder.

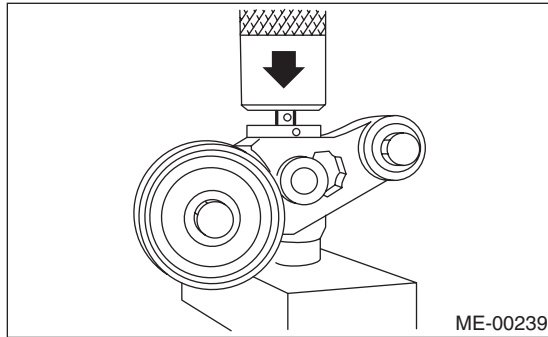

(3) With a 2 mm (0.08 in) dia. stopper pin or a 2 mm (0.08 in) (nominal) dia. hex wrench inserted into the stopper pin hole in cylinder, secure the adjuster rod.

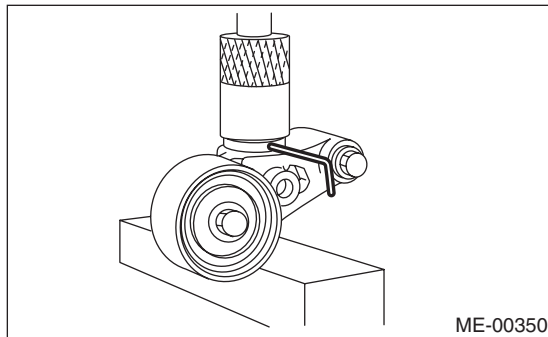

2) Install the automatic belt tension adjuster assembly.

Tightening torque:

39 N·m (4.0 kgf·m, 28.9 ft·lb)

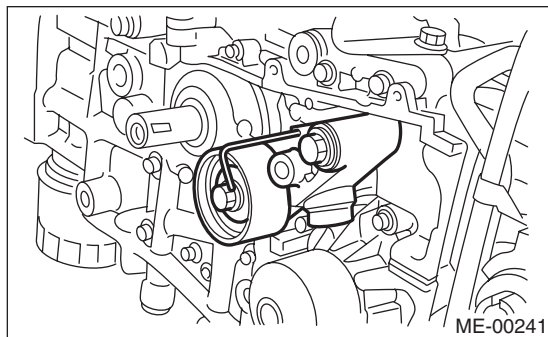

3) Install the belt idler (No. 1).

Tightening torque:

39 N·m (4.0 kgf·m, 28.9 ft·lb)

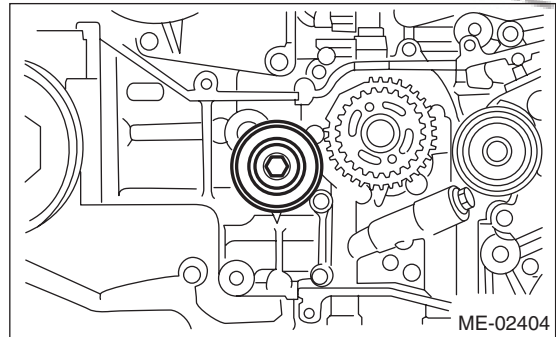

2. TIMING BELT

1) Prepare for installation of the automatic belt tension adjuster assembly. <Ref. to ME(H4SO)-44, AUTOMATIC BELT TENSION ADJUSTER ASSEMBLY AND BELT IDLER, INSTALLATION, Timing Belt.>

2) Turn the camshaft sprocket No. 2 using ST1, and turn the camshaft sprocket No. 1 using ST2 so that their alignment marks (A) come to top positions.

ST1 18231AA010 CAM SPROCKET WRENCH

NOTE:

CAM SPROCKET WRENCH (499207100) can also be used.

ST2 499207400 CAM SPROCKET WRENCH

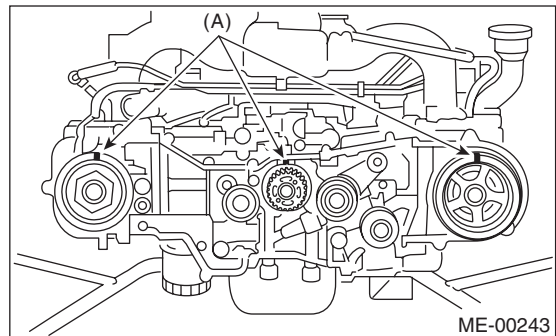

3) While aligning the alignment mark (B) on timing belt with the mark (A) on sprockets, position the timing belt properly.

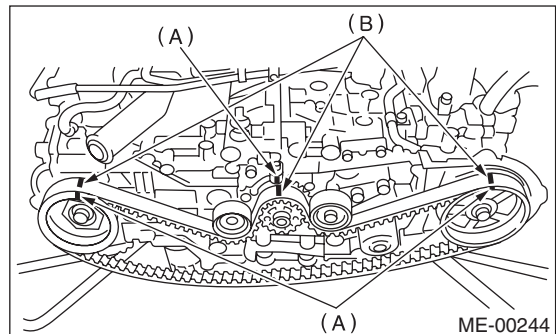

Timing Belt

MECHANICAL

4) Install the belt idler No. 2.

Tightening torque:

39 N·m (4.0 kgf·m, 28.9 ft·lb)

5) Install the belt idler (No. 2).

Tightening torque:

39 N·m (4.0 kgf·m, 28.9 ft·lb)

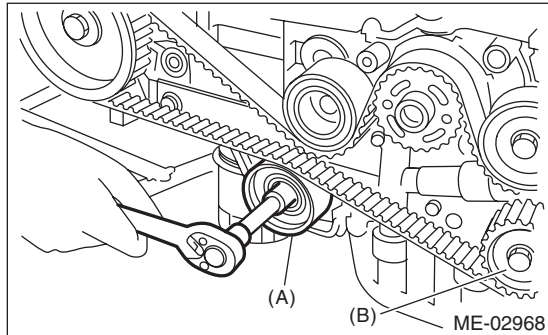

- (A) Belt idler (No. 2)
- (B) Belt idler No. 2

6) After ensuring the marks on timing belt and camshaft sprockets are aligned, remove the stopper pin from belt tension adjuster.

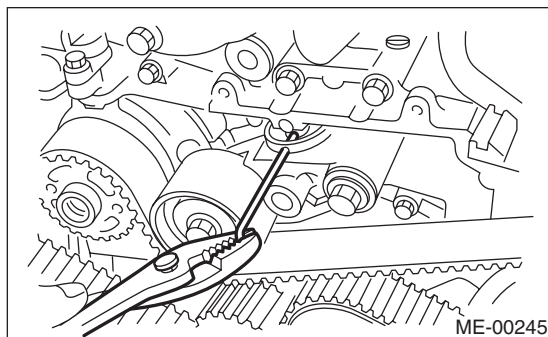

7) Install the timing belt guide. (MT model)

(1) Temporarily tighten the bolts mounting the timing belt guide.

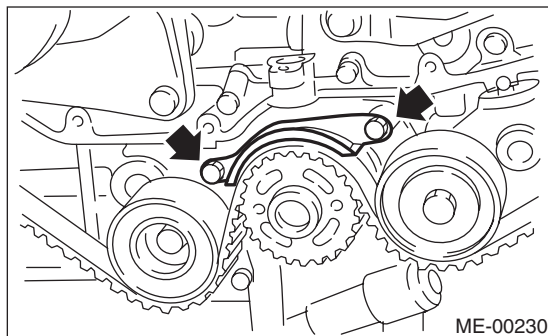

(2) Check and adjust the clearance between timing belt and timing belt guide by using thickness gauge.

Clearance:

1.0±0.5 mm (0.039±0.020 in)

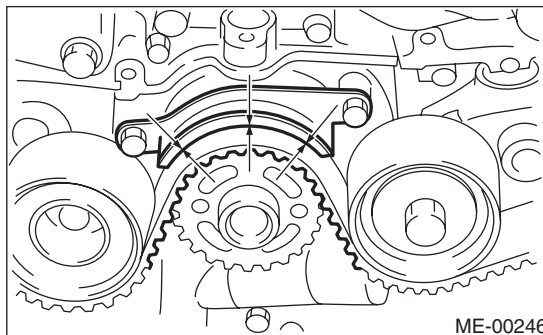

(3) Tighten the bolts mounting the timing belt guide.

Tightening torque:

9.75 N·m (1.0 kgf·m, 7.2 ft·lb)

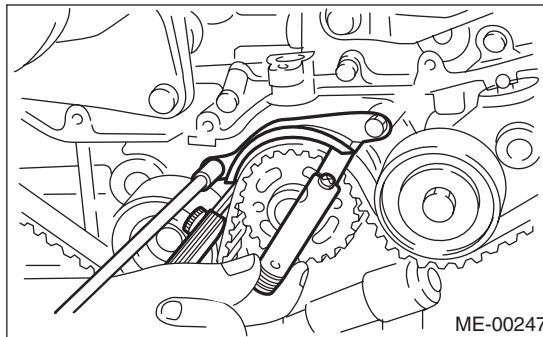

8) Install the timing belt cover.

<Ref. to ME(H4SO)-42, INSTALLATION, Timing Belt Cover.>

9) Install the crank pulley. <Ref. to ME(H4SO)-41, INSTALLATION, Crank Pulley.>

10) Install the V-belts. <Ref. to ME(H4SO)-39, INSTALLATION, V-belt.>

C: INSPECTION

1. TIMING BELT

- 1) Check the timing belt teeth for breaks, cracks or wear. If any fault is found, replace the belt.
- 2) Check the condition of the back surface of belt. If cracks are found, replace the belt.

CAUTION:

- Be careful not to let oil, grease or coolant contact the belt. Remove quickly and thoroughly if this happens.
- Do not bend the timing belt sharply.

In radial diameter h:

60 mm (2.36 in) or more

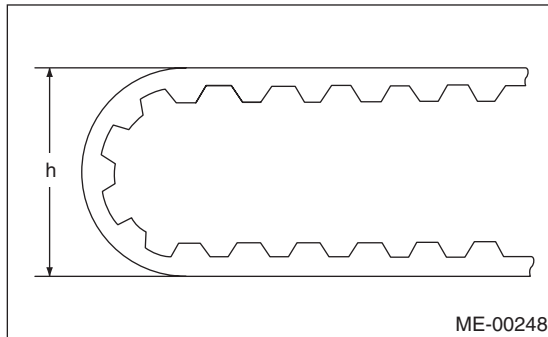

2. AUTOMATIC BELT TENSION ADJUSTER

- 1) Visually check the oil seals for leaks, and rod ends for abnormal wear and scratches. If necessary, replace the automatic belt tension adjuster assembly.

NOTE:

Slight traces of oil at rod's oil seal does not indicate a problem.

- 2) Check that the adjuster rod does not move when a pressure of 294 N (30 kgf, 66 lbf) is applied to it. This is to check adjuster rod stiffness.

- 3) If the adjuster rod is not stiff and moves freely when applying 294 N (30 kgf, 66 lbf), check it using the following procedures:

(1) Slowly press the adjuster rod down to the end surface of cylinder. Repeat this operation two to three times.

(2) With the adjuster rod moved all the way up, apply a pressure of 294 N (30 kgf, 66 lbf) to it. Check the adjuster rod movement.

- (3) If the adjuster rod is not stiff and moves down, replace the automatic belt tension adjuster assembly with a new part.

CAUTION:

- Always use a vertical type pressing tool to move the adjuster rod down.
- Do not use a lateral type vise.
- Push the adjuster rod vertically.
- Press the adjuster rod gradually taking three minutes or more.
- Do not allow press pressure to exceed 9,807 N (1,000 kgf, 2,205 lbf).
- Push in the adjuster rod to the end face of the cylinder. Do not push in the adjuster rod farther than the end face of the cylinder. Doing so may damage the cylinder.

- 4) Measure the amount of protrusion (H) beyond the body end surface. If it is not within specified range, replace with new part.

Amount of rod protrusion H:

5.2 — 6.2 mm (0.205 — 0.244 in)

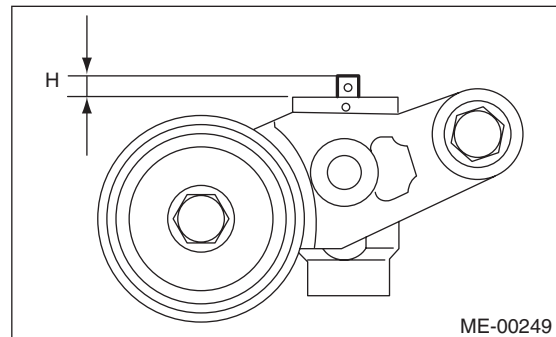

- 5) Check the mating surfaces of timing belt and contact point of adjuster rod for abnormal wear or scratches. Replace the automatic belt tension adjuster assembly if faulty.

- 6) Check the belt tension pulley for smooth rotation. Replace the automatic belt tension adjuster assembly if noise or excessive play occurs.

- 7) Check the belt tension pulley for grease leakage.

3. BELT IDLER

- 1) Check the belt idler for smooth rotation. Replace if noise or excessive play occurs.

- 2) Check the outer contacting surfaces of idler pulley for abnormal wear and scratches.

- 3) Check the belt idler for grease leakage.

16. Cam Sprocket

A: REMOVAL

NOTE:

Perform the work with the engine installed to body when replacing a single part.

- 1) Remove the V-belts. <Ref. to ME(H4SO)-39, REMOVAL, V-belt.>
- 2) Remove the crank pulley. <Ref. to ME(H4SO)-41, REMOVAL, Crank Pulley.>
- 3) Remove the timing belt cover. <Ref. to ME(H4SO)-42, REMOVAL, Timing Belt Cover.>
- 4) Remove the timing belt. <Ref. to ME(H4SO)-43, REMOVAL, Timing Belt.>
- 5) Remove the camshaft position sensor. <Ref. to FU(H4SO)-24, REMOVAL, Camshaft Position Sensor.>
- 6) Remove the cam sprocket No. 2. To lock the camshaft, use the ST.
ST 18231AA010 CAM SPROCKET WRENCH

NOTE:

CAM SPROCKET WRENCH (499207100) can also be used.

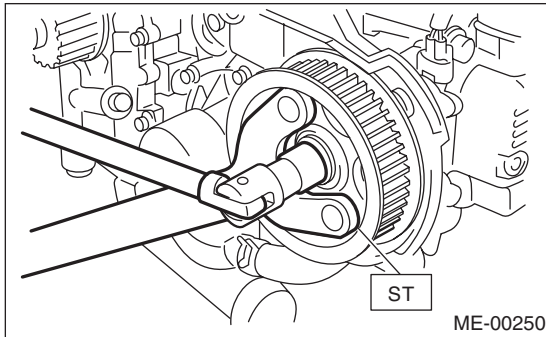

- 7) Remove the cam sprocket No. 1. To lock the camshaft, use the ST.
ST 499207400 CAM SPROCKET WRENCH

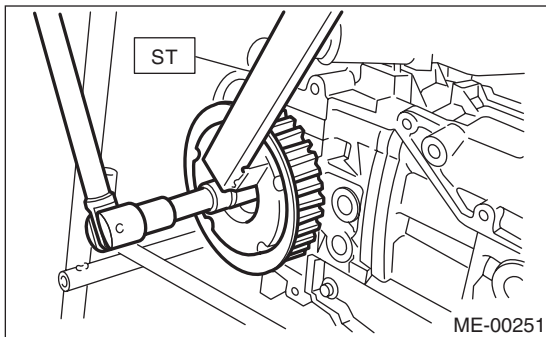

B: INSTALLATION

- 1) Install the cam sprocket No. 1. To lock the camshaft, use the ST.
ST 499207400 CAM SPROCKET WRENCH

Tightening torque:

78 N·m (8.0 kgf-m, 57.9 ft-lb)

NOTE:

Do not confuse left and right side cam sprockets during installation. They should be distinguished by the L or R indication.

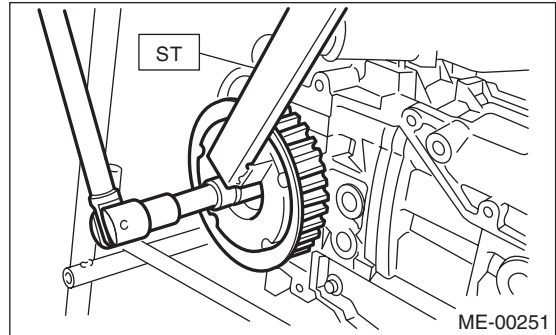

- 2) Install the cam sprocket No. 2. To lock the camshaft, use the ST.
ST 18231AA010 CAM SPROCKET WRENCH

NOTE:

CAM SPROCKET WRENCH (499207100) can also be used.

Tightening torque:

78 N·m (8.0 kgf-m, 57.9 ft-lb)

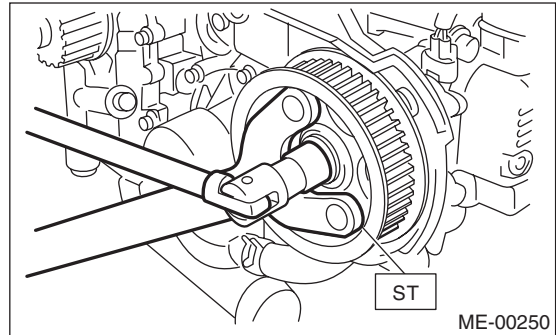

- 3) Install the camshaft position sensor. <Ref. to FU(H4SO)-24, INSTALLATION, Camshaft Position Sensor.>
- 4) Install the timing belt. <Ref. to ME(H4SO)-44, INSTALLATION, Timing Belt.>
- 5) Install the timing belt cover.
<Ref. to ME(H4SO)-42, INSTALLATION, Timing Belt Cover.>
- 6) Install the crank pulley. <Ref. to ME(H4SO)-41, INSTALLATION, Crank Pulley.>
- 7) Install the V-belts. <Ref. to ME(H4SO)-39, INSTALLATION, V-belt.>

C: INSPECTION

- 1) Check the cam sprocket teeth for abnormal wear and scratches.
- 2) Make sure there is no free play between cam sprocket and key.
- 3) Check the cam sprocket protrusion used for sensor for damage and contamination of foreign matter.

17.Crank Sprocket

A: REMOVAL

NOTE:

Perform the work with the engine installed to body when replacing a single part.

- 1) Remove the V-belts. <Ref. to ME(H4SO)-39, REMOVAL, V-belt.>
- 2) Remove the crank pulley. <Ref. to ME(H4SO)-41, REMOVAL, Crank Pulley.>
- 3) Remove the timing belt cover. <Ref. to ME(H4SO)-42, REMOVAL, Timing Belt Cover.>
- 4) Remove the timing belt. <Ref. to ME(H4SO)-43, REMOVAL, Timing Belt.>
- 5) Remove the crank sprocket.

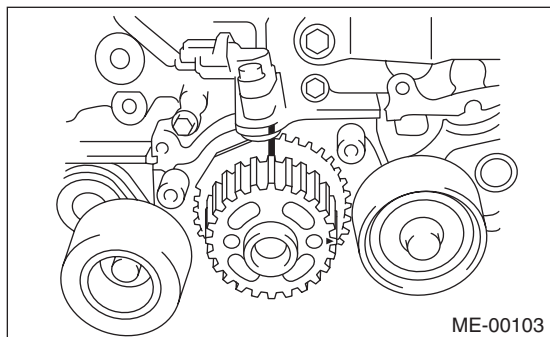

B: INSTALLATION

- 1) Install the crank sprocket.

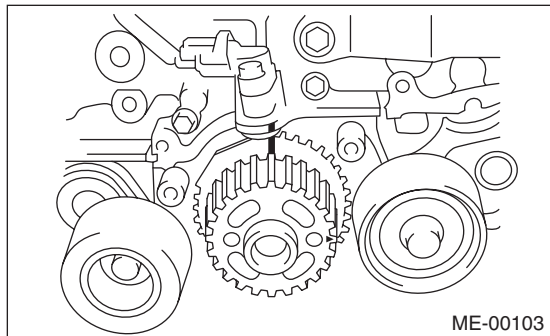

- 2) Install the timing belt. <Ref. to ME(H4SO)-44, INSTALLATION, Timing Belt.>
- 3) Install the timing belt cover. <Ref. to ME(H4SO)-42, INSTALLATION, Timing Belt Cover.>
- 4) Install the crank pulley. <Ref. to ME(H4SO)-41, INSTALLATION, Crank Pulley.>
- 5) Install the V-belts. <Ref. to ME(H4SO)-39, INSTALLATION, V-belt.>

C: INSPECTION

- 1) Check the crank sprocket teeth for abnormal wear and scratches.
- 2) Make sure there is no free play between crank sprocket and key.
- 3) Check the crank sprocket protrusion used for sensor for damage and contamination of foreign matter.

18. Valve Rocker Assembly

A: REMOVAL

NOTE:

Perform the work with the engine installed to body when replacing a single part. Refer to "Valve Clearance" for preparation. <Ref. to ME(H4SO)-29, Valve Clearance.>

- 1) Remove the V-belts. <Ref. to ME(H4SO)-39, REMOVAL, V-belt.>
- 2) Remove the crank pulley. <Ref. to ME(H4SO)-41, REMOVAL, Crank Pulley.>
- 3) Remove the timing belt cover. <Ref. to ME(H4SO)-42, REMOVAL, Timing Belt Cover.>
- 4) Remove the timing belt. <Ref. to ME(H4SO)-43, REMOVAL, Timing Belt.>
- 5) Remove the cam sprocket. <Ref. to ME(H4SO)-48, REMOVAL, Cam Sprocket.>
- 6) Disconnect the PCV hose and remove the rocker cover.
- 7) Remove the valve rocker assembly.

(1) Use the ST to rotate the spring stopper in the direction of the arrow to remove it from adjuster pin.

ST 18258AA000 SPRING INSTALLER

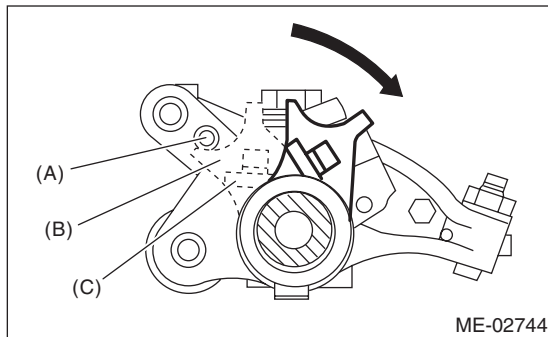
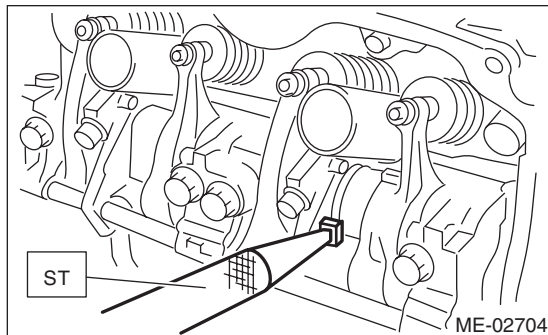

- (A) Adjuster pin
- (B) Spring stopper
- (C) Spring

(2) Remove the bolts (a) through (j) in alphabetical sequence.

NOTE:

Leave two or three threads of bolts (i) and (j) engaged in order to retain the valve rocker assembly.

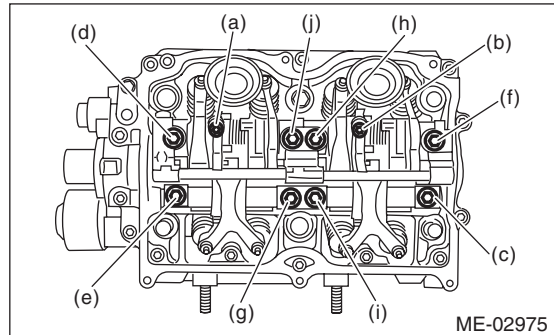

(3) Remove the valve rocker assembly.

NOTE:

Set the ST in the position shown in the drawing to remove the intake valve rocker assembly.

ST 18354AA000 VALVE ROCKER HOLDER

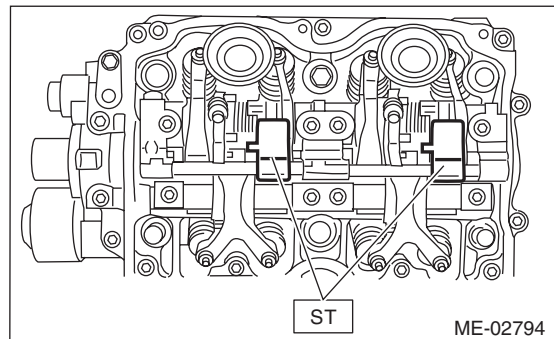

B: INSTALLATION

1) Install the valve rocker assembly.

(1) Temporarily tighten the bolts equally in alphabetical order as shown in the figure.

NOTE:

- Do not temporarily tighten the bolts (i) and (j).
- Set the ST in the position shown in the drawing to mount the intake valve rocker assembly.

ST 18354AA000 VALVE ROCKER HOLDER

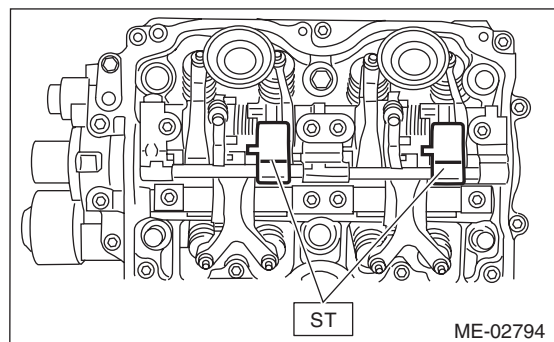

Valve Rocker Assembly

MECHANICAL

(2) Tighten the bolts (a) through (h) to specified torque.

Tightening torque:

25 N·m (2.5 kgf·m, 18.4 ft·lb)

(3) Tighten the bolts (i) through (j) to specified torque.

Tightening torque:

6 N·m (0.6 kgf·m, 4.3 ft·lb)

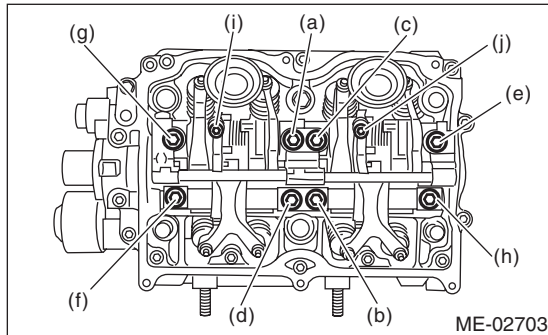

(4) Use the ST to rotate the spring stopper in the direction of the arrow, and hold to the adjuster pin.

ST 18258AA000 SPRING INSTALLER

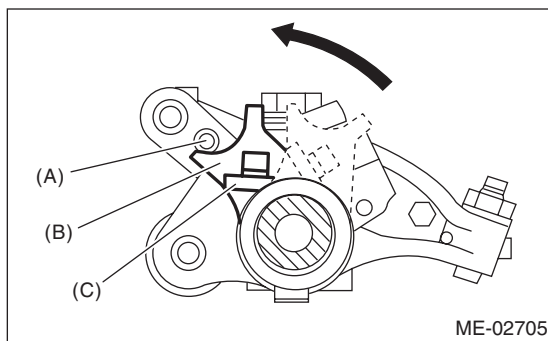
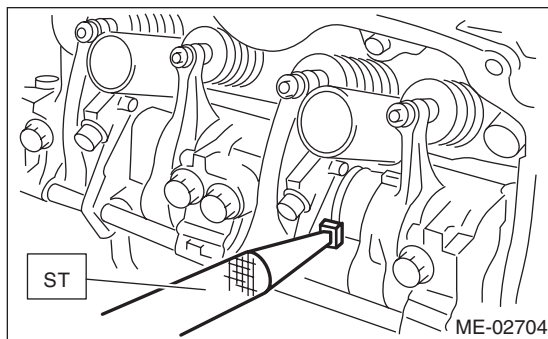

- (A) Adjuster pin
- (B) Spring stopper
- (C) Spring

2) Install the cam sprocket. <Ref. to ME(H4SO)-48, INSTALLATION, Cam Sprocket.>

3) Install the timing belt. <Ref. to ME(H4SO)-44, INSTALLATION, Timing Belt.>

4) Adjust the valve clearance. <Ref. to ME(H4SO)-30, ADJUSTMENT, Valve Clearance.>

5) Install the rocker cover and rocker cover gasket, and then connect PCV hose.

NOTE:

- Use a new rocker cover gasket.
- Tighten the bolts in two stages in alphabetical sequence as shown in figure.

Tightening torque:

1st

6.4 N·m (0.65 kgf·m, 4.7 ft·lb)

2nd (only (a) and (b) are tightened)

6.4 N·m (0.65 kgf·m, 4.7 ft·lb)

- RH side

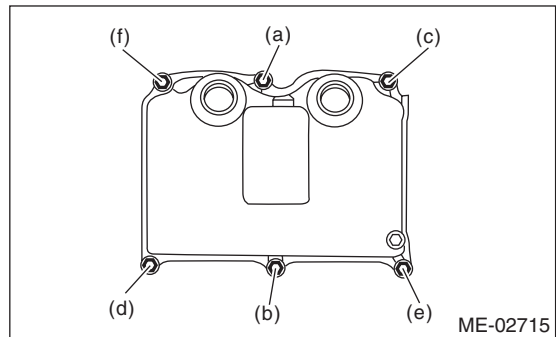

- LH side

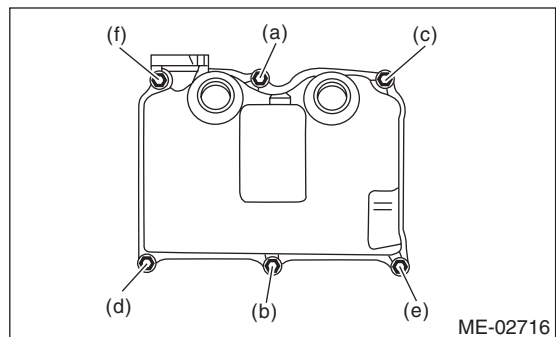

6) Install the timing belt cover.

<Ref. to ME(H4SO)-42, INSTALLATION, Timing Belt Cover.>

7) Install the crank pulley. <Ref. to ME(H4SO)-41, INSTALLATION, Crank Pulley.>

8) Install the V-belts. <Ref. to ME(H4SO)-39, INSTALLATION, V-belt.>

C: DISASSEMBLY

NOTE:

Intake valve rocker assembly cannot be disassembled.

1) Remove the exhaust valve rocker arm from the rocker shaft.

NOTE:

Keep all the removed parts in order for re-installing in their original positions.

2) Remove the nut and adjusting screw from the valve rocker.

D: ASSEMBLY

NOTE:

Intake valve rocker assembly cannot be disassembled.

- 1) Install the adjusting screw and nut to the exhaust valve rocker arm.
- 2) Insert the exhaust valve rocker arm to rocker shaft.

NOTE:

Valve rocker arms, and rocker shaft have identification marks. Make sure the parts with same markings are properly assembled.

E: INSPECTION

1. INTAKE VALVE ROCKER ASSEMBLY

- 1) If the roller or valve contact surface of valve rocker arm is worn or dented excessively, replace the valve rocker assembly.
- 2) Check the valve rocker arm roller for smooth rotation. If not, replace the valve rocker assembly.

2. EXHAUST VALVE ROCKER ASSEMBLY

- 1) Measure the inner diameter of valve rocker arm and outer diameter of valve rocker shaft, and confirm the difference (oil clearance) between the two values.

Clearance between arm and shaft:

Standard:

0.020 — 0.054 mm (0.0008 — 0.0021 in)

Service limit:

0.10 mm (0.0039 in)

- 2) If the oil clearance exceeds the limit, replace the valve rocker arm or shaft, whichever shows the greater amount of wear.

Rocker arm inside diameter:

22.020 — 22.041 mm (0.8669 — 0.8678 in)

Rocker shaft diameter:

21.987 — 22.000 mm (0.8656 — 0.8661 in)

- 3) If the cam or valve contact surface of valve rocker arm is worn or dented excessively, replace the valve rocker arm.
- 4) Check the valve rocker arm roller for smooth rotation. If not, replace the valve rocker arm.

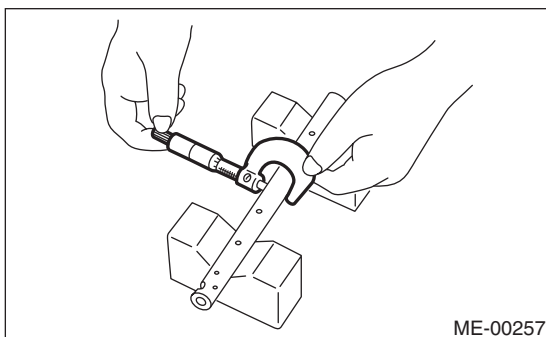
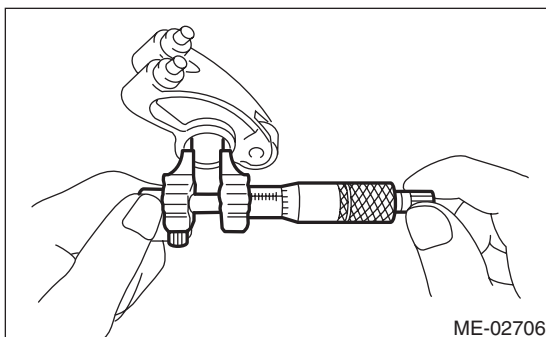

19. Camshaft

A: REMOVAL

NOTE:

Perform the work with the engine installed to body when replacing a single part. Refer to "Valve Clearance" for preparation. <Ref. to ME(H4SO)-29, Valve Clearance.>

- 1) Remove the V-belts. <Ref. to ME(H4SO)-39, REMOVAL, V-belt.>
- 2) Remove the crank pulley. <Ref. to ME(H4SO)-41, REMOVAL, Crank Pulley.>
- 3) Remove the timing belt cover. <Ref. to ME(H4SO)-42, REMOVAL, Timing Belt Cover.>
- 4) Remove the timing belt. <Ref. to ME(H4SO)-43, REMOVAL, Timing Belt.>
- 5) Remove the cam sprocket. <Ref. to ME(H4SO)-48, REMOVAL, Cam Sprocket.>
- 6) Remove the timing belt cover No. 2 (LH).
- 7) Remove the timing belt cover No. 2 (RH).

NOTE:

Do not damage or lose the seal rubber when removing the timing belt covers.

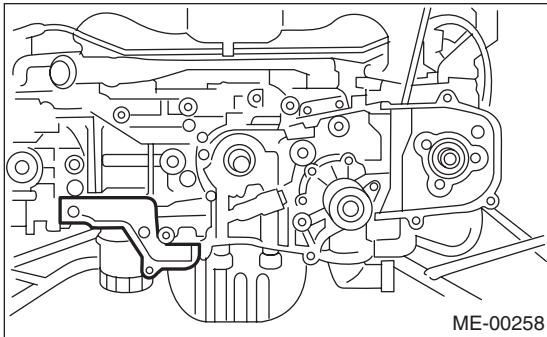

- 8) Remove the tensioner bracket.

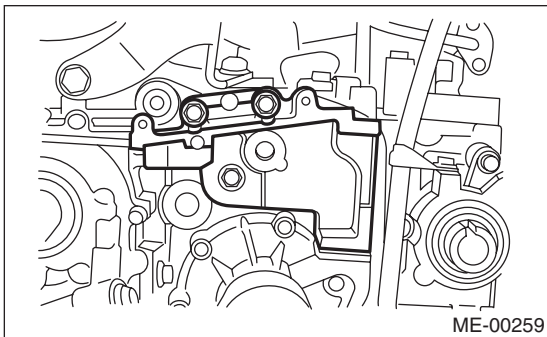

- 9) Remove the camshaft position sensor support. (LH side only)
- 10) Remove the oil level gauge guide. (LH side only)
- 11) Remove the valve rocker assembly. <Ref. to ME(H4SO)-51, REMOVAL, Valve Rocker Assembly.>

- 12) Remove the camshaft cap.
 - (1) Remove the bolts (a) and (b) in alphabetical sequence.

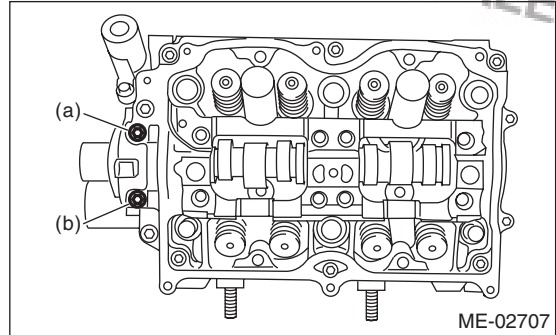

- (2) Equally loosen the bolts (c) through (j) all the way in alphabetical sequence.

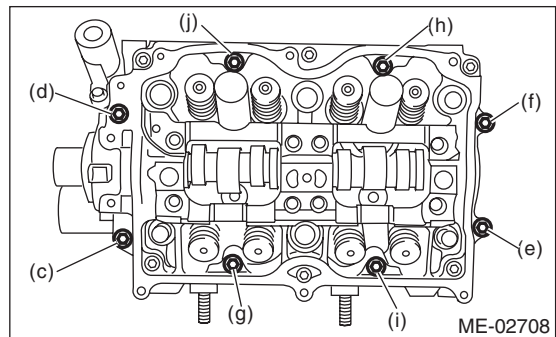

- (3) Remove the bolts (k) through (p) in alphabetical sequence using ST.

ST 499497000 TORX PLUS®

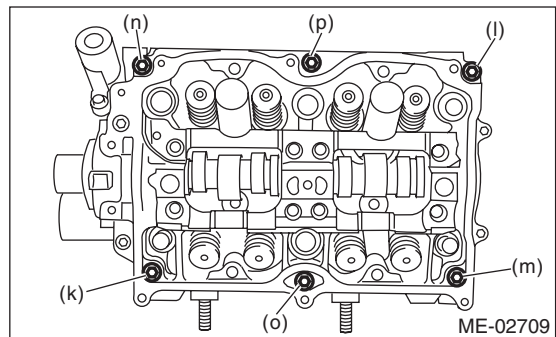

- (4) Remove the camshaft cap.
- 13) Remove the camshaft.
- 14) Remove the oil seal.
- 15) Remove the plug from rear side of camshaft.

CAUTION:

- Do not remove the oil seal unless necessary.
- Do not scratch the journal surface when removing the oil seal.

B: INSTALLATION

- 1) Apply a thin coat of engine oil to camshaft journals, and install the camshaft.
- 2) Install the camshaft cap.
 - (1) Apply liquid gasket to the mating surfaces of camshaft cap.

Liquid gasket:
THREE BOND 1280B (Part No. K0877YA018)

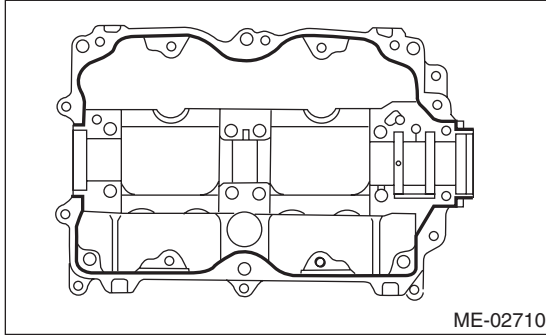

NOTE:

- Apply a coat of liquid gasket of 3 mm (0.12 in) in diameter (A) along the edge (B) of camshaft cap (C) mating surface.
- Install within 5 min. after applying liquid gasket.

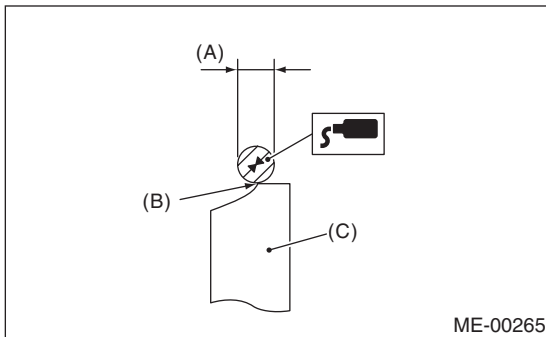

- (2) Temporarily tighten the bolts (a) through (d) in alphabetical sequence.

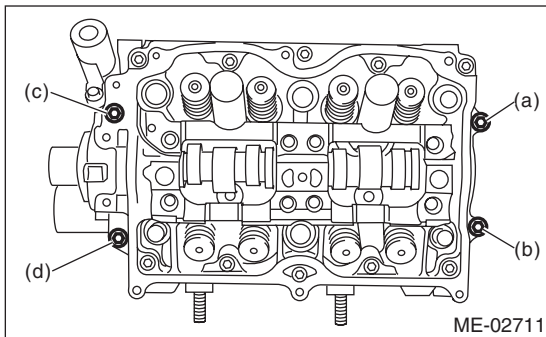

- (3) Install the valve rocker assembly. <Ref. to ME(H4SO)-51, INSTALLATION, Valve Rocker Assembly.>

- (4) Tighten the TORX® bolts (e) through (j) in alphabetical sequence using the ST. ST 499497000 TORX PLUS®

Tightening torque:
18 N·m (1.8 kgf-m, 13.3 ft-lb)

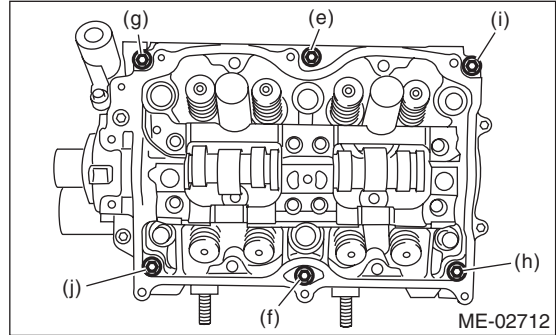

- (5) Tighten the bolts (k) through (r) in alphabetical sequence.

Tightening torque:
9.75 N·m (1.0 kgf-m, 7.2 ft-lb)

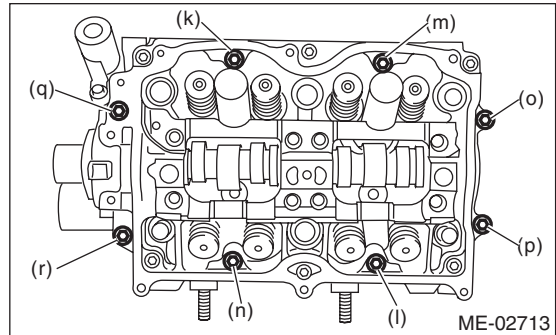

- (6) Tighten the bolts (s) and (t) in alphabetical sequence.

NOTE:

- Use a new seal washer.
- Install and tighten the seal washer.

Tightening torque:
9.75 N·m (1.0 kgf-m, 7.2 ft-lb)

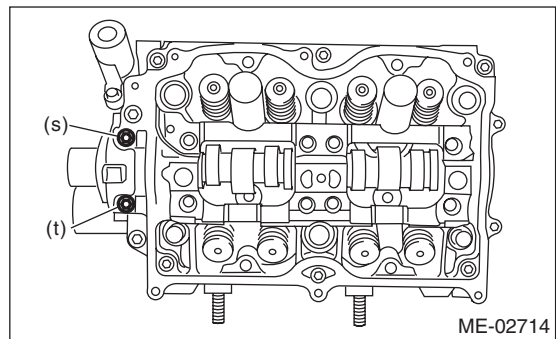

Camshaft

MECHANICAL

3) Apply a coat of engine oil to oil seal periphery and oil seal lips and install the oil seal (A) on camshaft using ST1 and ST2.

NOTE:

Use a new oil seal.

ST1 499597000 OIL SEAL GUIDE

ST2 499587500 OIL SEAL INSTALLER

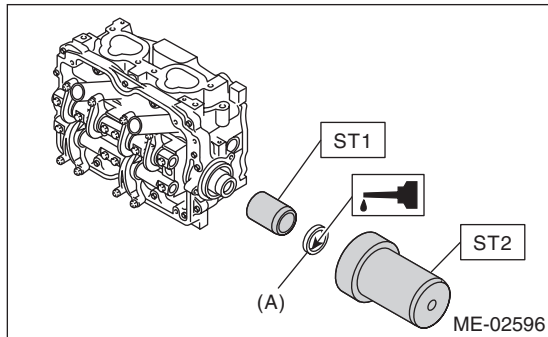

4) Install the plug (A) using ST.

ST 499587700 CAMSHAFT OIL SEAL INSTALLER

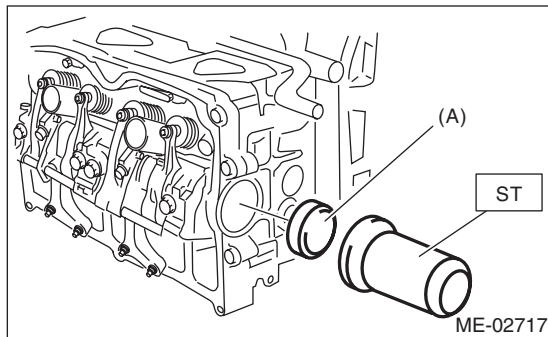

5) Adjust the valve clearance. <Ref. to ME(H4SO)-30, ADJUSTMENT, Valve Clearance.>

6) Install the rocker cover and rocker cover gasket, and then connect PCV hose.

NOTE:

- Use a new rocker cover gasket.
- Tighten the bolts in two stages in alphabetical sequence as shown in figure.

Tightening torque:

1st

6.4 N·m (0.65 kgf-m, 4.7 ft-lb)

2nd (only (a) and (b) are tightened)

6.4 N·m (0.65 kgf-m, 4.7 ft-lb)

• RH side

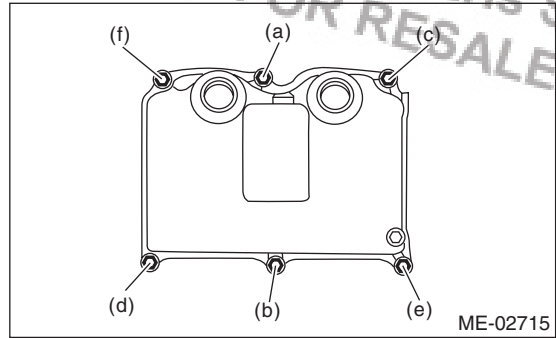

• LH side

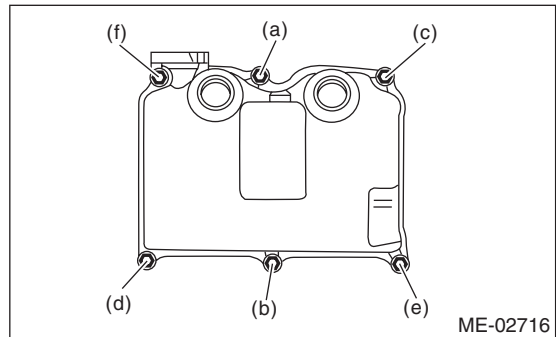

7) Install the oil level gauge guide. (LH side)

8) Install the camshaft position sensor support. (LH side)

9) Install the tensioner bracket.

Tightening torque:

24.5 N·m (2.5 kgf-m, 18.1 ft-lb)

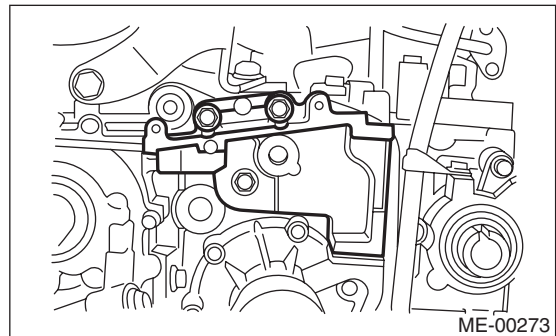

10) Install the timing belt cover No. 2 (RH).

Tightening torque:

5 N·m (0.5 kgf-m, 3.6 ft-lb)

11) Install the timing belt cover No. 2 (LH).

Tightening torque:

5 N·m (0.5 kgf·m, 3.6 ft·lb)

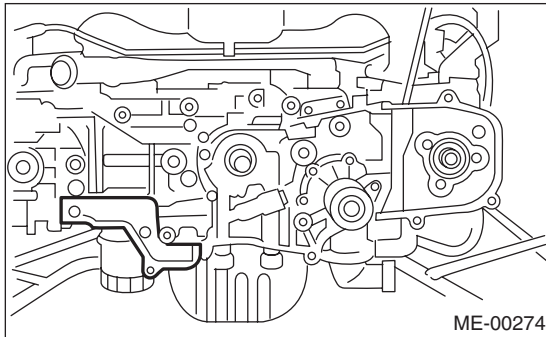

12) Install the cam sprocket. <Ref. to ME(H4SO)-48, INSTALLATION, Cam Sprocket.>

13) Install the timing belt. <Ref. to ME(H4SO)-44, INSTALLATION, Timing Belt.>

14) Install the timing belt cover. <Ref. to ME(H4SO)-42, INSTALLATION, Timing Belt Cover.>

15) Install the crank pulley. <Ref. to ME(H4SO)-41, INSTALLATION, Crank Pulley.>

16) Install the V-belts. <Ref. to ME(H4SO)-39, INSTALLATION, V-belt.>

C: INSPECTION

1) Measure the bend, and repair or replace if necessary.

Service limit:

0.025 mm (0.0098 in)

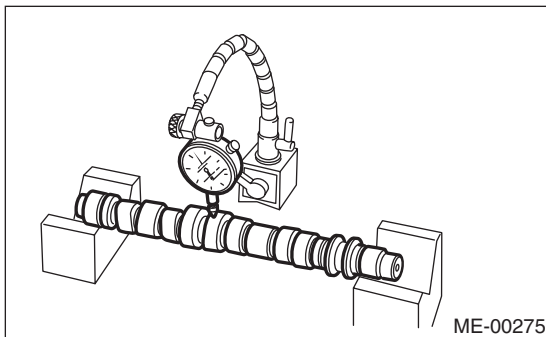

2) Check the journal for damage and wear. Replace if faulty.

3) Measure the outer diameter of camshaft journal and inner diameter of cylinder head journal, and confirm the difference (oil clearance) between the two values. If the oil clearance is not within the standard, replace the camshaft or cylinder head as necessary.

Unit: mm (in)		
Oil clearance	Standard	0.055 — 0.090 (0.0022 — 0.0035)
	Limit	0.10 (0.0039)
Camshaft journal O.D.		31.928 — 31.945 (1.2570 — 1.2577)
Journal hole I.D.		32.000 — 32.018 (1.2598 — 1.2605)

4) Check the cam face condition, and remove the minor faults by grinding with oil stone. Measure the cam height H. If it is not within the standard, replace the part.

Cam height H:

Part		Unit: mm (in)	
Intake	Constant	Standard	40.075 — 40.175 (1.5778 — 1.5817)
		Limit	39.975 (1.5738)
	Low speed	Standard	35.182 — 35.282 (1.3851 — 1.3891)
		Limit	35.082 (1.3812)
	High speed	Standard	40.315 — 40.415 (1.5872 — 1.5911)
		Limit	40.215 (1.5833)
Exhaust		Standard	40.149 — 40.249 (1.5807 — 1.5846)
		Limit	40.049 (1.5767)

Cam base circle diameter A:

Intake: 34.00 mm (1.3386 in)

Exhaust: 34.00 mm (1.3386 in)

Base circle step of adjacent intake cams (low speed and high speed):

0.03 mm (0.001 in) or less

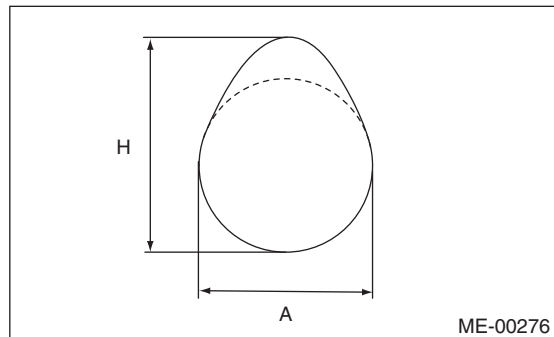

5) Measure the thrust clearance of camshaft with setting the dial gauge at end of camshaft. If the thrust clearance is not within the limit, replace the camshaft caps and cylinder head as a set. If necessary, replace the camshaft.

Standard:

0.030 — 0.090 mm (0.0012 — 0.0035 in)

Service limit:

0.10 mm (0.0039 in)

20. Cylinder Head

A: REMOVAL

NOTE:

Perform the work with the engine installed to body when replacing a single part. Refer to "Valve Clearance" for preparation. <Ref. to ME(H4SO)-29, Valve Clearance.>

- 1) Remove the V-belts. <Ref. to ME(H4SO)-39, REMOVAL, V-belt.>
- 2) Remove the crank pulley. <Ref. to ME(H4SO)-41, REMOVAL, Crank Pulley.>
- 3) Remove the timing belt cover. <Ref. to ME(H4SO)-42, REMOVAL, Timing Belt Cover.>
- 4) Remove the timing belt. <Ref. to ME(H4SO)-43, REMOVAL, Timing Belt.>
- 5) Remove the cam sprocket. <Ref. to ME(H4SO)-48, REMOVAL, Cam Sprocket.>
- 6) Remove the intake manifold. <Ref. to FU(H4SO)-13, REMOVAL, Intake Manifold.>
- 7) Remove the bolt which installs the A/C compressor bracket on cylinder head.
- 8) Remove the valve rocker assembly. <Ref. to ME(H4SO)-51, REMOVAL, Valve Rocker Assembly.>
- 9) Remove the camshaft. <Ref. to ME(H4SO)-54, REMOVAL, Camshaft.>
- 10) Remove the cylinder head bolts in alphabetical sequence as shown in the figure.

NOTE:

Leave bolts (a) and (c) engaged by three or four threads to prevent the cylinder head from falling.

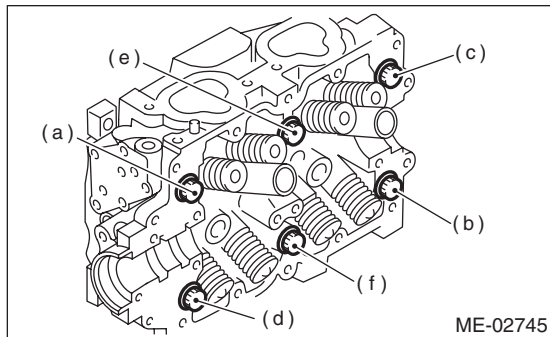

- 11) While tapping the cylinder head with a plastic hammer, separate it from cylinder block.
- 12) Remove the bolts (a) and (c) to remove cylinder head.

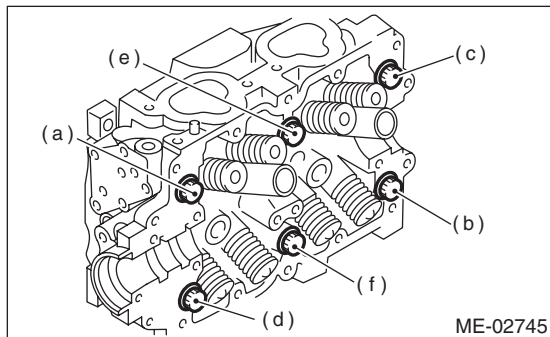

- 13) Remove the cylinder head gasket.

CAUTION:

Be careful not to scratch the mating surface of cylinder head and cylinder block.

- 14) Similarly, remove the right side cylinder head.

B: INSTALLATION

- 1) Install the cylinder head and gaskets on cylinder block.

CAUTION:

Be careful not to scratch the mating surface of cylinder block and cylinder head.

NOTE:

Use a new gasket.

- 2) Tighten the cylinder head bolts.
 - (1) Apply a thin coat of engine oil to washer and bolt thread.
 - (2) Tighten all bolts to 29 N·m (3.0 kgf-m, 21.4 ft-lb) in alphabetical order. Then tighten all bolts to 69 N·m (7.0 kgf-m, 50.9 ft-lb) in alphabetical sequence.
 - (3) Loosen all the bolts by 180° in reverse order of installation, and loosen again by 180° in the same order.
 - (4) Tighten all bolts to 42 N·m (4.3 kgf-m, 31 ft-lb) in alphabetical order.
 - (5) Tighten all bolts by 80 to 90° in alphabetical sequence.
 - (6) Tighten all bolts by 40 to 45° in alphabetical sequence.

CAUTION:

The tightening angle of the bolt should not exceed 45°.

- (7) Further tighten the bolts (a) and (b) by 40 — 45°.

CAUTION:

Make sure the total "re-tightening angle" of the step (6) and (7) does not exceed 90°.

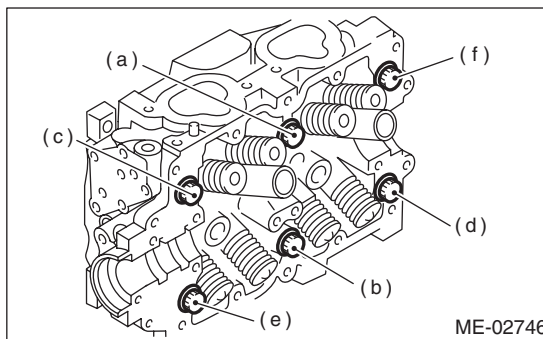

- 3) Install the camshaft. <Ref. to ME(H4SO)-55, INSTALLATION, Camshaft.>
- 4) Install the valve rocker assembly. <Ref. to ME(H4SO)-51, INSTALLATION, Valve Rocker Assembly.>

- 5) Install the A/C compressor bracket on cylinder head.
- 6) Install the intake manifold.
<Ref. to FU(H4SO)-15, INSTALLATION, Intake Manifold.>
- 7) Install the cam sprocket. <Ref. to ME(H4SO)-48, INSTALLATION, Cam Sprocket.>
- 8) Install the timing belt. <Ref. to ME(H4SO)-44, INSTALLATION, Timing Belt.>
- 9) Adjust the valve clearance. <Ref. to ME(H4SO)-30, ADJUSTMENT, Valve Clearance.>
- 10) Install the rocker cover and rocker cover gasket, and then connect PCV hose.

NOTE:

Use a new rocker cover gasket.

- 11) Install the timing belt cover.
<Ref. to ME(H4SO)-42, INSTALLATION, Timing Belt Cover.>
- 12) Install the crank pulley. <Ref. to ME(H4SO)-41, INSTALLATION, Crank Pulley.>
- 13) Install the V-belts. <Ref. to ME(H4SO)-39, INSTALLATION, V-belt.>

C: DISASSEMBLY

- 1) Place the cylinder head on the ST.
ST 498267800 CYLINDER HEAD TABLE
- 2) Set the ST on valve spring. Compress the valve spring and remove the valve spring retainer key. Remove each valve and valve spring.

NOTE:

- Keep all the removed parts in order for re-installing in their original positions.
- Mark each valve to prevent confusion.
- Pay careful attention not to damage the lips of intake valve oil seals and exhaust valve oil seals.

ST 499718000 VALVE SPRING REMOVER

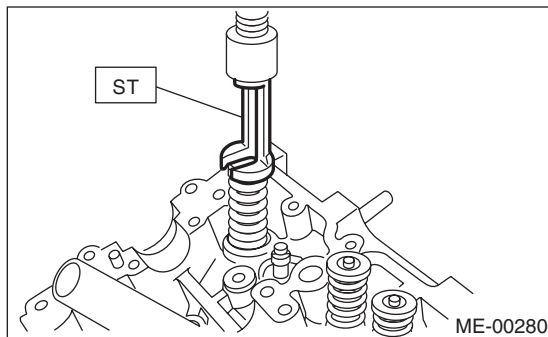

D: ASSEMBLY

Brought to you by Eris Studios
NOT FOR RESALE

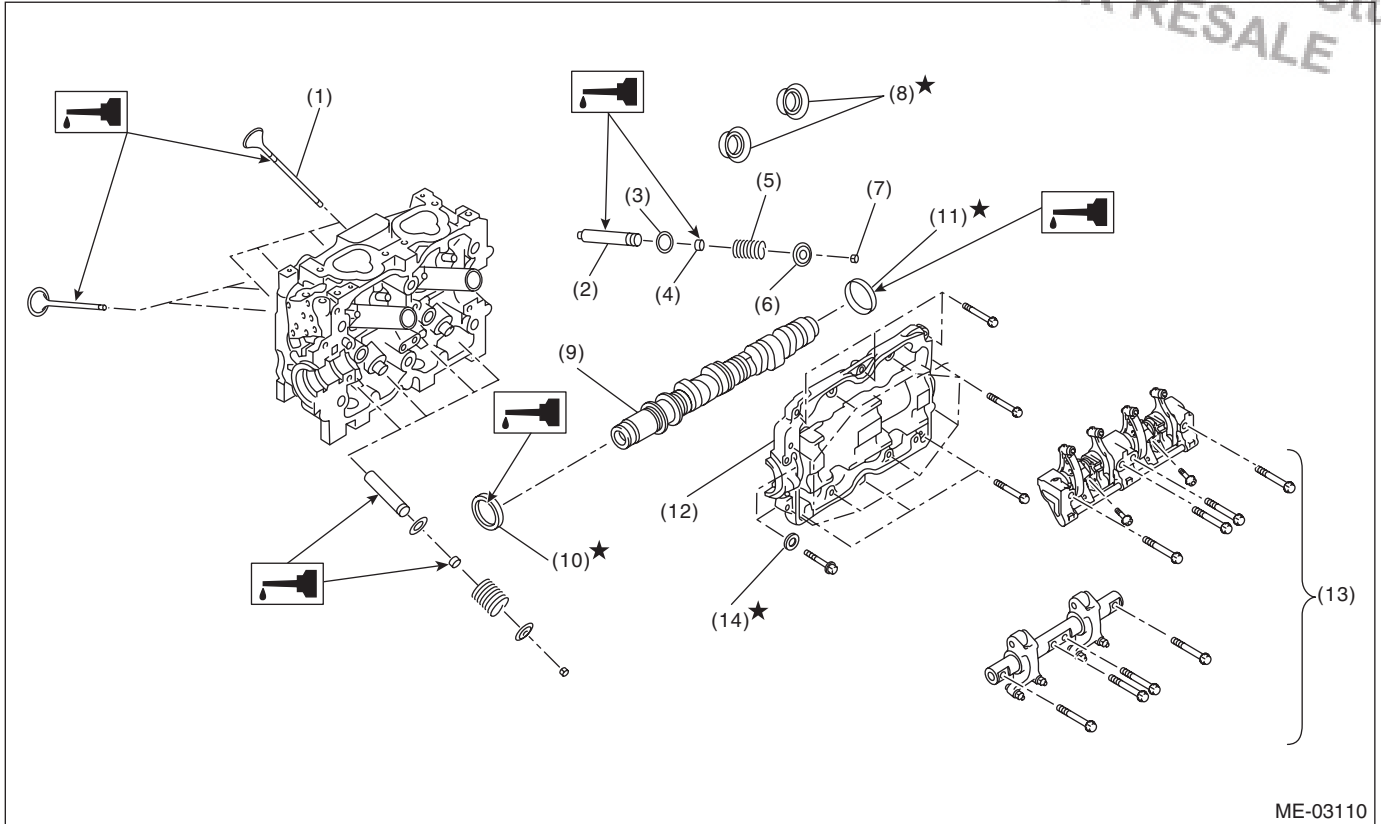

ME-03110

- | | | |
|-----------------------|-----------------------|------------------------|
| (1) Valve | (6) Retainer | (11) Plug |
| (2) Valve guide | (7) Retainer key | (12) Camshaft cap |
| (3) Valve spring seat | (8) Spark plug gasket | (13) Valve rocker ASSY |
| (4) Oil seal | (9) Camshaft | (14) Seal washer |
| (5) Valve spring | (10) Oil seal | |

- 1) Installation of valve spring and valve:
 (1) Place the cylinder head on the ST.
 ST 498267800 CYLINDER HEAD TABLE
 (2) Coat the stem of each valve with engine oil and insert the valve into the valve guide.

NOTE:

When inserting the valve into valve guide, use special care not to damage the oil seal lip.

- (3) Install the valve spring and retainer.

NOTE:

Be sure to install the valve spring with its close-coiled end facing the seat on cylinder head.

- (4) Set the ST on valve spring.

ST 499718000 VALVE SPRING REMOVER

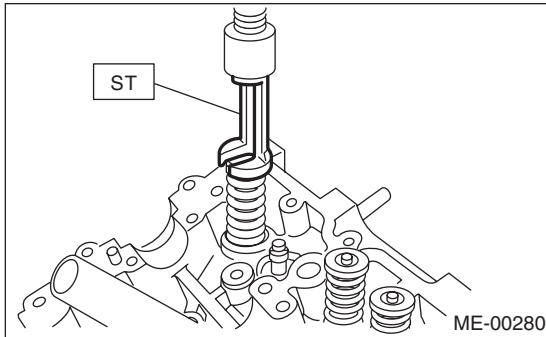

- (5) Compress the valve spring and fit the valve spring retainer and valve spring retainer key.

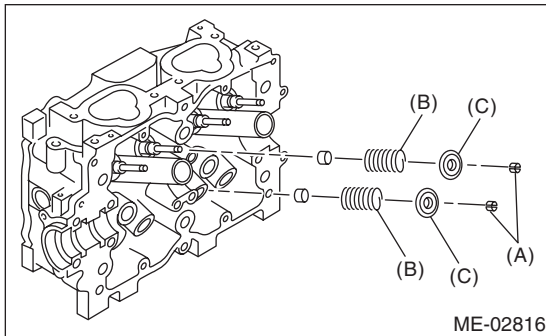

- (A) Retainer key
- (B) Valve spring
- (C) Valve spring retainer

- (6) After installing, tap the valve spring retainers lightly with a plastic hammer for better seating.

E: INSPECTION

1. CYLINDER HEAD

1) Check for cracks or damage. Use liquid penetrant tester on the important sections to check for fissures. Check that there are no marks of gas leaking or water leaking on gasket installing surface.

2) Place the cylinder head on the ST.

ST 498267800 CYLINDER HEAD TABLE

3) Measure the warping of the cylinder head surface that mates with the cylinder block using a straight edge and thickness gauge.

If the warping exceeds the limit, correct the surface by grinding it with a surface grinder.

Warping limit:

0.035 mm (0.0014 in)

Grinding limit:

0.1 mm (0.004 in)

Standard height of cylinder head:

97.5 mm (3.84 in)

NOTE:

Uneven torque for the cylinder head bolts can cause warping. When reassembling, pay special attention to the torque so as to tighten evenly.

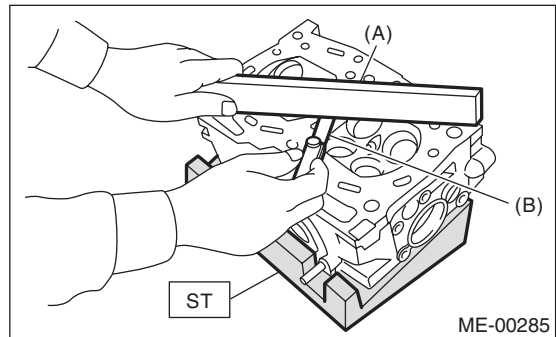

- (A) Straight edge
- (B) Thickness gauge

2. VALVE SEAT

Inspect the intake and exhaust valve seats, and correct the contact surfaces with a valve seat cutter if they are defective or when valve guides are replaced.

Valve seat width *W*:

Standard

Intake (A)

0.8 — 1.4 mm (0.03 — 0.055 in)

Exhaust (B)

1.2 — 1.8 mm (0.047 — 0.071 in)

Limit

Intake (A)

1.7 mm (0.067 in)

Exhaust (B)

2.2 mm (0.087 in)

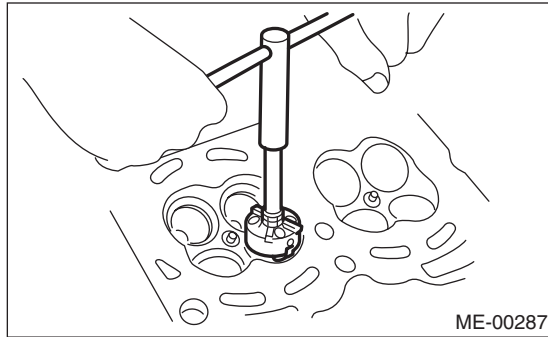
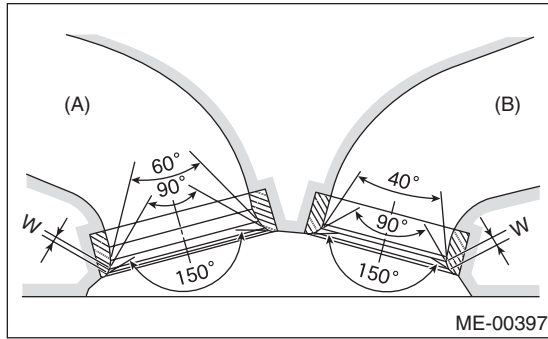

3. VALVE GUIDE

1) Check the clearance between valve guide and stem. The clearance can be checked by measuring respectively the outer diameter of valve stem with a micrometer and the inner diameter of valve guide with a caliper gauge.

Clearance between the valve guide and valve stem:

Standard

Intake

0.035 — 0.062 mm (0.0014 — 0.0024 in)

Exhaust

0.040 — 0.067 mm (0.0016 — 0.0026 in)

Limit

0.15 mm (0.059 in)

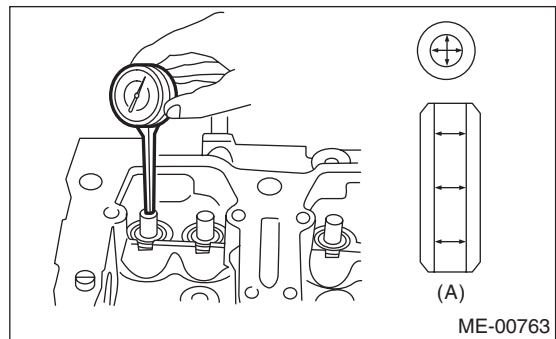

(A) Valve guide

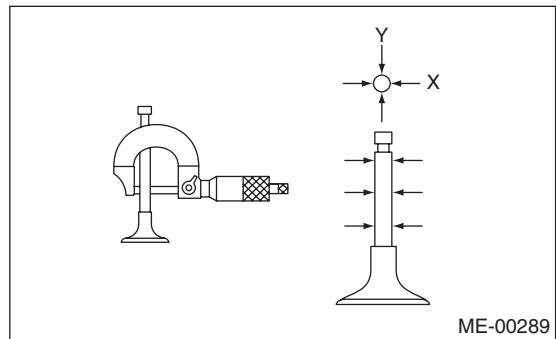

2) If the clearance between valve guide and stem is not within the limit, replace the valve guide or valve itself whichever shows greater amount of wear. See the following procedure for valve guide replacement.

Valve guide inner diameter:

6.000 — 6.012 mm (0.2362 — 0.2367 in)

Valve stem outer diameters:

Intake

5.950 — 5.965 mm (0.2343 — 0.2348 in)

Exhaust

5.945 — 5.960 mm (0.2341 — 0.2346 in)

(1) Place the cylinder head on ST1 with the combustion chamber upward so that valve guides fit the holes in ST1.

(2) Insert the ST2 into valve guide and press it down to remove the valve guide.

ST1 498267800 CYLINDER HEAD TABLE
ST2 499767200 VALVE GUIDE REMOVER

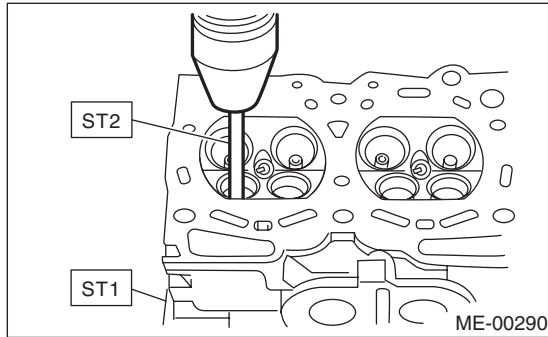

(3) Turn the cylinder head upside down and place the ST as shown in the figure.

Intake side

ST 499767700 VALVE GUIDE ADJUSTER

Exhaust side

ST 499767800 VALVE GUIDE ADJUSTER

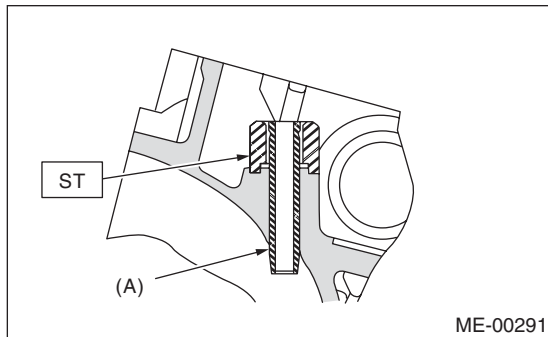

(A) Valve guide

(4) Before installing a new valve guide, make sure that neither scratches nor damages exist on the inner surface of valve guide holes in cylinder head.

(5) Put a new valve guide, coated with sufficient oil, in cylinder, and insert the ST1 into valve guide. Press in until the valve guide upper end is flush with the upper surface of ST2.

ST1 499767200 VALVE GUIDE REMOVER
Intake side
ST2 499767700 VALVE GUIDE ADJUSTER
Exhaust side
ST2 499767800 VALVE GUIDE ADJUSTER

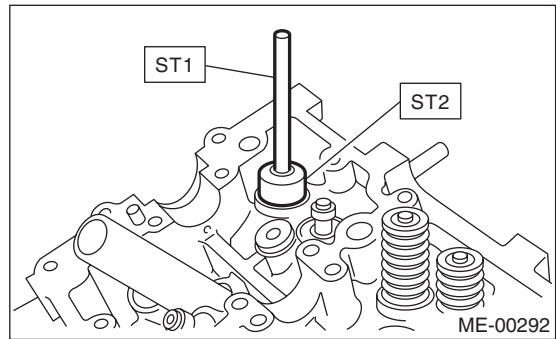

(6) Check the valve guide protrusion.

Valve guide protrusion L:

Intake

20.0 — 21.0 mm (0.787 — 0.827 in)

Exhaust

16.5 — 17.5 mm (0.650 — 0.689 in)

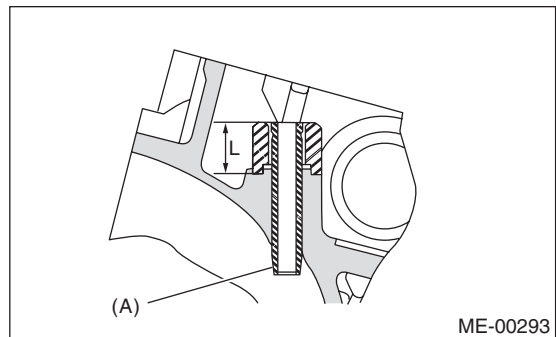

(A) Valve guide

(7) Ream the inside of valve guide using ST. Put the ST in valve guide, and rotate the ST slowly clockwise while pushing it lightly. Bring the ST back while rotating it clockwise.

NOTE:

- Apply engine oil to the ST when reaming.
- If the inner surface of valve guide is damaged, the edge of ST should be slightly ground with oil stone.
- If the inner surface of valve guide becomes lustrous and the ST does not chip, use a new ST or remedy the ST.

ST 499767400 VALVE GUIDE REAMER

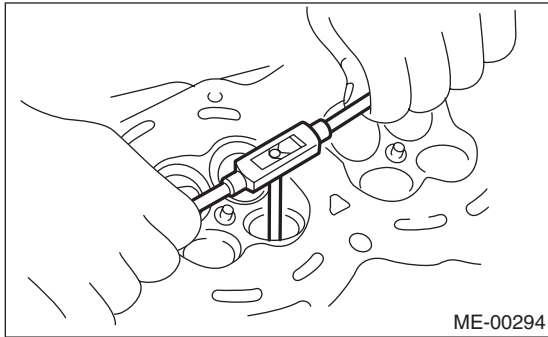

- (8) After reaming, clean the valve guide to remove chips.
 (9) Recheck the contact condition between valve and valve seat after replacing the valve guide.

4. INTAKE AND EXHAUST VALVE

1) Inspect the flange and stem of valve, and replace if damaged, worn, or deformed, or if "H" is outside of the limit.

H:

Intake

Standard: 0.8 — 1.2 mm (0.03 — 0.047 in)
Limit: 0.6 mm (0.024 in)

Exhaust

Standard: 1.0 — 1.4 mm (0.039 — 0.055 in)
Limit: 0.6 mm (0.024 in)

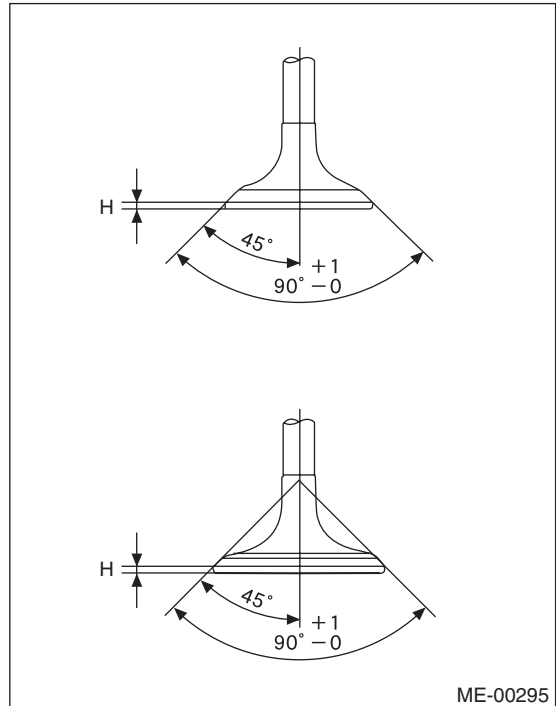

2) Apply a small amount of grinding compound on the seat surface, and lap the valve and seat surface. <Ref. to ME(H4SO)-62, VALVE SEAT, INSPECTION, Cylinder Head.> Install a new intake valve oil seal after lapping.

NOTE:

It is possible to differentiate between the intake valve and the exhaust valve by their overall length.

Valve overall length:

Intake

120.6 mm (4.75 in)

Exhaust

121.7 mm (4.79 in)

5. VALVE SPRING

- 1) Check the valve springs for damage, free length, and tension. Replace the valve spring if it is not within the standard value presented in the table.
- 2) To measure the squareness of the valve spring, stand the spring on a surface plate and measure its deflection at the top of spring using a try square.

Free length	mm (in)	55.2 (2.173)
Squareness		2.5°, 2.4 mm (0.094 in) or less
Tension/spring height	Set	235.3 — 270.7 (24 — 27.6, 52.9 — 60.8)/45.0 (1.772)
	Lift	578.9 — 639.9 (59.1 — 65.3, 130.3 — 143.9)/34.7 (1.366)
	N (kgf, lbf)/mm (in)	

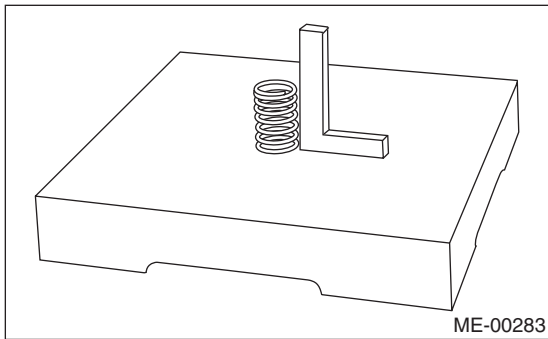

6. INTAKE AND EXHAUST VALVE OIL SEAL

For the following, remove the oil seal from the valve guide and replace it with a new part.

- When the lip is damaged.
 - When the spring is out of the specified position.
 - When readjusting the surfaces of valve and valve seat.
 - When replacing the intake valve guide.
- 1) Place the cylinder head on ST1.
 - 2) Using the ST2, press-fit the oil seal.

NOTE:

- Apply engine oil to oil seal before press-fitting.
- When press-fitting the oil seal, do not use a hammer or strike in.
- The intake valve oil seal and exhaust valve oil seal can be distinguished by colors.

Color of rubber part:

Intake [Gray]

Exhaust [Green]

- ST1 498267800 CYLINDER HEAD TABLE
- ST2 498857100 VALVE OIL SEAL GUIDE

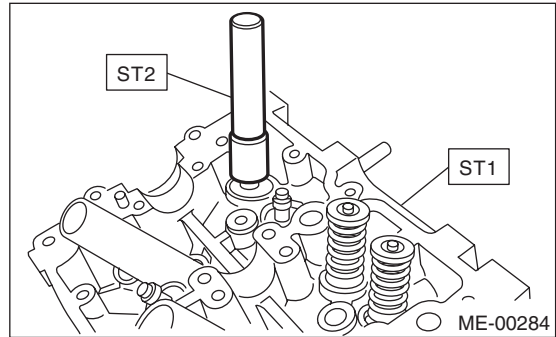

21. Cylinder Block

A: REMOVAL

NOTE:

Before conducting this procedure, drain the engine oil completely.

- 1) Remove the intake manifold. <Ref. to FU(H4SO)-13, REMOVAL, Intake Manifold.>
- 2) Remove the V-belts. <Ref. to ME(H4SO)-39, REMOVAL, V-belt.>
- 3) Remove the crank pulley. <Ref. to ME(H4SO)-41, REMOVAL, Crank Pulley.>
- 4) Remove the timing belt cover. <Ref. to ME(H4SO)-42, REMOVAL, Timing Belt Cover.>
- 5) Remove the timing belt. <Ref. to ME(H4SO)-43, REMOVAL, Timing Belt.>
- 6) Remove the cam sprocket. <Ref. to ME(H4SO)-48, REMOVAL, Cam Sprocket.>
- 7) Remove the crank sprocket. <Ref. to ME(H4SO)-50, REMOVAL, Crank Sprocket.>
- 8) Remove the generator and A/C compressor together with their brackets.
- 9) Remove the rocker cover.
- 10) Remove the cylinder head bolts in alphabetical order shown in the figure.

NOTE:

Leave bolts (a) and (d) engaged by three or four threads to prevent the cylinder head from falling.

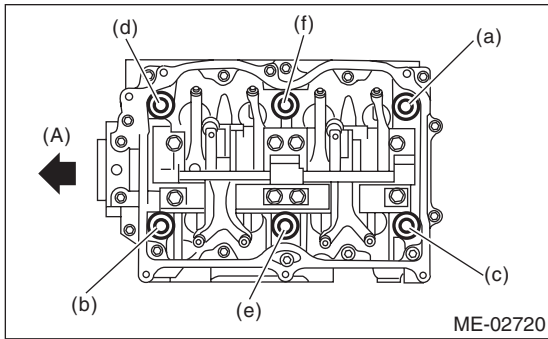

(A) Front side

- 11) While tapping the cylinder head with a plastic hammer, separate it from cylinder block.

- 12) Remove the bolts (a) and (d) to remove cylinder head.

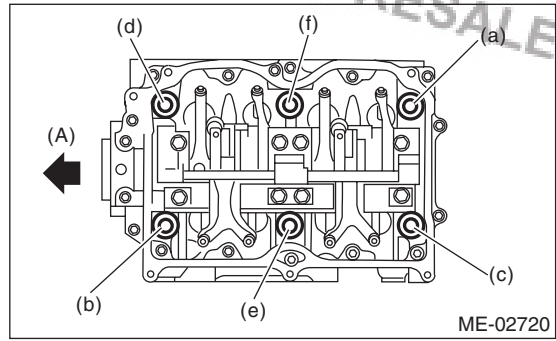

(A) Front side

- 13) Remove the cylinder head gasket.

NOTE:

Do not scratch the mating surface of cylinder head and cylinder block.

- 14) Similarly, remove the right side cylinder head.
- 15) Remove the clutch cover. (MT model)
- 16) Remove the flywheel (MT model) or drive plate (AT model).

Using the ST, lock the crankshaft.

ST 498497100 CRANKSHAFT STOPPER

- MT model

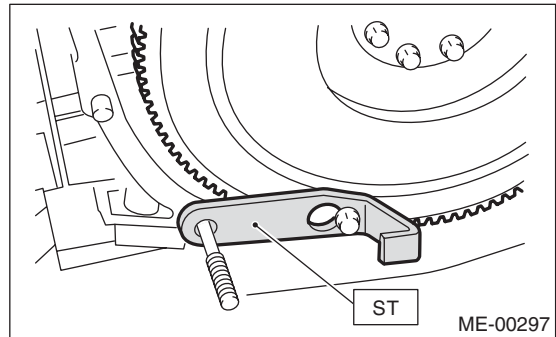

- AT model

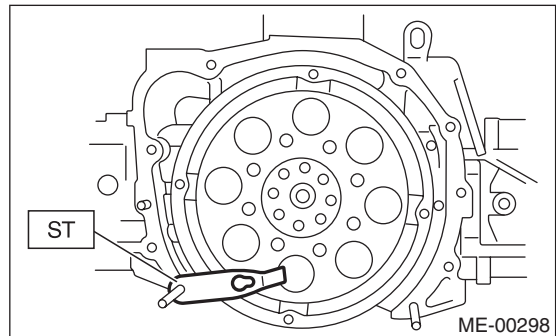

- 17) Remove the oil separator cover.
- 18) Remove the water by-pass pipe for heater.

19) Remove the water pump after loosening the bolts in alphabetical sequence as shown in the figure.

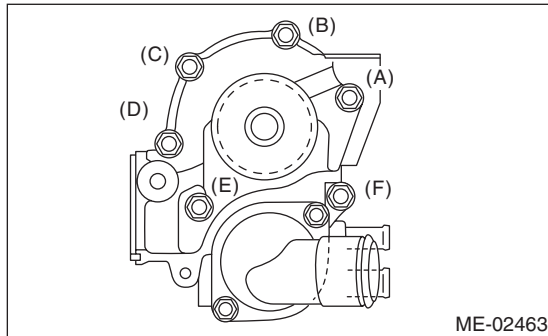

20) Remove the bolts which install oil pump onto cylinder block.

NOTE:

When disassembling and checking the oil pump, loosen the relief valve plug before removing the oil pump.

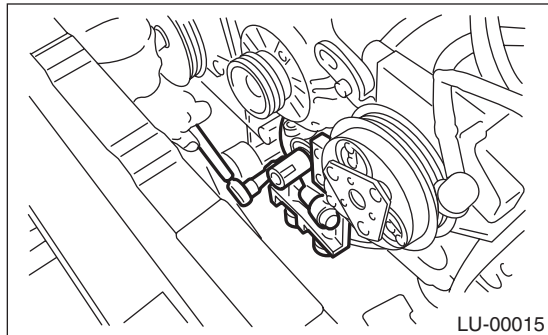

21) Remove the oil pump from cylinder block using a flat tip screwdriver.

CAUTION:

Be careful not to scratch the mating surface of cylinder block and oil pump.

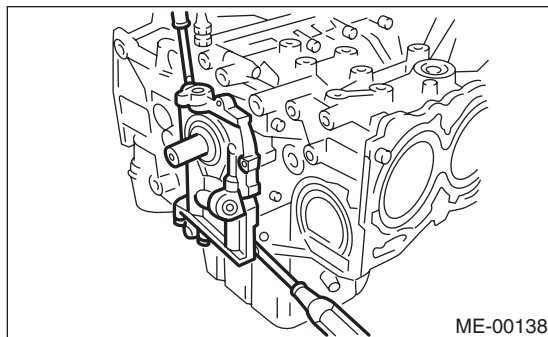

22) Remove the oil pan.

- (1) Set the part so that the cylinder block (LH) is on the upper side.
- (2) Remove the bolts which secure oil pan to cylinder block.
- (3) Insert an oil pan cutter blade between cylinder block-to-oil pan clearance and remove the oil pan.

CAUTION:

Do not use a screwdriver or similar tools in place of oil pan cutter.

- 23) Remove the oil strainer stay.
- 24) Remove the oil strainer.
- 25) Remove the baffle plate.
- 26) Remove the oil filter. <Ref. to LU(H4SO)-20, REMOVAL, Engine Oil Filter.>

Cylinder Block

MECHANICAL

27) Remove the water pipe.

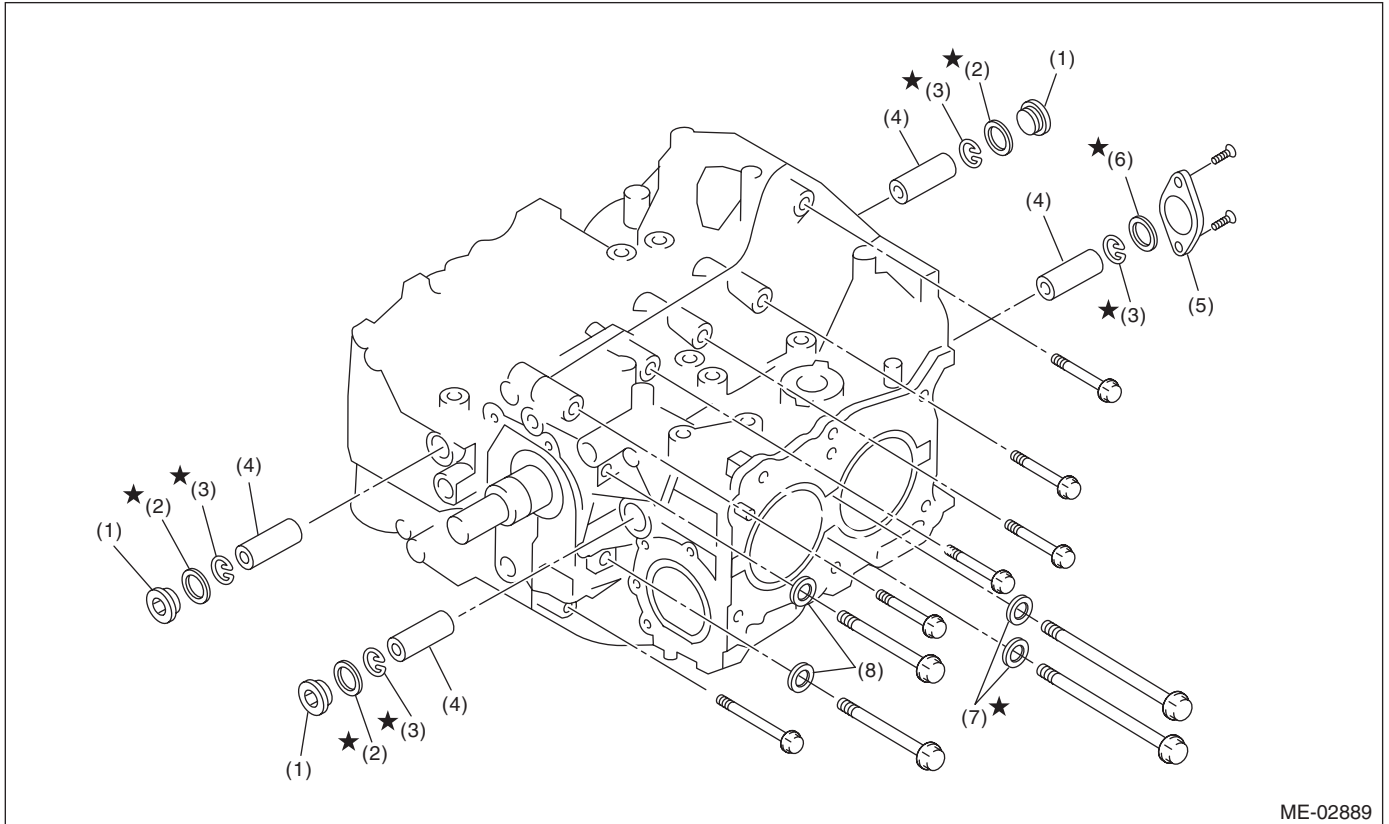
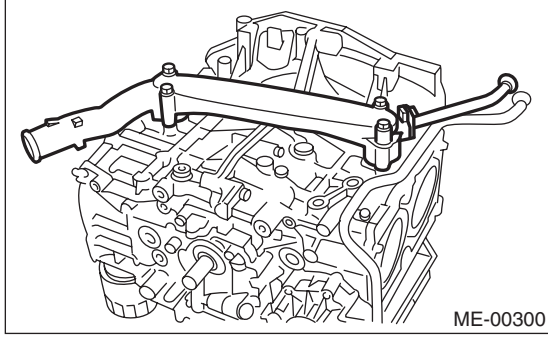

- (1) Service hole plug
- (2) Gasket
- (3) Snap ring

- (4) Piston pin
- (5) Service hole cover
- (6) O-ring

- (7) Seal washer
- (8) Washer

28) Remove the service hole plug using a hexagon wrench (14 mm).

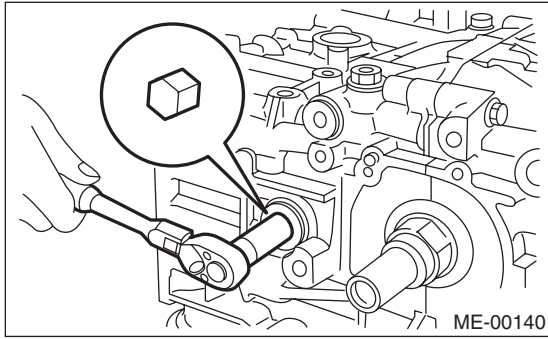

29) Remove the service hole cover.

30) Rotate the crankshaft to bring #1 and #2 pistons to bottom dead center position, then remove the piston snap ring through service hole of #1 and #2 cylinders.

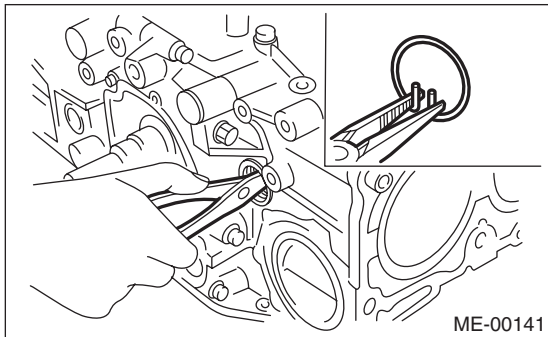

31) Draw out the piston pin from #1 and #2 pistons using ST.

NOTE:

Be careful not to confuse the original combination of piston, piston pin and cylinder.

ST 499097700 PISTON PIN REMOVER ASSY

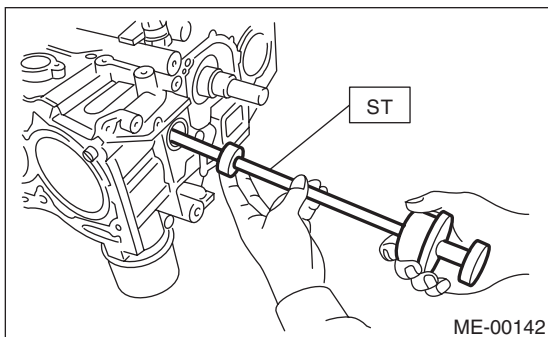

32) Similarly remove the piston pins from #3 and #4 pistons.

33) Remove the cylinder block connecting bolt on the RH side.

34) Loosen the cylinder block connecting bolt on the LH side by 2-3 turns.

35) Set the part so that the cylinder block (LH) is on the upper side, and remove the cylinder block connecting bolt.

Cylinder Block

MECHANICAL

36) Separate the cylinder block (RH) and (LH).

NOTE:

When separating the cylinder block, do not allow the connecting rod to fall or damage the cylinder block.

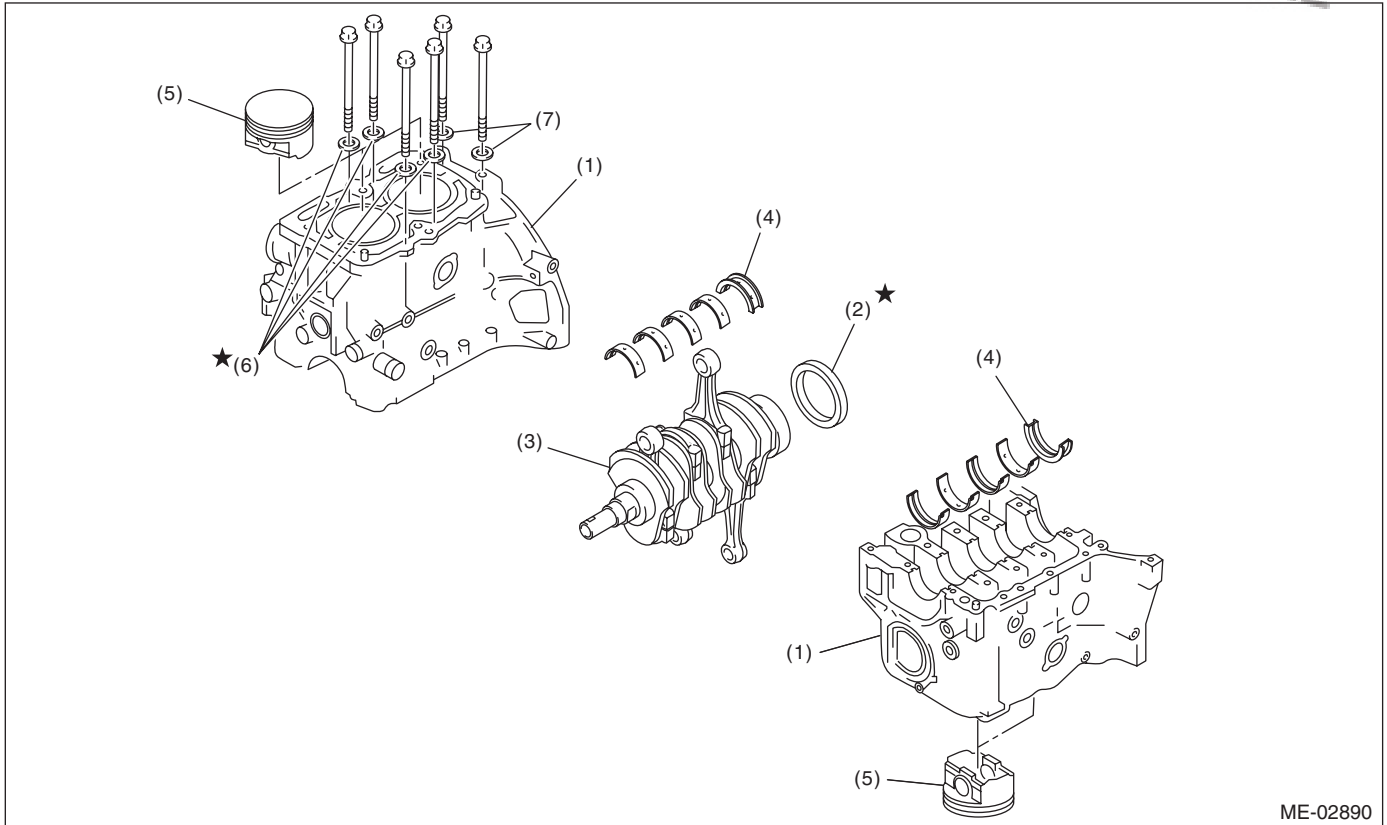

- | | | |
|--------------------|------------------------|------------|
| (1) Cylinder block | (4) Crankshaft bearing | (7) Washer |
| (2) Rear oil seal | (5) Piston | |
| (3) Crankshaft | (6) Seal washer | |

37) Remove the rear oil seal.

38) Remove the crankshaft along with the connecting rods.

39) Remove the crankshaft bearings from cylinder block using a hammer handle.

NOTE:

Do not confuse the combination of crankshaft bearings. Press the bearing at the end opposite to locking lip.

40) Draw out each piston from cylinder block using wooden bar or hammer handle.

NOTE:

Do not confuse the combination of piston and cylinder.

B: INSTALLATION

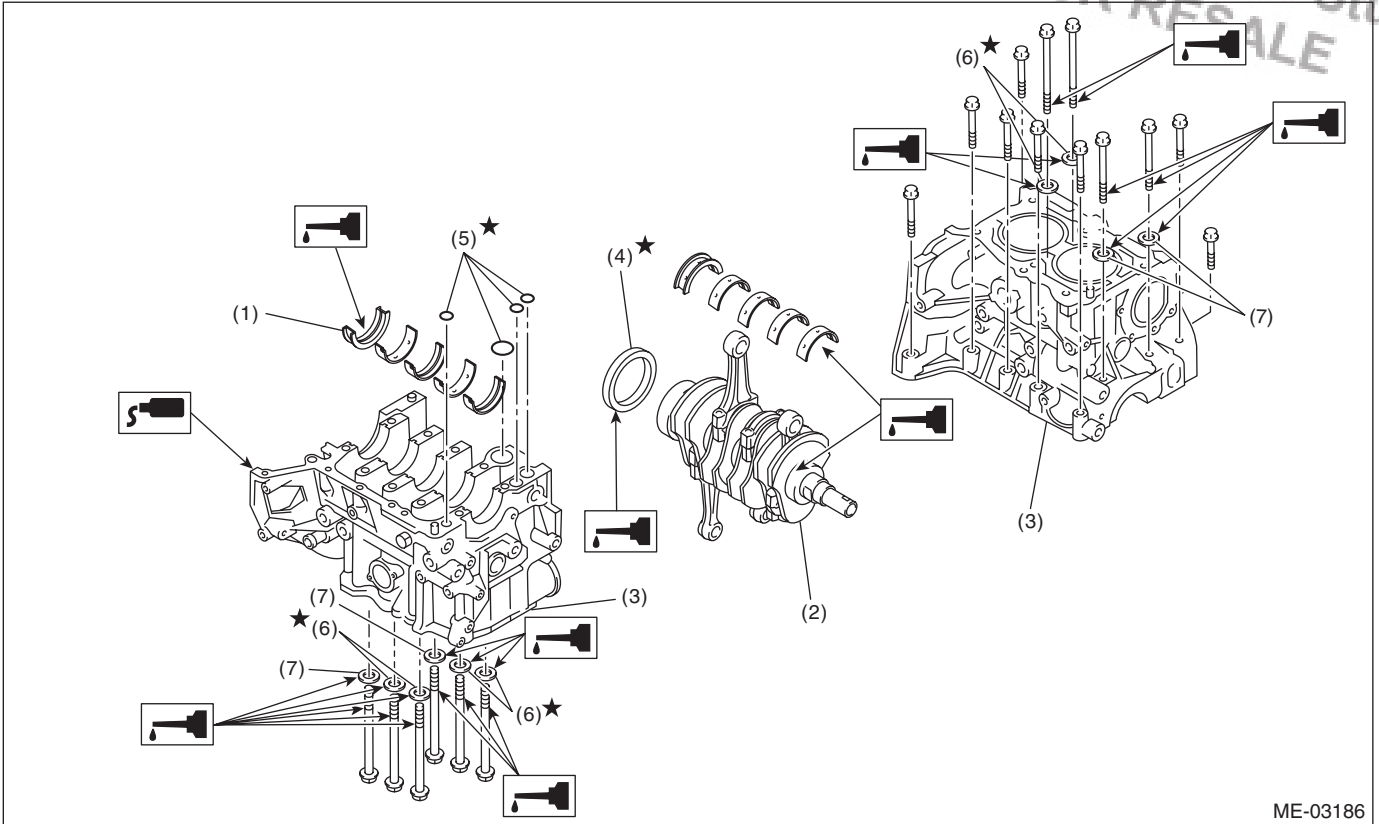

ME-03186

- | | | |
|------------------------|-------------------|-----------------|
| (1) Crankshaft bearing | (4) Rear oil seal | (6) Seal washer |
| (2) Crankshaft | (5) O-ring | (7) Washer |
| (3) Cylinder block | | |

- 1) Remove oil on the mating surface of cylinder block before installation. Apply a coat of engine oil to the bearing and crankshaft journal.
- 2) Position the crankshaft and O-ring on the cylinder block (RH).

NOTE:
Use new O-rings.

- 3) Apply liquid gasket to the mating surfaces of cylinder block (RH), and position the cylinder block (LH).

Liquid gasket:
THREE BOND 1215 (Part No. 004403007) or equivalent

NOTE:
Do not allow liquid gasket to jut into O-ring grooves, oil passages, bearing grooves, etc.

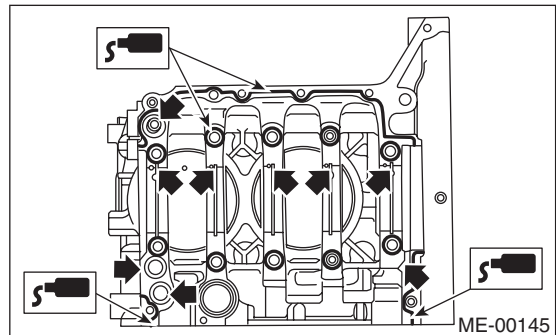

Cylinder Block

MECHANICAL

4) Apply a coat of engine oil to the washer and bolt thread.

NOTE:

Use a new seal washer.

5) Tighten the 10 mm cylinder block connecting bolts on the LH side (A — D) in alphabetical order.

Tightening torque:

10 N·m (1.0 kgf·m, 7.4 ft-lb)

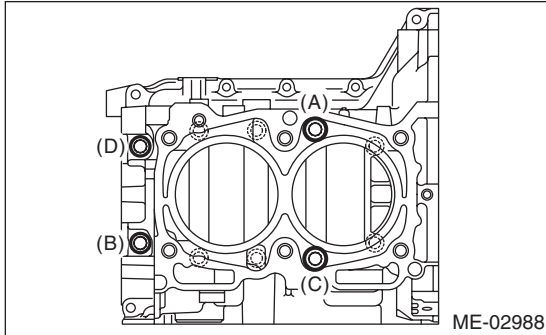

6) Tighten the 10 mm cylinder block connecting bolts on the RH side (E — J) in alphabetical order.

Tightening torque:

10 N·m (1.0 kgf·m, 7.4 ft-lb)

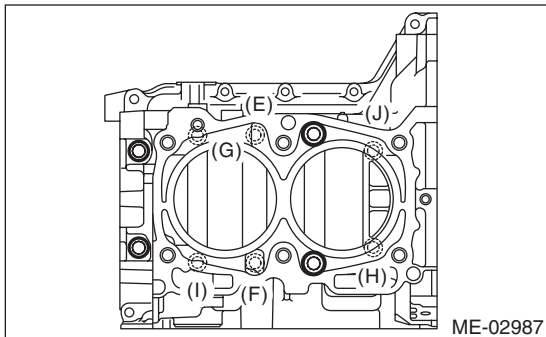

7) Tighten the LH side cylinder block connecting bolts (A — D) further in alphabetical order.

Tightening torque:

18 N·m (1.8 kgf·m, 13.3 ft-lb)

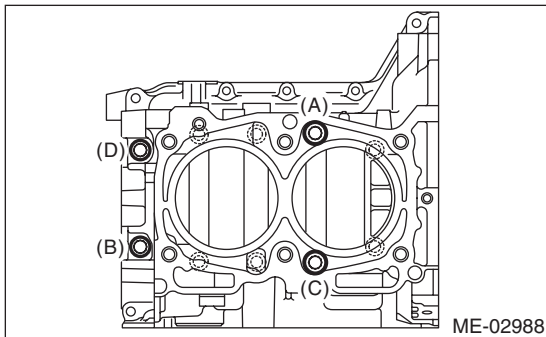

8) Tighten the RH side cylinder block connecting bolts (E — J) further in alphabetical order.

Tightening torque:

18 N·m (1.8 kgf·m, 13.3 ft-lb)

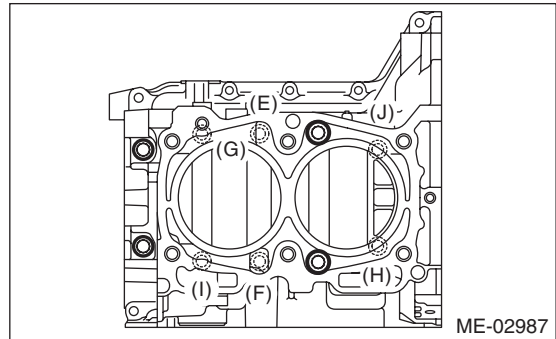

9) Tighten the LH side cylinder block connecting bolts (A — D) further in alphabetical order.

- (A), (C): Angle tightening

Tightening angle:

90°

- (B), (D): Torque tightening

Tightening torque:

40 N·m (4.1 kgf·m, 29.6 ft-lb)

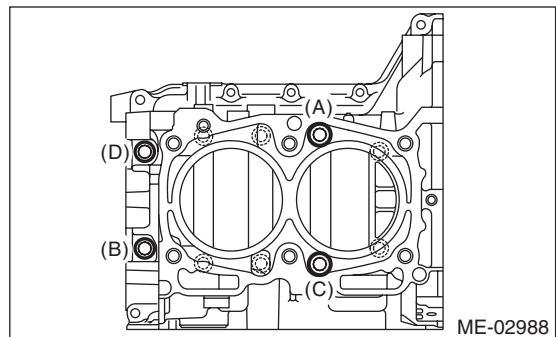

10) Tighten the RH side cylinder block connecting bolts (E — J) in alphabetical order.

Tightening angle:

90°

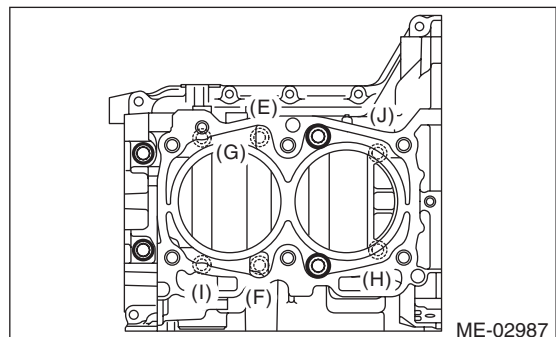

11) Tighten the 8 mm and 6 mm cylinder block connecting bolts on LH side (A — H) in alphabetical sequence.

Tightening torque:

(A) — (G): 25 N·m (2.5 kgf-m, 18.4 ft-lb)

(H): 6.4 N·m (0.65 kgf-m, 4.7 ft-lb)

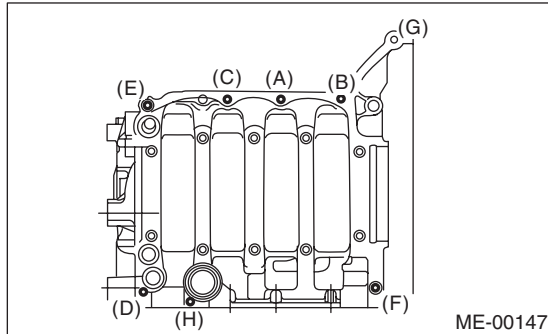

12) Apply a coat of engine oil to the oil seal periphery, then install the rear oil seal using ST1 and ST2.

NOTE:

Use a new rear oil seal.

ST1 499597100 CRANKSHAFT OIL SEAL GUIDE

ST2 499587200 CRANKSHAFT OIL SEAL INSTALLER

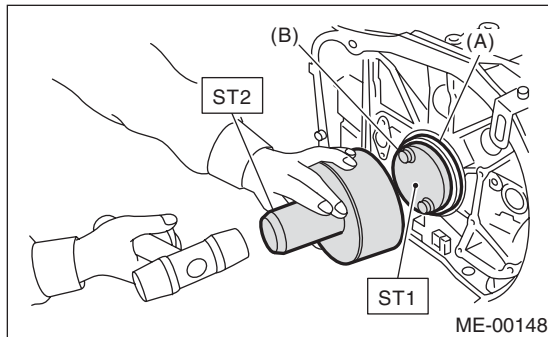

- (A) Rear oil seal
- (B) Flywheel attaching bolt

13) Position the top ring gap at (A) or (B) in the figure.

NOTE:

Assemble so that the piston ring mark “R” faces the top side of the piston.

14) Position the second ring gap at 180° on the reverse side the top ring gap.

NOTE:

Assemble so that the piston ring mark “R” faces the top side of the piston.

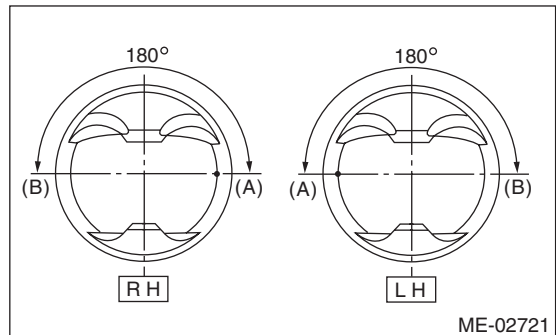

15) Position the upper rail gap at (C) in the figure.

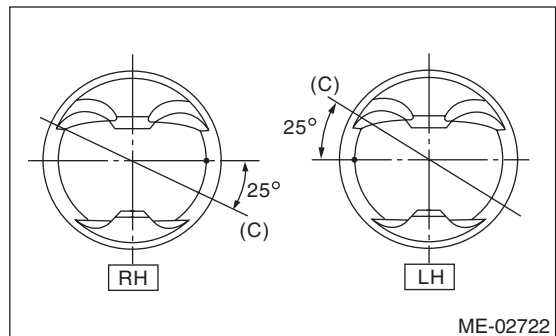

16) Align the upper rail spin stopper (E) to the side hole (D) on the piston.

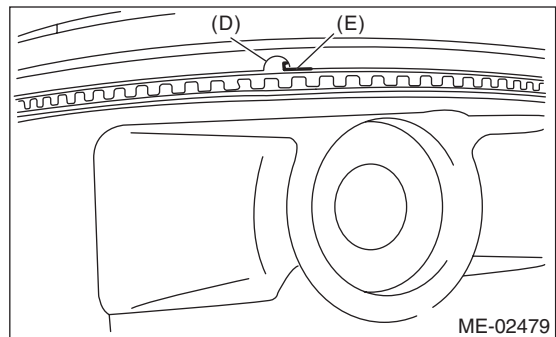

17) Position the expander gap at position (F) which is at 180° opposite side from the upper rail gap position (C).

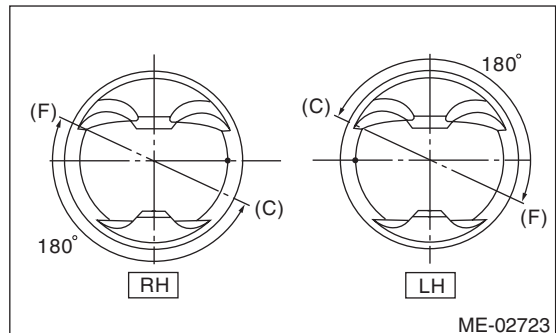

Cylinder Block

MECHANICAL

18) Position the lower rail gap at position (G) which is at 120° from the upper rail gap position (C).

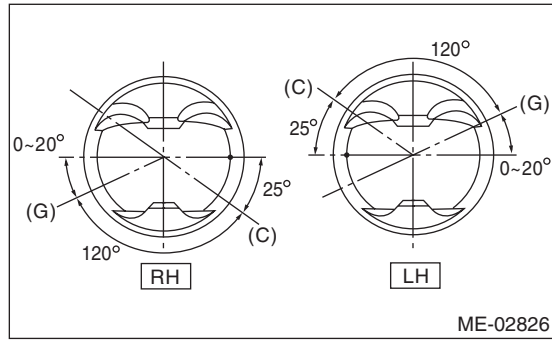

NOTE:

- Make sure ring gaps do not face the same direction.
- Make sure ring gaps are not within the piston skirt area.

19) Install the snap ring. Before installing the piston to the cylinder block, install the snap rings to the piston holes on the opposite side of the service holes on the cylinder block.

NOTE:

Use new snap rings.

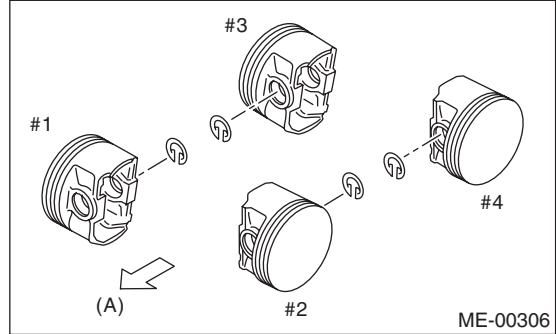

(A) Front side

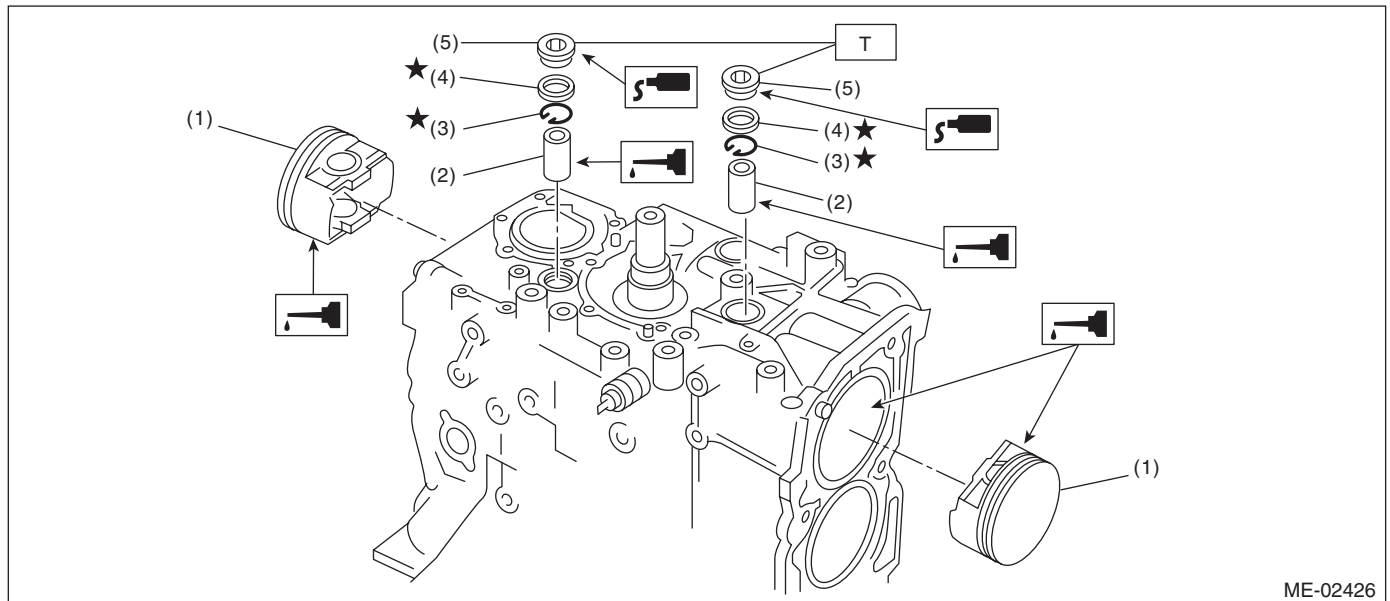

- | | |
|----------------|-----------------------|
| (1) Piston | (4) Gasket |
| (2) Piston pin | (5) Service hole plug |
| (3) Snap ring | |

Tightening torque: N·m (kgf·m, ft·lb)

T: 70 (7.1, 50.6)

20) Install piston.

- (1) Place the cylinder block to face the #1 and #2 cylinder side upward.
- (2) Using the ST1, turn the crankshaft so that #1 and #2 connecting rods are set at bottom dead center.

ST1 499987500 CRANKSHAFT SOCKET

- (3) Apply a coat of engine oil to the pistons and cylinders and insert pistons in their cylinders using ST2.

ST2 498747300 PISTON GUIDE

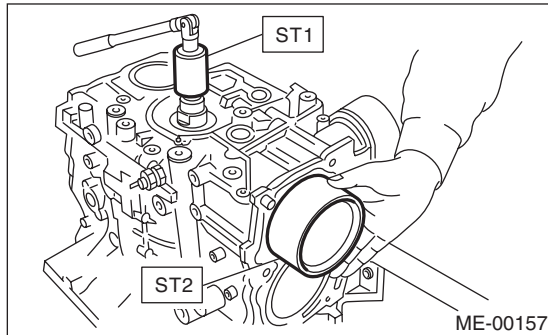

CAUTION:

Piston front mark faces towards the front of engine.

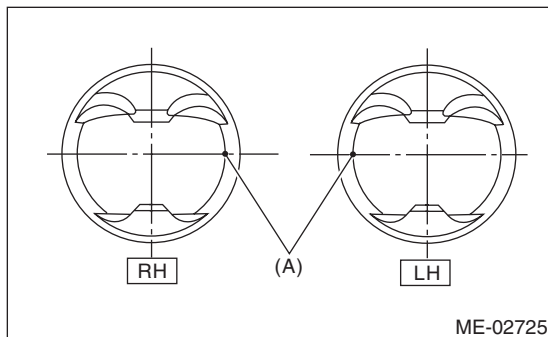

(A) Front mark

21) Install piston pin.

- (1) Apply a coat of engine oil to ST3.
- (2) Insert ST3 into the service hole to align piston pin hole with connecting rod small end.

ST3 499017100 PISTON PIN GUIDE

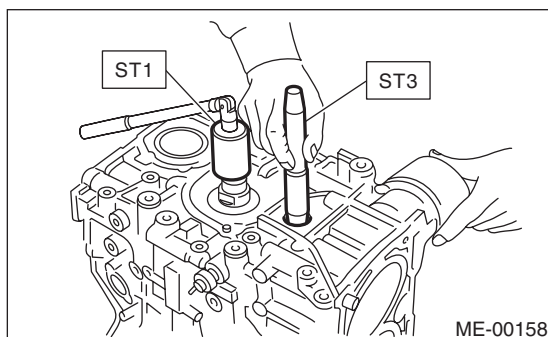

- (3) Apply a coat of engine oil to piston pin, and insert the piston pin into piston and connecting rod through service hole.
- (4) Install the snap ring.

NOTE:

Use new snap rings.

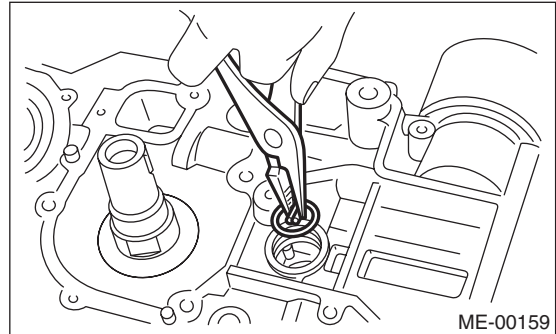

- (5) Apply liquid gasket to the threaded portion of the service hole plug.

Liquid gasket:

THREE BOND 1105 (Part No. 004403010) or equivalent

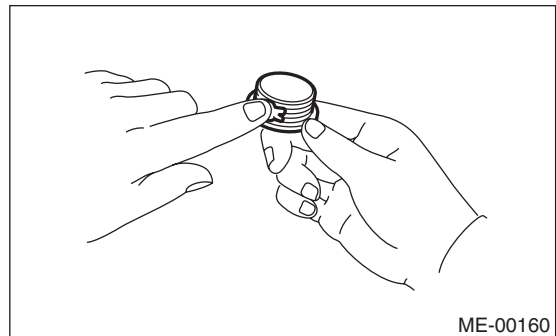

Cylinder Block

MECHANICAL

(6) Install the service hole plug and gasket.

NOTE:

Use a new gasket.

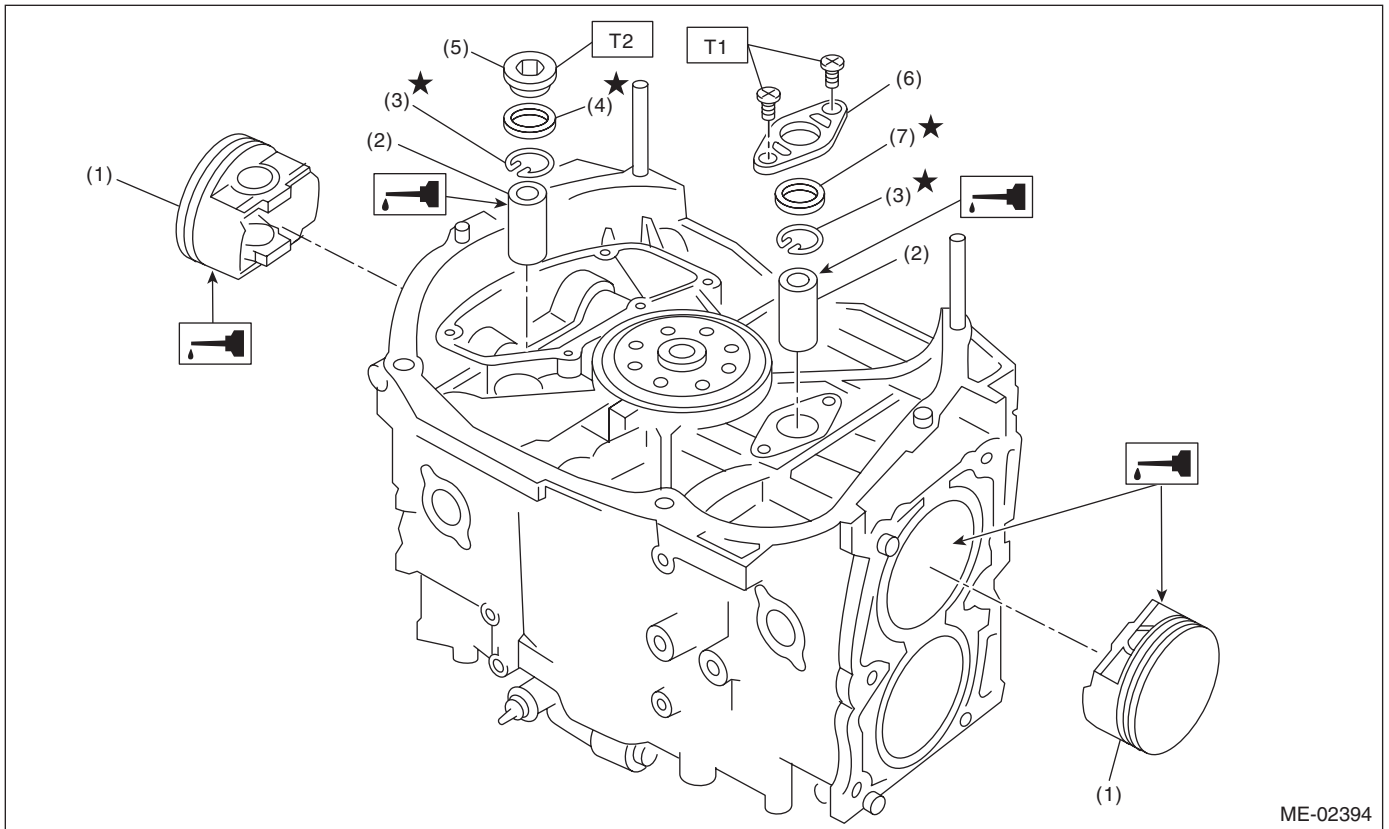
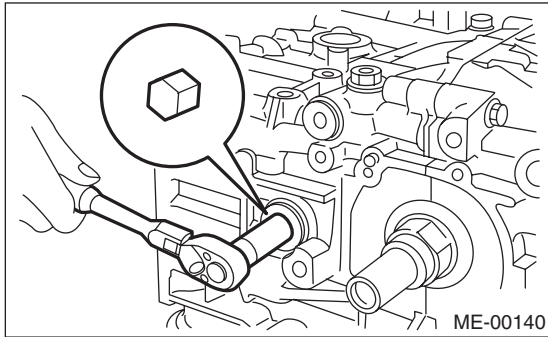

- | | |
|----------------|------------------------|
| (1) Piston | (5) Service hole plug |
| (2) Piston pin | (6) Service hole cover |
| (3) Snap ring | (7) O-ring |
| (4) Gasket | |

Tightening torque: N·m (kgf·m, ft·lb)

T1: 6.4 (0.65, 4.7)

T2: 70 (7.1, 50.6)

(7) Set the parts so that the #3 and #4 cylinders are on the upper side. Following the same procedures as used for #1 and #2 cylinders, install the pistons and piston pins.

22) Install the water pipe.

Tightening torque:

6.4 N·m (0.65 kgf-m, 4.7 ft-lb)

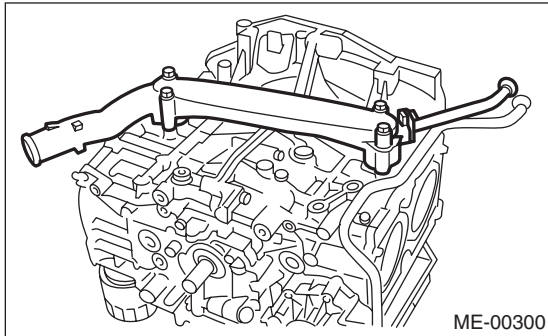

23) Install the baffle plate.

Tightening torque:

6.4 N·m (0.65 kgf-m, 4.7 ft-lb)

24) Install the oil strainer to the cylinder block.

NOTE:

Use new O-rings.

Tightening torque:

10 N·m (1.0 kgf-m, 7.4 ft-lb)

25) Install the oil strainer stay.

NOTE:

Tighten the oil strainer together with the baffle plate.

Tightening torque:

6.4 N·m (0.65 kgf-m, 4.7 ft-lb)

26) Apply liquid gasket to the mating surfaces, and install the oil pan.

NOTE:

Install within 5 min. after applying liquid gasket.

Liquid gasket:

THREE BOND 1207C (Part No. 004403012) or equivalent

Tightening torque:

5 N·m (0.5 kgf-m, 3.6 ft-lb)

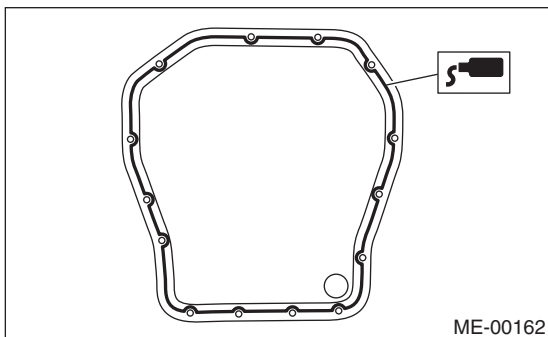

27) Apply liquid gasket to the mating surfaces and the threaded portion of bolt (A) shown in the figure (when reusing the bolt), and then install the oil separator cover.

NOTE:

Install within 5 min. after applying liquid gasket.

Liquid gasket:

Mating surface

THREE BOND 1217G (Part No. K0877Y0100) or equivalent

Bolt thread (A)

THREE BOND 1324 (Part No. 004403042) or equivalent

Tightening torque:

6.4 N·m (0.65 kgf-m, 4.7 ft-lb)

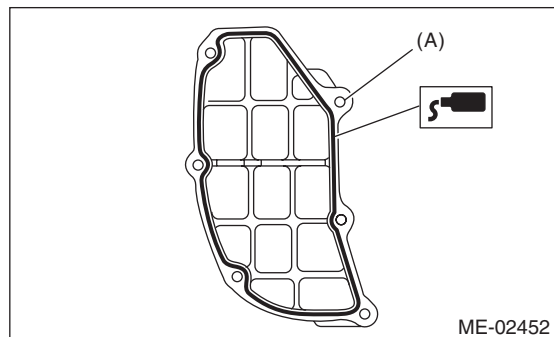

28) Install the flywheel. (MT model)

<Ref. to CL-17, INSTALLATION, Flywheel.>

To lock the crankshaft, use the ST.

ST 498497100 CRANKSHAFT STOPPER

Tightening torque:

72 N·m (7.3 kgf-m, 52.8 ft-lb)

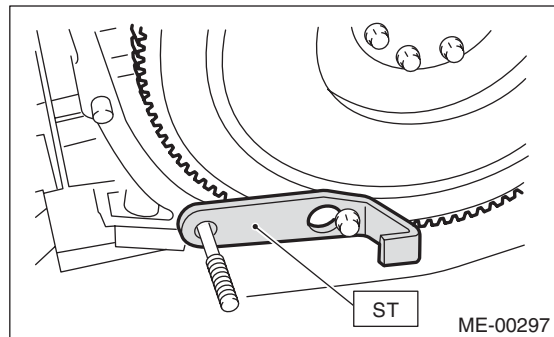

Cylinder Block

MECHANICAL

29) Install the drive plate.

To lock the crankshaft, use the ST.

ST 498497100 CRANKSHAFT STOPPER

Tightening torque:

72 N·m (7.3 kgf·m, 52.8 ft·lb)

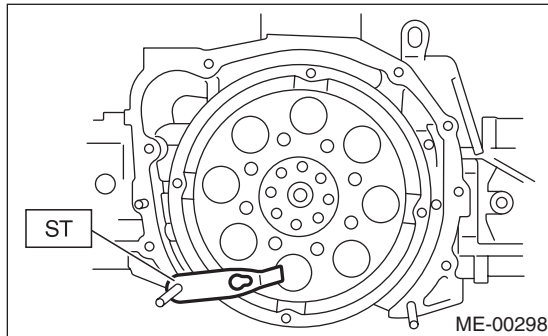

30) Install the clutch cover. (MT model)

31) Install the oil pump.

(1) Using the ST, install the front oil seal.

NOTE:

Use a new front oil seal.

ST 499587100 OIL SEAL INSTALLER

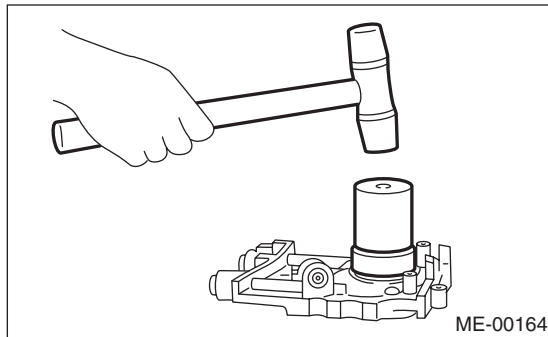

(2) Apply liquid gasket to the mating surfaces of oil pump.

Liquid gasket:

THREE BOND 1215 (Part No. 004403007) or equivalent

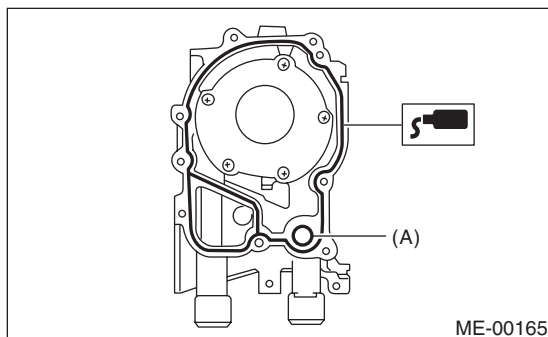

(A) O-ring

(3) Apply a coat of engine oil to the inside of oil seal.

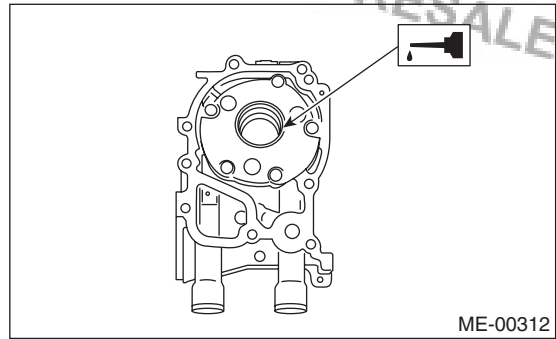

(4) Install the oil pump to cylinder block. Be careful not to damage the oil seal during installation.

NOTE:

- Make sure the oil seal lip is not folded.
- Align the flat surface of oil pumps inner rotor with crankshaft before installation.
- Use a new O-ring and new oil seal when installing the oil pump.
- When disassembly and check of the oil pump was performed, tighten the relief valve plug after attaching the oil pump.

Tightening torque:

T: 44 N·m (4.5 kgf·m, 32.5 ft·lb)

(5) Apply liquid gasket to the three bolts thread shown in figure. (When reusing the bolts)

Liquid gasket:

THREE BOND 1324 (Part No. 004403042) or equivalent

Tightening torque:

T: 6.4 N·m (0.65 kgf·m, 4.7 ft·lb)

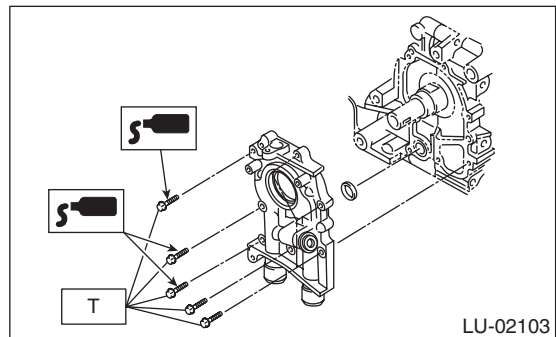

32) Install the water pump and gasket.

Tightening torque:

First: 12 N·m (1.2 kgf-m, 8.7 ft-lb)

Second: 12 N·m (1.2 kgf-m, 8.7 ft-lb)

NOTE:

- When installing the water pump, tighten bolts in two stages in alphabetical order as shown in the figure.
- Use a new gasket.

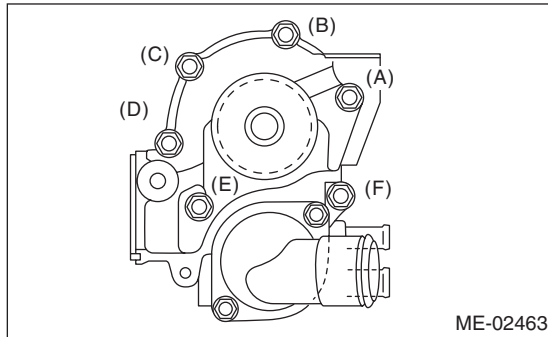

33) Install the water by-pass pipe for heater.

34) Using the ST, install the oil filter. <Ref. to LU(H4SO)-20, INSTALLATION, Engine Oil Filter.>

35) Tighten the cylinder head bolts. <Ref. to ME(H4SO)-58, INSTALLATION, Cylinder Head.>

36) Install the oil level gauge guide and tighten the bolts. (LH side)

37) Install the crank sprocket.

<Ref. to ME(H4SO)-50, INSTALLATION, Crank Sprocket.>

38) Install the cam sprocket. <Ref. to ME(H4SO)-48, INSTALLATION, Cam Sprocket.>

39) Install the timing belt. <Ref. to ME(H4SO)-44, INSTALLATION, Timing Belt.>

40) Adjust the valve clearance. <Ref. to ME(H4SO)-30, ADJUSTMENT, Valve Clearance.>

41) Install the rocker cover gasket to the rocker cover, install it to the cylinder head, and then connect the PCV hose.

NOTE:

Use a new gasket.

42) Install the timing belt cover.

<Ref. to ME(H4SO)-42, INSTALLATION, Timing Belt Cover.>

43) Install the crank pulley. <Ref. to ME(H4SO)-41, INSTALLATION, Crank Pulley.>

44) Install the generator and A/C compressor brackets on cylinder head.

45) Install the V-belts. <Ref. to ME(H4SO)-39, INSTALLATION, V-belt.>

46) Install the intake manifold.

<Ref. to FU(H4SO)-15, INSTALLATION, Intake Manifold.>

C: DISASSEMBLY

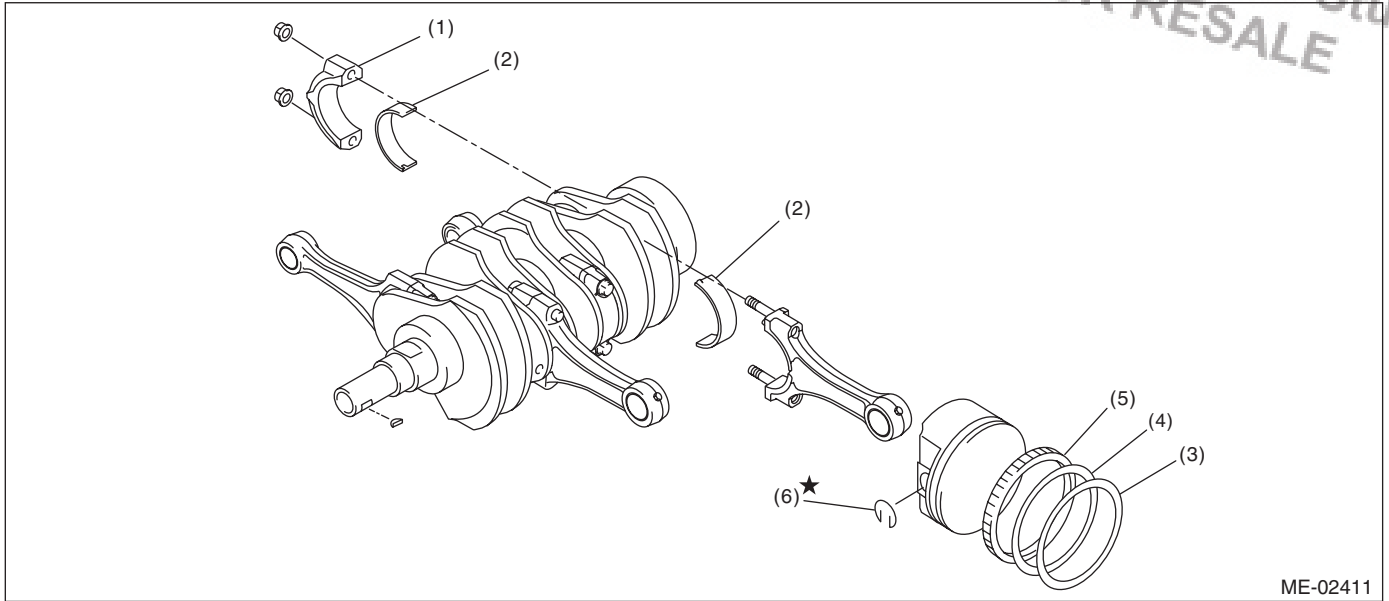

ME-02411

- | | | |
|----------------------------|-----------------|---------------|
| (1) Connecting rod cap | (3) Top ring | (5) Oil ring |
| (2) Connecting rod bearing | (4) Second ring | (6) Snap ring |

- 1) Remove the connecting rod cap.
- 2) Remove the connecting rod bearing.

NOTE:

Arrange the removed connecting rod, connecting rod cap and bearing in order, to prevent confusion.

3) Remove the piston rings using piston ring expander.

4) Remove the oil ring by hand.

NOTE:

Arrange the removed piston rings in proper order, to prevent confusion.

5) Remove the snap ring.

D: ASSEMBLY

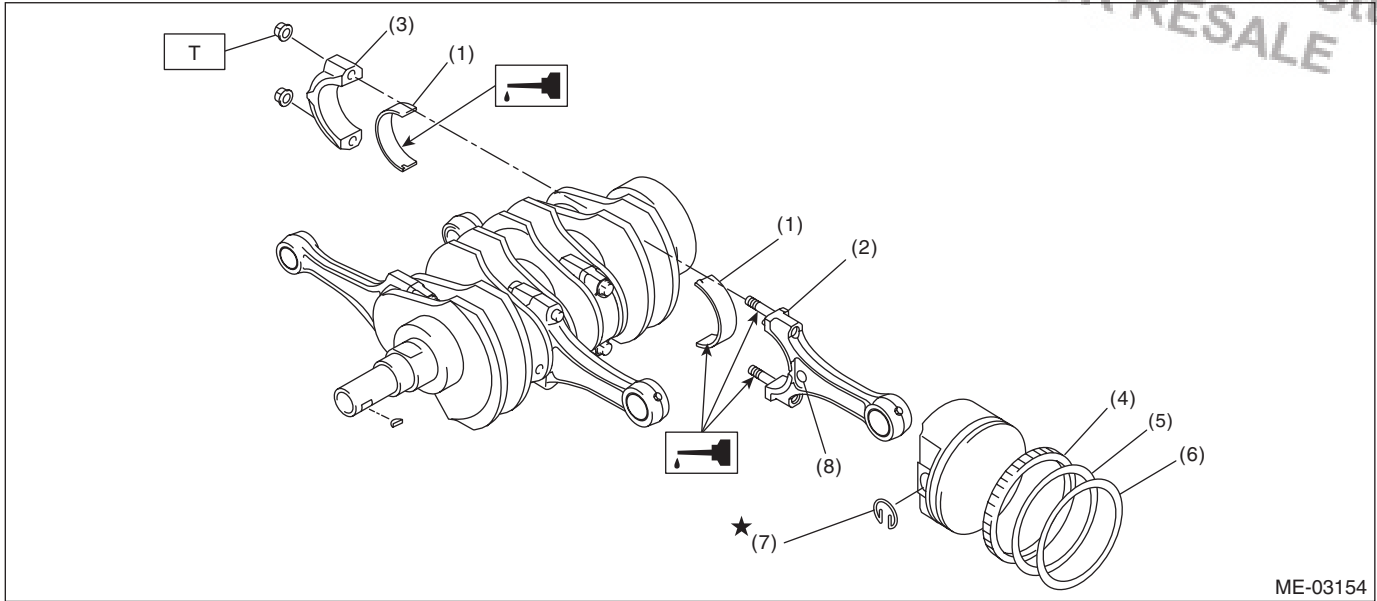

- | | |
|----------------------------|-----------------|
| (1) Connecting rod bearing | (5) Second ring |
| (2) Connecting rod | (6) Top ring |
| (3) Connecting rod cap | (7) Snap ring |
| (4) Oil ring | (8) Side mark |

Tightening torque: N·m (kgf·m, ft·lb)
T: 45 (4.6, 33.2)

- 1) Apply oil to the surfaces of the connecting rod bearings.
- 2) Install the connecting rod bearings on connecting rods and connecting rod caps.
- 3) Position each connecting rod with the side marking side facing forward, and install it.
- 4) Install the connecting rod cap with connecting rod nut.

NOTE:

- Each connecting rod has its own mating cap. Make sure that they are assembled correctly by checking their matching number.
 - When tightening the connecting rod nuts, apply oil on the threads.
- 5) Install the expander, lower rail and upper rail by hand.
 - 6) Install the second ring and top ring using piston ring expander.

E: INSPECTION

1. CYLINDER BLOCK

- 1) Check for cracks or damage. Use liquid penetrant tester on the important sections to check for fissures. Check that there are no marks of gas leaking or water leaking on gasket installing surface.
- 2) Check the oil passages for clogging.
- 3) Inspect the cylinder block surface that mates with cylinder head for warping by using a straight edge, and correct by grinding if necessary.

Warping limit:
0.025 mm (0.00098 in)

Grinding limit:
0.1 mm (0.004 in)

Standard height of cylinder block:
201.0 mm (7.91 in)

2. CYLINDER AND PISTON

1) The cylinder bore size is stamped on the front upper face of the cylinder block.

NOTE:

- Measurement should be performed at a temperature of 20°C (68°F).
- Standard sized pistons are classified into two grades, "A" and "B". These grades should be used as guide lines in selecting a standard piston.

Standard diameter:

- A: 99.505 — 99.515 mm (3.9175 — 3.9179 in)**
- B: 99.495 — 99.505 mm (3.9171 — 3.9175 in)**

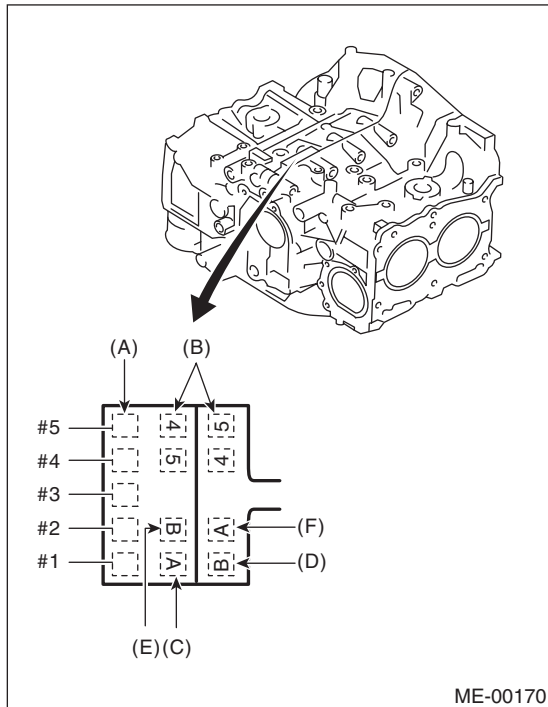

- (A) Main journal size mark
- (B) Cylinder block (RH) — (LH) combination mark
- (C) #1 cylinder bore size mark
- (D) #2 cylinder bore size mark
- (E) #3 cylinder bore size mark
- (F) #4 cylinder bore size mark

2) How to measure the inner diameter of each cylinder:

Measure the inner diameter of each cylinder in both the thrust and piston pin directions at the heights as shown in the figure, using a cylinder bore gauge.

NOTE:

Measurement should be performed at a temperature of 20°C (68°F).

Taper:

- Standard**
0.015 mm (0.0006 in)
- Limit**
0.050 mm (0.0020 in)

Out-of-roundness:

- Standard**
0.010 mm (0.0004 in)
- Limit**
0.050 mm (0.0020 in)

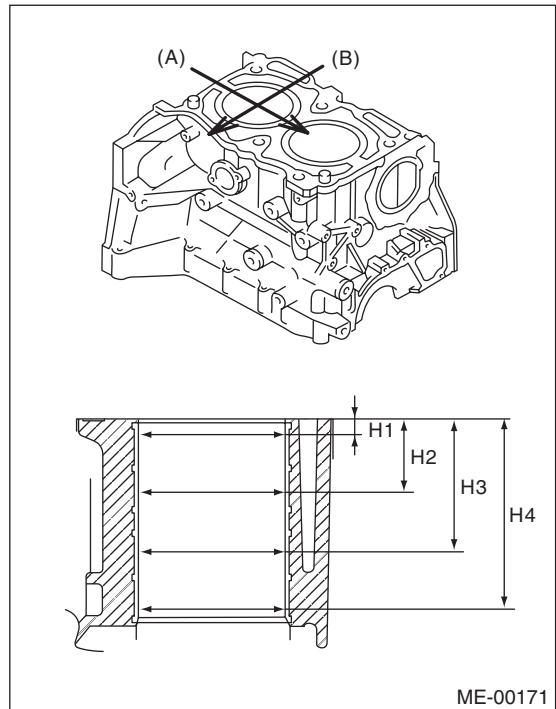

- (A) Piston pin direction
- (B) Thrust direction
- H1 10 mm (0.39 in)
- H2 45 mm (1.77 in)
- H3 80 mm (3.15 in)
- H4 115 mm (4.53 in)

3) When the piston is to be replaced due to general or cylinder wear, determine a suitable sized piston by measuring the piston clearance.

4) How to measure the outer diameter of each cylinder:

Measure the outer diameter of each piston at the height as shown in the figure. (Thrust direction)

NOTE:

Measurement should be performed at a temperature of 20°C (68°F).

Piston grade point H:

38.2 mm (1.504 in)

Standard

A: 99.505 — 99.515 mm (3.9175 — 3.9179 in)

B: 99.495 — 99.505 mm (3.9171 — 3.9175 in)

0.25 mm (0.0098 in) oversize

99.745 — 99.765 mm (3.9270 — 3.9278 in)

0.50 mm (0.0197 in) oversize

99.995 — 100.015 mm (3.9368 — 3.9376 in)

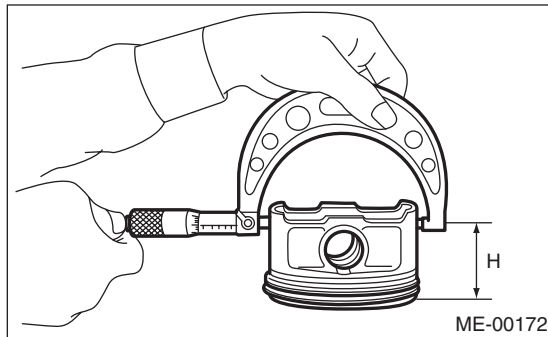

5) Calculate the clearance between cylinder and piston.

NOTE:

Measurement should be performed at a temperature of 20°C (68°F).

Cylinder to piston clearance at 20°C (68°F):

Standard

-0.010 — 0.010 mm (-0.00039 — 0.00039 in)

Limit

0.030 mm (0.0012 in)

6) Boring and honing

(1) If any of the value of taper, out-of-roundness, or cylinder-to-piston clearance exceeds the limit or if there is any damage on the cylinder wall, rebores it for replacement with an oversize piston.

CAUTION:

- When any of the cylinders needs reboring, other cylinders must be bored at the same time, and replaced with oversize pistons.
- Do not perform boring on one cylinder only. Do not replace only a single cylinder for an oversize piston.

(2) If the cylinder inner diameter exceeds the limit after boring and honing, replace the cylinder block.

NOTE:

Immediately after reboring, the cylinder diameter may differ from its real diameter due to temperature rise. Thus, pay attention when measuring the cylinder diameter.

Cylinder inner diameter limit (diameter):

100.005 mm (3.937 in)

3. PISTON AND PISTON PIN

- 1) Check the piston and piston pin for breaks, cracks or wear. Replace if faulty.
- 2) Check the piston ring groove for wear and damage. Replace if faulty.
- 3) Make sure that the piston pin can be inserted into the piston pin hole with a finger at 20°C (68°F). Replace if faulty.

Clearance between piston hole and piston pin:

Standard

0.004 — 0.008 mm (0.0002 — 0.0003 in)

Limit

0.020 mm (0.0008 in)

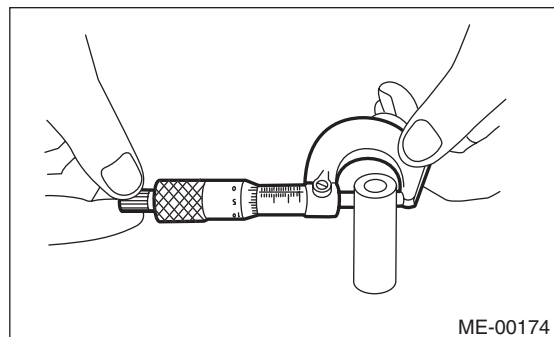
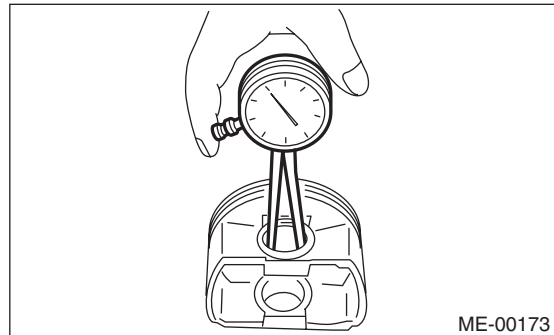

MECHANICAL

4) Check the snap ring installation groove (A) on the piston for burr. If necessary, remove burr from the groove so that the piston pin can lightly move.

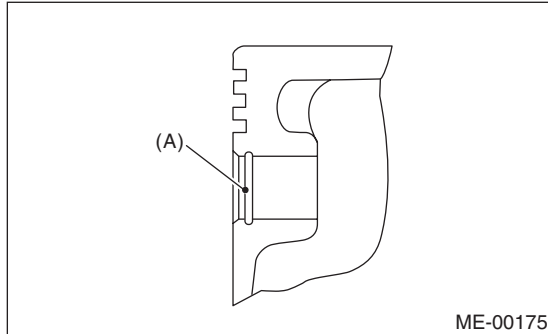

5) Check the piston pin snap ring for distortion, cracks and wear.

4. PISTON RING

1) If the piston ring is broken, damaged or worn, or if its tension is insufficient, or when the piston is replaced, replace the piston ring with a new part of the same size as the piston.

NOTE:

- The top ring and second ring have the mark to determine the direction to install on them. When installing them to piston, face this mark to the top side.
- Oil ring consists of the upper rail, expander and lower rail. Be careful about the direction of rail when installing the oil ring to piston.

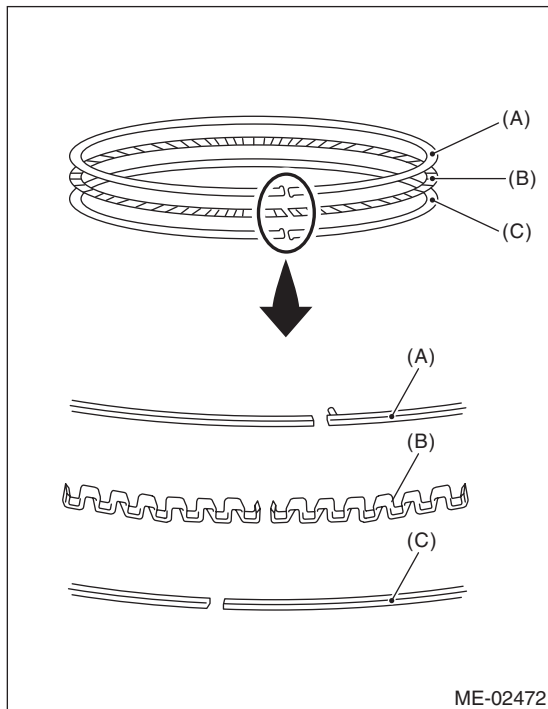

- (A) Upper rail
- (B) Expander
- (C) Lower rail

2) Clean the piston ring groove and piston ring.
3) Squarely place the piston ring and oil ring in cylinder, and measure the piston ring gap with a thickness gauge.

		Standard mm (in)	Limit mm (in)
Piston ring closed gap	Top ring	0.20 — 0.35 (0.0079 — 0.0138)	1.0 (0.039)
	Second ring	0.37 — 0.52 (0.0144 — 0.0203)	1.0 (0.039)
	Oil ring rail	0.20 — 0.50 (0.0079 — 0.0197)	1.5 (0.059)

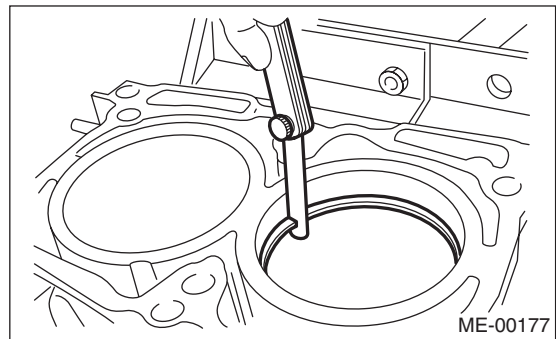

4) Measure the clearance between piston ring and piston ring groove with a thickness gauge.

NOTE:

Before measuring the clearance, clean the piston ring groove and piston ring.

		Standard mm (in)	Limit mm (in)
Clearance between piston ring and piston ring groove	Top ring	0.040 — 0.080 (0.0016 — 0.0031)	0.15 (0.0059)
	Second ring	0.030 — 0.070 (0.0012 — 0.0028)	0.15 (0.0059)

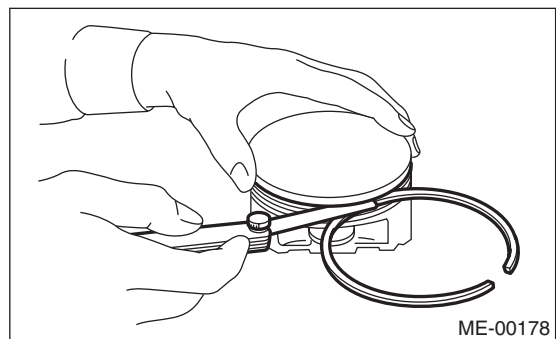

5. CONNECTING ROD

- 1) Replace the connecting rod, if the large or small end thrust surface is damaged.
- 2) Check for bend or twist using a connecting rod aligner. Replace the connecting rod if the bend or twist exceeds the limit.

Limit of bend or twist per 100 mm (3.94 in) in length:

0.10 mm (0.0039 in)

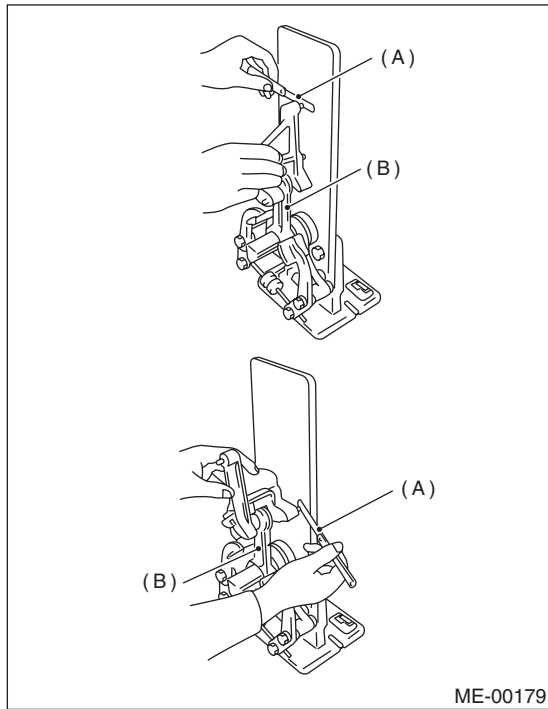

(A) Thickness gauge
(B) Connecting rod

- 3) Install the connecting rod fitted with bearing to crankshaft and measure the thrust clearance. Replace the connecting rod if the thrust clearance exceeds the limit.

Connecting rod thrust clearance:

Standard

0.070 — 0.330 mm (0.0028 — 0.0130 in)

Limit

0.4 mm (0.016 in)

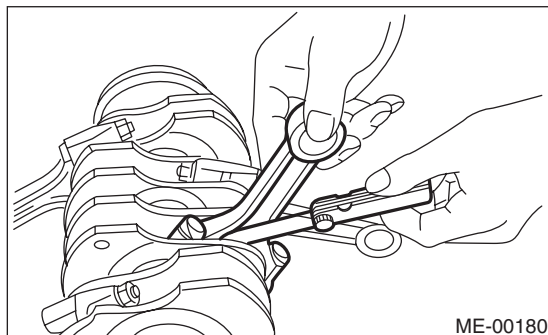

ME-00180

- 4) Inspect the connecting rod bearing for scar, peeling, seizure, melting, wear, etc.
- 5) Measure the oil clearance on each connecting rod bearing using plastigauge. If any oil clearance is not within specification, replace the defective bearing with a new part of standard size or under-size as necessary. (See the table below.)

Connecting rod oil clearance:

Standard

0.016 — 0.044 mm (0.00063 — 0.0017 in)

Limit

0.05 mm (0.0020 in)

Unit: mm (in)		
Bearing	Bearing size (Thickness at center)	Outer diameter of crank pin
Standard	1.492 — 1.501 (0.0587 — 0.0591)	51.984 — 52.000 (2.0466 — 2.0472)
0.03 (0.0012) undersize	1.510 — 1.513 (0.0594 — 0.0596)	51.954 — 51.970 (2.0454 — 2.0461)
0.05 (0.0020) undersize	1.520 — 1.523 (0.0598 — 0.0600)	51.934 — 51.950 (2.0446 — 2.0453)
0.25 (0.0098) undersize	1.620 — 1.623 (0.0638 — 0.0639)	51.734 — 51.750 (2.0368 — 2.0374)

- 6) Inspect the bushing at connecting rod small end, and replace if worn or damaged.
- 7) Measure the piston pin clearance at connecting rod small end. Replace it with a new part if the limit has been exceeded.

Clearance between piston pin and bushing:

Standard

0 — 0.022 mm (0 — 0.0009 in)

Limit

0.030 mm (0.0012 in)

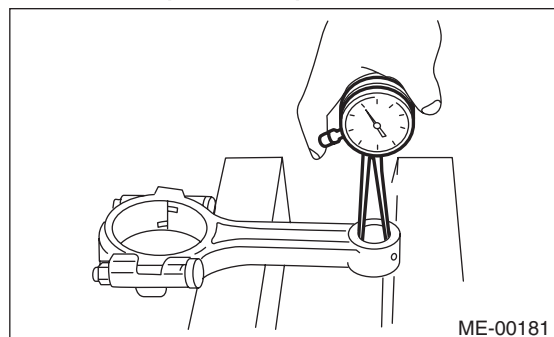

ME-00181

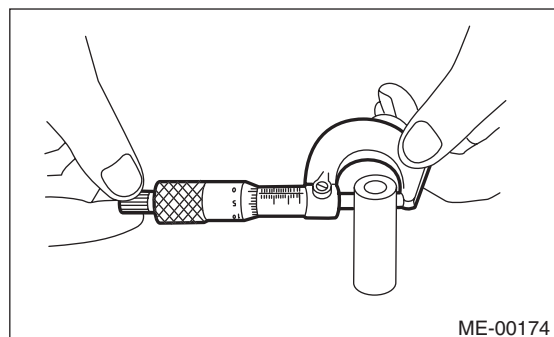

ME-00174

MECHANICAL

8) The replacement procedure for the connecting rod small end bushing is as follows.

- (1) Remove the bushing from connecting rod with ST and press.
- (2) Press the bushing with ST after applying oil on the periphery of bushing.

ST 499037100 CONNECTING ROD BUSHING REMOVER AND INSTALLER

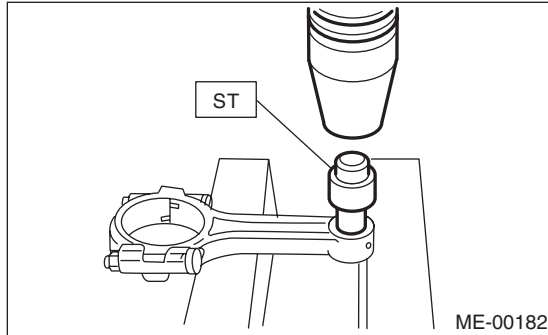

(3) Make two 3 mm (0.12 in) holes in the pressed bushing by aligning with the pre-manufactured holes on the connecting rod. Then, ream the inside of bushing.

(4) After completion of reaming, clean the bushing to remove chips.

6. CRANKSHAFT AND CRANKSHAFT BEARING

1) Clean the crankshaft completely, and check it for cracks using liquid penetrant tester. Replace if faulty.

2) Measure the bend of crankshaft. If it exceeds the limit, correct or replace it.

NOTE:

If a suitable V-block is not available, install #1 and #5 crankshaft bearing on cylinder block, position the crankshaft on these bearings, and then measure the crankshaft bend using a dial gauge.

Crankshaft bend limit:
0.035 mm (0.0014 in)

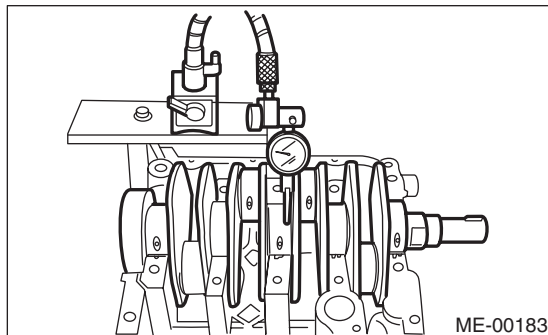

3) Inspect the crank journal and crank pin for wear. If the limit is exceeded, replace the bearing with a suitable (undersize) bearing, and replace or grind to correct the crankshaft as necessary. When grinding the crank journal or crank pin, finish them to the specified dimensions according to the undersize bearing to be used.

Crank pin:

Out-of-roundness

0.003 mm (0.0001 in)

Cylindricity

0.004 mm (0.0002 in)

Grinding limit

To 51.750 mm (2.0374 in) dia.

Crank journal:

Out-of-roundness

0.005 mm (0.0002 in)

Cylindricity

0.006 mm (0.0002 in)

Grinding limit

To 59.758 mm (2.3527 in) dia.

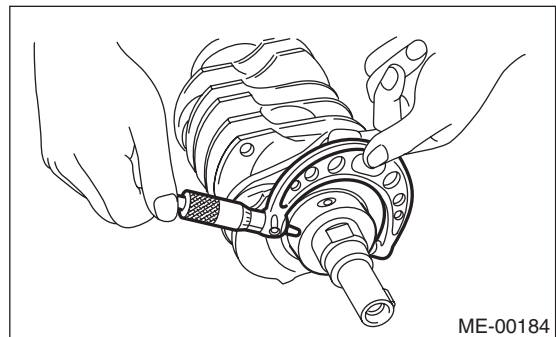

		Unit: mm (in)		
		Crank journal outer diameter		Crank pin outer diameter
		#1, #3	#2, #4, #5	
Standard	Journal O.D.	59.992 — 60.008 (2.3619 — 2.3625)	59.992 — 60.008 (2.3619 — 2.3625)	51.984 — 52.000 (2.0466 — 2.0472)
	Bearing size (Thickness at center)	1.998 — 2.011 (0.0787 — 0.0792)	2.000 — 2.013 (0.0787 — 0.0793)	1.492 — 1.501 (0.0587 — 0.0591)
0.03 (0.0012) undersize	Journal O.D.	59.962 — 59.978 (2.3607 — 2.3613)	59.962 — 59.978 (2.3607 — 2.3613)	51.954 — 51.970 (2.0454 — 2.0461)
	Bearing size (Thickness at center)	2.017 — 2.020 (0.0794 — 0.0795)	2.019 — 2.022 (0.0795 — 0.0796)	1.510 — 1.513 (0.0594 — 0.0596)
0.05 (0.0020) undersize	Journal O.D.	59.942 — 59.958 (2.3599 — 2.3605)	59.942 — 59.958 (2.3599 — 2.3605)	51.934 — 51.950 (2.0446 — 2.0453)
	Bearing size (Thickness at center)	2.027 — 2.030 (0.0798 — 0.0799)	2.029 — 2.032 (0.0799 — 0.0800)	1.520 — 1.523 (0.0598 — 0.0600)
0.25 (0.0098) undersize	Journal O.D.	59.742 — 59.758 (2.3520 — 2.3527)	59.742 — 59.758 (2.3520 — 2.3527)	51.734 — 51.750 (2.0368 — 2.0374)
	Bearing size (Thickness at center)	2.127 — 2.130 (0.0837 — 0.0839)	2.129 — 2.132 (0.0838 — 0.0839)	1.620 — 1.623 (0.0638 — 0.0639)

4) Use a thickness gauge to measure the thrust clearance of crankshaft at center bearing. Replace the bearing if the thrust clearance exceeds the limit.

Crankshaft thrust clearance:

Standard

0.030 — 0.115 mm (0.0012 — 0.0045 in)

Limit

0.25 mm (0.0098 in)

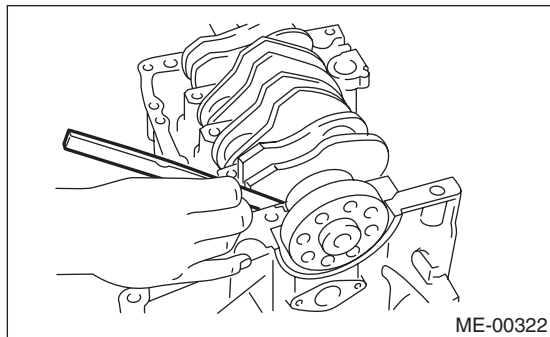

5) Inspect individual crankshaft bearings for signs of flaking, seizure, melting and wear.

6) Measure the oil clearance on each crankshaft bearing using plastigauge. If the measurement exceeds the limit, replace the faulty bearing with an undersized bearing, and replace or grind to correct the crankshaft as necessary.

Crankshaft oil clearance:

Standard

0.010 — 0.030 mm (0.0004 — 0.0012 in)

Limit

0.040 mm (0.0016 in)

22. Oil Switching Solenoid Valve

A: REMOVAL

1. RH SIDE

1) Disconnect the ground cable from the battery.

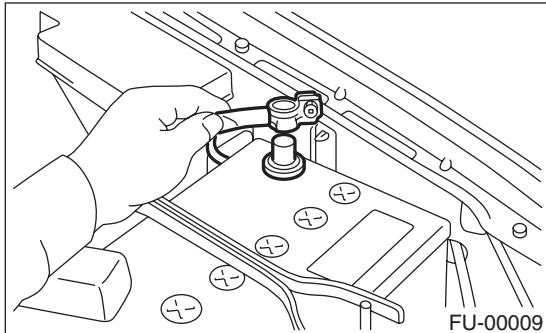

2) Remove the air intake chamber. <Ref. to IN(H4SO)-6, REMOVAL, Air Intake Chamber.>

3) Remove the engine harness connector from the bracket.

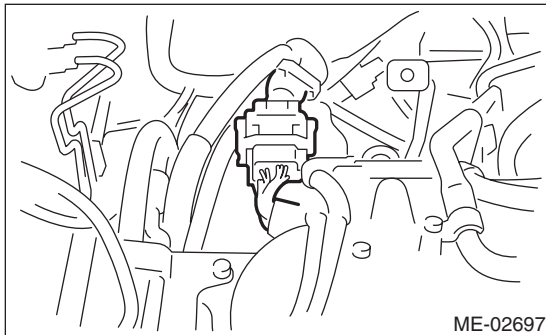

4) Disconnect the connector from the oil switching solenoid valve.

5) Remove the oil switching solenoid valve.

6) Remove the variable valve lift diagnosis oil pressure switch. <Ref. to FU(H4SO)-34, REMOVAL, Variable Valve Lift Diagnosis Oil Pressure Switch.>

7) Remove the oil temperature sensor. <Ref. to FU(H4SO)-35, REMOVAL, Oil Temperature Sensor.>

8) Remove the oil switching solenoid valve holder from the cylinder head.

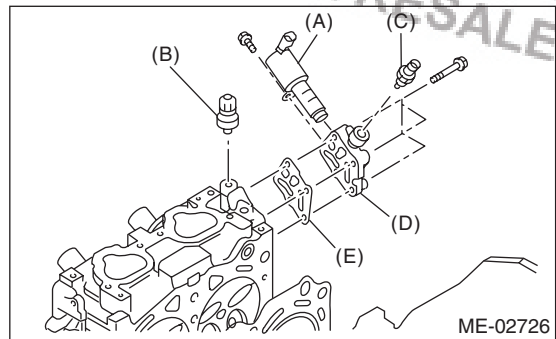

(A) Oil switching solenoid valve

(B) Variable valve lift diagnosis oil pressure switch

(C) Oil temperature sensor

(D) Oil switching solenoid valve holder

(E) Gasket

2. LH SIDE

1) Disconnect the ground cable from the battery.

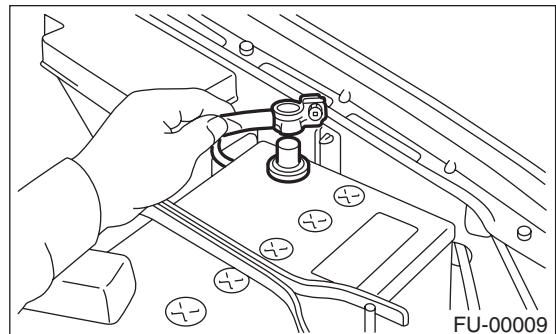

2) Remove the V-belts. <Ref. to ME(H4SO)-39, REMOVAL, V-belt.>

3) Remove the crank pulley. <Ref. to ME(H4SO)-41, REMOVAL, Crank Pulley.>

4) Remove the timing belt cover. <Ref. to ME(H4SO)-42, REMOVAL, Timing Belt Cover.>

5) Remove the timing belt. <Ref. to ME(H4SO)-43, REMOVAL, Timing Belt.>

6) Remove the cam sprocket. <Ref. to ME(H4SO)-48, REMOVAL, Cam Sprocket.>

7) Remove the timing belt cover No. 2 (LH).

8) Disconnect the connector from the oil switching solenoid valve.

9) Remove the oil switching solenoid valve.

10) Remove the variable valve lift diagnosis oil pressure switch. <Ref. to FU(H4SO)-34, REMOVAL, Variable Valve Lift Diagnosis Oil Pressure Switch.>

11) Remove the oil switching solenoid valve holder from the cylinder head.

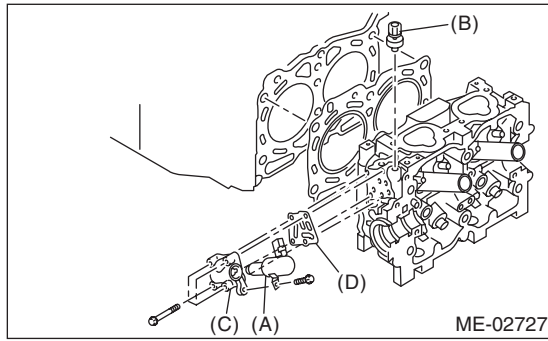

- (A) Oil switching solenoid valve
- (B) Variable valve lift diagnosis oil pressure switch
- (C) Oil switching solenoid valve holder
- (D) Gasket

B: INSTALLATION

1. RH SIDE

Install in the reverse order of removal.

NOTE:

- Use a new gasket.
- Apply to the threads of the variable valve lift diagnosis oil pressure switch.
- Install the oil switching solenoid valve to the holder, then install it to the cylinder head.

Liquid gasket:

THREE BOND 1324 (Part No. 004403042)

Tightening torque:

- T1: 8 N·m (0.8 kgf-m, 5.9 ft-lb)**
- T2: 10 N·m (1.0 kgf-m, 7.4 ft-lb)**
- T3: 17 N·m (1.7 kgf-m, 12.5 ft-lb)**
- T4: 18 N·m (1.8 kgf-m, 13.3 ft-lb)**

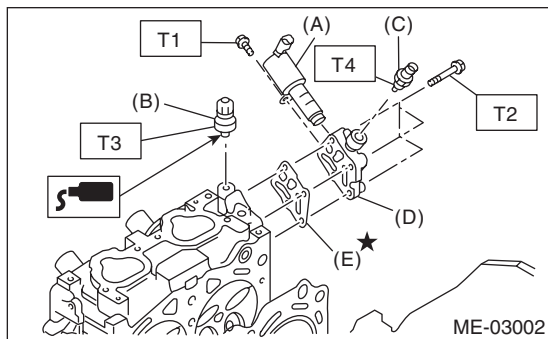

- (A) Oil switching solenoid valve
- (B) Variable valve lift diagnosis oil pressure switch
- (C) Oil temperature sensor
- (D) Oil switching solenoid valve holder
- (E) Gasket
- (F) Oil temperature sensor gasket

2. LH SIDE

Install in the reverse order of removal.

NOTE:

- Use a new gasket.
- Apply to the threads of the variable valve lift diagnosis oil pressure switch.
- Install the oil switching solenoid valve to the holder, then install it to the cylinder head.

Liquid gasket:

THREE BOND 1324 (Part No. 004403042)

Tightening torque:

- T1: 8 N·m (0.8 kgf-m, 5.9 ft-lb)**
- T2: 10 N·m (1.0 kgf-m, 7.4 ft-lb)**
- T3: 17 N·m (1.7 kgf-m, 12.5 ft-lb)**

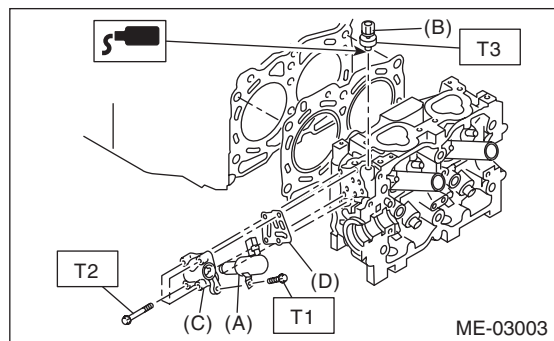

- (A) Oil switching solenoid valve
- (B) Variable valve lift diagnosis oil pressure switch
- (C) Oil switching solenoid valve holder
- (D) Gasket

23. Intake and Exhaust Valve

A: SPECIFICATION

Refer to "Cylinder Head" for removal and installation procedures of intake and exhaust valves. <Ref. to ME(H4SO)-58, REMOVAL, Cylinder Head.>
<Ref. to ME(H4SO)-58, INSTALLATION, Cylinder Head.>

Brought to you by Eris Studios
NOT FOR RESALE

24.Piston

A: SPECIFICATION

Refer to "Cylinder Block" for removal and installation procedures of pistons. <Ref. to ME(H4SO)-66, REMOVAL, Cylinder Block.> <Ref. to ME(H4SO)-71, INSTALLATION, Cylinder Block.>

Brought to you by Eris Studios
NOT FOR RESALE

25. Connecting Rod

A: SPECIFICATION

Refer to "Cylinder Block" for removal and installation procedures of connecting rod. <Ref. to ME(H4SO)-66, REMOVAL, Cylinder Block.> <Ref. to ME(H4SO)-71, INSTALLATION, Cylinder Block.>

Brought to you by Eris Studios
NOT FOR RESALE

26.Crankshaft

A: SPECIFICATION

Refer to "Cylinder Block" for removal and installation procedures of the crankshaft. <Ref. to ME(H4SO)-66, REMOVAL, Cylinder Block.> <Ref. to ME(H4SO)-71, INSTALLATION, Cylinder Block.>

Engine Trouble in General

MECHANICAL

27.Engine Trouble in General

A: INSPECTION

NOTE:

The "RANK" shown in the chart shows the possibilities of the cause of trouble in order from "Very often" to "Rarely".

A — Very often

B — Sometimes

C — Rarely

Symptoms	Problem parts etc.	Possible cause	RANK
1. Engine does not start.			
1) Starter does not turn.	Starter	Defective battery-to-starter harness	B
		Defective starter switch	C
		Defective inhibitor switch	C
		Defective starter	B
	Battery	Improper connection of terminal	A
		Run-down battery	A
		Defective charging system	B
	Friction	Seizure of crankshaft and connecting rod bearing	C
		Seized camshaft	C
Seized or stuck piston and cylinder		C	
2) Initial combustion does not occur.	Starter	Defective starter	C
	Engine control system <Ref. to EN(H4SO)(diag)-2, Basic Diagnostic Procedure.>		A
	Fuel line	Defective fuel pump and relay	A
		Clogged fuel line	A
		Lack of or insufficient fuel	B
	Timing belt	Degradation, etc.	B
		Defective timing	B
	Compression	Incorrect valve clearance	C
		Loosened spark plug or defective gasket	C
		Loosened cylinder head bolt or defective gasket	C
		Improper valve sealing	C
		Defective valve stem	C
		Worn or broken valve spring	B
Worn or stuck piston rings, cylinder and piston		C	
Incorrect valve timing		B	
Improper engine oil (low viscosity)	B		

Engine Trouble in General

MECHANICAL

Symptoms	Problem parts etc.	Possible cause	RANK
3) Initial combustion occurs.	Engine control system <Ref. to EN(H4SO)(diag)-2, Basic Diagnostic Procedure.>		A
	Intake system	Defective intake manifold gasket	B
		Defective throttle body gasket	B
	Fuel line	Defective fuel pump and relay	C
		Clogged fuel line	C
		Lack of or insufficient fuel	B
	Timing belt	Degradation, etc.	B
		Defective timing	B
	Compression	Incorrect valve clearance	C
		Loosened spark plug or defective gasket	C
		Loosened cylinder head bolt or defective gasket	C
		Improper valve sealing	C
		Defective valve stem	C
		Worn or broken valve spring	B
Worn or stuck piston rings, cylinder and piston		C	
Incorrect valve timing		B	
Improper engine oil (low viscosity)	B		
4) Engine stalls after initial combustion.	Engine control system <Ref. to EN(H4SO)(diag)-2, Basic Diagnostic Procedure.>		A
	Intake system	Loosened or cracked intake duct	B
		Loosened or cracked PCV hose	C
		Loosened or cracked vacuum hose	C
		Defective intake manifold gasket	B
		Defective throttle body gasket	B
		Dirty air cleaner element	C
	Fuel line	Clogged fuel line	C
		Lack of or insufficient fuel	B
	Timing belt	Degradation, etc.	B
		Defective timing	B
	Compression	Incorrect valve clearance	C
		Loosened spark plug or defective gasket	C
		Loosened cylinder head bolt or defective gasket	C
		Improper valve sealing	C
		Defective valve stem	C
		Worn or broken valve spring	B
		Worn or stuck piston rings, cylinder and piston	C
Incorrect valve timing		B	
Improper engine oil (low viscosity)	B		

Engine Trouble in General

MECHANICAL

Symptoms	Problem parts etc.	Possible cause	RANK
2. Rough idle and engine stall	Engine control system <Ref. to EN(H4SO)(diag)-2, Basic Diagnostic Procedure.>		A
	Intake system	Loosened or cracked intake duct	A
		Loosened or cracked PCV hose	A
		Loosened or cracked vacuum hose	A
		Defective intake manifold gasket	B
		Defective throttle body gasket	B
		Defective PCV valve	C
		Loosened oil filler cap	B
		Dirty air cleaner element	C
	Fuel line	Defective fuel pump and relay	C
		Clogged fuel line	C
		Lack of or insufficient fuel	B
	Timing belt	Defective timing	C
	Compression	Incorrect valve clearance	B
		Loosened spark plug or defective gasket	B
		Loosened cylinder head bolt or defective gasket	B
		Improper valve sealing	B
		Defective valve stem	C
		Worn or broken valve spring	B
		Worn or stuck piston rings, cylinder and piston	B
		Incorrect valve timing	A
	Lubrication system	Improper engine oil (low viscosity)	B
		Incorrect oil pressure	B
	Cooling system	Defective rocker cover gasket	C
		Overheating	C
	Others	Evaporative emission control system malfunction	A
		Stuck or damaged throttle valve	B

Engine Trouble in General

MECHANICAL

Symptoms	Problem parts etc.	Possible cause	RANK
3. Low output, hesitation and poor acceleration	Engine control system <Ref. to EN(H4SO)(diag)-2, Basic Diagnostic Procedure.>		A
	Intake system	Loosened or cracked intake duct	A
		Loosened or cracked PCV hose	A
		Loosened or cracked vacuum hose	B
		Defective intake manifold gasket	B
		Defective throttle body gasket	B
		Defective PCV valve	B
		Loosened oil filler cap	B
		Dirty air cleaner element	A
	Fuel line	Defective fuel pump and relay	B
		Clogged fuel line	B
		Lack of or insufficient fuel	C
	Timing belt	Defective timing	B
	Compression	Incorrect valve clearance	B
		Loosened spark plug or defective gasket	B
		Loosened cylinder head bolt or defective gasket	B
		Improper valve sealing	B
		Defective valve stem	C
		Worn or broken valve spring	B
		Worn or stuck piston rings, cylinder and piston	C
		Incorrect valve timing	A
	Improper engine oil (low viscosity)	B	
	Lubrication system	Incorrect oil pressure	B
	Cooling system	Overheating	C
		Over-cooling	C
	Others	Evaporative emission control system malfunction	A
	4. Surging	Engine control system <Ref. to EN(H4SO)(diag)-2, Basic Diagnostic Procedure.>	
Intake system		Loosened or cracked intake duct	A
		Loosened or cracked PCV hose	A
		Loosened or cracked vacuum hose	A
		Defective intake manifold gasket	B
		Defective throttle body gasket	B
		Defective PCV valve	B
		Loosened oil filler cap	B
		Dirty air cleaner element	B
Fuel line		Defective fuel pump and relay	B
		Clogged fuel line	B
		Lack of or insufficient fuel	C
Timing belt		Defective timing	B
Compression		Incorrect valve clearance	B
		Loosened spark plug or defective gasket	C
		Loosened cylinder head bolt or defective gasket	C
		Improper valve sealing	C
		Defective valve stem	C
		Worn or broken valve spring	C
		Worn or stuck piston rings, cylinder and piston	C
		Incorrect valve timing	A
Improper engine oil (low viscosity)		B	
Cooling system		Overheating	B
Others		Evaporative emission control system malfunction	C

Engine Trouble in General

MECHANICAL

Symptoms	Problem parts etc.	Possible cause	RANK
5. Engine does not return to idle.	Engine control system <Ref. to EN(H4SO)(diag)-2, Basic Diagnostic Procedure.>		A
	Intake system	Loosened or cracked vacuum hose	A
	Others	Stuck or damaged throttle valve	A
6. Dieseling (Run-on)	Engine control system <Ref. to EN(H4SO)(diag)-2, Basic Diagnostic Procedure.>		A
	Cooling system	Overheating	B
	Others	Evaporative emission control system malfunction	B
7. After burning in exhaust system	Engine control system <Ref. to EN(H4SO)(diag)-2, Basic Diagnostic Procedure.>		A
	Intake system	Loosened or cracked intake duct	C
		Loosened or cracked PCV hose	C
		Loosened or cracked vacuum hose	B
		Defective PCV valve	B
		Loosened oil filler cap	C
	Timing belt	Defective timing	B
	Compression	Incorrect valve clearance	B
		Loosened spark plug or defective gasket	C
		Loosened cylinder head bolt or defective gasket	C
		Improper valve sealing	B
		Defective valve stem	C
		Worn or broken valve spring	C
		Worn or stuck piston rings, cylinder and piston	C
		Incorrect valve timing	A
Lubrication system	Incorrect oil pressure	C	
Cooling system	Over-cooling	C	
Others	Evaporative emission control system malfunction	C	
8. Knocking	Engine control system <Ref. to EN(H4SO)(diag)-2, Basic Diagnostic Procedure.>		A
	Intake system	Loosened oil filler cap	B
	Belt	Defective timing	B
	Compression	Incorrect valve clearance	C
		Incorrect valve timing	B
	Cooling system	Overheating	A
9. Excessive engine oil consumption	Intake system	Loosened or cracked PCV hose	A
		Defective PCV valve	B
		Loosened oil filler cap	C
	Compression	Defective valve stem	A
		Worn or stuck piston rings, cylinder and piston	A
	Lubrication system	Loosened oil pump attaching bolts and defective gasket	B
		Defective oil filter seal	B
		Defective crankshaft oil seal	B
		Defective rocker cover gasket	B
		Loosened oil drain plug or defective gasket	B
	Loosened oil pan fitting bolts or defective oil pan	B	

Engine Trouble in General

MECHANICAL

Symptoms	Problem parts etc.	Possible cause	RANK	
10. Excessive fuel consumption	Engine control system <Ref. to EN(H4SO)(diag)-2, Basic Diagnostic Procedure.>		A	
	Intake system	Dirty air cleaner element	A	
	Timing belt	Defective timing	B	
	Compression	Incorrect valve clearance		B
		Loosened spark plug or defective gasket		C
		Loosened cylinder head bolt or defective gasket		C
		Improper valve sealing		B
		Defective valve stem		C
		Worn or broken valve spring		C
		Worn or stuck piston rings, cylinder and piston		B
		Incorrect valve timing		B
	Lubrication system	Incorrect oil pressure	C	
	Cooling system	Over-cooling	C	

28.Engine Noise

A: INSPECTION

Type of sound	Condition	Possible cause
Regular clicking sound	Sound increases as engine speed increases.	<ul style="list-style-type: none"> Valve mechanism is defective. Incorrect valve clearance Worn valve rocker Worn camshaft Broken valve spring
Heavy and dull clank	Oil pressure is low.	<ul style="list-style-type: none"> Worn crankshaft main bearing Worn connecting rod bearing (large end)
	Oil pressure is normal.	Damaged engine mounting
High-pitched clank (Spark knock)	Sound is noticeable when accelerating with an overload condition.	<ul style="list-style-type: none"> Ignition timing advanced Accumulation of carbon inside combustion chamber Wrong spark plug Improper gasoline
Clank when engine speed is 1,000 to 2,000 rpm	Sound is reduced when fuel injector connector of noisy cylinder is disconnected. (NOTE*)	<ul style="list-style-type: none"> Worn crankshaft main bearing Worn connecting rod bearing (large end)
Knocking sound when engine is operating under idling speed and engine is warm	Sound is reduced when fuel injector connector of noisy cylinder is disconnected. (NOTE*)	<ul style="list-style-type: none"> Worn cylinder liner and piston ring Broken or stuck piston ring Worn piston pin and hole at piston end of connecting rod
	Sound is not reduced if each fuel injector connector is disconnected in turn. (NOTE*)	<ul style="list-style-type: none"> Worn cam sprocket Worn camshaft journal bore in cylinder head assembly
Squeaky sound	—	Insufficient generator lubrication
Rubbing sound	—	Poor contact of generator brush and rotor
Gear scream when starting engine	—	<ul style="list-style-type: none"> Defective ignition starter switch Worn gear and starter pinion
Sound like polishing glass with a dry cloth	—	<ul style="list-style-type: none"> Loose drive belt Defective water pump shaft
Hissing sound	—	<ul style="list-style-type: none"> Insufficient compression Air leakage in air intake system, hose, connection or manifold
Timing belt noise	—	<ul style="list-style-type: none"> Loose timing belt Belt contacting with case/adjacent part
Valve noise	—	Incorrect valve clearance

NOTE*)

When disconnecting the fuel injector connector, the malfunction indicator light illuminates and DTC is stored in ECM memory. Therefore, perform the Clear Memory Mode <Ref. to EN(H4SO)(diag)-47, OPERATION, Clear Memory Mode.> and Inspection Mode <Ref. to EN(H4SO)(diag)-38, PROCEDURE, Inspection Mode.> after connecting the fuel injector connector.