

Brought to you by Eris Studios
NOT FOR RESALE

EMISSION CONTROL

(AUX. EMISSION CONTROL DEVICES)

SYSTEM OVERVIEW

EMISSION CONTROL (AUX. EMISSION CONTROL DEVICES)

1. System Overview

There are three emission control systems, which are as follows:

- Crankcase emission control system
- Exhaust emission control system
 - Catalytic converter
 - Air/fuel (A/F) control system
 - Ignition control system
- Evaporative emission control system
 - On-board refueling vapor recovery (ORVR) system

SYSTEM OVERVIEW

EMISSION CONTROL (AUX. EMISSION CONTROL DEVICES)

Item		Main components	Function	
Crankcase emission control system		Positive crankcase ventilation (PCV) valve	Draws blow-by gas into intake manifold from crankcase and burn it together with air-fuel mixture. Amount of blow-by gas to be drawn in is controlled by intake manifold pressure.	
Exhaust emission control system	Catalytic converter	Front	Catalytic converter	Oxidizes HC and CO contained in exhaust gases as well as reducing NOx.
		Rear		
	Air/fuel (A/F) control system		Engine control module (ECM)	Receives input signals from various sensors, compares signals with stored data, and emits a signal for optimal control of air-fuel mixture ratio.
			Front oxygen (A/F) sensor	Detects density of oxygen contained exhaust gases.
			Rear oxygen sensor	Detects density of oxygen contained in exhaust gases.
			Throttle position sensor	Detects throttle opening.
			Manifold absolute pressure sensor	Detects absolute pressure of intake manifold.
			Mass air flow and intake air temperature sensor	Detects amount of intake air.
				Detects the amount of intake air temperature inside the air cleaner case.
	Ignition control system		ECM	Receives various signals, compares signals with basic data stored in memory, and emits a signal for optimal control of ignition timing.
			Crankshaft position sensor	Detects engine speed (revolution).
			Camshaft position sensor	Detects reference signal for combustion cylinder discrimination.
			Engine coolant temperature sensor	Detects coolant temperature.
Knock sensor			Detects engine knocking.	
Evaporative emission control system		Canister	Absorbs evaporative gas that accumulates in fuel tank when engine stops, and releases it to combustion chambers for a complete burn when the engine is started. This prevents HC from being discharged into atmosphere.	
		Purge control solenoid valve	Receives a signal from ECM and controls purge of evaporative gas absorbed by canister.	
		Pressure control solenoid valve	Receives a signal from ECM and controls evaporative gas pressure in fuel tank.	
On-board refueling vapor recovery (ORVR) system		Vent valve	Opens a valve during refueling to let fuel vapor in the fuel tank flow to the canister. The system also closes the port to the canister when the fuel tank is full of fuel.	
		Drain valve	Closes the evaporation line by receiving a signal from ECM to check the evaporation gas leak.	

SCHEMATIC DIAGRAMS

EMISSION CONTROL (AUX. EMISSION CONTROL DEVICES)

2. Schematic Diagrams

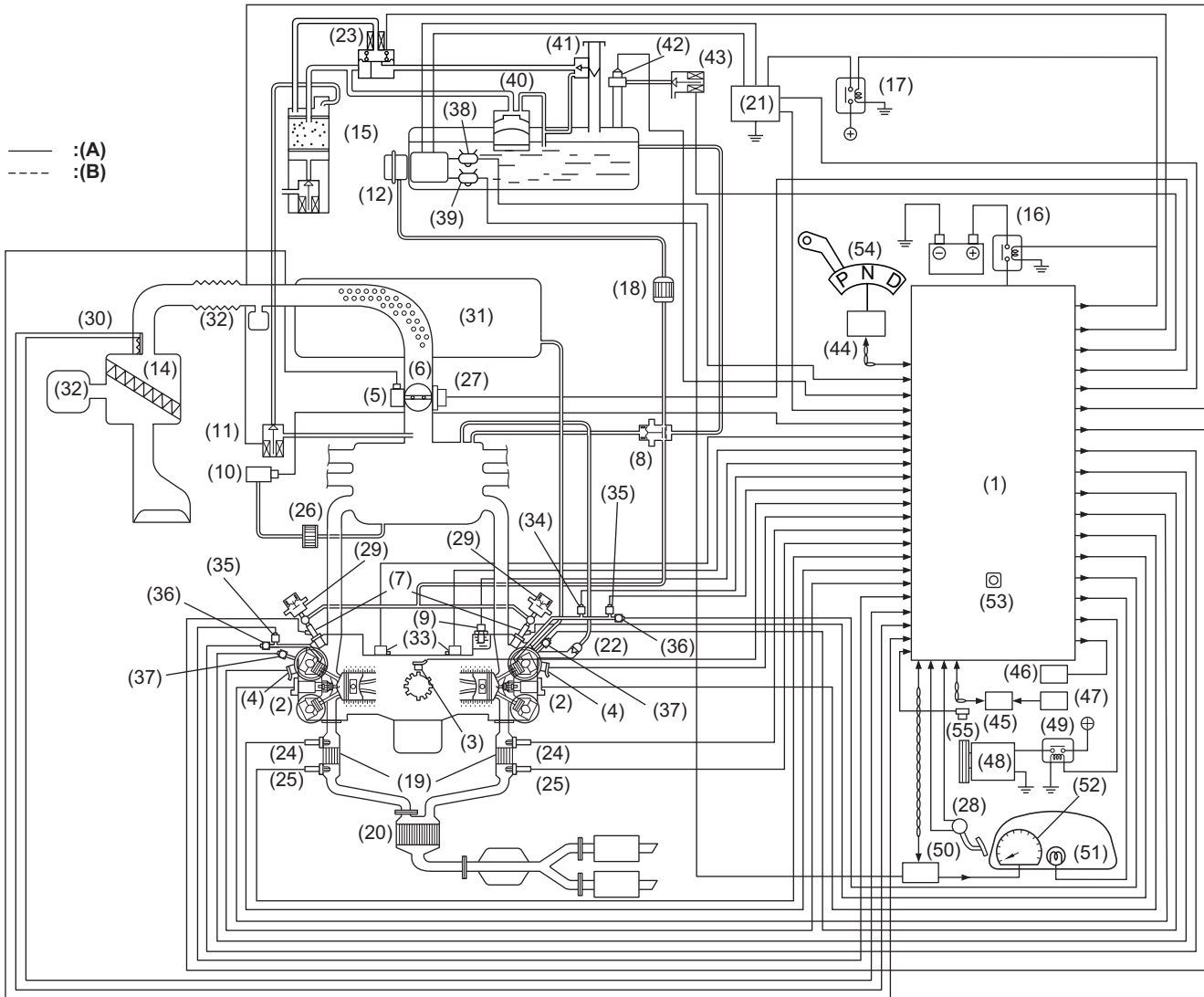

EC-02102

SCHEMATIC DIAGRAMS

EMISSION CONTROL (AUX. EMISSION CONTROL DEVICES)

- | | | |
|--|--|-------------------------------------|
| (1) Engine control module (ECM) | (20) Rear catalytic converter | (39) Fuel level sensor |
| (2) Ignition coil and igniter assembly | (21) Fuel pump controller | (40) Vent valve |
| (3) Crankshaft position sensor | (22) PCV valve | (41) Shut-off valve |
| (4) Camshaft position sensor | (23) Pressure control solenoid valve | (42) Fuel tank pressure sensor |
| (5) Throttle position sensor | (24) Front oxygen (A/F) sensor | (43) Fuel tank sensor control valve |
| (6) Electronic control throttle | (25) Rear oxygen sensor | (44) Transmission control module |
| (7) Fuel injector | (26) Air filter | (45) ABS/VDC control module |
| (8) Pressure regulator | (27) Electronic control throttle motor | (46) Data link connector |
| (9) Engine coolant temperature sensor | (28) Accelerator pedal position sensor | (47) Vehicle speed signal |
| (10) Manifold absolute pressure sensor | (29) Fuel damper | (48) A/C compressor |
| (11) Purge control solenoid valve | (30) Mass air flow and intake air temperature sensor | (49) A/C relay |
| (12) Fuel pump | (31) Air intake chamber | (50) Body integrated unit |
| (13) Fuel tank | (32) Resonator | (51) Malfunction indicator light |
| (14) Air cleaner element | (33) Knock sensor | (52) Tachometer |
| (15) Canister | (34) Oil temperature sensor | (53) Atmospheric pressure sensor |
| (16) Ignition relay | (35) Variable valve lift diagnosis oil pressure switch | (54) Neutral switch |
| (17) Fuel pump relay | (36) Oil switching solenoid valve | (55) A/C rotation lock sensor |
| (18) Fuel filter | (37) Oil flow control solenoid valve | (A) Electrical wiring |
| (19) Front catalytic converter | (38) Fuel temperature sensor | (B) Control piping |

CRANKCASE EMISSION CONTROL SYSTEM

EMISSION CONTROL (AUX. EMISSION CONTROL DEVICES)

3. Crankcase Emission Control System

The positive crankcase ventilation (PCV) system prevents air pollution that will be caused by blow-by gas being emitted from the crankcase.

The system consists of rocker covers with fresh air inlet, connecting hoses, a PCV valve and a chamber.

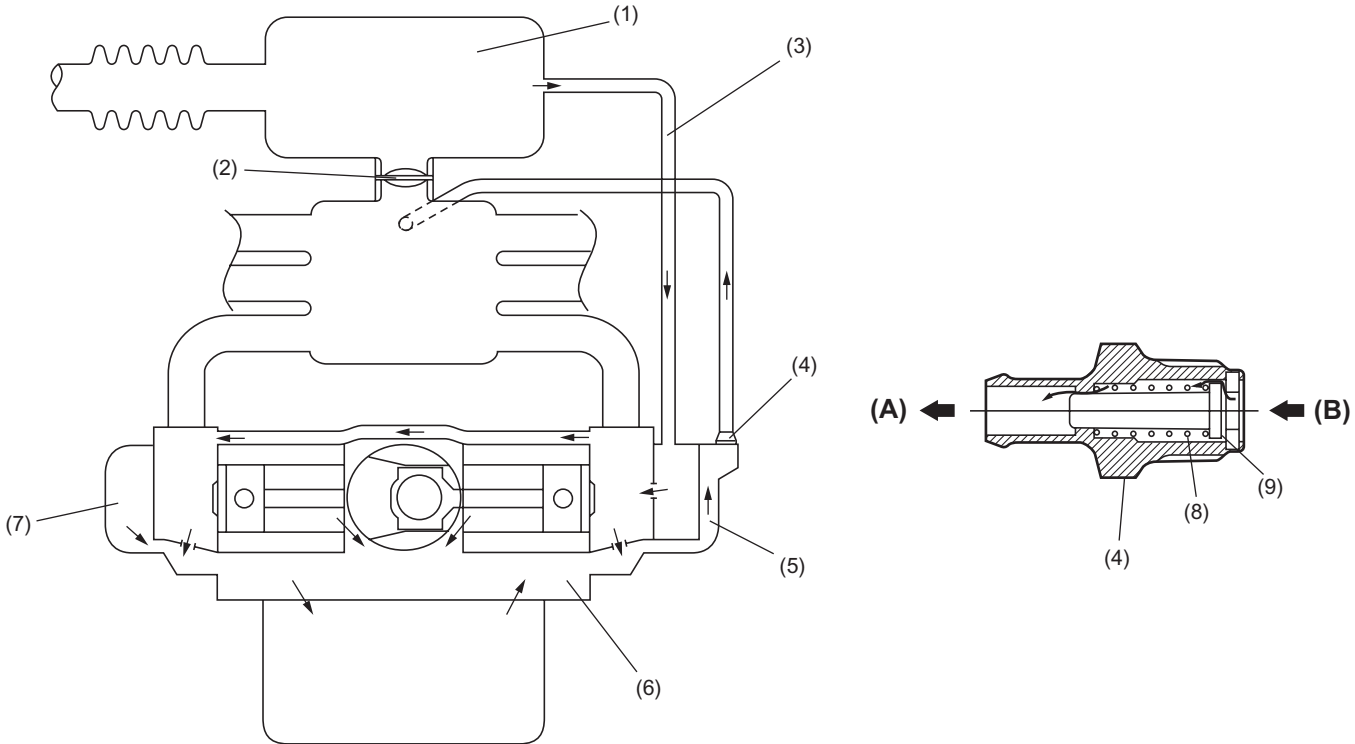

EC-02036

- (1) Air intake chamber
- (2) Electronic control throttle
- (3) Connecting hose
- (4) PCV valve
- (5) Rocker cover LH

- (6) Crankcase
- (7) Rocker cover RH
- (8) Spring
- (9) Valve

- (A) To intake manifold
- (B) Blow-by gas

4. Catalytic Converter

- The basic materials of the three-way catalytic converter are platinum (Pt), rhodium (Rh) and palladium (Pd), and a thin coat of their mixture is applied onto honeycomb or porous ceramics of an oval or round shape (carrier). To avoid damaging the catalytic converter, only unleaded gasoline should be used.
- The catalytic converter reduces HC, CO and NO_x in exhaust gases through chemical reactions (oxidation and reduction). These harmful components are reduced most efficiently when their concentrations are in a certain balance. These concentrations vary with the air-fuel ratio. The ideal air-fuel ratio for reduction of these components is the stoichiometric ratio.
- Therefore, the air-fuel ratio needs to be controlled to around the stoichiometric ratio to purify the exhaust gases most efficiently.

AIR/FUEL (A/F) CONTROL SYSTEM

EMISSION CONTROL (AUX. EMISSION CONTROL DEVICES)

5. Air/fuel (A/F) Control System

- The air/fuel (A/F) control system makes a correction to the basic fuel injection duration in accordance with the signals from the front oxygen (A/F) sensor so that the stoichiometric ratio is maintained, thus ensuring most effective exhaust gas purification by the three-way catalytic converter. Different basic fuel injection durations are preset for various engine speeds and loads, as well as the amount of intake air.
- This system also has a learning control function which stores the corrected data in relation to the basic fuel injection in the memory map. This allows an appropriate air-fuel ratio correction to be added automatically in quick response to any situation that requires such an effect. Thus, the air-fuel ratio is optimally maintained under various conditions while purifying exhaust gases most effectively, improving driving performance and compensating for changes in sensors' performance over time.

AIR/FUEL (A/F) CONTROL SYSTEM

EMISSION CONTROL (AUX. EMISSION CONTROL DEVICES)

MEMO

IGNITION CONTROL SYSTEM

EMISSION CONTROL (AUX. EMISSION CONTROL DEVICES)

6. Ignition Control System

- The ignition system is controlled by the ECM.

The ECM monitors the operating condition of the engine using the signals from the sensors and switches shown below and determines the ignition timing most appropriate for each engine operating condition. Then it sends a signal to the igniter, commanding generation of a spark at that timing.

- The ECM uses a preprogrammed map for a “closed-loop” control which provides its ignition timing control with excellent transient characteristics, i.e., highly responsive ignition timing control.

IGNITION CONTROL SYSTEM

EMISSION CONTROL (AUX. EMISSION CONTROL DEVICES)

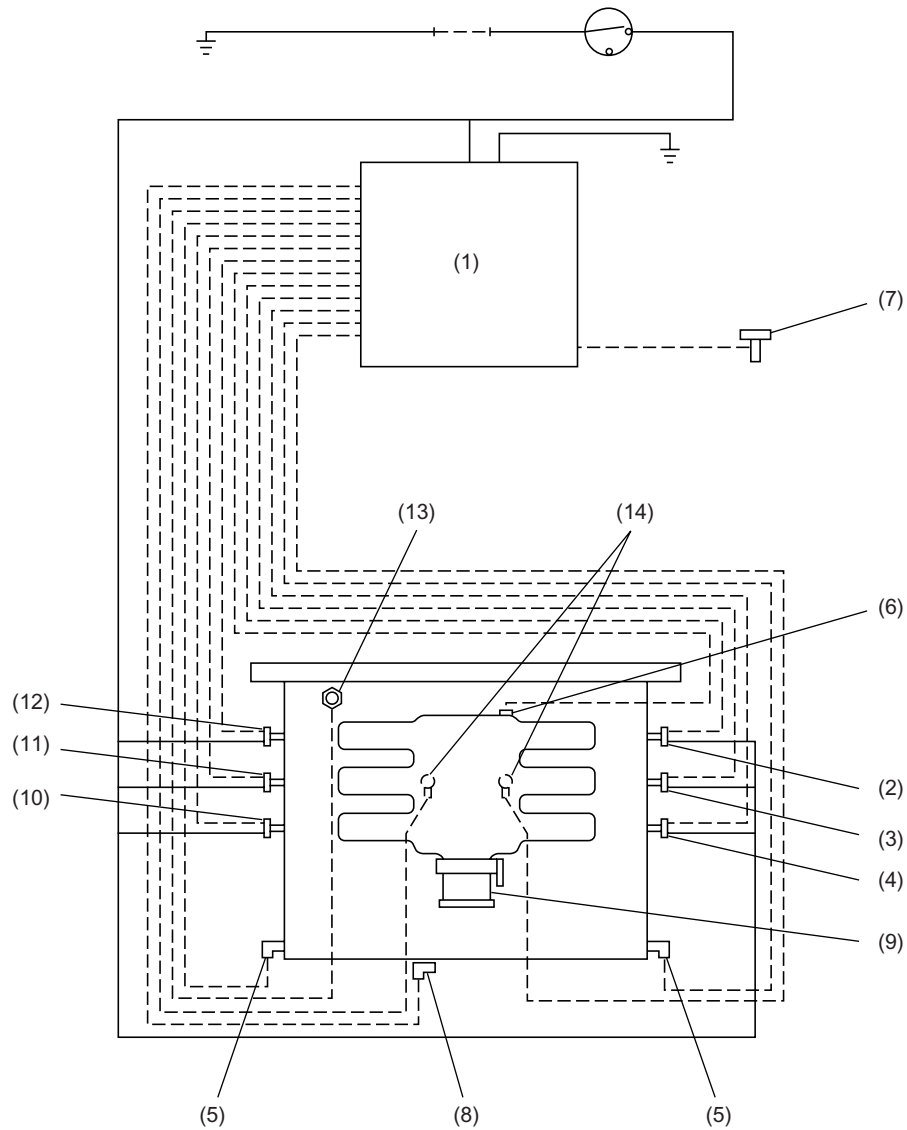

EC-02037

- | | |
|---|--|
| (1) ECM | (8) Crankshaft position sensor |
| (2) #1 ignition coil | (9) Electronic control throttle |
| (3) #3 ignition coil | (10) #6 ignition coil |
| (4) #5 ignition coil | (11) #4 ignition coil |
| (5) Camshaft position sensor | (12) #2 ignition coil |
| (6) Manifold absolute pressure sensor | (13) Engine coolant temperature sensor |
| (7) Mass air flow and intake air temperature sensor | (14) Knock sensor |

EVAPORATIVE EMISSION CONTROL SYSTEM

EMISSION CONTROL (AUX. EMISSION CONTROL DEVICES)

7. Evaporative Emission Control System

A: GENERAL

- The evaporative emission control system prevents fuel vapors from escaping into atmosphere. This system includes a canister, purge control solenoid valve, fuel cut valve, and the lines connecting them.
- Fuel vapor in the fuel tank is introduced into the canister through the evaporation line, and are absorbed by activated carbon in it. The fuel cut valve is also incorporated in the fuel tank line.
- The purge control solenoid valve is controlled optimally by the ECM according to the engine condition.
- The pressure control solenoid valve incorporated in the fuel tank evaporation line regulates the pressure/vacuum in the fuel tank under the control of the ECM which uses the signal from the fuel tank pressure sensor.

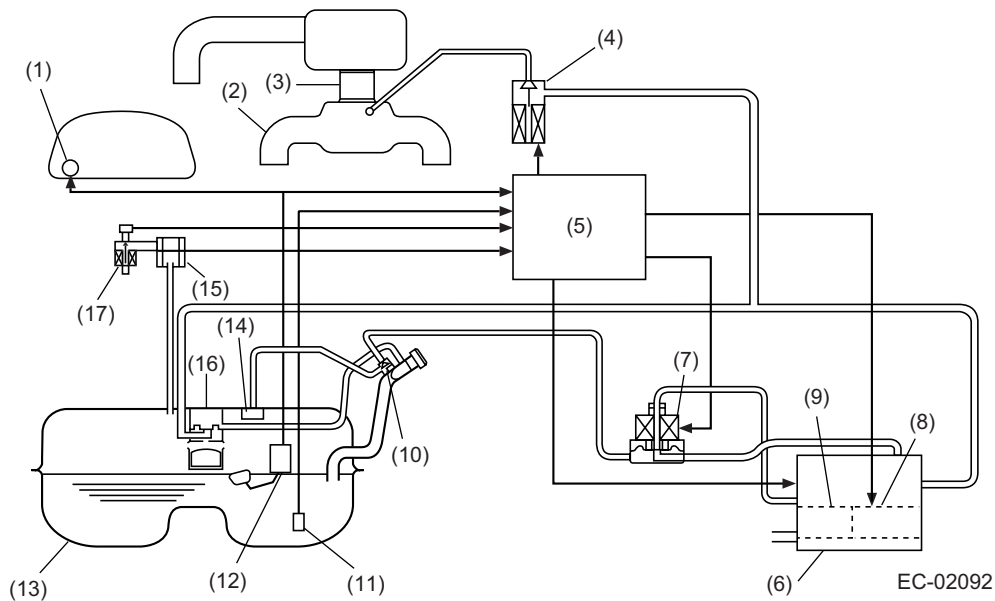

- | | | |
|----------------------------------|-------------------------------------|-------------------------------------|
| (1) Fuel gauge | (7) Pressure control solenoid valve | (13) Fuel tank |
| (2) Intake manifold | (8) Drain valve | (14) Fuel cut valve |
| (3) Throttle body | (9) Drain filter | (15) Fuel tank pressure sensor |
| (4) Purge control solenoid valve | (10) Shut-off valve | (16) Vent valve |
| (5) Engine control module (ECM) | (11) Fuel temperature sensor | (17) Fuel tank sensor control valve |
| (6) Canister | (12) Fuel level sensor | |

B: FUEL CUT VALVE

The fuel cut valve is incorporated in the fuel tank. The rising level of the fuel in the fuel tank causes the float to move up and close the cap hole so that no fuel can enter the evaporation line.

EVAPORATIVE EMISSION CONTROL SYSTEM

EMISSION CONTROL (AUX. EMISSION CONTROL DEVICES)

C: FUEL TANK CAP

- The fuel tank cap is of a quick lock type and can be opened or closed in 1/4 of a full turn.
- The fuel tank cap has a relief valve, which prevents development of vacuum in the fuel tank in the event of a problem with the fuel vapor line.
- When there is no problem with the fuel vapor line, the filler pipe is sealed at the portion (A) and by the seal pressed against the filler pipe end. If vacuum develops in the fuel tank, the atmospheric pressure forces the spring down to open the valve; consequently outside air flows into the fuel tank, thus controlling the inside pressure.

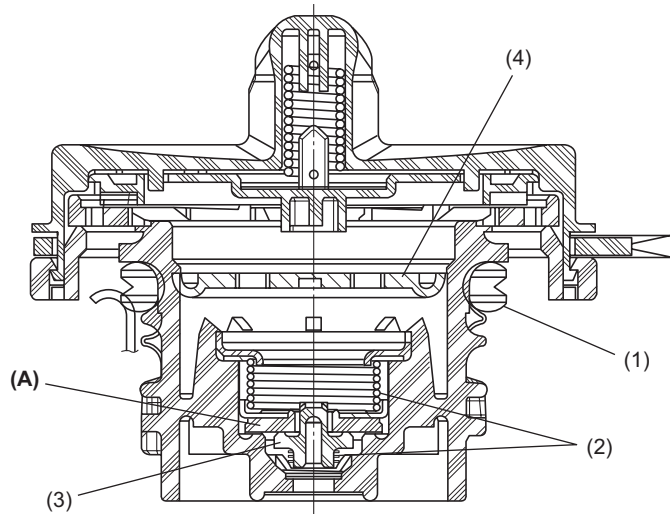

EC-02109

- (1) Seal
(2) Spring

- (3) Valve
(4) Filter

EVAPORATIVE EMISSION CONTROL SYSTEM

EMISSION CONTROL (AUX. EMISSION CONTROL DEVICES)

D: CANISTER

The canister incorporates a drain valve and a drain filter.

The charcoal filled in the canister temporarily stores fuel vapors. When the purge control solenoid valve is opened by a signal from the ECM, the external fresh air entering the canister carries the fuel vapors into the collector chamber.

The drain filter is installed at the air inlet port of the drain valve. It cleans the air taken in the canister through the drain valve.

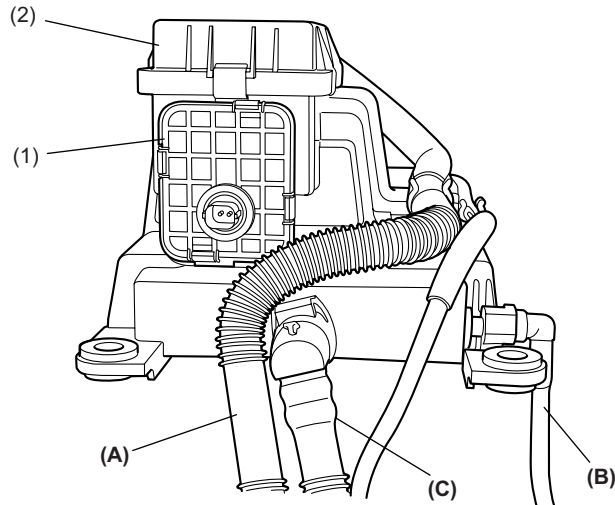

EC-02093

- (1) Drain valve
- (2) Drain filter

- (A) Air
- (B) To pressure control solenoid valve
- (C) From fuel tank

EVAPORATIVE EMISSION CONTROL SYSTEM

EMISSION CONTROL (AUX. EMISSION CONTROL DEVICES)

E: PURGE CONTROL SOLENOID VALVE

The purge control solenoid valve is on the evaporation line between the canister and intake manifold. It is installed at the underside of intake manifold.

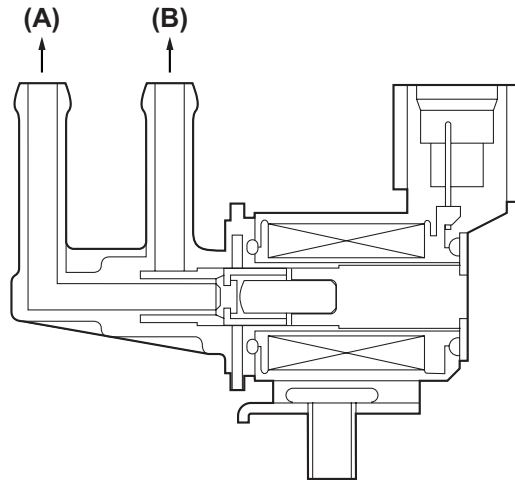

EC-00237

- (A) To canister
- (B) To intake manifold

EVAPORATIVE EMISSION CONTROL SYSTEM

EMISSION CONTROL (AUX. EMISSION CONTROL DEVICES)

F: PRESSURE CONTROL SOLENOID VALVE

The fuel tank pressure control solenoid valve is located in the evaporation line between the shut-off valve on fuel filler pipe and the fuel tank. It adjusts the fuel tank inside pressure under the control of the ECM.

When the tank inside pressure becomes higher than the atmospheric pressure, the valve is opened allowing fuel vapors to be introduced into the canister.

On the other hand, when the tank inside pressure becomes lower than the atmospheric pressure, external air is taken from the drain valve into the canister.

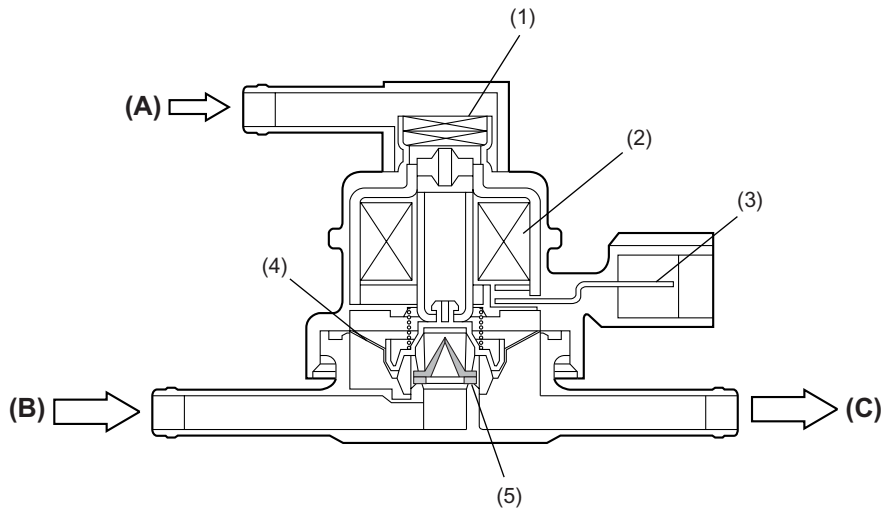

EC-00026

- | | |
|------------------------|--------------------------|
| (1) Filter | (A) Atmospheric pressure |
| (2) Coil | (B) From shut-off valve |
| (3) Connector terminal | (C) To fuel tank |
| (4) Diaphragm | |
| (5) Valve | |

G: VENT VALVE

The vent valve is located inside of the fuel tank. During filling the fuel tank, fuel vapors are introduced into the canister through the vent valve.

When the fuel vapor pressure becomes higher than the atmospheric pressure and overcomes the spring force which is applied to the back side of the diaphragm, the port toward the canister is opened. The vent valve also has a float which rises and block the port toward the canister when the fuel is full.

EVAPORATIVE EMISSION CONTROL SYSTEM

EMISSION CONTROL (AUX. EMISSION CONTROL DEVICES)

H: SHUT-OFF VALVE

The shut-off valve is located at the top of the fuel filler pipe. When a filler gun is inserted into the filler pipe, the shut-off valve closes the evaporation line.

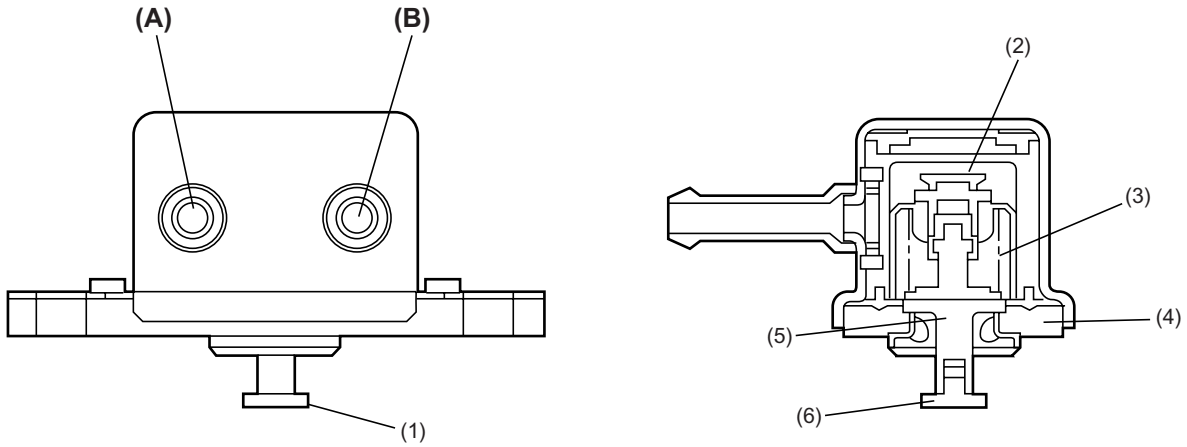

EC-00029

- (1) Pin
- (2) Valve
- (3) Spring
- (4) Plate
- (5) Shaft
- (6) Pin

- (A) To canister
- (B) To fuel tank

EVAPORATIVE EMISSION CONTROL SYSTEM

EMISSION CONTROL (AUX. EMISSION CONTROL DEVICES)

I: FUEL TANK SENSOR CONTROL VALVE

The fuel tank sensor control valve is installed on the top of the fuel tank and its one end is connected to the fuel tank pressure sensor while its other end is open to the atmosphere.

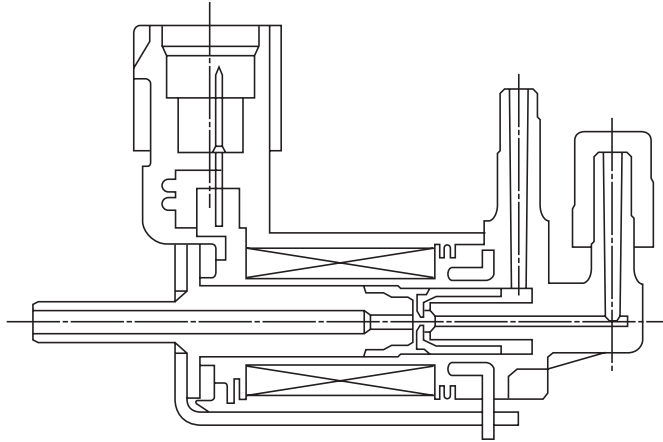

EC-00031

EVAPORATIVE EMISSION CONTROL SYSTEM

EMISSION CONTROL (AUX. EMISSION CONTROL DEVICES)

J: FUEL TANK PRESSURE SENSOR

The fuel tank pressure sensor is installed on the top of the fuel tank and measures the pressure in the fuel tank.

The measured pressure is converted into an electrical signal and sent to the ECM for diagnosis of the evaporative emission control system.

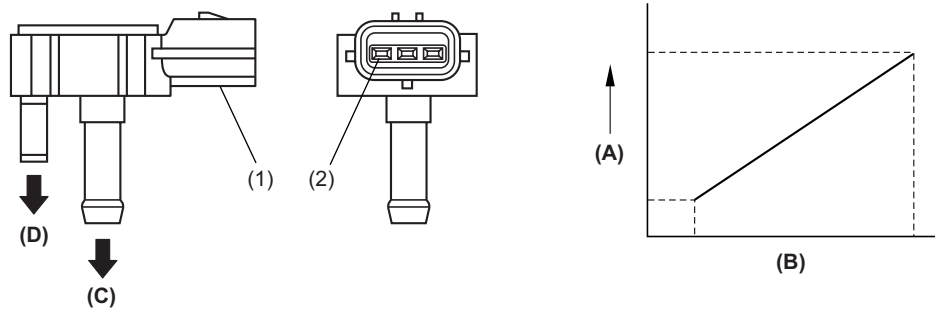

EC-02110

- (1) Connector
- (2) Terminal

- (A) Output voltage
- (B) Input pressure
- (C) To fuel tank
- (D) To fuel tank sensor control valve

ON-BOARD REFUELING VAPOR RECOVERY (ORVR) SYSTEM

EMISSION CONTROL (AUX. EMISSION CONTROL DEVICES)

8. On-board Refueling Vapor Recovery (ORVR) System

A: GENERAL

The on-board refueling vapor recovery system allows the fuel vapors in the fuel tank to be introduced directly into the canister through the vent valve when the fuel tank inside pressure increases as a result of refueling.

The diagnosis of the system is performed by monitoring the fuel tank inside pressure data from the fuel tank pressure sensor while forcibly closing the drain valve.

B: OPERATION

- While driving

Since the back side of the diaphragm in the pressure control solenoid valve is open to the atmosphere, the diaphragm is held pressed by the atmospheric pressure in the position where only the external air is introduced into the canister. When the fuel vapor pressure acting on the other side of the diaphragm increases and overcomes the atmospheric pressure, it pushes the diaphragm and opens the port through which the fuel vapors make their way to the canister.

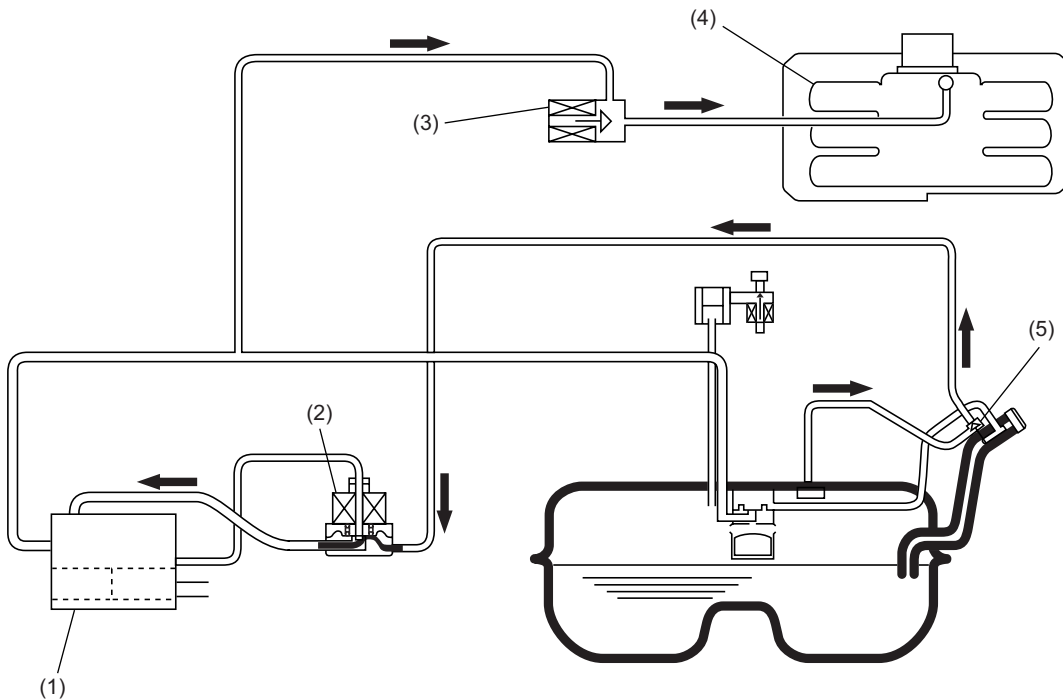

EC-02103

- | | |
|-------------------------------------|--------------------------|
| (1) Canister | (4) Intake manifold |
| (2) Pressure control solenoid valve | (5) Shut-off valve: Open |
| (3) Purge control solenoid valve | |

ON-BOARD REFUELING VAPOR RECOVERY (ORVR) SYSTEM

EMISSION CONTROL (AUX. EMISSION CONTROL DEVICES)

- While refueling

As the fuel enters the fuel tank, the tank inside pressure increases. When the inside pressure becomes higher than the atmospheric pressure, the port of the vent valve opens, allowing the fuel vapors to be introduced into the canister through the vent line. The fuel vapors are absorbed by charcoal in the canister, so the air discharged from the drain valve contains no fuel. When a filler gun is inserted, the shut-off valve closes the evaporation line.

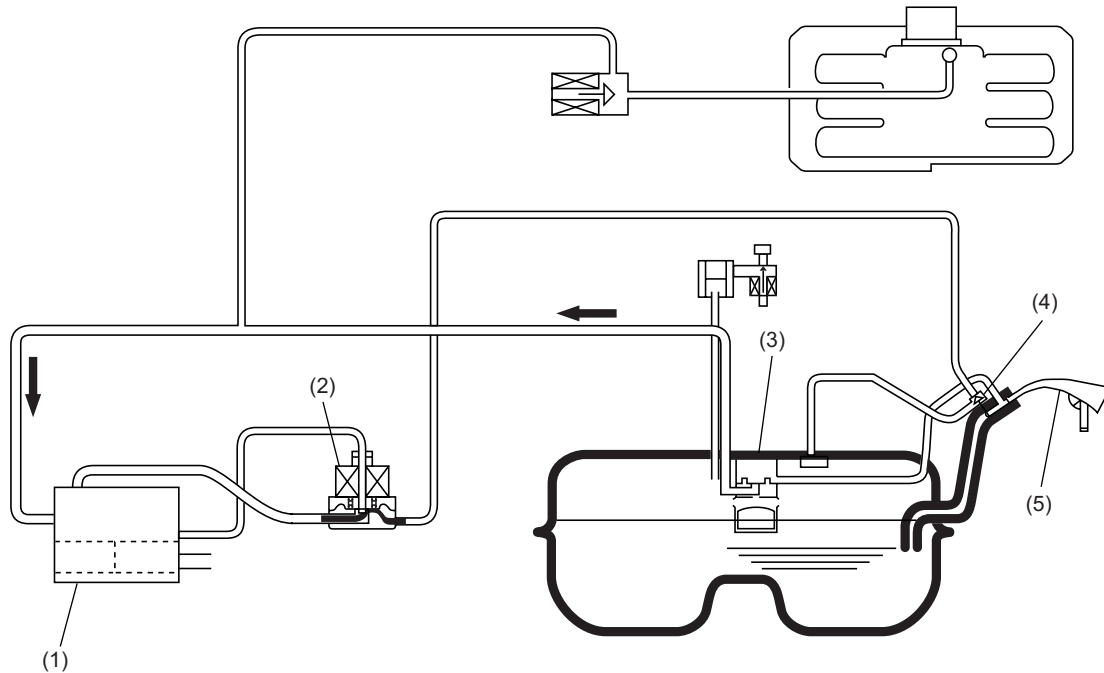

EC-02104

- | | |
|-------------------------------------|----------------------------|
| (1) Canister | (4) Shut-off valve: Closed |
| (2) Pressure control solenoid valve | (5) Filler gun |
| (3) Vent valve | |

VACUUM CONNECTIONS

EMISSION CONTROL (AUX. EMISSION CONTROL DEVICES)

9. Vacuum Connections

The hose and pipe connections of the intake manifold and other related parts are as shown in the illustration.

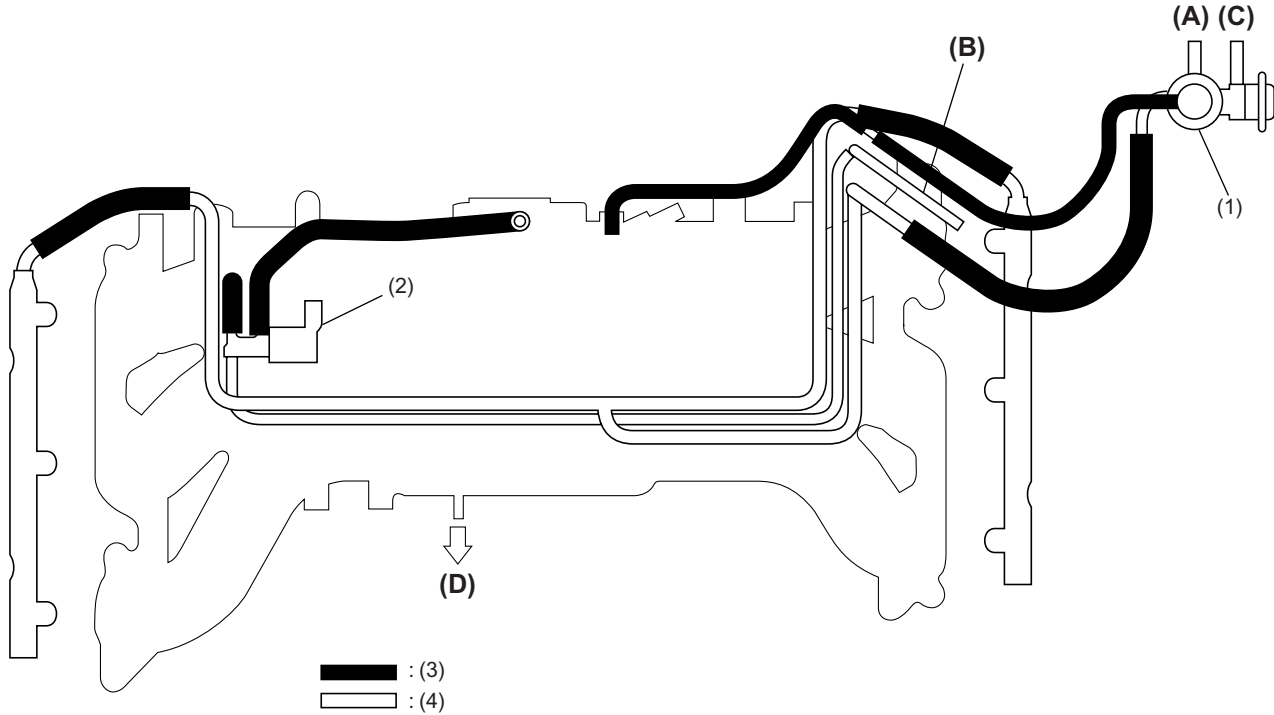

EC-02039

- (1) Pressure regulator
- (2) Purge control solenoid valve
- (3) Hose
- (4) Pipe

- (A) Delivery line
- (B) Fuel evaporation line
- (C) Return line
- (D) Front of vehicle