

Brought to you by Eris Studios
NOT FOR RESALE

IGNITION

1. Ignition Coil

The engine uses a direct ignition system with one ignition coil mounted for each cylinder.

The secondary terminal of the ignition coil is in contact with the spark plug terminal. Since no spark plug cable is used, secondary voltage drop, short circuit at connections, or other problems that are inherent in a system using spark plug cables do not occur. The result is high reliability.

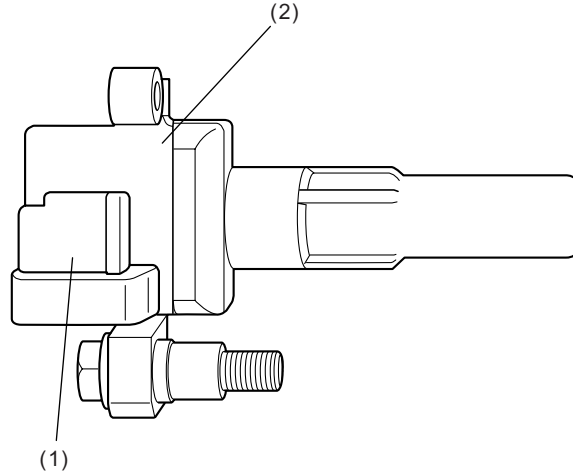

IG-00040

(1) Connector

(2) Ignition coil

2. Spark Plug

The spark plug has an iridium tipped electrode. The thread diameter is 14 mm (0.551 in) and the gap is controlled to a value between 0.7 and 0.8 mm (0.028 and 0.031 in).

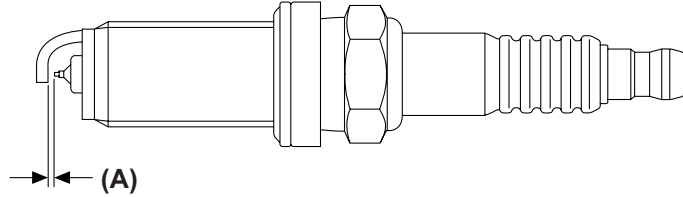

IG-02008

(A) Gap: 0.7 — 0.8 mm (0.028 — 0.031 in)