

7. Full Wheel Cap

A: REMOVAL

Pry off the full wheel cap with a wheel cap remover inserted between openings in the cap.

B: INSTALLATION

Align the valve hole in the wheel cap with the valve on the wheel and secure the wheel cap by tapping four points by hand.

8. Steel Wheel and Tire

- 1) Deformation or damage on the rim can cause air leakage. Check the rim flange for deformation, crack, or damage, and repair or replace as necessary.
- 2) Take stone, glass, nail etc. off the tread groove.

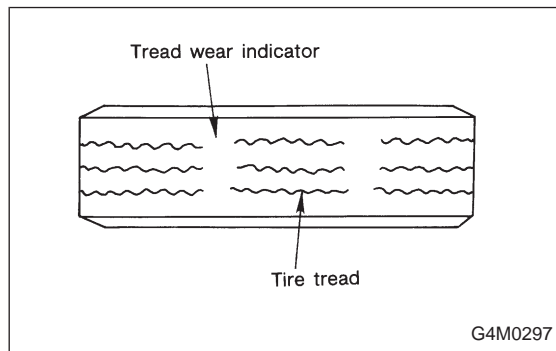

3) Replace tire:

- when large crack on side wall, damage or crack on tread is found.
- when the "tread wear indicator" appears as a solid band across the tread.

CAUTION:

- When replacing a tire, make sure to use only the same size, construction and load range as originally installed.
- Avoid mixing radial, belted bias or bias tires on the vehicle.

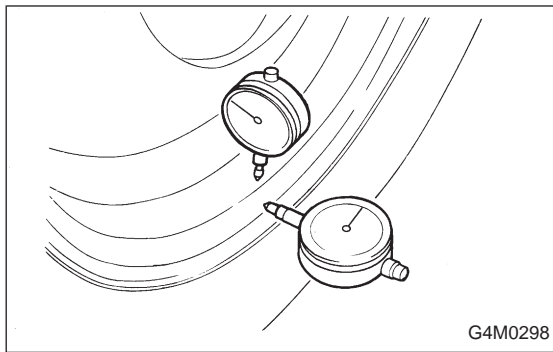

G4M0298

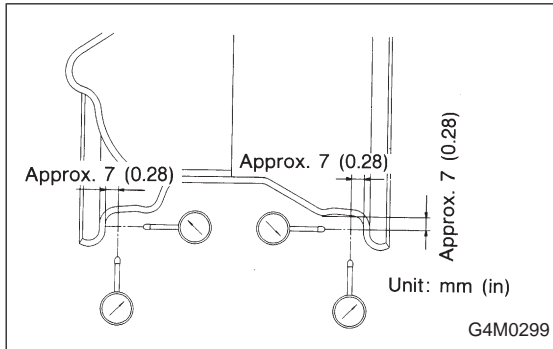

G4M0299

A: INSPECTION OF WHEEL RUNOUT

- 1) Jack-up vehicle until wheels clear the floor.
- 2) Slowly rotate wheel to check rim “runout” using a dial gauge.

	Axial runout limit	Radial runout limit
Steel wheel	1.5 mm (0.059 in)	
Aluminum wheel	1.0 mm (0.039 in)	

- 3) If rim runout exceeds specifications, remove tire from rim and check runout while attaching dial gauge to positions shown in figure.
- 4) If measured runout still exceeds specifications, replace the wheel.

9. Aluminum Wheel

A: INSPECTION

Inspection for aluminum wheels is basically the same as the one for steel wheels. However, check the rim flange for cracks or damage, and replace (not repair) aluminum wheel if air leakage is found.

B: PRECAUTIONS

Aluminum wheels are easily scratched. To maintain their appearance and safety, do the following:

- 1) Do not damage aluminum wheels during removal, disassembly, installation, wheel balancing, etc. After removing aluminum wheels, place them on a rubber mat, etc.
- 2) While vehicle is being driven, be careful not to ride over sharp obstacles or allow aluminum wheels to contact the shoulder of the road.
- 3) When installing tire chain, be sure to install it properly not to have a slack; otherwise it may hit wheel while driving.
- 4) When washing aluminum wheel, use neutral synthetic detergent and water. Avoid using the cleanser including abrasive, hard brushes or an automatic car washer.