

3. OPERATION OF SHIFT SELECTOR LEVER

WARNING:

Stop the engine while checking operation of selector lever.

- 1) Check that selector lever does not move from “N” to “R” without pushing the button.
- 2) Check that selector lever does not move from “R” to “P” without pushing the button.
- 3) Check that selector lever does not move from “P” to “R” without pushing the button.
- 4) Check that selector lever does not move from “3” to “2” without pushing the button.

3. Electrical Components Location

1. SENSOR AND CONTROL MODULE

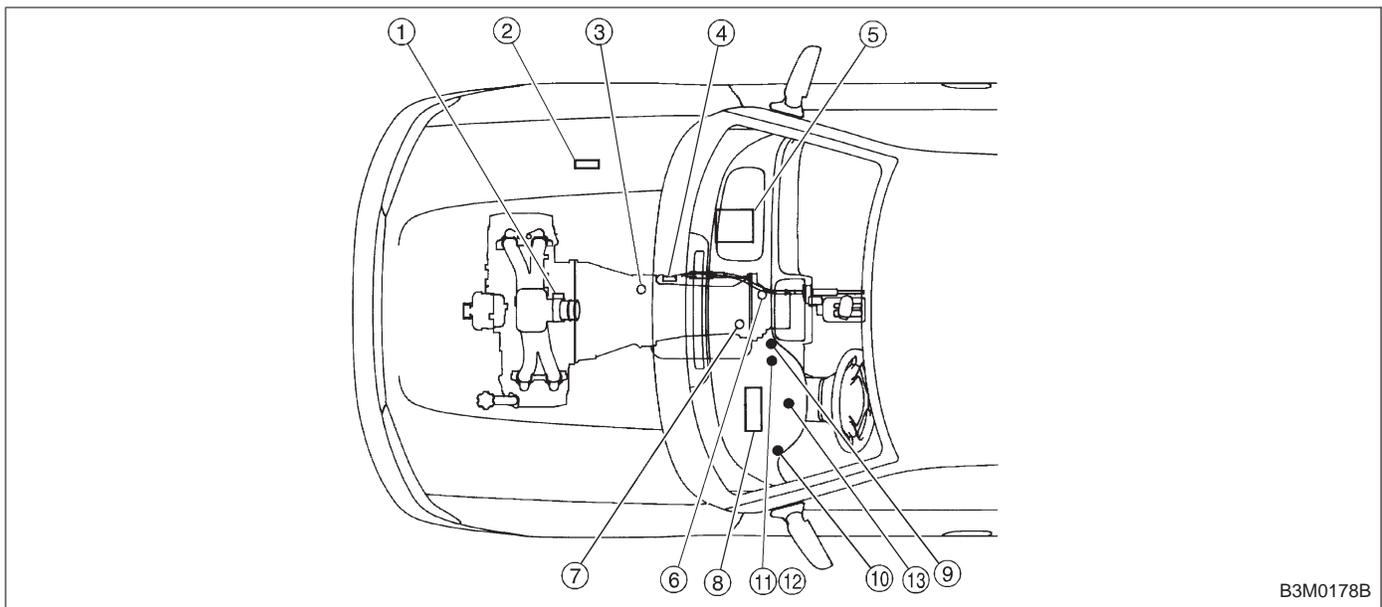

- | | |
|---|--|
| <ul style="list-style-type: none"> ① Throttle position sensor ② Dropping resistor ③ Vehicle speed sensor 2 ④ Inhibitor switch ⑤ ECM ⑥ Vehicle speed sensor 1 (AWD) ⑦ Vehicle speed sensor 1 (FWD) ⑧ TCM | <ul style="list-style-type: none"> ⑨ Data link connector (for Subaru select monitor only) ⑩ Data link connector (for Subaru select monitor and OBD-II general scan tool) ⑪ Diagnosis connector ⑫ Diagnosis terminal ⑬ AT OIL TEMP indicator light (AT diagnostic indicator light) |
|---|--|

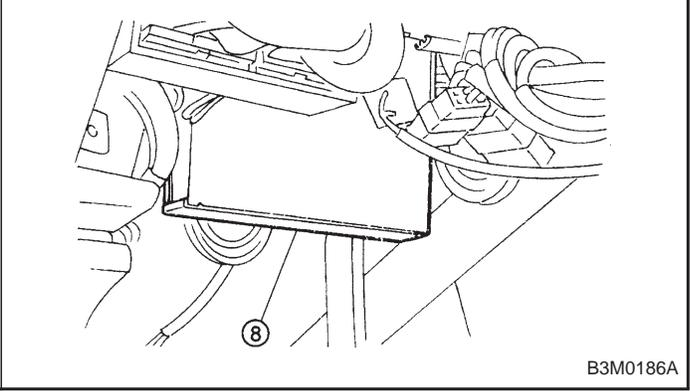
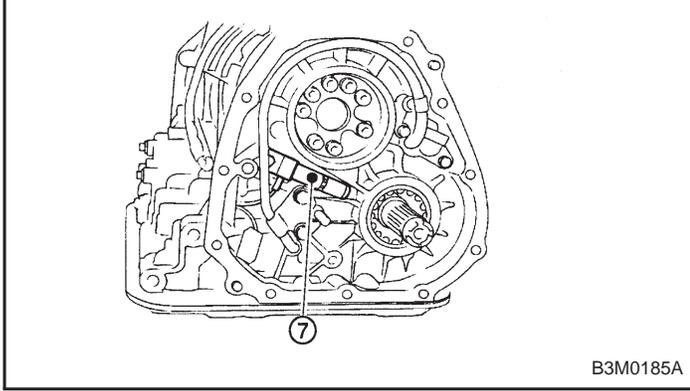
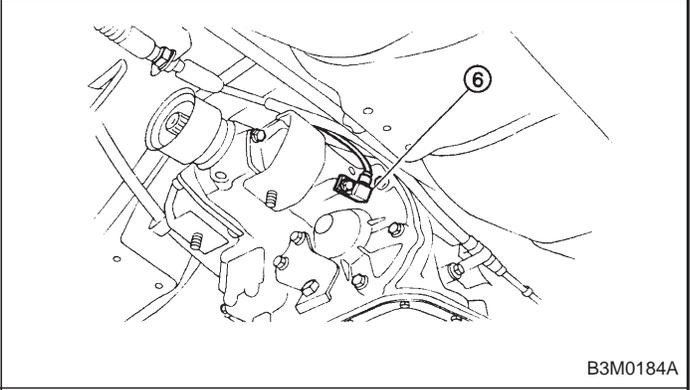
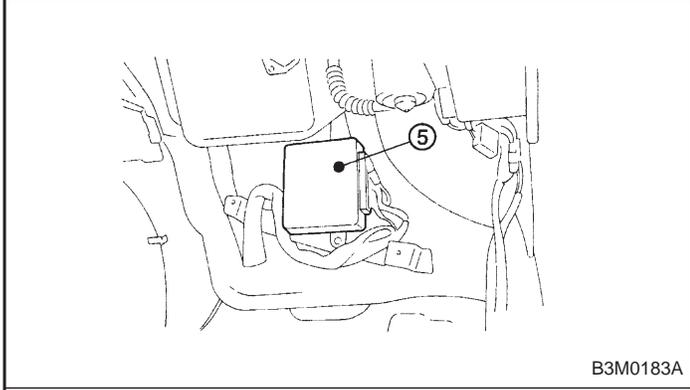
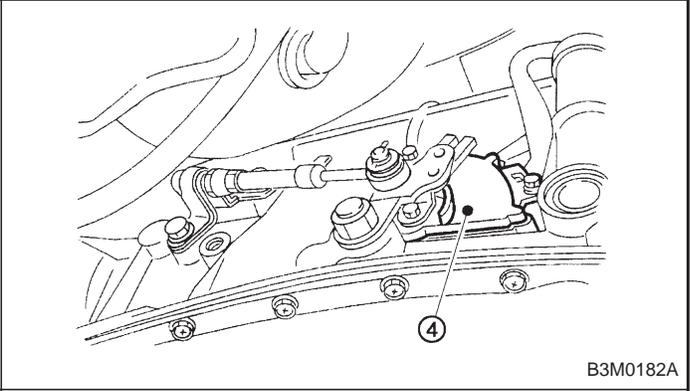
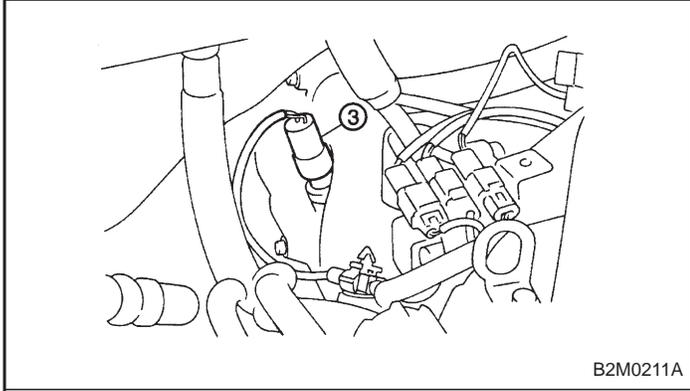
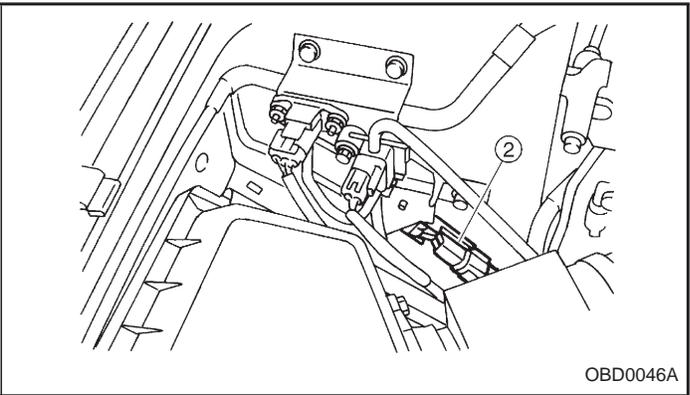
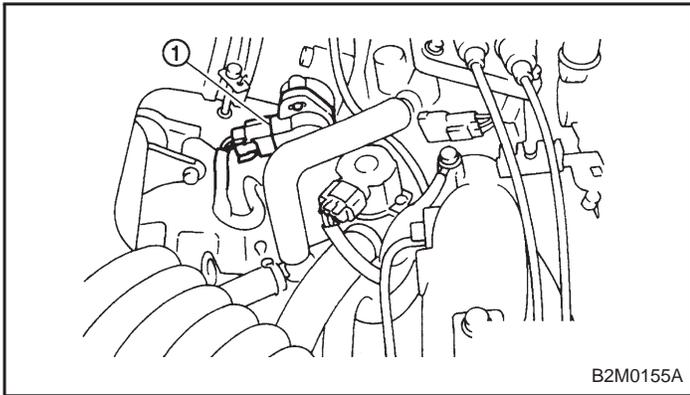

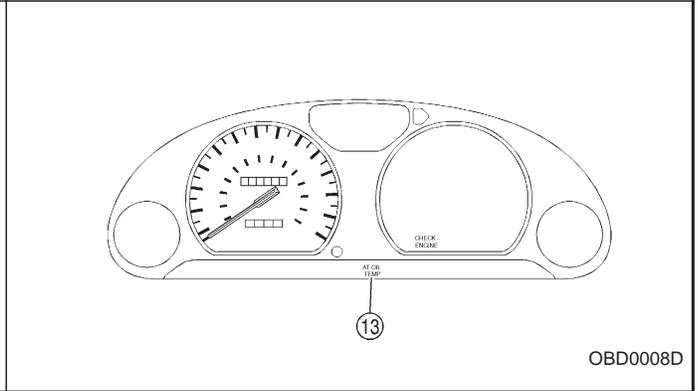
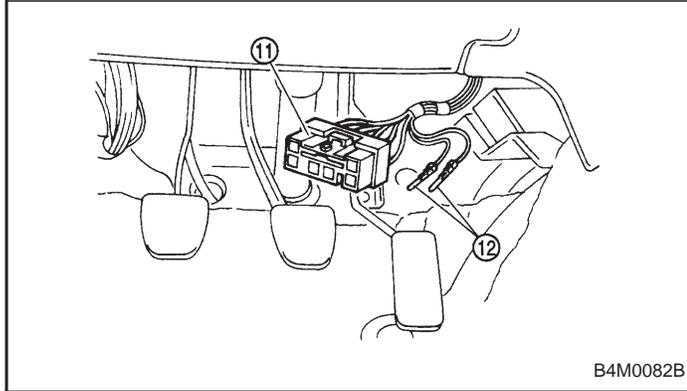
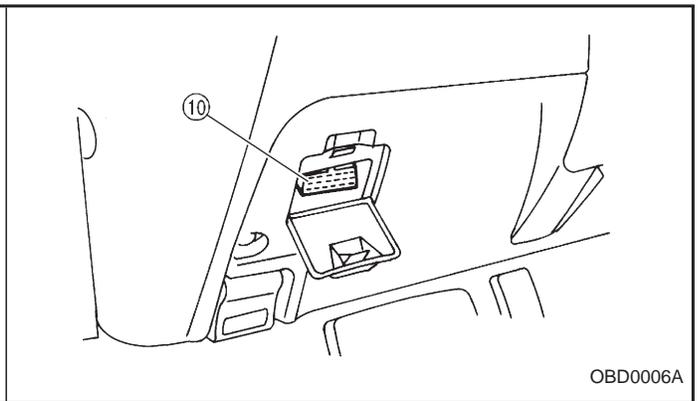
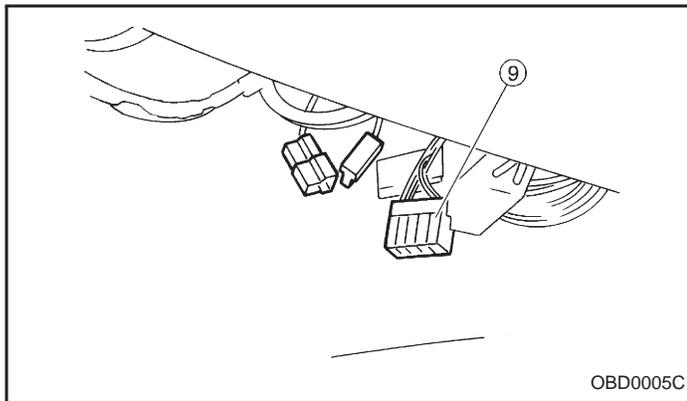

2. SOLENOID

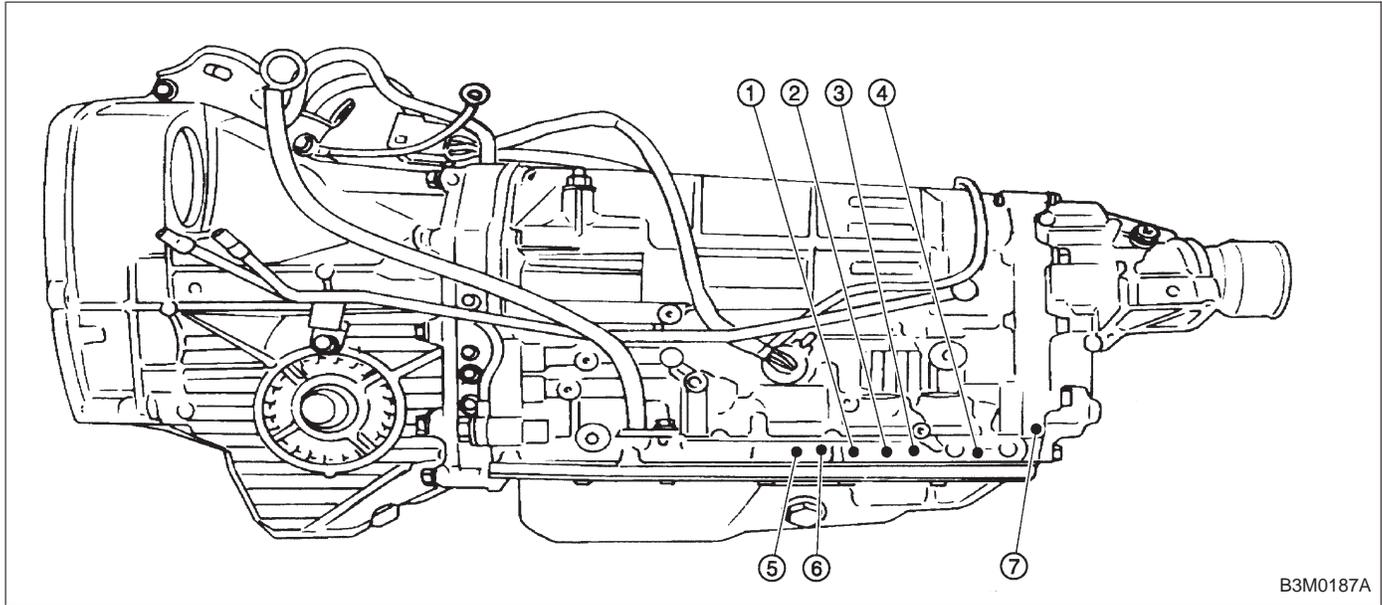

B3M0187A

- ① Duty solenoid A
- ② Solenoid 2
- ③ Solenoid 1
- ④ Solenoid 3

- ⑤ Duty solenoid B
- ⑥ ATF temperature sensor
- ⑦ Duty solenoid C (AWD)

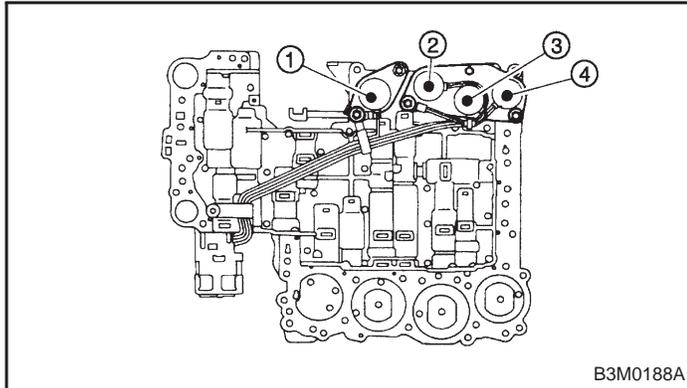

B3M0188A

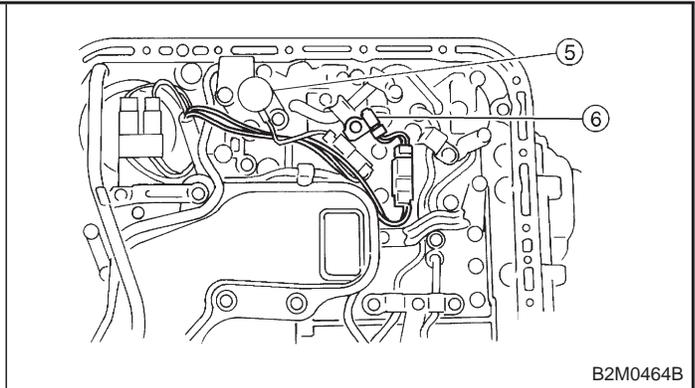

B2M0464B

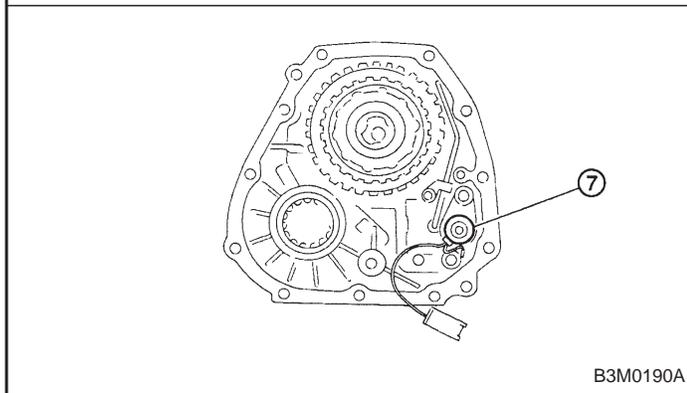

B3M0190A

SUBARU.