

11. Diagnostics Chart with Trouble Code

A: DIAGNOSTIC TROUBLE CODE (DTC) LIST

DTC No.	Abbreviation (Subaru select monitor)	Item	Page
P0100	QA	Mass air flow sensor circuit malfunction	76
P0101	QA — R	Mass air flow sensor circuit range/performance problem	77
P0105	P — S	Pressure sensor circuit malfunction	78
P0106	PS — R	Pressure sensor circuit range/performance problem	79
P0115	TW	Engine coolant temperature sensor circuit malfunction	80
P0120	THV	Throttle position sensor circuit malfunction	81
P0121	TH — R	Throttle position sensor circuit range/performance problem	82
P0125	TW — CL	Insufficient coolant temperature for closed loop fuel control	83
P0130	FO2 — V	Front oxygen sensor circuit malfunction	84
P0133	FO2 — R	Front oxygen sensor circuit slow response	85
P0135	FO2H	Front oxygen sensor heater circuit malfunction	86
P0136	RO2 — V	Rear oxygen sensor circuit malfunction	87
P0139	RO2 — R	Rear oxygen sensor circuit slow response	88
P0141	RO2H	Rear oxygen sensor heater circuit malfunction	89
P0170	FUEL	Fuel trim malfunction	90
P0201	INJ1	Fuel injector circuit malfunction - #1	91
P0202	INJ2	Fuel injector circuit malfunction - #2	
P0203	INJ3	Fuel injector circuit malfunction - #3	
P0204	INJ4	Fuel injector circuit malfunction - #4	
P0301	MIS — 1	Cylinder 1 misfire detected	92
P0302	MIS — 2	Cylinder 2 misfire detected	
P0303	MIS — 3	Cylinder 3 misfire detected	
P0304	MIS — 4	Cylinder 4 misfire detected	
P0325	KNOCK	Knock sensor circuit malfunction	93
P0335	CRANK	Crankshaft position sensor circuit malfunction	94
P0340	CAM	Camshaft position sensor circuit malfunction	95
P0400	EGR	Exhaust gas recirculation flow malfunction	96
P0403	EGRSOL	Exhaust gas recirculation circuit malfunction	97
P0420	CAT	Catalyst system efficiency below threshold	98
P0441	CPC — F	Evaporative emission control system incorrect purge flow	99
P0443	CPC	Evaporative emission control system purge control valve circuit malfunction	100
P0500	VSP	Vehicle speed sensor malfunction	101
P0505	ISC	Idle control system malfunction	102
P0506	ISC — L	Idle control system RPM lower than expected	103
P0507	ISC — H	Idle control system RPM higher than expected	104
P0600	—	Serial communication link malfunction	105
P0601	RAM	Internal control module memory check sum error	106
P0703	ATBRK	Brake switch input malfunction	107

DTC No.	Abbreviation (Subaru select monitor)	Item	Page
P0705	ATRNG	Transmission range sensor circuit malfunction	108
P0710	ATF	Transmission fluid temperature sensor circuit malfunction	109
P0720	ATVSP	Output speed sensor (vehicle speed sensor 1) circuit malfunction	110
P0725	ATNE	Engine speed input circuit malfunction	111
P0731	ATGR1	Gear 1 incorrect ratio	112
P0732	ATGR2	Gear 2 incorrect ratio	
P0733	ATGR3	Gear 3 incorrect ratio	
P0734	ATGR4	Gear 4 incorrect ratio	
P0740	ATLU — F	Torque converter clutch system malfunction	114
P0743	ATLU	Torque converter clutch system (duty solenoid B) electrical	115
P0748	ATPL	Pressure control solenoid (duty solenoid A) electrical	116
P0753	ATSFT1	Shift solenoid A (shift solenoid 1) electrical	117
P0758	ATSFT2	Shift solenoid B (shift solenoid 2) electrical	118
P0760	ATOVR — F	Shift solenoid C (shift solenoid 3) malfunction	119
P0763	ATOVR	Shift solenoid C (shift solenoid 3) electrical	120
P1100	ST — SW	Starter switch circuit malfunction	121
P1101	N/P — SW	Neutral position switch circuit malfunction	122
P1102	BR	Pressure sources switching solenoid valve circuit malfunction	123
P1103	TRQ	Engine torque control signal circuit malfunction	124
P1500	FAN — 1	Radiator fan relay 1 circuit malfunction	125
P1502	FAN — F	Radiator fan function problem	126
P1700	ATTH	Throttle position sensor circuit malfunction	127
P1701	ATCRS	Cruise control set signal circuit malfunction	128
P1702	ATDIAG	Automatic transmission diagnosis input signal circuit malfunction	129

B: DTC P0100

— MASS AIR FLOW SENSOR CIRCUIT MALFUNCTION (QA) —

WIRING DIAGRAM:

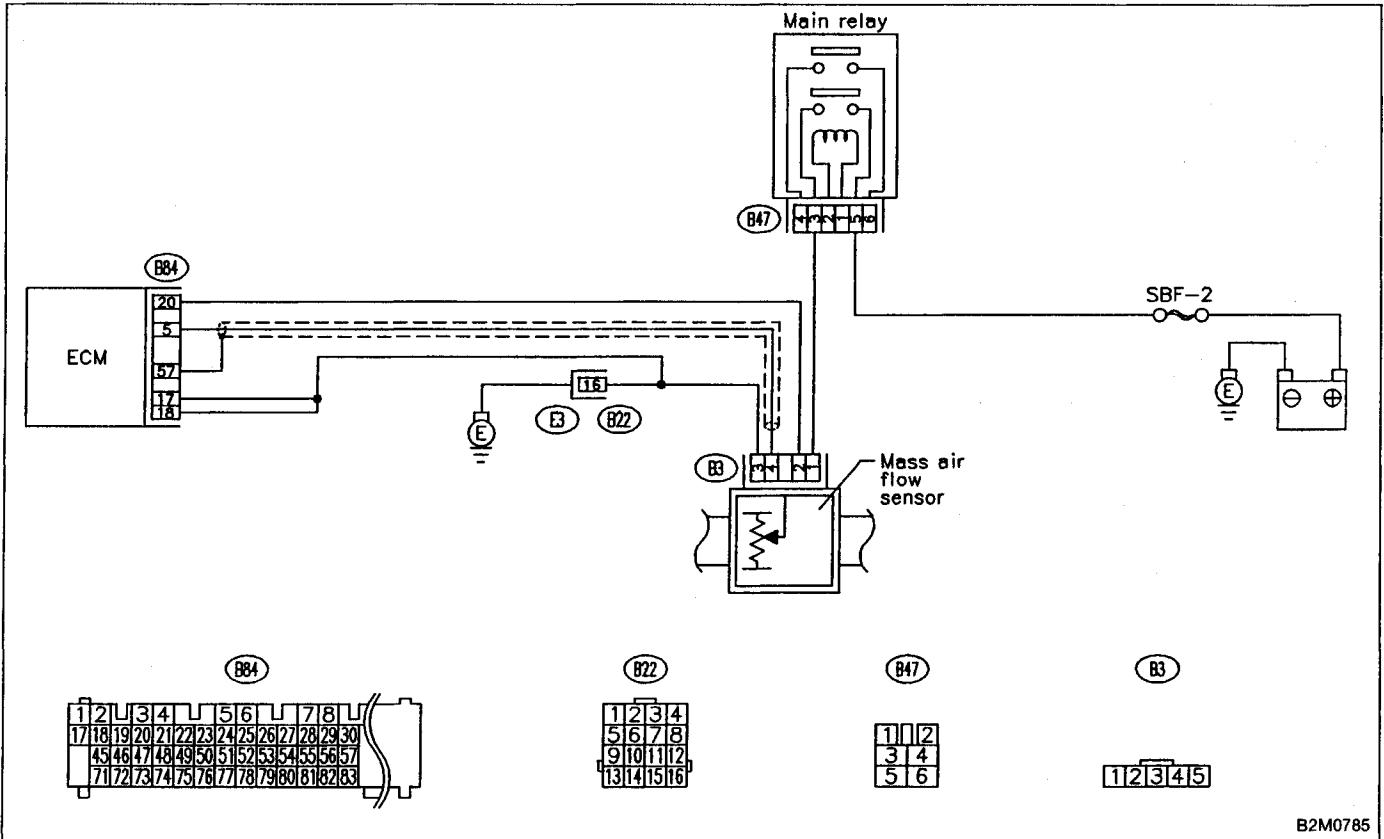

B2M0785

NOTE:

For the diagnostic procedure on mass air flow sensor circuit malfunction (DTC P0100), refer to 2-7 [T10B0]☆2.

C: DTC P0101
— MASS AIR FLOW SENSOR CIRCUIT
RANGE/PERFORMANCE PROBLEM
(QA — R) —

WIRING DIAGRAM:

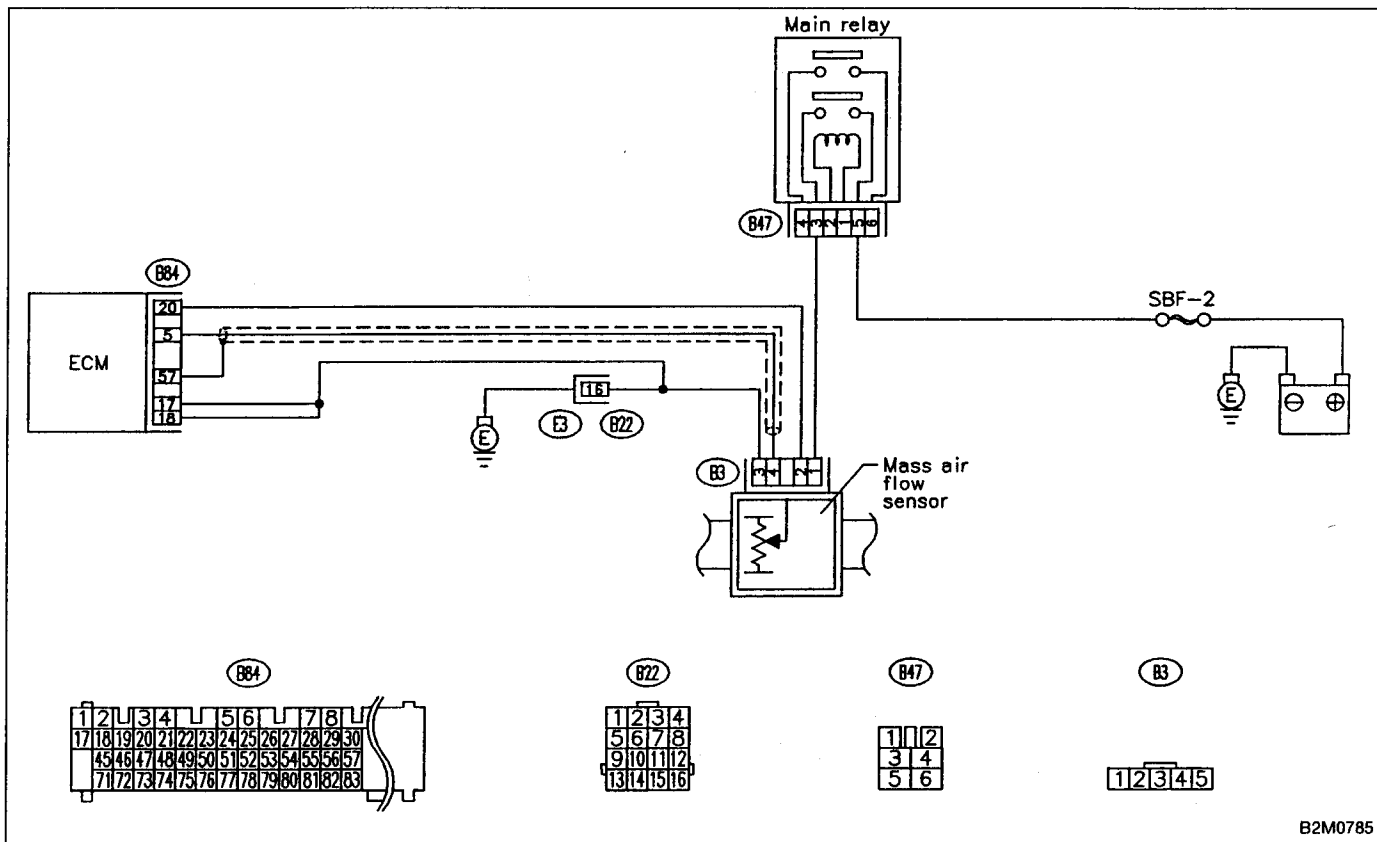

B2M0785

NOTE:

For the diagnostic procedure on mass air flow sensor circuit range/performance problem (DTC P0101), refer to 2-7 [T10C0]☆2.

E: DTC P0106
— PRESSURE SENSOR CIRCUIT
RANGE/PERFORMANCE PROBLEM (PS — R) —

WIRING DIAGRAM:

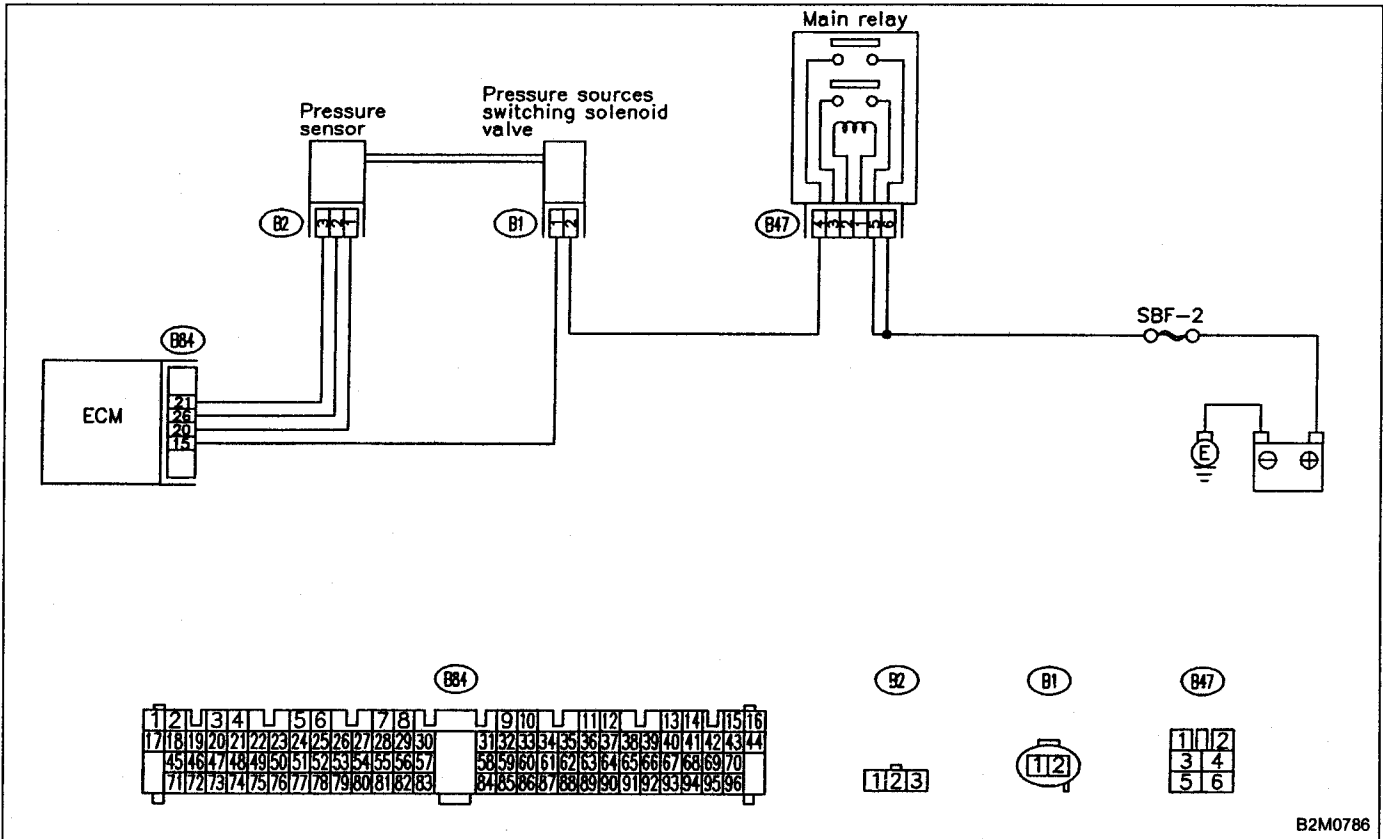

B2M0786

NOTE:
 For the diagnostic procedure on pressure sensor circuit range/performance problem (DTC P0106), refer to 2-7 [T10E0]☆2.

F: DTC P0115
— ENGINE COOLANT TEMPERATURE
SENSOR CIRCUIT MALFUNCTION (TW) —

WIRING DIAGRAM:

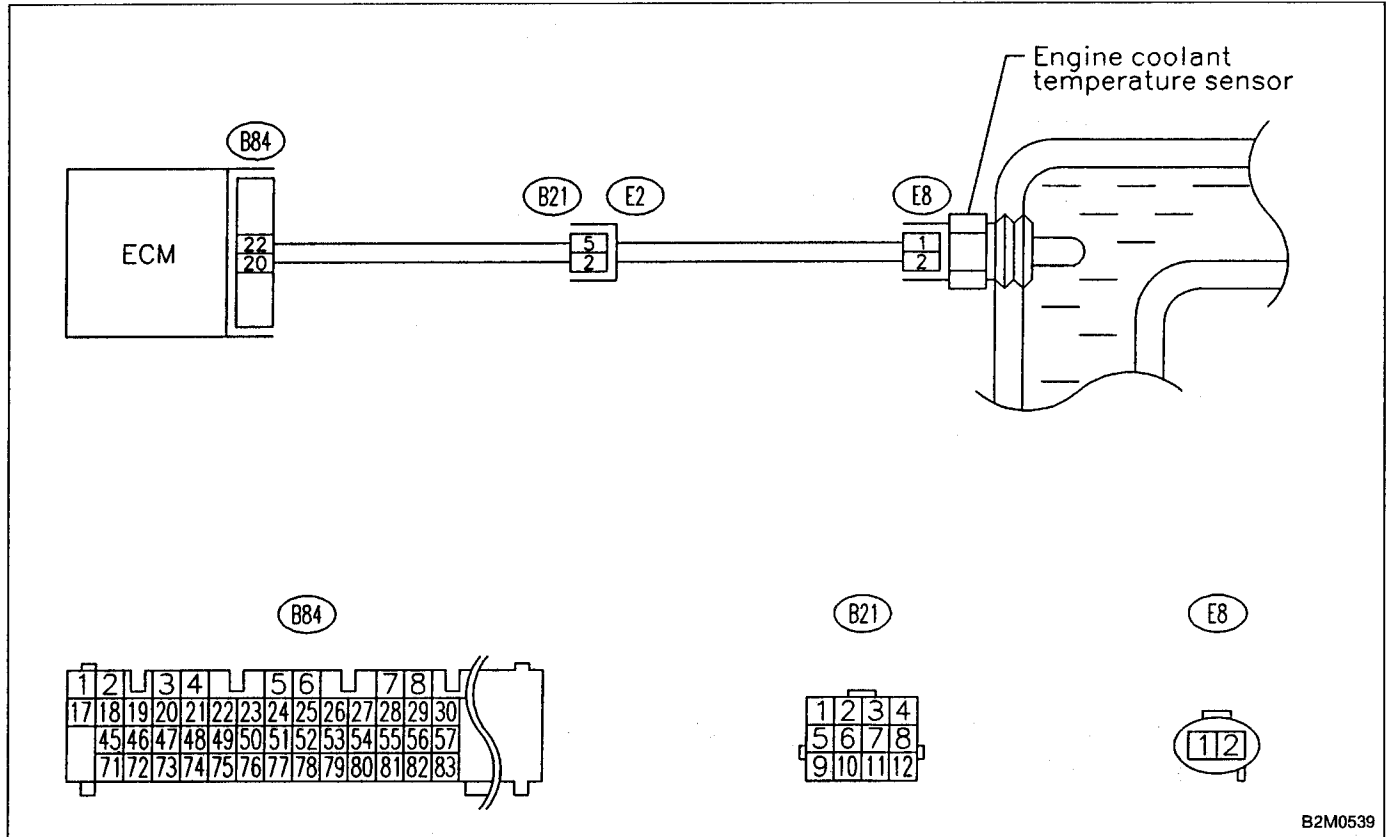

B2M0539

NOTE:
 For the diagnostic procedure on engine coolant temperature sensor circuit malfunction (DTC P0115), refer to 2-7 [T10F0]☆2.

G: DTC P0120
— THROTTLE POSITION SENSOR CIRCUIT
MALFUNCTION (THV) —

WIRING DIAGRAM:

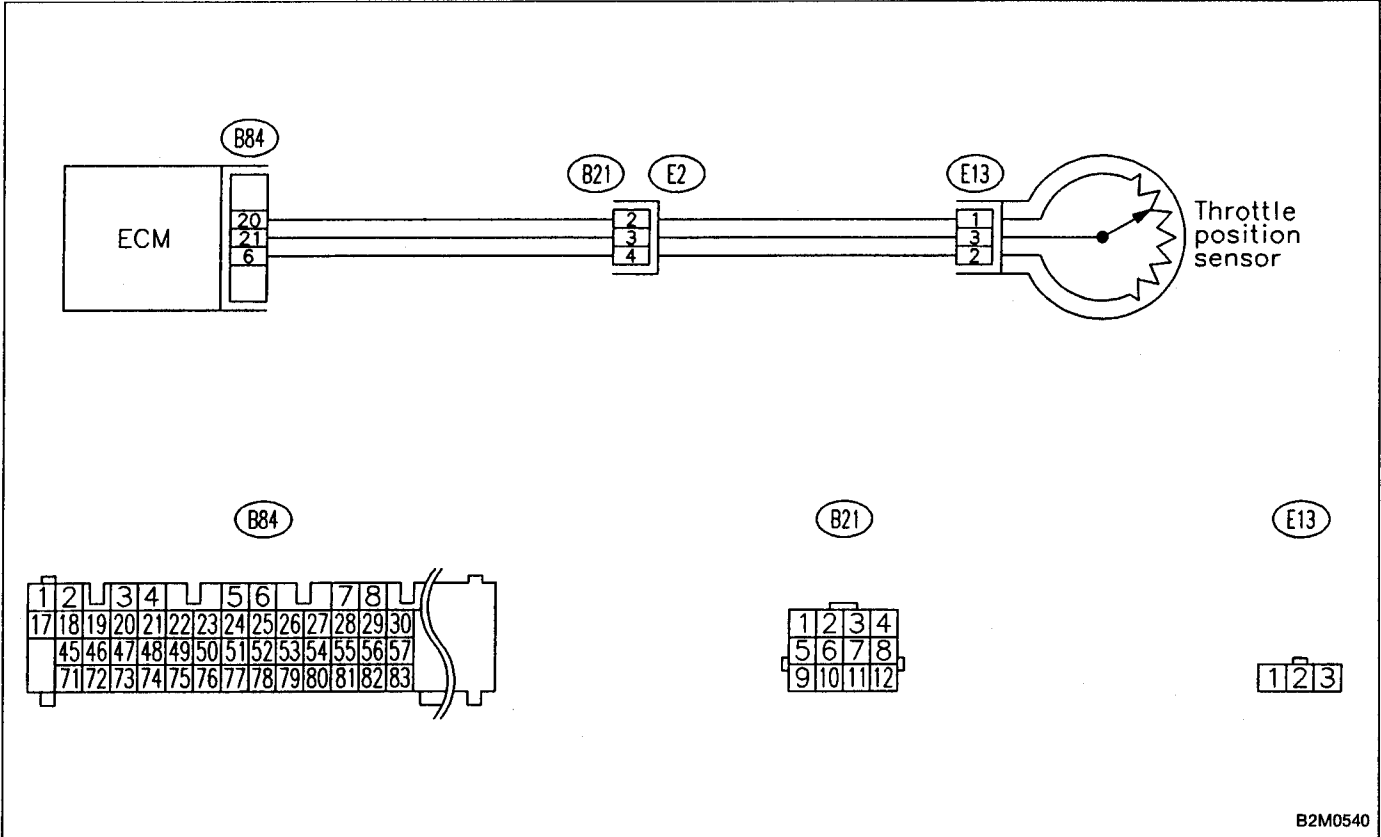

NOTE:

For the diagnostic procedure on throttle position sensor circuit malfunction (DTC P0120), refer to 2-7 [T10G0]☆2.

H: DTC P0121
— THROTTLE POSITION SENSOR CIRCUIT
RANGE/PERFORMANCE PROBLEM
(TH – R) —

WIRING DIAGRAM:

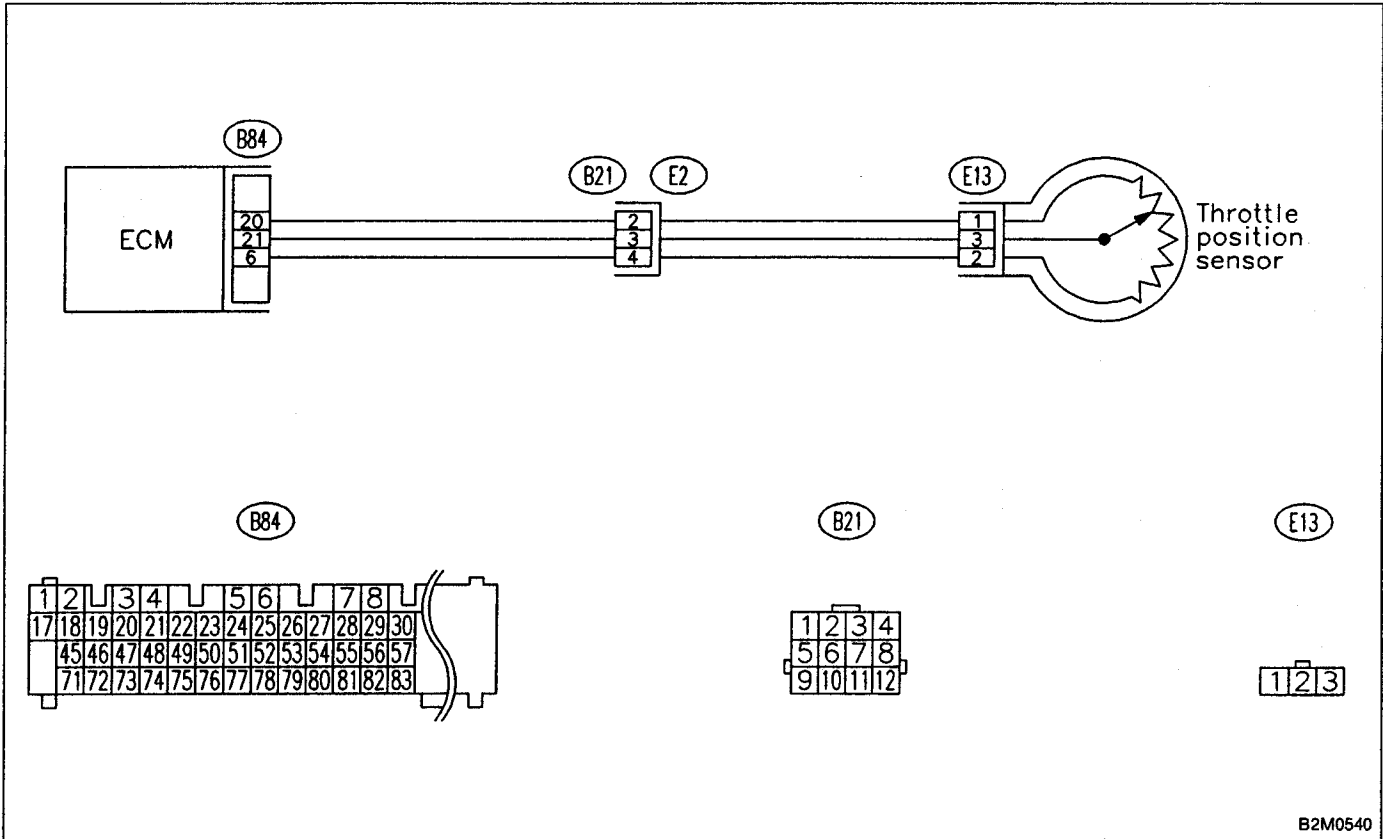

NOTE:
 For the diagnostic procedure on throttle position sensor circuit range/performance problem (DTC P0121), refer to 2-7 [T10H0]☆2.

I: DTC P0125
— INSUFFICIENT COOLANT TEMPERATURE
FOR CLOSED LOOP FUEL CONTROL
(TW — CL) —

WIRING DIAGRAM:

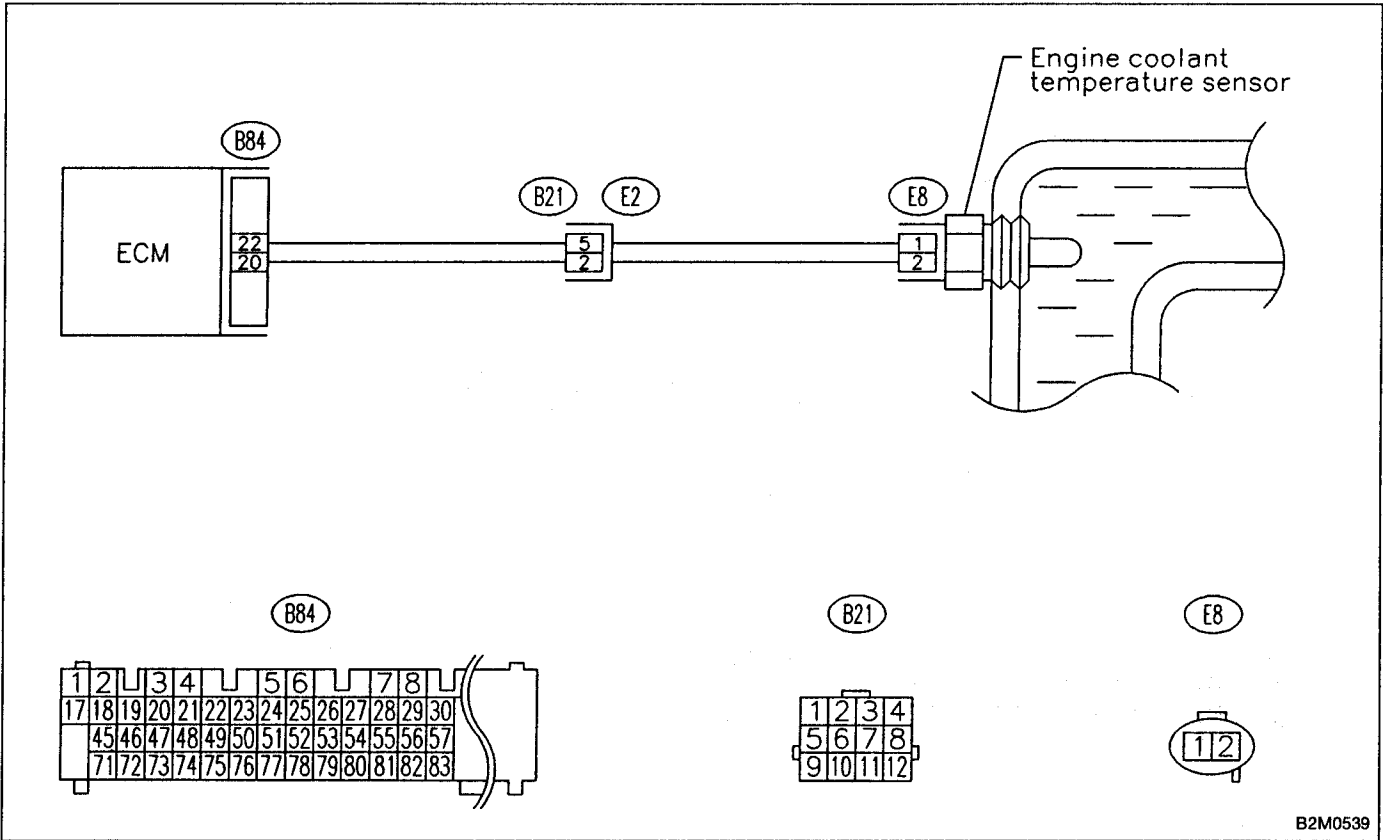

B2M0539

NOTE:

For the diagnostic procedure on insufficient coolant temperature for closed loop fuel control (DTC P0125), refer to 2-7 [T1010]☆2.

**J: DTC P0130
 — FRONT OXYGEN SENSOR CIRCUIT
 MALFUNCTION (FO2 — V) —**

WIRING DIAGRAM:

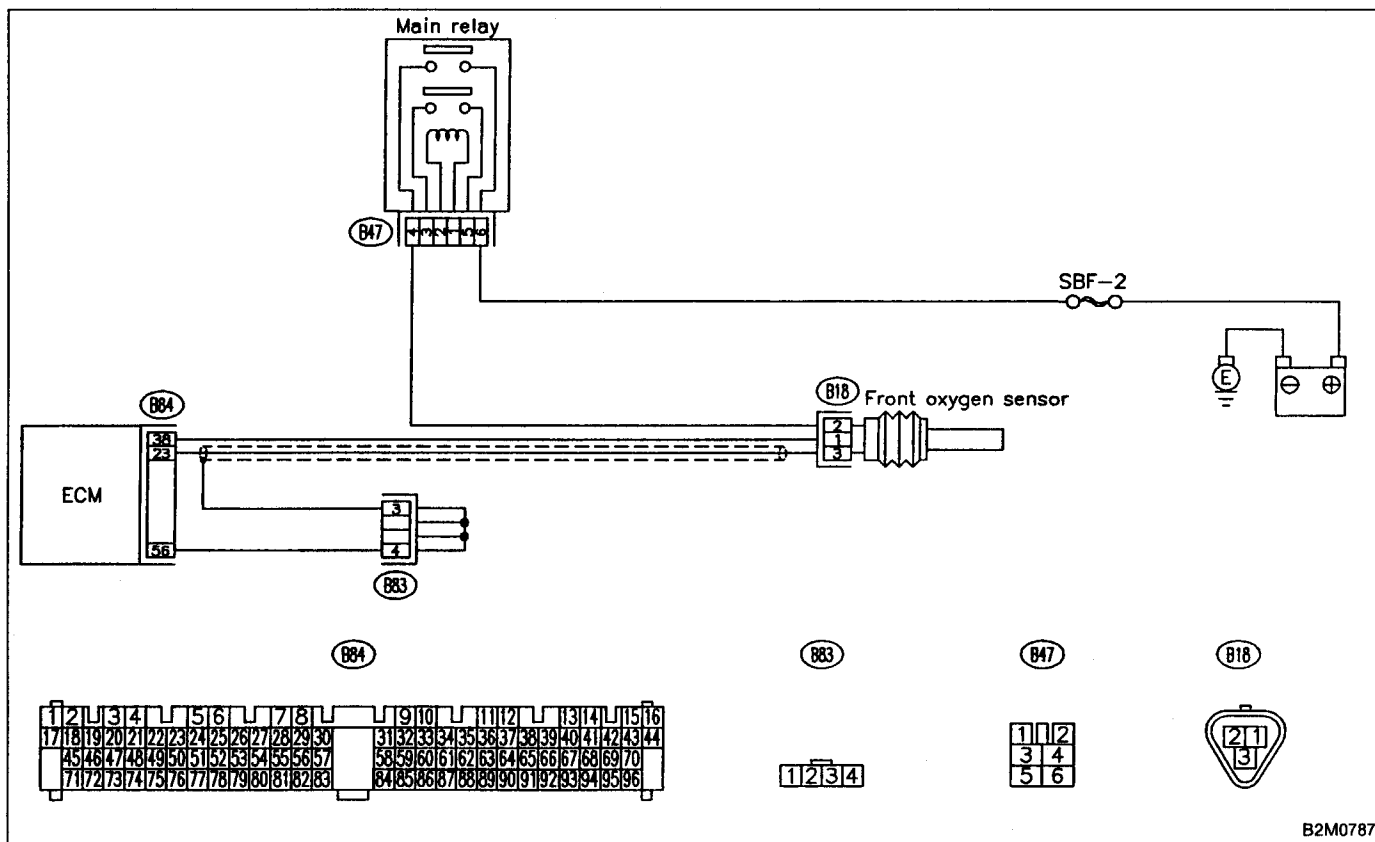

B2M0787

NOTE:
 For the diagnostic procedure on front oxygen sensor circuit malfunction (DTC P0130), refer to 2-7 [T10J0]☆2.

K: DTC P0133
— FRONT OXYGEN SENSOR CIRCUIT SLOW
RESPONSE (FO2 — R) —

WIRING DIAGRAM:

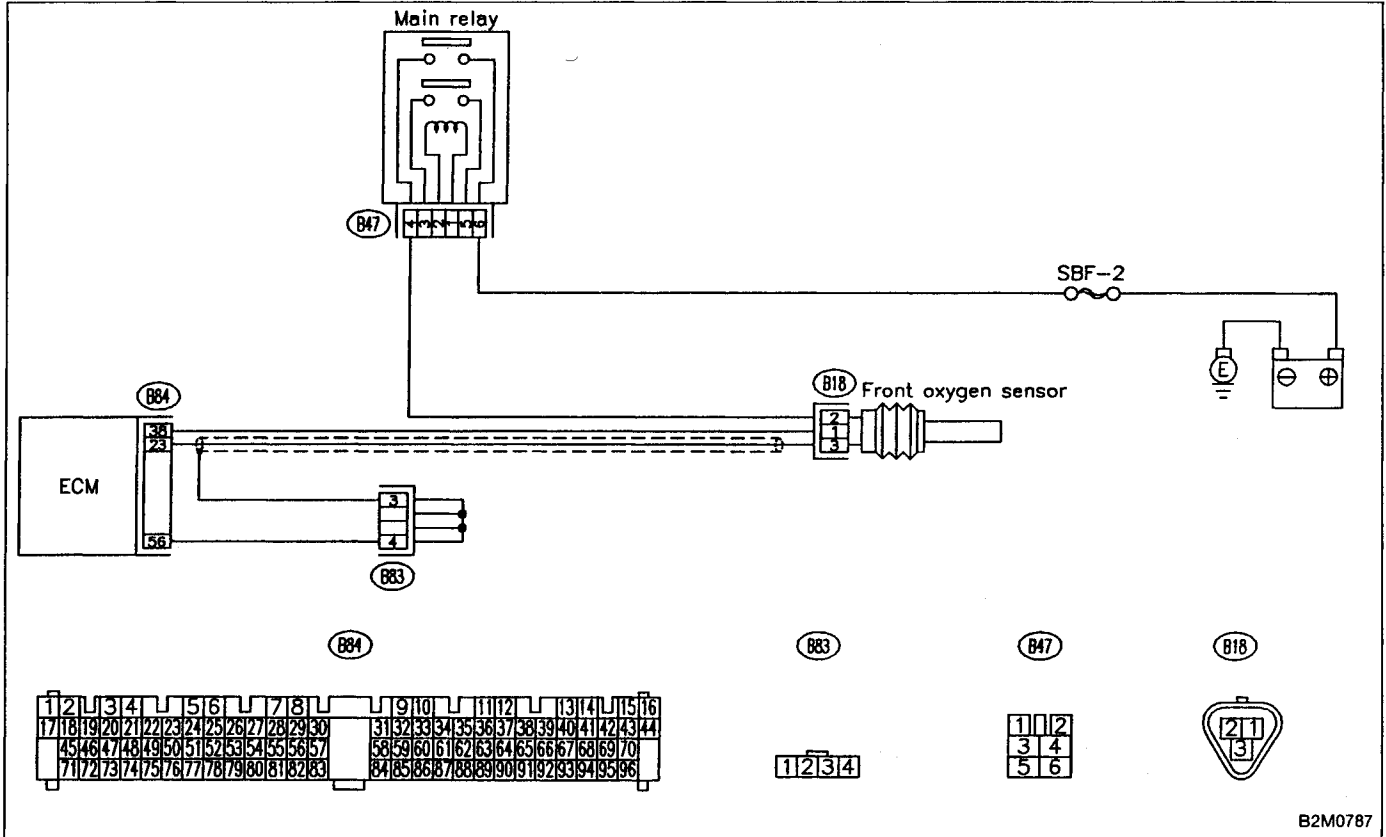

NOTE:
 For the diagnostic procedure on front oxygen sensor circuit slow response (DTC P0133), refer to 2-7 [T10K0]☆2.

L: DTC P0135
— FRONT OXYGEN SENSOR HEATER CIRCUIT
MALFUNCTION (FO2H) —

WIRING DIAGRAM:

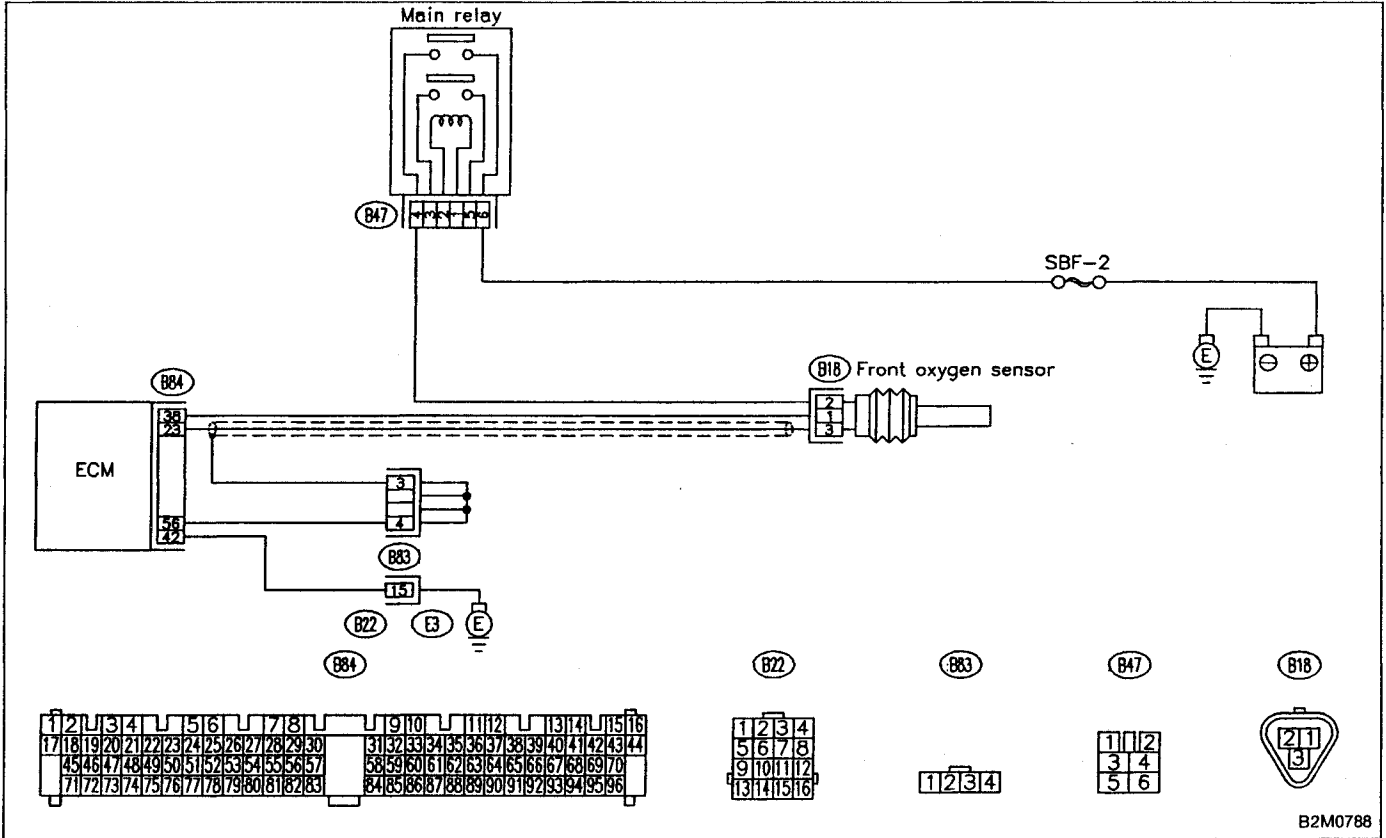

B2M0788

NOTE:
 For the diagnostic procedure on front oxygen sensor heater circuit malfunction (DTC P0135), refer to 2-7 [T10L0]☆2.

M: DTC P0136
— REAR OXYGEN SENSOR CIRCUIT
MALFUNCTION (RO2 — V) —

WIRING DIAGRAM:

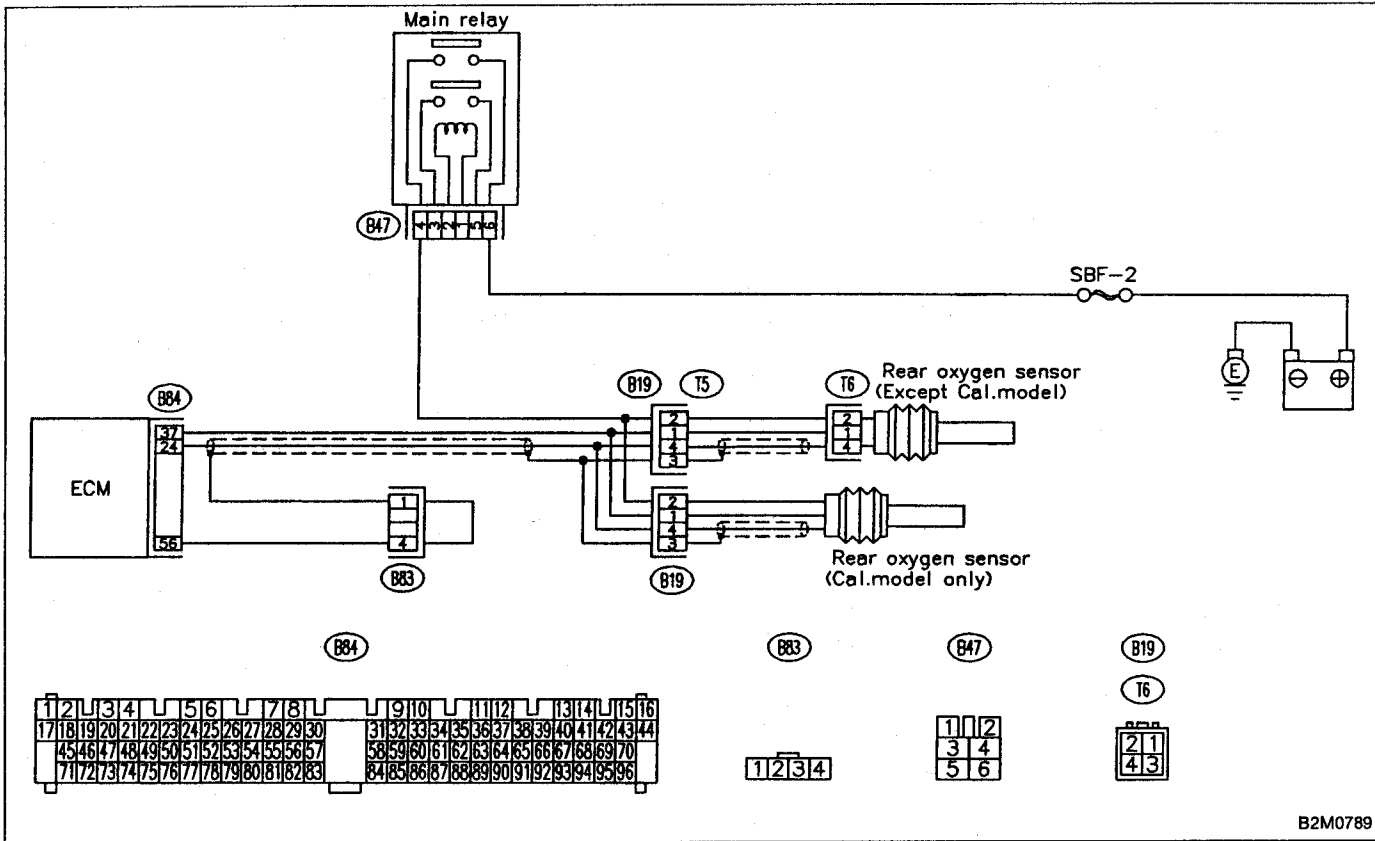

B2M0789

NOTE:
 For the diagnostic procedure on rear oxygen sensor circuit malfunction (DTC P0136), refer to 2-7 [T10M0]☆2.

N: DTC P0139
— REAR OXYGEN SENSOR CIRCUIT SLOW
RESPONSE (RO2 — R) —

WIRING DIAGRAM:

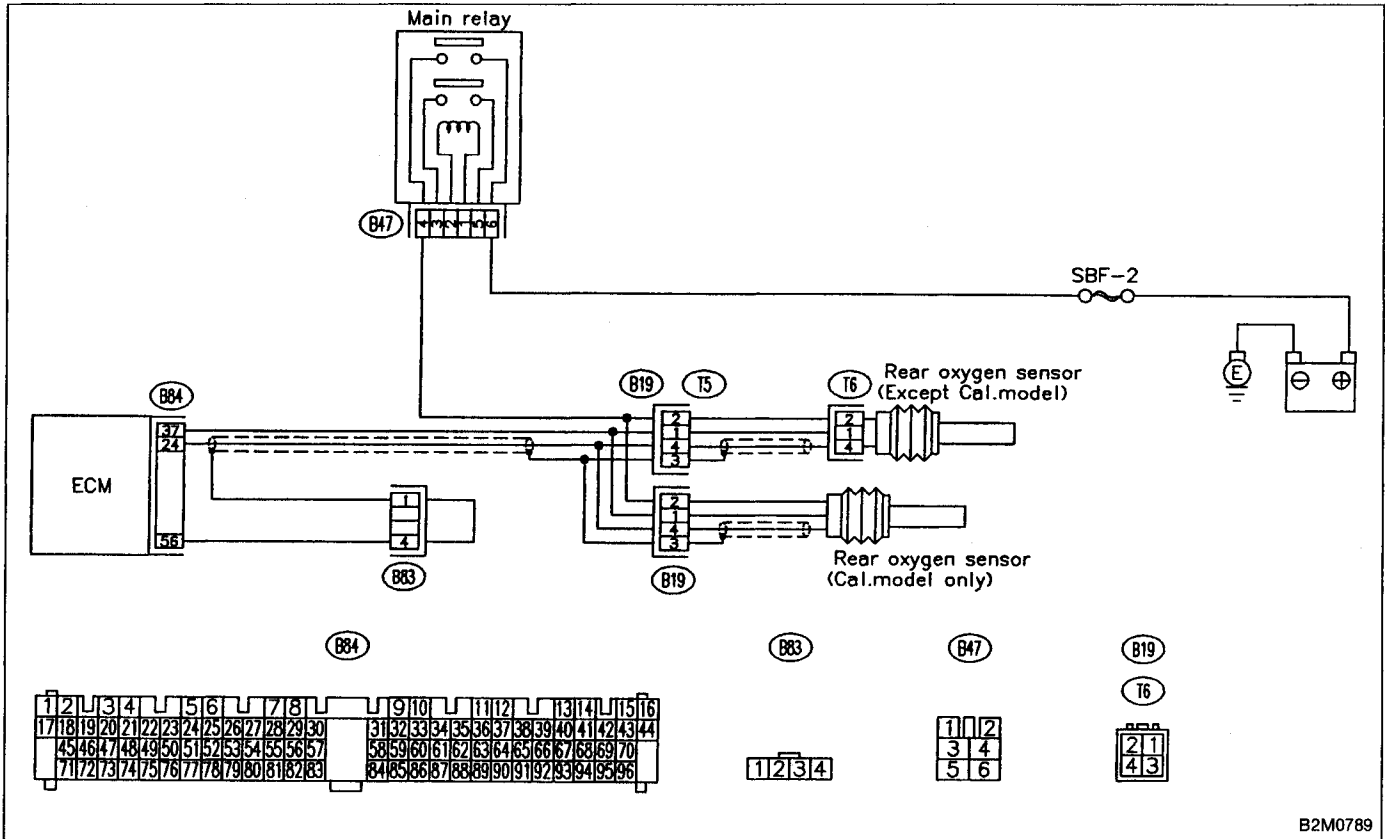

B2M0789

NOTE:
For the diagnostic procedure on rear oxygen sensor circuit slow response (DTC P0139), refer to 2-7 [T10N0]☆2.

O: DTC P0141
— REAR OXYGEN SENSOR HEATER CIRCUIT
MALFUNCTION (RO2H) —

WIRING DIAGRAM:

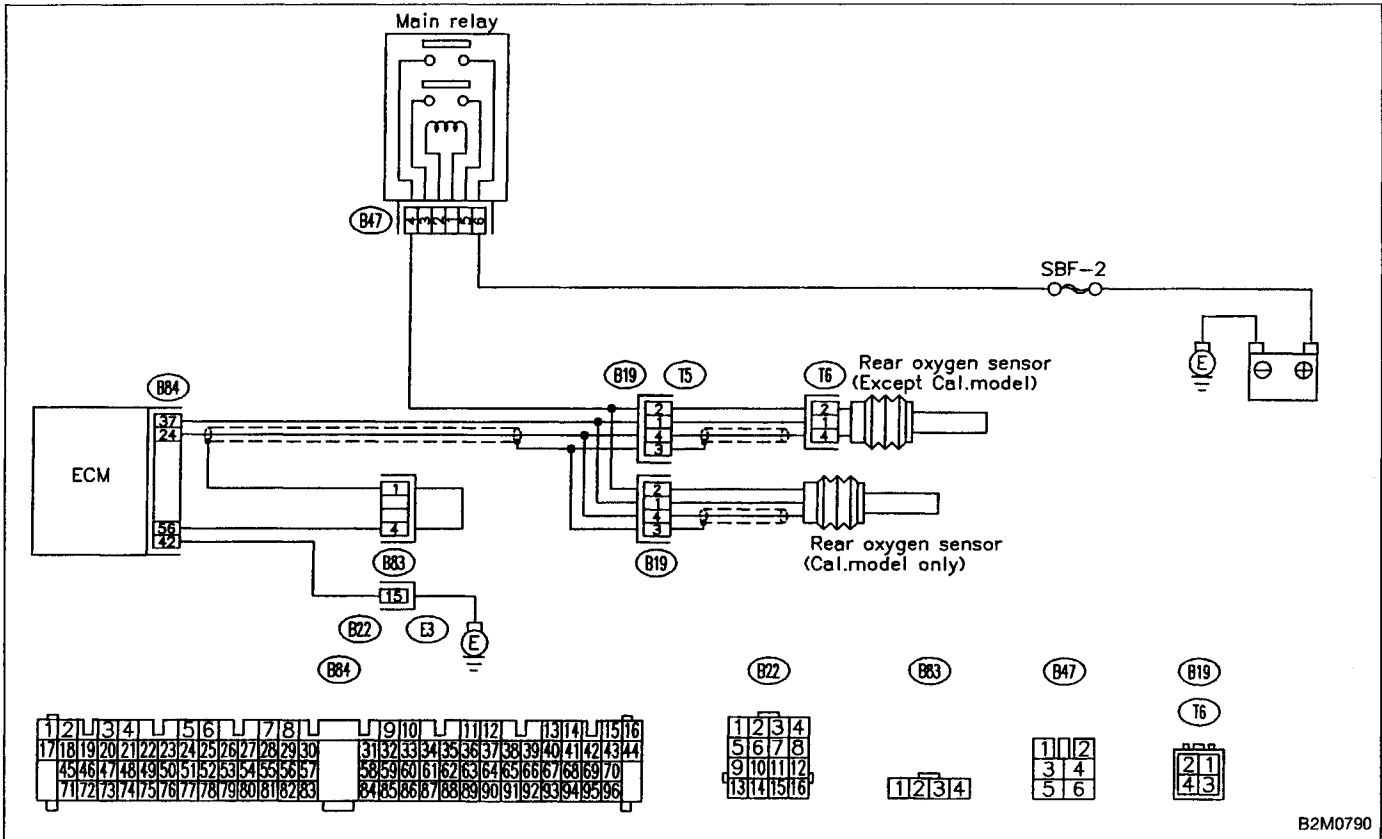

NOTE:
 For the diagnostic procedure on rear oxygen sensor heater circuit malfunction (DTC P0141), refer to 2-7 [T1000]☆2.

P: DTC P0170

— FUEL TRIM MALFUNCTION (FUEL) —

NOTE:

For the diagnostic procedure on fuel trim malfunction (DTC P0170), refer to 2-7 [T10P0]☆2.

Q: DTC P0201
 — FUEL INJECTOR CIRCUIT MALFUNCTION -
 #1 (INJ1) —

R: DTC P0202
 — FUEL INJECTOR CIRCUIT MALFUNCTION -
 #2 (INJ2) —

S: DTC P0203
 — FUEL INJECTOR CIRCUIT MALFUNCTION -
 #3 (INJ3) —

T: DTC P0204
 — FUEL INJECTOR CIRCUIT MALFUNCTION -
 #4 (INJ4) —

WIRING DIAGRAM:

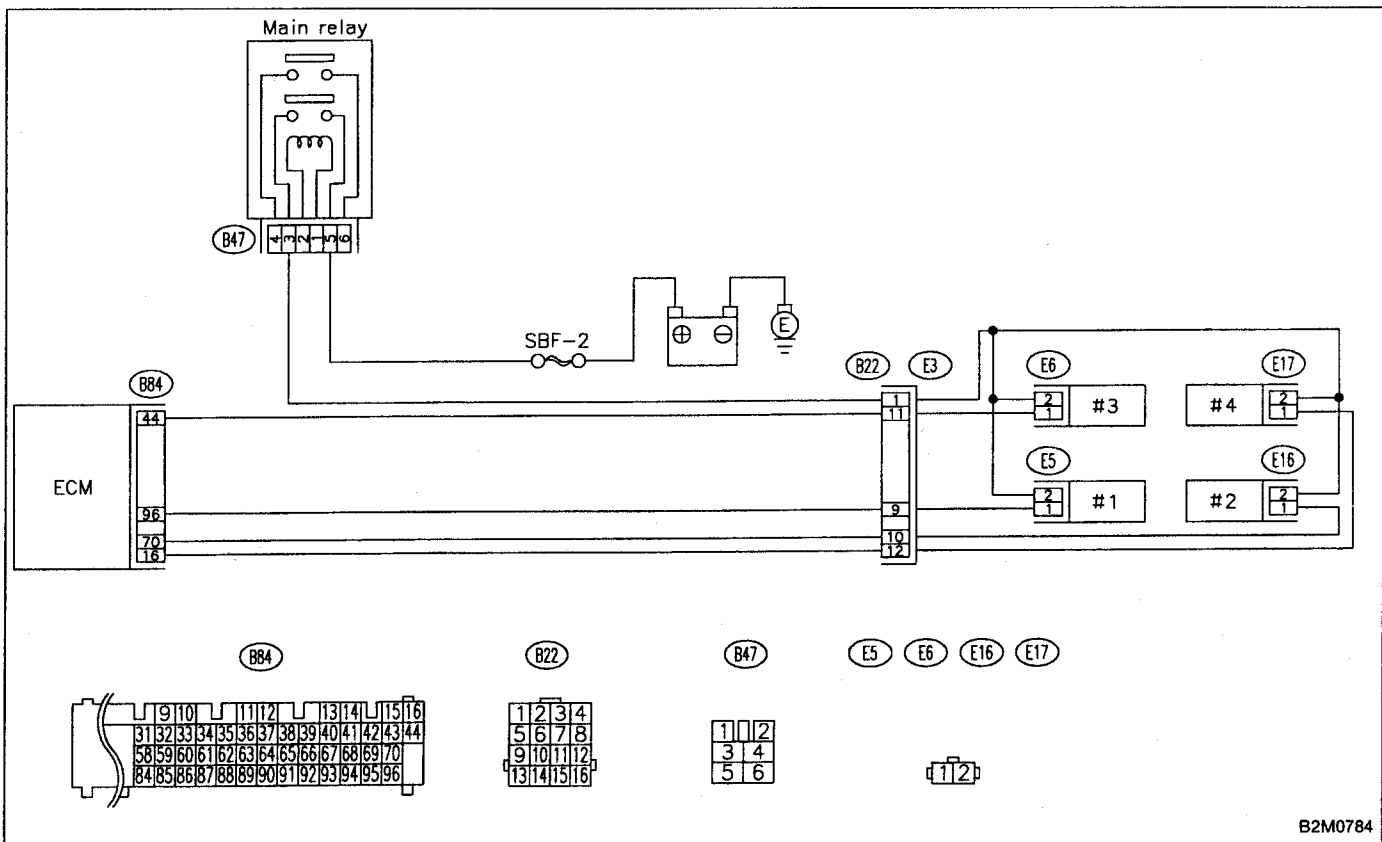

B2M0784

NOTE:

For the diagnostic procedure on fuel injector circuit malfunction — #1 (DTC P0201), #2 (DTC P0202), #3 (DTC P0203) and #4 (DTC P0204), refer to 2-7 [T10Q0, T10R0, T10S0 and T10T0]☆2.

Y: DTC P0325
— KNOCK SENSOR CIRCUIT MALFUNCTION
(KNOCK) —

WIRING DIAGRAM:

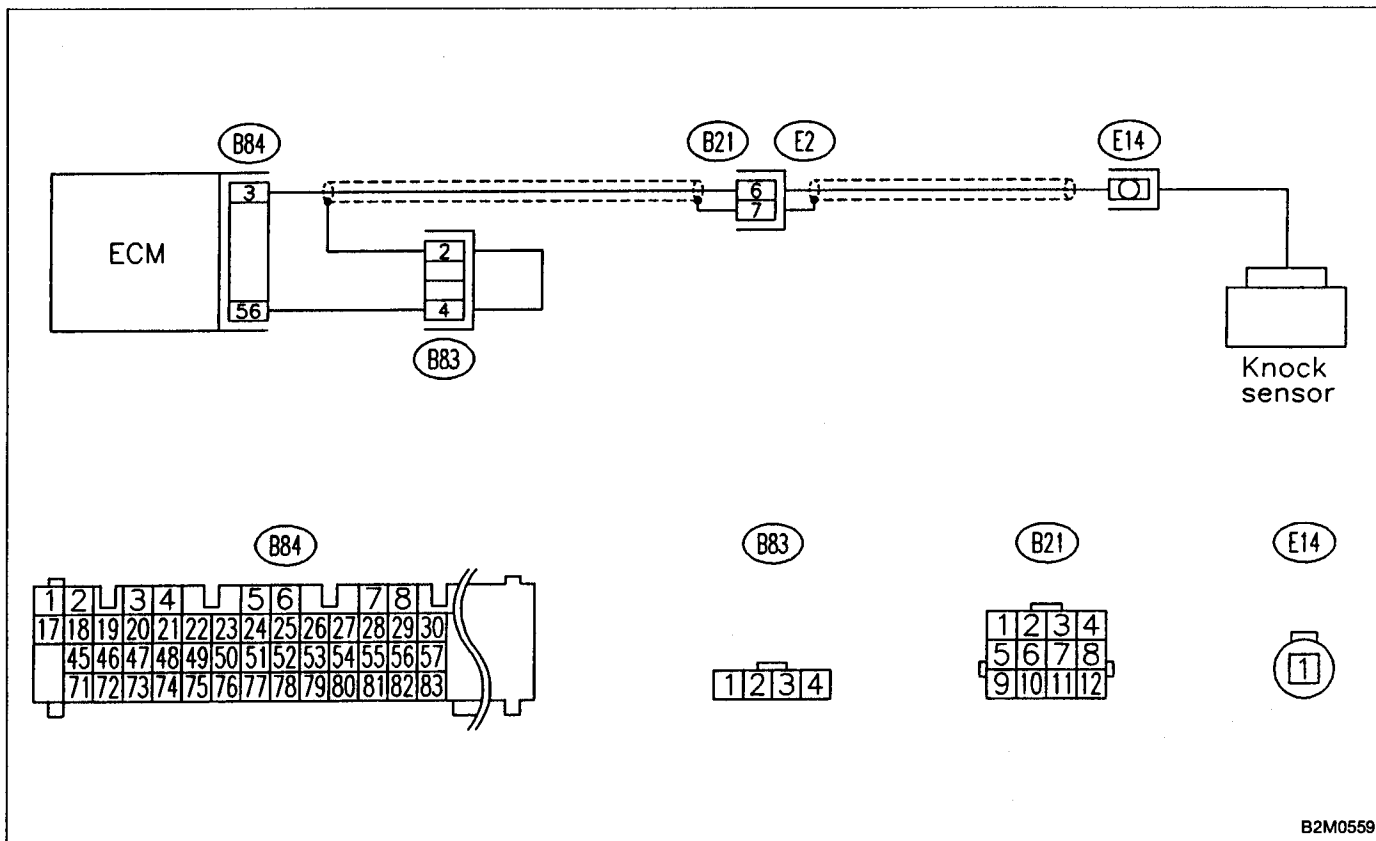

B2M0559

NOTE:
 For the diagnostic procedure on knock sensor circuit malfunction (DTC P0325), refer to 2-7 [T10Y0]☆2.

Z: DTC P0335
— CRANKSHAFT POSITION SENSOR CIRCUIT MALFUNCTION (CRANK) —

WIRING DIAGRAM:

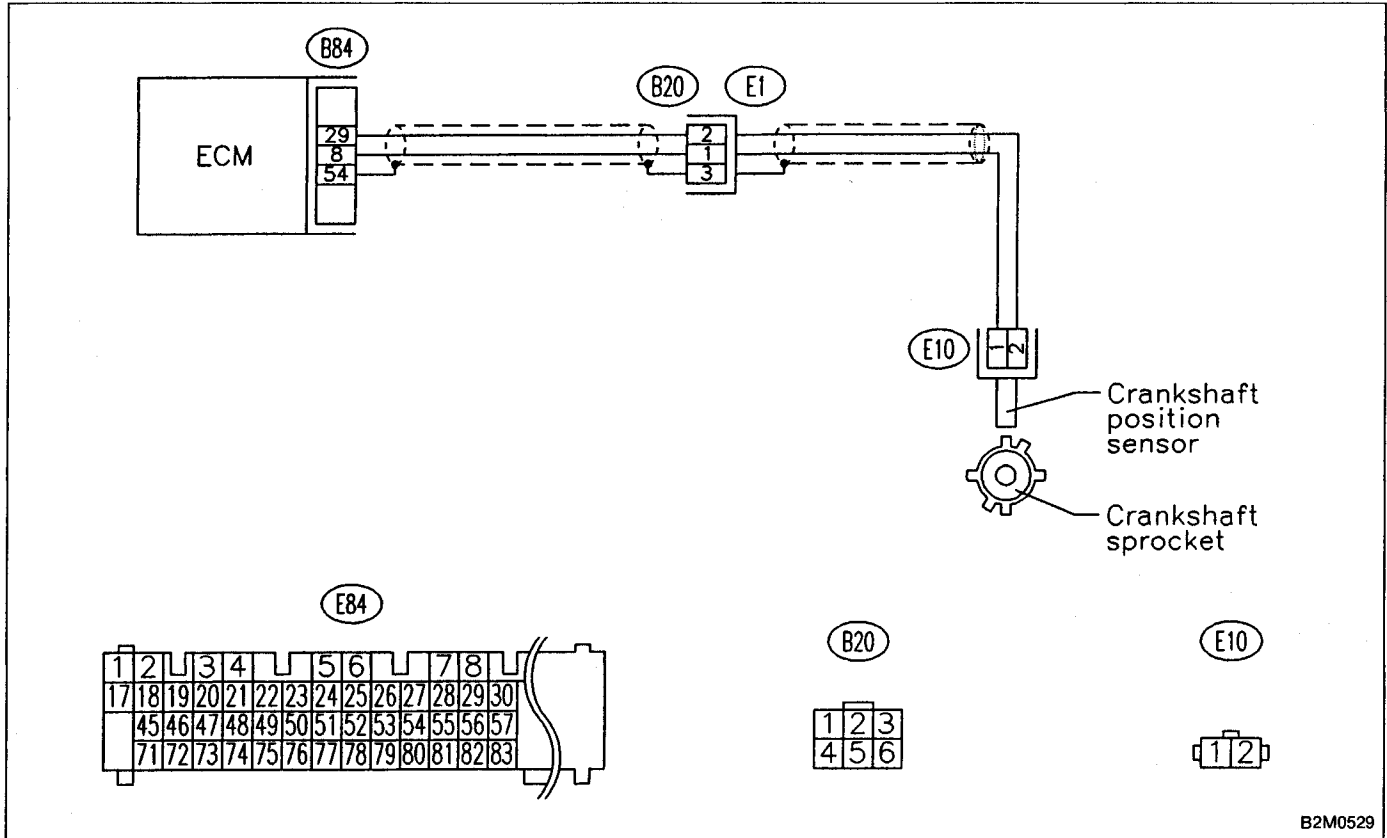

NOTE:
For the diagnostic procedure on crankshaft position sensor circuit malfunction (DTC P0335), refer to 2-7 [T10Z0]☆2.

AA: DTC P0340
— CAMSHAFT POSITION SENSOR CIRCUIT
MALFUNCTION (CAM) —

WIRING DIAGRAM:

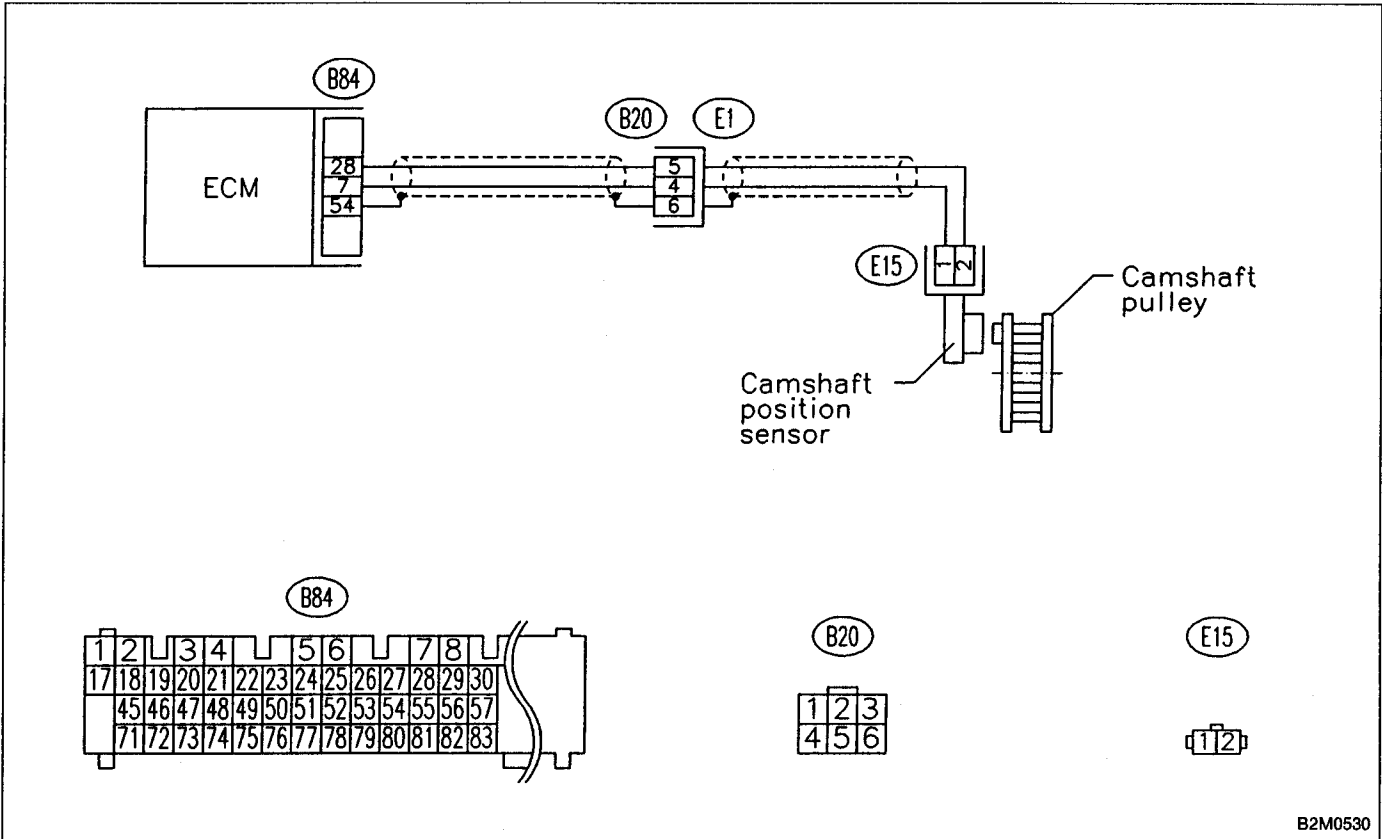

NOTE:

For the diagnostic procedure on camshaft position sensor malfunction (DTC P0340), refer to 2-7 [T10AA0]☆2.

AB: DTC P0400
— EXHAUST GAS RECIRCULATION FLOW
MALFUNCTION (EGR) —

WIRING DIAGRAM:

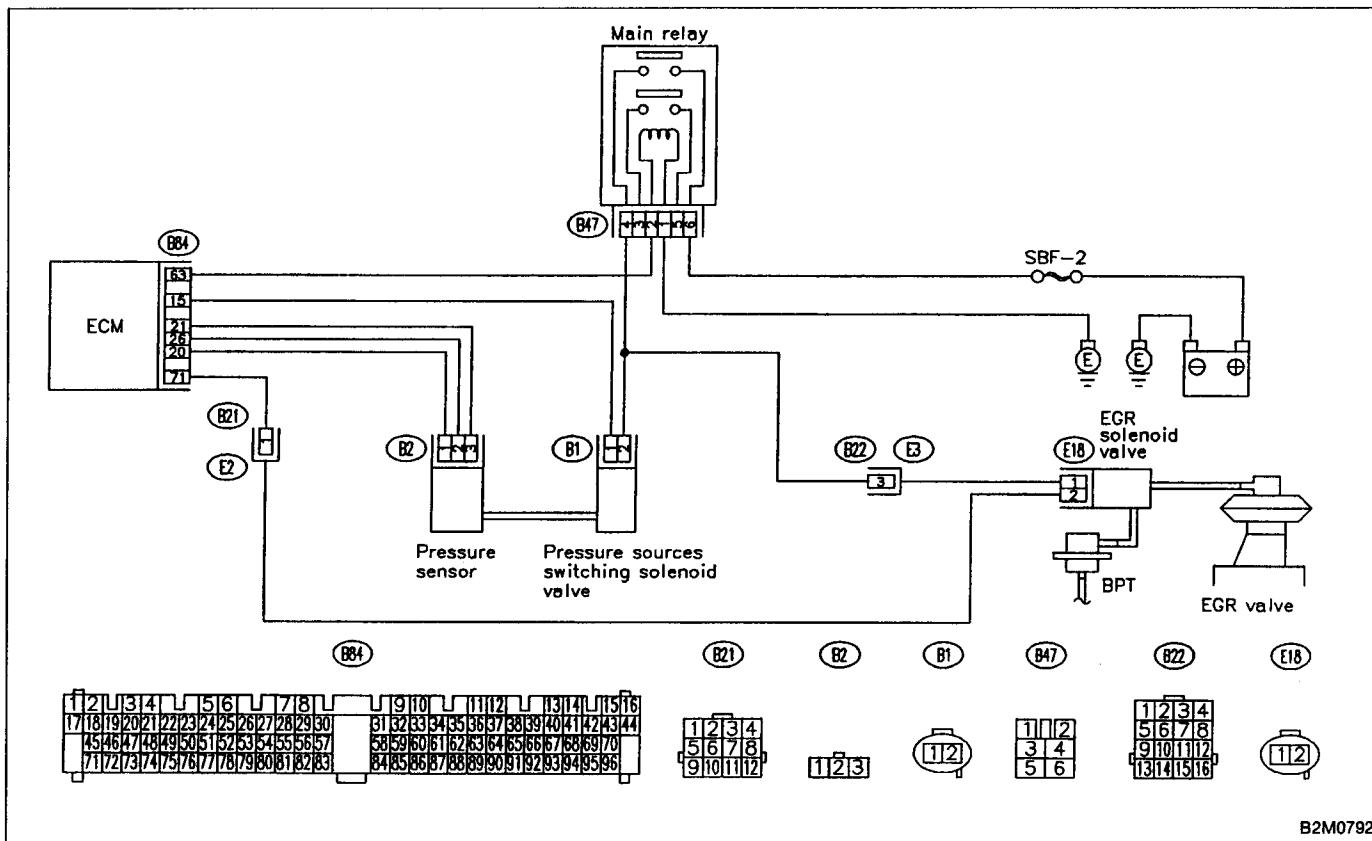

B2M0792

NOTE:
 For the diagnostic procedure on exhaust gas recirculation flow malfunction (DTC P0400), refer to 2-7 [T10AB0]☆2.

AC: DTC P0403
— EXHAUST GAS RECIRCULATION CIRCUIT
MALFUNCTION (EGRSOL) —

WIRING DIAGRAM:

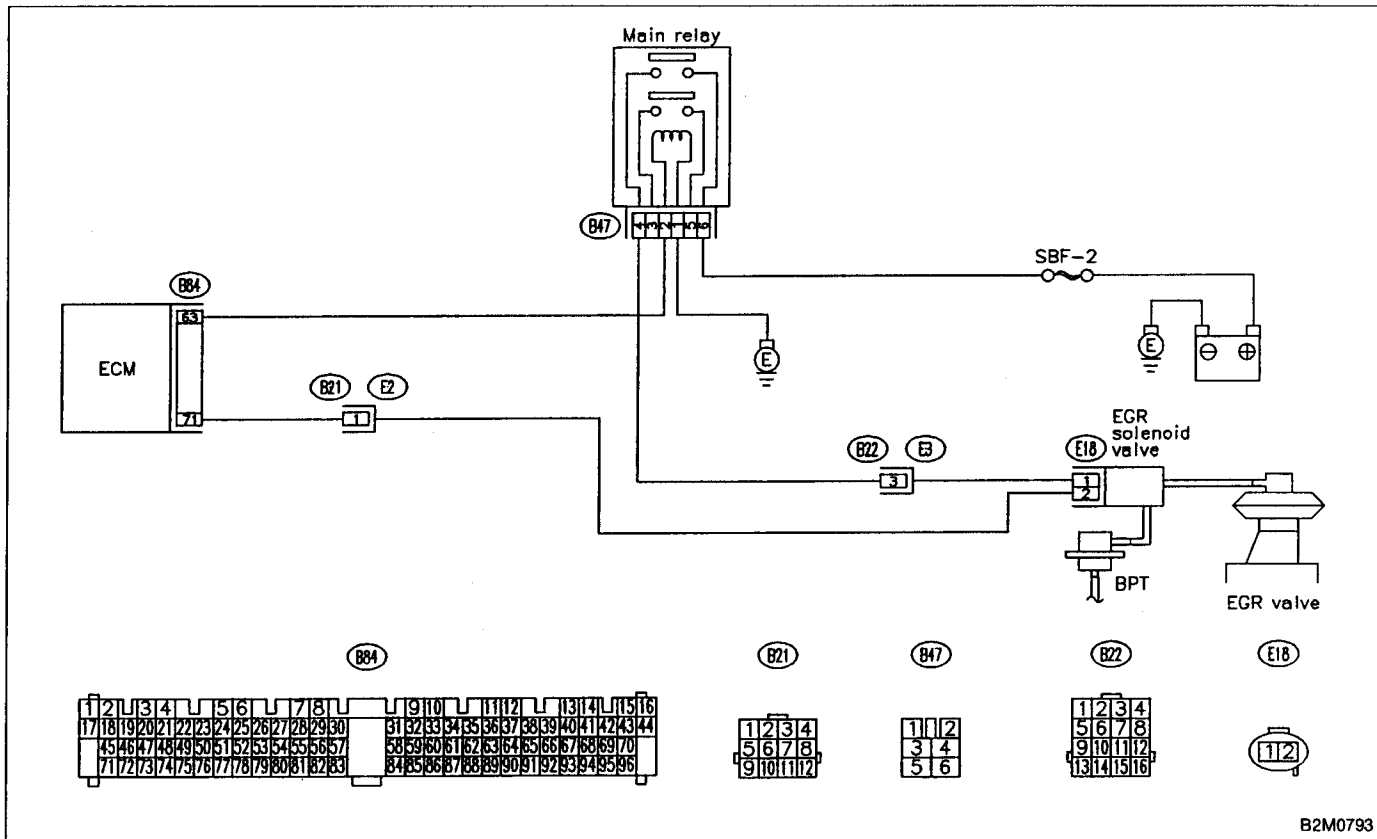

B2M0793

NOTE:

For the diagnostic procedure on exhaust gas recirculation circuit malfunction (DTC P0403), refer to 2-7 [T10AC0]☆2.

AD: DTC P0420
— CATALYST SYSTEM EFFICIENCY BELOW THRESHOLD (CAT) —

WIRING DIAGRAM:

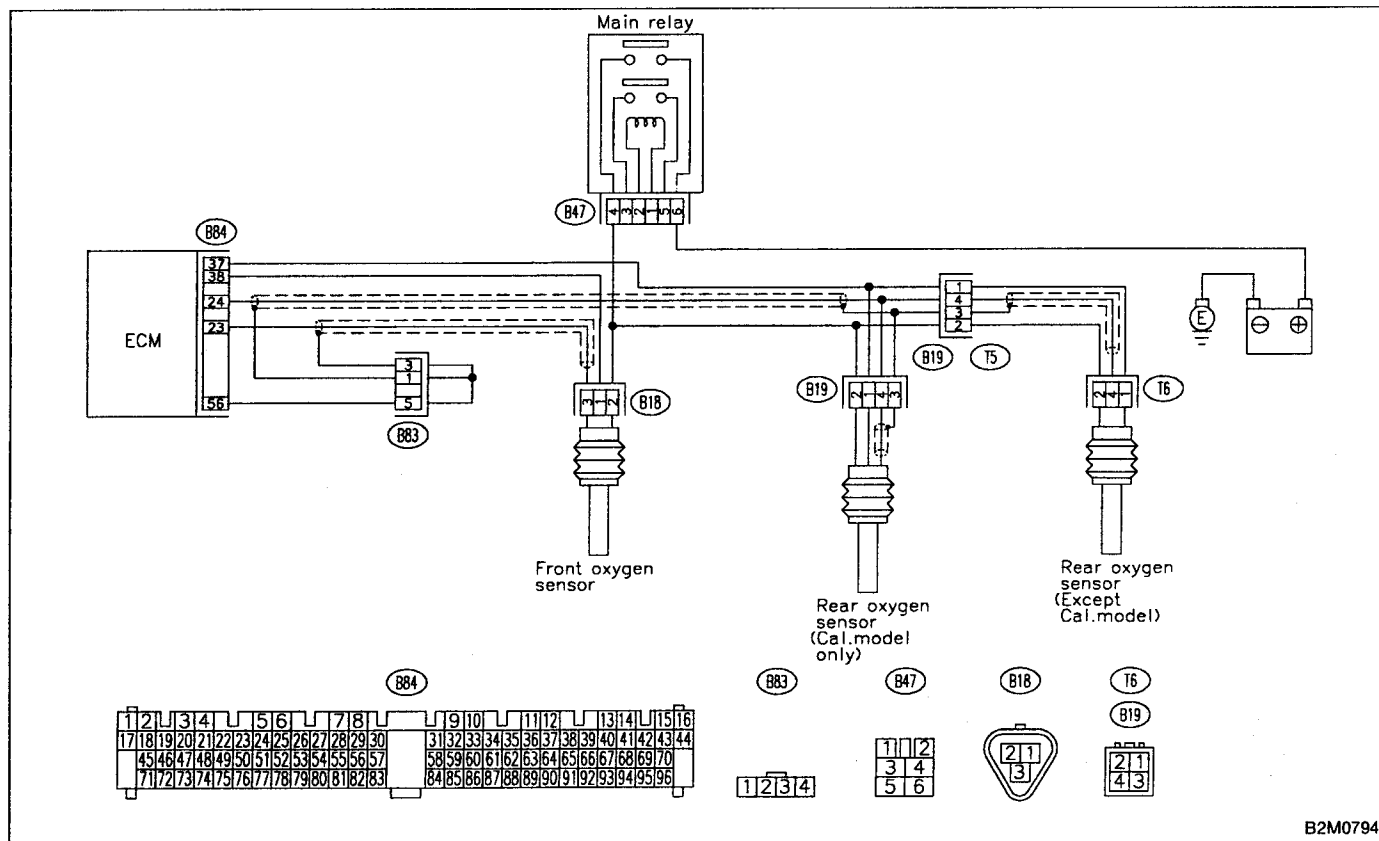

B2M0794

NOTE:

For the diagnostic procedure on catalyst system efficiency below threshold (DTC P0420), refer to 2-7 [T10AD0]☆2.

AE: DTC P0441
— EVAPORATIVE EMISSION CONTROL
SYSTEM INCORRECT PURGE FLOW
(CPC — F) —

WIRING DIAGRAM:

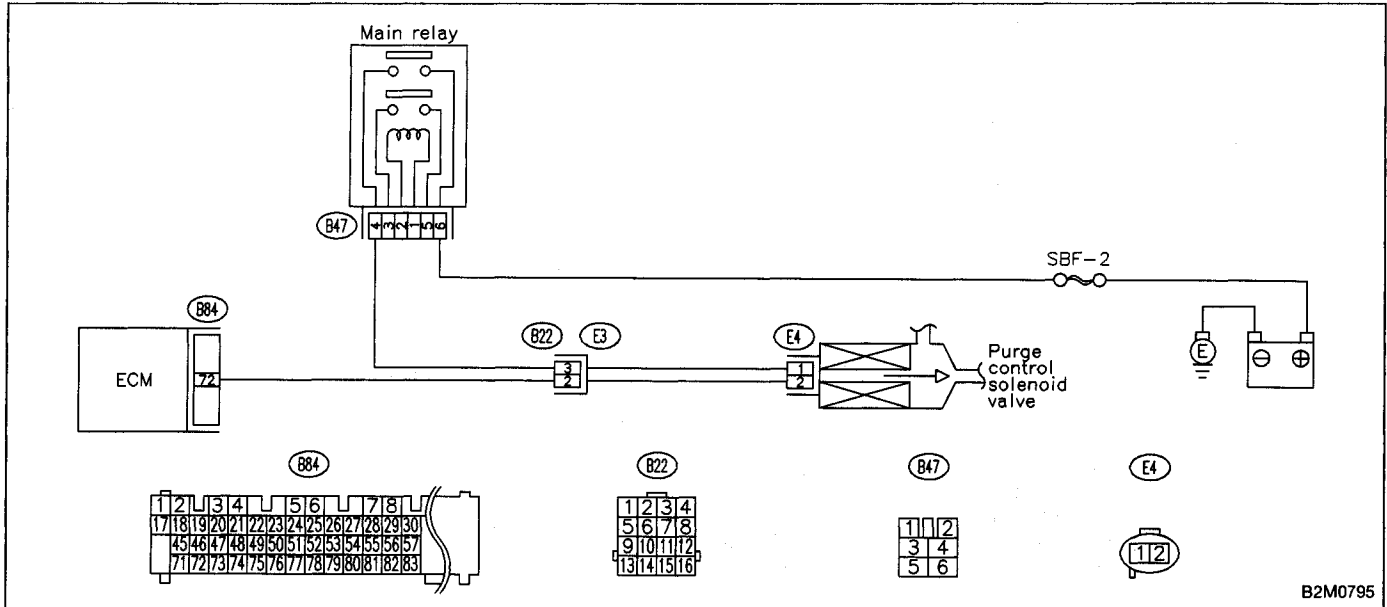

NOTE:

For the diagnostic procedure on evaporative emission control system incorrect purge flow (DTC P0441), refer to 2-7 [T10AE0]☆2.

AF: DTC P0443
— EVAPORATIVE EMISSION CONTROL
SYSTEM PURGE CONTROL VALVE CIRCUIT
MALFUNCTION (CPC) —

WIRING DIAGRAM:

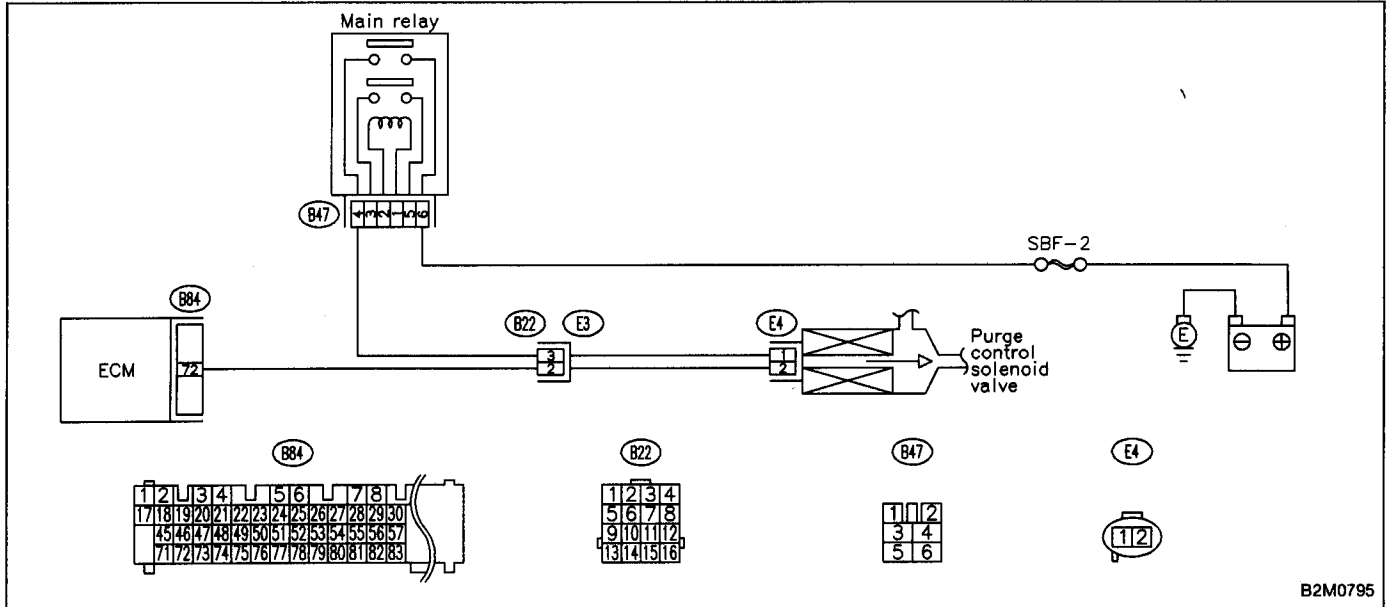

NOTE:

For the diagnostic procedure on evaporative emission control system purge control valve circuit malfunction (DTC P0443), refer to 2-7 [T10AF0]☆2.

AG: DTC P0500
— VEHICLE SPEED SENSOR MALFUNCTION (VSP) —

WIRING DIAGRAM:

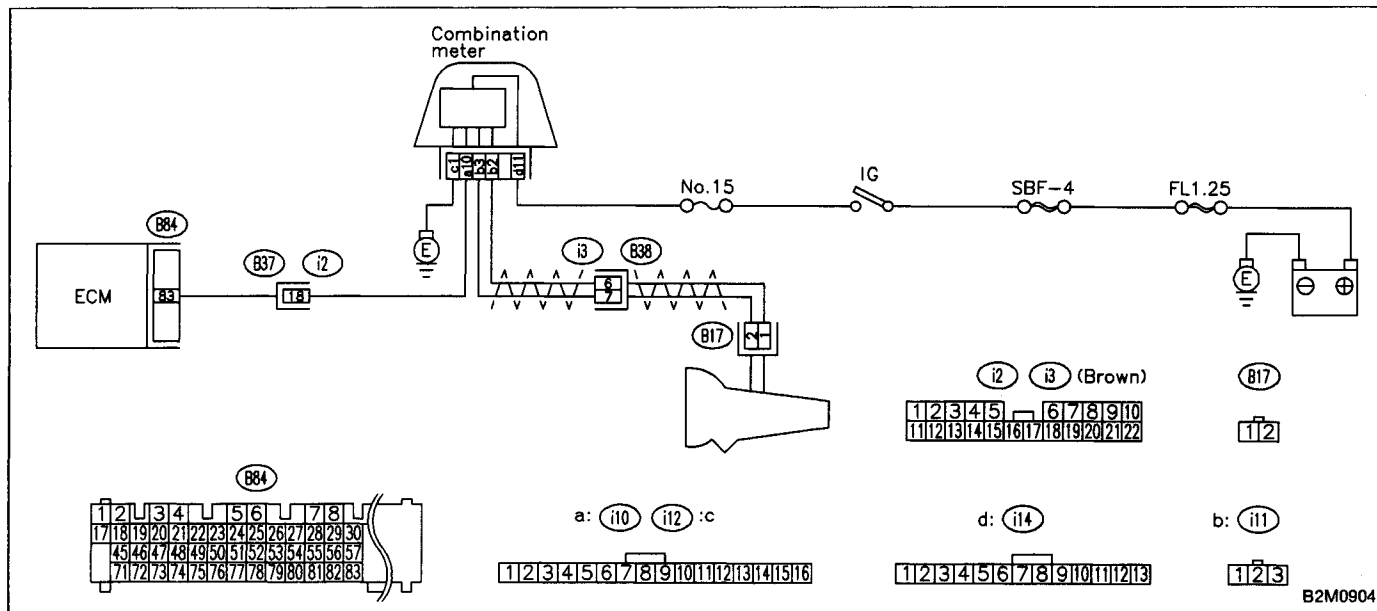

NOTE:
 For the diagnostic procedure on vehicle speed sensor malfunction (DTC P0500), refer to 2-7 [T10AG0]☆2.

AH: DTC P0505
— IDLE CONTROL SYSTEM MALFUNCTION (ISC) —

WIRING DIAGRAM:

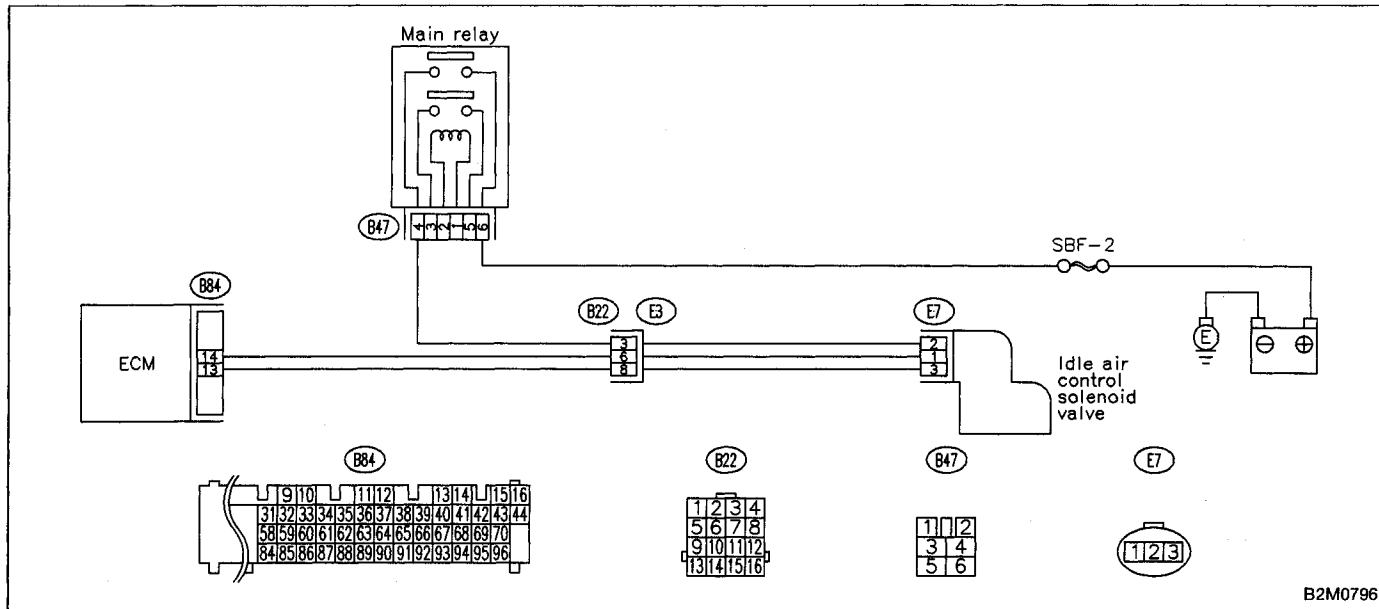

NOTE:
 For the diagnostic procedure on idle control system malfunction (DTC P0505), refer to 2-7 [T10AH0]☆2.

**AI: DTC P0506
— IDLE CONTROL SYSTEM RPM LOWER
THAN EXPECTED (ISC — L) —**

NOTE:

For the diagnostic procedure on idle control system RPM lower than expected (DTC P0506), refer to 2-7 [T10A10]☆2.

**AJ: DTC P0507
— IDLE CONTROL SYSTEM RPM HIGHER
THAN EXPECTED (ISC — H) —**

NOTE:

For the diagnostic procedure on idle control system RPM higher than expected (DTC P0507), refer to 2-7 [T10AJ0]☆2.

AK: DTC P0600
— SERIAL COMMUNICATION LINK
MALFUNCTION —

WIRING DIAGRAM:

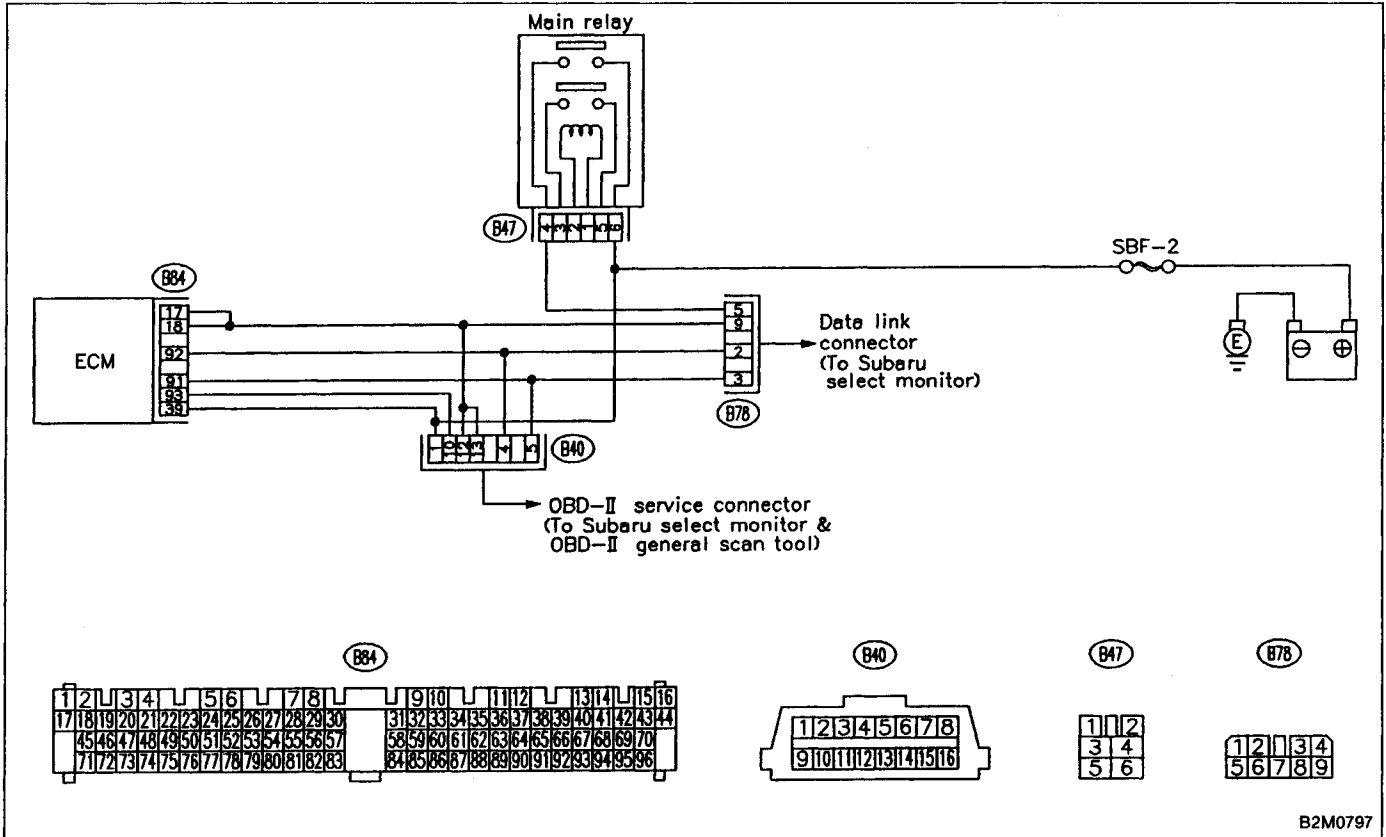

B2M0797

NOTE:
 For the diagnostic procedure on serial communication link malfunction (DTC P0600), refer to 2-7 [T10AK0]☆2.

AL: DTC P0601
— INTERNAL CONTROL MODULE MEMORY
CHECK SUM ERROR (RAM) —

WIRING DIAGRAM:

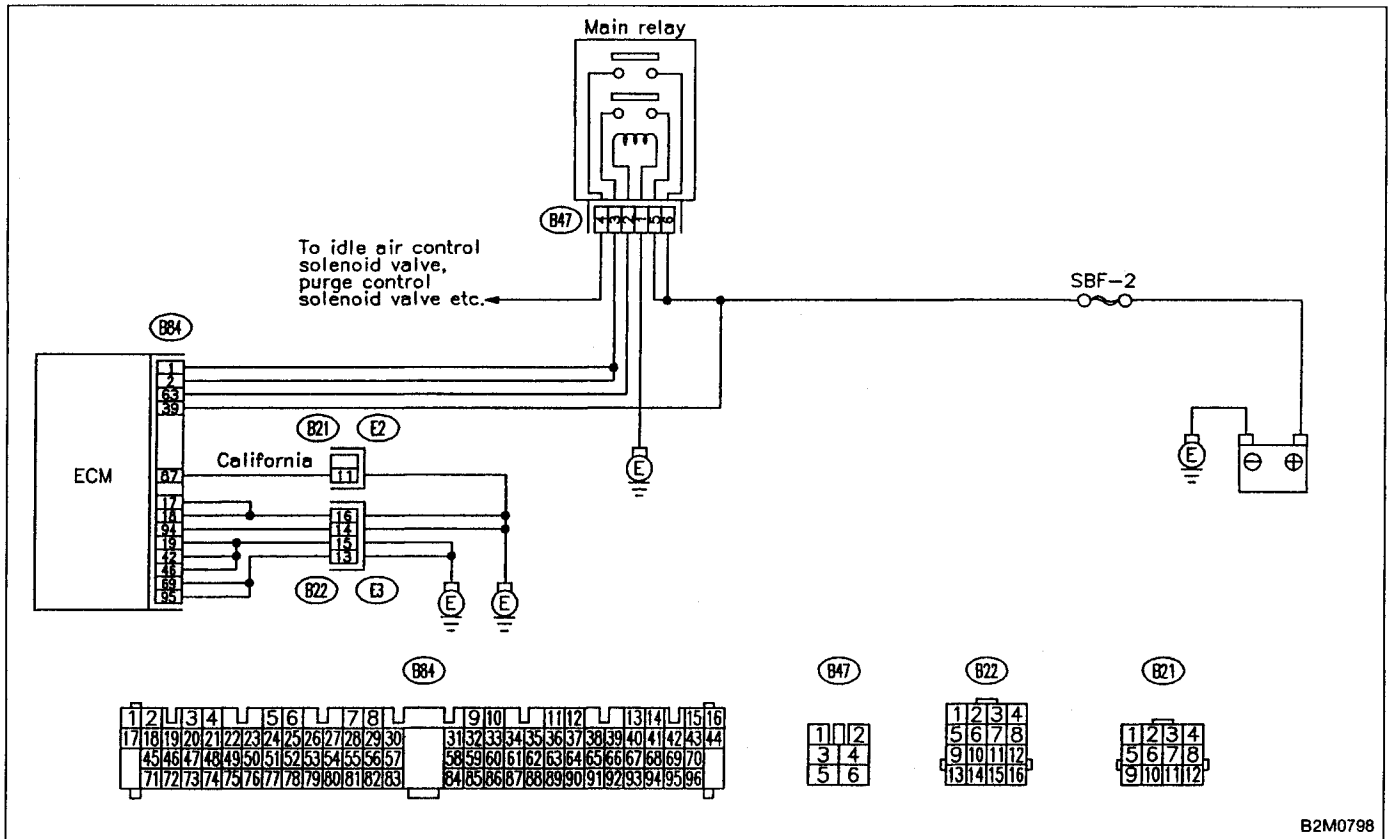

B2M0798

NOTE:

For the diagnostic procedure on internal control module memory check sum error (DTC P0601), refer to 2-7 [T10AL0]☆2.

**AM: DTC P0703
 — BRAKE SWITCH INPUT MALFUNCTION
 (ATBRK) —**

WIRING DIAGRAM:

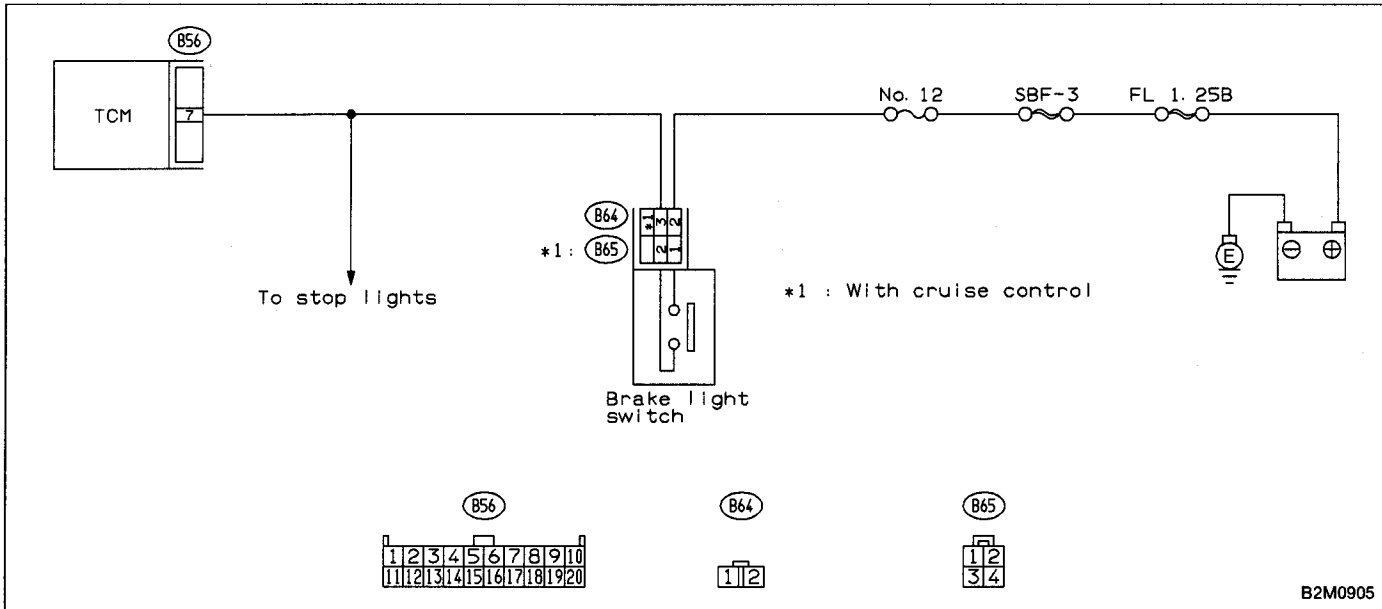

NOTE:

For the diagnostic procedure on brake switch input malfunction (DTC P0703), refer to 2-7 [T10AM0]☆2.

**AN: DTC P0705
 — TRANSMISSION RANGE SENSOR CIRCUIT
 MALFUNCTION (ATRNG) —**

WIRING DIAGRAM:

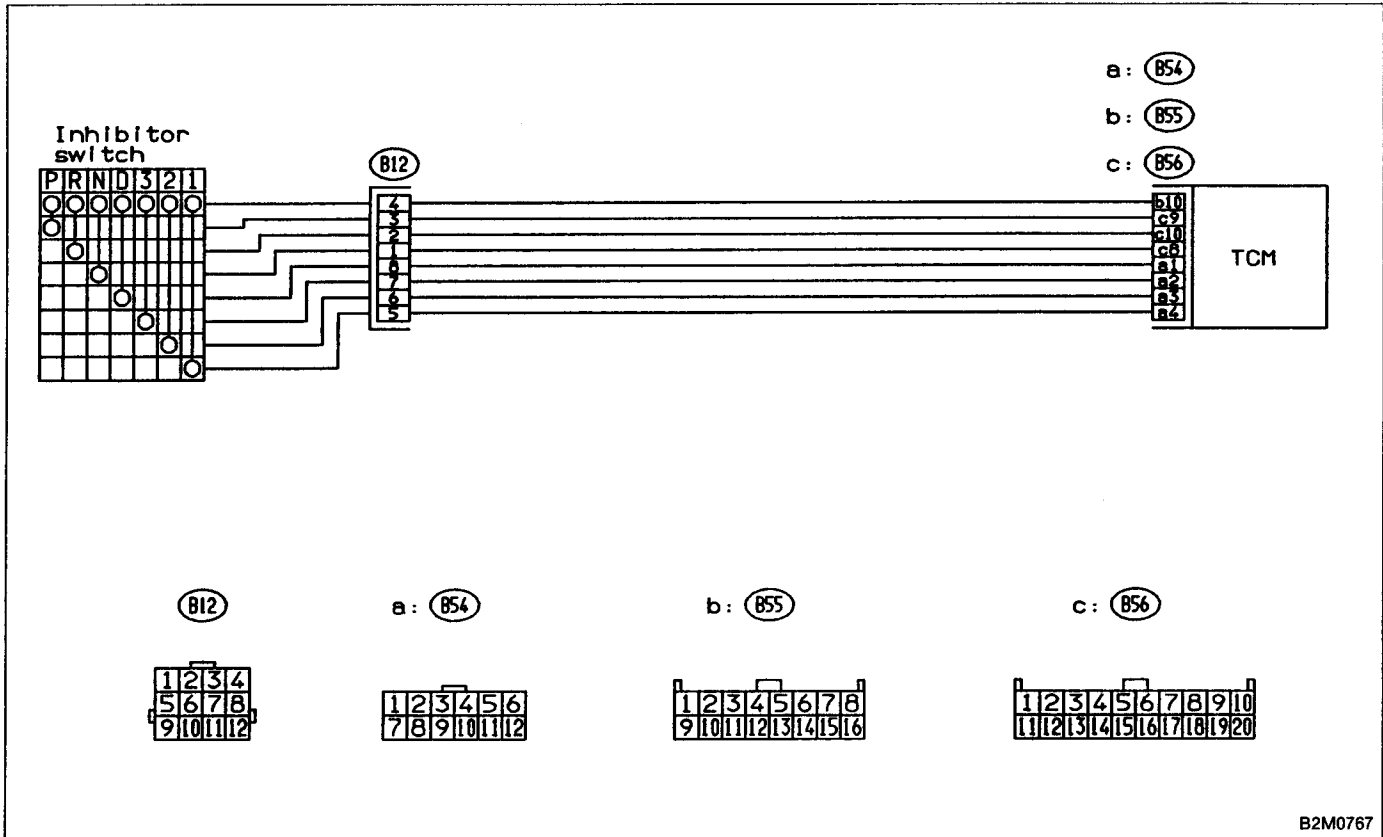

B2M0767

NOTE:

For the diagnostic procedure on transmission range sensor circuit malfunction (DTC P0705), refer to 2-7 [T10AN0]☆2.

AO: DTC P0710
— TRANSMISSION FLUID TEMPERATURE
SENSOR CIRCUIT MALFUNCTION (ATF) —

WIRING DIAGRAM:

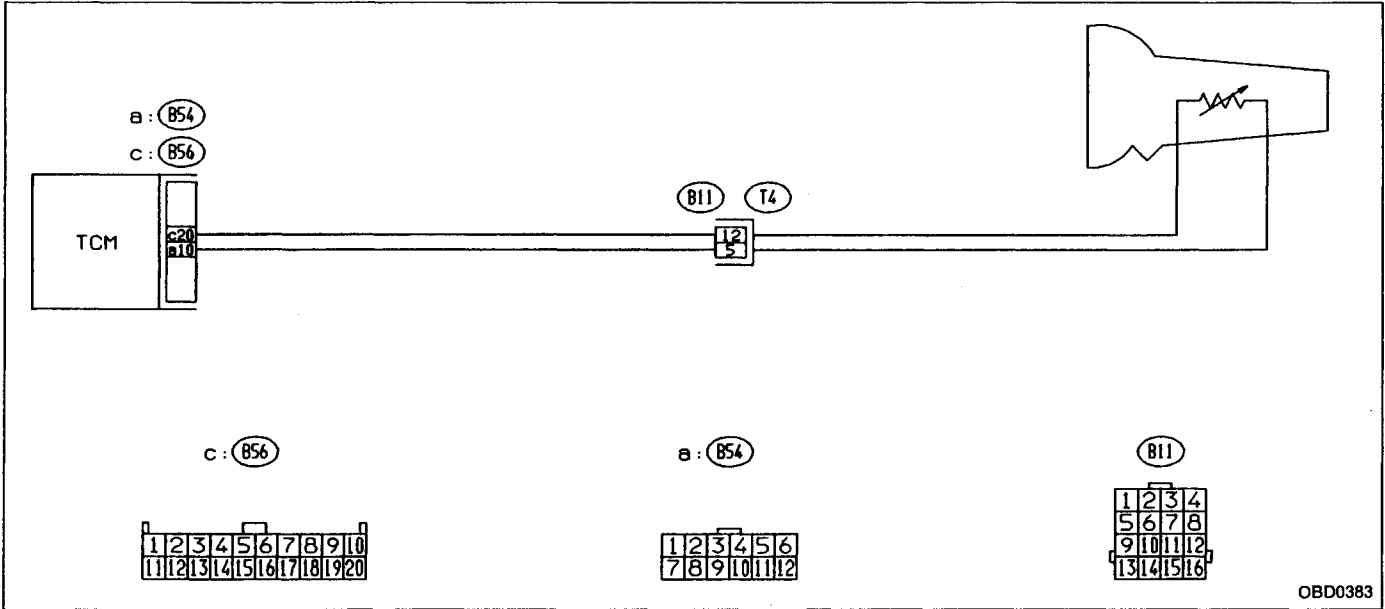

OBD0383

NOTE:

For the diagnostic procedure on transmission fluid temperature sensor circuit malfunction (DTC P0710), refer to 2-7 [T10A00]☆2.

AP: DTC P0720
— OUTPUT SPEED SENSOR (VEHICLE SPEED
SENSOR 1) CIRCUIT MALFUNCTION
(ATVSP) —

WIRING DIAGRAM:

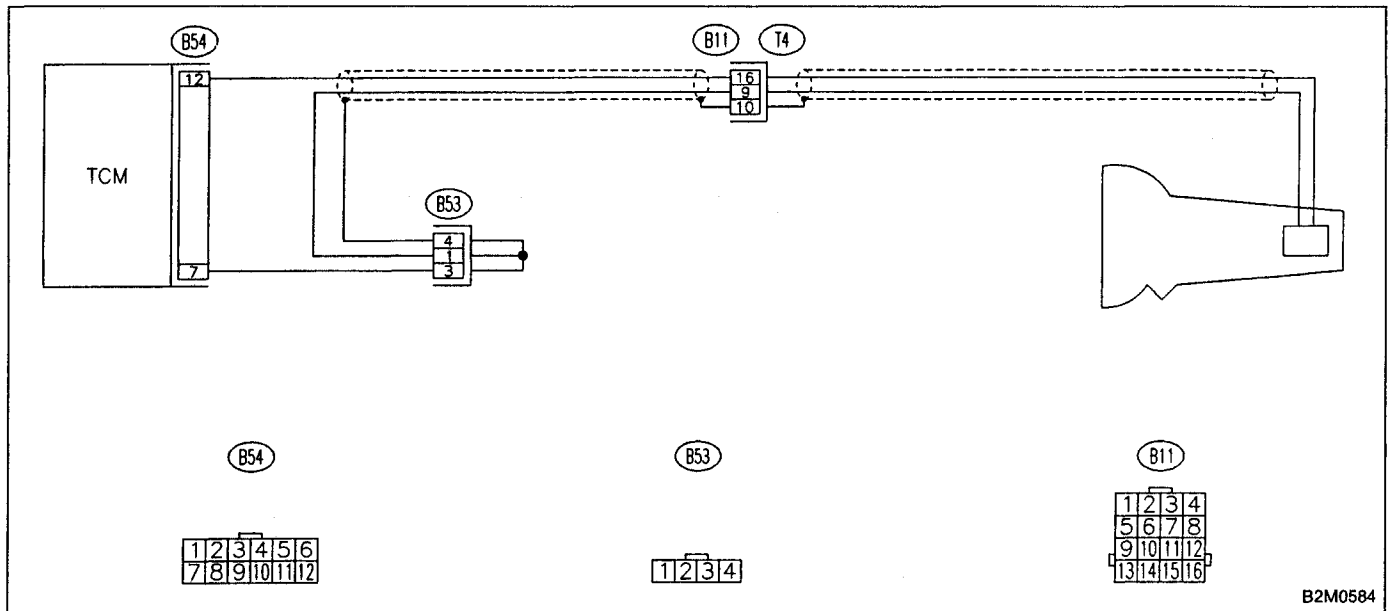

NOTE:
For the diagnostic procedure on output speed sensor (vehicle speed sensor 1) circuit malfunction (DTC P0720), refer to 2-7 [T10AP0]☆2.

AQ: DTC P0725
— ENGINE SPEED INPUT CIRCUIT
MALFUNCTION (ATNE) —

WIRING DIAGRAM:

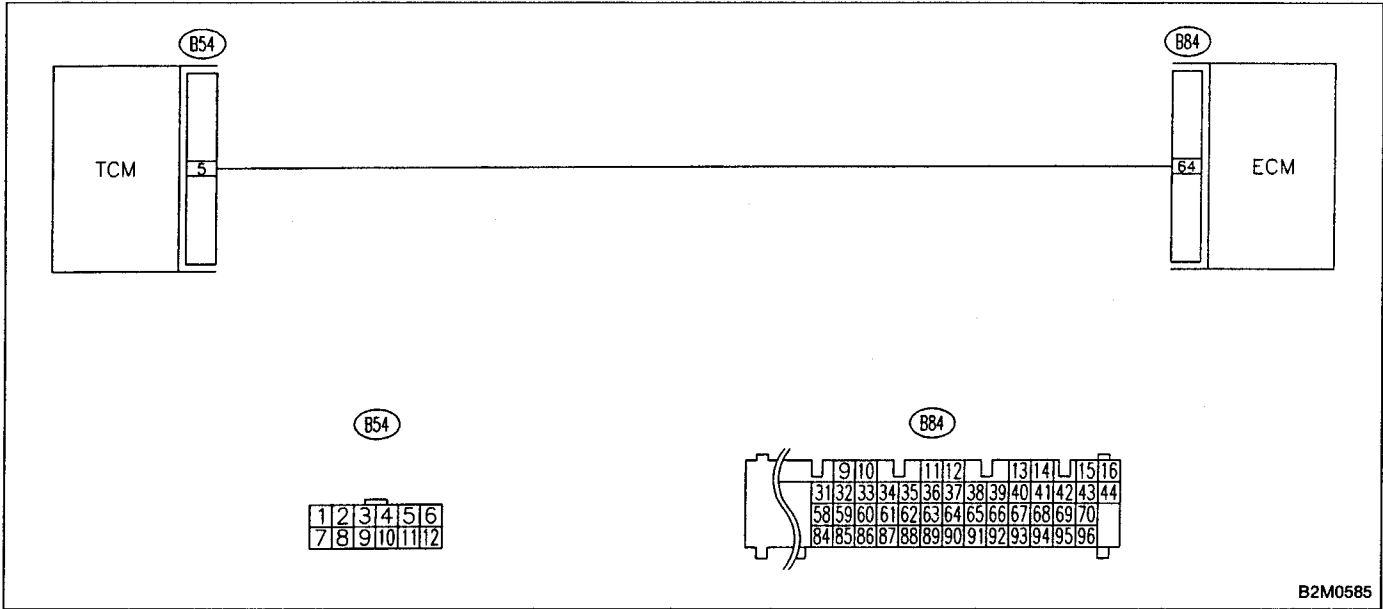

B2M0585

NOTE:

For the diagnostic procedure on engine speed input circuit malfunction (DTC P0725), refer to 2-7 [T10AQ0]☆2.

AR: DTC P0731
— GEAR 1 INCORRECT RATIO (ATGR1) —

AS: DTC P0732
— GEAR 2 INCORRECT RATIO (ATGR2) —

AT: DTC P0733
— GEAR 3 INCORRECT RATIO (ATGR3) —

AU: DTC P0734
— GEAR 4 INCORRECT RATIO (ATGR4) —

WIRING DIAGRAM:

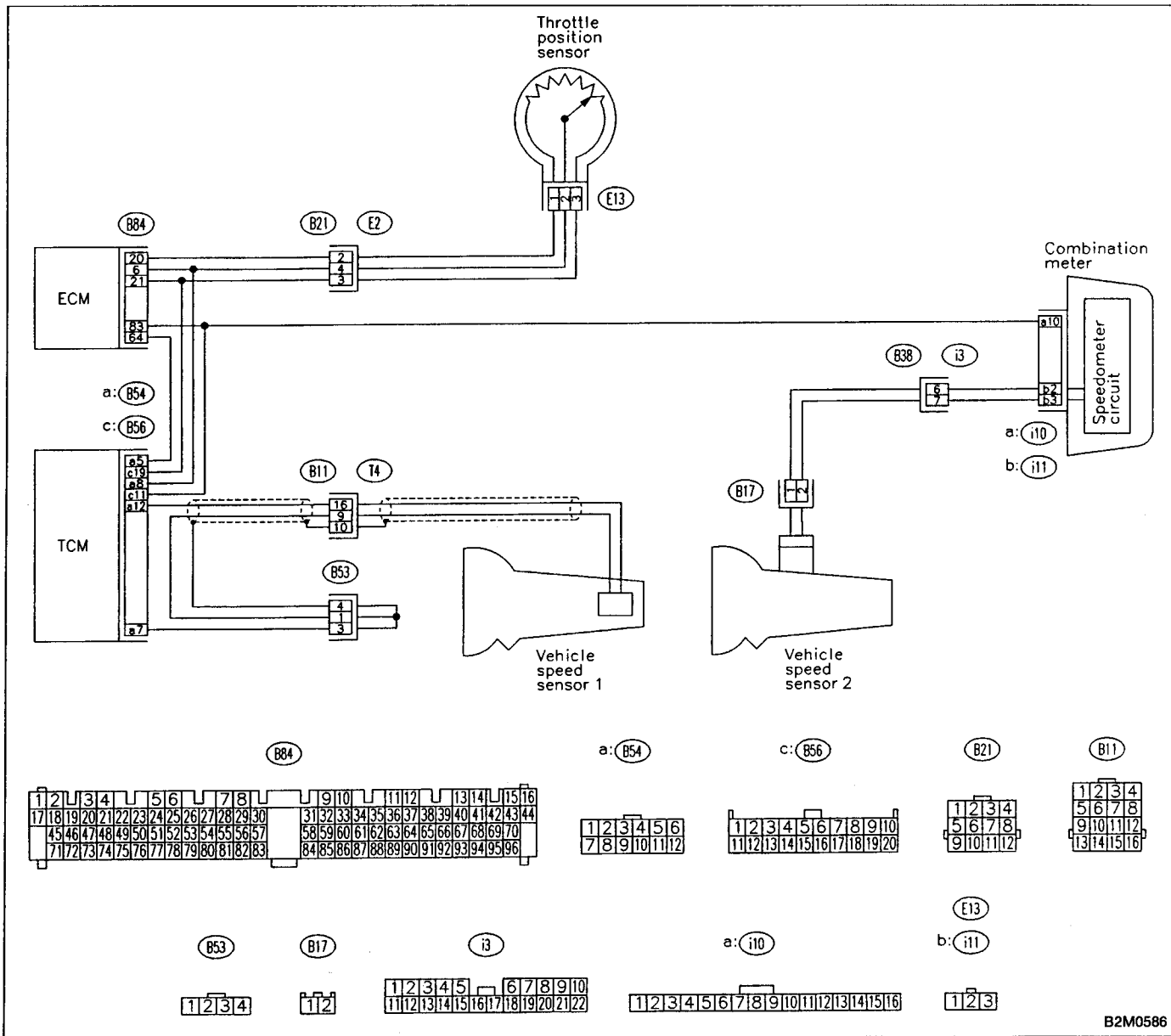

NOTE:

For the diagnostic procedure on gear 1, gear 2, gear 3 and gear 4 incorrect ratio (DTC P0731, DTC P0732, DTC P0733 and DTC P0734), refer to 2-7 [T10AR0, T10AS0, T10AT0 and T10AU0]☆2.

AV: DTC P0740
— TORQUE CONVERTER CLUTCH SYSTEM
MALFUNCTION (ATLU — F) —

WIRING DIAGRAM:

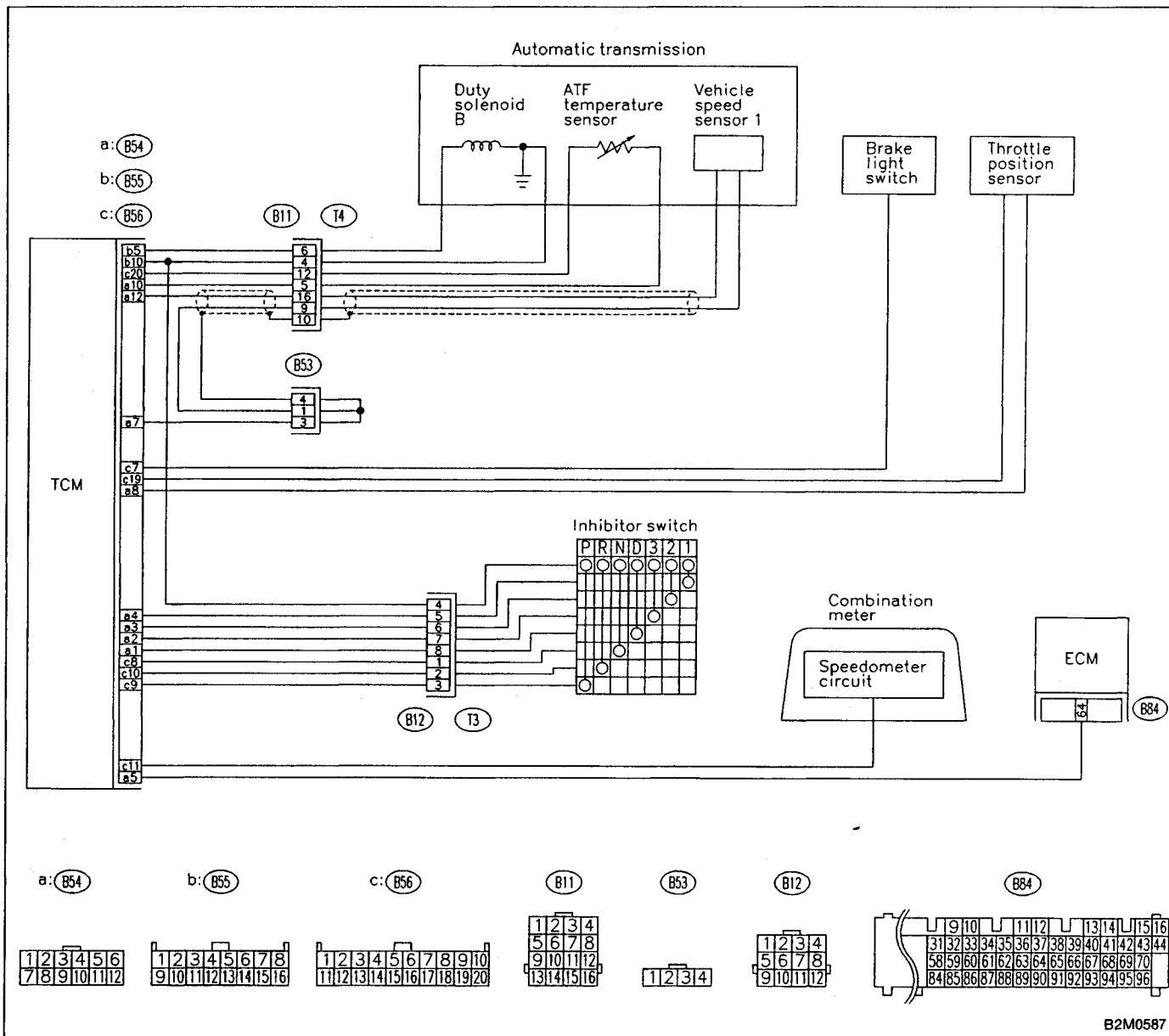

NOTE:

For the diagnostic procedure on torque converter clutch system malfunction (DTC P0740), refer to 2-7 [T10AV0]☆2.

AW: DTC P0743
— TORQUE CONVERTER CLUTCH SYSTEM
(DUTY SOLENOID B) ELECTRICAL (ATLU) —

WIRING DIAGRAM:

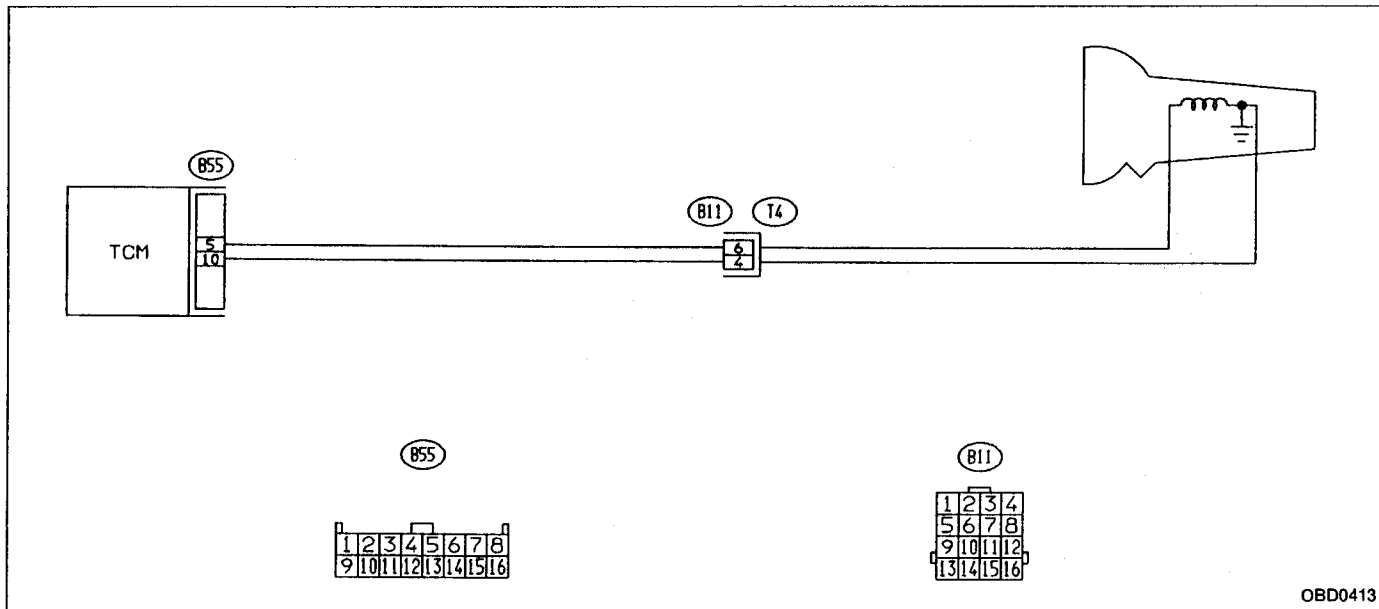

NOTE:

For the diagnostic procedure on torque converter clutch system electrical (DTC P0743), refer to 2-7 [T10AW0]☆2.

AX: DTC P0748
— PRESSURE CONTROL SOLENOID (DUTY SOLENOID A) ELECTRICAL (ATPL) —

WIRING DIAGRAM:

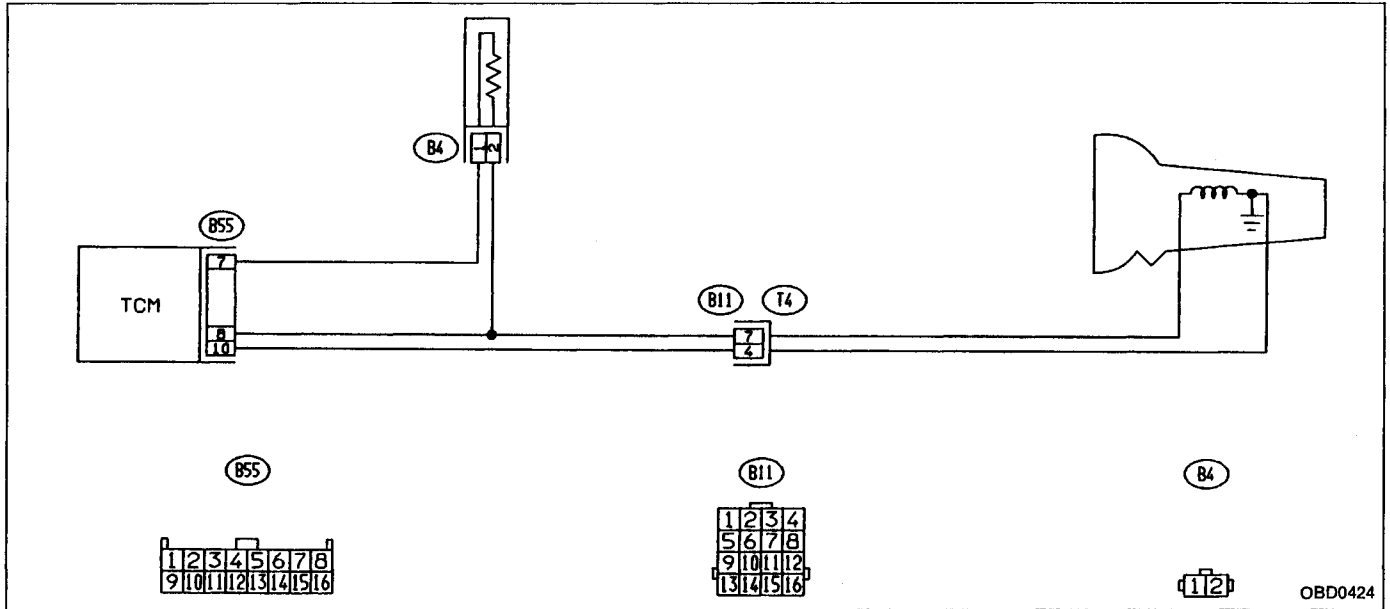

NOTE:
For the diagnostic procedure on pressure control solenoid electrical (DTC P0748), refer to 2-7 [T10AX0]☆2.

AY: DTC P0753
— SHIFT SOLENOID A (SHIFT SOLENOID 1)
ELECTRICAL (ATSFT1) —

WIRING DIAGRAM:

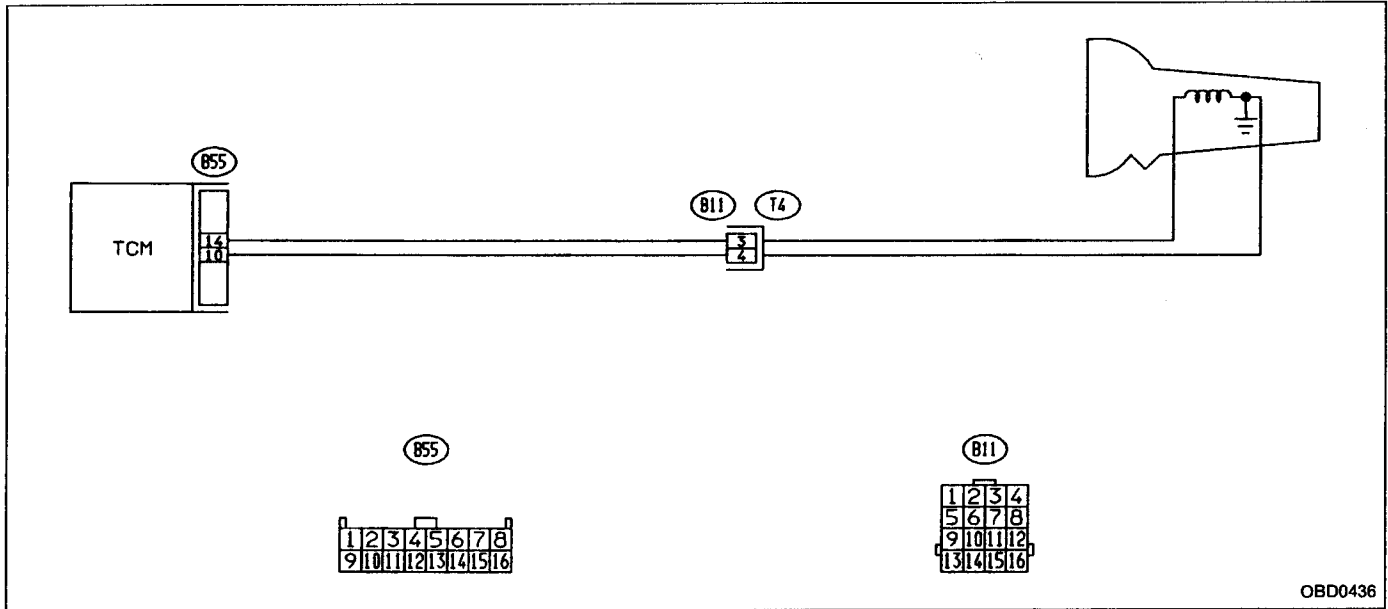

OBD0436

NOTE:
 For the diagnostic procedure on shift solenoid A electrical (DTC P0753), refer to 2-7 [T10AY0]☆2.

AZ: DTC P0758
— SHIFT SOLENOID B (SHIFT SOLENOID 2)
ELECTRICAL (ATSFT2) —

WIRING DIAGRAM:

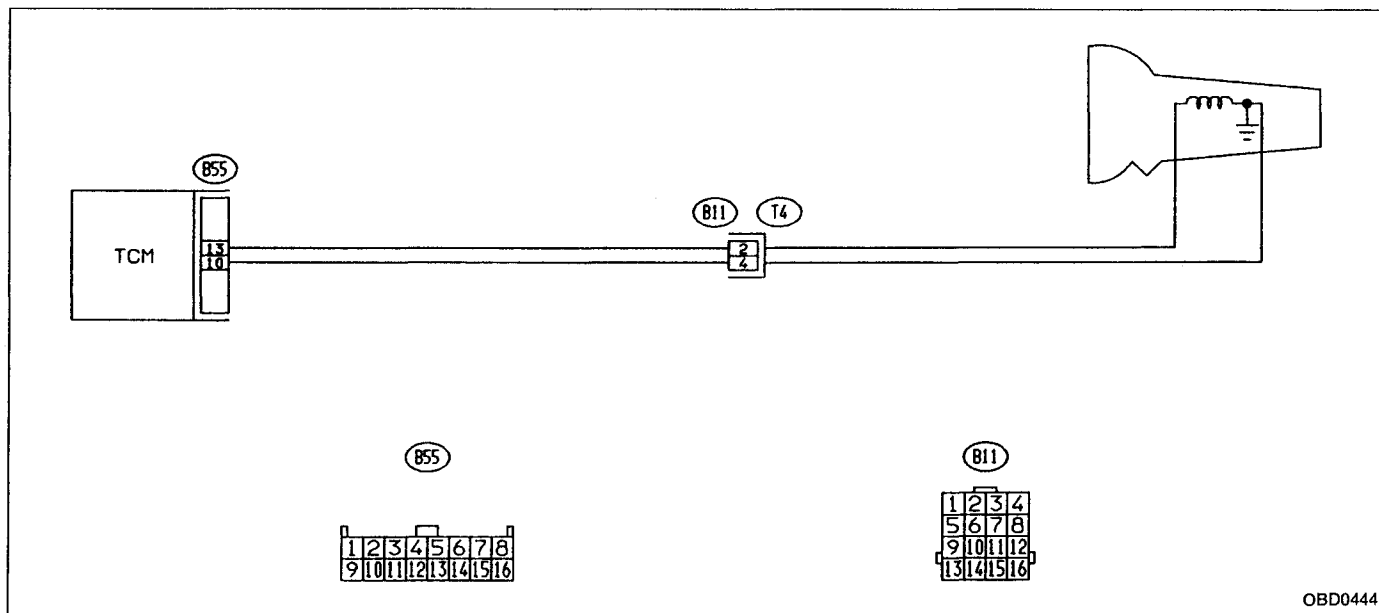

OBD0444

NOTE:
 For the diagnostic procedure on shift solenoid B electrical (DTC P0758), refer to 2-7 [T10AZ0]☆2.

BA: DTC P0760
— SHIFT SOLENOID C (SHIFT SOLENOID 3)
MALFUNCTION (ATOVR — F) —

WIRING DIAGRAM:

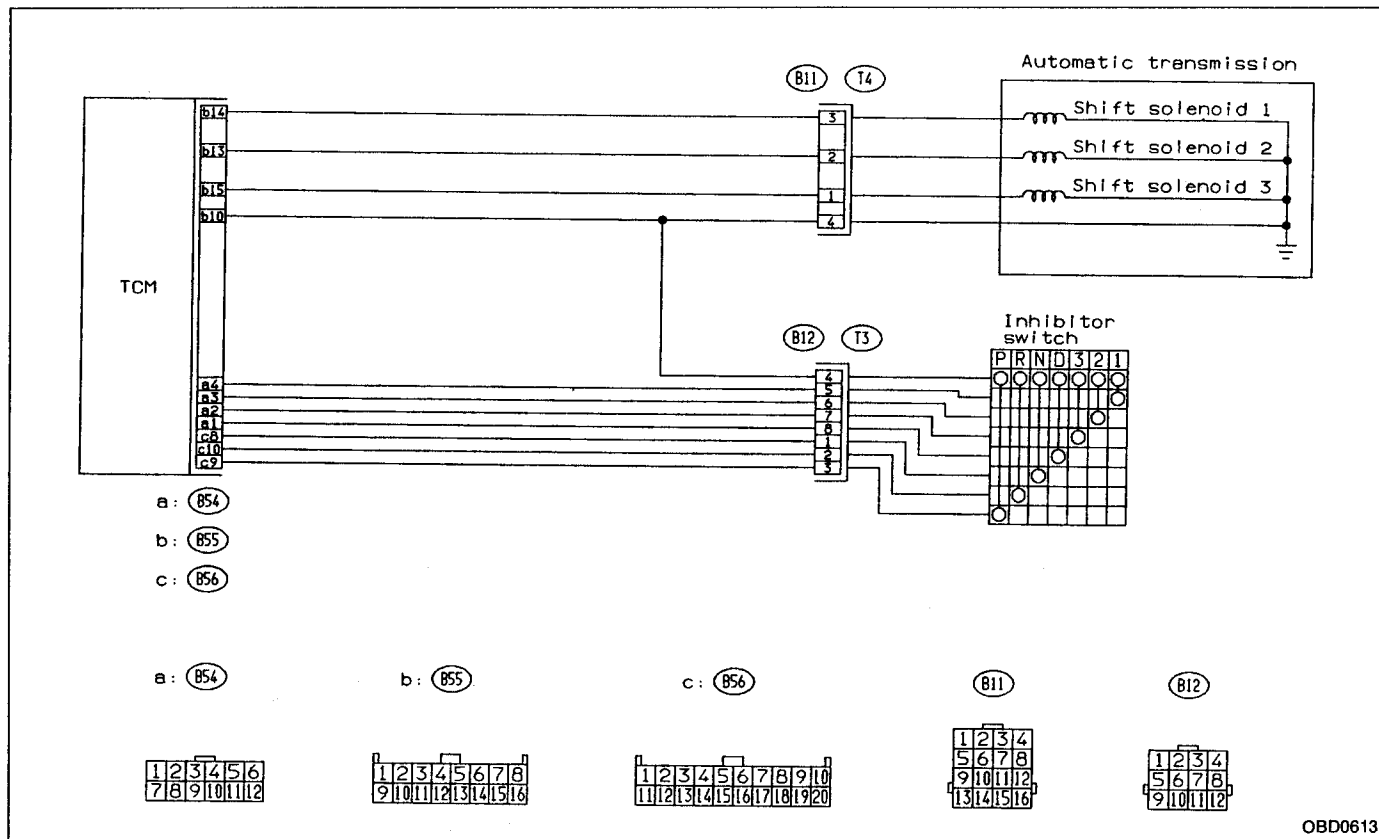

NOTE:
 For the diagnostic procedure on shift solenoid C malfunction (DTC P0760), refer to 2-7 [T10BA0]☆2.

BB: DTC P0763
— SHIFT SOLENOID C (SHIFT SOLENOID 3)
ELECTRICAL (ATOVR) —

WIRING DIAGRAM:

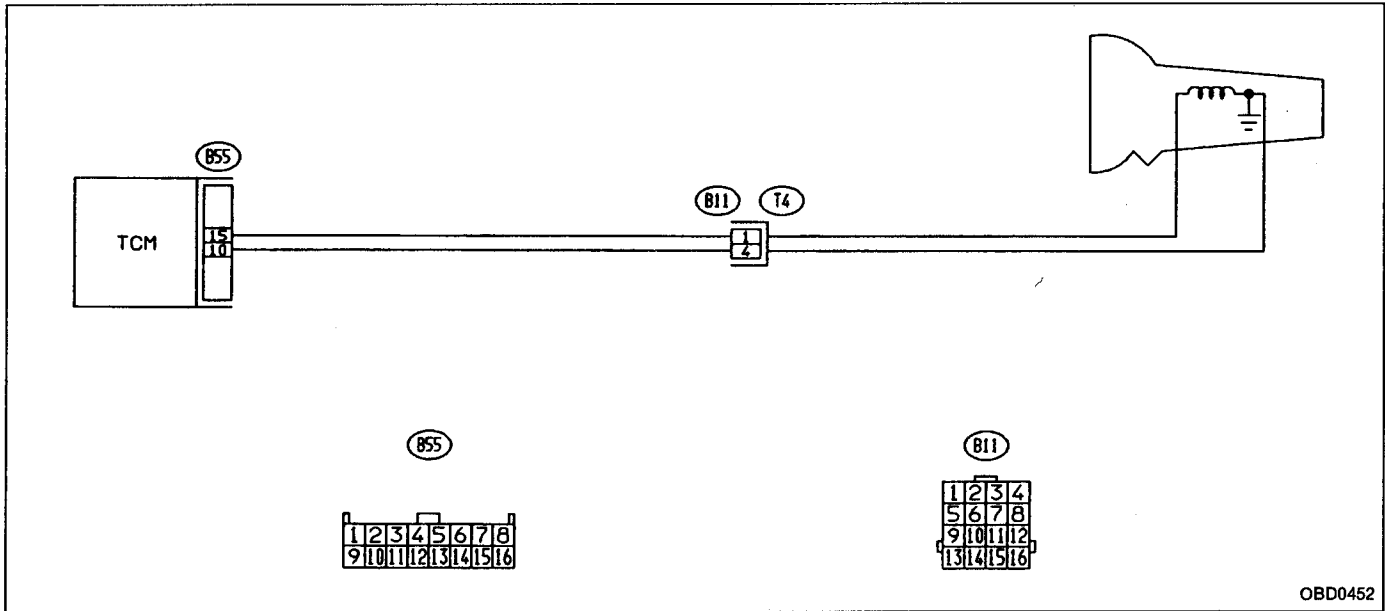

NOTE:
For the diagnostic procedure on shift solenoid C electrical (DTC P0763), refer to 2-7 [T10BB0]☆2.

BC: DTC P1100
— STARTER SWITCH CIRCUIT MALFUNCTION
(ST — SW) —

WIRING DIAGRAM:

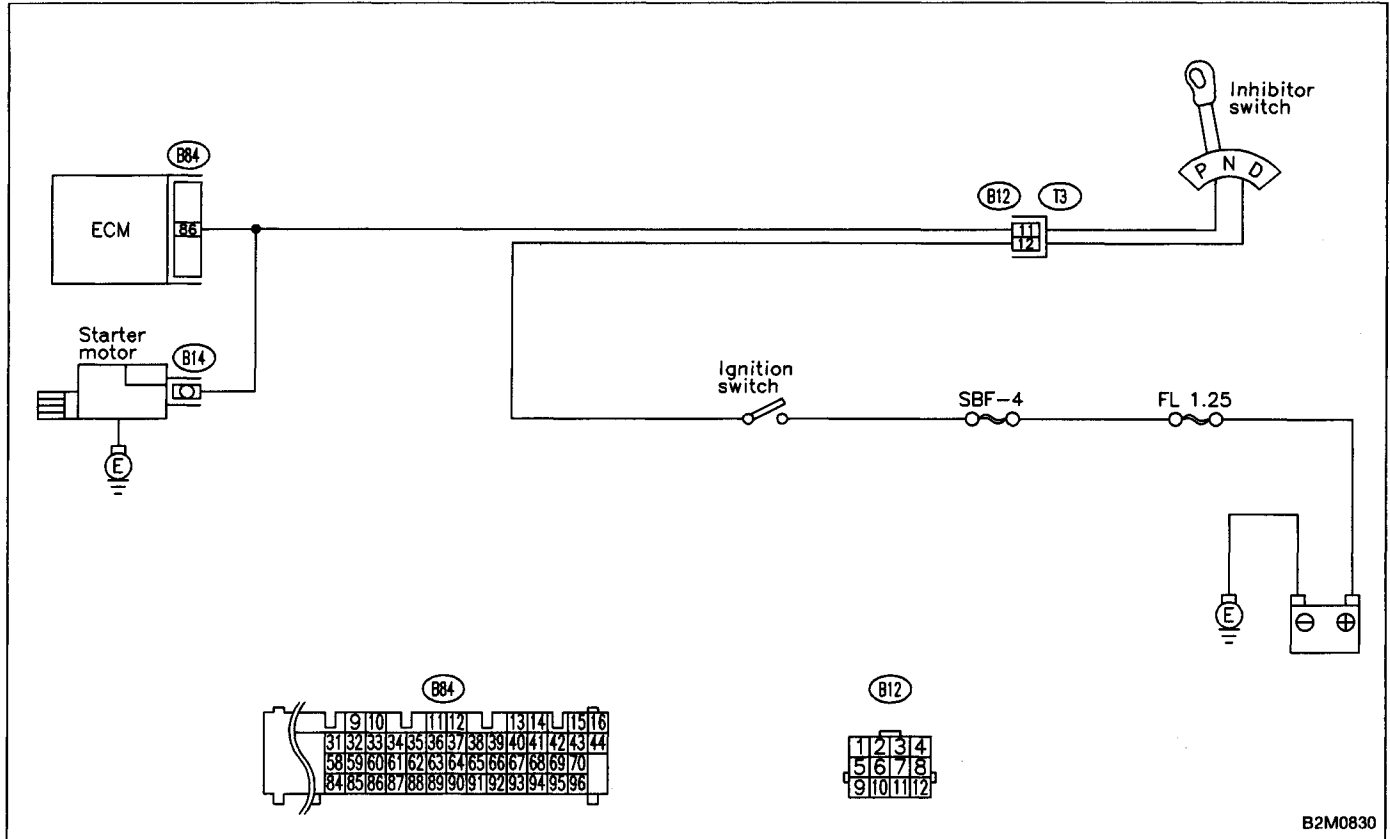

NOTE:
 For the diagnostic procedure on starter switch circuit malfunction (DTC P1100), refer to 2-7 [T10BC0]☆2.

BD: DTC P1101
— NEUTRAL POSITION SWITCH CIRCUIT
MALFUNCTION (N/P — SW) —

WIRING DIAGRAM:

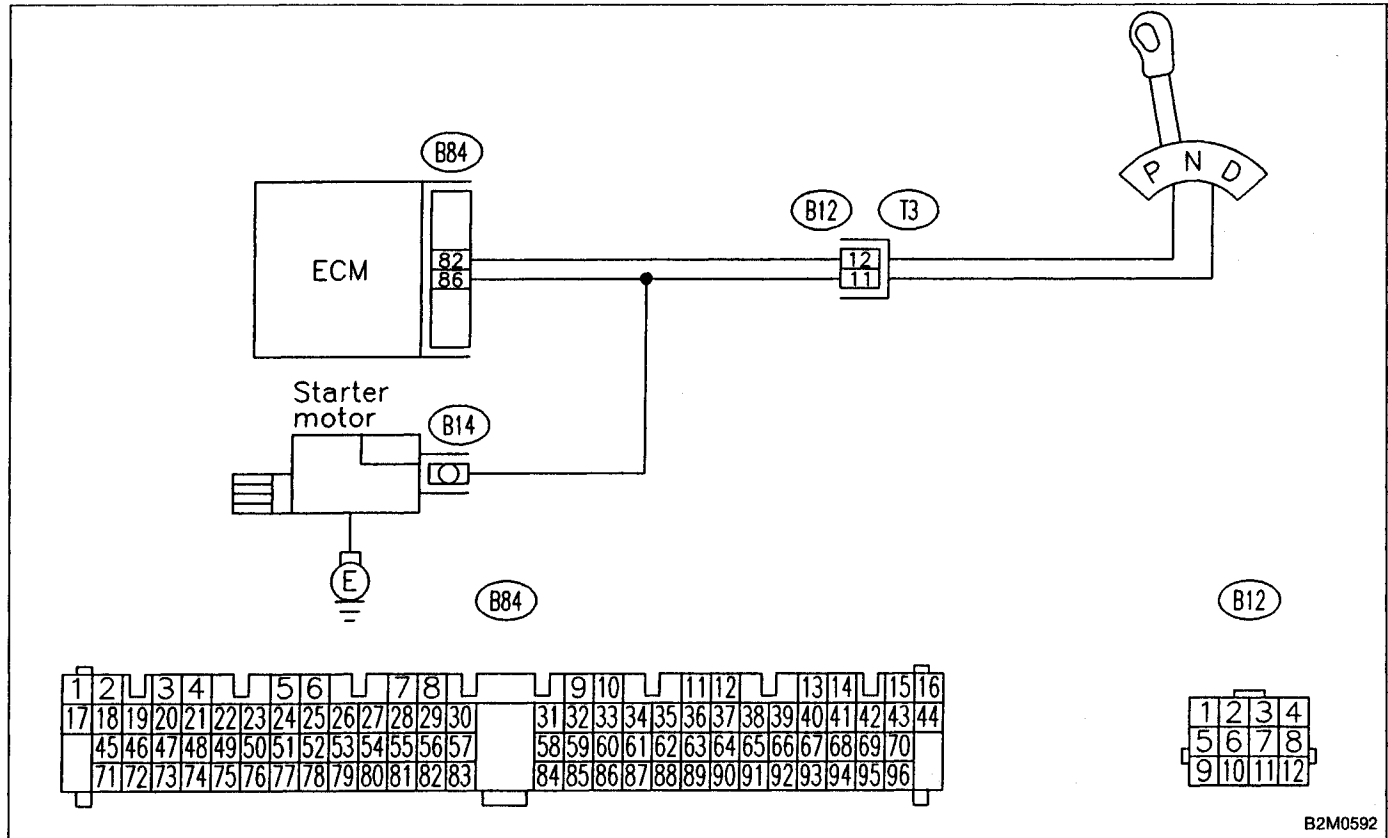

B2M0592

NOTE:

For the diagnostic procedure on neutral position switch circuit malfunction (DTC P1101), refer to 2-7 [T10BE0]☆2.

BE: DTC P1102
— PRESSURE SOURCES SWITCHING
SOLENOID VALVE CIRCUIT MALFUNCTION
(BR) —

WIRING DIAGRAM:

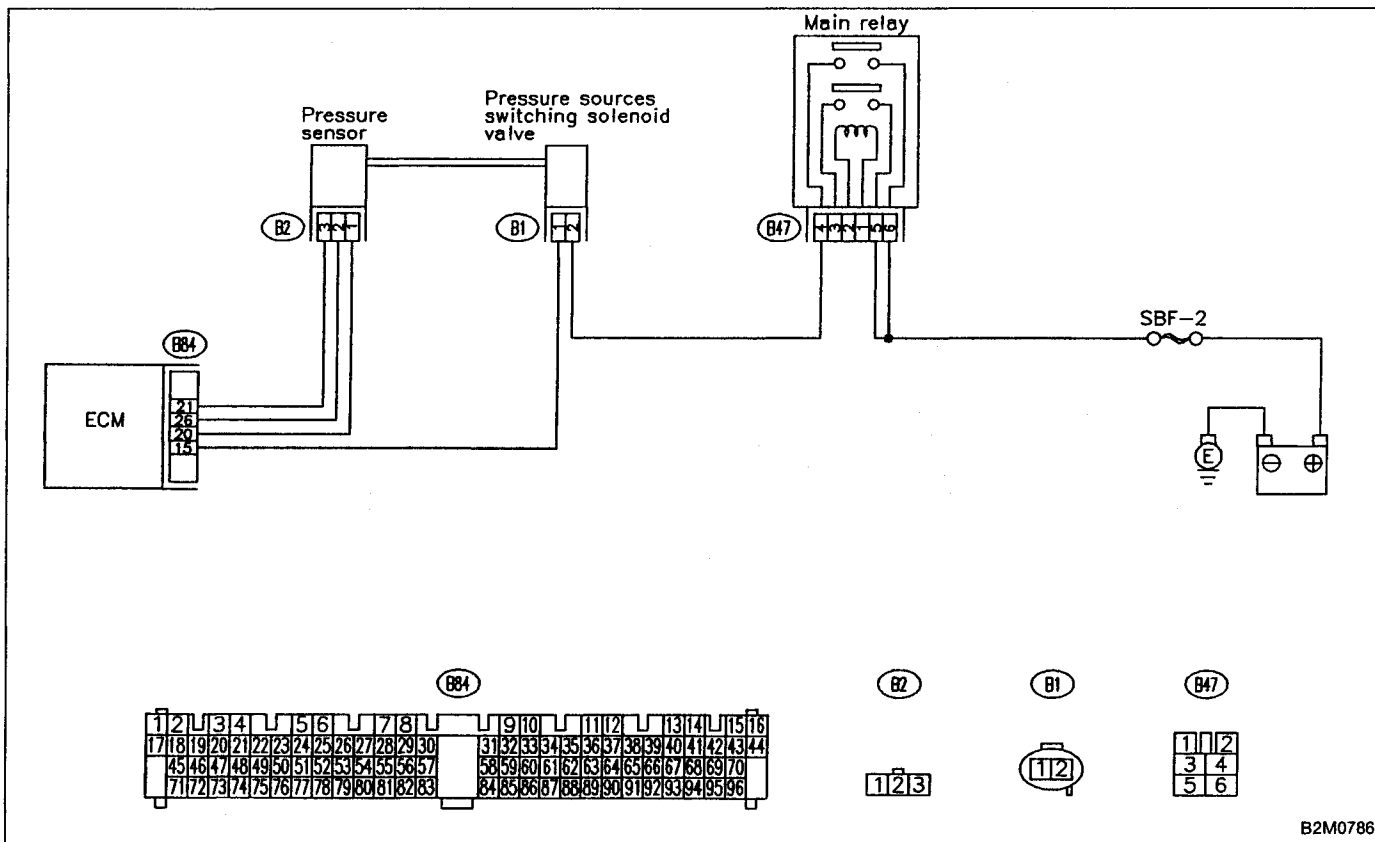

B2M0786

NOTE:

For the diagnostic procedure on pressure sources switching solenoid valve circuit malfunction (DTC P1102), refer to 2-7 [T10BF0]☆2.

**BF: DTC P1103
 — ENGINE TORQUE CONTROL SIGNAL
 CIRCUIT MALFUNCTION (TRQ) —**

WIRING DIAGRAM:

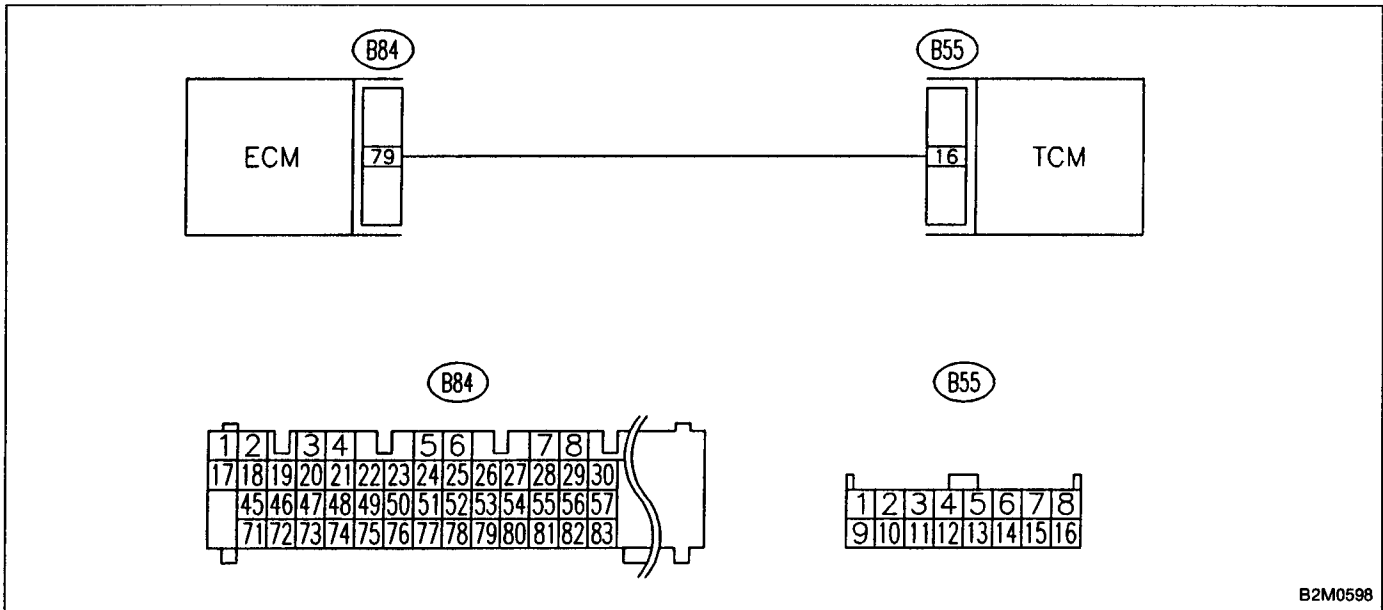

B2M0598

NOTE:

For the diagnostic procedure on engine torque control signal circuit malfunction (DTC P1103), refer to 2-7 [T10BG0]☆2.

**BG: DTC P1500
 — RADIATOR FAN RELAY 1 CIRCUIT
 MALFUNCTION (FAN — 1) —**

WIRING DIAGRAM:

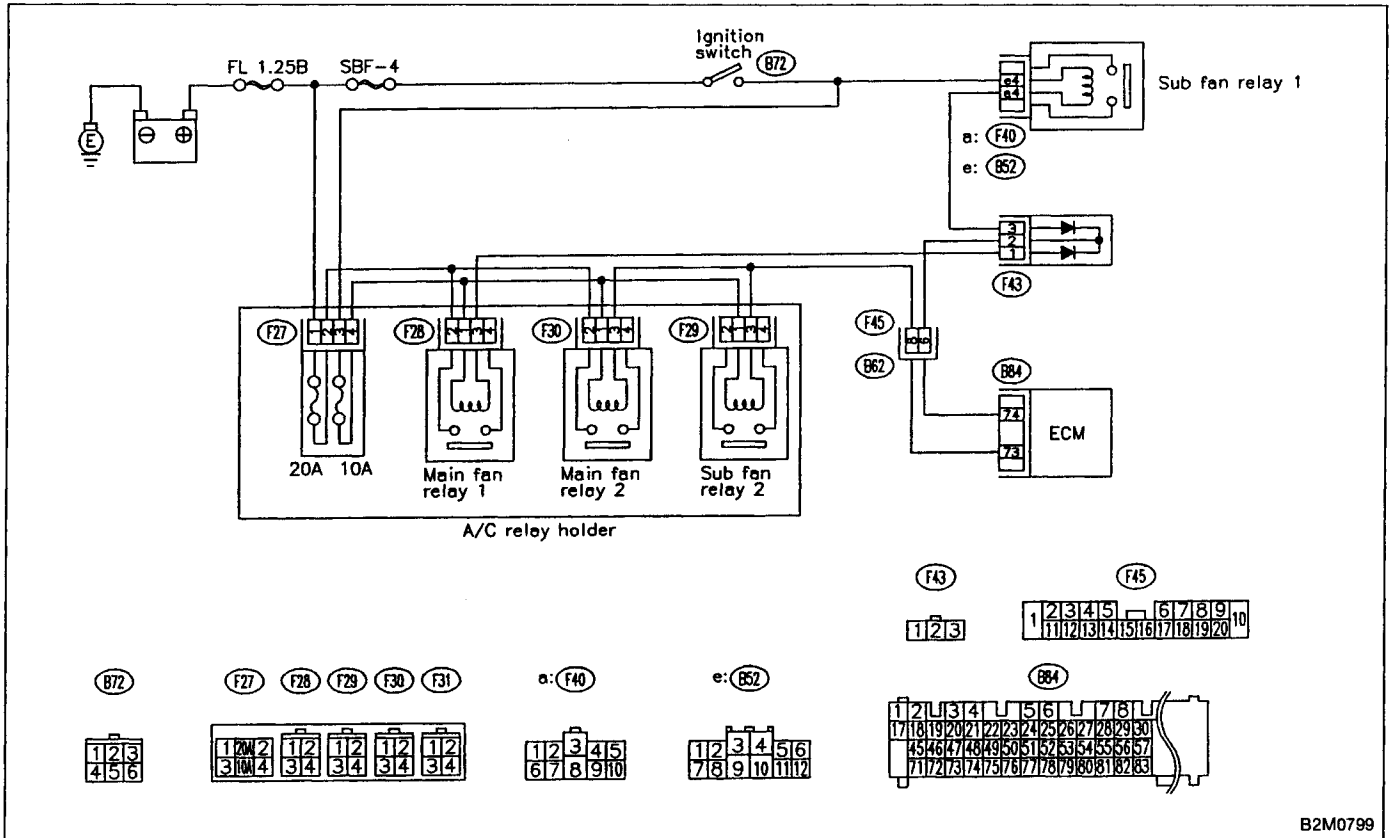

B2M0799

NOTE:
 For the diagnostic procedure on radiator fan relay 1 circuit malfunction (DTC P1500), refer to 2-7 [T10BI0]☆2.

BH: DTC P1502
— RADIATOR FAN FUNCTION PROBLEM
(FAN — F) —

WIRING DIAGRAM:

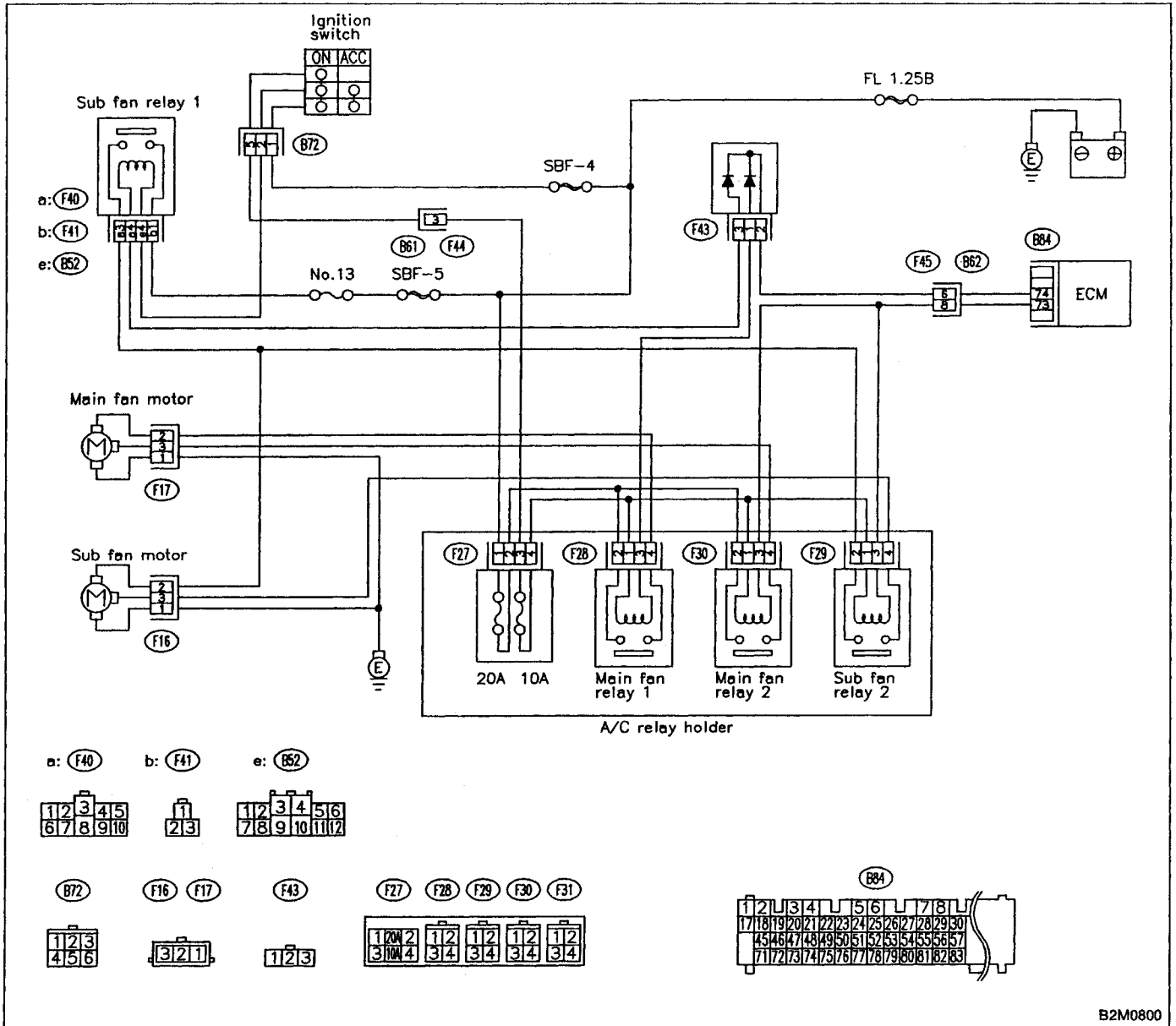

B2M0800

NOTE:
 For the diagnostic procedure on radiator fan function problem (DTC P1502), refer to 2-7 [T10BJ0]☆2.

BI: DTC P1700
— THROTTLE POSITION SENSOR CIRCUIT
MALFUNCTION (ATTH) —

WIRING DIAGRAM:

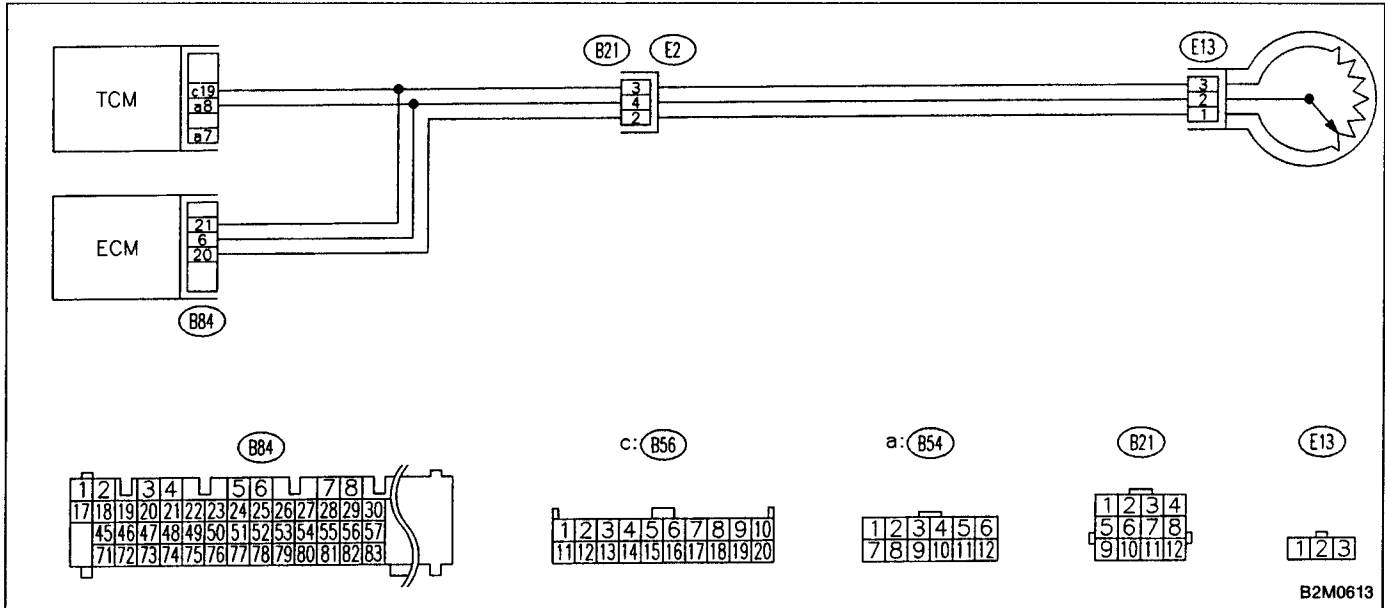

NOTE:

For the diagnostic procedure on throttle position sensor circuit malfunction (DTC P1700), refer to 2-7 [T10BK0]☆2.

BJ: DTC P1701
— CRUISE CONTROL SET SIGNAL CIRCUIT
MALFUNCTION (ATCRS) —

WIRING DIAGRAM:

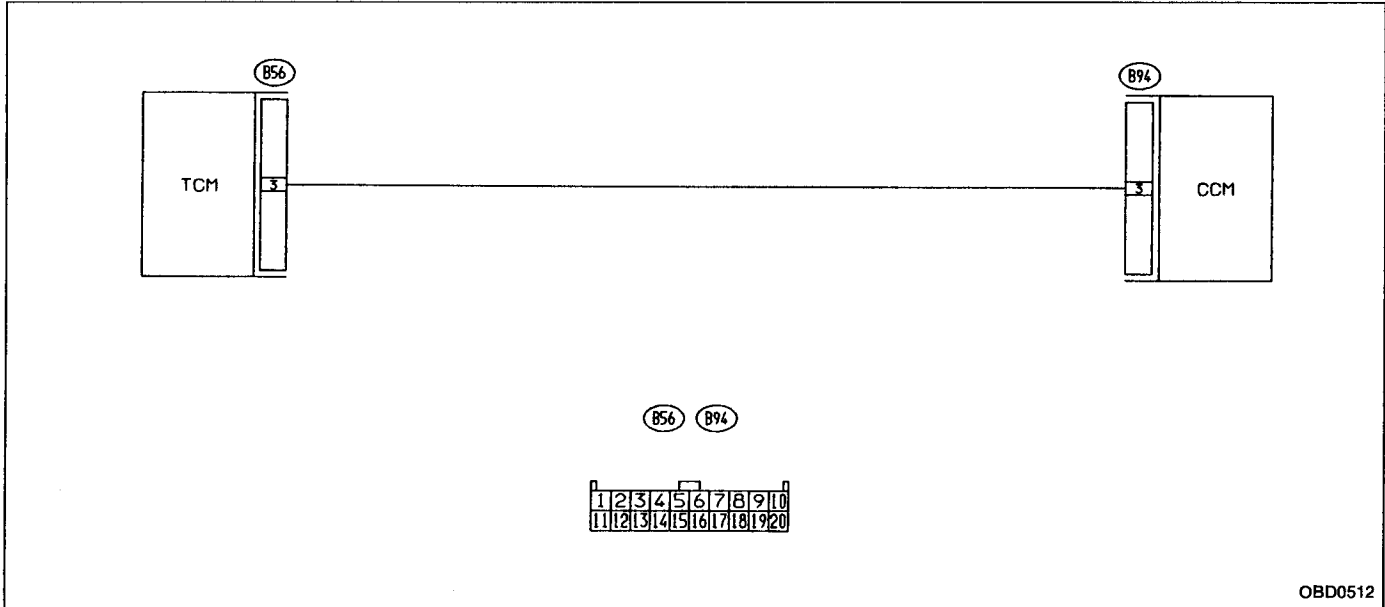

NOTE:
 For the diagnostic procedure on cruise control set signal circuit malfunction (DTC P1701), refer to 2-7 [T10BL0]☆2.

BK: DTC P1702
— AUTOMATIC TRANSMISSION DIAGNOSIS
INPUT SIGNAL CIRCUIT MALFUNCTION
(ATDIAG) —

WIRING DIAGRAM:

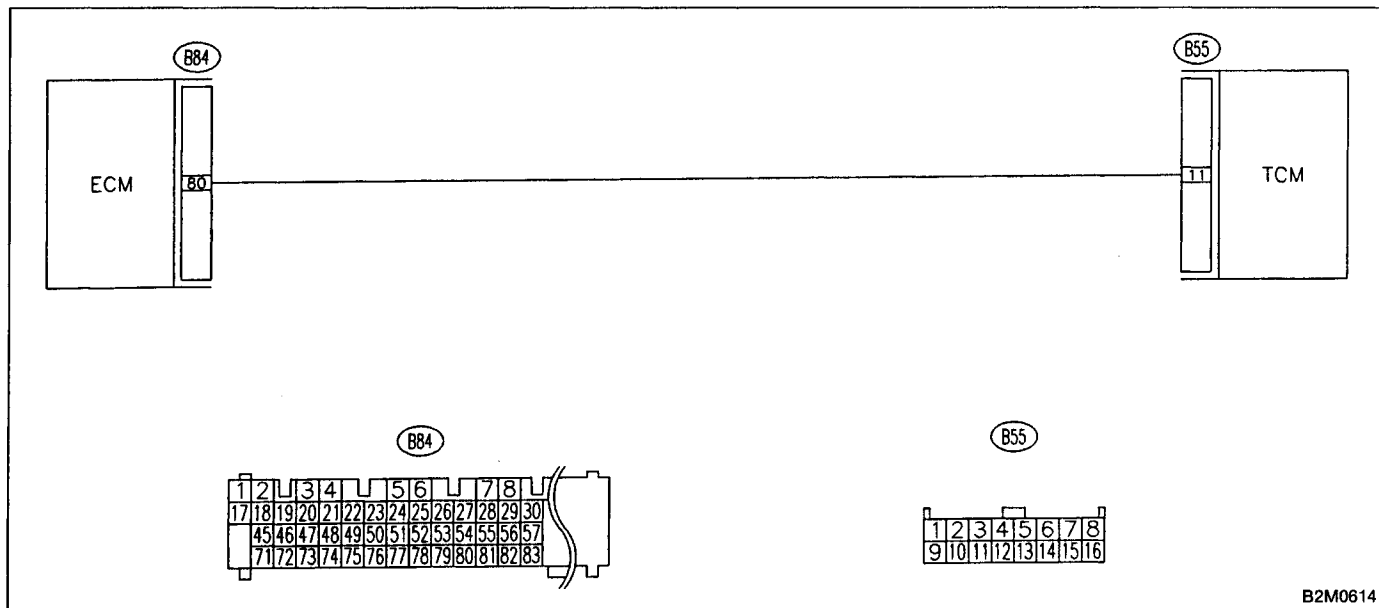

NOTE:
 For the diagnostic procedure on automatic transmission diagnosis input signal circuit malfunction (DTC P1702), refer to 2-7 [T10BM0]☆2.