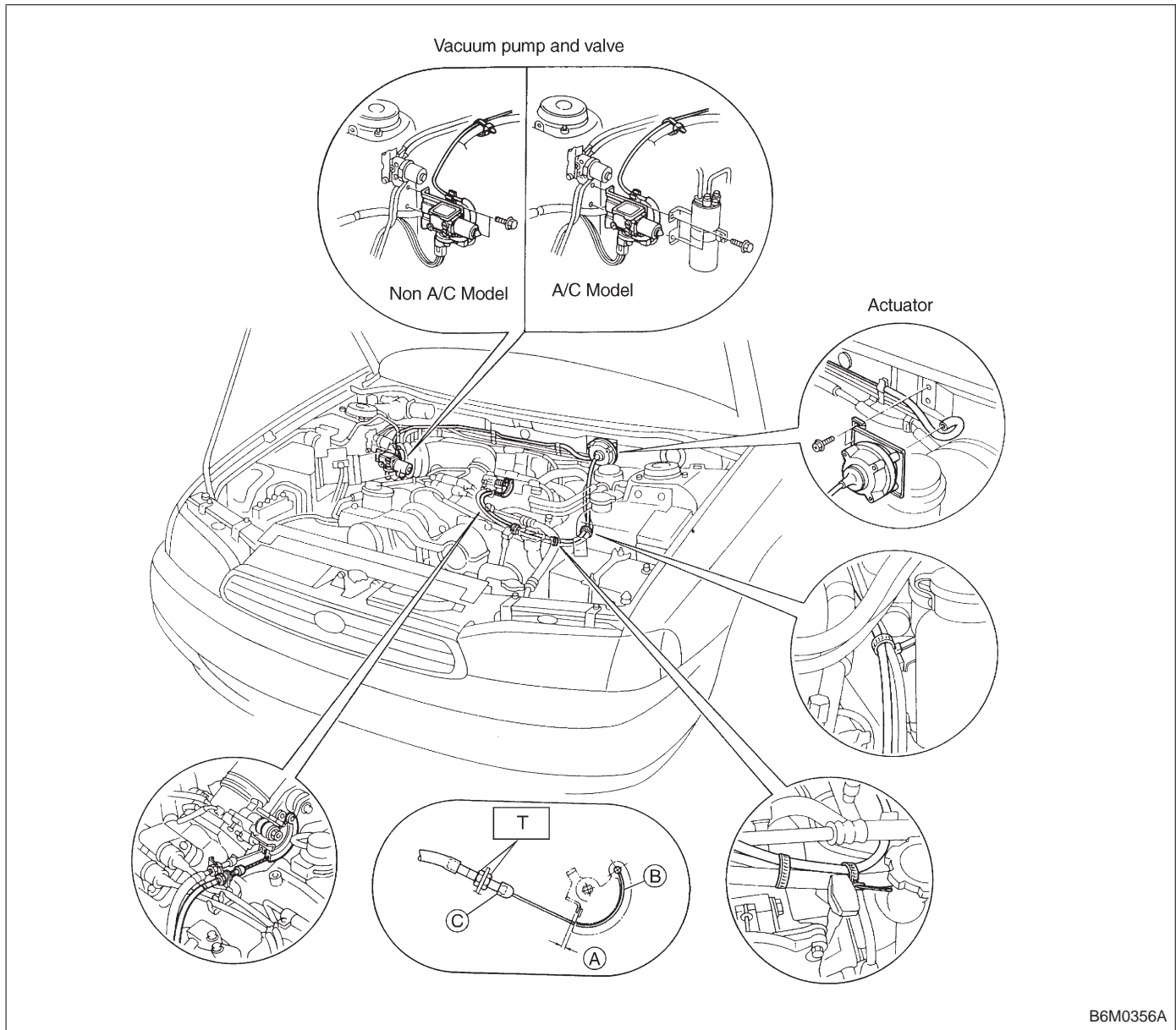

## 21. Cruise Control

### A: ADJUSTMENT

**CAUTION:**

- Ⓐ: Must be adjusted when cable end outer is fixed in place, so that gap between throttle cam and lever is  $1.0_{-1}^0$  mm ( $0.04_{-0.04}^0$  in). (Must be attached while throttle cam is being pulled by wire cable.)
- Ⓑ: Must be coated evenly on cam end inner connection.
- Ⓒ: Cover must be inserted securely, until tip of cable touches cover stopper.

**Tightening torque: N·m (kg·m, ft·lb)**

**T: 6.4 — 11.3 (0.65 — 1.15, 4.7 — 8.3)**

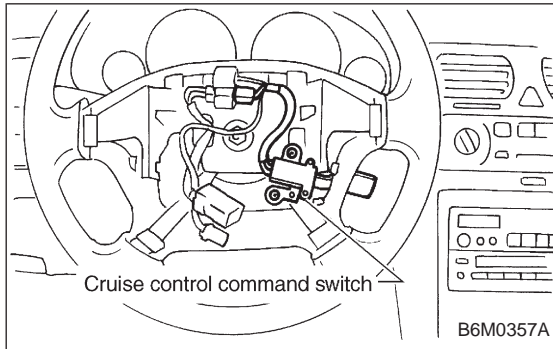
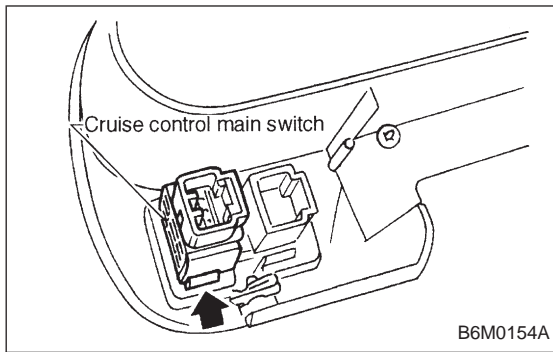

## B: REMOVAL AND INSTALLATION

### 1. CRUISE CONTROL MAIN SWITCH

- 1) Remove screws which secure meter visor.
- 2) Remove meter visor from instrument panel while disconnecting connectors.
- 3) Remove cruise control main switch from meter visor.

### 2. CRUISE CONTROL COMMAND SWITCH

- 1) Remove screw which secures horn pad to the base of steering wheel.
- 2) Remove horn pad from steering wheel while disconnecting connector.
- 3) Disconnect connector of cruise control command switch.
- 4) Remove screws which secure cruise control command switch to steering wheel, and then remove command switch.

#### **WARNING:**

Refer to 5-5 when removing or installing the module from the airbag equipped model.

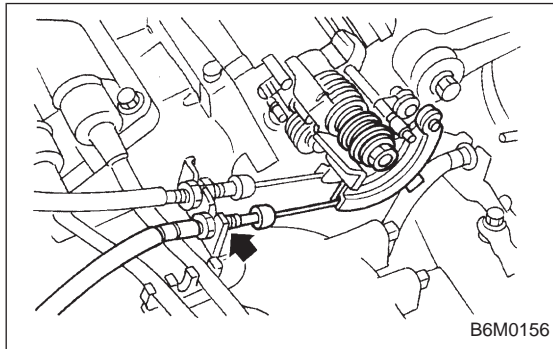

### 3. ACTUATOR

- 1) Loosen nut which secures cruise control cable end to throttle cam, and then remove cable from engine throttle cam.
- 2) Remove clip bands from cruise control cable.

#### **CAUTION:**

- Be careful not to apply excessive load to the wire cable when adjusting and/or installing; otherwise, the actuator may be deformed or damaged.
- Do not bend cable sharply with a radius less than 100 mm (3.94 in); otherwise, cable may bend permanently, resulting in poor performance.
- When installing cable, be careful not to sharply bend or pinch the inner cable; otherwise, the cable may break.

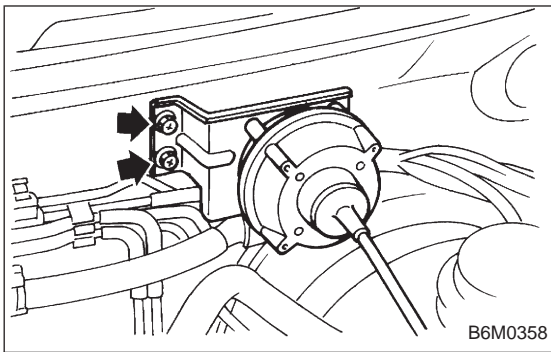

- 3) Remove nuts which secure actuator.
- 4) Remove actuator while disconnecting vacuum hose.

**Tightening torque:**

**$7.4 \pm 1.5 \text{ N}\cdot\text{m}$  ( $0.75 \pm 0.15 \text{ kg}\cdot\text{m}$ ,  $5.4 \pm 1.1 \text{ ft}\cdot\text{lb}$ )**

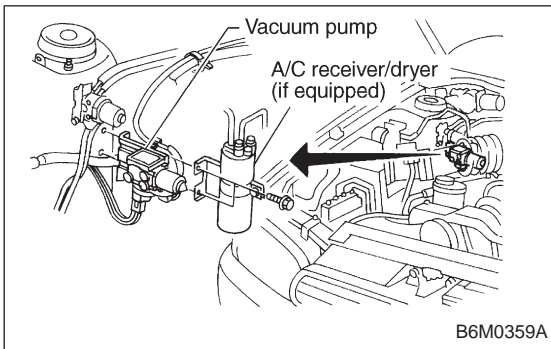

**4. VACUUM PUMP AND VALVES**

- 1) Disconnect connector from vacuum pump.
- 2) Remove bolts which secure vacuum pump.
- 3) Remove A/C receiver/drier bracket.
- 4) Remove vacuum pump while disconnecting vacuum hose.

**Tightening torque:**

**$7.4 \pm 1.5 \text{ N}\cdot\text{m}$  ( $0.75 \pm 0.15 \text{ kg}\cdot\text{m}$ ,  $5.4 \pm 1.1 \text{ ft}\cdot\text{lb}$ )**

**5. STOP AND BRAKE SWITCH**

Refer to 4-5 [C100] (MT) or 4-5 [C200] (AT) as for removal and installation of stop and brake switch.

**6. CLUTCH SWITCH (MT)**

Refer to 4-5 [C100] as for removal and installation of clutch switch.

**7. INHIBITOR SWITCH (AT)**

Refer to 3-2 [W4A3] as for removal and installation of inhibitor switch.

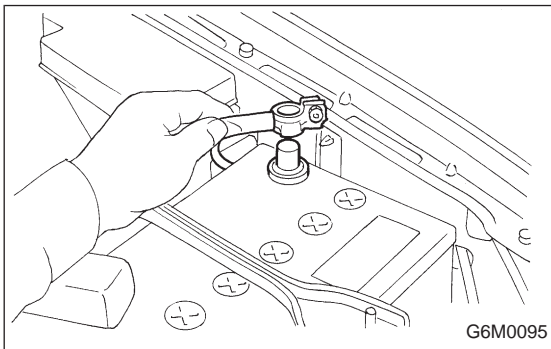

**8. CRUISE CONTROL MODULE**

- 1) Disconnect battery ground cable.

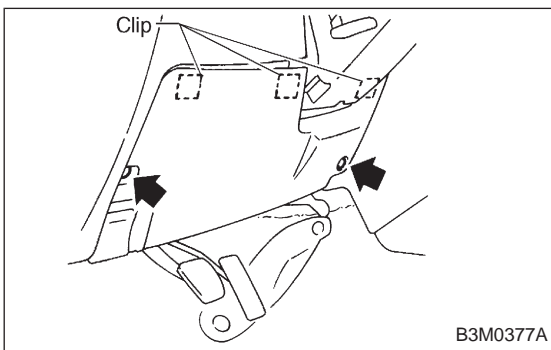

- 2) Remove lower cover and then disconnect connector.

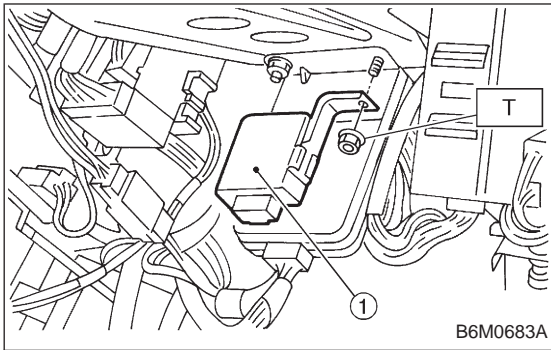

3) Remove door lock timer ① while disconnecting connector.

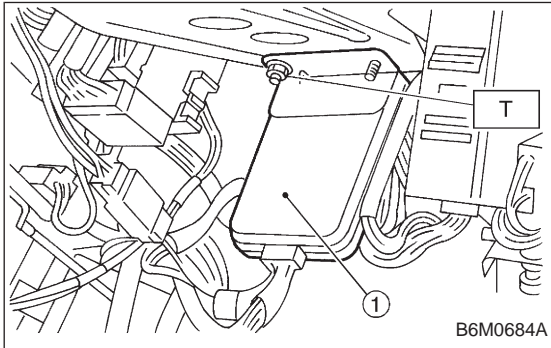

4) Remove cruise control module ① while disconnecting connector.

5) Installation is in the reverse order of removal.

**Tightening torque:**

**$7.4 \pm 2.5 \text{ N}\cdot\text{m}$  ( $0.75 \pm 0.25 \text{ kg}\cdot\text{m}$ ,  $5.4 \pm 1.8 \text{ ft}\cdot\text{lb}$ )**

## C: DRIVING TESTS

Conduct road tests by selecting a smooth, flat road or use free rollers as road test simulation.

### 1. MAIN SWITCH

- 1) Turn ignition switch ON.
- 2) Check that indicator light comes on when main switch is pressed (ON).
- 3) Check that indicator light goes out when main switch is pressed again (OFF).
- 4) Turn ignition switch OFF with main switch ON (which is indicated by illumination.).
- 5) Turn ignition switch ON again to ensure that indicator light remains OFF.

### 2. COMMAND SWITCH

- 1) Check that command switch is properly set in "SET/COAST", "RESUME/ACCEL" or "CANCEL" mode.
- 2) Also check that command switch returns to the original position when released.

### 3. CONSTANT SPEED TEST

- 1) Turn main switch ON.
- 2) Drive vehicle at speed greater than 40 km/h (25 MPH).
- 3) Press command switch to set in "SET/COAST" mode.
- 4) Ensure that vehicle is maintained at the speed set when command switch was pressed.

### 4. ACCELERATION TEST

- 1) Set vehicle speed at speed greater than 40 km/h (25 MPH).

2) Ensure that vehicle continues to accelerate while holding command switch in RESUME/ACCEL mode, and that vehicle maintains that optional speed when command switch is released.

#### **5. DECELERATION TEST**

1) Set vehicle speed at optional speed greater than 40 km/h (25 MPH).

2) Ensure that vehicle continues to decelerate while holding command switch in SET/COAST mode, and that it maintains that optional speed when command switch is released.

#### **NOTE:**

When vehicle speed reaches the lower speed limit of 30 km/h (19 MPH) during deceleration, cruise control will be released.