

4. Intake Manifold

A: REMOVAL

- 1) Release fuel pressure. <Ref. to 2-8 [W1A0].>
- 2) Disconnect connector from mass air flow sensor.
- 3) Remove air intake duct, air cleaner upper cover and air cleaner element.

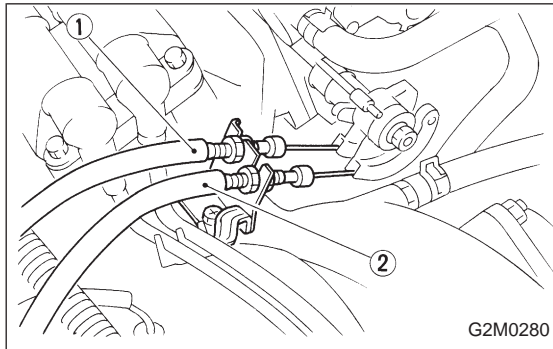

- 4) Disconnect accelerator cable ①.
- 5) Disconnect cruise control cable ②. (With cruise control model)

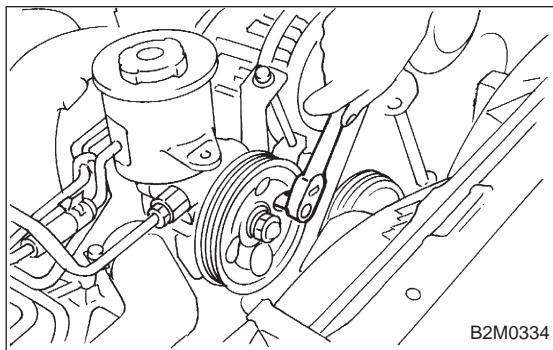

- 6) Disconnect hoses from pressure sources switching solenoid valve.

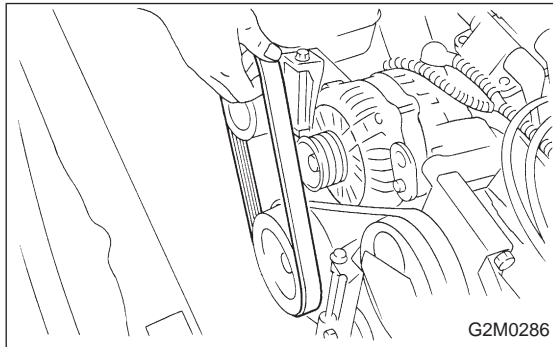

- 7) Remove power steering pump from bracket.
 - (1) Loosen lock bolt and slider bolt, and remove front side V-belt.

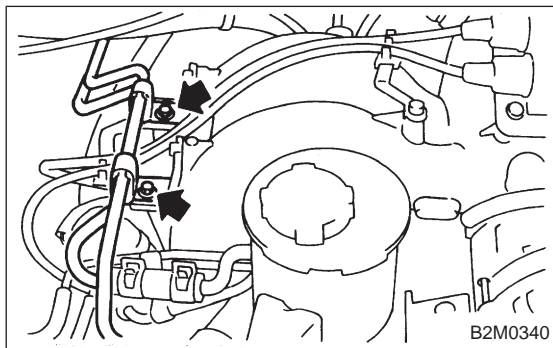

- (2) Remove pipe with bracket from intake manifold.

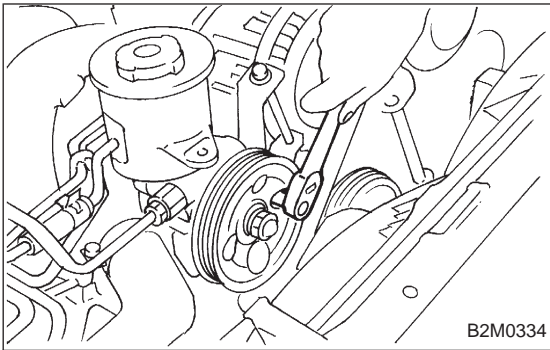

(3) Remove bolts which install power steering pump from bracket.

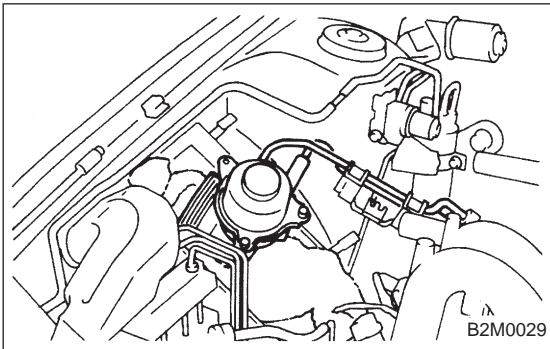

(4) Place power steering pump on the right side wheel apron.

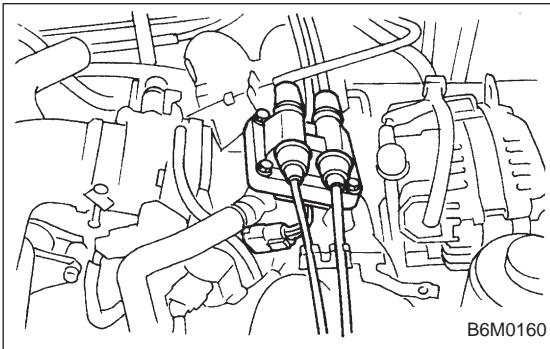

8) Disconnect spark plug cords from ignition coil.

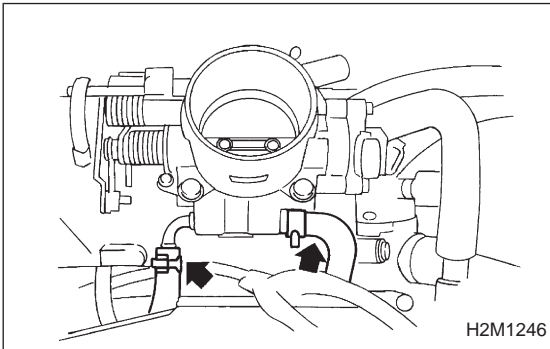

9) Disconnect engine coolant hoses from throttle body.

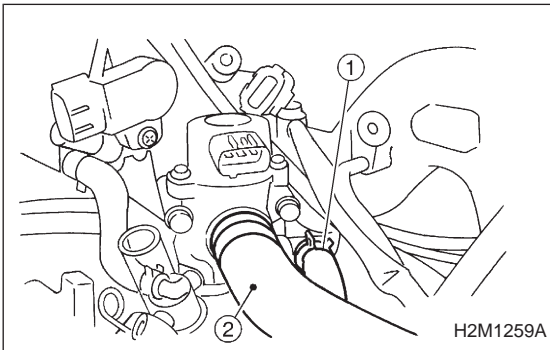

10) Disconnect engine coolant hose ① from idle air control solenoid valve.

11) Disconnect air by-pass hose ② from idle air control solenoid valve.

4. Intake Manifold

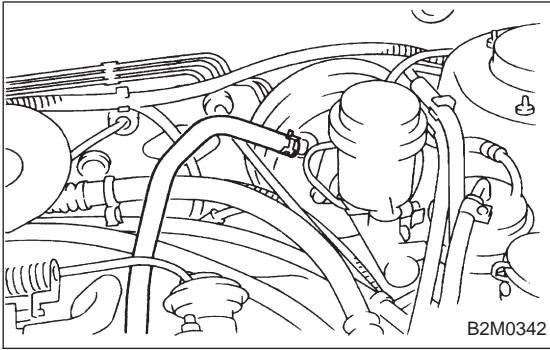

12) Disconnect brake booster hose.

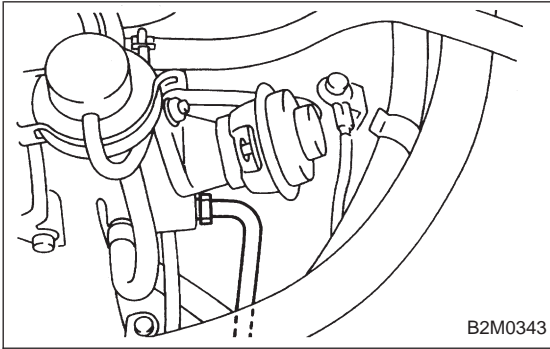

13) Remove EGR pipe.

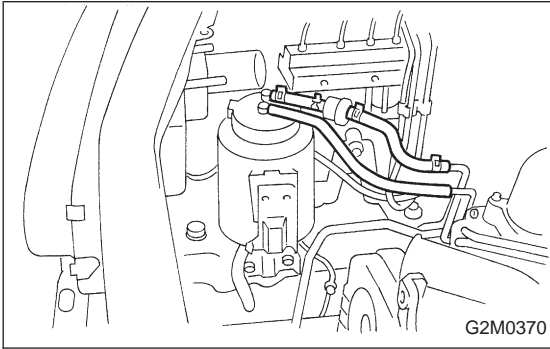

14) Disconnect canister hose from pipe.

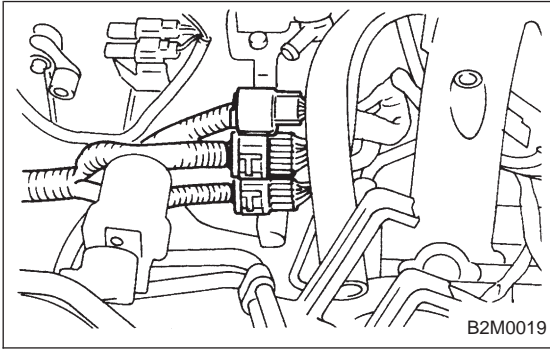

15) Disconnect engine harness connectors from bulkhead harness connectors.

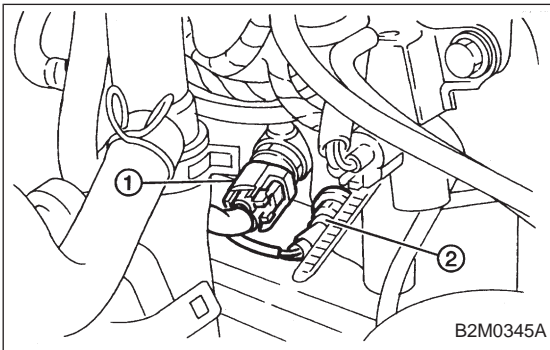

16) Disconnect connectors from engine coolant temperature sensor ① and thermometer ②.

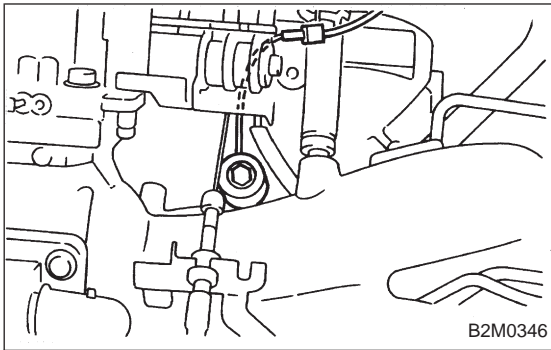

17) Disconnect connector from knock sensor.

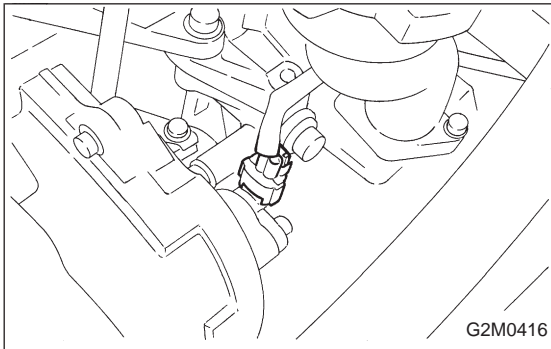

18) Disconnect connector from camshaft position sensor.

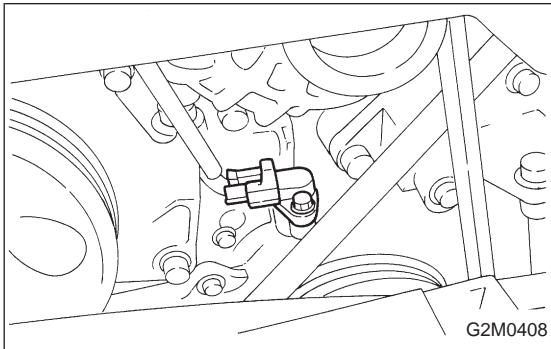

19) Disconnect connector from crankshaft position sensor.

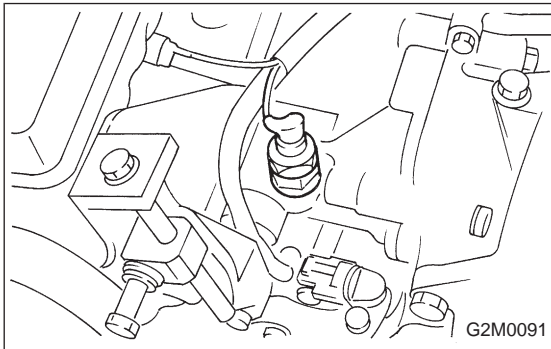

20) Disconnect connector from oil pressure switch.

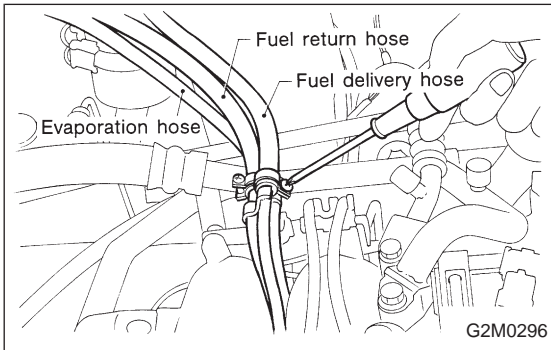

21) Disconnect fuel hoses from pipes.
WARNING:
Catch fuel from hoses in a container.

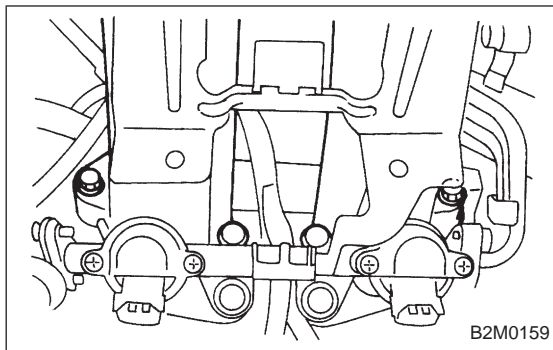

22) Remove bolts which hold intake manifold onto cylinder heads.

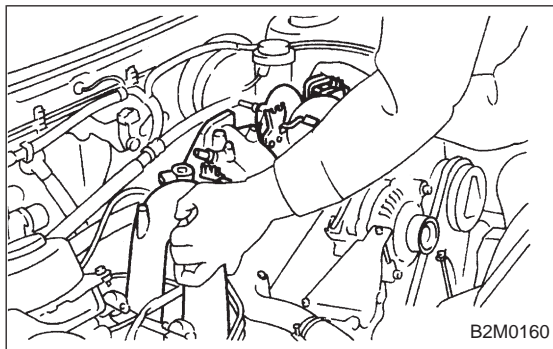

23) Remove intake manifold.

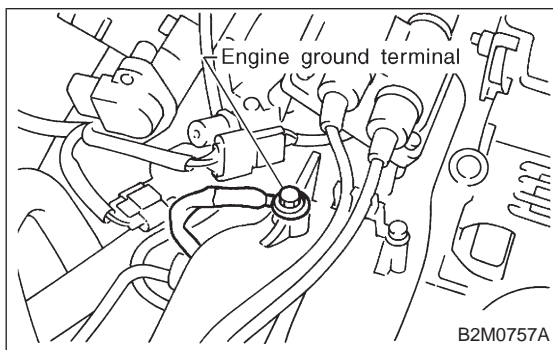

B: DISASSEMBLY

1) Disconnect engine ground terminal from intake manifold.

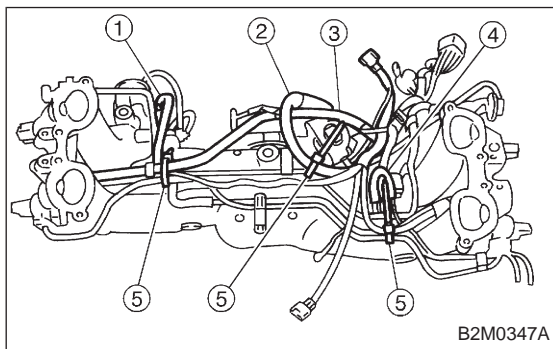

2) Disconnect connectors from throttle position sensor, ignition coil, fuel injectors, idle air control solenoid valve, purge control solenoid valve and EGR solenoid valve.

3) Remove engine harness from intake manifold.

- ① EGR solenoid valve
- ② Throttle position sensor
- ③ Idle air control solenoid valve
- ④ Purge control solenoid valve
- ⑤ Harness band

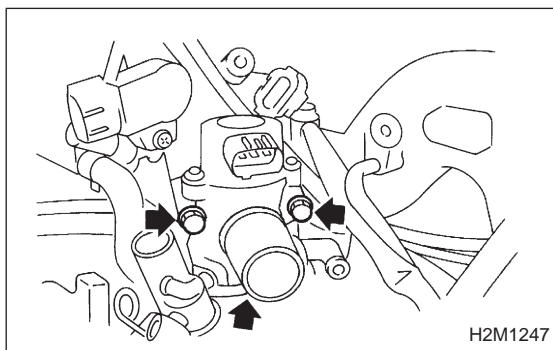

4) Remove idle air control solenoid valve from intake manifold.

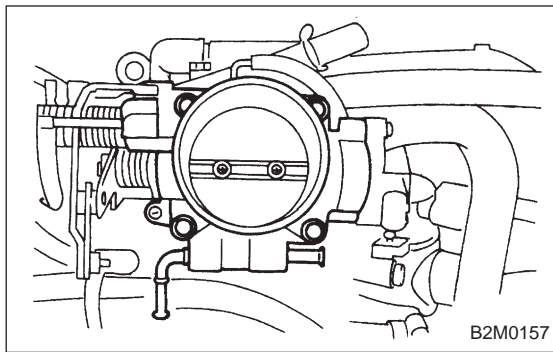

5) Remove throttle body from intake manifold.

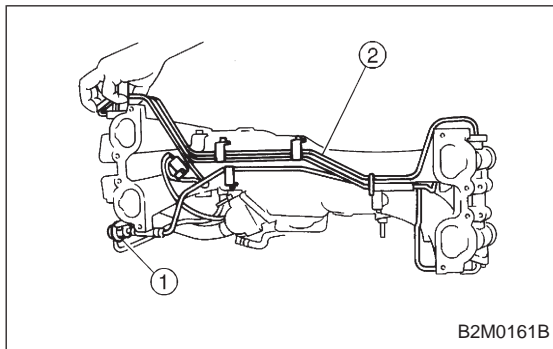

6) Remove fuel pipes, etc. from intake manifold.

① Pressure regulator

② Fuel pipe ASSY

7) Remove EGR solenoid valve and purge control solenoid valve.

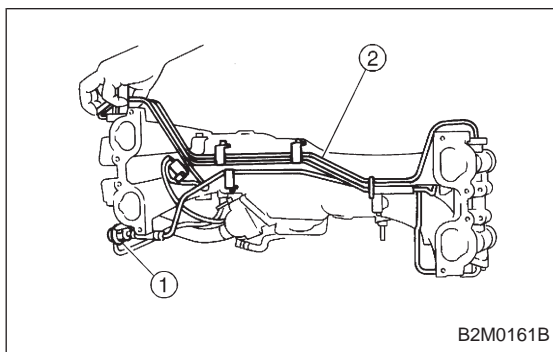

C: ASSEMBLY

1) Install EGR solenoid valve and purge control solenoid valve.

2) Assemble fuel pipes, etc. to intake manifold.

① Pressure regulator

② Fuel pipe ASSY

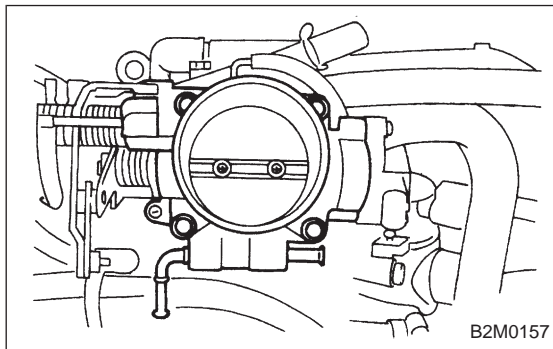

3) Assemble throttle body to intake manifold.

CAUTION:

Replace gasket with a new one.

Tightening torque:

$22 \pm 2 \text{ N}\cdot\text{m}$ ($2.2 \pm 0.2 \text{ kg}\cdot\text{m}$, $15.9 \pm 1.4 \text{ ft}\cdot\text{lb}$)

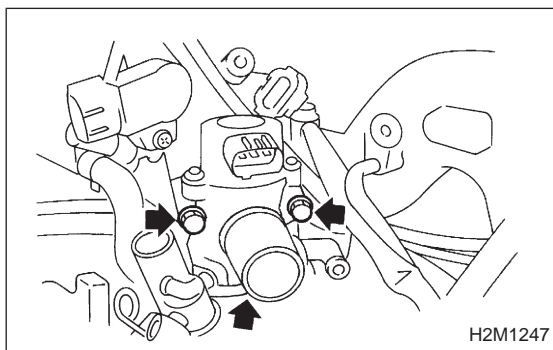

4) Install idle air control solenoid valve to intake manifold.

CAUTION:

Replace gasket with a new one.

Tightening torque:

$6.4 \pm 0.5 \text{ N}\cdot\text{m}$ ($0.65 \pm 0.05 \text{ kg}\cdot\text{m}$, $4.7 \pm 0.4 \text{ ft}\cdot\text{lb}$)

4. Intake Manifold

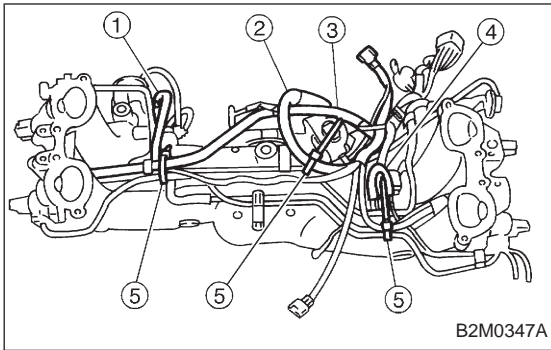

- 5) Install engine harness onto intake manifold.
- 6) Connect connectors to throttle position sensor, ignition coil, fuel injectors, idle air control solenoid valve, purge control solenoid valve and EGR solenoid valve.

- ① EGR solenoid valve
- ② Throttle position sensor
- ③ Idle air control solenoid valve
- ④ Purge control solenoid valve
- ⑤ Harness band

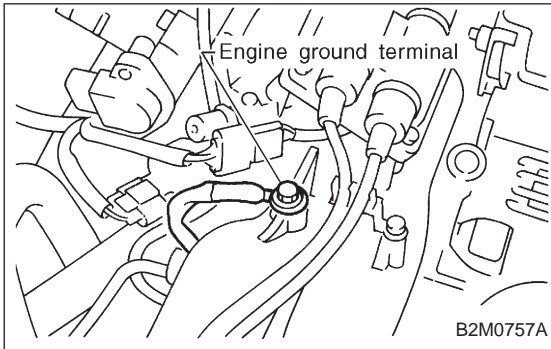

- 7) Connect engine ground terminal to intake manifold.

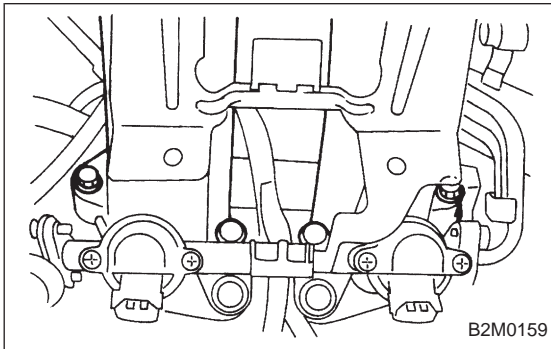
**D: INSTALLATION**

- 1) Install intake manifold onto cylinder heads.

CAUTION:

Always use new gaskets.

Tightening torque:

25 ± 2 N·m (2.5 ± 0.2 kg·m, 18.1 ± 1.4 ft·lb)

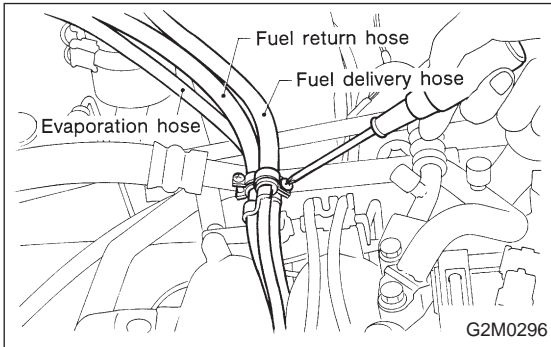

- 2) Connect fuel hoses.

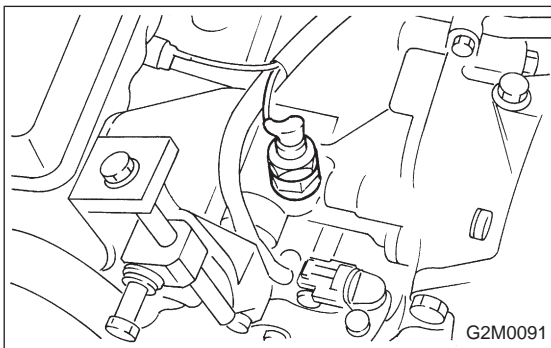

- 3) Connect connector to oil pressure switch.

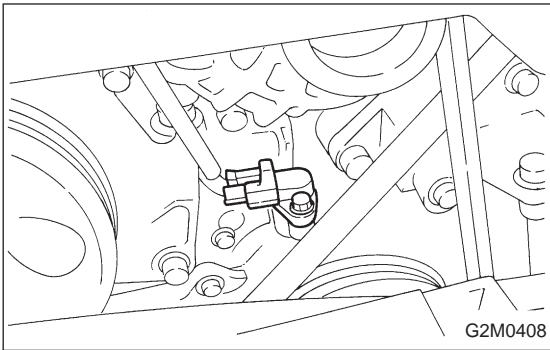

4) Connect connector to crankshaft position sensor.

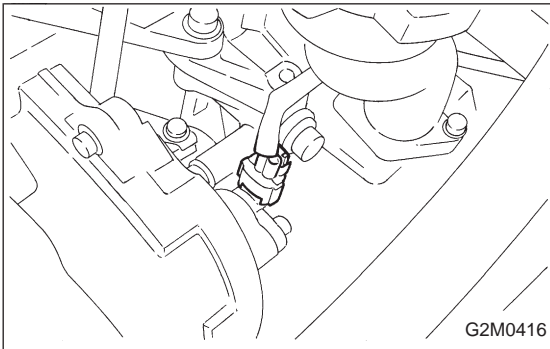

5) Connect connector to camshaft position sensor.

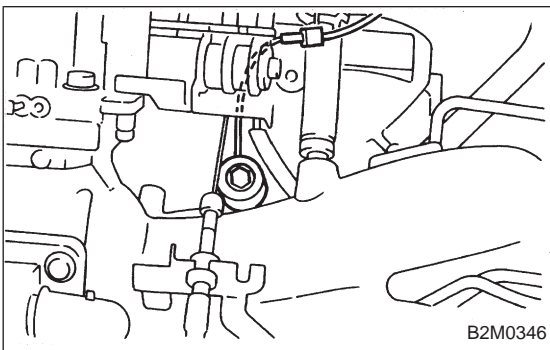

6) Connect connector to knock sensor.

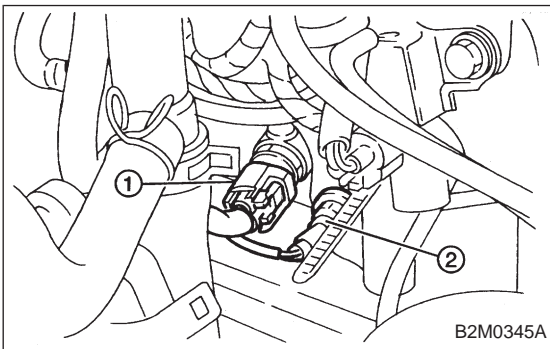

7) Connect connectors to engine coolant temperature sensor ① and thermometer ②.

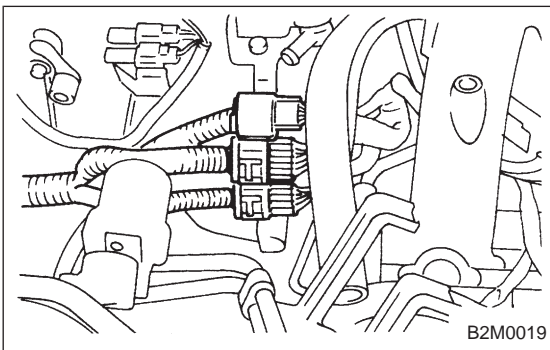

8) Connect engine harness connector to bulkhead harness connectors.

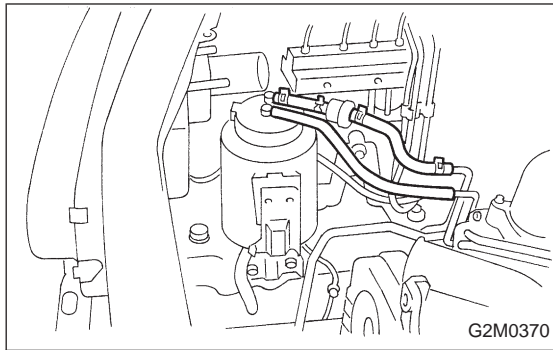

9) Connect canister hoses.

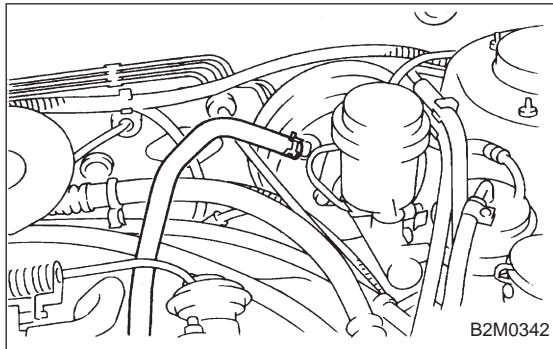

10) Connect brake booster vacuum hose.

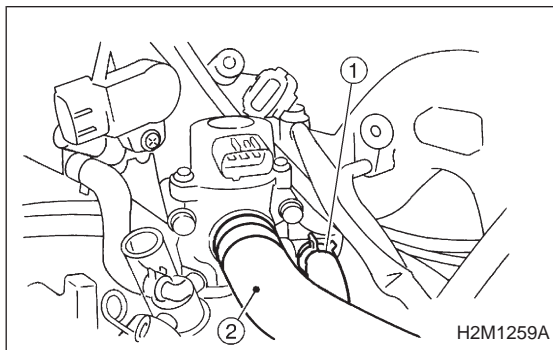

11) Connect engine coolant hose ① to idle air control solenoid valve.

12) Connect air by-pass hose ② to idle air control solenoid valve.

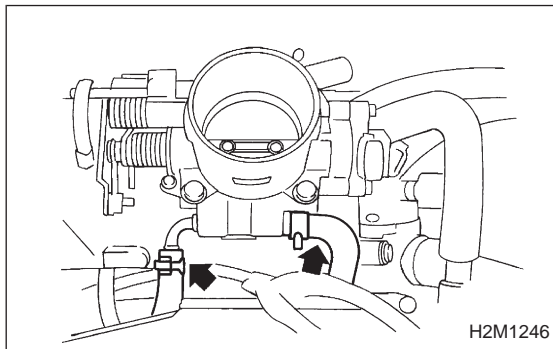

13) Connect engine coolant hoses to throttle body.

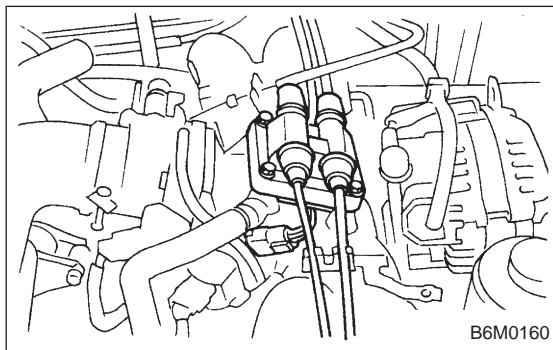

14) Connect spark plug cords to ignition coil.

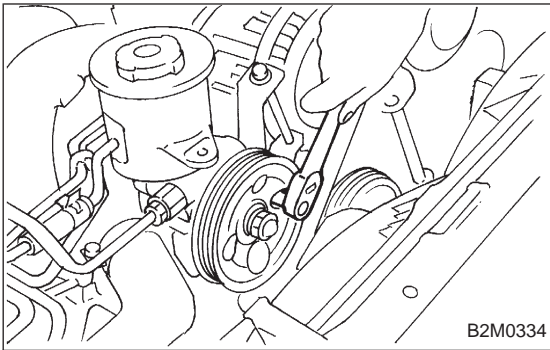

- 15) Install power steering pump on bracket.
 (1) Install power steering pump on bracket, and tighten bolts.

Tightening torque:
 $20.1 \pm 2.5 \text{ N}\cdot\text{m}$ ($2.05 \pm 0.25 \text{ kg}\cdot\text{m}$, $14.8 \pm 1.8 \text{ ft}\cdot\text{lb}$)

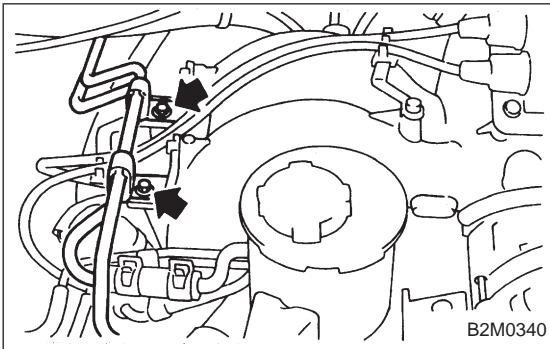

- (2) Install power steering pipe bracket on right side intake manifold.

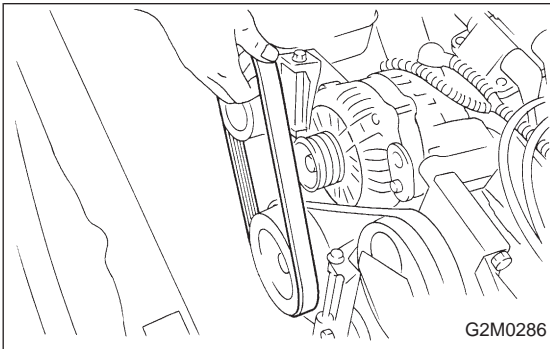

- (3) Install front side V-belt, and adjust it.
 <Ref. to 1-5 [01A0].>

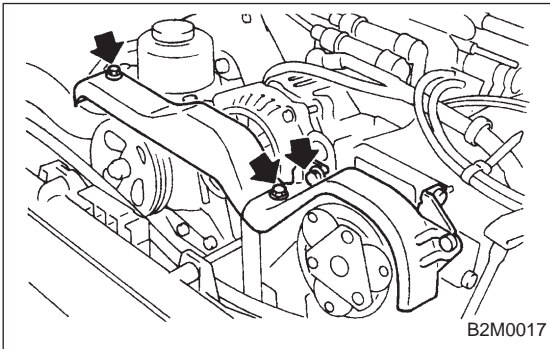

- (4) Install V-belt cover.

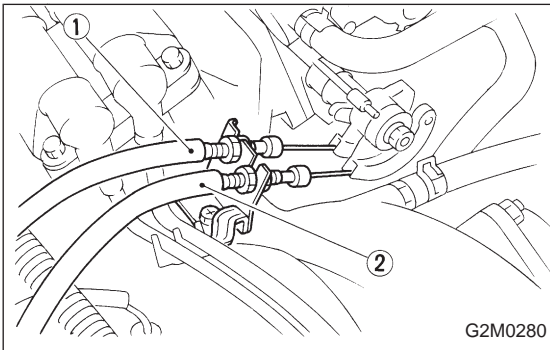

- 16) Connect accelerator cable ①.
 17) Connect cruise control cable ②. (With cruise control model)

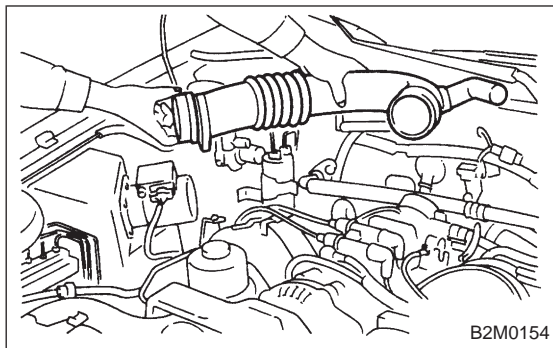

- 18) Install air cleaner element, air cleaner upper cover and air intake duct.
- 19) Connect connector to mass air flow sensor.

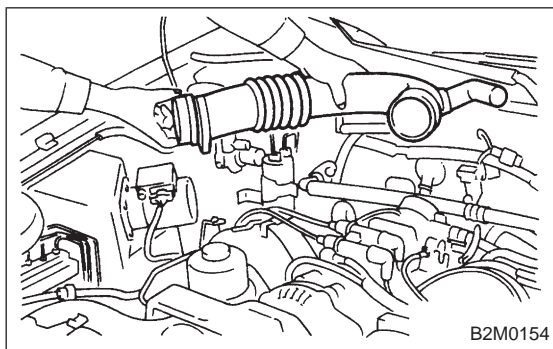

5. Engine Coolant Temperature Sensor

A: REMOVAL AND INSTALLATION

- 1) Remove air intake duct.
- 2) Disconnect connector from engine coolant temperature sensor.
- 3) Remove engine coolant temperature sensor.

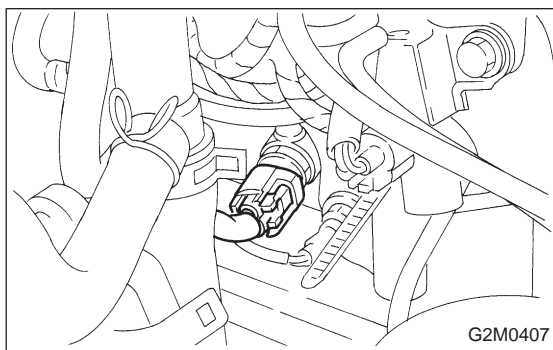

- 4) Installation is in the reverse order of removal.

Tightening torque:

$25 \pm 3 \text{ N}\cdot\text{m}$ ($2.5 \pm 0.3 \text{ kg}\cdot\text{m}$, $18.1 \pm 2.2 \text{ ft}\cdot\text{lb}$)

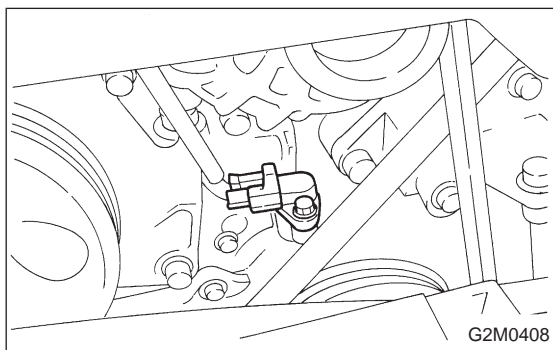
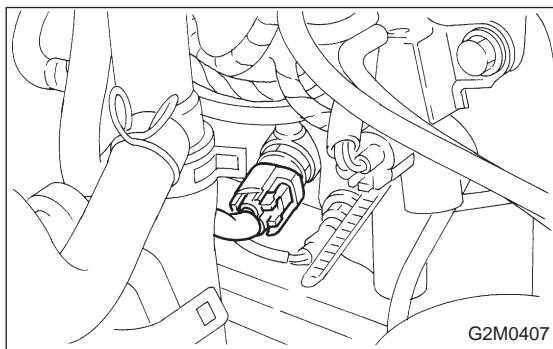

6. Crankshaft Position Sensor

A: REMOVAL AND INSTALLATION

- 1) Remove bolt which install crankshaft position sensor to cylinder block.