

9. Rear Strut
A: REMOVAL

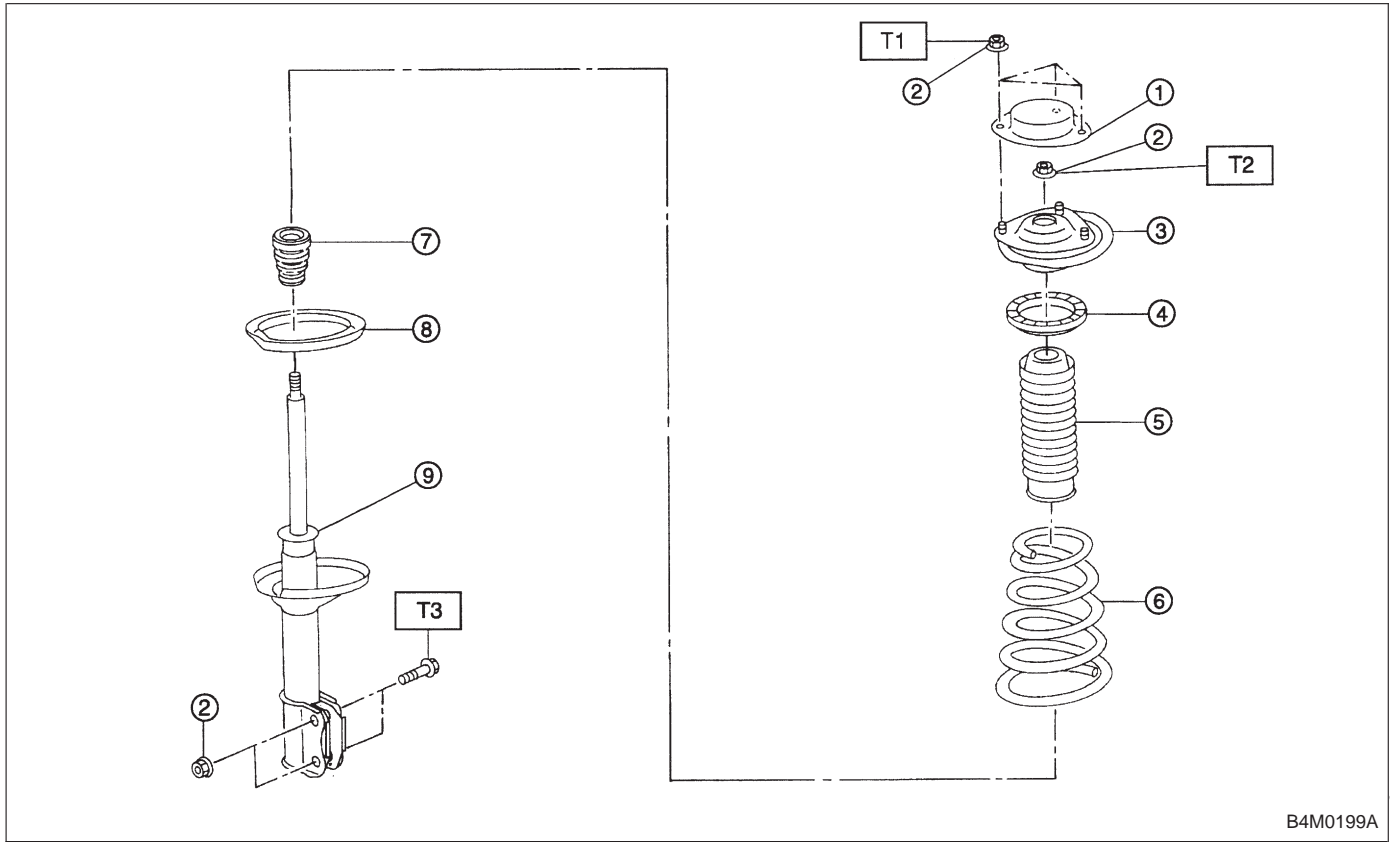

- | | |
|---------------------|---------------------|
| ① Strut mount cap | ⑥ Coil spring |
| ② Self-locking nut | ⑦ Helper |
| ③ Strut mount | ⑧ Rubber seat lower |
| ④ Rubber seat upper | ⑨ Damper strut |
| ⑤ Dust cover | |

Tightening torque: N·m (kg·m, ft·lb)
T1: 20±6 (2.0±0.6, 14.5±4.3)
T2: 59±10 (6.0±1.0, 43±7)
T3: 196⁺³⁹₋₁₀ (20.0^{+4.0}_{-1.0}, 145⁺²⁹₋₇)

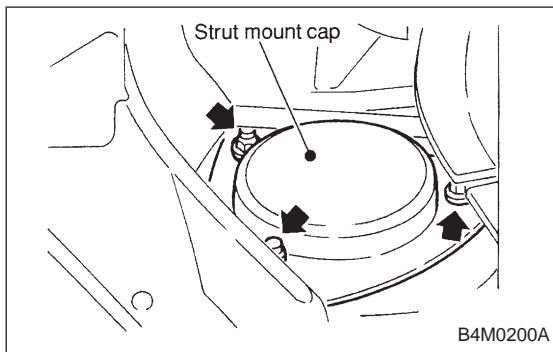

- 1) Depress brake pedal and secure it in that position using a wooden block, etc.
- 2) Remove rear seat cushion and backrest. (Sedan)

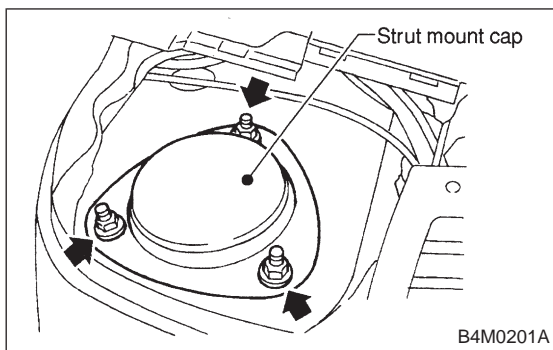

- 3) Remove strut cap of rear quarter trim. (Wagon)
- 4) Loosen rear wheel nuts.
- 5) Jack-up vehicle, support it with safety stands (rigid racks) and remove rear wheels.
- 6) Remove brake hose clip.

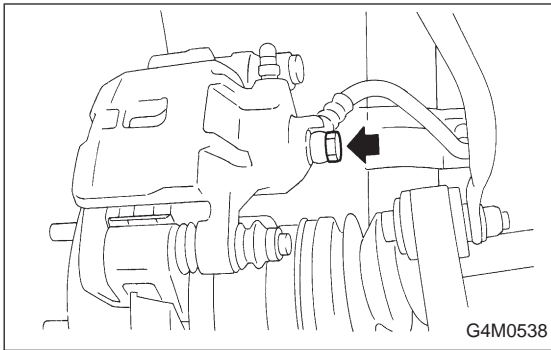

- 7) Models equipped with rear disc brakes:
Remove union bolt from brake caliper.
- 8) Models equipped with rear drum brakes:
Disconnect brake hose from brake pipe from strut, and disconnect brake pipe from drum brake.

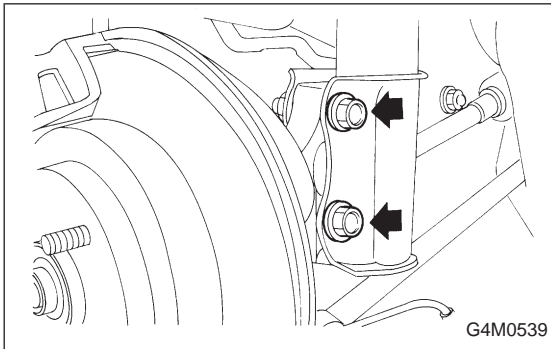

- 9) Remove bolts which secure rear strut to housing.
- 10) Remove nuts securing strut mount to body.
- 11) Remove strut mount cap.

B: DISASSEMBLY

For disassembly of rear strut, refer to procedures outlined under front strut as a guide.

<Ref. to 4-1 [W4B0].>

C: INSPECTION

Refer to Front Strut 4-1 [W4C0] as a guide for inspection procedures.

D: ASSEMBLY

Refer to Front Strut 4-1 [W4D0] as a guide for assembly procedures.

CAUTION:

- Install rear strut with “FWD” or “4WD” mark on strut mount facing outside of vehicle body.
- Insert the protrusion of lower rubber seat into the strut spring seat hole.

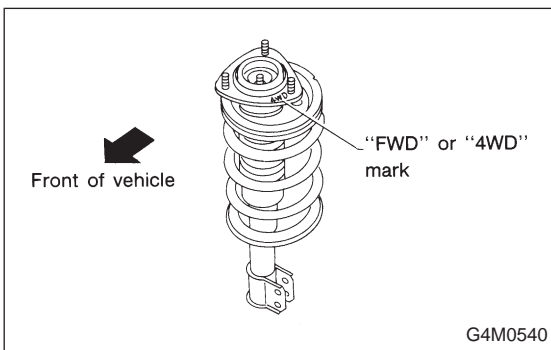

E: INSTALLATION

- 1) Install strut mount cap.
- 2) Tighten self-locking nut used to secure strut mount to vehicle body.

CAUTION:

Use a new self-locking nut.

NOTE:

Tighten strut mount and cap as a unit.

Tightening torque:

$20 \pm 6 \text{ N}\cdot\text{m}$ ($2.0 \pm 0.6 \text{ kg}\cdot\text{m}$, $14.5 \pm 4.3 \text{ ft}\cdot\text{lb}$)

- 3) Tighten bolts securing rear strut to housing.

Tightening torque:

$196_{-10}^{+39} \text{ N}\cdot\text{m}$ ($20.0_{-1.0}^{+4.0} \text{ kg}\cdot\text{m}$, $145_{-7}^{+29} \text{ ft}\cdot\text{lb}$)

CAUTION:

Use a new self-locking nut.

- 4) Models with rear disc brakes:
Tighten brake hose union bolt on brake caliper.

Tightening torque:

$18 \pm 3 \text{ N}\cdot\text{m}$ ($1.8 \pm 0.3 \text{ kg}\cdot\text{m}$, $13.0 \pm 2.2 \text{ ft}\cdot\text{lb}$)

Models with rear drum brakes:
Connect brake hose to brake pipe.

Tightening torque:

$15_{-2}^{+3} \text{ N}\cdot\text{m}$ ($1.5_{-0.2}^{+0.3} \text{ kg}\cdot\text{m}$, $10.8_{-1.4}^{+2.2} \text{ ft}\cdot\text{lb}$)

- 5) Insert brake hose clip between brake hose and lower side of strut.

CAUTION:

- Check that hose clip is positioned properly.
- Check brake hose for twisting, or excessive tension.
- Models equipped with A.B.S.:

Do not subject A.B.S. sensor harness to excessive tension.

- 6) Be sure to bleed air from brake system.
- 7) Lower vehicle and tighten wheel nut.

Tightening torque:

$88 \pm 10 \text{ N}\cdot\text{m}$ ($9 \pm 1 \text{ kg}\cdot\text{m}$, $65 \pm 7 \text{ ft}\cdot\text{lb}$)

- 8) Sedan:
Install rear seat backrest and rear seat cushion.

Wagon:

Install strut cap of rear quarter trim.

NOTE:

Check wheel alignment and adjust if necessary.