

### 7. Diagnostics Chart for ABS Warning Light Circuit and Diagnosis Circuit Failure

**A: ABS WARNING LIGHT DOES NOT COME ON.**

**DIAGNOSIS:**

- ABS warning light circuit is open or shorted.

**TROUBLE SYMPTOM:**

- When ignition switch is turned ON (engine OFF), ABS warning light does not come on.

**WIRING DIAGRAM:**

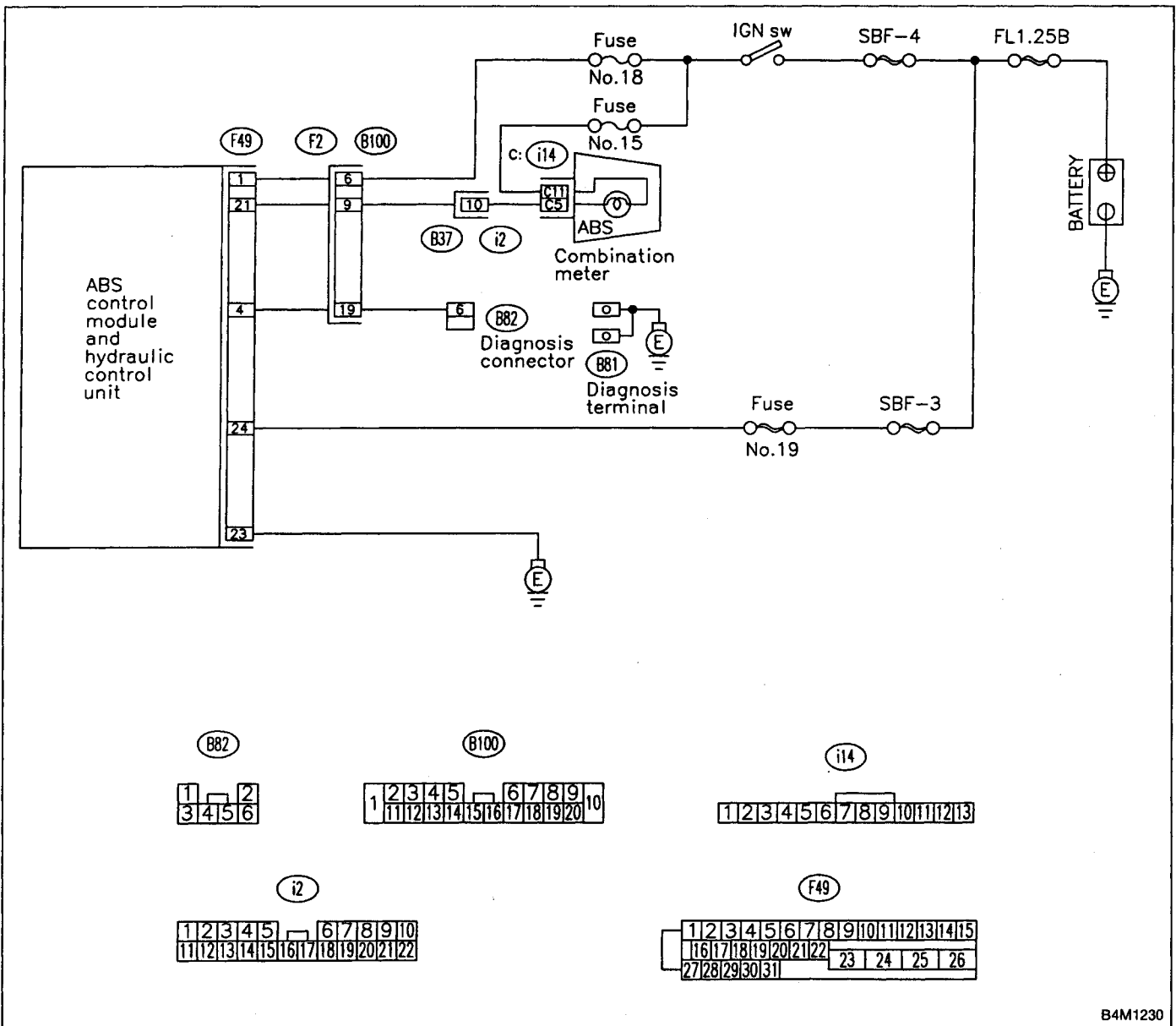

<b>7A1</b>	<b>CHECK IF OTHER WARNING LIGHTS TURN ON.</b>
------------	---

Turn ignition switch to ON (engine OFF).

- CHECK** : **Do other warning lights turn on?**
- YES** : Go to step **7A2**.
- NO** : Repair combination meter.

<b>7A2</b>	<b>CHECK ABS WARNING LIGHT BULB.</b>
------------	--------------------------------------

- 1) Turn ignition switch to OFF.
- 2) Remove combination meter.
- 3) Remove ABS warning light bulb from combination meter.

- CHECK** : **Is ABS warning light bulb OK?**
- YES** : Go to step **7A3**.
- NO** : Replace ABS warning light bulb.

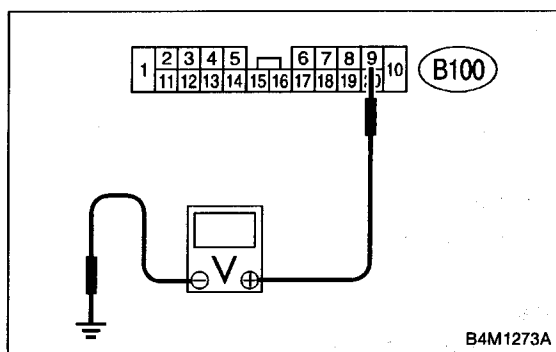

<b>7A3</b>	<b>CHECK BATTERY SHORT OF ABS WARNING LIGHT HARNESS.</b>
------------	--

- 1) Disconnect connector (B100) from connector (F2).
- 2) Measure voltage between connector (B100) and chassis ground.

**Connector & terminal**  
**(B100) No. 9 (+) — Chassis ground (-):**

- CHECK** : **Is the voltage less than 3 V?**
- YES** : Go to step **7A4**.
- NO** : Repair warning light harness.

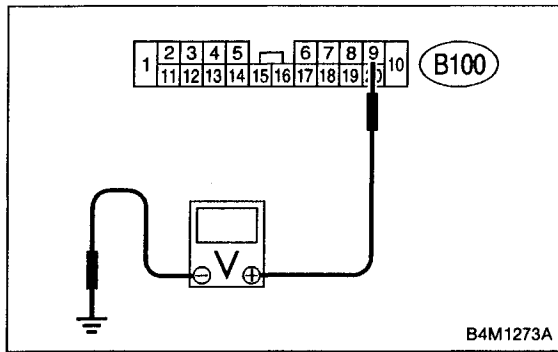

**7A4**

**CHECK BATTERY SHORT OF ABS WARNING LIGHT HARNESS.**

- 1) Turn ignition switch to ON.
- 2) Measure voltage between connector (B100) and chassis ground.

**Connector & terminal**

**(B100) No. 9 (+) — Chassis ground (-):**

**CHECK** : Is voltage less than 3 V?

**YES** : Go to step **7A5**.

**NO** : Repair warning light harness.

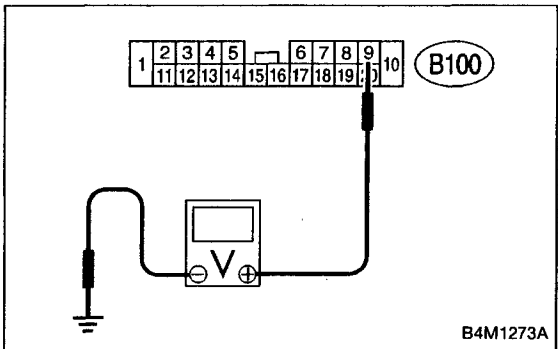

**7A5**

**CHECK WIRING HARNESS.**

- 1) Turn ignition switch to OFF.
- 2) Install ABS warning light bulb from combination meter.
- 3) Install combination meter.
- 4) Turn ignition switch to ON.
- 5) Measure voltage between connector (B100) and chassis ground.

**Connector & terminal**

**(B100) No. 9 (+) — Chassis ground (-):**

**CHECK** : Is voltage between 10 V and 15 V?

**YES** : Go to step **7A6**.

**NO** : Repair wiring harness.

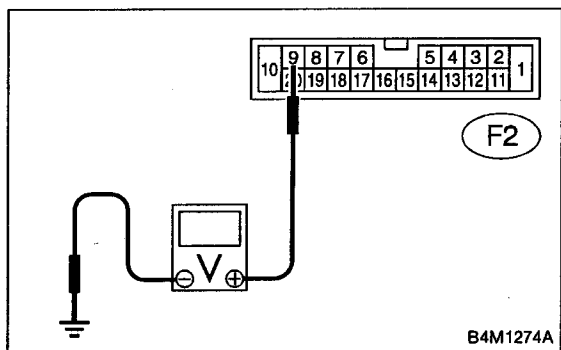

**7A6**

**CHECK BATTERY SHORT OF ABS WARNING LIGHT HARNESS.**

- 1) Turn ignition switch to OFF.
- 2) Measure voltage between connector (F2) and chassis ground.

**Connector & terminal**

**(F2) No. 9 (+) — Chassis ground (-):**

**CHECK** : Is the voltage less than 3 V?

**YES** : Go to step **7A7**.

**NO** : Repair wiring harness.

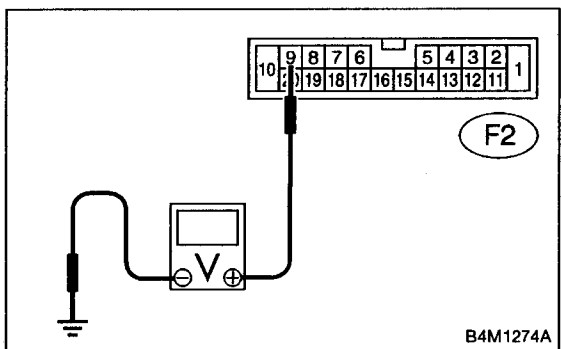

**7A7**

**CHECK BATTERY SHORT OF ABS WARNING LIGHT HARNESS.**

- 1) Turn ignition switch to ON.
- 2) Measure voltage between connector (F2) and chassis ground.

**Connector & terminal**

**(F2) No. 9 (+) — Chassis ground (-):**

**CHECK** : Is voltage less than 3 V?

**YES** : Go to step **7A8**.

**NO** : Repair wiring harness.

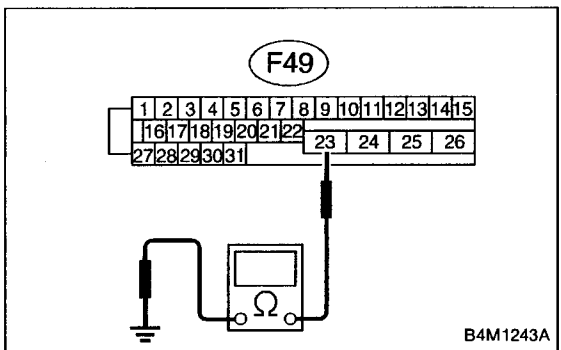

**7A8**

**CHECK GROUND CIRCUIT OF ABSCM&H/U.**

Measure resistance between ABSCM&H/U and chassis ground.

**Connector & terminal**

**(F49) No. 23 — GND:**

**CHECK** : Is the resistance less than 0.5 Ω?

**YES** : Go to step **7A9**.

**NO** : Repair ABSCM&H/U ground harness.

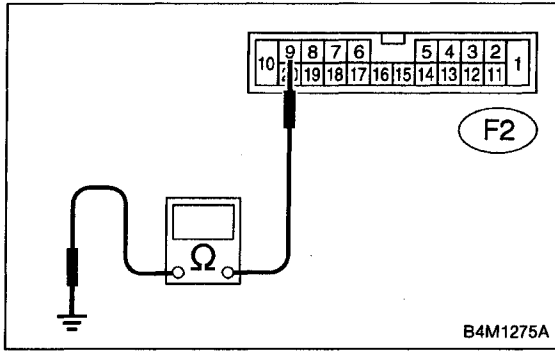

**7A9 CHECK WIRING HARNESS.**

Measure resistance between connector (F2) and chassis ground.

**Connector & terminal (F2) No. 9 — Chassis ground:**

- CHECK** : Is the resistance less than 0.5 Ω?
- YES** : Go to step **7A10**.
- NO** : Repair harness/connector.

**7A10 CHECK POOR CONTACT IN CONNECTORS.**

Turn ignition switch to OFF.

- CHECK** : Is there poor contact in connectors between combination meter and ABSCM&HIU? < Ref. to FOREWORD [T3C1].☆10 >
- YES** : Repair connector.
- NO** : Replace ABSCM&H/U.



<b>7B1</b>	<b>CHECK INSTALLATION OF ABSCM&amp;H/U CONNECTOR.</b>
------------	---

Turn ignition switch to OFF.

**CHECK** : *Is ABSCM&H/U connector inserted into ABSCM until the clamp locks onto it?*

**YES** : Go to step **7B2**.

**NO** : Insert ABSCM&H/U connector into ABSCM&H/U until the clamp locks onto it.

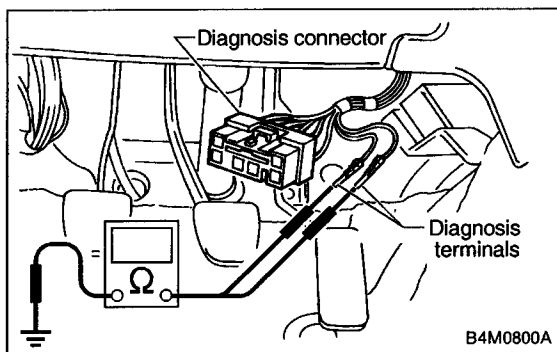

<b>7B2</b>	<b>CHECK DIAGNOSIS TERMINAL.</b>
------------	----------------------------------

Measure resistance between diagnosis terminals (B81) and chassis ground.

**CHECK** : *Terminals*  
**Diagnosis terminal (A) — Chassis ground:**  
**Diagnosis terminal (B) — Chassis ground:**  
*Is the resistance less than 0.5 Ω?*

**YES** : Go to step **7B3**.

**NO** : Repair diagnosis terminal harness.

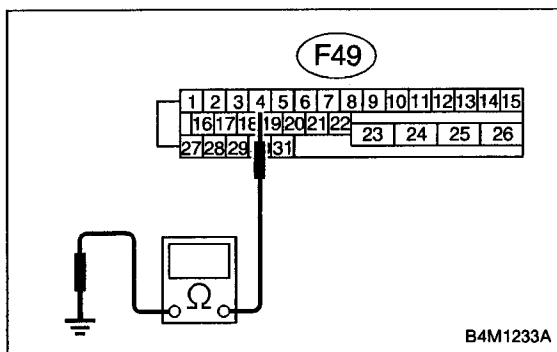

<b>7B3</b>	<b>CHECK DIAGNOSIS LINE.</b>
------------	------------------------------

- 1) Turn ignition switch to OFF.
- 2) Connect diagnosis terminal to diagnosis connector (B82) No. 6.
- 3) Disconnect connector from ABSCM&H/U.
- 4) Measure resistance between ABSCM&H/U connector and chassis ground.

**CHECK** : *Connector & terminal*  
**(F49) No. 4 — Chassis ground:**  
*Is the resistance less than 0.5 Ω?*

**YES** : Go to step **7B4**.

**NO** : Repair harness connector between ABSCM&H/U and diagnosis connector.

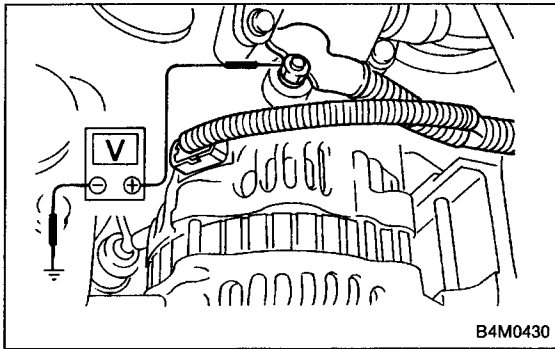

**7B4 CHECK GENERATOR.**

- 1) Start the engine.
- 2) Idle the engine.
- 3) Measure voltage between generator and chassis ground.

**Terminal**

**Generator B terminal (+) — Chassis ground (-):**

**CHECK** : Is the voltage between 10 and 15 V?

**YES** : Go to step 7B5.

**NO** : Repair generator.

**7B5 CHECK BATTERY TERMINAL.**

Turn ignition switch to OFF.

**CHECK** : Is there poor contact at battery terminal?

**YES** : Repair battery terminal.

**NO** : Go to step 7B6.

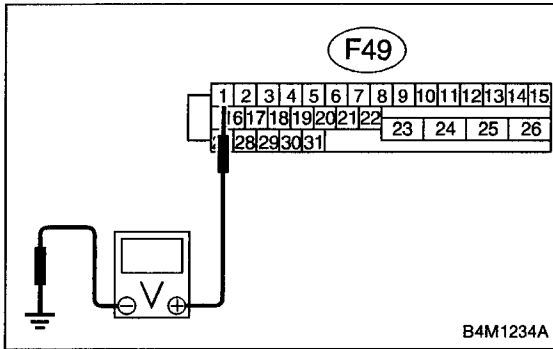

**7B6 CHECK POWER SUPPLY OF ABSCM.**

- 1) Disconnect connector from ABSCM&H/U.
- 2) Start engine.
- 3) Idle the engine.
- 4) Measure voltage between ABSCM&H/U connector and chassis ground.

**Connector & terminal**

**(F49) No. 1 (+) — Chassis ground (-):**

**CHECK** : Is the voltage between 10 and 15 V?

**YES** : Go to step 7B7.

**NO** : Repair ABSCM&H/U power supply circuit.

**7B7 CHECK WIRING HARNESS.**

- 1) Disconnect connector (F2) from connector (B100).
- 2) Turn ignition switch to ON.

**CHECK** : Does the ABS warning light remain off?

**YES** : Go to step 7B8.

**NO** : Repair front wiring harness.



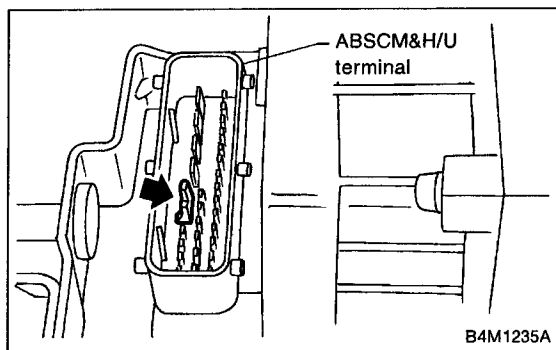

**7B8 CHECK PROJECTION AT ABSCM&H/U.**

- 1) Turn ignition switch to OFF.
- 2) Check for broken projection at the ABSCM&H/U terminal.

**CHECK** : Are the projection broken?

**YES** : Go to step 7B9.

**NO** : Replace ABSCM&H/U.

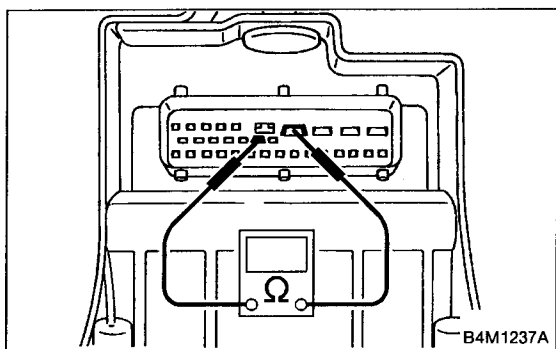

**7B9 CHECK ABSCM&H/U.**

Measure resistance between ABSCM&H/U terminals.

**Terminals**

**No. 21 — No. 23:**

**CHECK** : Is the resistance more than 1 MΩ?

**YES** : Go to step 7B10.

**NO** : Replace ABSCM&H/U.

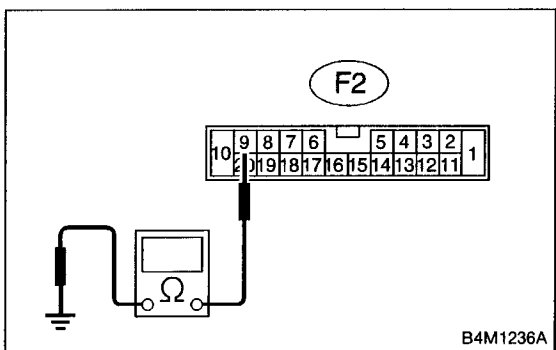

**7B10 CHECK WIRING HARNESS.**

Measure resistance between connector (F2) and chassis ground.

**Connector & terminal**

**(F2) No. 9 — Chassis ground:**

**CHECK** : Is the resistance less than 0.5 Ω?

**YES** : Go to step 7B11.

**NO** : Repair harness.

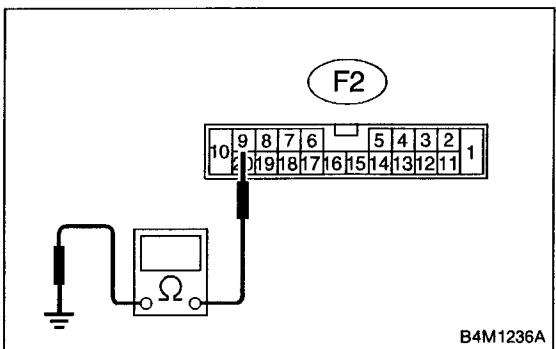

**7B11 CHECK WIRING HARNESS.**

- 1) Connect connector to ABSCM&H/U.
- 2) Measure resistance between connector (F2) and chassis ground.

**Connector & terminal**

**(F2) No. 9 — Chassis ground:**

**CHECK** : Is the resistance more than 1 MΩ?

**YES** : Go to step 7B12.

**NO** : Repair harness.

**7B12 CHECK POOR CONTACT IN ABSCM&H/U CONNECTOR.**

**CHECK** : Is there poor contact in ABSCM&H/U connector? <Ref. to FOREWORD [T3C1].☆10>

**YES** : Repair connector.

**NO** : Replace ABSCM&H/U.

**C: TROUBLE CODE DOES NOT APPEAR.**

**DIAGNOSIS:**

- Diagnosis circuit is open.

**TROUBLE SYMPTOM:**

- The ABS warning light turns on or off normally but the start code cannot be read out in the diagnostic mode.

**WIRING DIAGRAM:**

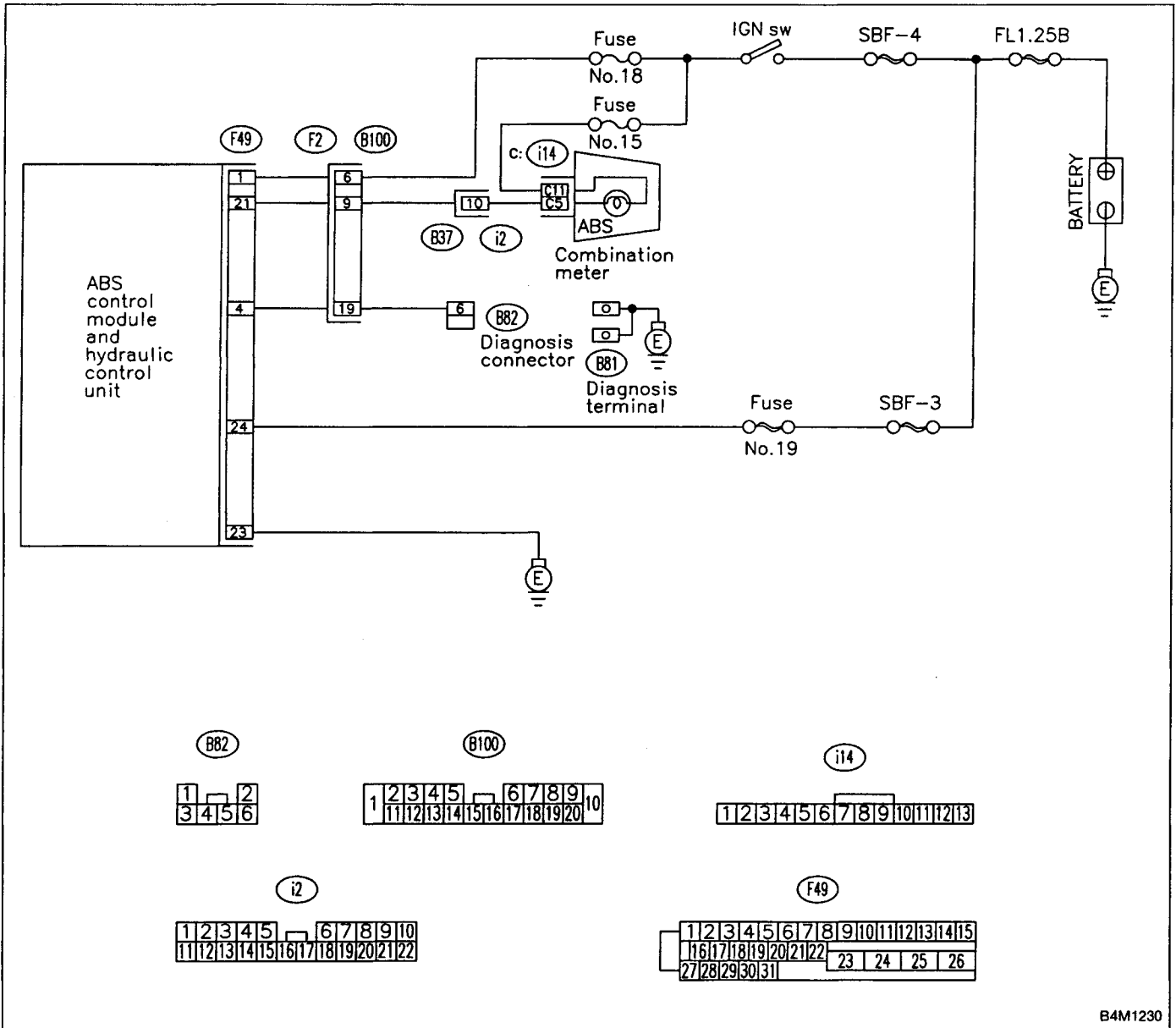

B4M1230

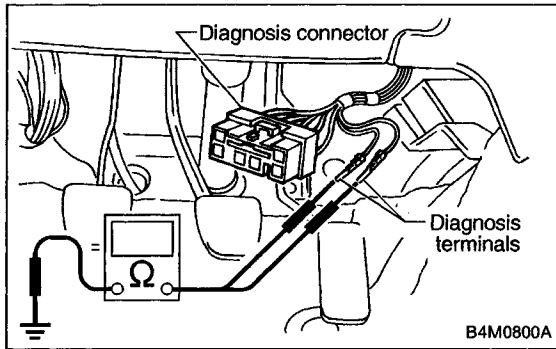

<b>7C1</b>	<b>CHECK DIAGNOSIS TERMINAL.</b>
------------	----------------------------------

Measure resistance between diagnosis terminals (B81) and chassis ground.

**Terminals**

**Diagnosis terminal (A) — Chassis ground:**

**Diagnosis terminal (B) — Chassis ground:**

**CHECK** : Is the resistance less than 0.5 Ω?

**YES** : Go to step 7C2.

**NO** : Repair diagnosis terminal harness.

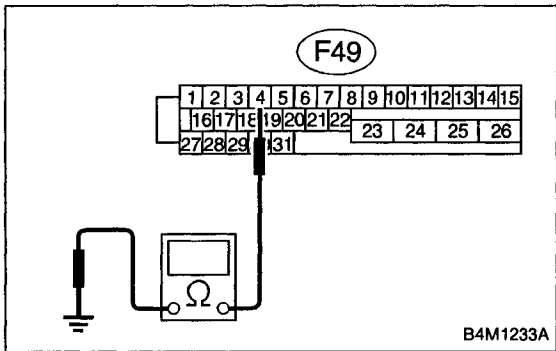

<b>7C2</b>	<b>CHECK DIAGNOSIS LINE.</b>
------------	------------------------------

- 1) Turn ignition switch to OFF.
- 2) Connect diagnosis terminal to diagnosis connector (B82) No. 6.
- 3) Disconnect connector from ABSCM&H/U.
- 4) Measure resistance between ABSCM&H/U connector and chassis ground.

**Connector & terminal**

**(F49) No. 4 — Chassis ground:**

**CHECK** : Is the resistance less than 0.5 Ω?

**YES** : Go to step 7C3.

**NO** : Repair harness connector between ABSCM&H/U and diagnosis connector.

<b>7C3</b>	<b>CHECK POOR CONTACT IN ABSCM&amp;H/U CONNECTOR.</b>
------------	---

**CHECK** : Is there poor contact in ABSCM&H/U connector? <Ref. to FOREWORD [T3C1].☆10 >

**YES** : Repair connector.

**NO** : Replace ABSCM&H/U.