

# 10. Diagnostics Chart with Select Monitor

## A: BASIC DIAGNOSTIC CHART

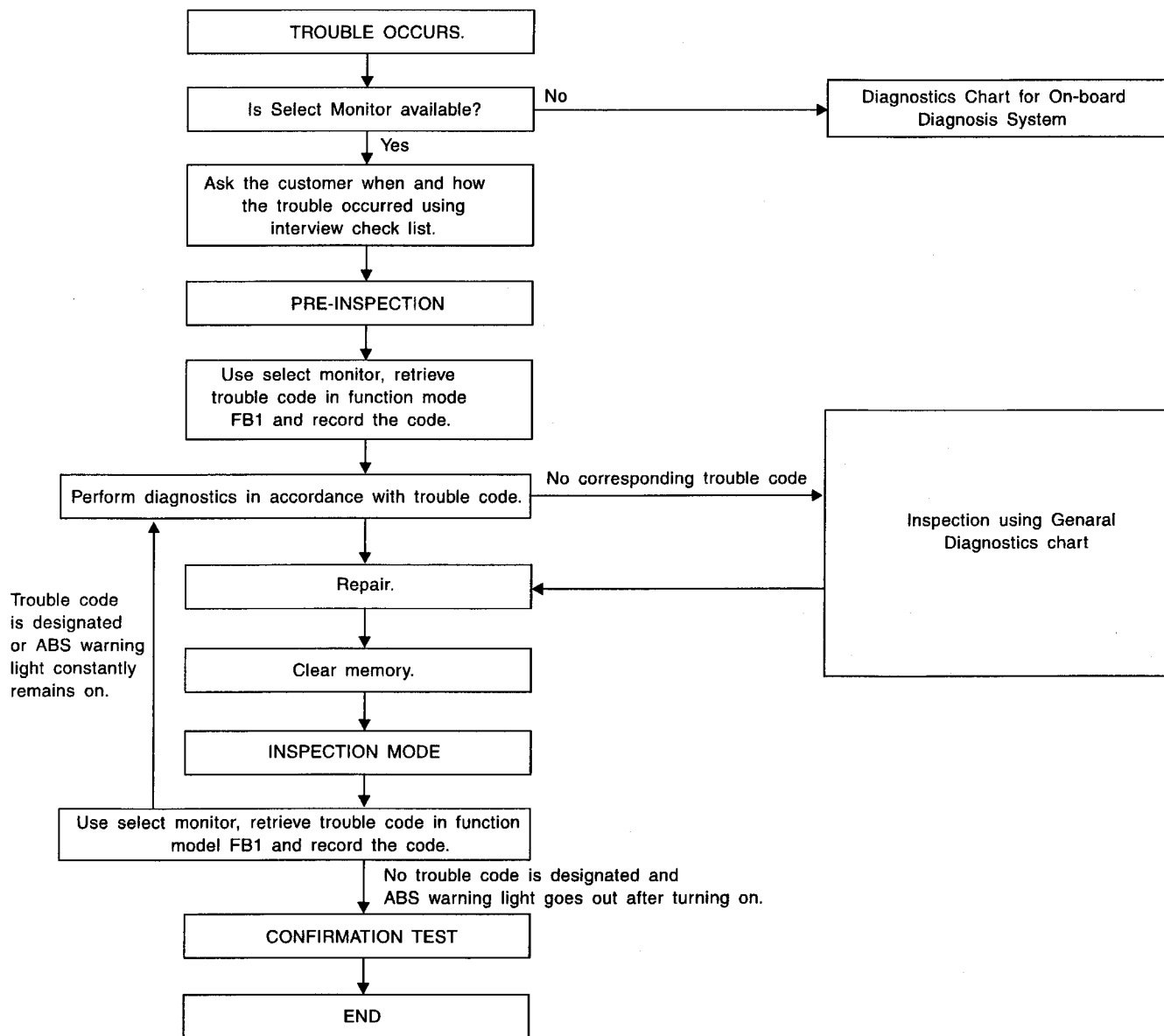

B4M1076A

**CAUTION:**

**Remove foreign matter (dust, water, etc.) from the ABSCM&H/U connector during removal and installation.**

**NOTE:**

To check harness for broken wires or short circuits, shake it while holding it or the connector.

**B: LIST OF TROUBLE CODE**

Code	Display screen (FB1)	Contents of diagnosis	Ref. to
—	ERROR 3 (1)	Select monitor communication failure	[T10C0]☆10
11	NO TROUBLE	Although no trouble appears on the select monitor display, the ABS warning light remains on.	[T10D0]☆10
21	FR. SS HARD	Open circuit or input voltage too high of FR sensor	[T10E0]☆10
22	FR. SS SOFT	Abnormal ABS sensor signal of FR sensor	[T10I0]☆10
23	FL. SS HARD	Open circuit or input voltage too high of FL sensor	[T10F0]☆10
24	FL. SS SOFT	Abnormal ABS sensor signal of FL sensor	[T10J0]☆10
25	RR. SS HARD	Open circuit or input voltage too high of RR sensor	[T10G0]☆10
26	RR. SS SOFT	Abnormal ABS sensor signal of RR sensor	[T10K0]☆10
27	RL. SS HARD	Open circuit or input voltage too high of RL sensor	[T10H0]☆10
28	RL. SS SOFT	Abnormal ABS sensor signal of RL sensor	[T10L0]☆10
29	EITHER. SS SOFT	Abnormal ABS sensor signal (any one of four)	[T10M0]☆10
31	FR. EV VALVE	Abnormal FR inlet valve	[T10N0]☆10
32	FR. AV VALVE	Abnormal FR outlet valve	[T10R0]☆10
33	FL. EV VALVE	Abnormal FL inlet valve	[T10O0]☆10
34	FL. AV VALVE	Abnormal FL outlet valve	[T10S0]☆10
35	RR. EV VALVE	Abnormal RR inlet valve	[T10P0]☆10
36	RR. AV VALVE	Abnormal RR outlet valve	[T10T0]☆10
37	RL. EV VALVE	Abnormal RL inlet valve	[T10Q0]☆10
38	RL. AV VALVE	Abnormal RL outlet valve	[T10U0]☆10
41	ECU	Abnormal ABSCM&H/U	[T10V0]☆10
42	LOW VOLTAGE	Source voltage is low.	[T10W0]☆10
	HIGH VOLTAGE	Source voltage is high.	[T10X0]☆10
44	CCM LINE	A combination of AT control abnormalities (ABS not in control)	[T10Y0]☆10
	CCM OPEN	A combination of AT control abnormalities (ABS in control)	[T10Z0]☆10
51	V. RELAY	Abnormal valve relay	[T10AA0]☆10
	V. RELAY ON	Valve relay ON failure	[T10AB0]☆10
52	M. RELAY OPEN	Open circuit of motor relay	[T10AC0]☆10
	M. RELAY ON	Motor relay ON failure	[T10AD0]☆10
	MOTOR	Abnormal motor	[T10AE0]☆10
54	BLS	Abnormal stop light switch	[T10AF0]☆10
56	G SENSOR LINE	Open or short circuit of G sensor	[T10AG0]☆10
	G SENSOR +B	Battery short of G sensor	[T10AH0]☆10
	G SENSOR H $\mu$	Abnormal G sensor high $\mu$ output	[T10AI0]☆10
	G SENSOR STICK	G sensor output is stuck.	[T10AJ0]☆10

## NOTE:

High  $\mu$  means high friction coefficient against road surface.

\*\*\*\*\*  
**ERROR 3**  
 B4M0943

**C: ERROR 3 (1)**  
**— SELECT MONITOR COMMUNICATION FAILURE —**

**DIAGNOSIS:**

- Faulty harness connector

**TROUBLE SYMPTOM:**

- ABS warning light remains on.
- ERROR 3 or 1 appears on the select monitor display.

**WIRING DIAGRAM:**

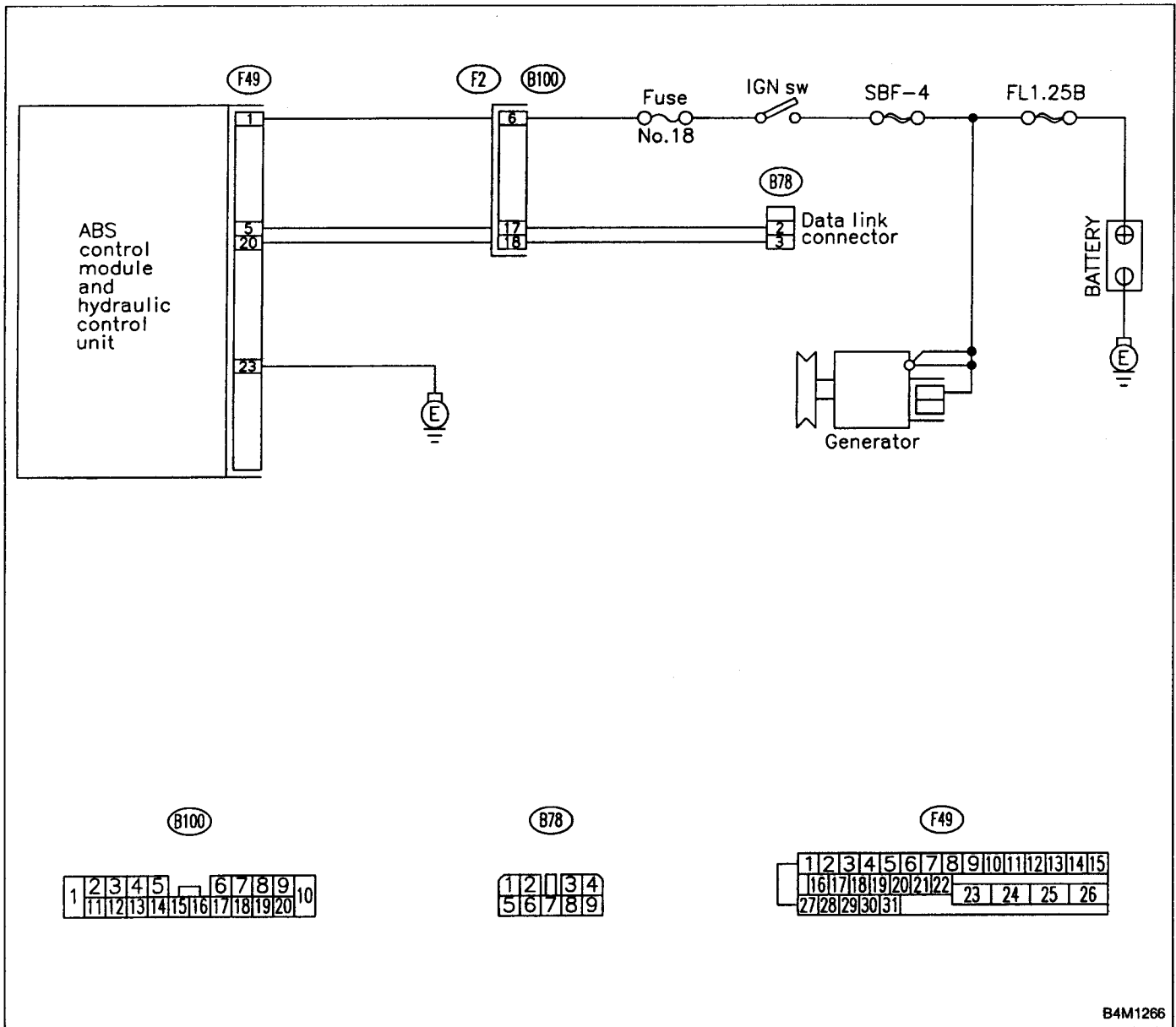

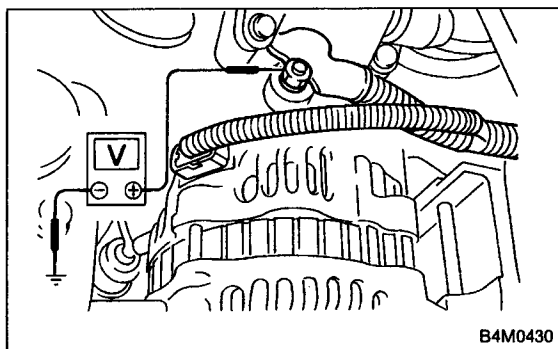
**10C1 CHECK GENERATOR.**

- 1) Start the engine.
- 2) Idle the engine.
- 3) Measure voltage between generator and chassis ground.

**Terminal**

**Generator B terminal (+) — Chassis ground (-):**

**CHECK** : *Is the voltage between 10 and 15 V?*

**YES** : Go to step **10C2**.

**NO** : Repair generator.

**10C2 CHECK BATTERY TERMINAL.**

Turn ignition switch to OFF.

**CHECK** : *Is there poor contact at battery terminal?*

**YES** : Repair battery terminal.

**NO** : Go to step **10C3**.

**10C3 CHECK COMMUNICATION OF SELECT MONITOR.**

Using the select monitor, check whether communication to other system (such as engine, AT, etc.) can be executed normally.

**CHECK** : *Are the name and year of the system displayed on the select monitor?*

**YES** : Go to step **10C4**.

**NO** : Repair select monitor communication cable and connector.

**10C4 CHECK INSTALLATION OF ABSCM&H/U CONNECTOR.**

Turn ignition switch to OFF.

**CHECK** : *Is ABSCM&H/U connector inserted into ABSCM&H/U until the clamp locks onto it?*

**YES** : Go to step **10C5**.

**NO** : Insert ABSCM&H/U connector into ABSCM&H/U until the clamp locks onto it.

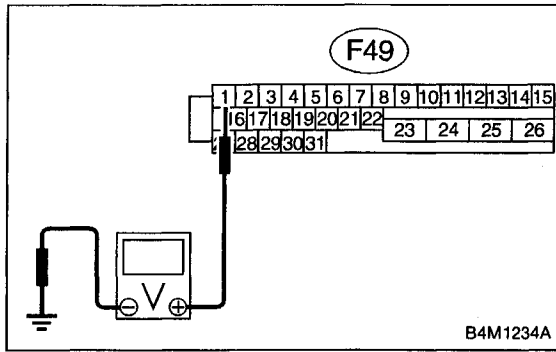

**10C5 CHECK POWER SUPPLY OF ABSCM&H/U.**

- 1) Disconnect connector from ABSCM&H/U.
- 2) Start engine.
- 3) Idle the engine.
- 4) Measure voltage between ABSCM&H/U connector and chassis ground.

**Connector & terminal**

**(F49) No. 1 (+) — Chassis ground (-):**

**CHECK** : Is the voltage between 10 and 15 V?

**YES** : Go to step 10C6.

**NO** : Repair ABSCM&H/U power supply circuit.

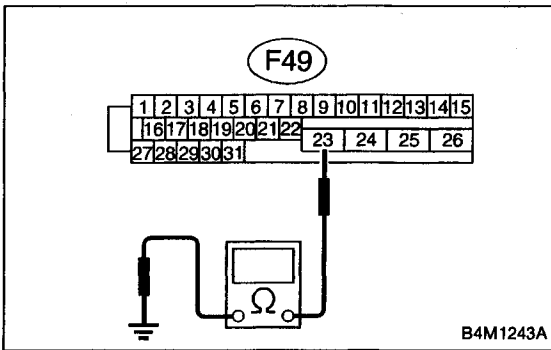

**10C6 CHECK GROUND CIRCUIT OF ABSCM&H/U.**

- 1) Turn ignition switch to OFF.
- 2) Measure resistance between ABSCM&H/U connector and chassis ground.

**Connector & terminal**

**(F49) No. 23 — Chassis ground:**

**CHECK** : Is the resistance less than 0.5 Ω?

**YES** : Repair harness/connector between ABSCM&H/U and select monitor.

**NO** : Go to step 10C7.

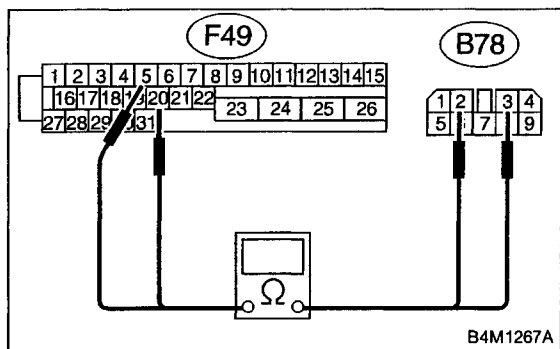

<b>10C7</b>	<b>CHECK HARNESS/CONNECTOR BETWEEN ABSCM&amp;H/U AND DATA LINK CONNECTOR.</b>
-------------	---

- 1) Turn ignition switch OFF.
- 2) Measure resistance between ABSCM&H/U connector and data link connector.

**Connector & terminal**

**(F49) No. 20 — (B78) No. 3:**

**(F49) No. 5 — (B78) No. 2:**

**CHECK** : **Is the resistance less than 0.5 Ω?**

**YES** : Repair harness and connector between ABSCM&H/U and data link connector.

**NO** : Go to step **10C8**.

<b>10C8</b>	<b>CHECK POOR CONTACT IN CONNECTORS.</b>
-------------	--

**CHECK** : **Is there poor contact in connectors between ABSCM&H/U and data link connector? <Ref. to FOREWORD [T3C1].☆10>**

**YES** : Repair connector.

**NO** : Replace ABSCM&H/U.

D•ALL 11 (FB1)  
NO TROUBLE

B4M0944

**D: NO TROUBLE**  
— ALTHOUGH NO TROUBLE APPEARS ON THE SELECT MONITOR DISPLAY, THE ABS WARNING LIGHT REMAINS ON —

**DIAGNOSIS:**

- ABS warning light circuit is shorted.

**TROUBLE SYMPTOM:**

- ABS warning light remains on.
- NO TROUBLE displayed on the select monitor.

**NOTE:**

When the ABS warning light is OFF and "NO TROUBLE" is displayed on the select monitor, the system is in normal condition.

**WIRING DIAGRAM:**

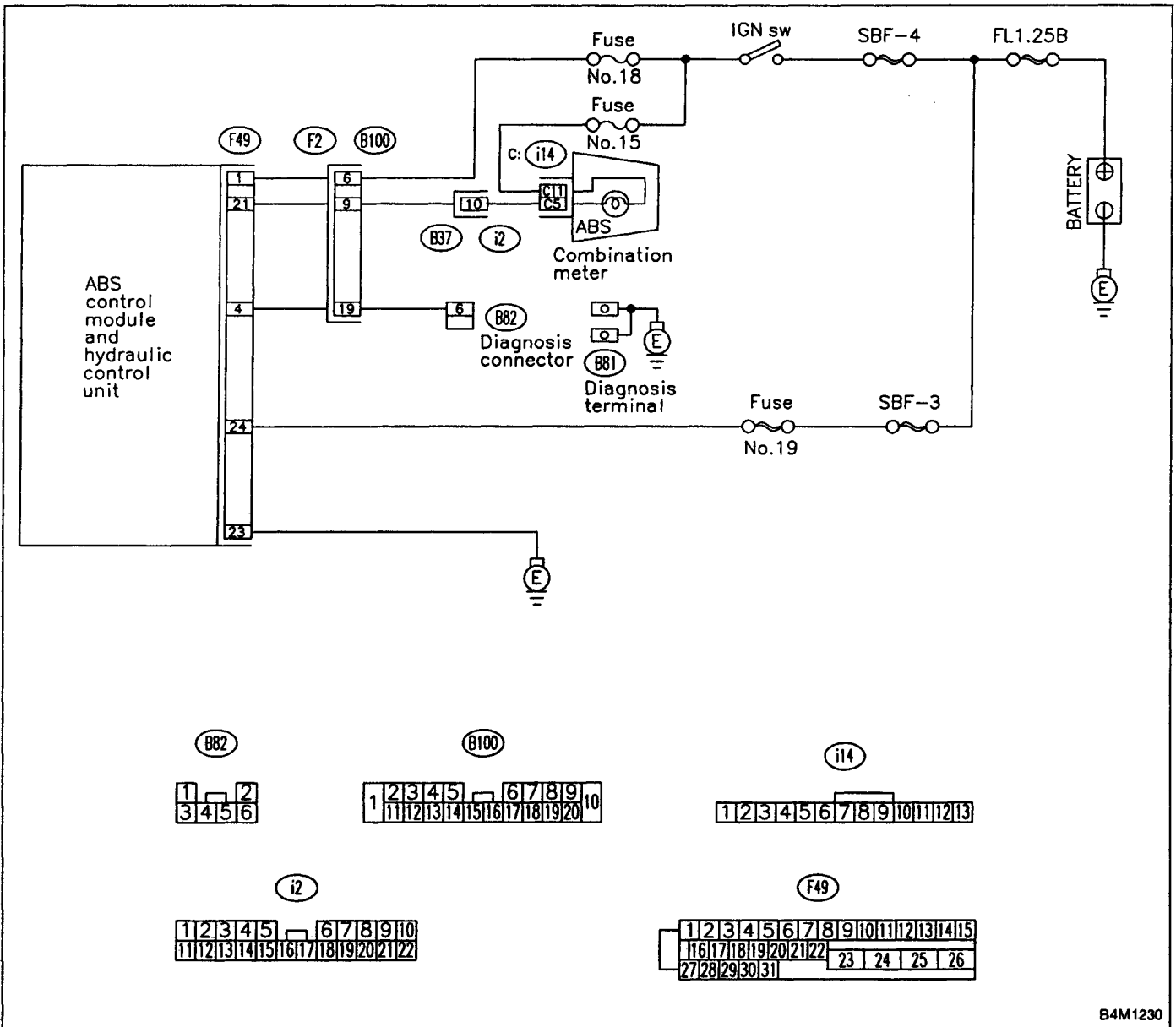

<b>10D1</b>	<b>CHECK WIRING HARNESS.</b>
-------------	------------------------------

- 1) Turn ignition switch to OFF.
- 2) Disconnect connector (F2) from connector (B100).
- 3) Turn ignition switch to ON.

**CHECK** : **Does the ABS warning light remain off?**

**YES** : Go to step **10D2**.

**NO** : Repair front wiring harness.

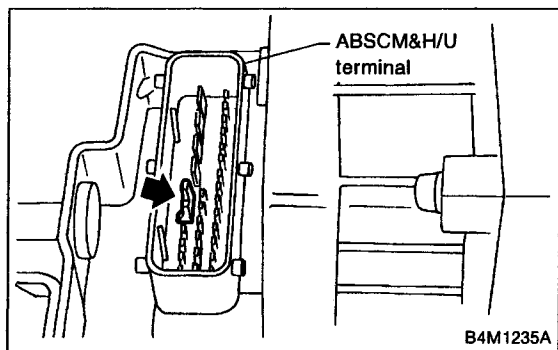

<b>10D2</b>	<b>CHECK PROJECTION AT ABSCM&amp;H/U.</b>
-------------	---

- 1) Turn ignition switch to OFF.
- 2) Disconnect connector from ABSCM&H/U.
- 3) Check for broken projection at the ABSCM&H/U terminal.

**CHECK** : **Are the projection broken?**

**YES** : Go to step **10D3**.

**NO** : Replace ABSCM&H/U.

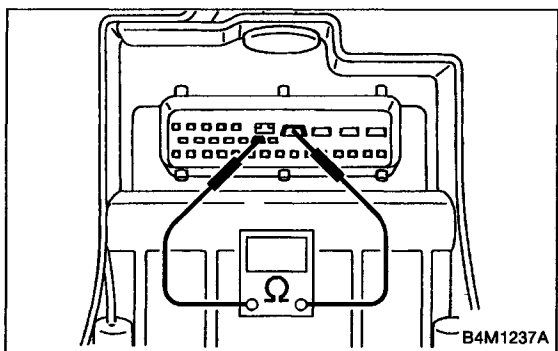

<b>10D3</b>	<b>CHECK ABSCM&amp;H/U.</b>
-------------	-----------------------------

Measure resistance between ABSCM&H/U terminals.

**Terminals**

**No. 21 — No. 23:**

**CHECK** : **Is the resistance more than 1 MΩ?**

**YES** : Go to step **10D4**.

**NO** : Replace valve relay.

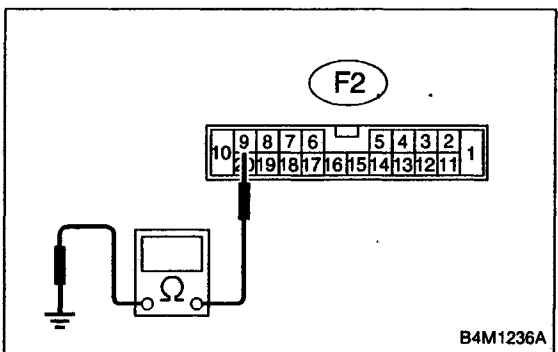

<b>10D4</b>	<b>CHECK WIRING HARNESS.</b>
-------------	------------------------------

Measure resistance between connector (F2) and chassis ground.

**Connector & terminal**

**(F2) No. 9 — Chassis ground:**

**CHECK** : **Is the resistance less than 0.5 Ω?**

**YES** : Go to step **10D5**.

**NO** : Repair harness.

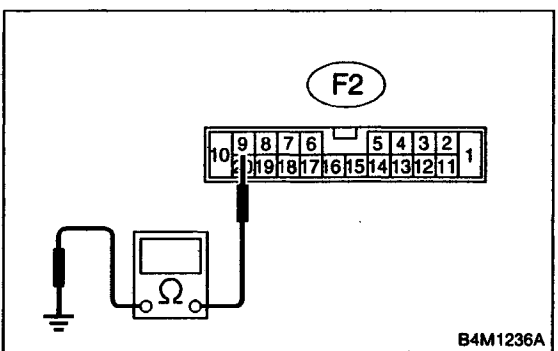

<b>10D5</b>	<b>CHECK WIRING HARNESS.</b>
-------------	------------------------------

- 1) Connect connector to ABSCM&H/U.
- 2) Measure resistance between connector (F2) and chassis ground.

**Connector & terminal**

**(F2) No. 9 — Chassis ground:**

**CHECK** : **Is the resistance more than 1 MΩ?**

**YES** : Go to step **10D6**.

**NO** : Repair harness.



10D6	CHECK POOR CONTACT IN ABSCM&H/U CONNECTOR.
------	--

**CHECK** : *Is there poor contact in ABSCM&H/U connector? <Ref. to FOREWORD [T3C1].☆10>*

**YES** : Repair connector.

**NO** : Replace ABSCM&H/U.

D•NEW 21 (FB1)  
FR. SS HARD

B4M0945

**E: TROUBLE CODE 21 FR. SS HARD**  
— ABNORMAL FRONT RH ABS SENSOR  
(OPEN CIRCUIT OR INPUT VOLTAGE TOO  
HIGH) —

D•NEW 23 (FB1)  
FL. SS HARD

B4M0946

**F: TROUBLE CODE 23 FL. SS HARD**  
— ABNORMAL FRONT LH ABS SENSOR  
(OPEN CIRCUIT OR INPUT VOLTAGE TOO  
HIGH) —

D•NEW 25 (FB1)  
RR. SS HARD

B4M0947

**G: TROUBLE CODE 25 RR. SS HARD**  
— ABNORMAL REAR RH ABS SENSOR (OPEN  
CIRCUIT OR INPUT VOLTAGE TOO HIGH) —

D•NEW 27 (FB1)  
RL. SS HARD

B4M0948

**H: TROUBLE CODE 27 RL. SS HARD**  
— ABNORMAL REAR LH ABS SENSOR (OPEN  
CIRCUIT OR INPUT VOLTAGE TOO HIGH) —

**DIAGNOSIS:**

- Faulty ABS sensor (Broken wire, input voltage too high)
- Faulty harness connector

**TROUBLE SYMPTOM:**

- ABS does not operate.

**WIRING DIAGRAM:**

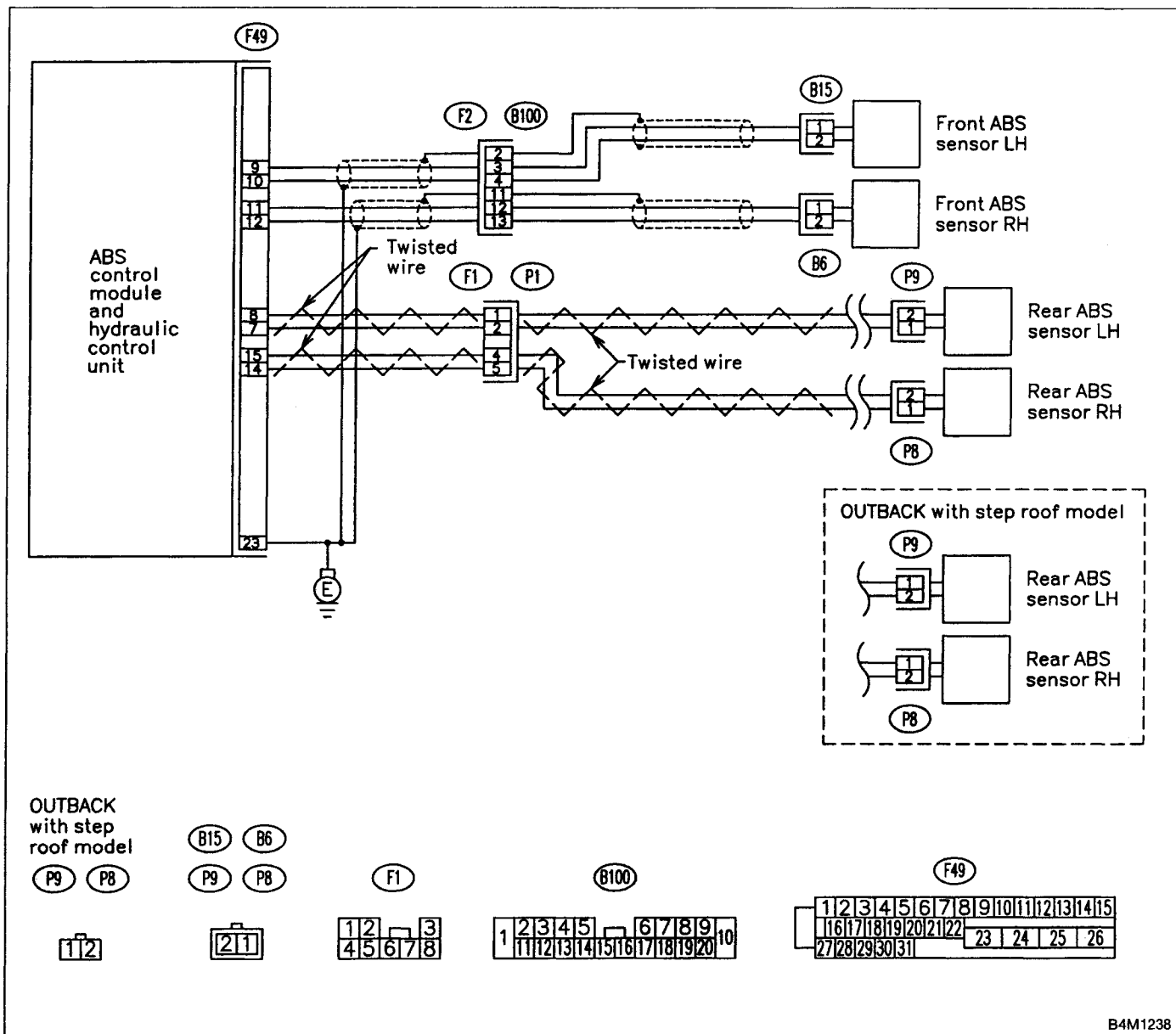

B4M1238

<p>FR (F05) 30 km/h</p> <p style="text-align: right; font-size: small;">B4M0922</p>
---

**10H1****CHECK OUTPUT OF ABS SENSOR USING SELECT MONITOR.**

Read the ABS sensor output corresponding to the faulty system in the select monitor function mode.

NOTE:

The select monitor display shows that the front right wheel is rotating at 30 km/h.

**CHECK** : *Does the speed indicated on the display change in response to the speedometer reading during acceleration/deceleration when the steering wheel is in the straight-ahead position?*

**YES** : Go to step **10H2**.

**NO** : Go to step **10H9**.

**10H2****CHECK INSTALLATION OF ABS SENSOR.****Tightening torque:**

**32 ± 10 N·m (3.3 ± 1.0 kg-m, 24 ± 7 ft-lb)**

**CHECK** : *Are the ABS sensor installation bolts tightened securely?*

**YES** : Go to step **10H3**.

**NO** : Tighten ABS sensor installation bolts securely.

**10H3****CHECK INSTALLATION OF TONE WHEEL.****Tightening torque:**

**13 ± 3 N·m (1.3 ± 0.3 kg-m, 9 ± 2.2 ft-lb)**

**CHECK** : *Are the tone wheel installation bolts tightened securely?*

**YES** : Go to step **10H4**.

**NO** : Tighten tone wheel installation bolts securely.

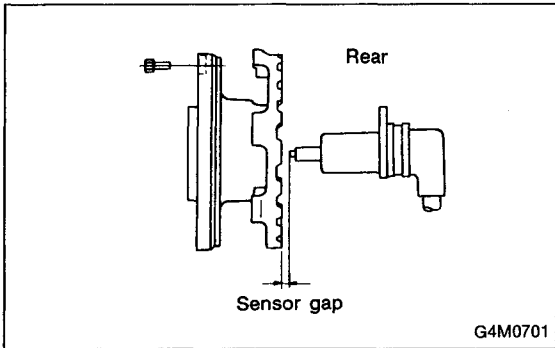
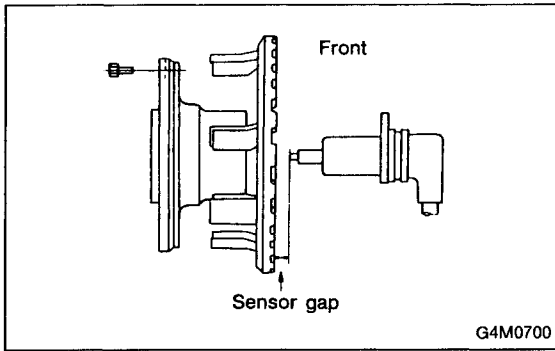

**10H4 CHECK ABS SENSOR GAP.**

Measure tone wheel-to-pole piece gap over entire perimeter of the wheel.

**CHECK** : *Is the gap within the specifications shown in the following table?*

Specifications	Front wheel	Rear wheel
		0.9 — 1.4 mm (0.035 — 0.055 in)

**YES** : Go to step **10H5**.

**NO** : Adjust the gap.

NOTE:

Adjust the gap using spacers (Part No. 26755AA000). If spacers cannot correct the gap, replace worn sensor or worn tone wheel.

**10H5 CHECK HUB RUNOUT.**

Measure hub runout.

**CHECK** : *Is the runout less than 0.05 mm (0.0020 in)?*

**YES** : Go to step **10H6**.

**NO** : Repair hub.

**10H6 CHECK POOR CONTACT IN CONNECTORS.**

Turn ignition switch to OFF.

**CHECK** : *Is there poor contact in connectors between ABSCM&H/U and ABS sensor? <Ref. to FOREWORD [T3C1].☆10>*

**YES** : Repair connector.

**NO** : Go to step **10H7**.

**10H7 CHECK ABSCM&H/U.**

- 1) Connect all connectors.
- 2) Erase the memory.
- 3) Perform inspection mode.
- 4) Read out the trouble code.

**CHECK** : *Is the same trouble code as in the current diagnosis still being output?*

**YES** : Replace ABSCM&H/U.

**NO** : Go to step **10H8**.

10H8

**CHECK ANY OTHER TROUBLE CODES APPEARANCE.**

**CHECK**

: Are other trouble codes being output?

**YES**

: Proceed with the diagnosis corresponding to the trouble code.

**NO**

: A temporary poor contact.

NOTE:

Check harness and connectors between ABSCM&H/U and ABS sensor.

10H9

**CHECK ABS SENSOR.**

- 1) Turn ignition switch to OFF.
- 2) Disconnect connector from ABS sensor.
- 3) Measure resistance of ABS sensor connector terminals.

**Terminal**

**Front RH No. 1 — No. 2:**

**Front LH No. 1 — No. 2:**

**Rear RH No. 1 — No. 2:**

**Rear LH No. 1 — No. 2:**

**CHECK**

: Is the resistance between 0.8 and 1.2 kΩ?

**YES**

: Go to step 10H10.

**NO**

: Replace ABS sensor.

10H10

**CHECK BATTERY SHORT OF ABS SENSOR.**

- 1) Disconnect connector from ABSCM&H/U.
- 2) Measure voltage between ABS sensor and chassis ground.

**Terminal**

**Front RH No. 1 (+) — Chassis ground (-):**

**Front LH No. 1 (+) — Chassis ground (-):**

**Rear RH No. 1 (+) — Chassis ground (-):**

**Rear LH No. 1 (+) — Chassis ground (-):**

**CHECK**

: Is the voltage less than 1 V?

**YES**

: Go to step 10H11.

**NO**

: Replace ABS sensor.

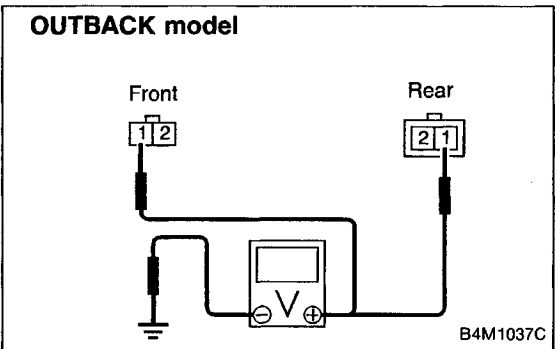
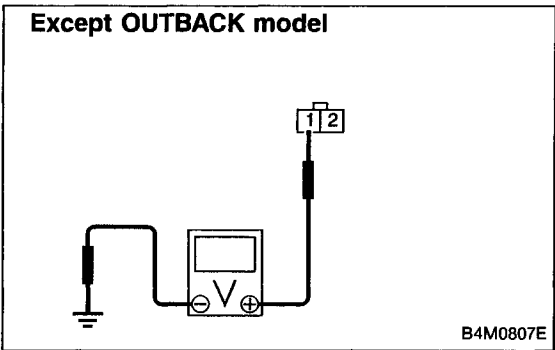
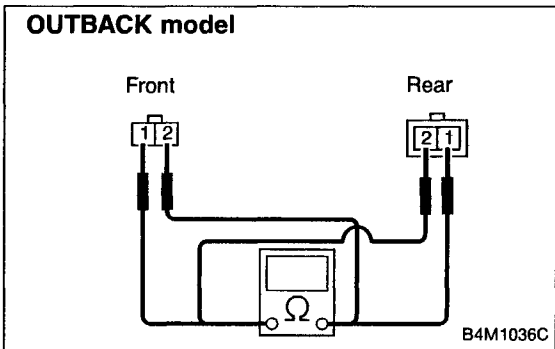
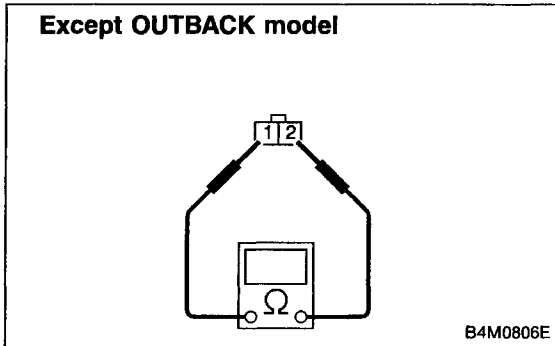

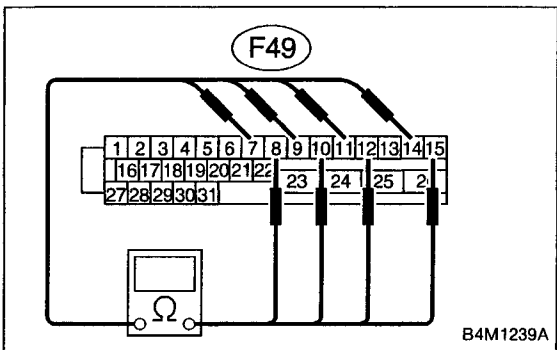
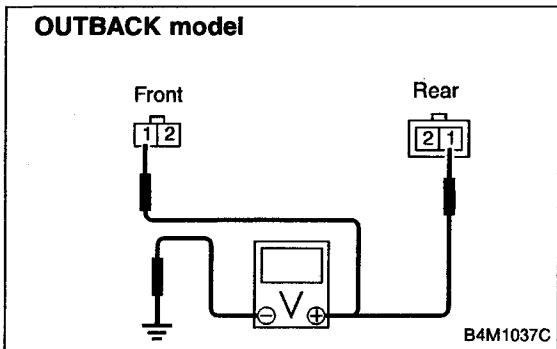
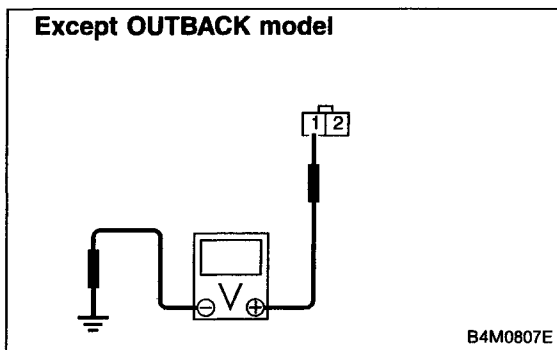

**10H11 CHECK BATTERY SHORT OF ABS SENSOR.**

- 1) Turn ignition switch to ON.
- 2) Measure voltage between ABS sensor and chassis ground.

**Terminal**

**Front RH No. 1 (+) — Chassis ground (-):**

**Front LH No. 1 (+) — Chassis ground (-):**

**Rear RH No. 1 (+) — Chassis ground (-):**

**Rear LH No. 1 (+) — Chassis ground (-):**

**CHECK** : Is the voltage less than 1 V?

**YES** : Go to step **10H12**.

**NO** : Replace ABS sensor.

**10H12 CHECK HARNESS/CONNECTOR BETWEEN ABSCM&H/U AND ABS SENSOR.**

- 1) Turn ignition switch to OFF.
- 2) Connect connector to ABS sensor.
- 3) Measure resistance between ABSCM&H/U connector terminals.

**Connector & terminal**

**Trouble code 21 / (F49) No. 11 — No. 12:**

**Trouble code 23 / (F49) No. 9 — No. 10:**

**Trouble code 25 / (F49) No. 14 — No. 15:**

**Trouble code 27 / (F49) No. 7 — No. 8:**

**CHECK** : Is the resistance between 0.8 and 1.2 kΩ?

**YES** : Go to step **10H13**.

**NO** : Repair harness/connector between ABSCM&H/U and ABS sensor.

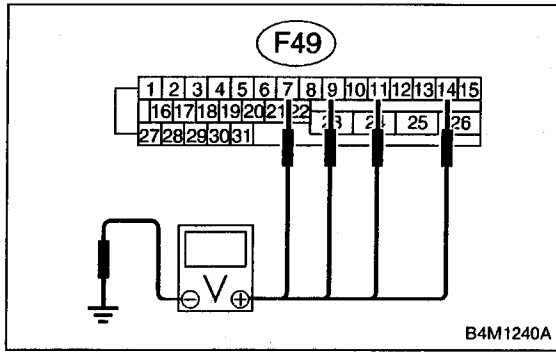

**10H13 CHECK BATTERY SHORT OF HARNESS.**

Measure voltage between ABSCM&H/U connector and chassis ground.

- Connector & terminal**  
**Trouble code 21 / (F49) No. 11 (+) — Chassis ground (-):**  
**Trouble code 23 / (F49) No. 9 (+) — Chassis ground (-):**  
**Trouble code 25 / (F49) No. 14 (+) — Chassis ground (-):**  
**Trouble code 27 / (F49) No. 7 (+) — Chassis ground (-):**

- CHECK** : Is the voltage less than 1 V?  
**YES** : Go to step **10H14**.  
**NO** : Repair harness between ABSCM&H/U and ABS sensor.

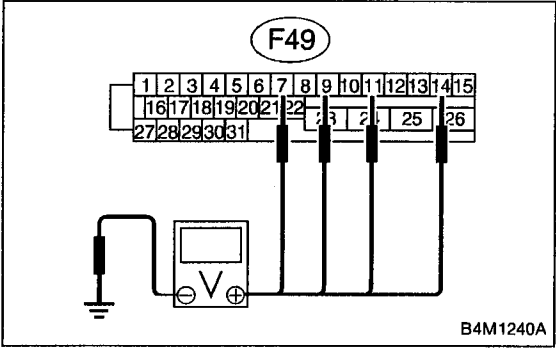

**10H14 CHECK BATTERY SHORT OF HARNESS.**

- 1) Turn ignition switch to ON.
- 2) Measure voltage between ABSCM&H/U connector and chassis ground.

- Connector & terminal**  
**Trouble code 21 / (F49) No. 11 (+) — Chassis ground (-):**  
**Trouble code 23 / (F49) No. 9 (+) — Chassis ground (-):**  
**Trouble code 25 / (F49) No. 14 (+) — Chassis ground (-):**  
**Trouble code 27 / (F49) No. 7 (+) — Chassis ground (-):**

- CHECK** : Is the voltage less than 1 V?  
**YES** : Go to step **10H15**.  
**NO** : Repair harness between ABSCM&H/U and ABS sensor.

**10H15 CHECK INSTALLATION OF ABS SENSOR.**

**Tightening torque:**  
**32 ± 10 N·m (3.3 ± 1.0 kg·m, 24 ± 7 ft·lb)**

- CHECK** : Are the ABS sensor installation bolts tightened securely?  
**YES** : Go to step **10H16**.  
**NO** : Tighten ABS sensor installation bolts securely.



**10H16 CHECK INSTALLATION OF TONE WHEEL.**

**Tightening torque:**

**13 ± 3 N·m (1.3 ± 0.3 kg·m, 9 ± 2.2 ft·lb)**

**CHECK** : Are the tone wheel installation bolts tightened securely?

**YES** : Go to step **10H17**.

**NO** : Tighten tone wheel installation bolts securely.

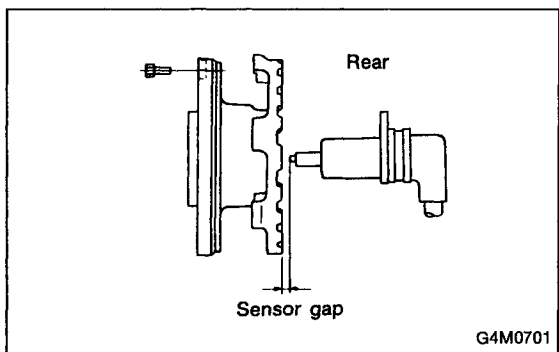
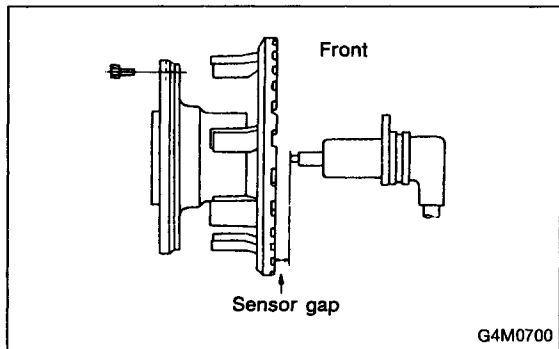

**10H17 CHECK ABS SENSOR GAP.**

Measure tone wheel-to-pole piece gap over entire perimeter of the wheel.

**CHECK** : Is the gap within the specifications shown in the following table?

	Front wheel	Rear wheel
Specifications	0.9 — 1.4 mm (0.035 — 0.055 in)	0.7 — 1.2 mm (0.028 — 0.047 in)

**YES** : Go to step **10H18**.

**NO** : Adjust the gap.

**NOTE:**

Adjust the gap using spacers (Part No. 26755AA000). If spacers cannot correct the gap, replace worn sensor or worn tone wheel.

**10H18 CHECK HUB RUNOUT.**

Measure hub runout.

**CHECK** : Is the runout less than 0.05 mm (0.0020 in)?

**YES** : Go to step **10H19**.

**NO** : Repair hub.

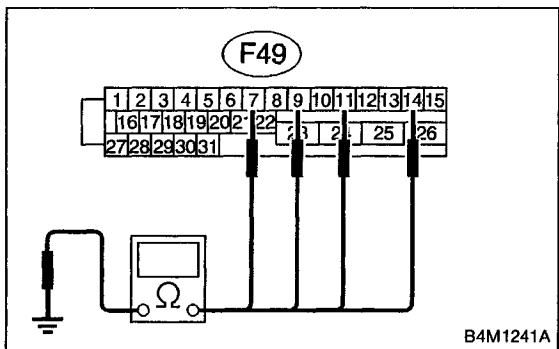
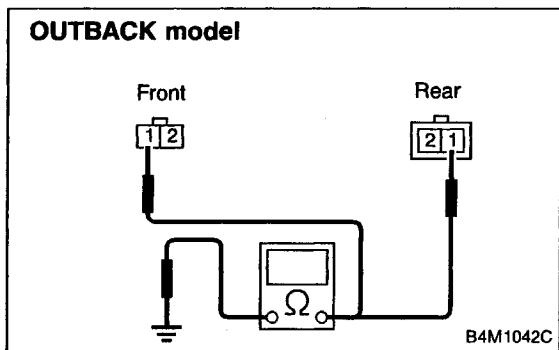
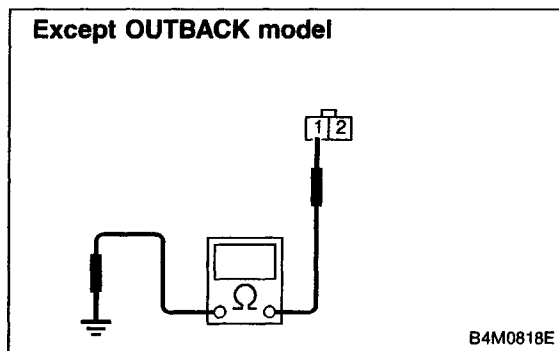

<b>10H19</b>	<b>CHECK GROUND SHORT OF ABS SENSOR.</b>
--------------	--

- 1) Turn ignition switch to ON.
- 2) Measure resistance between ABS sensor and chassis ground.

**Terminal****Front RH No. 1 — Chassis ground:****Front LH No. 1 — Chassis ground:****Rear RH No. 1 — Chassis ground:****Rear LH No. 1 — Chassis ground:****CHECK** : Is the resistance more than 1 MΩ?**YES** : Go to step **10H20**.**NO** : Replace ABS sensor and ABSCM&H/U.

<b>10H20</b>	<b>CHECK GROUND SHORT OF HARNESS.</b>
--------------	---------------------------------------

- 1) Turn ignition switch to OFF.
- 2) Connect connector to ABS sensor.
- 3) Measure resistance between ABSCM&H/U connector terminal and chassis ground.

**Connector & terminal****Trouble code 21 / (F49) No. 11 — Chassis ground:****Trouble code 23 / (F49) No. 9 — Chassis ground:****Trouble code 25 / (F49) No. 14 — Chassis ground:****Trouble code 27 / (F49) No. 7 — Chassis ground:****CHECK** : Is the resistance more than 1 MΩ?**YES** : Go to step **10H21**.**NO** : Repair harness between ABSCM&H/U and ABS sensor.

And replace ABSCM&amp;H/U.

<b>10H21</b>	<b>CHECK POOR CONTACT IN CONNECTORS.</b>
--------------	--

**CHECK** : Is there poor contact in connectors between ABSCM&H/U and ABS sensor? <Ref. to FOREWORD [T3C1].☆10>**YES** : Repair connector.**NO** : Go to step **10H22**.

<b>10H22</b>	<b>CHECK ABSCM&amp;H/U.</b>
--------------	-----------------------------

- 1) Connect all connectors.
- 2) Erase the memory.
- 3) Perform inspection mode.
- 4) Read out the trouble code.

**CHECK** : *Is the same trouble code as in the current diagnosis still being output?*

**YES** : Replace ABSCM&H/U.

**NO** : Go to step **10H23**.

<b>10H23</b>	<b>CHECK ANY OTHER TROUBLE CODES APPEARANCE.</b>
--------------	--

**CHECK** : *Are other trouble codes being output?*

**YES** : Proceed with the diagnosis corresponding to the trouble code.

**NO** : A temporary poor contact.

NOTE:

Check harness and connectors between ABSCM&H/U and ABS sensor.

D•NEW 22 (FB1)  
FR. SS SOFT

B4M0812

**I: TROUBLE CODE 22 FR. SS SOFT  
— ABNORMAL FRONT RH ABS SENSOR  
(ABNORMAL ABS SENSOR SIGNAL) —**

D•NEW 24 (FB1)  
FL. SS SOFT

B4M0949

**J: TROUBLE CODE 24 FL. SS SOFT  
— ABNORMAL FRONT LH ABS SENSOR  
(ABNORMAL ABS SENSOR SIGNAL) —**

D•NEW 26 (FB1)  
RR. SS SOFT

B4M0950

**K: TROUBLE CODE 26 RR. SS SOFT  
— ABNORMAL REAR RH ABS SENSOR  
(ABNORMAL ABS SENSOR SIGNAL) —**

D•NEW 28 (FB1)  
RL. SS SOFT

B4M0951

**L: TROUBLE CODE 28 RL. SS SOFT  
— ABNORMAL REAR LH ABS SENSOR  
(ABNORMAL ABS SENSOR SIGNAL) —**

**DIAGNOSIS:**

- Faulty ABS sensor signal (noise, irregular signal, etc.)
- Faulty harness/connector

**TROUBLE SYMPTOM:**

- ABS does not operate.

**WIRING DIAGRAM:**

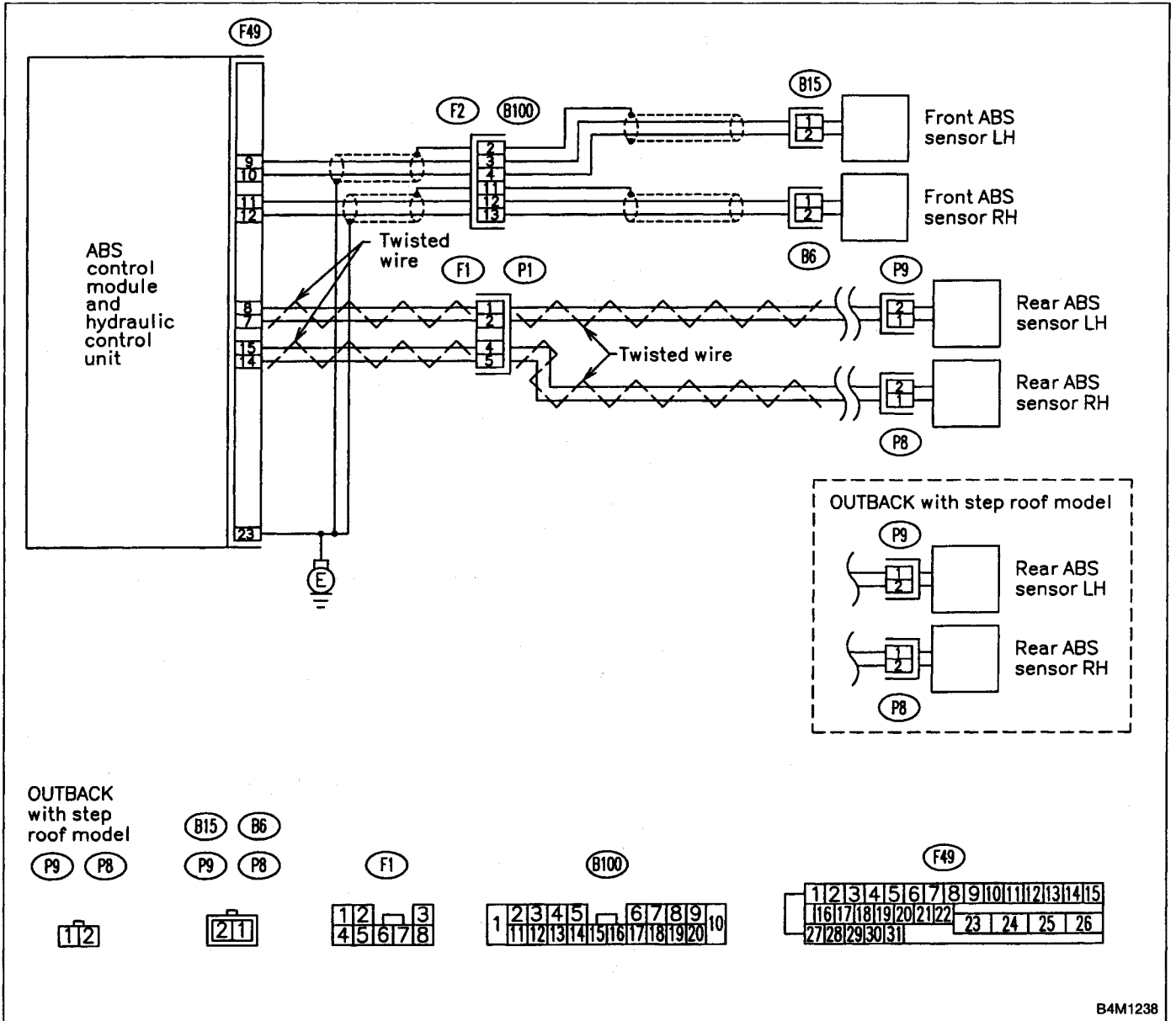

B4M1238

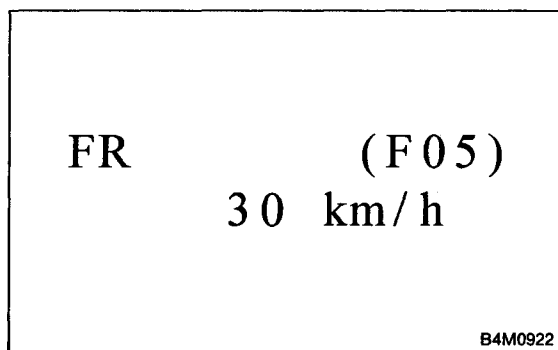
**10L1****CHECK OUTPUT OF ABS SENSOR USING SELECT MONITOR.**

Read the ABS sensor output corresponding to the faulty system in the select monitor function mode.

NOTE:

The select monitor display shows that the front right wheel is rotating at 30 km/h.

**CHECK** : *Does the speed indicated on the display change in response to the speedometer reading during acceleration/deceleration when the steering wheel is in the straight-ahead position?*

**YES** : Go to step **10L2**.

**NO** : Go to step **10L8**.

**10L2****CHECK POOR CONTACT IN CONNECTORS.**

Turn ignition switch to OFF.

**CHECK** : *Is there poor contact in connectors between ABSCM&HIU and ABS sensor?*

**YES** : Repair connector.

**NO** : Go to step **10L3**.

**10L3****CHECK SOURCES OF SIGNAL NOISE.**

**CHECK** : *Is the car telephone or the wireless transmitter properly installed?*

**YES** : Go to step **10L4**.

**NO** : Properly install the car telephone or the wireless transmitter.

**10L4****CHECK SOURCES OF SIGNAL NOISE.**

**CHECK** : *Are noise sources (such as an antenna) installed near the sensor harness?*

**YES** : Install the noise sources apart from the sensor harness.

**NO** : Go to step **10L5**.

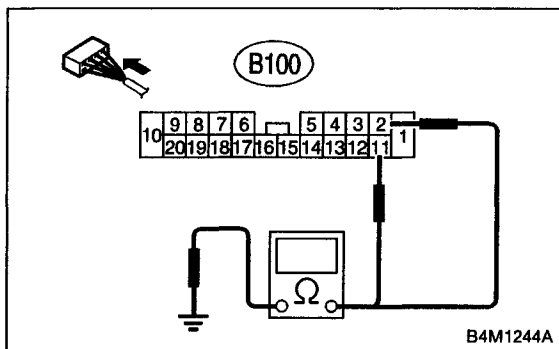

**10L5 CHECK SHIELD CIRCUIT.**

- 1) Turn ignition switch to OFF.
- 2) Connect all connectors.
- 3) Measure resistance between shield connector and chassis ground.

**Connector & terminal**  
**Trouble code 22 / (B100) No. 11 — Chassis ground:**  
**Trouble code 24 / (B100) No. 2 — Chassis ground:**  
**Trouble code 26 / Go to step 10L6.**  
**Trouble code 28 / Go to step 10L6.**

- CHECK** : Is the resistance less than 0.5 Ω?  
**YES** : Go to step **10L6**.  
**NO** : Repair shield harness.

**10L6 CHECK ABSCM&H/U.**

- 1) Connect all connectors.
- 2) Erase the memory.
- 3) Perform inspection mode.
- 4) Read out the trouble code.

- CHECK** : Is the same trouble code as in the current diagnosis still being output?  
**YES** : Replace ABSCM&H/U.  
**NO** : Go to step **10L7**.

**10L7 CHECK ANY OTHER TROUBLE CODES APPEARANCE.**

- CHECK** : Are other trouble codes being output?  
**YES** : Proceed with the diagnosis corresponding to the trouble code.  
**NO** : A temporary noise interference.

**10L8 CHECK INSTALLATION OF ABS SENSOR.**

**Tightening torque:**  
**32 ± 10 N·m (3.3 ± 1.0 kg·m, 24 ± 7 ft·lb)**

- CHECK** : Are the ABS sensor installation bolts tightened securely?  
**YES** : Go to step **10L9**.  
**NO** : Tighten ABS sensor installation bolts securely.

**10L9 CHECK INSTALLATION OF TONE WHEEL.**

**Tightening torque:**

**13 ± 3 N·m (1.3 ± 0.3 kg·m, 9 ± 2.2 ft·lb)**

**CHECK** : Are the tone wheel installation bolts tightened securely?

**YES** : Go to step **10L10**.

**NO** : Tighten tone wheel installation bolts securely.

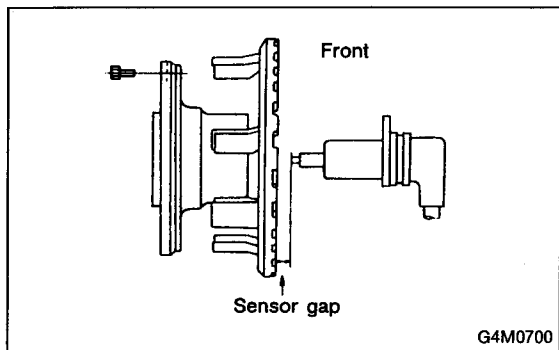

**10L10 CHECK ABS SENSOR GAP.**

Measure tone wheel to pole piece gap over entire perimeter of the wheel.

**CHECK** : Is the gap within the specifications shown in the following table?

	Front wheel	Rear wheel
Specifications	0.9 — 1.4 mm (0.035 — 0.055 in)	0.7 — 1.2 mm (0.028 — 0.047 in)

**YES** : Go to step **10L11**.

**NO** : Adjust the gap.

NOTE:

Adjust the gap using spacer (Part No. 26755AA000). If spacers cannot correct the gap, replace worn sensor or worn tone wheel.

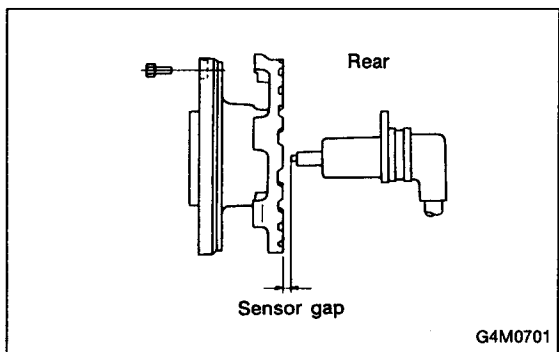

**10L11 CHECK OSCILLOSCOPE.**

**CHECK** : Is an oscilloscope available?

**YES** : Go to step **10L12**.

**NO** : Go to step **10L13**.

**10L12 CHECK ABS SENSOR SIGNAL.**

- 1) Raise all four wheels of ground.
- 2) Turn ignition switch OFF.
- 3) Connect the oscilloscope to the connector (F1) or connector (B100) in accordance with trouble code.
- 4) Turn ignition switch ON.



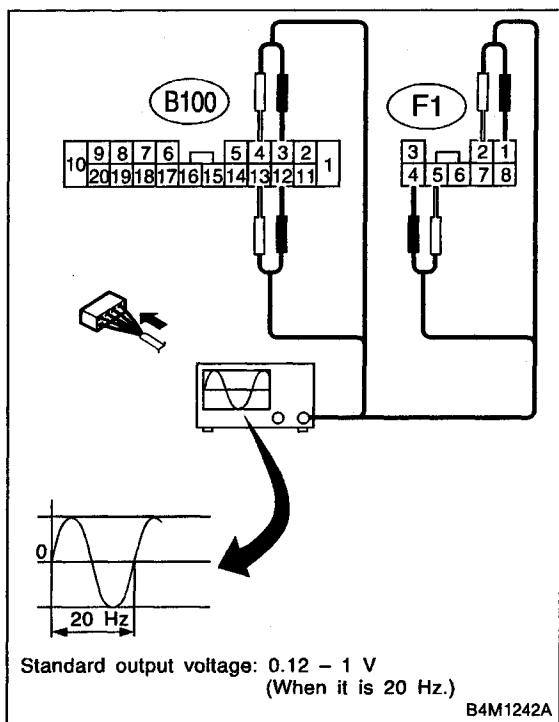

5) Rotate wheels and measure voltage at specified frequency.

NOTE:

When this inspection is completed, the ABSCM&H/U sometimes stores the trouble code 29.

**Connector & terminal**

**Trouble code 22 / (B100) No. 12 (+) — No. 13 (-):**

**Trouble code 24 / (B100) No. 3 (+) — No. 4 (-):**

**Trouble code 26 / (F1) No. 4 (+) — No. 5 (-):**

**Trouble code 28 / (F1) No. 1 (+) — No. 2 (-):**

**Specified voltage: 0.12 — 1 V (When it is 20 Hz.)**

**CHECK** : *Is oscilloscope pattern smooth, as shown in figure?*

**YES** : Go to step **10L16**.

**NO** : Go to step **10L13**.

<b>10L13</b>	<b>CHECK CONTAMINATION OF ABS SENSOR OR TONE WHEEL.</b>
--------------	---

Remove disc rotor or drum from hub in accordance with trouble code.

**CHECK** : *Is the ABS sensor pole piece or the tone wheel contaminated by dirt or other foreign matter?*

**YES** : Thoroughly remove dirt or other foreign matter.

**NO** : Go to step **10L14**.

<b>10L14</b>	<b>CHECK DAMAGE OF ABS SENSOR OR TONE WHEEL.</b>
--------------	--

**CHECK** : *Are there broken or damaged in the ABS sensor pole piece or the tone wheel?*

**YES** : Replace ABS sensor or tone wheel.

**NO** : Go to step **10L15**.

<b>10L15</b>	<b>CHECK HUB RUNOUT.</b>
--------------	--------------------------

Measure hub runout.

**CHECK** : *Is the runout less than 0.05 mm (0.0020 in)?*

**YES** : Go to step **10L16**.

**NO** : Repair hub.

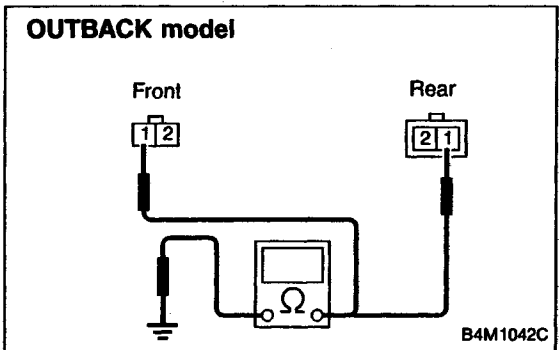
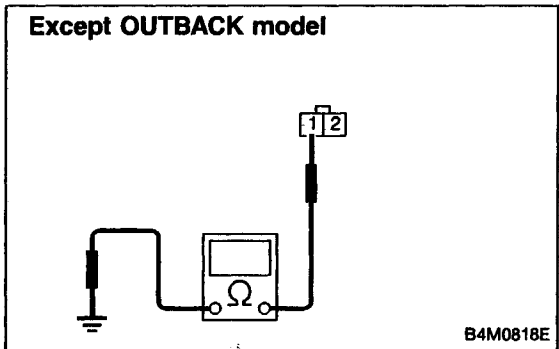
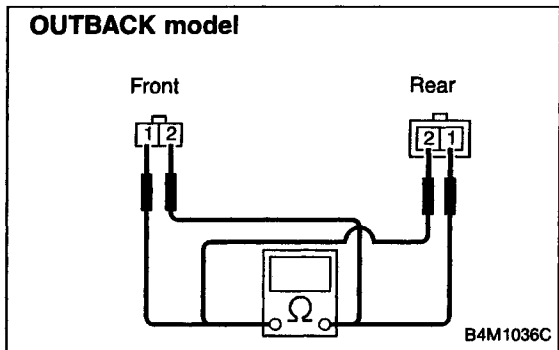
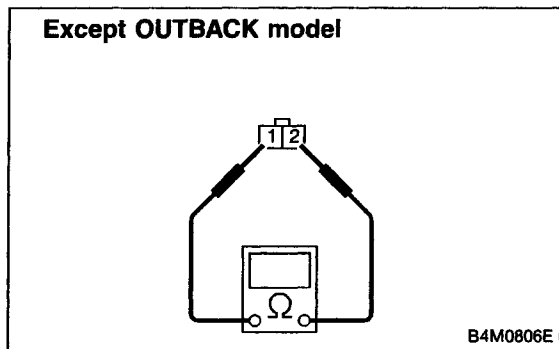

**10L16 CHECK RESISTANCE OF ABS SENSOR.**

- 1) Turn ignition switch OFF.
- 2) Disconnect connector from ABS sensor.
- 3) Measure resistance between ABS sensor connector terminals.

**Terminal**

**Front RH No. 1 — No. 2:**

**Front LH No. 1 — No. 2:**

**Rear RH No. 1 — No. 2:**

**Rear LH No. 1 — No. 2:**

**CHECK** : Is the resistance between 0.8 and 1.2 kΩ?

**YES** : Go to step 10L17.

**NO** : Replace ABS sensor.

**10L17 CHECK GROUND SHORT OF ABS SENSOR.**

Measure resistance between ABS sensor and chassis ground.

**Terminal**

**Front RH No. 1 — Chassis ground:**

**Front LH No. 1 — Chassis ground:**

**Rear RH No. 1 — Chassis ground:**

**Rear LH No. 1 — Chassis ground:**

**CHECK** : Is the resistance more than 1 MΩ?

**YES** : Go to step 10L18.

**NO** : Replace ABS sensor.

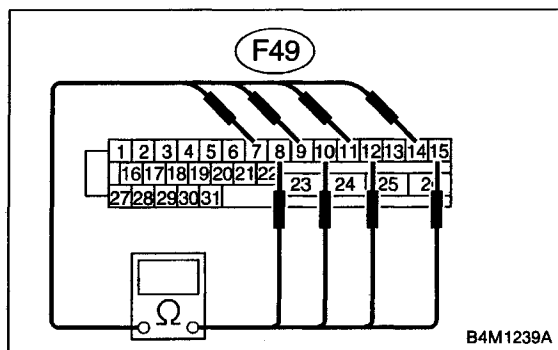

**10L18 CHECK HARNESS/CONNECTOR BETWEEN ABSCM&H/U AND ABS SENSOR.**

- 1) Connect connector to ABS sensor.
- 2) Disconnect connector from ABSCM&H/U.
- 3) Measure resistance at ABSCM&H/U connector terminals.

**Connector & terminal**

**Trouble code 22 I (F49) No. 11 — No. 12:**

**Trouble code 24 I (F49) No. 9 — No. 10:**

**Trouble code 26 I (F49) No. 14 — No. 15:**

**Trouble code 28 I (F49) No. 7 — No. 8:**

**CHECK** : Is the resistance between 0.8 and 1.2 kΩ?

**YES** : Go to step 10L19.

**NO** : Repair harness/connector between ABSCM&H/U and ABS sensor.

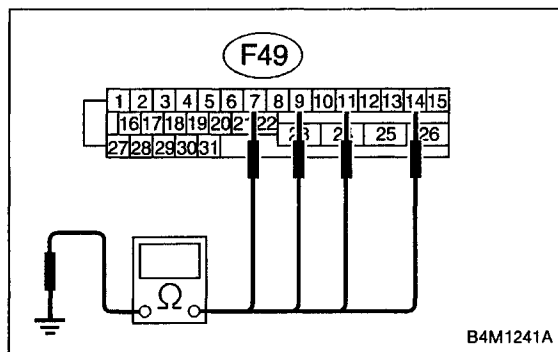

**10L19 CHECK GROUND SHORT OF HARNESS.**

Measure resistance between ABSCM&H/U connector and chassis ground.

**Connector & terminal**

**Trouble code 22 I (F49) No. 11 — Chassis ground:**

**Trouble code 24 I (F49) No. 9 — Chassis ground:**

**Trouble code 26 I (F49) No. 14 — Chassis ground:**

**Trouble code 28 I (F49) No. 7 — Chassis ground:**

**CHECK** : Is the resistance more than 1 MΩ?

**YES** : Go to step 10L20.

**NO** : Repair harness/connector between ABSCM&H/U and ABS sensor.

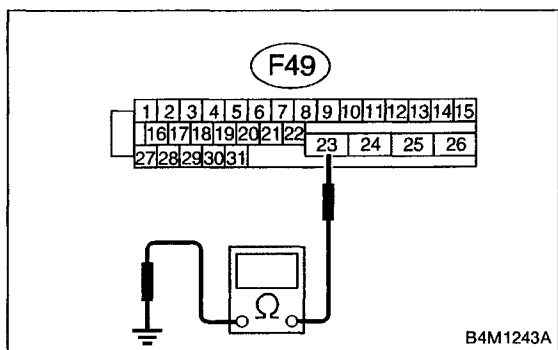

**10L20 CHECK GROUND CIRCUIT OF ABSCM&H/U.**

Measure resistance between ABSCM&H/U and chassis ground.

**Connector & terminal**

**(F49) No. 23 — GND:**

**CHECK** : Is the resistance less than 0.5 Ω?

**YES** : Go to step 10L21.

**NO** : Repair ABSCM&H/U ground harness.

**10L21 CHECK POOR CONTACT IN CONNECTORS.**

**CHECK** : Is there poor contact in connectors between ABSCM&HIU and ABS sensor? < Ref. to FOREWORD [T3C1].☆10 >

**YES** : Repair connector.

**NO** : Go to step 10L22.

**10L22 CHECK SOURCES OF SIGNAL NOISE.**

**CHECK** : Is the car telephone or the wireless transmitter properly installed?

**YES** : Go to step 10L23.

**NO** : Properly install the car telephone or the wireless transmitter.

**10L23 CHECK SOURCES OF SIGNAL NOISE.**

**CHECK** : Are noise sources (such as an antenna) installed near the sensor harness?

**YES** : Install the noise sources apart from the sensor harness.

**NO** : Go to step 10L24.

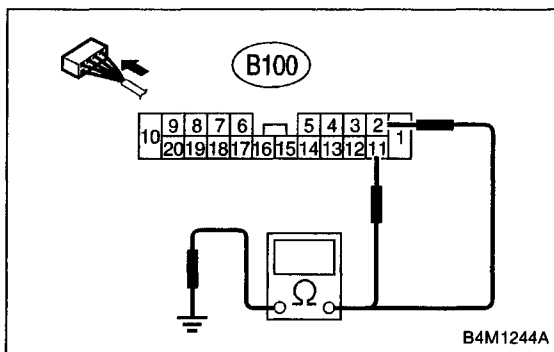
**10L24 CHECK SHIELD CIRCUIT.**

- 1) Connect all connectors.
- 2) Measure resistance between shield connector and chassis ground.

**Connector & terminal**

**Trouble code 22 / (B100) No. 11 — Chassis ground:**

**Trouble code 24 / (B100) No. 2 — Chassis ground:**

**Trouble code 26 / Go to step 10L25.**

**Trouble code 28 / Go to step 10L25.**

**CHECK** : Is the resistance less than 0.5 Ω?

**YES** : Go to step 10L25.

**NO** : Repair shield harness.

<b>10L25</b>	<b>CHECK ABSCM&amp;H/U.</b>
--------------	-----------------------------

- 1) Connect all connectors.
- 2) Erase the memory.
- 3) Perform inspection mode.
- 4) Read out the trouble code.

**CHECK** : *Is the same trouble code as in the current diagnosis still being output?*

**YES** : Replace ABSCM&H/U.

**NO** : Go to step **10L26**.

<b>10L26</b>	<b>CHECK ANY OTHER TROUBLE CODES APPEARANCE.</b>
--------------	--

**CHECK** : *Are other trouble codes being output?*

**YES** : Proceed with the diagnosis corresponding to the trouble code.

**NO** : A temporary noise interference.

D•NEW 29 (FB1)  
EITHER. SS SOFT

B4M0952

**M: TROUBLE CODE 29 EITHER. SS SOFT — ABNORMAL ABS SENSOR SIGNAL (ANY ONE OF FOUR) —**

**DIAGNOSIS:**

- Faulty ABS sensor signal (noise, irregular signal, etc.)
- Faulty tone wheel
- Wheels turning freely for a long time

**TROUBLE SYMPTOM:**

- ABS does not operate.

**WIRING DIAGRAM:**

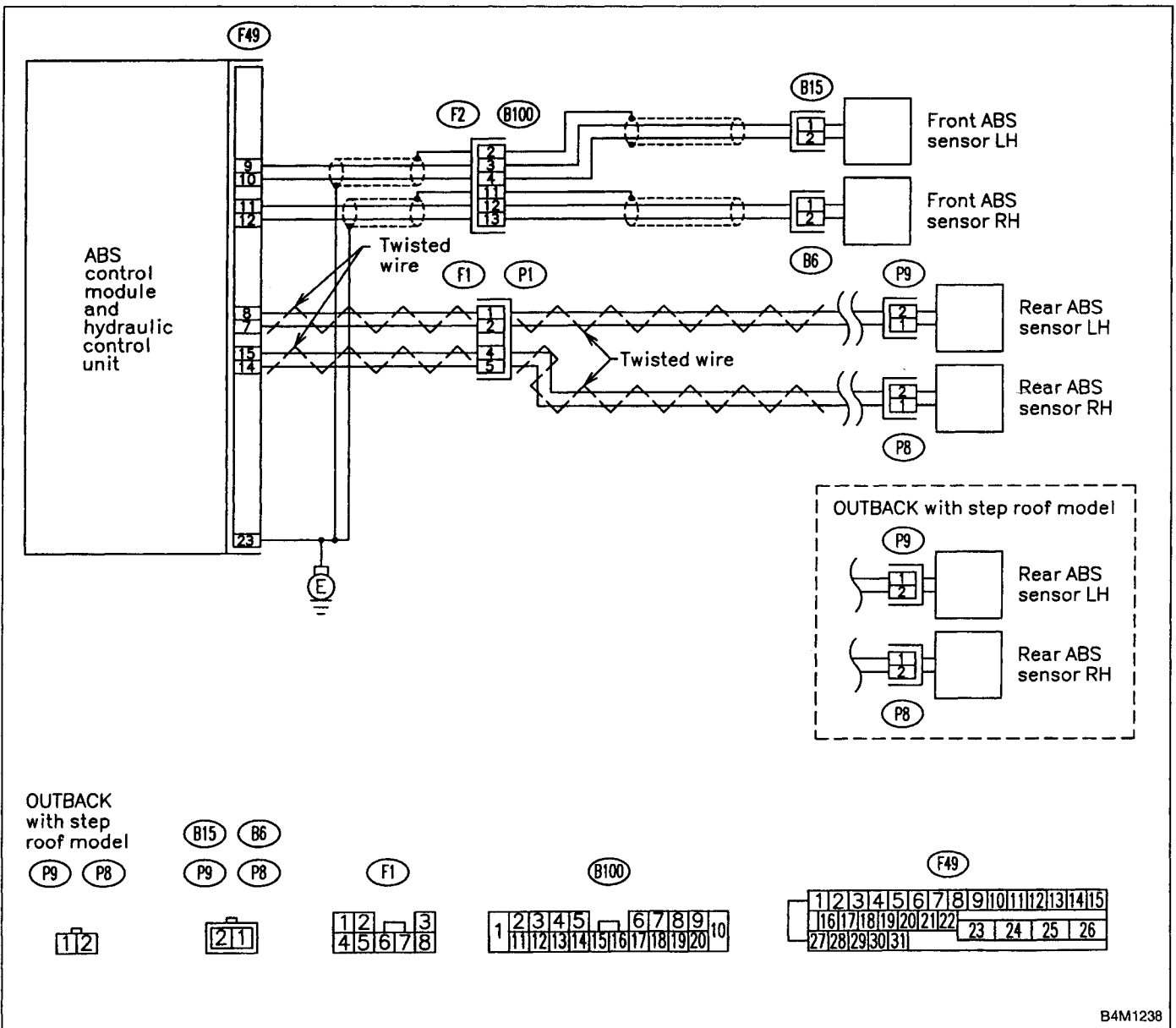

<b>10M1</b>	<b>CHECK IF THE WHEELS HAVE TURNED FREELY FOR A LONG TIME.</b>
-------------	--

**CHECK** : *Check if the wheels have been turned freely for more than one minute, such as when the vehicle is jacked-up, under full-lock cornering or when tire is not in contact with road surface.*

**YES** : The ABS is normal. Erase the trouble code.

NOTE:

When the wheels turn freely for a long time, such as when the vehicle is towed or jacked-up, or when steering wheel is continuously turned all the way, this trouble code may sometimes occur.

**NO** : Go to step **10M2**.

<b>10M2</b>	<b>CHECK TIRE SPECIFICATIONS.</b>
-------------	-----------------------------------

Turn ignition switch to OFF.

**CHECK** : *Are the tire specifications correct?*

**YES** : Go to step **10M3**.

**NO** : Replace tire.

<b>10M3</b>	<b>CHECK WEAR OF TIRE.</b>
-------------	----------------------------

**CHECK** : *Is the tire worn excessively?*

**YES** : Replace tire.

**NO** : Go to step **10M4**.

<b>10M4</b>	<b>CHECK TIRE PRESSURE.</b>
-------------	-----------------------------

**CHECK** : *Is the tire pressure correct?*

**YES** : Go to step **10M5**.

**NO** : Adjust tire pressure.

<b>10M5</b>	<b>CHECK INSTALLATION OF ABS SENSOR.</b>
-------------	--

**Tightening torque:**

**$32 \pm 10$  N·m ( $3.3 \pm 1.0$  kg·m,  $24 \pm 7$  ft·lb)**

**CHECK** : *Are the ABS sensor installation bolts tightened securely?*

**YES** : Go to step **10M6**.

**NO** : Tighten ABS sensor installation bolts securely.

**10M6 CHECK INSTALLATION OF TONE WHEEL.**

**Tightening torque:**

**13 ± 3 N·m (1.3 ± 0.3 kg-m, 9 ± 2.2 ft-lb)**

**CHECK** : Are the tone wheel installation bolts tightened securely?

**YES** : Go to step **10M7**.

**NO** : Tighten tone wheel installation bolts securely.

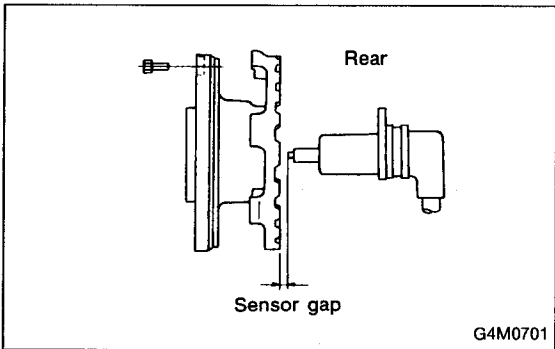
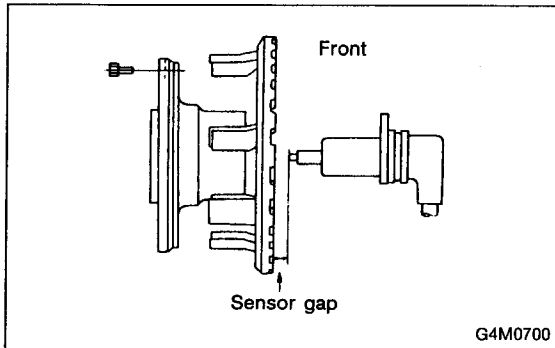

**10M7 CHECK ABS SENSOR GAP.**

Measure tone wheel to pole piece gap over entire perimeter of the wheel.

**CHECK** : Is the gap within the specifications shown in the following table?

	Front wheel	Rear wheel
Specifications	0.9 — 1.4 mm (0.035 — 0.055 in)	0.7 — 1.2 mm (0.028 — 0.047 in)

**YES** : Go to step **10M8**.

**NO** : Adjust the gap.

**NOTE:**

Adjust the gap using spacer (Part No. 26755AA000). If spacers cannot correct the gap, replace worn sensor or worn tone wheel.

**10M8 CHECK OSCILLOSCOPE.**

**CHECK** : Is an oscilloscope available?

**YES** : Go to step **10M9**.

**NO** : Go to step **10M10**.

**10M9 CHECK ABS SENSOR SIGNAL.**

- 1) Raise all four wheels of ground.
- 2) Turn ignition switch OFF.
- 3) Connect the oscilloscope to the connector (F1) or connector (B100) in accordance with trouble code.
- 4) Turn ignition switch ON.



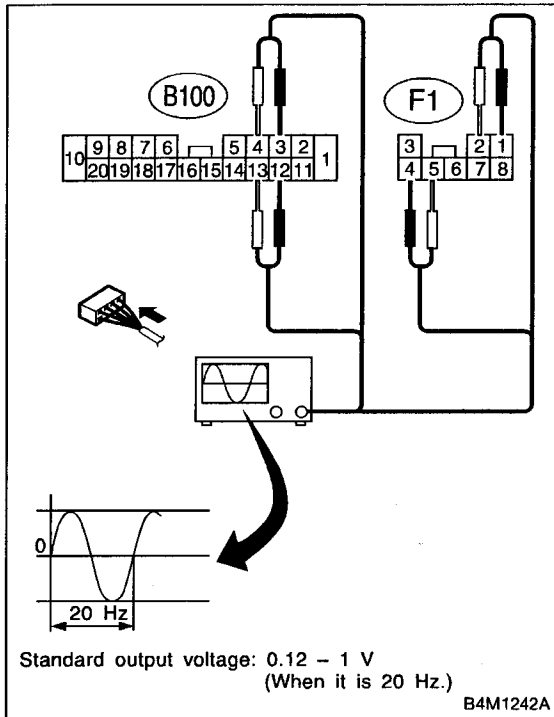

5) Rotate wheels and measure voltage at specified frequency.

NOTE:

When this inspection is completed, the ABSCM&H/U sometimes stores the trouble code 29.

**Connector & terminal**

**(B100) No. 12 (+) — No. 13 (-) (Front RH):**

**(B100) No. 3 (+) — No. 4 (-) (Front LH):**

**(F1) No. 4 (+) — No. 5 (-) (Rear RH):**

**(F1) No. 1 (+) — No. 2 (-) (Rear LH):**

**Specified voltage: 0.12 — 1 V (When it is 20 Hz.)**

**CHECK** : Is oscilloscope pattern smooth, as shown in figure?

**YES** : Go to step **8M13**.

**NO** : Go to step **8M10**.

<b>10M10</b>	<b>CHECK CONTAMINATION OF ABS SENSOR OR TONE WHEEL.</b>
--------------	---

Remove disc rotor from hub.

**CHECK** : Is the ABS sensor pole piece or the tone wheel contaminated by dirt or other foreign matter?

**YES** : Thoroughly remove dirt or other foreign matter.

**NO** : Go to step **10M11**.

<b>10M11</b>	<b>CHECK DAMAGE OF ABS SENSOR OR TONE WHEEL.</b>
--------------	--

**CHECK** : Are there broken or damaged teeth in the ABS sensor pole piece or the tone wheel?

**YES** : Replace ABS sensor or tone wheel.

**NO** : Go to step **10M12**.

<b>10M12</b>	<b>CHECK HUB RUNOUT.</b>
--------------	--------------------------

Measure hub runout.

**CHECK** : Is the runout less than 0.05 mm (0.0020 in)?

**YES** : Go to step **10M13**.

**NO** : Repair hub.

<b>10M13</b>	<b>CHECK ABSCM&amp;H/U.</b>
--------------	-----------------------------

- 1) Turn ignition switch to OFF.
- 2) Connect all connectors.
- 3) Erase the memory.
- 4) Perform inspection mode.
- 5) Read out the trouble code.

**CHECK** : *Is the same trouble code as in the current diagnosis still being output?*

**YES** : Replace ABSCM&H/U.

**NO** : Go to step **10M14**.

<b>10M14</b>	<b>CHECK ANY OTHER TROUBLE CODES APPEARANCE.</b>
--------------	--

**CHECK** : *Are other trouble codes being output?*

**YES** : Proceed with the diagnosis corresponding to the trouble code.

**NO** : A temporary poor contact.

D•NEW 31 (FB1)  
FR. EV VALVE

B4M0953

**N: TROUBLE CODE 31 FR. EV VALVE  
— ABNORMAL FRONT RH INLET SOLENOID  
VALVE —**

D•NEW 33 (FB1)  
FL. EV VALVE

B4M0954

**O: TROUBLE CODE 33 FL. EV VALVE  
— ABNORMAL FRONT LH INLET SOLENOID  
VALVE —**

D•NEW 35 (FB1)  
RR. EV VALVE

B4M0955

**P: TROUBLE CODE 35 RR. EV VALVE  
— ABNORMAL REAR RH INLET SOLENOID  
VALVE —**

D•NEW 37 (FB1)  
RL. EV VALVE

B4M0956

**Q: TROUBLE CODE 37 RL. EV VALVE  
— ABNORMAL REAR LH INLET SOLENOID  
VALVE —**

**DIAGNOSIS:**

- Faulty harness/connector
- Faulty inlet solenoid valve

**TROUBLE SYMPTOM:**

- ABS does not operate.

**WIRING DIAGRAM:**

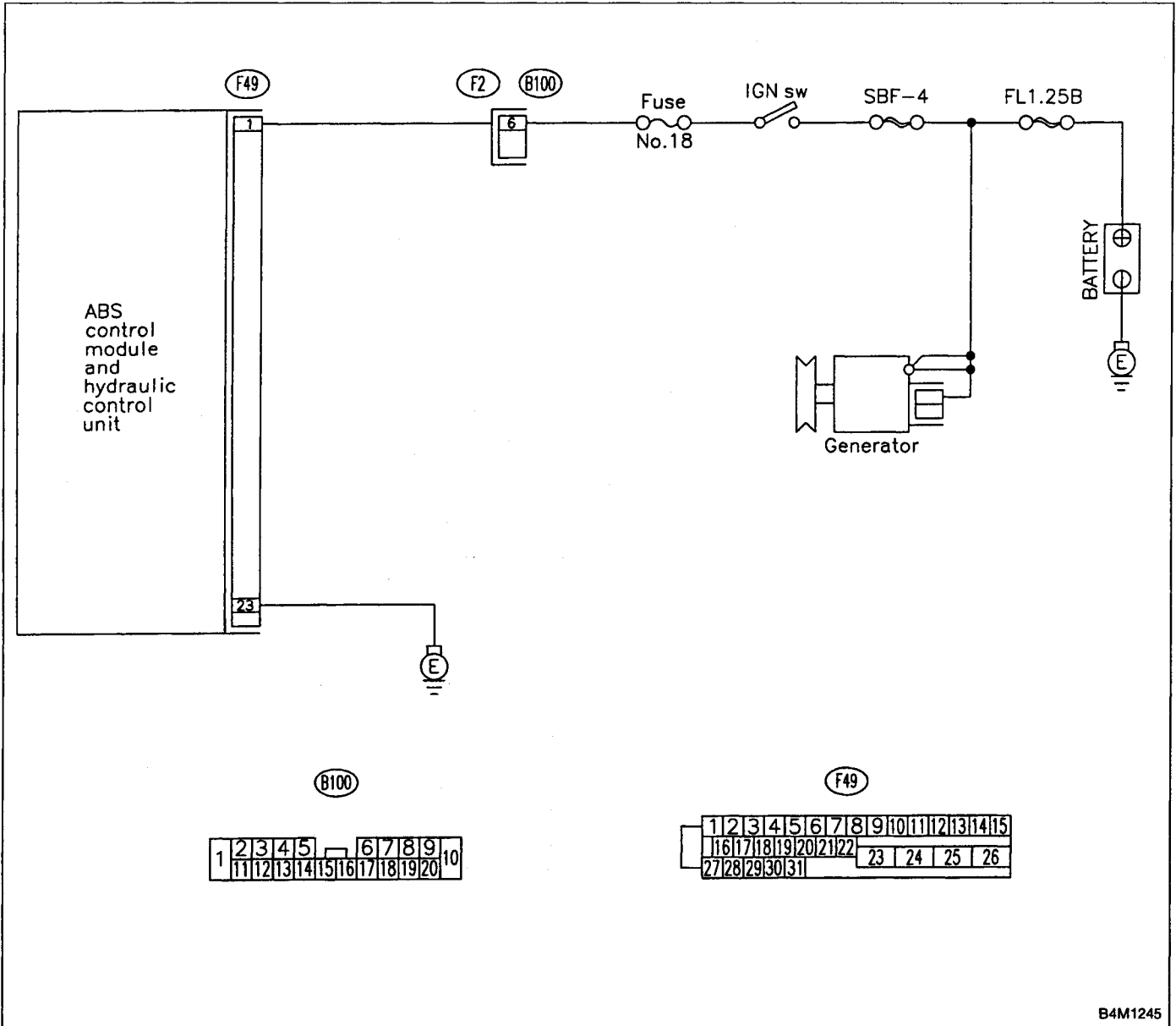

B4M1245

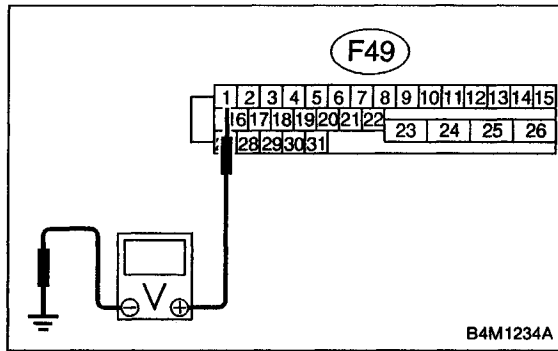

**10Q1 CHECK INPUT VOLTAGE OF ABSCM&H/U.**

- 1) Turn ignition switch to OFF.
- 2) Disconnect connector from ABSCM&H/U.
- 3) Run the engine at idle.
- 4) Measure voltage between ABSCM&H/U connector and chassis ground.

**Connector & terminal**

**(F49) No. 1 (+) — Chassis ground (-):**

**CHECK** : Is the voltage between 10 V and 15 V?

**YES** : Go to step 10Q2.

**NO** : Repair harness connector between battery, ignition switch and ABSCM&H/U.

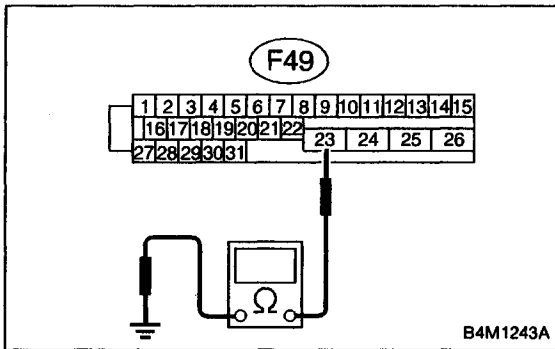

**10Q2 CHECK GROUND CIRCUIT OF ABSCM&H/U.**

- 1) Turn ignition switch to OFF.
- 2) Measure resistance between ABSCM&H/U connector and chassis ground.

**Connector & terminal**

**(F49) No. 23 — Chassis ground:**

**CHECK** : Is the resistance less than 0.5 Ω?

**YES** : Go to step 10Q3.

**NO** : Repair ABSCM&H/U ground harness.

**10Q3 CHECK POOR CONTACT IN CONNECTORS.**

**CHECK** : Is there poor contact in connectors between generator, battery and ABSCM&H/U? < Ref. to FOREWORD [T3C1].☆10 >

**YES** : Repair connector.

**NO** : Go to step 10Q4.

<b>10Q4</b>	<b>CHECK ABSCM&amp;H/U.</b>
-------------	-----------------------------

- 1) Connect all connectors.
- 2) Erase the memory.
- 3) Perform inspection mode.
- 4) Read out the trouble code.

**CHECK** : *Is the same trouble code as in the current diagnosis still being output?*

**YES** : Replace ABSCM&H/U.

**NO** : Go to step **10Q5**.

<b>10Q5</b>	<b>CHECK ANY OTHER TROUBLE CODES APPEARANCE.</b>
-------------	--

**CHECK** : *Are other trouble codes being output?*

**YES** : Proceed with the diagnosis corresponding to the trouble code.

**NO** : A temporary poor contact.

D•NEW 32 (FB1)  
FR. AV VALVE

B4M0958

**R: TROUBLE CODE 32 FR. AV VALVE  
— ABNORMAL FRONT RH OUTLET SOLENOID  
VALVE —**

D•NEW 34 (FB1)  
FL. AV VALVE

B4M0959

**S: TROUBLE CODE 34 FL. AV VALVE  
— ABNORMAL FRONT LH OUTLET SOLENOID  
VALVE —**

D•NEW 36 (FB1)  
RR. AV VALVE

B4M0960

**T: TROUBLE CODE 36 RR. AV VALVE  
— ABNORMAL REAR RH OUTLET SOLENOID  
VALVE —**

D•NEW 38 (FB1)  
RL. AV VALVE

B4M0961

**U: TROUBLE CODE 38 RL. AV VALVE  
— ABNORMAL REAR LH OUTLET SOLENOID  
VALVE —**

**DIAGNOSIS:**

- Faulty harness/connector
- Faulty outlet solenoid valve

**TROUBLE SYMPTOM:**

- ABS does not operate.

**WIRING DIAGRAM:**

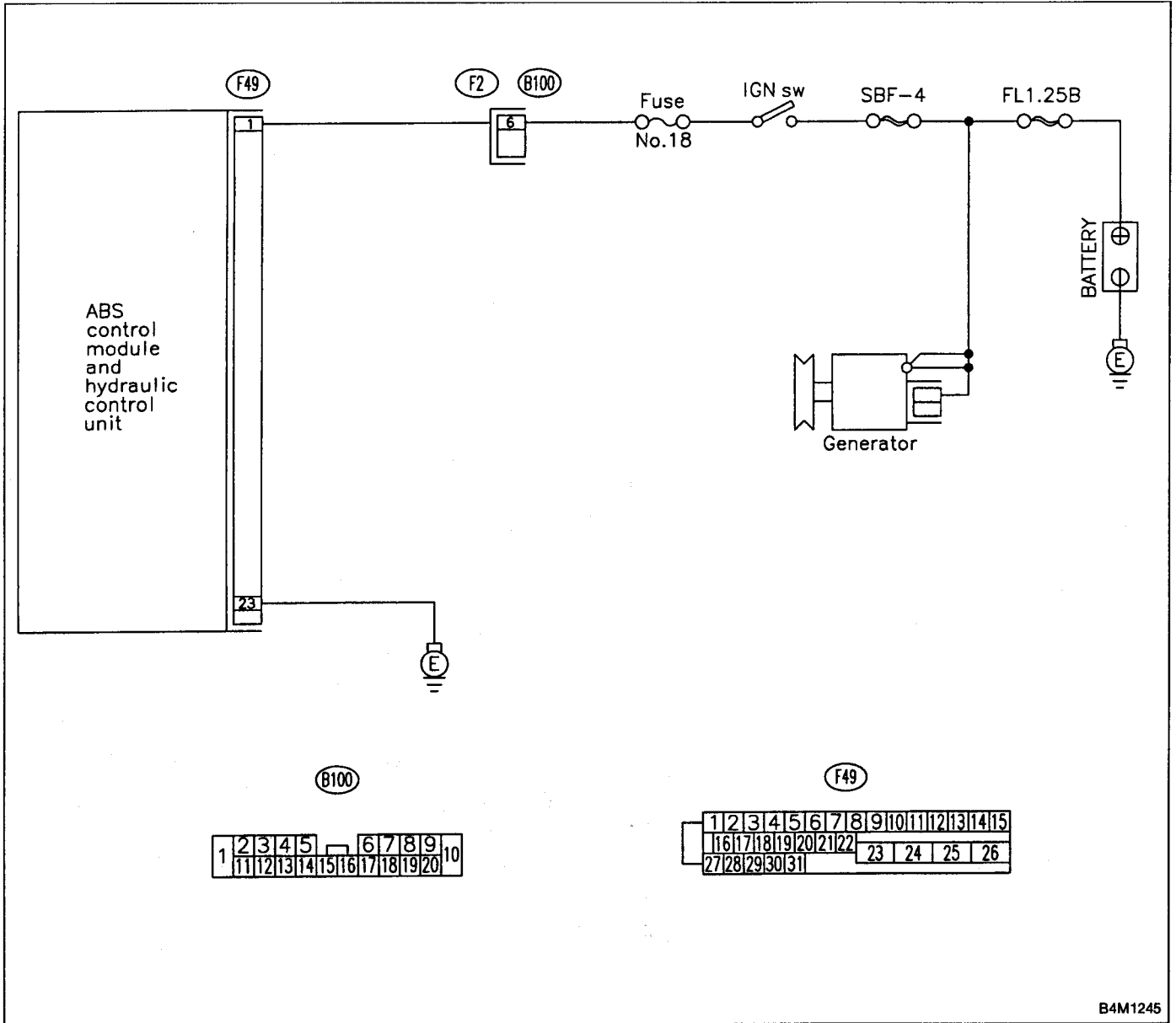

B4M1245

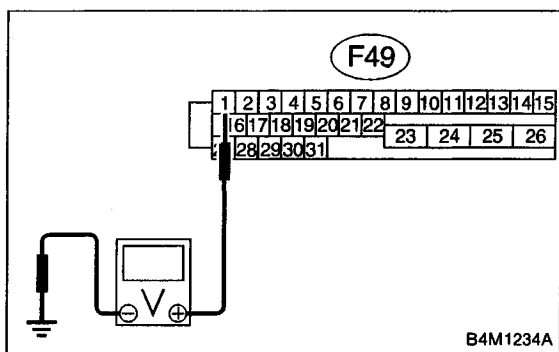

**10U1 CHECK INPUT VOLTAGE OF ABSCM&H/U.**

- 1) Turn ignition switch to OFF.
- 2) Disconnect connector from ABSCM&H/U.
- 3) Run the engine at idle.
- 4) Measure voltage between ABSCM&H/U connector and chassis ground.

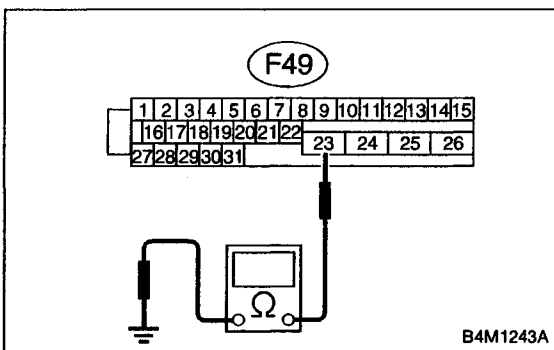
**Connector & terminal****(F49) No. 1 (+) — Chassis ground (-):****CHECK** : Is the voltage between 10 V and 15 V?**YES** : Go to step 10U2.**NO** : Repair harness connector between battery, ignition switch and ABSCM&H/U.**10U2 CHECK GROUND CIRCUIT OF ABSCM&H/U.**

- 1) Turn ignition switch to OFF.
- 2) Measure resistance between ABSCM&H/U connector and chassis ground.

**Connector & terminal****(F49) No. 23 — Chassis ground:****CHECK** : Is the resistance less than 0.5 Ω?**YES** : Go to step 10U3.**NO** : Repair ABSCM&H/U ground harness.**10U3 CHECK POOR CONTACT IN CONNECTORS.****CHECK** : Is there poor contact in connectors between generator, battery and ABSCM&H/U? < Ref. to FOREWORD [T3C1].☆10 >**YES** : Repair connector.**NO** : Go to step 10U4.

<b>10U4</b>	<b>CHECK ABSCM&amp;H/U.</b>
-------------	-----------------------------

- 1) Connect all connectors.
- 2) Erase the memory.
- 3) Perform inspection mode.
- 4) Read out the trouble code.

**CHECK** : *Is the same trouble code as in the current diagnosis still being output?*

**YES** : Replace ABSCM&H/U.

**NO** : Go to step **10U5**.

<b>10U5</b>	<b>CHECK ANY OTHER TROUBLE CODES APPEARANCE.</b>
-------------	--

**CHECK** : *Are other trouble codes being output?*

**YES** : Proceed with the diagnosis corresponding to the trouble code.

**NO** : A temporary poor contact.

D•NEW 41 (FB1)  
ECU

B4M0962

**V: TROUBLE CODE 41 ECU**  
**— ABNORMAL ABS CONTROL MODULE —**

**DIAGNOSIS:**

- Faulty ABSCM&H/U

**TROUBLE SYMPTOM:**

- ABS does not operate.

**WIRING DIAGRAM:**

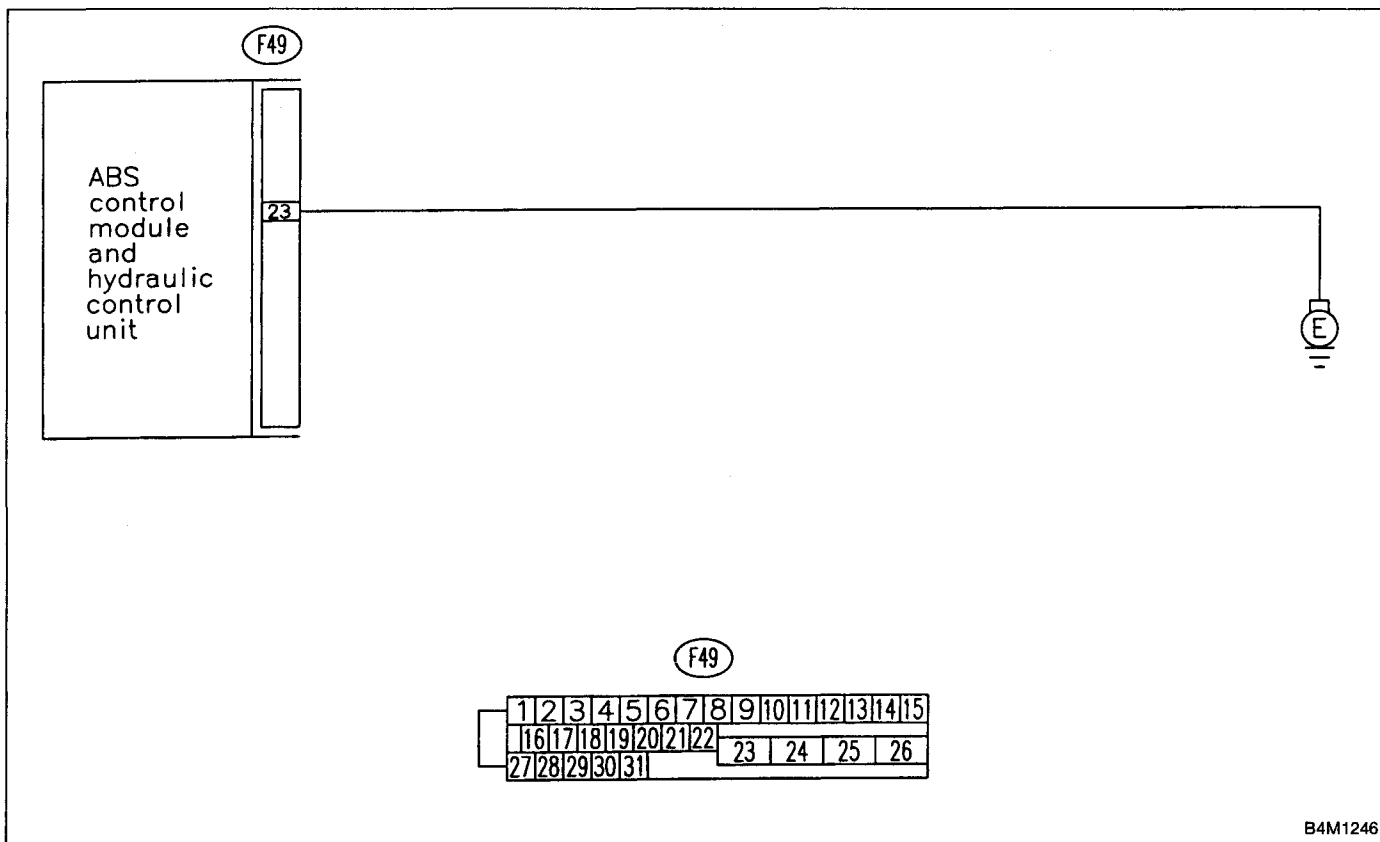

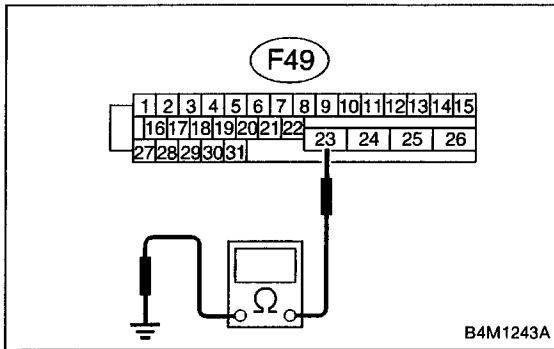

**10V1 CHECK GROUND CIRCUIT OF ABSCM&H/U.**

- 1) Turn ignition switch to OFF.
- 2) Disconnect connector from ABSCM&H/U.
- 3) Measure resistance between ABSCM&H/U and chassis ground.

**Connector & terminal**

**(F49) No. 23 — Chassis ground:**

**CHECK** : *Is the resistance less than 0.5 Ω?*

**YES** : Go to step **10V2**.

**NO** : Repair ABSCM&H/U ground harness.

**10V2 CHECK POOR CONTACT IN CONNECTORS.**

**CHECK** : *Is there poor contact in connectors between battery, ignition switch and ABSCM&H/U?*  
 <Ref. to FOREWORD [T3C1].☆10>

**YES** : Repair connector.

**NO** : Go to step **10V3**.

**10V3 CHECK SOURCES OF SIGNAL NOISE.**

**CHECK** : *Is the car telephone or the wireless transmitter properly installed?*

**YES** : Go to step **10V4**.

**NO** : Properly install the car telephone or the wireless transmitter.

**10V4 CHECK SOURCES OF SIGNAL NOISE.**

**CHECK** : *Are noise sources (such as an antenna) installed near the sensor harness?*

**YES** : Install the noise sources apart from the sensor harness.

**NO** : Go to step **10V5**.

**10V5 CHECK ABSCM&H/U.**

- 1) Turn ignition switch to OFF.
- 2) Connect all connectors.
- 3) Erase the memory.
- 4) Perform inspection mode.
- 5) Read out the trouble code.

**CHECK** : *Is the same trouble code as in the current diagnosis still being output?*

**YES** : Replace ABSCM&H/U.

**NO** : Go to step **10V6**.

10V6	<b>CHECK ANY OTHER TROUBLE CODES APPEARANCE.</b>
------	--

**CHECK**: *Are other trouble codes being output?***YES**

: Proceed with the diagnosis corresponding to the trouble code.

**NO**

: A temporary poor contact.

**D•NEW 42 (FB1)  
LOW VOLTAGE**

B4M0963

**W: TROUBLE CODE 42 LOW VOLTAGE  
— SOURCE VOLTAGE IS LOW —**

**DIAGNOSIS:**

- Power source voltage of the ABSCM&H/U is low.

**TROUBLE SYMPTOM:**

- ABS does not operate.

**WIRING DIAGRAM:**

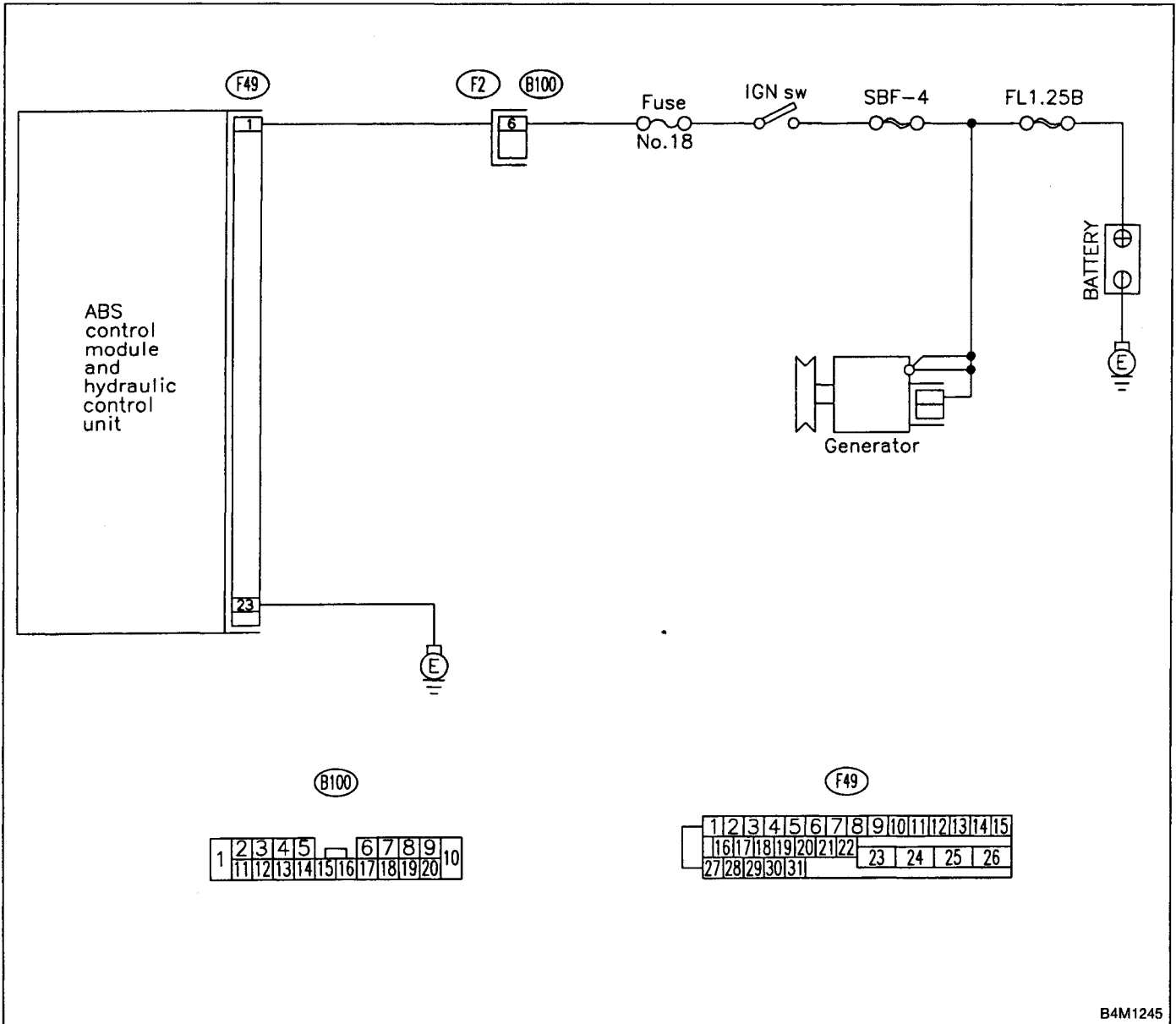

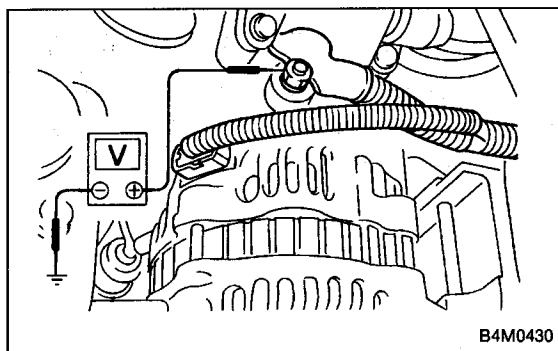

**10W1 CHECK GENERATOR.**

- 1) Start engine.
- 2) Idling after warm-up.
- 3) Measure voltage between generator B terminal and chassis ground.

**Terminal**

**Generator B terminal — Chassis ground:**

- CHECK** : Is the voltage between 10 V and 15 V?
- YES** : Go to step 10W2.
- NO** : Repair generator.

**10W2 CHECK BATTERY TERMINAL.**

Turn ignition switch to OFF.

- CHECK** : Are the positive and negative battery terminals tightly clamped?
- YES** : Go to step 10W3.
- NO** : Tighten the clamp of terminal.

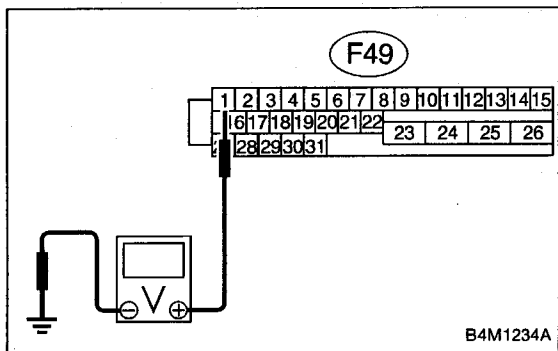

**10W3 CHECK INPUT VOLTAGE OF ABSCM&H/U.**

- 1) Disconnect connector from ABSCM&H/U.
- 2) Run the engine at idle.
- 3) Measure voltage between ABSCM&H/U connector and chassis ground.

**Connector & terminal**

**(F49) No. 1 (+) — Chassis ground (-):**

- CHECK** : Is the voltage between 10 V and 15 V?
- YES** : Go to step 10W4.
- NO** : Repair harness connector between battery, ignition switch and ABSCM&H/U.

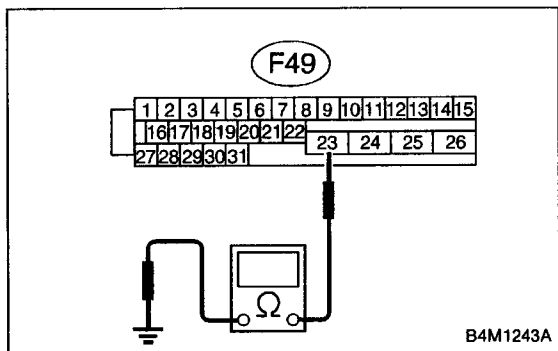

**10W4 CHECK GROUND CIRCUIT OF ABSCM&H/U.**

- 1) Turn ignition switch to OFF.
- 2) Measure resistance between ABSCM&H/U connector and chassis ground.

**Connector & terminal**

**(F49) No. 23 — Chassis ground:**

- CHECK** : Is the resistance less than 0.5 Ω?
- YES** : Go to step 10W5.
- NO** : Repair ABSCM&H/U ground harness.

<b>10W5</b>	<b>CHECK POOR CONTACT IN CONNECTORS.</b>
-------------	--

**CHECK** : *Is there poor contact in connectors between generator, battery and ABSCM&H/U? < Ref. to FOREWORD [T3C1].☆10 >*

**YES** : Repair connector.

**NO** : Go to step **10W6**.

<b>10W6</b>	<b>CHECK ABSCM&amp;H/U.</b>
-------------	-----------------------------

- 1) Connect all connectors.
- 2) Erase the memory.
- 3) Perform inspection mode.
- 4) Read out the trouble code.

**CHECK** : *Is the same trouble code as in the current diagnosis still being output?*

**YES** : Replace ABSCM&H/U.

**NO** : Go to step **10W7**.

<b>10W7</b>	<b>CHECK ANY OTHER TROUBLE CODES APPEARANCE.</b>
-------------	--

**CHECK** : *Are other trouble codes being output?*

**YES** : Proceed with the diagnosis corresponding to the trouble code.

**NO** : A temporary poor contact.



D•NEW 42 (FB1)  
HIGH VOLTAGE

B4M1268

**X: TROUBLE CODE 42 LOW VOLTAGE  
— SOURCE VOLTAGE IS HIGH —**

**DIAGNOSIS:**

- Power source voltage of the ABSCM&H/U is high.

**TROUBLE SYMPTOM:**

- ABS does not operate.

**WIRING DIAGRAM:**

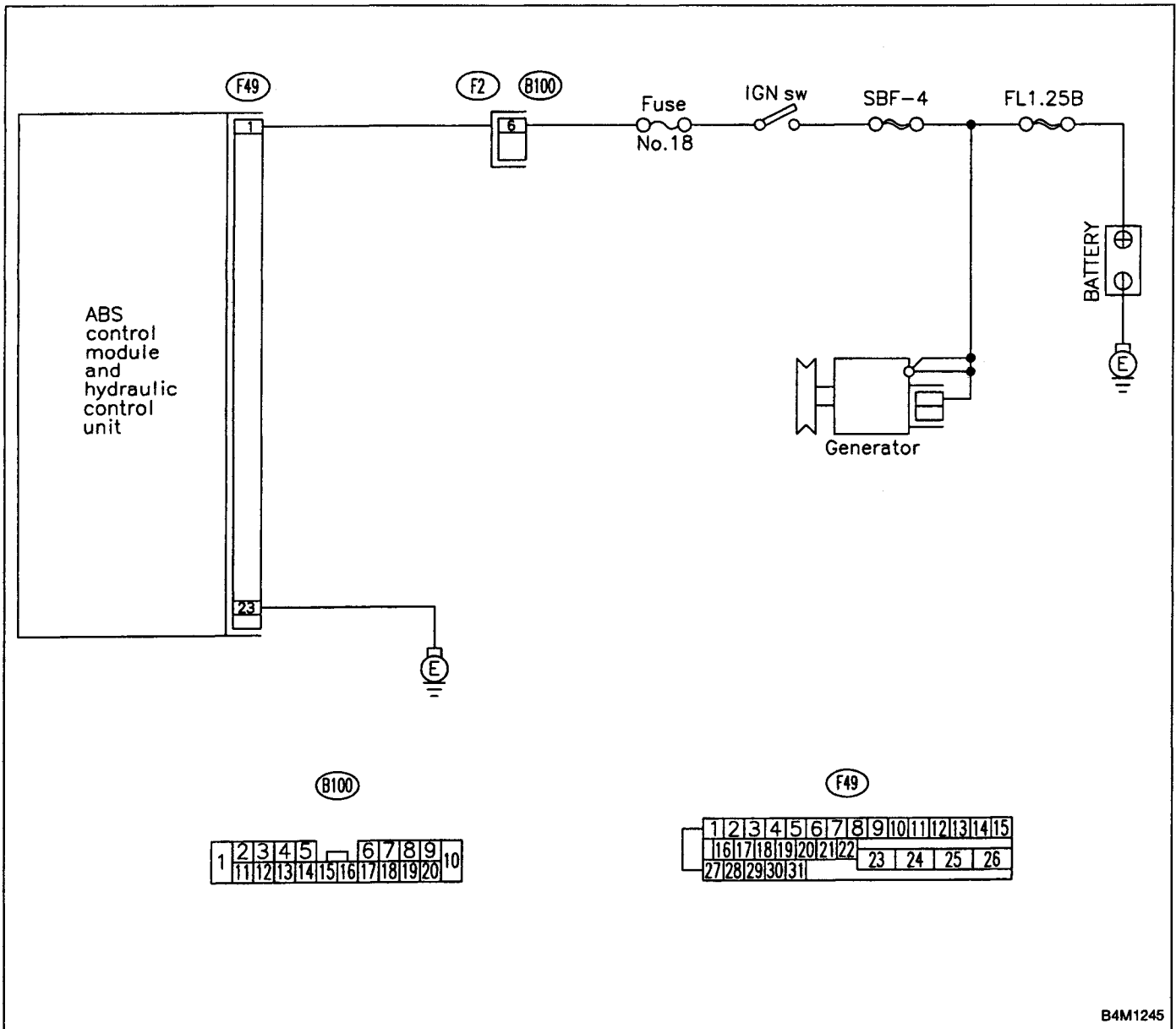

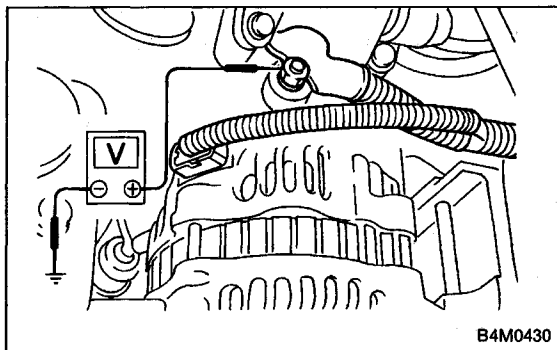

**10X1 CHECK GENERATOR.**

- 1) Start engine.
- 2) Idling after warm-up.
- 3) Measure voltage between generator B terminal and chassis ground.

**Terminal**

**Generator B terminal — Chassis ground:**

- CHECK** : Is the voltage between 10 V and 17 V?
- YES** : Go to step **10X2**.
- NO** : Repair generator.

**10X2 CHECK BATTERY TERMINAL.**

Turn ignition switch to OFF.

- CHECK** : Are the positive and negative battery terminals tightly clamped?
- YES** : Go to step **10X3**.
- NO** : Tighten the clamp of terminal.

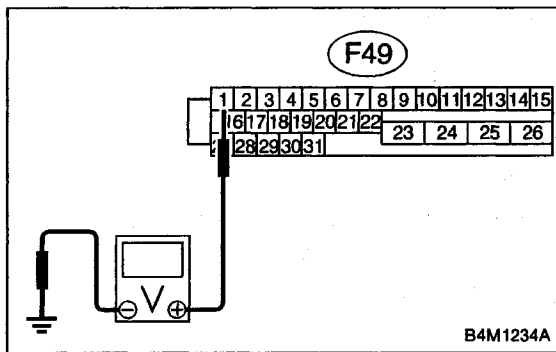

**10X3 CHECK INPUT VOLTAGE OF ABSCM&H/U.**

- 1) Disconnect connector from ABSCM&H/U.
- 2) Run the engine at idle.
- 3) Measure voltage between ABSCM&H/U connector and chassis ground.

**Connector & terminal**

**(F49) No. 1 (+) — Chassis ground (-):**

- CHECK** : Is the voltage between 10 V and 17 V?
- YES** : Go to step **10X4**.
- NO** : Repair harness connector between battery, ignition switch and ABSCM&H/U.

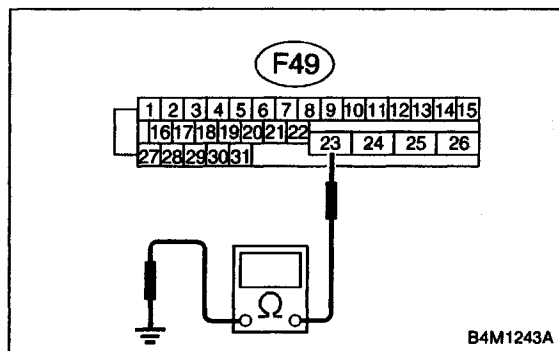
**10X4 CHECK GROUND CIRCUIT OF ABSCM&H/U.**

- 1) Turn ignition switch to OFF.
- 2) Measure resistance between ABSCM&H/U connector and chassis ground.

**Connector & terminal****(F49) No. 23 — Chassis ground:****CHECK** : Is the resistance less than 0.5 Ω?**YES** : Go to step **10X5**.**NO** : Repair ABSCM&H/U ground harness.**10X5 CHECK POOR CONTACT IN CONNECTORS.****CHECK** : Is there poor contact in connectors between generator, battery and ABSCM&HIU? < Ref. to FOREWORD [T3C1].☆10 >**YES** : Repair connector.**NO** : Go to step **10X6**.**10X6 CHECK ABSCM&H/U.**

- 1) Connect all connectors.
- 2) Erase the memory.
- 3) Perform inspection mode.
- 4) Read out the trouble code.

**CHECK** : Is the same trouble code as in the current diagnosis still being output?**YES** : Replace ABSCM&H/U.**NO** : Go to step **10X7**.**10X7 CHECK ANY OTHER TROUBLE CODES APPEARANCE.****CHECK** : Are other trouble codes being output?**YES** : Proceed with the diagnosis corresponding to the trouble code.**NO** : A temporary poor contact.

D•NEW 44 (FB1)  
CCM LINE

B4M0964

**Y: TROUBLE CODE 44 CCM LINE  
— A COMBINATION OF AT CONTROL  
ABNORMALS —**

**DIAGNOSIS:**

- Combination of AT control faults

**TROUBLE SYMPTOM:**

- ABS does not operate.

**WIRING DIAGRAM:**

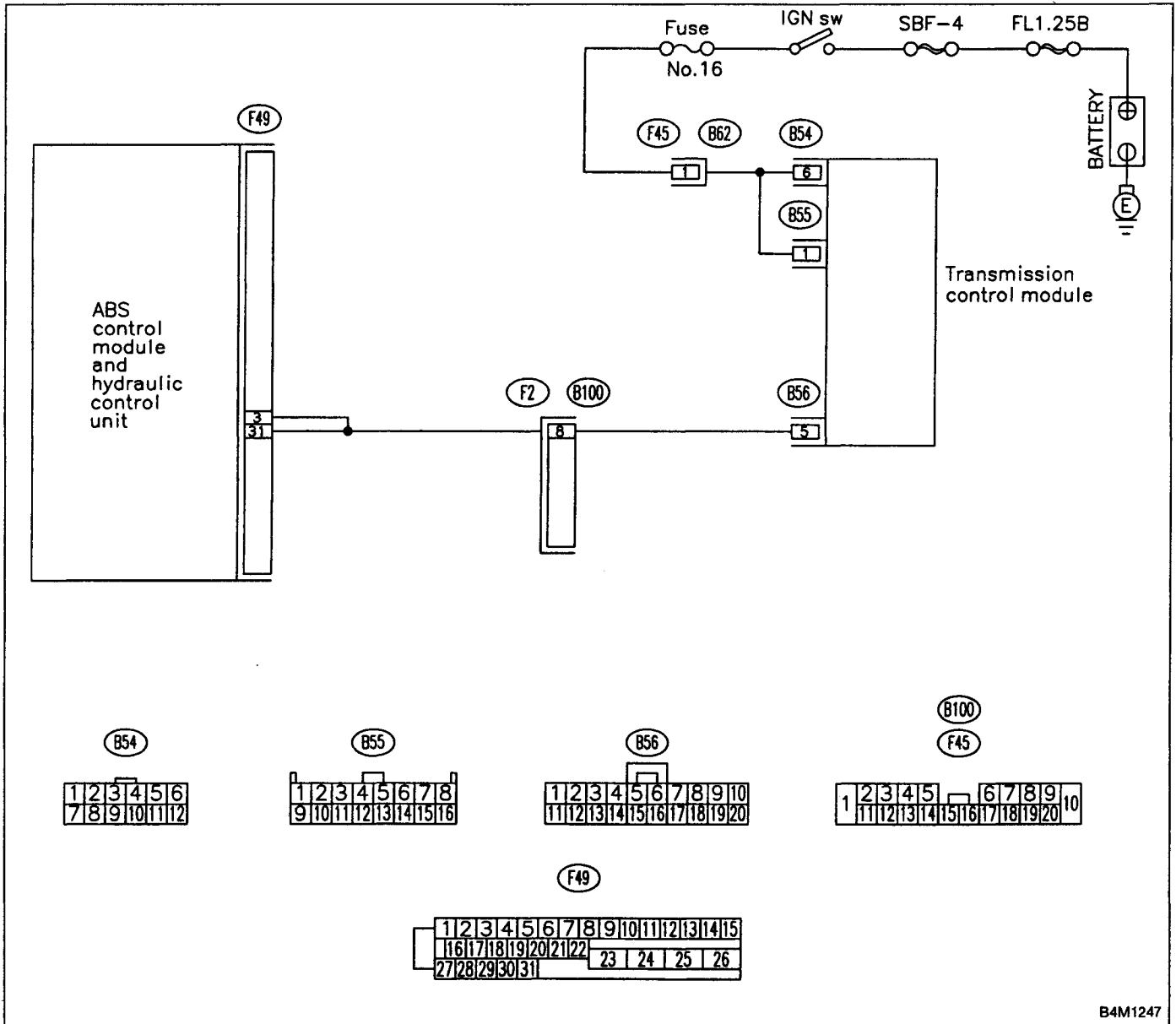

1997 (F00)  
ABS 4WD•AT

H4M1117

**10Y1 CHECK SPECIFICATIONS OF ABSCM&H/U USING SELECT MONITOR.**

- 1) Press [F], [0] and [0] on the select monitor.
- 2) Read the select monitor display.

**CHECK** : Is an ABSCM&H/U for AT model installed on a MT model?

**YES** : Replace ABSCM&H/U.

**NO** : Go to step 10Y2.

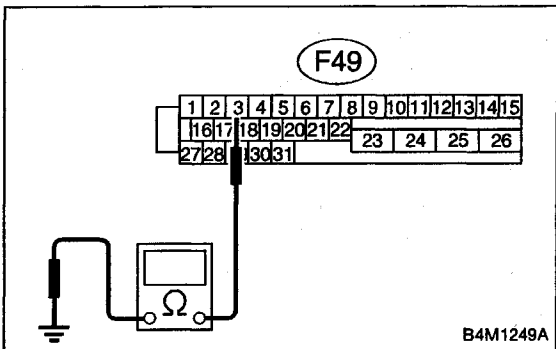

**10Y2 CHECK GROUND SHORT OF HARNESS.**

- 1) Turn ignition switch to OFF.
- 2) Disconnect two connectors from TCM.
- 3) Disconnect connector from ABSCM&H/U.
- 4) Measure resistance between ABSCM&H/U connector and chassis ground.

**Connector & terminal (F49) No. 3 — Chassis ground:**

**CHECK** : Is the resistance more than 1 MΩ?

**YES** : Go to step 10Y3.

**NO** : Repair harness between TCM and ABSCM&H/U.

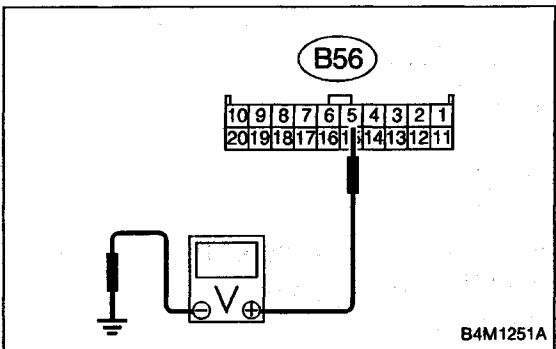

**10Y3 CHECK TCM.**

- 1) Connect all connectors to TCM.
- 2) Turn ignition switch to ON.
- 3) Measure voltage between TCM connector terminal and chassis ground.

**Connector & terminal (B55) No. 5 (+) — Chassis ground (-):**

**CHECK** : Is the voltage between 10 V and 15 V?

**YES** : Go to step 10Y5.

**NO** : Go to step 10Y4.

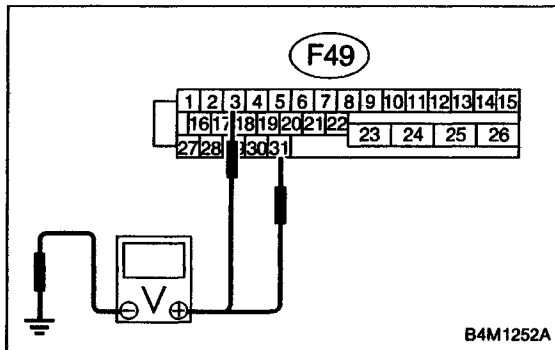
**10Y4 CHECK AT.****CHECK** : Is the AT functioning normally?**YES** : Replace TCM.**NO** : Repair AT.**10Y5 CHECK OPEN CIRCUIT OF HARNESS.**

Measure voltage between ABSCM&amp;H/U connector and chassis ground.

**Connector & terminal****(F49) No. 3 (+) — Chassis ground (-):****(F49) No. 31 (+) — Chassis ground (-):****CHECK** : Is the voltage more than 10 V?**YES** : Go to step 10Y6.**NO** : Repair harness/connector between AT control module and ABSCM&H/U.**10Y6 CHECK POOR CONTACT IN CONNECTORS.****CHECK** : Is there poor contact in connectors between AT control module and ABSCM&HIU? < Ref. to FOREWORD [T3C1].☆10 >**YES** : Repair connector.**NO** : Go to step 10Y7.**10Y7 CHECK ABSCM&H/U.**

- 1) Connect all connectors.
- 2) Erase the memory.
- 3) Perform inspection mode.
- 4) Read out the trouble code.

**CHECK** : Is the same trouble code as in the current diagnosis still being output?**YES** : Replace ABSCM&H/U.**NO** : Go to step 10Y8.**10Y8 CHECK ANY OTHER TROUBLE CODES APPEARANCE.****CHECK** : Are other trouble codes being output?**YES** : Proceed with the diagnosis corresponding to the trouble code.**NO** : A temporary poor contact.

D•NEW 44 (FB1)  
CCM OPEN

B4M0965

**Z: TROUBLE CODE 44 CCM OPEN  
— A COMBINATION OF AT CONTROL  
ABNORMALS —**

**DIAGNOSIS:**

- Combination of AT control faults

**TROUBLE SYMPTOM:**

- ABS does not operate.

**WIRING DIAGRAM:**

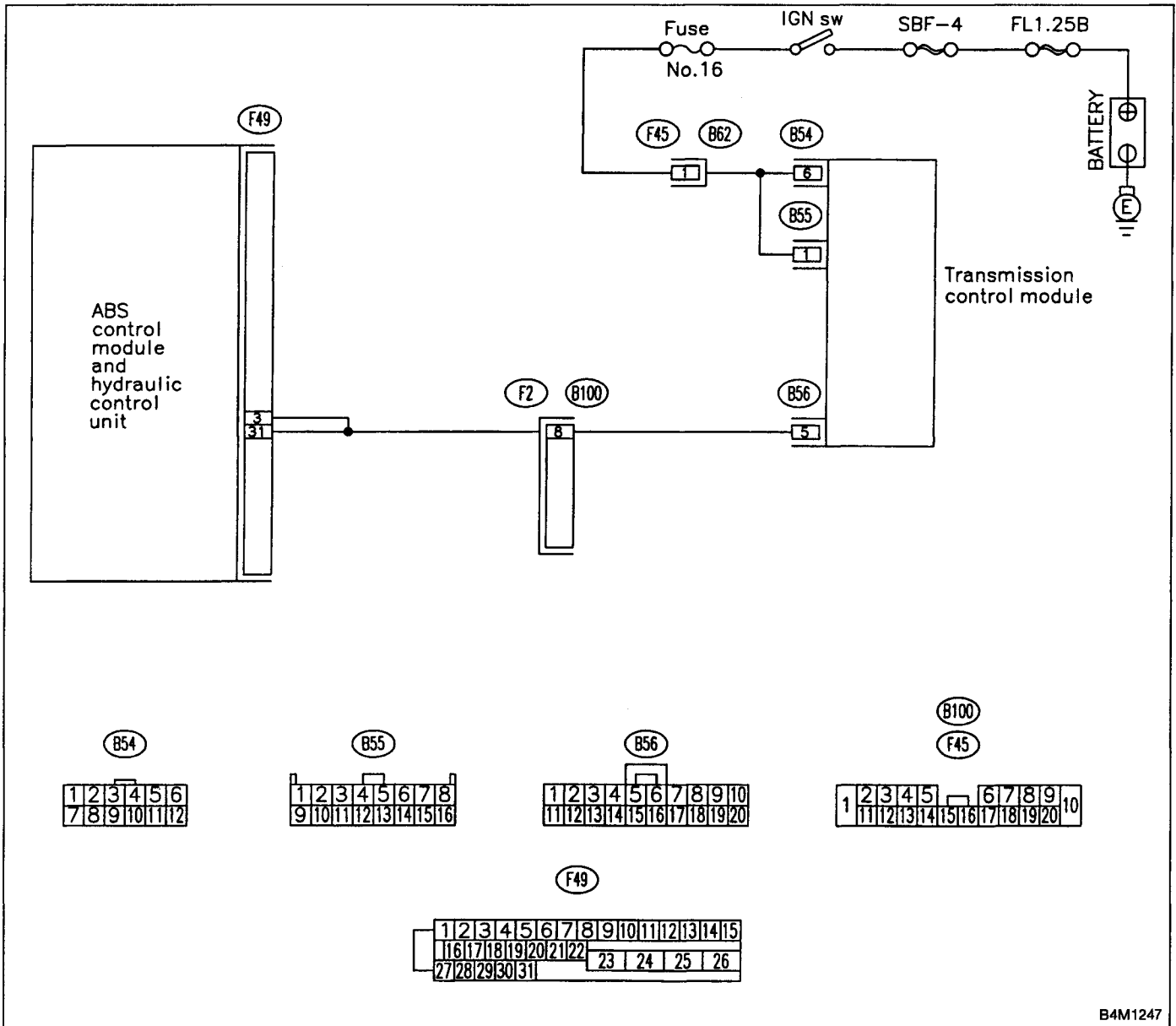

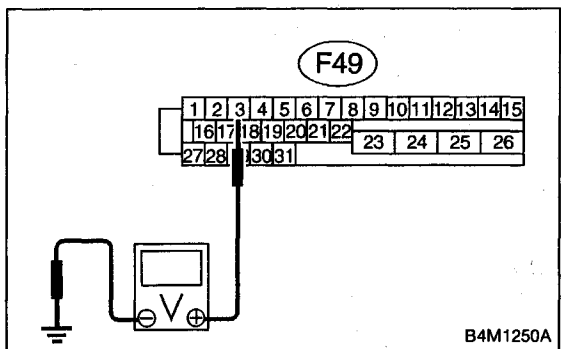

<b>10Z1</b>	<b>CHECK BATTERY SHORT OF HARNESS.</b>
-------------	--

- 1) Turn ignition switch to OFF.
- 2) Disconnect two connectors from AT control module.
- 3) Disconnect connector from ABSCM&H/U.
- 4) Measure voltage between ABSCM&H/U connector and chassis ground.

**Connector & terminal**

**(F49) No. 3 (+) — Chassis ground (-):**

- (CHECK)** : Is the voltage less than 1 V?
- (YES)** : Go to step **10Z2**.
- (NO)** : Repair harness between AT control module and ABSCM&H/U.

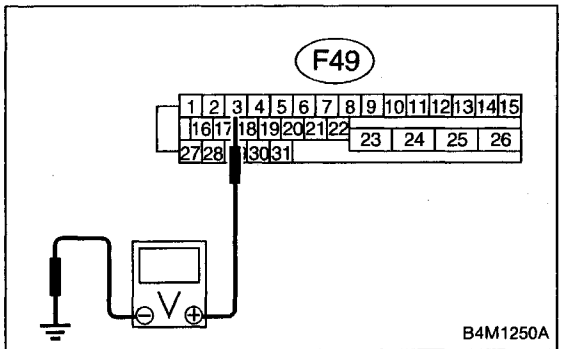

<b>10Z2</b>	<b>CHECK BATTERY SHORT OF HARNESS.</b>
-------------	--

- 1) Turn ignition switch to ON.
- 2) Measure voltage between ABSCM&H/U connector and chassis ground.

**Connector & terminal**

**(F49) No. 3 (+) — Chassis ground (-):**

- (CHECK)** : Is the voltage less than 1 V?
- (YES)** : Go to step **10Z3**.
- (NO)** : Repair harness between AT control module and ABSCM&H/U.

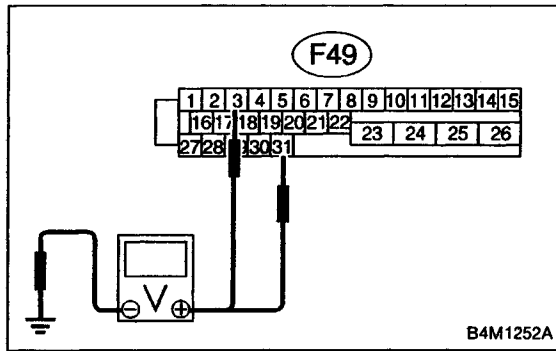

**10Z3 CHECK OPEN CIRCUIT OF HARNESS.**

- 1) Turn ignition switch to OFF.
- 2) Connect all connectors to TCM.
- 3) Turn ignition switch to ON.
- 4) Measure voltage between ABSCM&H/U connector and chassis ground.

**Connector & terminal****(F49) No. 3 (+) — Chassis ground (-):****(F49) No. 31 (+) — Chassis ground (-):****CHECK** : **Is the voltage between 10 V and 13 V?****YES** : Go to step **10Z4**.**NO** : Repair harness/connector between TCM and ABSCM&H/U.**10Z4 CHECK POOR CONTACT IN CONNECTORS.**

Turn ignition switch to OFF.

**CHECK** : **Is there poor contact in connectors between AT control module and ABSCM&H/U? < Ref. to FOREWORD [T3C1].☆10 >****YES** : Repair connector.**NO** : Go to step **10Z5**.**10Z5 CHECK ABSCM&H/U.**

- 1) Connect all connectors.
- 2) Erase the memory.
- 3) Perform inspection mode.
- 4) Read out the trouble code.

**CHECK** : **Is the same trouble code as in the current diagnosis still being output?****YES** : Replace ABSCM&H/U.**NO** : Go to step **10Z6**.**10Z6 CHECK ANY OTHER TROUBLE CODES APPEARANCE.****CHECK** : **Are other trouble codes being output?****YES** : Proceed with the diagnosis corresponding to the trouble code.**NO** : A temporary poor contact.

D•NEW 51 (FB1)  
V. RELAY

B4M0968

**AA: TROUBLE CODE 51 V. RELAY**  
**— ABNORMAL VALVE RELAY —**

**DIAGNOSIS:**

- Faulty valve relay

**TROUBLE SYMPTOM:**

- ABS does not operate.

**WIRING DIAGRAM:**

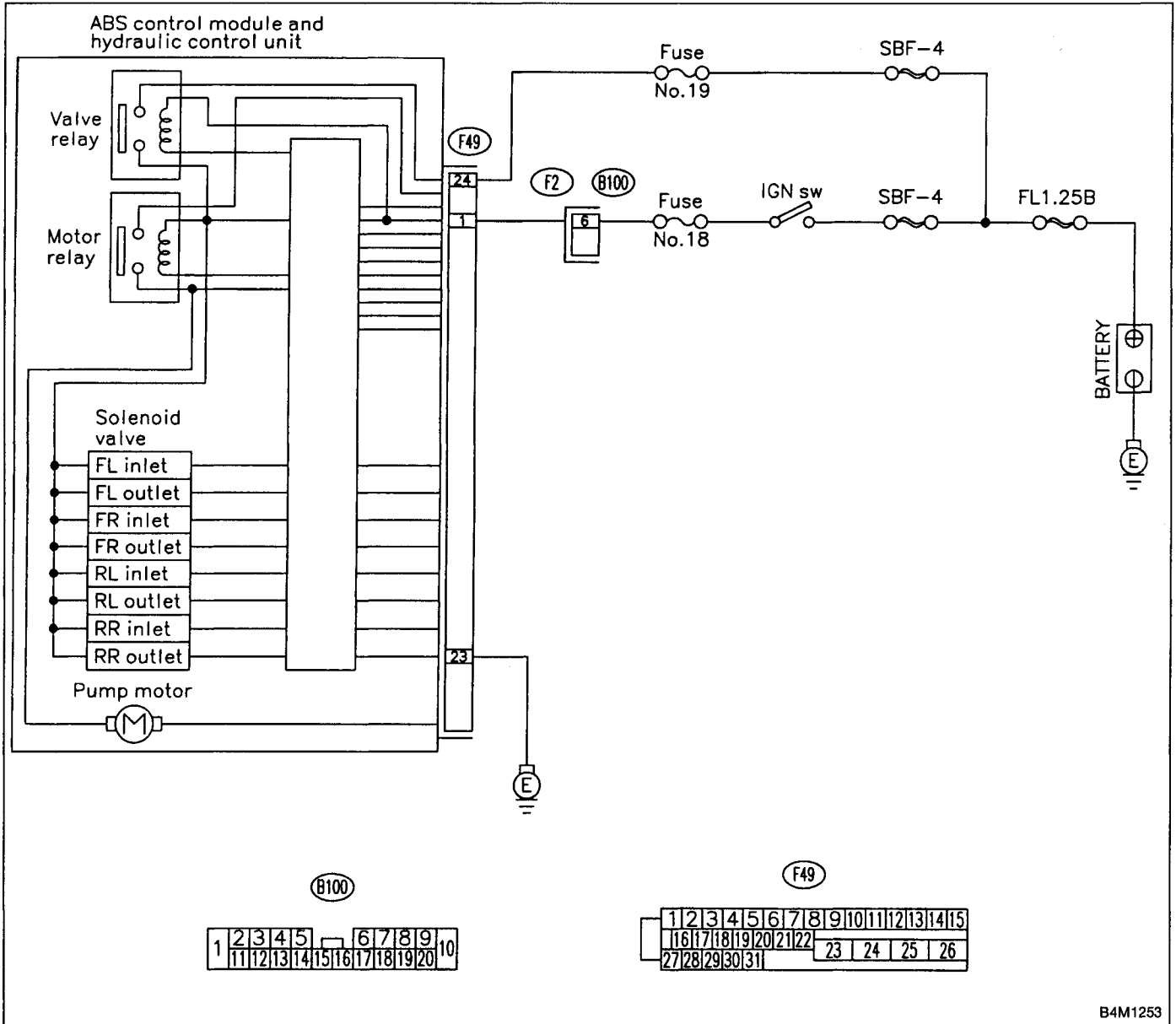

B4M1253

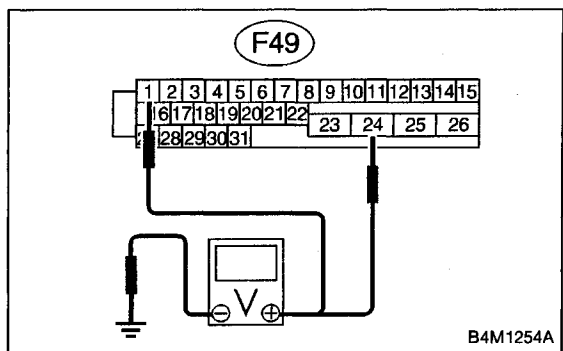

**10AA1 CHECK INPUT VOLTAGE OF ABSCM&H/U.**

- 1) Turn ignition switch to OFF.
- 2) Disconnect connector from ABSCM&H/U.
- 3) Run the engine at idle.
- 4) Measure voltage between ABSCM&H/U connector and chassis ground.

**Connector & terminal**

**(F49) No. 1 (+) — Chassis ground (-):**

**(F49) No. 24 (+) — Chassis ground (-):**

**CHECK** : Is the voltage between 10 V and 15 V?

**YES** : Go to step **10AA2**.

**NO** : Repair harness connector between battery and ABSCM&H/U.

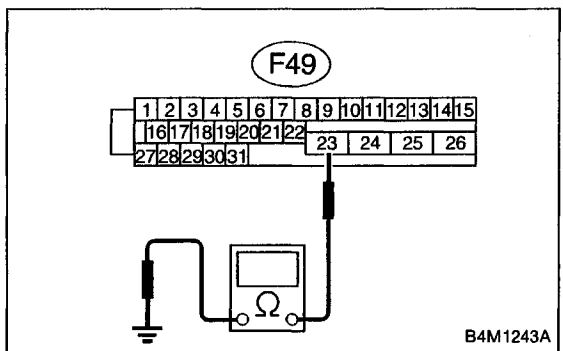

**10AA2 CHECK GROUND CIRCUIT OF ABSCM&H/U.**

- 1) Turn ignition switch to OFF.
- 2) Measure resistance between ABSCM&H/U connector and chassis ground.

**Connector & terminal**

**(F49) No. 23 — Chassis ground:**

**CHECK** : Is the resistance less than 0.5 Ω?

**YES** : Go to step **10AA3**.

**NO** : Repair ABSCM&H/U ground harness.

**10AA3 CHECK POOR CONTACT IN CONNECTORS.**

**CHECK** : Is there poor contact in connectors between generator, battery and ABSCM&H/U? < Ref. to FOREWORD [T3C1].☆10 >

**YES** : Repair connector.

**NO** : Go to step **10AA4**.

<b>10AA4</b>	<b>CHECK ABSCM&amp;H/U.</b>
--------------	-----------------------------

- 1) Connect all connectors.
- 2) Erase the memory.
- 3) Perform inspection mode.
- 4) Read out the trouble code.

**CHECK** : *Is the same trouble code as in the current diagnosis still being output?*

**YES** : Replace ABSCM&H/U.

**NO** : Go to step **10AA5**.

<b>10AA5</b>	<b>CHECK ANY OTHER TROUBLE CODES APPEARANCE.</b>
--------------	--

**CHECK** : *Are other trouble codes being output?*

**YES** : Proceed with the diagnosis corresponding to the trouble code.

**NO** : A temporary poor contact.

**D•NEW 51 (FB1)  
V. RELAY ON**

B4M0802

**AB: TROUBLE CODE 51 V. RELAY ON  
— VALVE RELAY ON FAILURE —**

**DIAGNOSIS:**

- Faulty valve relay

**TROUBLE SYMPTOM:**

- ABS does not operate.

**WIRING DIAGRAM:**

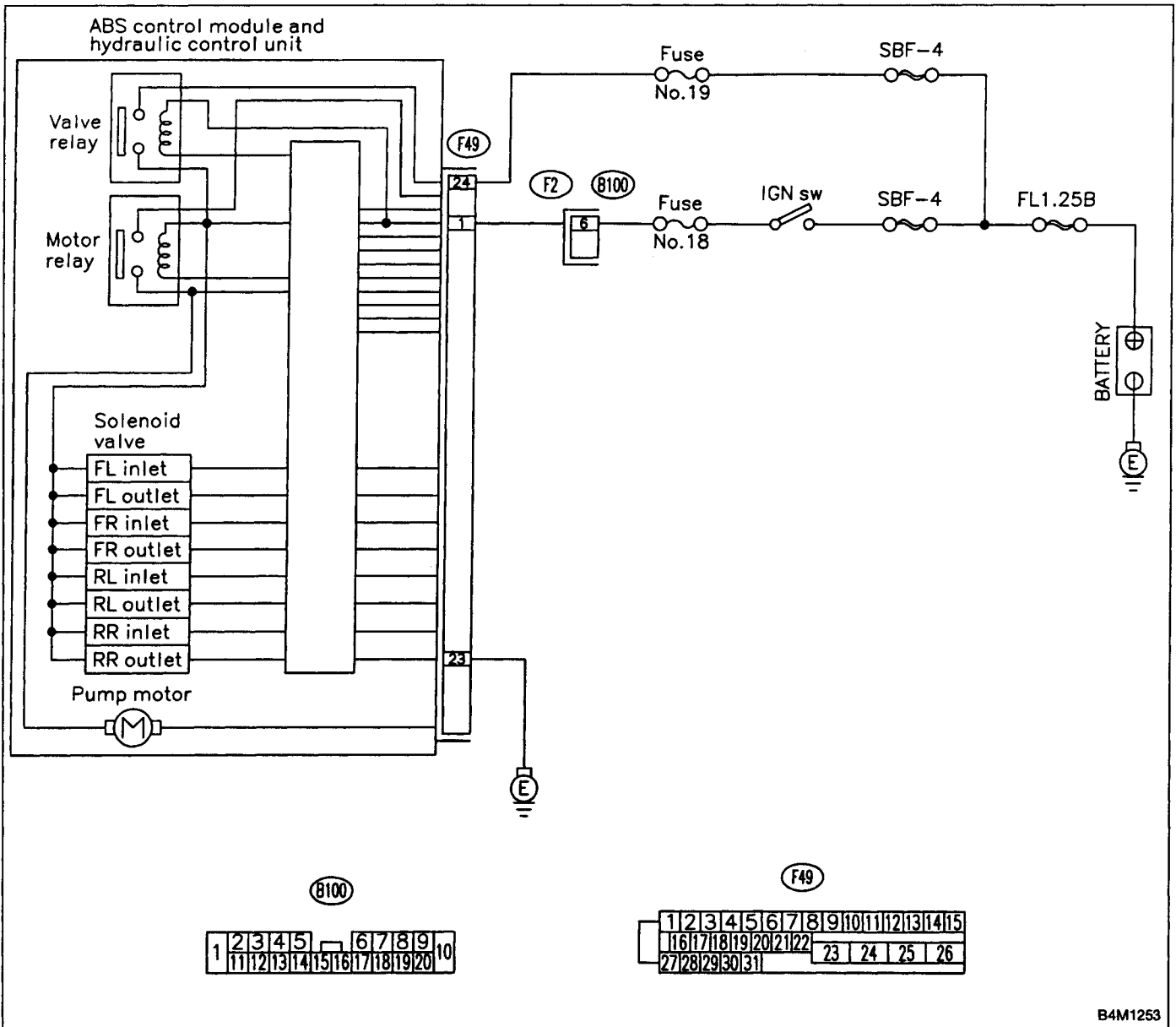

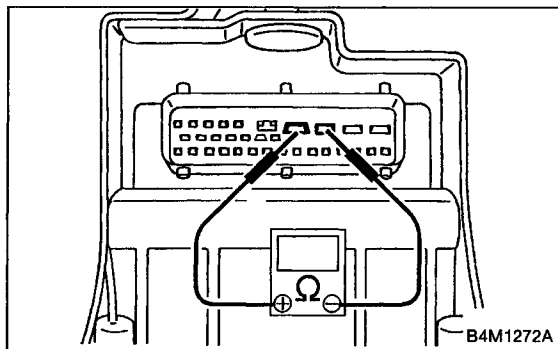
**10AB1 CHECK VALVE RELAY IN ABSCM&H/U.**

Measure resistance between ABSCM&H/U terminals.

**Terminals**

**No. 23 (+) — No. 24 (-):**

**CHECK** : Is the resistance more than 1 MΩ?

**YES** : Go to step **10AB2**.

**NO** : Replace ABSCM&H/U.

**10AB2 CHECK POOR CONTACT IN CONNECTORS.**

**CHECK** : Is there poor contact in connectors between generator, battery and ABSCM&H/U? < Ref. to FOREWORD [T3C1].☆10 >

**YES** : Repair connector.

**NO** : Go to step **10AB3**.

**10AB3 CHECK ABSCM&H/U.**

- 1) Connect all connectors.
- 2) Erase the memory.
- 3) Perform inspection mode.
- 4) Read out the trouble code.

**CHECK** : Is the same trouble code as in the current diagnosis still being output?

**YES** : Replace ABSCM&H/U.

**NO** : Go to step **10AB4**.

**10AB4 CHECK ANY OTHER TROUBLE CODES APPEARANCE.**

**CHECK** : Are other trouble codes being output?

**YES** : Proceed with the diagnosis corresponding to the trouble code.

**NO** : A temporary poor contact.

D•NEW 52 (FB1)  
M. RELAY OPEN

B4M0969

**AC: TROUBLE CODE 52 M. RELAY OPEN  
— OPEN CIRCUIT OF MOTOR RELAY —**

**DIAGNOSIS:**

- Faulty motor
- Faulty motor relay
- Faulty harness connector

**TROUBLE SYMPTOM:**

- ABS does not operate.

**WIRING DIAGRAM:**

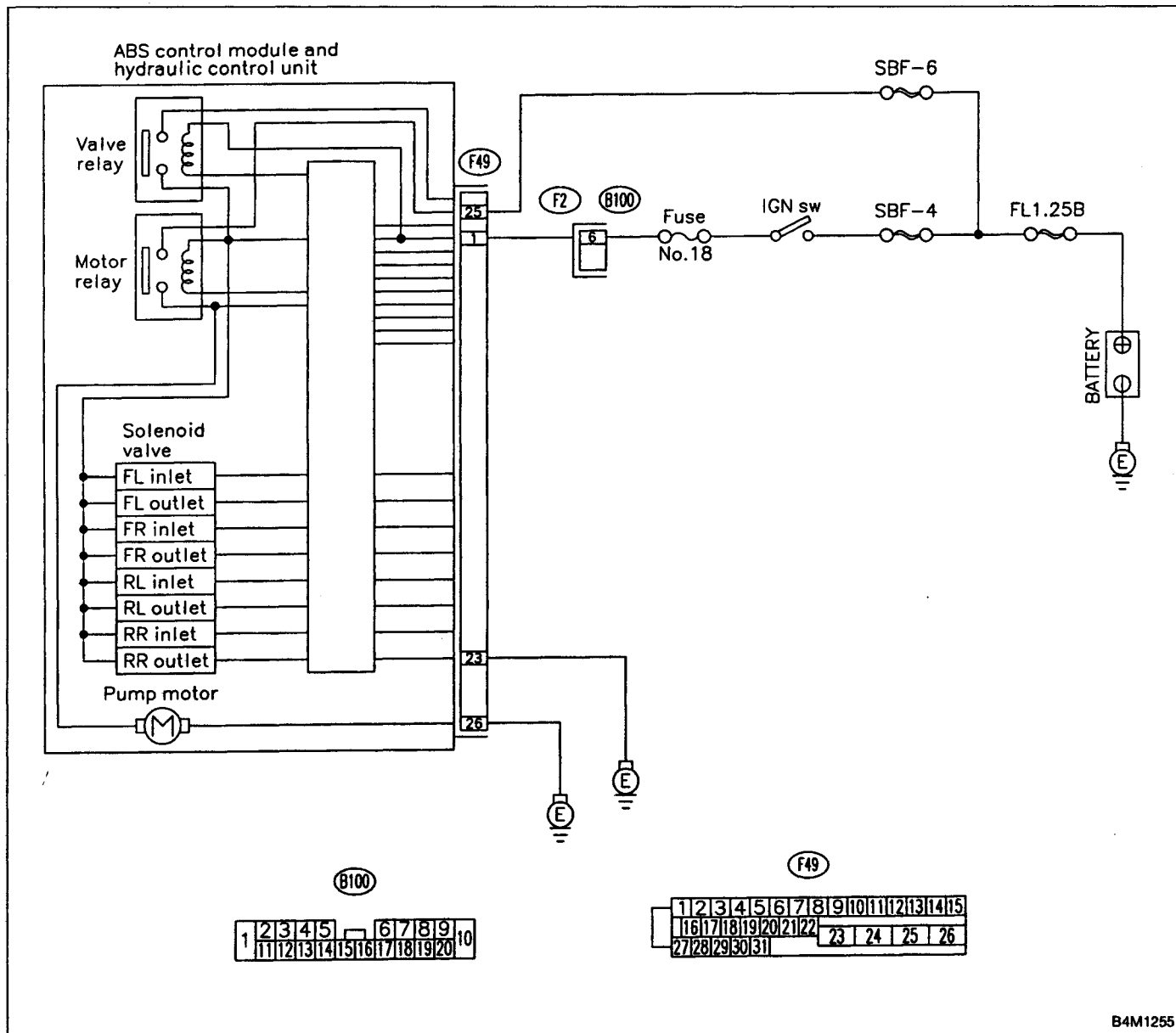

B4M1255

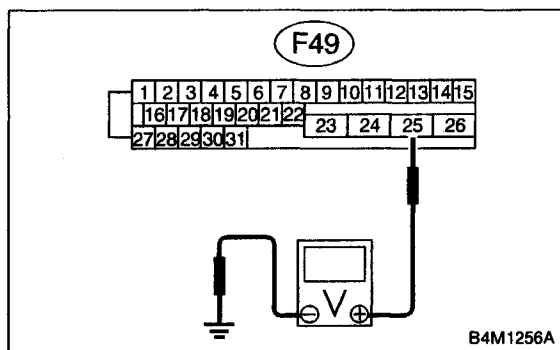
**10AC1 CHECK INPUT VOLTAGE OF ABSCM&H/U.**

- 1) Turn ignition switch to OFF.
- 2) Disconnect connector from ABSCM&H/U.
- 3) Turn ignition switch to ON.
- 4) Measure voltage between ABSCM&H/U connector and chassis ground.

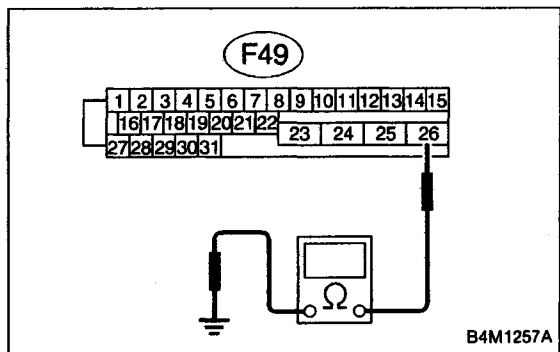
**Connector & terminal****(F49) No. 25 (+) — Chassis ground (-):****CHECK** : Is the voltage between 10 V and 13 V?**YES** : Go to step **10AC2**.**NO** : Repair harness/connector between battery and ABSCM&H/U and check fuse SBF6.**10AC2 CHECK GROUND CIRCUIT OF MOTOR.**

- 1) Turn ignition switch to OFF.
- 2) Measure resistance between ABSCM&H/U connector and chassis ground.

**Connector & terminal****(F49) No. 26 — Chassis ground:****CHECK** : Is the resistance less than 0.5 Ω?**YES** : Go to step **10AC3**.**NO** : Repair ABSCM&H/U ground harness.**10AC3 CHECK MOTOR OPERATION.**

Operate the check sequence. &lt;Ref. to 4-4 [W25D1].&gt;

**NOTE:**

Use the diagnosis connector to operate the sequence control.

**CHECK** : **Can motor revolution noise (buzz) be heard when carrying out the check sequence?****YES** : Go to step **10AC4**.**NO** : Replace ABSCM&H/U.



<b>10AC4</b>	<b>CHECK POOR CONTACT IN CONNECTORS.</b>
--------------	--

Turn ignition switch to OFF.

**CHECK** : *Is there poor contact in connector between hydraulic unit, relay box and ABSCM&H/U?*  
<Ref. to FOREWORD [T3C1].☆10 >

**YES** : Repair connector.

**NO** : Go to step **10AC5**.

<b>10AC5</b>	<b>CHECK ABSCM&amp;H/U.</b>
--------------	-----------------------------

- 1) Connect all connectors.
- 2) Erase the memory.
- 3) Perform inspection mode.
- 4) Read out the trouble code.

**CHECK** : *Is the same trouble code as in the current diagnosis still being output?*

**YES** : Replace ABSCM&H/U.

**NO** : Go to step **10AC6**.

<b>10AC6</b>	<b>CHECK ANY OTHER TROUBLE CODES APPEARANCE.</b>
--------------	--

**CHECK** : *Are other trouble codes being output?*

**YES** : Proceed with the diagnosis corresponding to the trouble code.

**NO** : A temporary poor contact.

D•NEW 52 (FB1)  
M. RELAY ON

B4M0970

**AD: TROUBLE CODE 52 M. RELAY ON  
— MOTOR RELAY ON FAILURE —**

**DIAGNOSIS:**

- Faulty motor
- Faulty motor relay
- Faulty harness connector

**TROUBLE SYMPTOM:**

- ABS does not operate.

**WIRING DIAGRAM:**

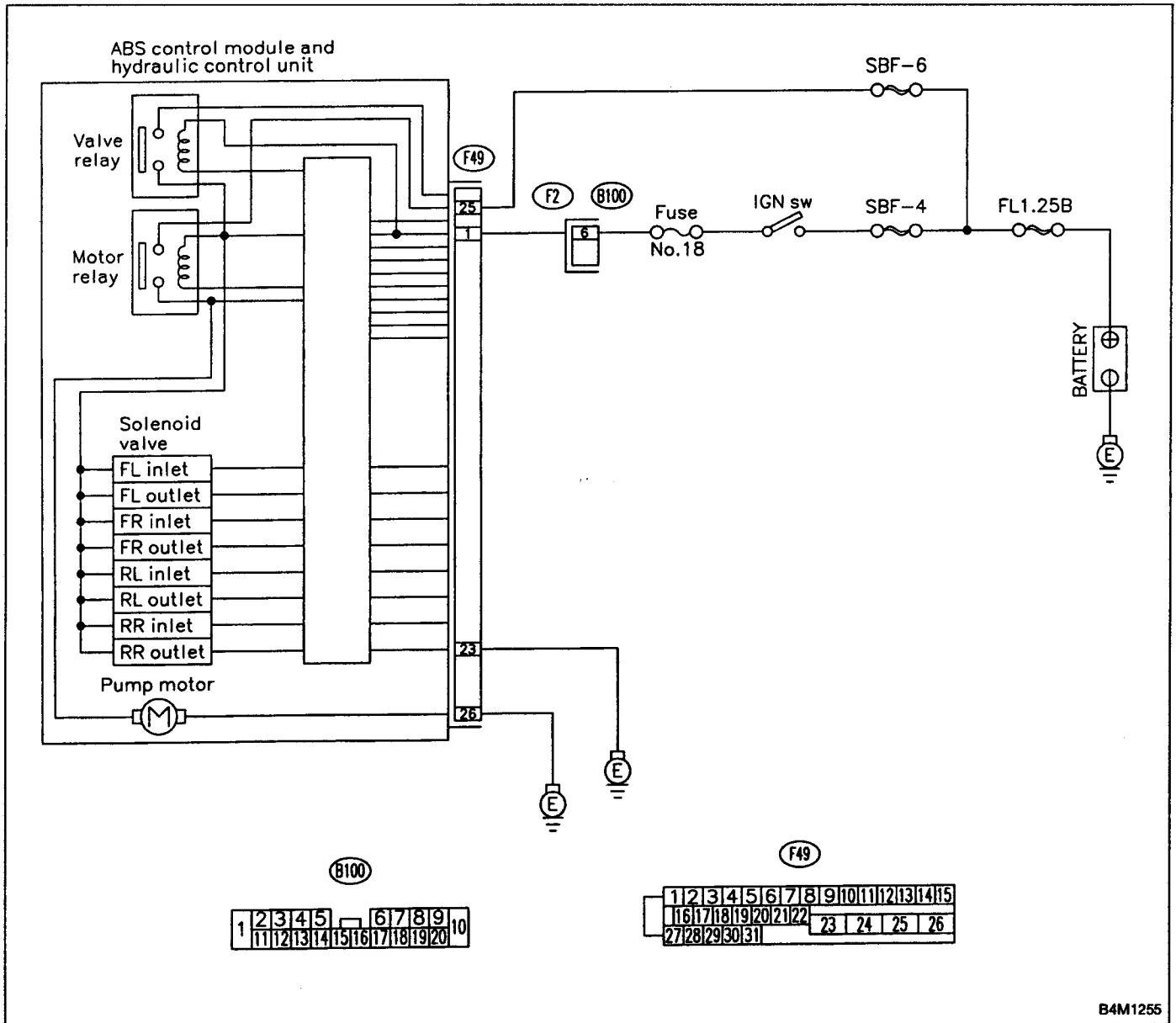

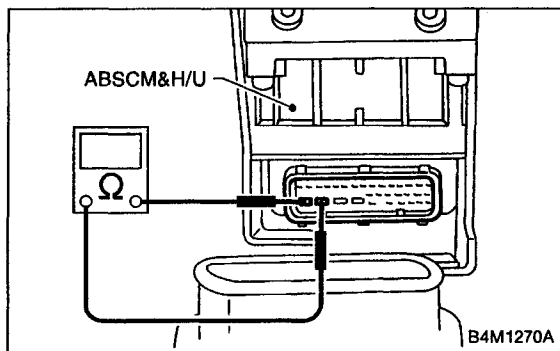

**10AD1 CHECK MOTOR RELAY IN ABSCM&H/U.**

Measure resistance between ABSCM&H/U terminals.

**Terminals**

**No. 25 — No. 26:**

- CHECK** : *Is the resistance more than 1 MΩ?*
- YES** : Go to step **10AD2**.
- NO** : Replace ABSCM&H/U.

**10AD2 CHECK MOTOR OPERATION.**

Operate the sequence control. < Ref. to 4-4 [W25D1]. >

- CHECK** : *Can motor revolution noise (buzz) be heard when carrying out the sequence control?*
- YES** : Go to step **10AD3**.
- NO** : Replace ABSCM&H/U.

**10AD3 CHECK POOR CONTACT IN CONNECTORS.**

Turn ignition switch to OFF.

- CHECK** : *Is there poor contact in connector between hydraulic unit, relay box and ABSCM&HIU? < Ref. to FOREWORD [T3C1].☆10 >*
- YES** : Repair connector.
- NO** : Go to step **10AD4**.

**10AD4 CHECK ABSCM&H/U.**

- 1) Connect all connectors.
- 2) Erase the memory.
- 3) Perform inspection mode.
- 4) Read out the trouble code.

- CHECK** : *Is the same trouble code as in the current diagnosis still being output?*
- YES** : Replace ABSCM&H/U.
- NO** : Go to step **10AD5**.

**10AD5 CHECK ANY OTHER TROUBLE CODES APPEARANCE.**

- CHECK** : *Are other trouble codes being output?*
- YES** : Proceed with the diagnosis corresponding to the trouble code.
- NO** : A temporary poor contact.

**D•NEW 52 (FB1)  
MOTOR**

B4M0971

**AE: TROUBLE CODE 52 MOTOR  
— ABNORMAL MOTOR —**

**DIAGNOSIS:**

- Faulty motor
- Faulty motor relay
- Faulty harness connector

**TROUBLE SYMPTOM:**

- ABS does not operate.

**WIRING DIAGRAM:**

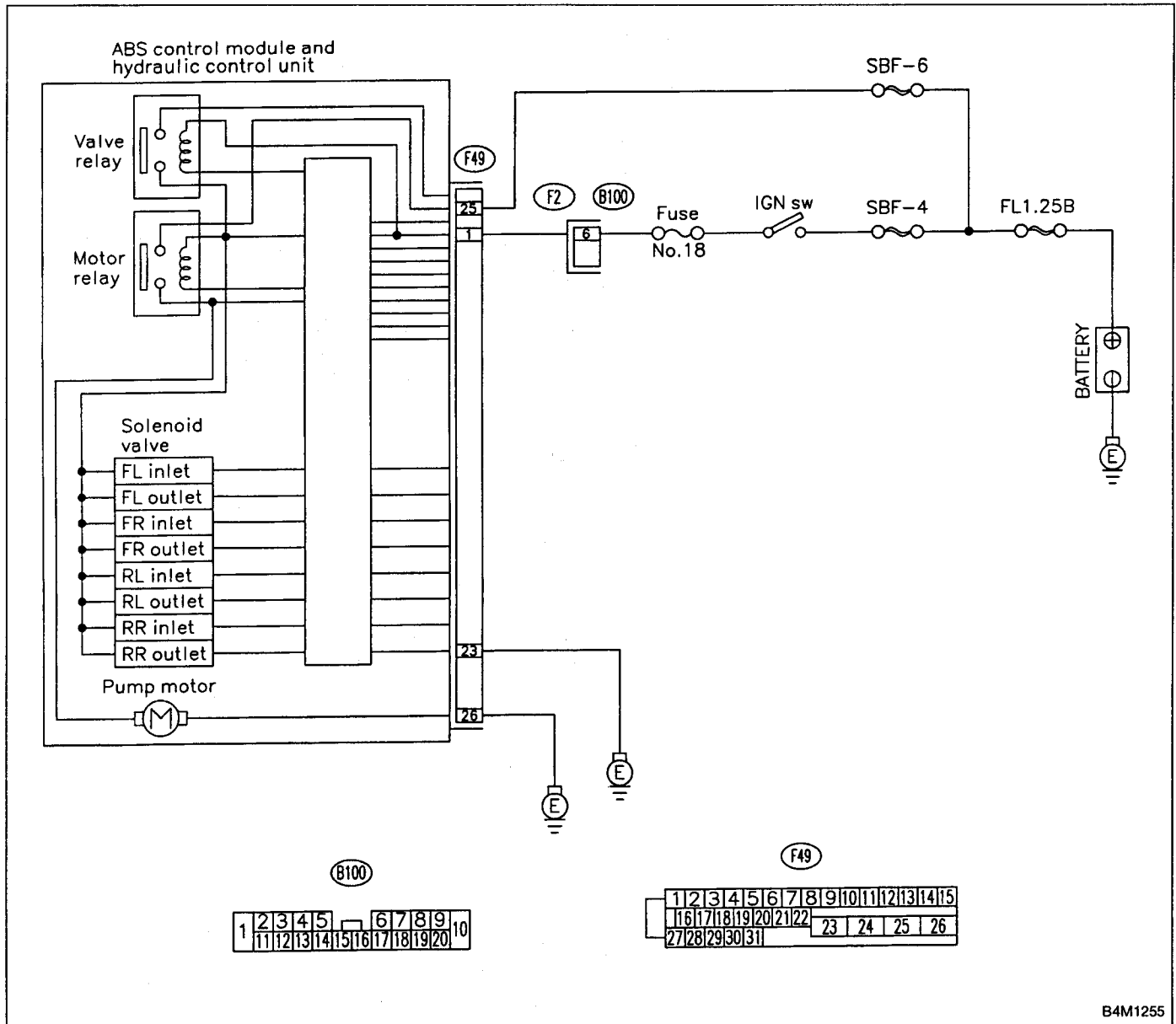

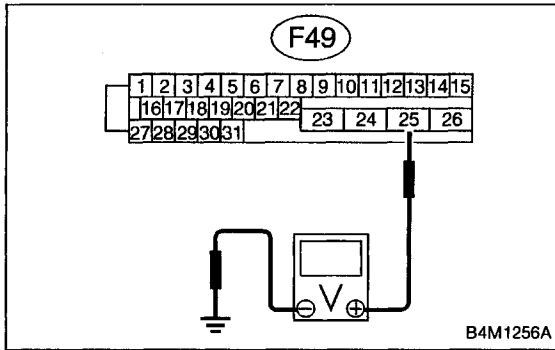

**10AE1 CHECK INPUT VOLTAGE OF ABSCM&H/U.**

- 1) Turn ignition switch to OFF.
- 2) Disconnect connector from ABSCM&H/U.
- 3) Turn ignition switch to ON.
- 4) Measure voltage between ABSCM&H/U connector and chassis ground.

**Connector & terminal**

**(F49) No. 25 (+) — Chassis ground (-):**

**CHECK** : Is the voltage between 10 V and 13 V?

**YES** : Go to step 10AE2.

**NO** : Repair harness/connector between battery and ABSCM&H/U and check fuse SBF6.

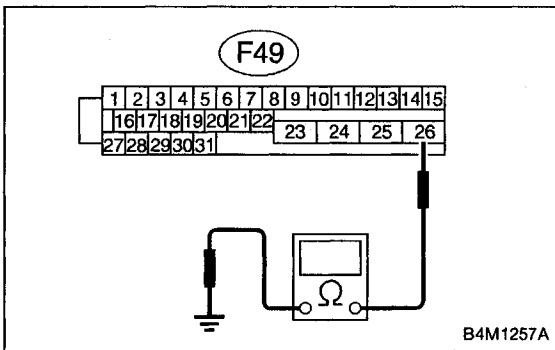

**10AE2 CHECK GROUND CIRCUIT OF MOTOR.**

- 1) Turn ignition switch to OFF.
- 2) Measure resistance between ABSCM&H/U connector and chassis ground.

**Connector & terminal**

**(F49) No. 26 — Chassis ground:**

**CHECK** : Is the resistance less than 0.5 Ω?

**YES** : Go to step 10AE3.

**NO** : Repair ABSCM&H/U ground harness.

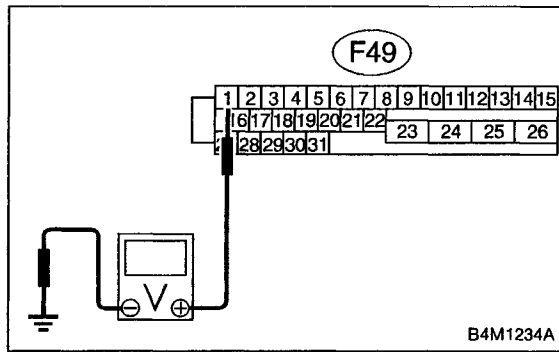

**10AE3 CHECK INPUT VOLTAGE OF ABSCM&H/U.**

- 1) Run the engine at idle.
- 2) Measure voltage between ABSCM&H/U connector and chassis ground.

**Connector & terminal**

**(F49) No. 1 (+) — Chassis ground (-):**

**CHECK** : Is the voltage between 10 V and 15 V?

**YES** : Go to step 10AE4.

**NO** : Repair harness connector between battery, ignition switch and ABSCM&H/U.

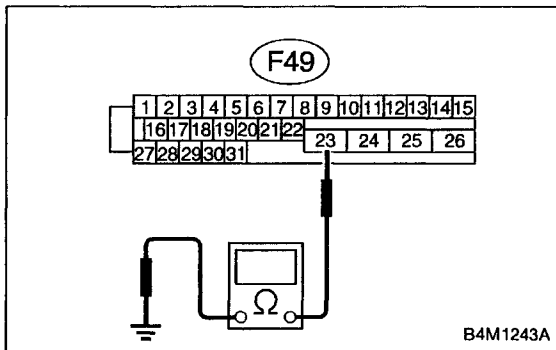

**10AE4 CHECK GROUND CIRCUIT OF ABSCM&H/U.**

- 1) Turn ignition switch to OFF.
- 2) Measure resistance between ABSCM&H/U connector and chassis ground.

**Connector & terminal**

**(F49) No. 23 — Chassis ground:**

**CHECK** : Is the resistance less than 0.5 Ω?

**YES** : Go to step 10AE5.

**NO** : Repair ABSCM&H/U ground harness.

**10AE5 CHECK MOTOR OPERATION.**

Operate the sequence control. <Ref. to 4-4 [W25D1].>

NOTE:

Use the diagnosis connector to operate the sequence control.

**CHECK** : Can motor revolution noise (buzz) be heard when carrying out the sequence control?

**YES** : Go to step 10AE6.

**NO** : Replace hydraulic unit.

**10AE6 CHECK POOR CONTACT IN CONNECTORS.**

Turn ignition switch to OFF.

**CHECK** : *Is there poor contact in connector between generator, battery and ABSCM&HIU? <Ref. to FOREWORD [T3C1].☆10>*

**YES** : Repair connector.

**NO** : Go to step **10AE7**.

**10AE7 CHECK ABSCM&H/U.**

- 1) Connect all connectors.
- 2) Erase the memory.
- 3) Perform inspection mode.
- 4) Read out the trouble code.

**CHECK** : *Is the same trouble code as in the current diagnosis still being output?*

**YES** : Replace ABSCM&H/U.

**NO** : Go to step **10AE8**.

**10AE8 CHECK ANY OTHER TROUBLE CODES APPEARANCE.**

**CHECK** : *Are other trouble codes being output?*

**YES** : Proceed with the diagnosis corresponding to the trouble code.

**NO** : A temporary poor contact.

D•NEW 54 (FB1)  
BLS

B4M0972

**AF: TROUBLE CODE 54 BLS**  
**— ABNORMAL STOP LIGHT SWITCH —**

**DIAGNOSIS:**

- Faulty stop light switch

**TROUBLE SYMPTOM:**

- ABS does not operate.

**WIRING DIAGRAM:**

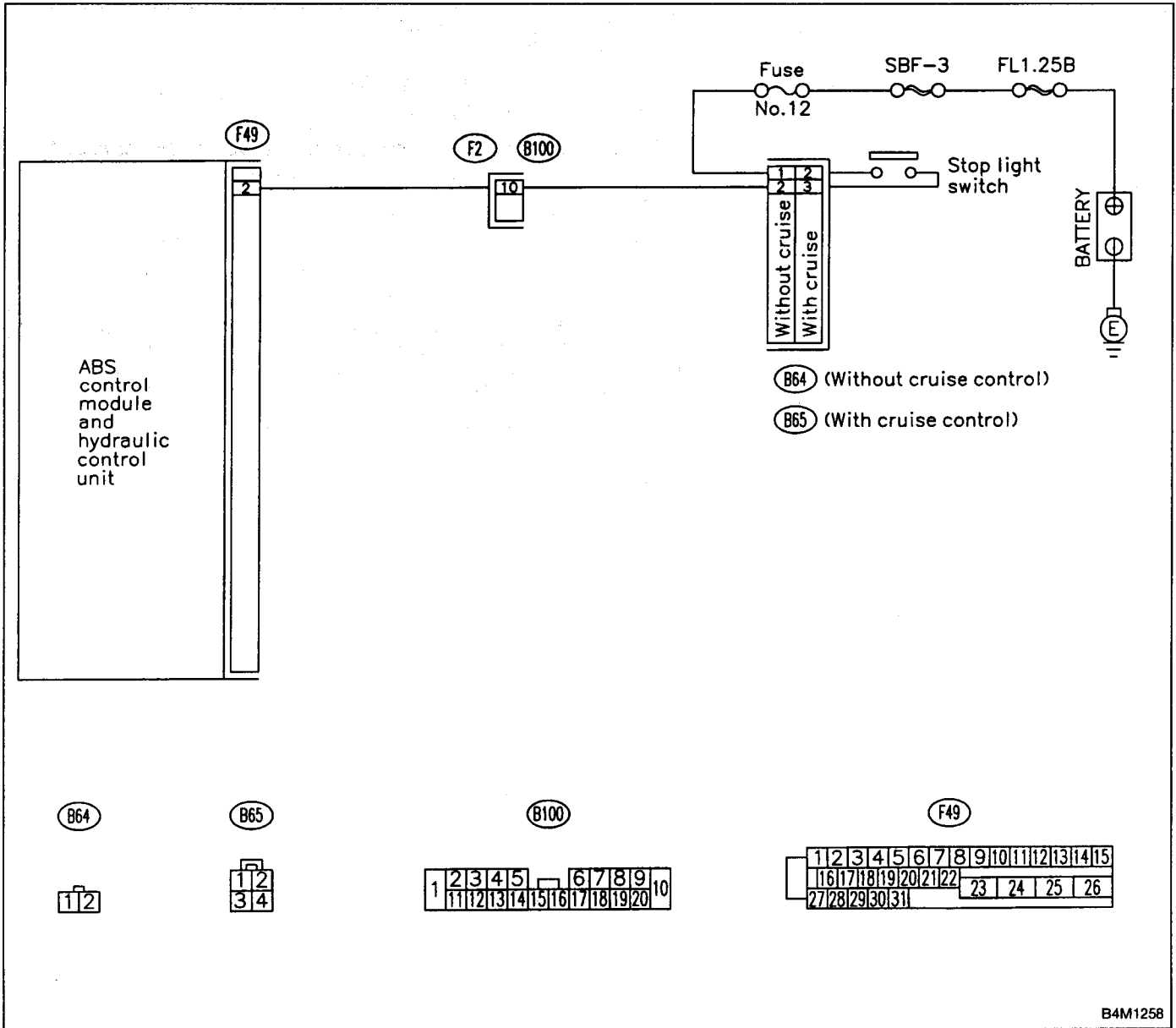



BLS (F09)  
0.00 V

B4M0973

**10AF1****CHECK OUTPUT OF STOP LIGHT SWITCH USING SELECT MONITOR.**

- 1) Press [F], [0] and [9] on the select monitor.
- 2) Depress the brake pedal.
- 3) Read the stop light switch output on the select monitor display.

**CHECK** : *Is the reading indicated on monitor display less than 1.5 V?*

**YES** : Go to step **10AF2**.

**NO** : Go to step **10AF3**.

BLS (F09)  
12.00 V

B4M1265

**10AF2****CHECK OUTPUT OF STOP LIGHT SWITCH USING SELECT MONITOR.**

- 1) Release the brake pedal.
- 2) Read the stop light switch output on the select monitor display.

**CHECK** : *Is the reading indicated on monitor display between 10 V and 15 V?*

**YES** : Go to step **10AF5**.

**NO** : Go to step **10AF3**.

**10AF3****CHECK IF STOP LIGHTS COME ON.**

Depress the brake pedal.

**CHECK** : *Do stop lights turn on?*

**YES** : Go to step **10AF4**.

**NO** : Repair stop lights circuit.

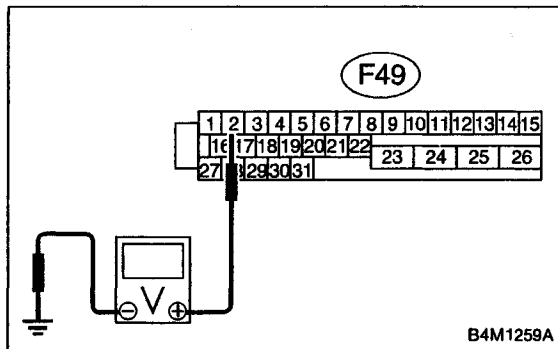

**10AF4 CHECK OPEN CIRCUIT IN HARNESS.**

- 1) Turn ignition switch to OFF.
- 2) Disconnect connector from ABSCM&H/U.
- 3) Depress brake pedal.
- 4) Measure voltage between ABSCM&H/U connector and chassis ground.

**Connector & terminal (F49) No. 2 — Chassis ground:**

- CHECK** : Is the voltage between 10 V and 15 V?
- YES** : Go to step 10AF5.
- NO** : Repair harness between stop light switch and ABSCM&H/U connector.

**10AF5 CHECK POOR CONTACT IN CONNECTORS.**

- CHECK** : Is there poor contact in connector between stop light switch and ABSCM&H/U? <Ref. to FOREWORD [T3C1].☆10>
- YES** : Repair connector.
- NO** : Go to step 10AF6.

**10AF6 CHECK ABSCM&H/U.**

- 1) Connect all connectors.
  - 2) Erase the memory.
  - 3) Perform inspection mode.
  - 4) Read out the trouble code.
- CHECK** : Is the same trouble code as in the current diagnosis still being output?
  - YES** : Replace ABSCM&H/U.
  - NO** : Go to step 10AF7.

**10AF7 CHECK ANY OTHER TROUBLE CODES APPEARANCE.**

- CHECK** : Are other trouble codes being output?
- YES** : Proceed with the diagnosis corresponding to the trouble code.
- NO** : A temporary poor contact.

D•NEW 56 (FB1)  
G SENSOR LINE

B4M0974

**AG: TROUBLE CODE 56 G SENSOR LINE**  
**— OPEN OR SHORT CIRCUIT OF G SENSOR —**

**DIAGNOSIS:**

- Faulty G sensor output voltage

**TROUBLE SYMPTOM:**

- ABS does not operate.

**WIRING DIAGRAM:**

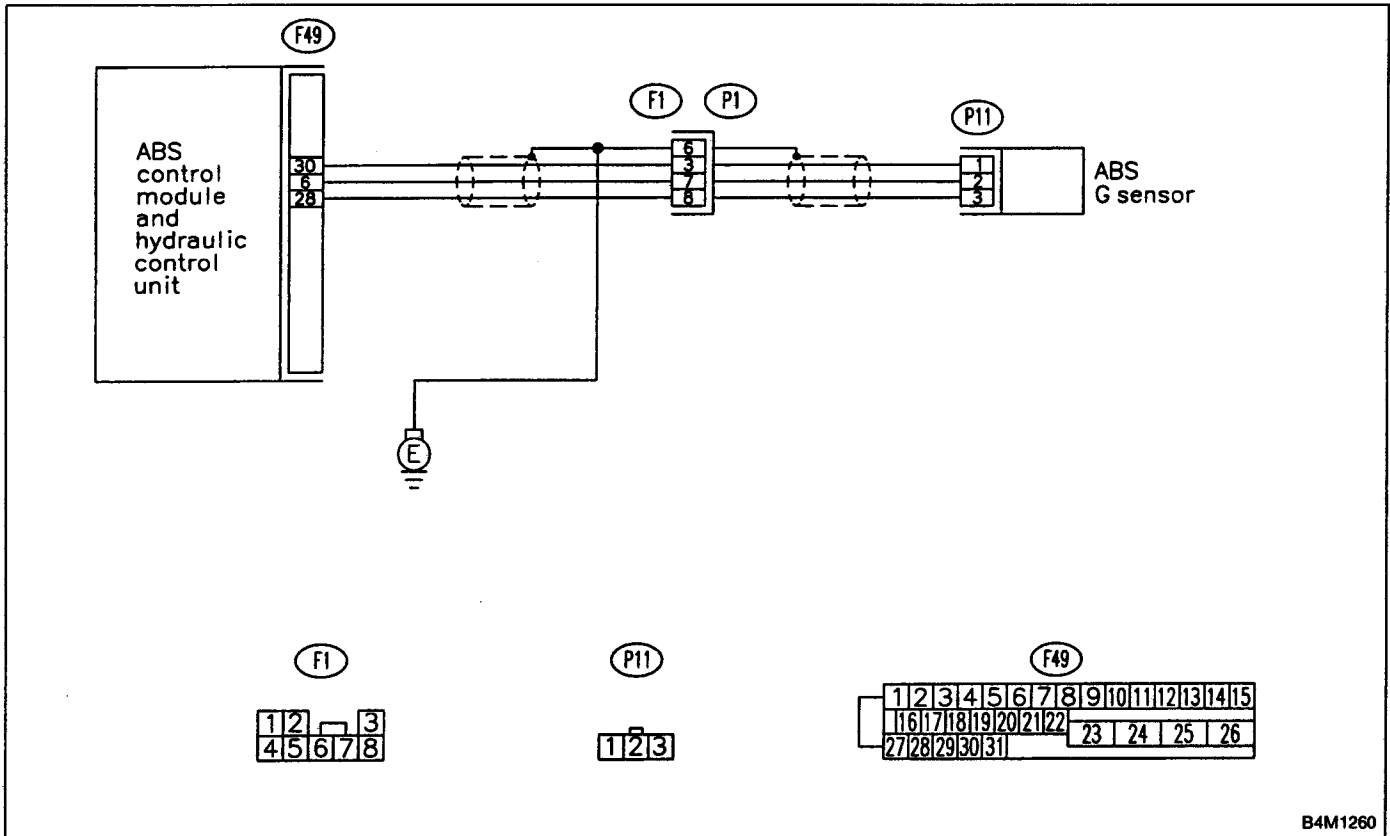

1997 (F00)  
ABS 4WD•AT

H4M1117

G-SENS (F10)  
2.30 V

B4M0927

**10AG1****CHECK SPECIFICATIONS OF ABSCM&H/U USING SELECT MONITOR.**

- 1) Press [F], [0] and [0] on the select monitor.
- 2) Read the select monitor display.

**CHECK** : *Is an ABSCM&H/U for 4WD model installed on a FWD model?*

**YES** : Replace ABSCM&H/U.

**NO** : Go to step **10AG2**.

**10AG2****CHECK OUTPUT OF G SENSOR USING SELECT MONITOR.**

- 1) Press [F], [1] and [0] on the select monitor.
- 2) Read the select monitor display.

**CHECK** : *Is the indicated reading between 2.1 and 2.5 V when the G sensor is in horizontal position?*

**YES** : Go to step **10AG3**.

**NO** : Go to step **10AG6**.

**10AG3****CHECK POOR CONTACT IN CONNECTORS.**

**CHECK** : *Is there poor contact in connector between ABSCM&H/U and G sensor? <Ref. to FOREWORD [T3C1].☆10>*

**YES** : Repair connector.

**NO** : Go to step **10AG4**.

**10AG4****CHECK ABSCM&H/U.**

- 1) Connect all connectors.
- 2) Erase the memory.
- 3) Perform inspection mode.
- 4) Read out the trouble code.

**CHECK** : *Is the same trouble code as in the current diagnosis still being output?*

**YES** : Replace ABSCM&H/U.

**NO** : Go to step **10AG5**.

**10AG5****CHECK ANY OTHER TROUBLE CODES APPEARANCE.**

**CHECK** : *Are other trouble codes being output?*

**YES** : Proceed with the diagnosis corresponding to the trouble code.

**NO** : A temporary poor contact.

FR	(FE5)
0	km/h
B4M0977	

**10AG6 CHECK FREEZE FRAME DATA.**

- 1) Press [F], [E] and [5] on the select monitor.
- 2) Read the select monitor display.

**CHECK** : *Is the reading indicated on monitor display 0 km?*

**YES** : Go to step **10AG7**.

**NO** : Go to step **10AG15**.

FL	(FE6)
0	km/h
B4M0978	

**10AG7 CHECK FREEZE FRAME DATA.**

- 1) Press the scroll key so that FE6 appears on the monitor display.
- 2) Read the select monitor display.

**CHECK** : *Is the reading indicated on monitor display 0 km?*

**YES** : Go to step **10AG8**.

**NO** : Go to step **10AG15**.

RR	(FE7)
0	km/h
B4M0979	

**10AG8 CHECK FREEZE FRAME DATA.**

- 1) Press the scroll key so that FE7 appears on the monitor display.
- 2) Read the select monitor display.

**CHECK** : *Is the reading indicated on monitor display 0 km?*

**YES** : Go to step **10AG9**.

**NO** : Go to step **10AG15**.

RL	(FE8)
0	km/h
B4M0980	

**10AG9 CHECK FREEZE FRAME DATA.**

- 1) Press the scroll key so that FE8 appears on the monitor display.
- 2) Read the select monitor display.

**CHECK** : *Is the reading indicated on monitor display 0 km?*

**YES** : Go to step **10AG10**.

**NO** : Go to step **10AG15**.

G-SENS	(FE14)
3.70	V
B4M0981	

**10AG10 CHECK FREEZE FRAME DATA.**

- 1) Press the scroll key so that FE14 appears on the monitor display.
- 2) Read the select monitor display.

**CHECK** : *Is the reading indicated on monitor display more than 3.65 V?*

**YES** : Go to step **10AG11**.

**NO** : Go to step **10AG15**.

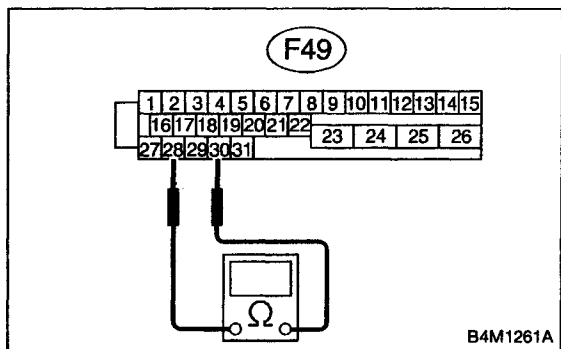

**10AG11 CHECK OPEN CIRCUIT IN G SENSOR OUTPUT HARNESS AND GROUND HARNESS.**

- 1) Turn ignition switch to OFF.
- 2) Disconnect connector from ABSCM&H/U.
- 3) Measure resistance between ABSCM&H/U connector terminals.

**Connector & terminal (F49) No. 30 — No. 28:**

- CHECK** : Is the resistance between 4.3 and 4.9 kΩ?
- YES** : Go to step **10AG12**.
- NO** : Repair harness/connector between G sensor and ABSCM&H/U.

**10AG12 CHECK POOR CONTACT IN CONNECTORS.**

- CHECK** : Is there poor contact in connector between ABSCM&H/U and G sensor? < Ref. to **FOREWORD [T3C1].☆10** >
- YES** : Repair connector.
- NO** : Go to step **10AG13**.

**10AG13 CHECK ABSCM&H/U.**

- 1) Connect all connectors.
  - 2) Erase the memory.
  - 3) Perform inspection mode.
  - 4) Read out the trouble code.
- CHECK** : Is the same trouble code as in the current diagnosis still being output?
- YES** : Replace ABSCM&H/U.
- NO** : Go to step **10AG14**.

**10AG14 CHECK ANY OTHER TROUBLE CODES APPEARANCE.**

- CHECK** : Are other trouble codes being output?
- YES** : Proceed with the diagnosis corresponding to the trouble code.
- NO** : A temporary poor contact.

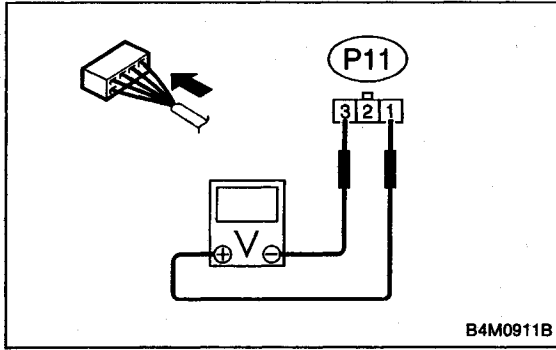

**10AG15 CHECK INPUT VOLTAGE OF G SENSOR.**

- 1) Turn ignition switch to OFF.
- 2) Remove console box.
- 3) Disconnect G sensor from body. (Do not disconnect connector.)
- 4) Turn ignition switch to ON.
- 5) Measure voltage between G sensor connector terminals.

**Connector & terminal**

**(P11) No. 1 (+) — No. 3 (-):**

**CHECK** : Is the voltage between 4.75 and 5.25 V?

**YES** : Go to step **10AG16**.

**NO** : Repair harness/connector between G sensor and ABSCM&H/U.

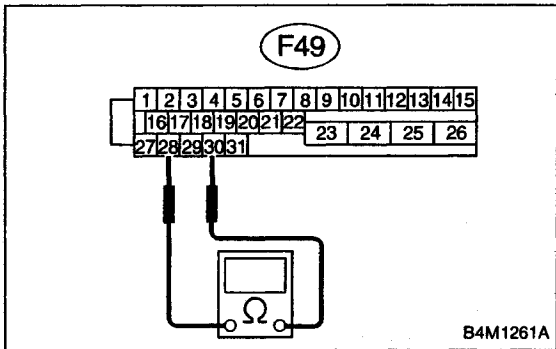

**10AG16 CHECK OPEN CIRCUIT IN G SENSOR OUTPUT HARNESS AND GROUND HARNESS.**

- 1) Turn ignition switch to OFF.
- 2) Disconnect connector from ABSCM&H/U.
- 3) Measure resistance between ABSCM&H/U connector terminals.

**Connector & terminal**

**(F49) No. 30 — No. 28:**

**CHECK** : Is the resistance between 4.3 and 4.9 kΩ?

**YES** : Go to step **10AG17**.

**NO** : Repair harness/connector between G sensor and ABSCM&H/U.

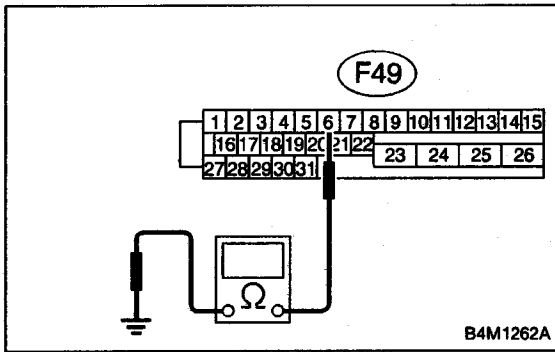

**10AG17 CHECK GROUND SHORT IN G SENSOR OUTPUT HARNESS.**

- 1) Disconnect connector from G sensor.
- 2) Measure resistance between ABSCM&H/U connector and chassis ground.

**Connector & terminal (F49) No. 6 — Chassis ground:**

- CHECK** : Is the resistance more than 1 MΩ?
- YES** : Go to step **10AG18**.
- NO** : Repair harness between G sensor and ABSCM&H/U.

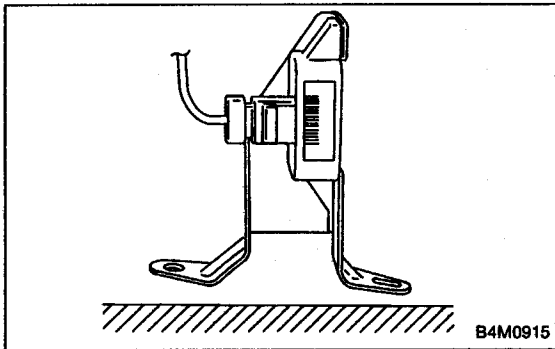

**10AG18 CHECK G SENSOR.**

- 1) Connect connector to G sensor.
- 2) Connect connector to ABSCM&H/U.
- 3) Turn ignition switch to ON.
- 4) Measure voltage between G sensor connector terminals.

**Connector & terminal (P11) No. 2 (+) — No. 1 (-):**

- CHECK** : Is the voltage between 2.1 and 2.5 V when G sensor is horizontal?
- YES** : Go to step **10AG19**.
- NO** : Replace G sensor.

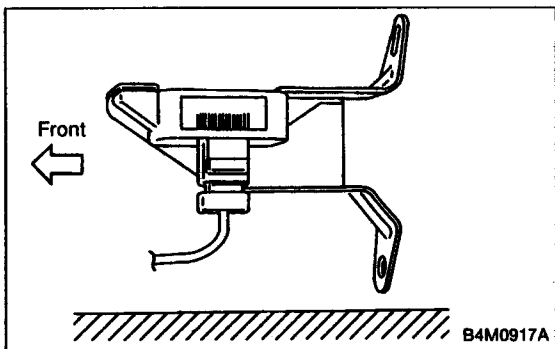

**10AG19 CHECK G SENSOR.**

Measure voltage between G sensor connector terminals.

**Connector & terminal (P11) No. 2 (+) — No. 1 (-):**

- CHECK** : Is the voltage between 3.7 and 4.1 V when G sensor is inclined forwards to 90°?
- YES** : Go to step **10AG20**.
- NO** : Replace G sensor.

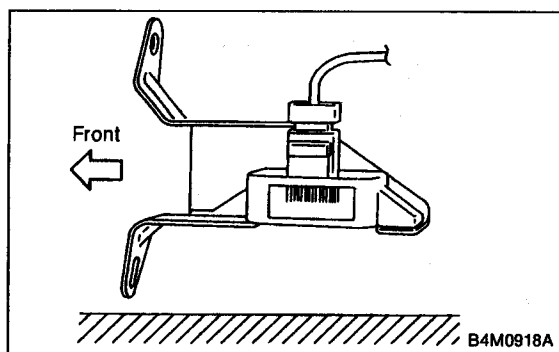

**10AG20 CHECK G SENSOR.**

Measure voltage between G sensor connector terminals.

**Connector & terminal**

**(P11) No. 2 (+) — No. 1 (-):**

**CHECK** : **Is the voltage between 0.5 and 0.9 V when G sensor is inclined backwards to 90°?**

**YES** : Go to step **10AG21**.

**NO** : Replace G sensor.

**10AG21 CHECK POOR CONTACT IN CONNECTORS.**

Turn ignition switch to OFF.

**CHECK** : **Is there poor contact in connector between ABSCM&HIU and G sensor? <Ref. to FOREWORD [T3C1].☆10>**

**YES** : Repair connector.

**NO** : Go to step **10AG22**.

**10AG22 CHECK ABSCM&H/U.**

- 1) Connect all connectors.
- 2) Erase the memory.
- 3) Perform inspection mode.
- 4) Read out the trouble code.

**CHECK** : **Is the same trouble code as in the current diagnosis still being output?**

**YES** : Replace ABSCM&H/U.

**NO** : Go to step **10AG23**.

**10AG23 CHECK ANY OTHER TROUBLE CODES APPEARANCE.**

**CHECK** : **Are other trouble codes being output?**

**YES** : Proceed with the diagnosis corresponding to the trouble code.

**NO** : A temporary poor contact.

**D•NEW 56 (FB1)  
G SENSOR +B**

B4M0982

**AH: TROUBLE CODE 56 G SENSOR + B  
— BATTERY SHORT OF G SENSOR —**

**DIAGNOSIS:**

- Faulty G sensor output voltage

**TROUBLE SYMPTOM:**

- ABS does not operate.

**WIRING DIAGRAM:**

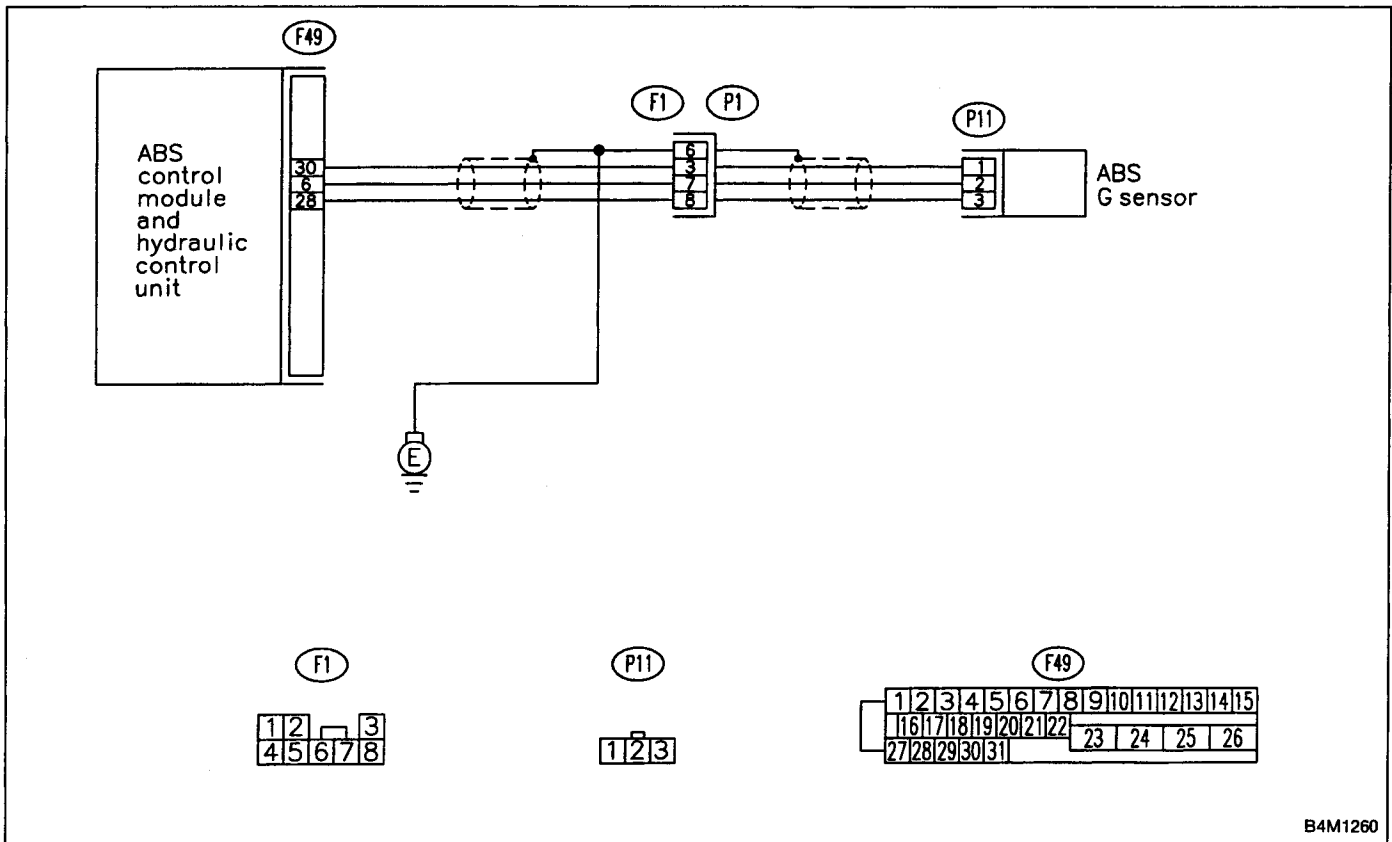

B4M1260

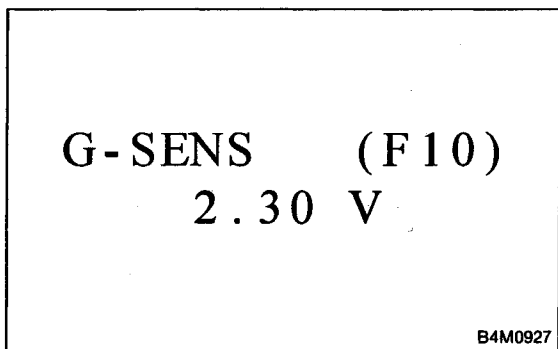

**10AH1 CHECK OUTPUT OF G SENSOR USING SELECT MONITOR.**

- 1) Press [F], [1] and [0] on the select monitor.
- 2) Read the select monitor display.

**CHECK** : Is the indicated reading between 2.1 and 2.5 V when the G sensor is in horizontal position?

**YES** : Replace ABSCM&H/U.

**NO** : Go to step **10AH2**.

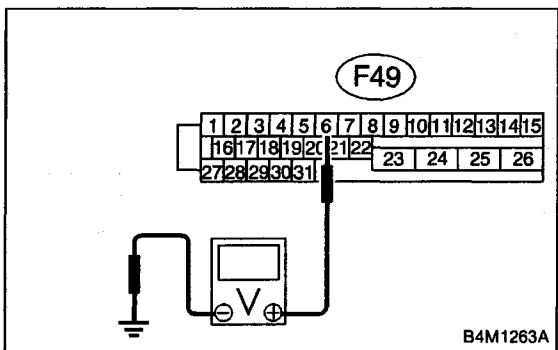

**10AH2 CHECK BATTERY SHORT OF HARNESS.**

- 1) Turn ignition switch to OFF.
- 2) Remove console box.
- 3) Disconnect connector from G sensor.
- 4) Disconnect connector from ABSCM&H/U.
- 5) Measure voltage between ABSCM&H/U connector and chassis ground.

**Connector & terminal**

**(F49) No. 6 (+) — Chassis ground (-):**

**CHECK** : Is the voltage less than 1 V?

**YES** : Go to step **10AH3**.

**NO** : Repair harness between G sensor and ABSCM&H/U.

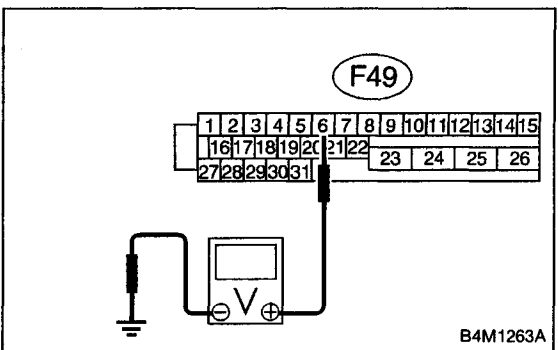

**10AH3 CHECK BATTERY SHORT OF HARNESS.**

- 1) Turn ignition switch to ON.
- 2) Measure voltage between ABSCM&H/U connector and chassis ground.

**Connector & terminal**

**(F49) No. 6 (+) — Chassis ground (-):**

**CHECK** : Is the voltage less than 1 V?

**YES** : Go to step **10AH4**.

**NO** : Repair harness between G sensor and ABSCM&H/U.

<b>10AH4</b>	<b>CHECK ABSCM&amp;H/U.</b>
--------------	-----------------------------

- 1) Turn ignition switch to OFF.
- 2) Connect all connectors.
- 3) Erase the memory.
- 4) Perform inspection mode.
- 5) Read out the trouble code.

**CHECK** : *Is the same trouble code as in the current diagnosis still being output?*

**YES** : Replace ABSCM&H/U.

**NO** : Go to step **10AH5**.

<b>10AH5</b>	<b>CHECK ANY OTHER TROUBLE CODES APPEARANCE.</b>
--------------	--

**CHECK** : *Are other trouble codes being output?*

**YES** : Proceed with the diagnosis corresponding to the trouble code.

**NO** : A temporary poor contact.

D•NEW 56 (FB1)  
G SENSOR H $\mu$

B4M0984

**AI: TROUBLE CODE 56 G SENSOR H $\mu$**   
**— ABNORMAL G SENSOR HIGH  $\mu$  OUTPUT —**

**DIAGNOSIS:**

- Faulty G sensor output voltage

**TROUBLE SYMPTOM:**

- ABS does not operate.

**WIRING DIAGRAM:**

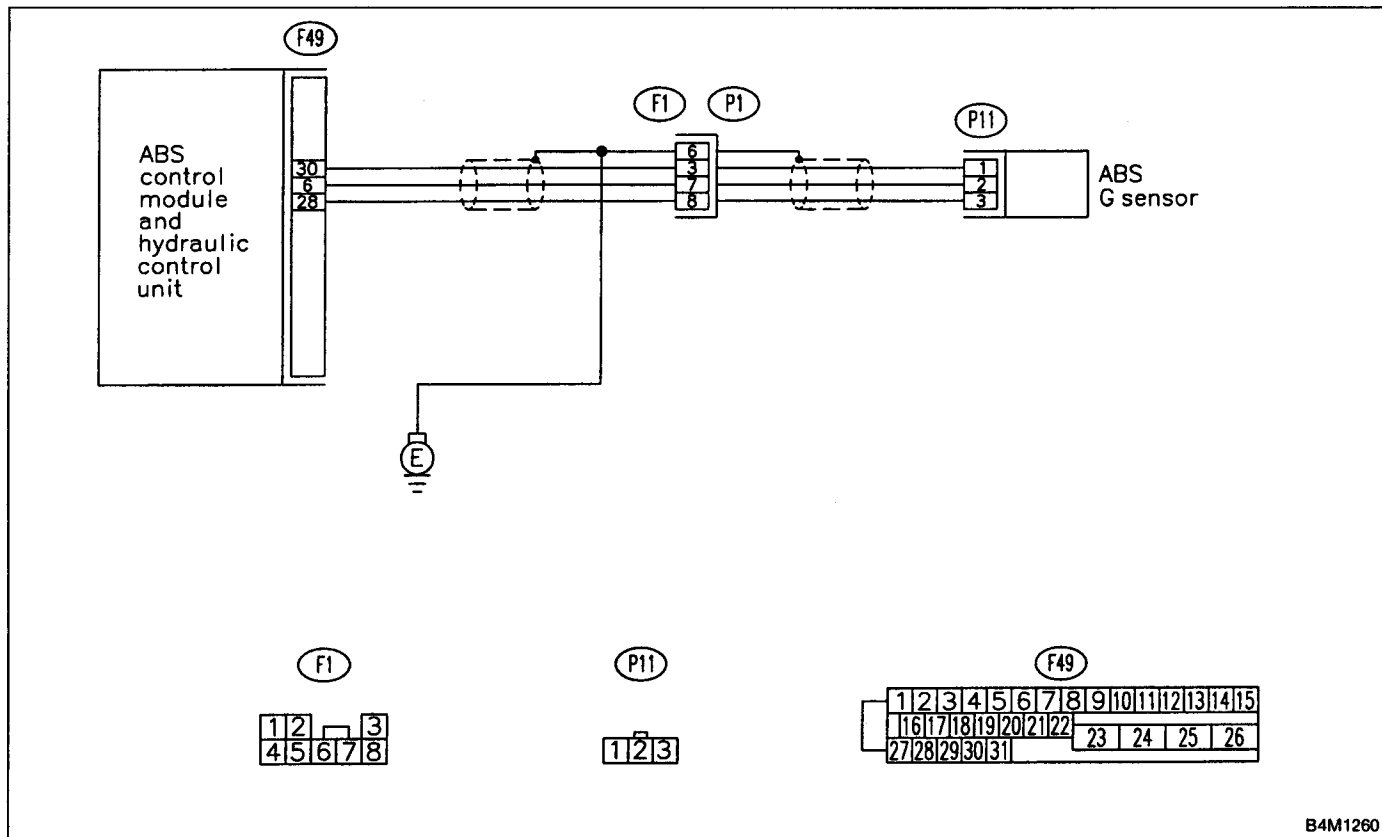

B4M1260

G-SENS (F10)  
2.30 V

B4M0927

<b>10AI1</b>	<b>CHECK OUTPUT OF G SENSOR USING SELECT MONITOR.</b>
--------------	---

- 1) Press [F], [1] and [0] on the select monitor.
- 2) Read the select monitor display.

**CHECK** : *Is the indicated reading  $2.3 \pm 0.2$  V when the G sensor is in horizontal position?*

**YES** : Go to step **10AI2**.

**NO** : Go to step **10AI6**.

<b>10AI2</b>	<b>CHECK POOR CONTACT IN CONNECTORS.</b>
--------------	--

Turn ignition switch to OFF.

**CHECK** : *Is there poor contact in connector between ABSCM&H/U and G sensor? < Ref. to FOREWORD [T3C1].☆10 >*

**YES** : Repair connector.

**NO** : Go to step **10AI3**.

<b>10AI3</b>	<b>CHECK ABSCM&amp;H/U.</b>
--------------	-----------------------------

- 1) Connect all connectors.
- 2) Erase the memory.
- 3) Perform inspection mode.
- 4) Read out the trouble code.

**CHECK** : *Is the same trouble code as in the current diagnosis still being output?*

**YES** : Replace ABSCM&H/U.

**NO** : Go to step **10AI4**.

<b>10AI4</b>	<b>CHECK ANY OTHER TROUBLE CODES APPEARANCE.</b>
--------------	--

**CHECK** : *Are other trouble codes being output?*

**YES** : Proceed with the diagnosis corresponding to the trouble code.

**NO** : A temporary poor contact.

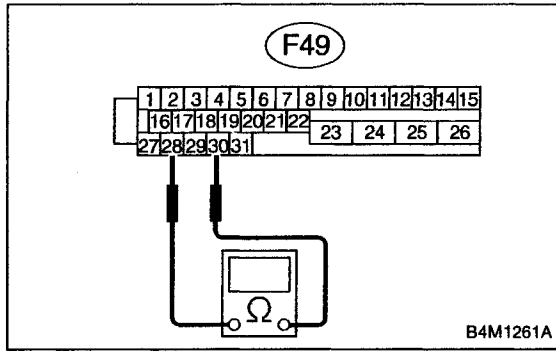

**10A15 CHECK OPEN CIRCUIT IN G SENSOR OUTPUT HARNESS AND GROUND HARNESS.**

- 1) Turn ignition switch to OFF.
- 2) Disconnect connector from ABSCM&H/U.
- 3) Measure resistance between ABSCM&H/U connector terminals.

**Connector & terminal**  
**(F49) No. 30 — No. 28:**

- CHECK** : Is the resistance between 4.3 and 4.9 kΩ?
- YES** : Go to step **10A16**.
- NO** : Repair harness/connector between G sensor and ABSCM&H/U.

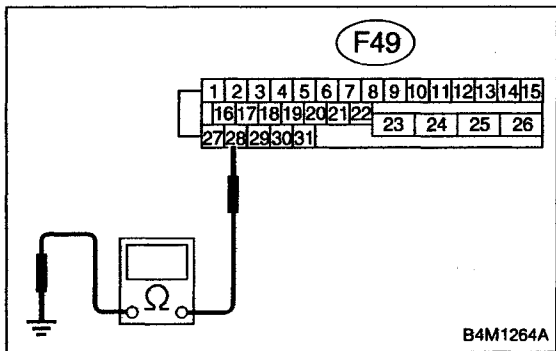

**10A16 CHECK GROUND SHORT OF HARNESS.**

Measure resistance between ABSCM&H/U connector and chassis ground.

**Connector & terminal**  
**(F49) No. 28 — Chassis ground:**

- CHECK** : Is the resistance more than 1 MΩ?
- YES** : Go to step **10A17**.
- NO** : Repair harness between G sensor and ABSCM&H/U.  
 Replace ABSCM&H/U.

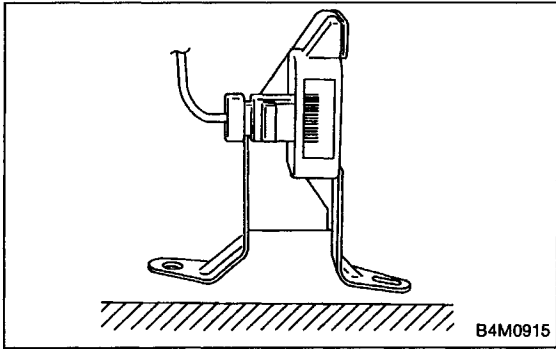

**10A17 CHECK G SENSOR.**

- 1) Remove console box.
- 2) Remove G sensor from vehicle.
- 3) Connect connector to G sensor.
- 4) Connect connector to ABSCM&H/U.
- 5) Turn ignition switch to ON.
- 6) Measure voltage between G sensor connector terminals.

**Connector & terminal**

**(P11) No. 2 (+) — No. 1 (-):**

**CHECK** : Is the voltage between 2.1 and 2.5 V when G sensor is horizontal?

**YES** : Go to step **10A18**.

**NO** : Replace G sensor.

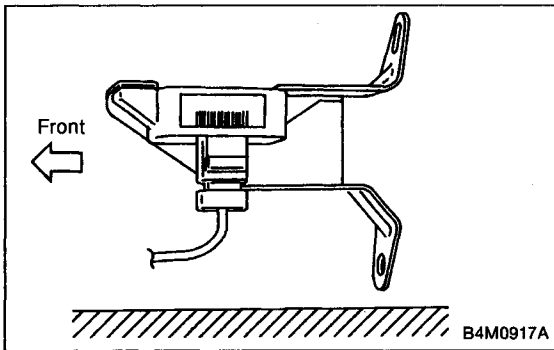

**10A18 CHECK G SENSOR.**

Measure voltage between G sensor connector terminals.

**Connector & terminal**

**(R70) No. 2 (+) — No. 1 (-):**

**CHECK** : Is the voltage between 3.7 and 4.1 V when G sensor is inclined forwards to 90°?

**YES** : Go to step **10A19**.

**NO** : Replace G sensor.

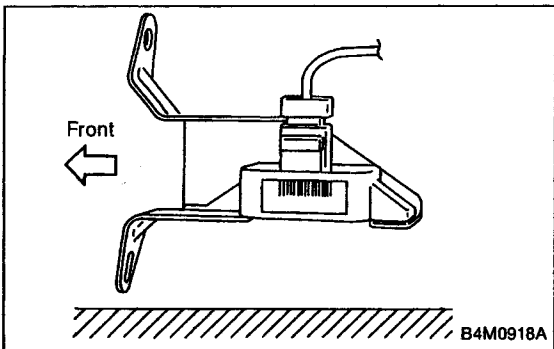

**10A19 CHECK G SENSOR.**

Measure voltage between G sensor connector terminals.

**Connector & terminal**

**(R70) No. 2 (+) — No. 1 (-):**

**CHECK** : Is the voltage between 0.5 and 0.9 V when G sensor is inclined backwards to 90°?

**YES** : Go to step **10A110**.

**NO** : Replace G sensor.



<b>10AI10</b>	<b>CHECK ABSCM&amp;H/U.</b>
---------------	-----------------------------

- 1) Turn ignition switch to OFF.
- 2) Connect all connectors.
- 3) Erase the memory.
- 4) Perform inspection mode.
- 5) Read out the trouble code.

**CHECK** : *Is the same trouble code as in the current diagnosis still being output?*

**YES** : Replace ABSCM&H/U.

**NO** : Go to step **10AI11**.

<b>10AI11</b>	<b>CHECK ANY OTHER TROUBLE CODES APPEARANCE.</b>
---------------	--

**CHECK** : *Are other trouble codes being output?*

**YES** : Proceed with the diagnosis corresponding to the trouble code.

**NO** : A temporary poor contact.

D•NEW 56 (FB1)  
G SENSOR STICK

B4M0813

**AJ: TROUBLE CODE 56 G SENSOR STICK**  
**— G SENSOR OUTPUT IS STUCK —**

**DIAGNOSIS:**

- Faulty G sensor output voltage

**TROUBLE SYMPTOM:**

- ABS does not operate.

**WIRING DIAGRAM:**

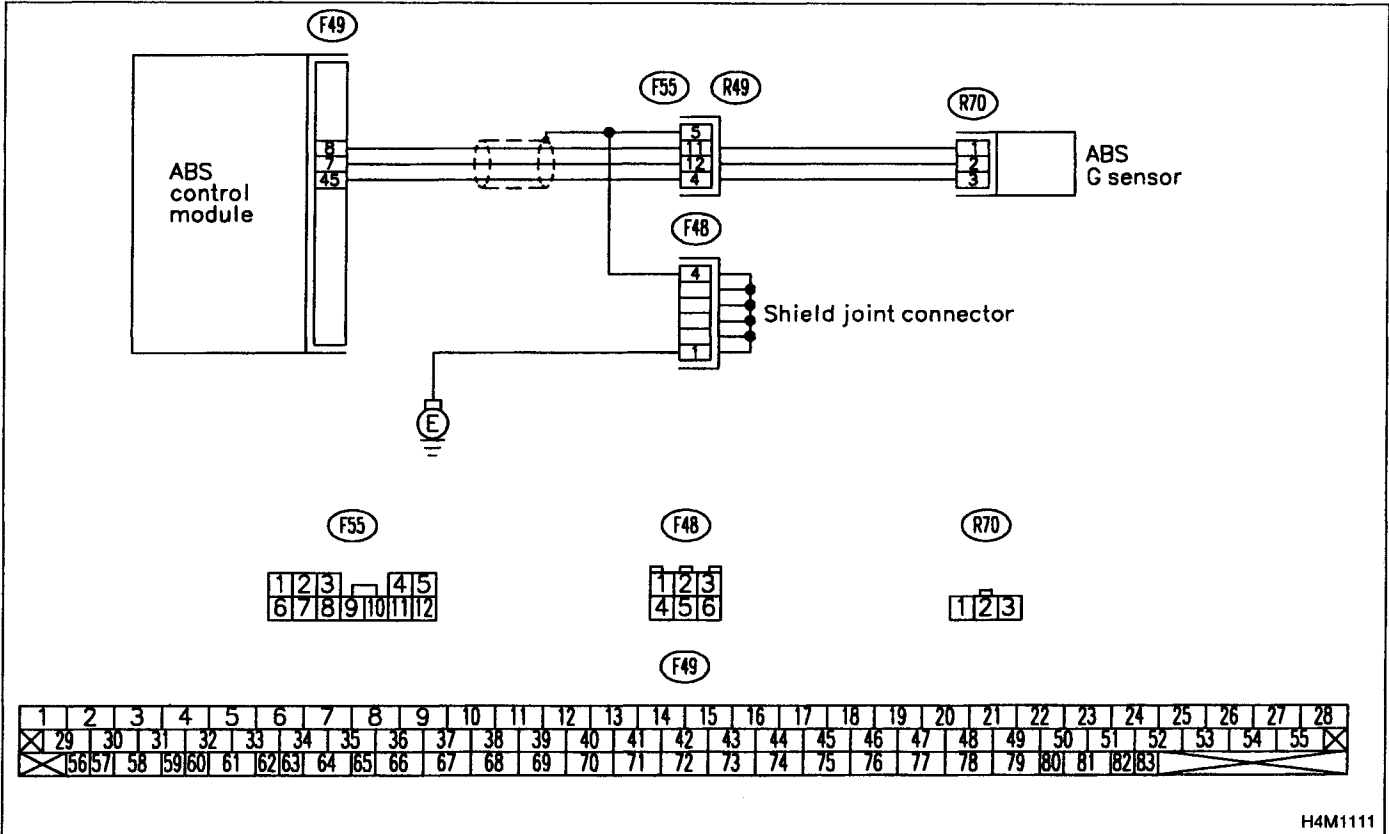

**10AJ1****CHECK ALL FOUR WHEELS FOR FREE TURNING.**

**CHECK** : *Have the wheels been turned freely such as when the vehicle is lifted up, or operated on a rolling road?*

**YES** : The ABS is normal. Erase the trouble code.

**NO** : Go to step **10AJ2**.

G-SENS (F10)  
2.30 V

B4M0927

**10AJ2****CHECK OUTPUT OF G SENSOR USING SELECT MONITOR.**

1) Press [F], [1] and [0] on the select monitor.

2) Read the select monitor display.

**CHECK** : *Is the indicated reading between 2.1 and 2.5 V when the vehicle is in horizontal position?*

**YES** : Go to step **10AJ3**.

**NO** : Go to step **10AJ8**.

Front  
←

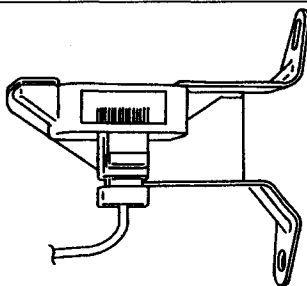

B4M0917A

**10AJ3****CHECK OUTPUT OF G SENSOR USING SELECT MONITOR.**

1) Turn ignition switch to OFF.

2) Remove console box.

3) Remove G sensor from vehicle. (Do not disconnect connector.)

4) Turn ignition switch to ON.

5) Press [F], [1] and [0] on the select monitor.

6) Read the select monitor display.

**CHECK** : *Is the indicated reading between 3.7 and 4.1 V when G sensor is inclined forwards to 90°?*

**YES** : Go to step **10AJ4**.

**NO** : Replace G sensor.

Front  
←

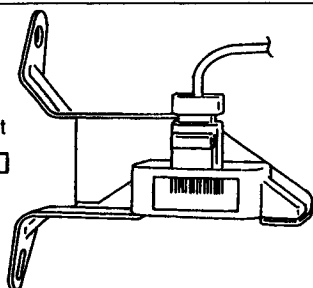

B4M0918A

**10AJ4****CHECK OUTPUT OF G SENSOR USING SELECT MONITOR.**

Read the select monitor display.

**CHECK** : *Is the indicated reading between 0.5 and 0.9 V when G sensor is inclined backwards to 90°?*

**YES** : Go to step **10AJ5**.

**NO** : Replace G sensor.

**10AJ5 CHECK POOR CONTACT IN CONNECTORS.**

Turn ignition switch to OFF.

**CHECK** : *Is there poor contact in connector between ABSCM&H/U and G sensor? <Ref. to FOREWORD [T3C1].☆10>*

**YES** : Repair connector.

**NO** : Go to step **10AJ6**.

**10AJ6 CHECK ABSCM&H/U.**

- 1) Connect all connectors.
- 2) Erase the memory.
- 3) Perform inspection mode.
- 4) Read out the trouble code.

**CHECK** : *Is the same trouble code as in the current diagnosis still being output?*

**YES** : Replace ABSCM&H/U.

**NO** : Go to step **10AJ7**.

**10AJ7 CHECK ANY OTHER TROUBLE CODES APPEARANCE.**

**CHECK** : *Are other trouble codes being output?*

**YES** : Proceed with the diagnosis corresponding to the trouble code.

**NO** : A temporary poor contact.

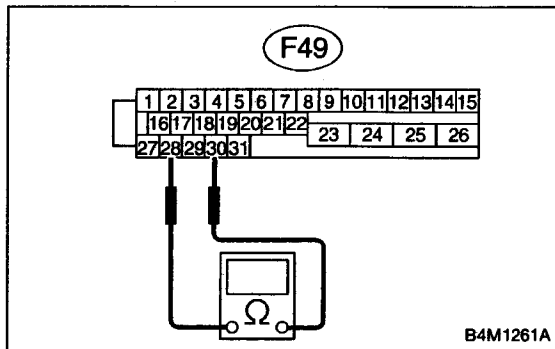
**10AJ8 CHECK OPEN CIRCUIT IN G SENSOR OUTPUT HARNESS AND GROUND HARNESS.**

- 1) Turn ignition switch to OFF.
- 2) Disconnect connector from ABSCM&H/U.
- 3) Measure resistance between ABSCM&H/U connector terminals.

**Connector & terminal**  
(F49) No. 30 — No. 28:

**CHECK** : *Is the resistance between 4.3 and 4.9 kΩ?*

**YES** : Go to step **10AJ9**.

**NO** : Repair harness/connector between G sensor and ABSCM&H/U.

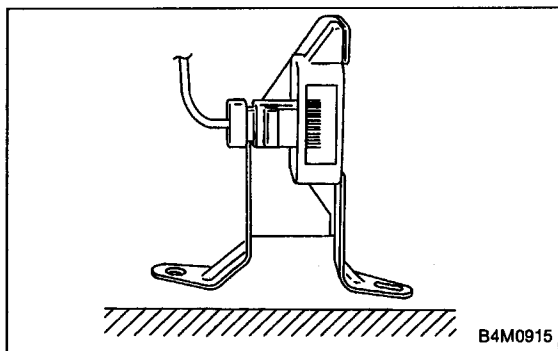

**10AJ9 CHECK G SENSOR.**

- 1) Remove console box.
- 2) Remove G sensor from vehicle.
- 3) Connect connector to G sensor.
- 4) Connect connector to ABSCM&H/U.
- 5) Turn ignition switch to ON.
- 6) Measure voltage between G sensor connector terminals.

**Connector & terminal (P11) No. 2 (+) — No. 1 (-):**

**CHECK** : Is the voltage between 2.1 and 2.5 V when G sensor is horizontal?

**YES** : Go to step 10AJ10.

**NO** : Replace G sensor.

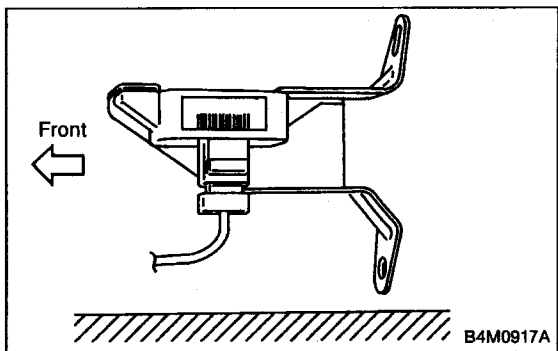

**10AJ10 CHECK G SENSOR.**

Measure voltage between G sensor connector terminals.

**Connector & terminal (P11) No. 2 (+) — No. 1 (-):**

**CHECK** : Is the voltage between 3.7 and 4.1 V when G sensor is inclined forwards to 90°?

**YES** : Go to step 10AJ11.

**NO** : Replace G sensor.

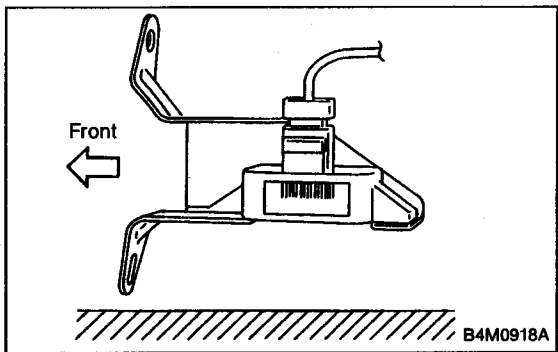

**10AJ11 CHECK G SENSOR.**

Measure voltage between G sensor connector terminals.

**Connector & terminal (P11) No. 2 (+) — No. 1 (-):**

**CHECK** : Is the voltage between 0.5 and 0.9 V when G sensor is inclined backwards to 90°?

**YES** : Go to step 10AJ12.

**NO** : Replace G sensor.

<b>10AJ12</b>	<b>CHECK ABSCM&amp;H/U.</b>
---------------	-----------------------------

- 1) Turn ignition switch to OFF.
- 2) Connect all connectors.
- 3) Erase the memory.
- 4) Perform inspection mode.
- 5) Read out the trouble code.

**CHECK** : *Is the same trouble code as in the current diagnosis still being output?*

**YES** : Replace ABSCM&H/U.

**NO** : Go to step **10AJ13**.

<b>10AJ13</b>	<b>CHECK ANY OTHER TROUBLE CODES APPEARANCE.</b>
---------------	--

**CHECK** : *Are other trouble codes being output?*

**YES** : Proceed with the diagnosis corresponding to the trouble code.

**NO** : A temporary poor contact.