

1. Engine Electrical

A: SPECIFICATIONS

1. EXCEPT 2200 cc MODEL

Item		Designation		
Starter	Type	Reduction type		
	Model	MT TN128000-8311	AT TN128000-8321	
	Manufacturer	NIPPONDENSO TENNESSEE		
	Voltage and output	12 V — 1.0 kW	12 V — 1.4 kW	
	Direction of rotation	Counterclockwise (when observed from pinion)		
	Number of pinion teeth	8	9	
	No-load characteristics	Voltage	11 V	
		Current	90 A or less	
		Rotating speed	3,000 rpm or more	2,900 rpm or more
	Load characteristics	Voltage	8 V	
		Current	280 A or less	370 A or less
		Torque	9.8 N·m (1.0 kg-m, 7.2 ft-lb)	13.7 N·m (1.4 kg-m, 10.1 ft-lb)
		Rotating speed	900 rpm or more	880 rpm or more
	Lock characteristics	Voltage	5 V	
Current		800 A or less	1,050 A or less	
Torque		27.5 N·m (2.8 kg-m, 20.3 ft-lb) or more		
Generator	Type	Rotating-field three-phase type, Voltage regulator built-in type		
	Model	LR185-701H		
	Manufacturer	HITACHI AUTOMOTIVE PRODUCTS		
	Voltage and output	12 V — 85 A		
	Polarity on ground side	Negative		
	Rotating direction	Clockwise (when observed from pulley side)		
	Armature connection	3-phase Y-type		
	Output current	1,500 rpm — 35 A or more 2,500 rpm — 62 A or more 5,000 rpm — 82 A or more		
	Regulated voltage	14.5 ^{+0.3} _{-0.4} V [20°C (68°F)]		
Ignition coil	Model	F-569-01R		
	Manufacturer	Diamond		
	Primary coil resistance	0.69 Ω±10%		
	Secondary coil resistance	21.0 kΩ±15%		
	Insulation resistance between primary terminal and case	More than 10 MΩ		
Spark plug	Type and manufacturer	RC10YC4 CHAMPION Alternate (BKR6E-11 NGK K20PR-U11 NIPPONDENSO)		
	Thread size	mm	14, P = 1.25	
	Spark gap	mm (in)	1.0 — 1.1 (0.039 — 0.043)	

2. 2200 cc MODEL

Item		Designation		
Starter	Type	Reduction type		
	Model	MT TN128000-8311	AT TN128000-8321	
	Manufacturer	NIPPONDENSO TENNESSEE		
	Voltage and output	12 V — 1.0 kW	12 V — 1.4 kW	
	Direction of rotation	Counterclockwise (when observed from pinion)		
	Number of pinion teeth	8	9	
	No-load characteristics	Voltage	11 V	
		Current	90 A or less	
		Rotating speed	3,000 rpm or more	2,900 rpm or more
	Load characteristics	Voltage	8 V	
		Current	280 A or less	370 A or less
		Torque	9.8 N·m (1.0 kg-m, 7.2 ft-lb)	13.7 N·m (1.4 kg-m, 10.1 ft-lb)
		Rotating speed	900 rpm or more	880 rpm or more
	Lock characteristics	Voltage	5 V	
		Current	800 A or less	1,050 A or less
Torque		27.5 N·m (2.8 kg-m, 20.3 ft-lb) or more		
Generator	Type	Rotating-field three-phase type, Voltage regulator built-in type		
	Model	LR185-701H		
	Manufacturer	HITACHI AUTOMOTIVE PRODUCTS		
	Voltage and output	12 V — 85 A		
	Polarity on ground side	Negative		
	Rotating direction	Clockwise (when observed from pulley side)		
	Armature connection	3-phase Y-type		
	Output current	1,500 rpm — 35 A or more 2,500 rpm — 62 A or more 5,000 rpm — 82 A or more		
	Regulated voltage	14.5 ^{+0.3} _{-0.4} V [20°C (68°F)]		
Ignition coil	Model	FH0047-01R		
	Manufacturer	DEMCO		
	Primary coil resistance	0.73 Ω±10%		
	Secondary coil resistance	12.8 kΩ±15%		
	Insulation resistance between primary terminal and case	More than 10 MΩ		
Spark plug	Type and manufacturer	RC10YC4 CHAMPION Alternate (BKR6E-11 NGK K20PR-U11 NIPPONDENSO)		
	Thread size	mm	14, P = 1.25	
	Spark gap	mm (in)	1.0 — 1.1 (0.039 — 0.043)	

1. Starter

1. MT: 128000-8311

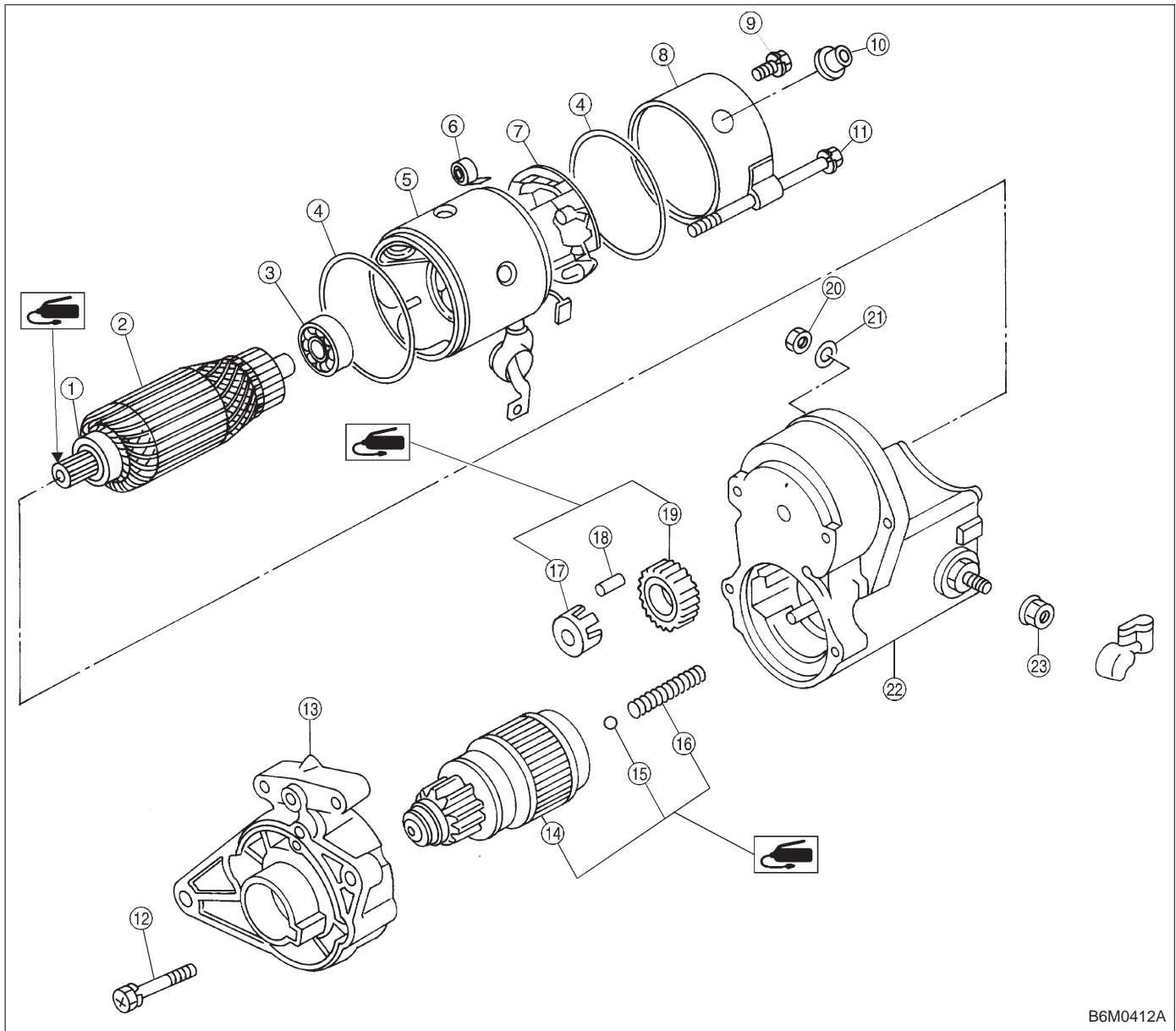

B6M0412A

- ① Front ball bearing
- ② Armature
- ③ Rear ball bearing
- ④ O-ring
- ⑤ Yoke
- ⑥ Brush spring
- ⑦ Brush holder
- ⑧ End frame
- ⑨ Screw & washer
- ⑩ Cover
- ⑪ Through bolt
- ⑫ Screw & washer

- ⑬ Starter housing
- ⑭ Overrunning clutch
- ⑮ Steel ball
- ⑯ Spring
- ⑰ Retainer
- ⑱ Roller
- ⑲ Idle gear
- ⑳ Nut
- ㉑ Spring washer
- ㉒ Magnet switch
- ㉓ Nut

2. AT: 128000-8321

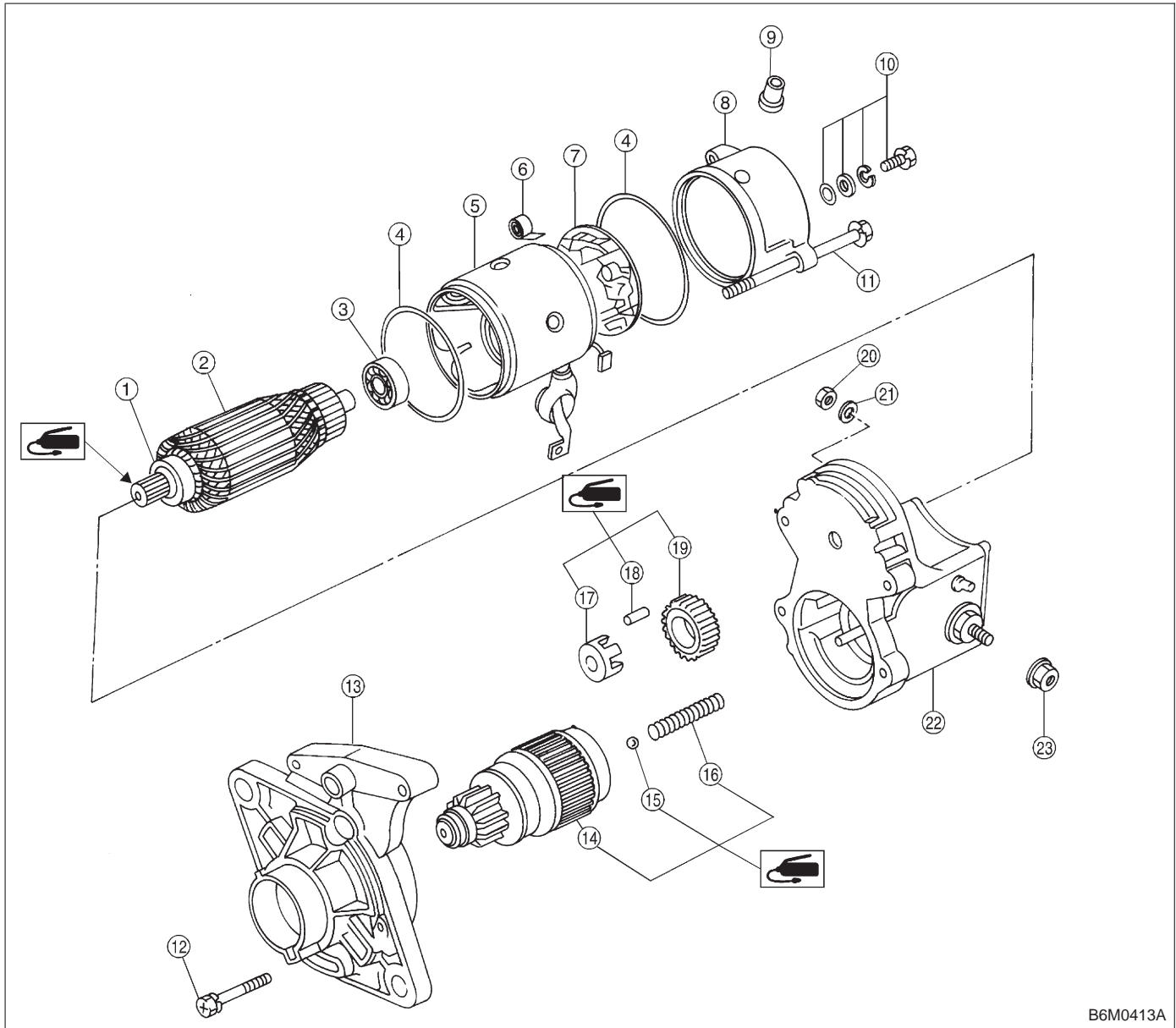

B6M0413A

- | | |
|----------------------|----------------------|
| ① Front ball bearing | ⑬ Starter housing |
| ② Armature | ⑭ Overrunning clutch |
| ③ Rear ball bearing | ⑮ Steel ball |
| ④ O-ring | ⑯ Spring |
| ⑤ Yoke | ⑰ Retainer |
| ⑥ Brush spring | ⑱ Roller |
| ⑦ Brush holder | ⑲ Idle gear |
| ⑧ End frame | ⑳ Nut |
| ⑨ Cover | ㉑ Spring washer |
| ⑩ Screw & washer | ㉒ Magnet switch |
| ⑪ Through bolt | ㉓ Nut |
| ⑫ Screw & washer | |

2. Generator

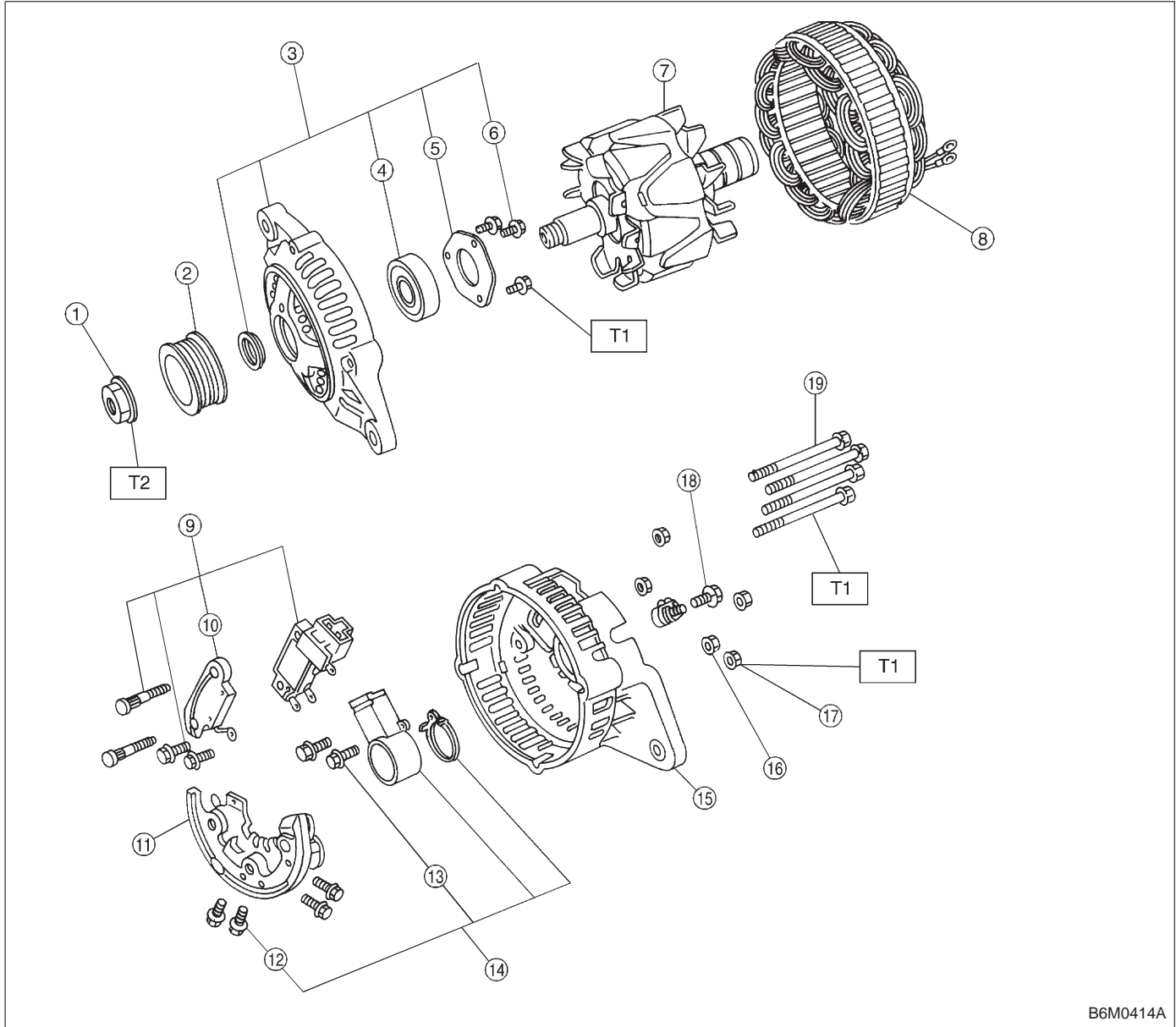

B6M0414A

- ① Pulley nut
- ② Pulley
- ③ Front cover ASSY
- ④ Ball bearing
- ⑤ Bearing retainer
- ⑥ Screw
- ⑦ Rotor
- ⑧ Stator coil
- ⑨ IC regulator ASSY
- ⑩ Condenser
- ⑪ Diode ASSY
- ⑫ Bolt

- ⑬ Bolt
- ⑭ Brush holder ASSY
- ⑮ Rear cover
- ⑯ BAT. terminal
- ⑰ Nut
- ⑱ Bolt
- ⑲ Through bolt

Tightening torque: N·m (kg·m, ft·lb)
T1: 3.1 — 4.4 (0.32 — 0.45, 2.3 — 3.3)
T2: 63.7 — 83.4 (6.5 — 8.5, 47.0 — 61.5)

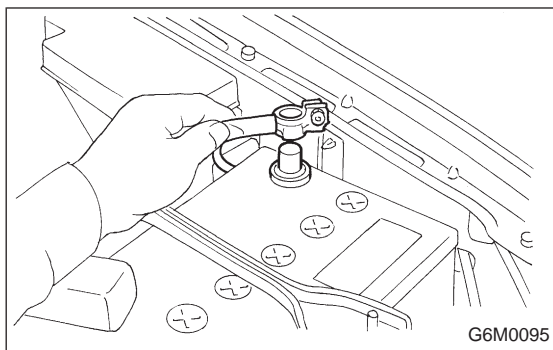

1. Starter

A: REMOVAL AND INSTALLATION

1) Disconnect battery ground cable.

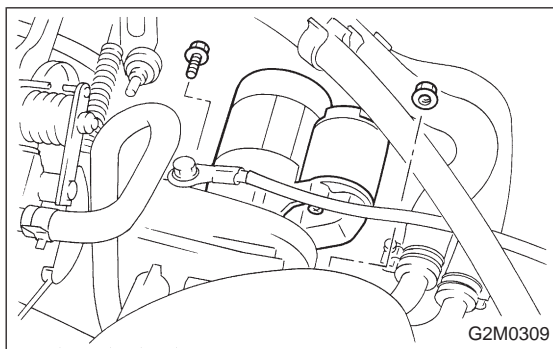

2) Disconnect connector and terminal from starter.

3) Remove starter from transmission.

4) Installation is in the reverse order of removal.

Tightening torque:

$50 \pm 4 \text{ N}\cdot\text{m}$ ($5.1 \pm 0.4 \text{ kg}\cdot\text{m}$, $36.9 \pm 2.9 \text{ ft}\cdot\text{lb}$)

B: TEST

1. MAGNETIC SWITCH

CAUTION:

- The following magnetic switch tests should be performed with specified voltage applied.

- Each test should be conducted within 3 to 5 seconds. Power to be furnished should be one-half the rated voltage.

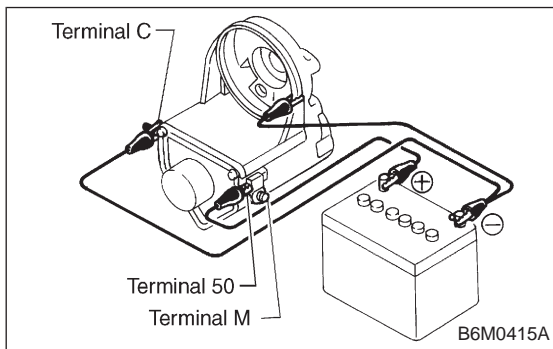

1) Pull-in test

Connect two battery negative leads onto magnetic switch body and terminal C respectively. Then connect battery positive lead onto terminal 50. Pinion should extend when lead connections are made.

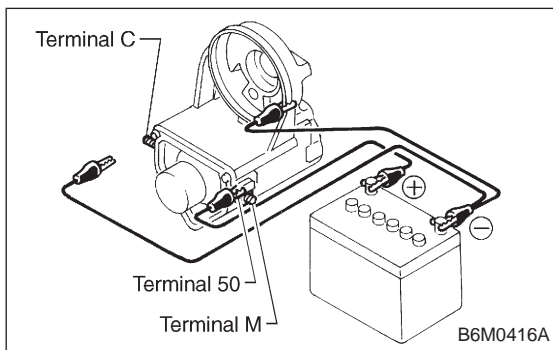

2) Holding-in test

Disconnect lead from terminal C with pinion extended. Pinion should be held in the extended position.

1. Starter

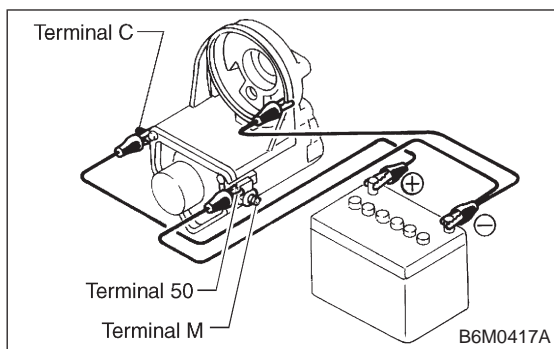

3) Return test

Connect two battery negative leads onto terminal 50 and onto switch body respectively. Then connect battery positive lead onto terminal C. Next, disconnect lead from terminal 50. Pinion should return immediately.

2. PERFORMANCE TEST

The starter is required to produce a large torque and high rotating speed, but these starter characteristics vary with the capacity of the battery. It is therefore important to use a battery with the specified capacity whenever testing the starter.

The starter should be checked for the following three items:

1. No-load test

Measure the maximum rotating speed and current under a no-load state.

2. Load test

Measure the magnitude of current needed to generate the specified torque and rotating speed.

3. Stall test

Measure the torque and current when the armature is locked.

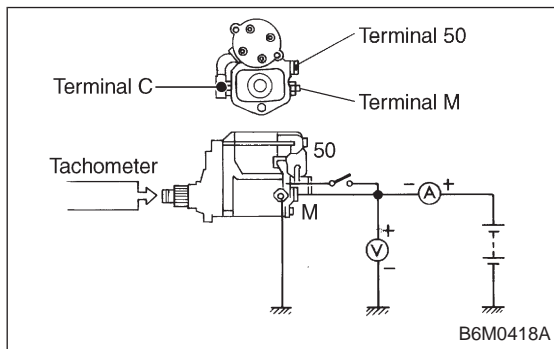

1) No-load test

Run single starter under no-load state, and measure its rotating speed, voltage, and current, using the specified battery. Measured values must meet the following standards:

No-load test (Standard):

Voltage/Current

11 V/90 A, or more

Rotating speed

TN128000-8311: 3,000 rpm, or more

TN128000-8321: 3,350 rpm, or more

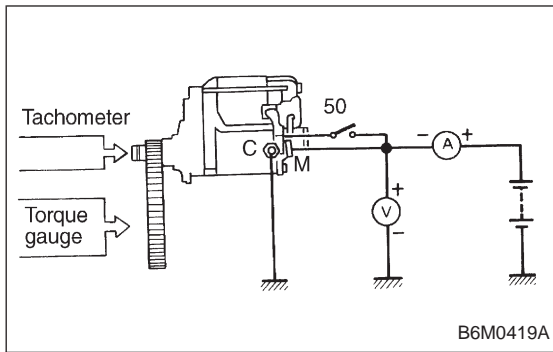

2) Load test (For reference)

Perform this test to check maximum output of starter. Use test bench which is able to apply load (brake) to starter. Measure torque value and rotating speed under the specified voltage and current conditions while controlling braking force applied to starter.

CAUTION:

Change engagement position of overrunning clutch and make sure it is not slipping.

Load test (Standard):

TN128000-8311

Voltage/Load

8 V/9.8 N·m (1.0 kg-m, 7.2 ft-lb)

Current/Speed

280 A max./900 rpm min.

TN128000-8321

Voltage/Load

8 V/13.7 N·m (1.4 kg-m, 10.1 ft-lb)

Current/Speed

370 A, or less/880 rpm, or more

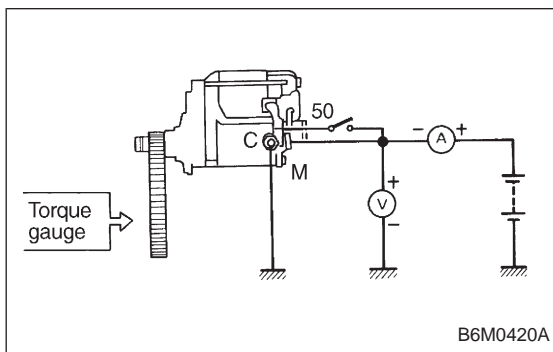

3) Stall test

Using the same test equipment used for load test, apply brake to lock starter armature. Then measure voltage, current, and torque values.

Measured values must meet the following standard.

Stall test (Standard):

TN128000-8311

Voltage/Current

5 V/800 A, or less

Torque

27.5 N·m (2.8 kg-m, 20.3 ft-lb) min.

TN128000-8321

Voltage/Current

5 V/1,050 A, or less

Torque

27.5 N·m (2.8 kg-m, 20.3 ft-lb) min.

NOTE:

Low rotating speed or excessive current during no-load test may be attributable to high rotating resistance of starter due to improper assembling.

Small current and no torque during stall test may be attributable to excessive contact resistance between brush and commutator; whereas, normal current and insufficient torque may be attributable to shorted commutator or poor insulation.

Starter can be considered normal if it passes no-load and stall tests; therefore, load test may be omitted.

C: DISASSEMBLY

1) Disconnect lead wire from magnetic switch.

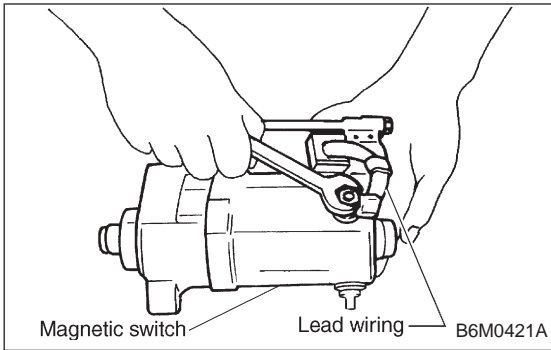

2) Remove through-bolts from end frame.

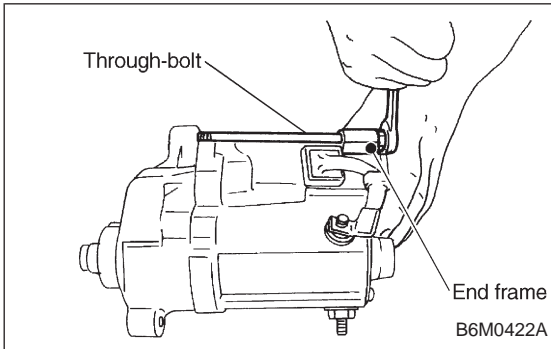

3) Remove yoke from magnetic switch.

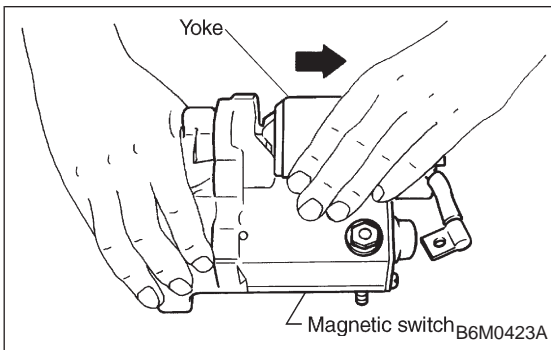

4) Remove screws securing end frame to brush holder.

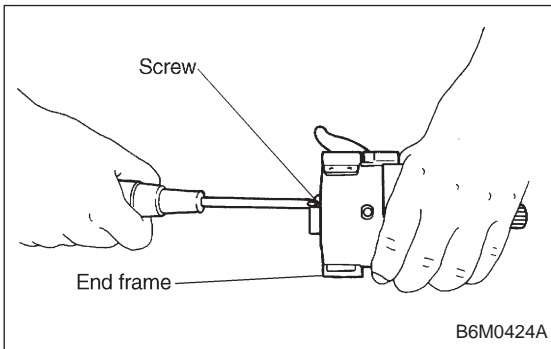

5) Separate yoke from end frame.

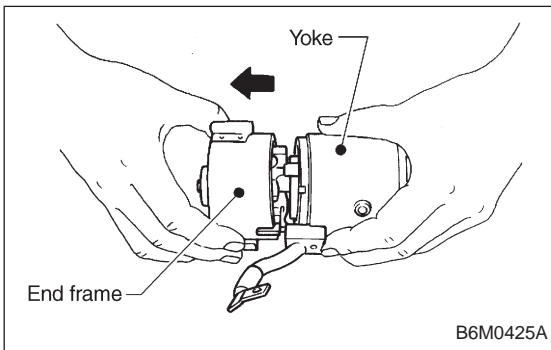

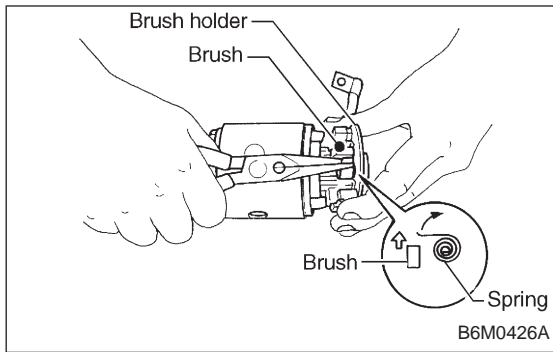

6) Remove brush by lifting up positive (+) side brush spring using long-nose pliers.

CAUTION:
Be careful not to damage brush and commutator.

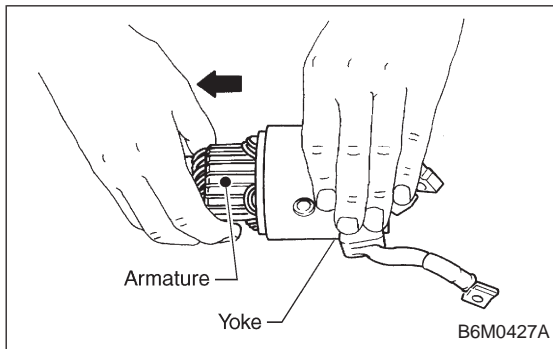

7) Remove armature from yoke.

CAUTION:
Be careful not to drop armature.

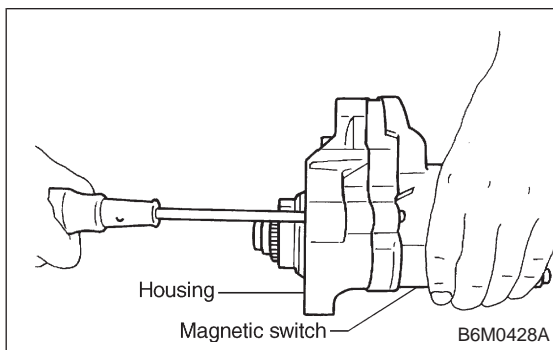

8) Remove screws securing magnetic switch to housing.

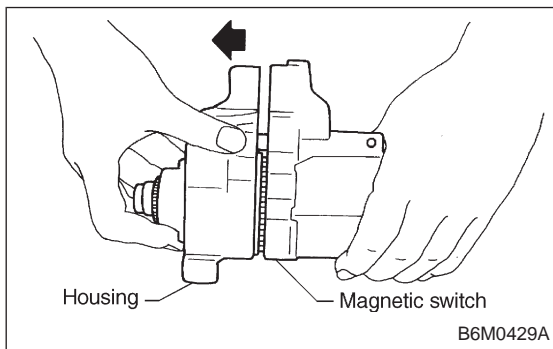

9) Remove housing from magnetic switch.

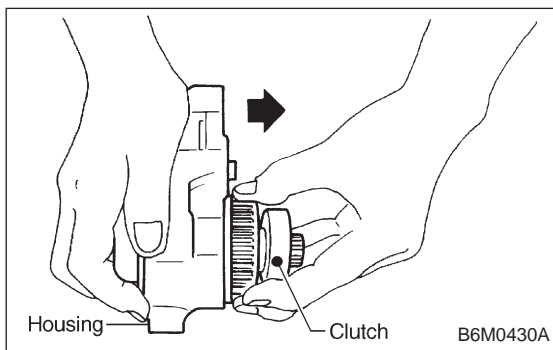

10) Remove clutch from housing.

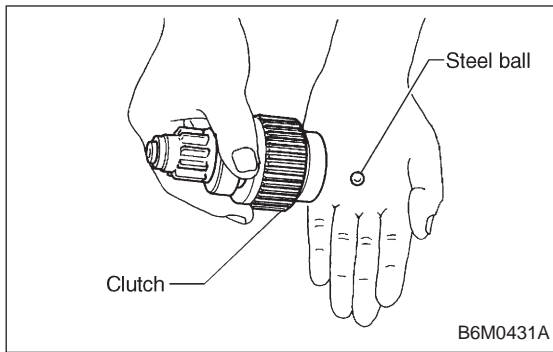

11) Take out steel ball from clutch.

CAUTION:
Be careful not to lose steel ball.

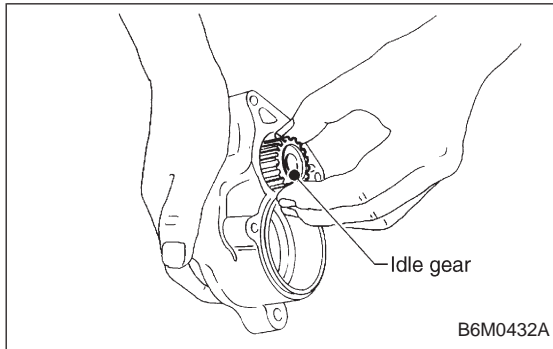

12) Remove idle gear from housing.

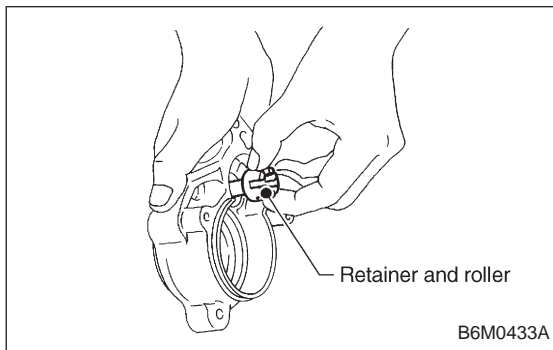

13) Remove retainer and roller from housing.

CAUTION:
Be careful not to drop retainer and roller.

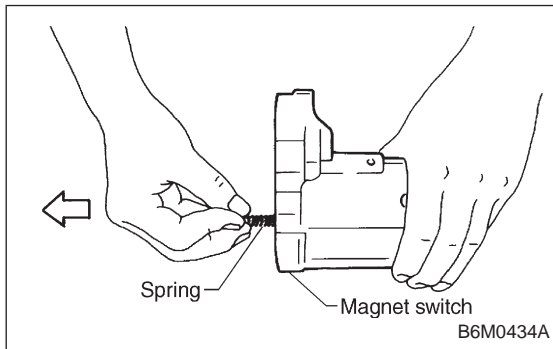

14) Remove coil spring from magnetic switch.

D: INSPECTION

1. ARMATURE

1) Check commutator for any sign of burns or rough surfaces or stepped wear. If wear is of a minor nature, correct it by using sand paper.

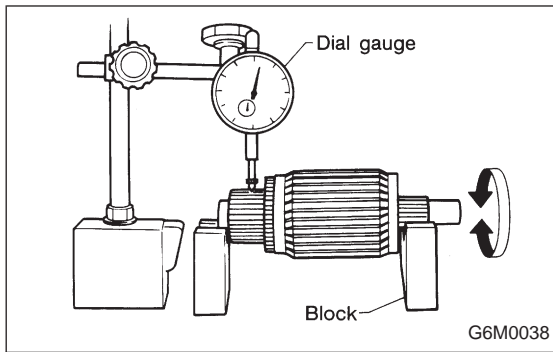

2) Run-out test

Check the commutator run-out and replace if it exceeds the limit.

Commutator run-out:

Standard

0.02 mm (0.0008 in), or less

Service limit

Less than 0.05 mm (0.0020 in)

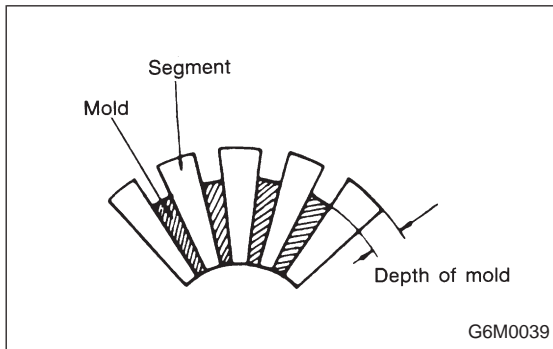

3) Depth of segment mold

Check the depth of segment mold.

Depth of segment mold:

0.6 mm (0.024 in)

Limit

0.2 mm (0.008 in)

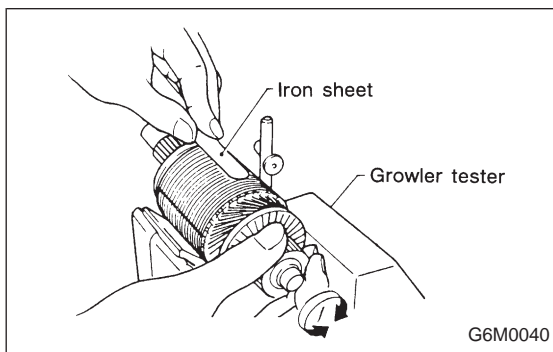

4) Armature short-circuit test

Check armature for short-circuit by placing it on growler tester. Hold a hacksaw blade against armature core while slowly rotating armature. A short-circuited armature will cause the blade to vibrate and to be attracted to core. If the hacksaw blade is attracted or vibrates, the armature, which is short-circuited, must be replaced or repaired.

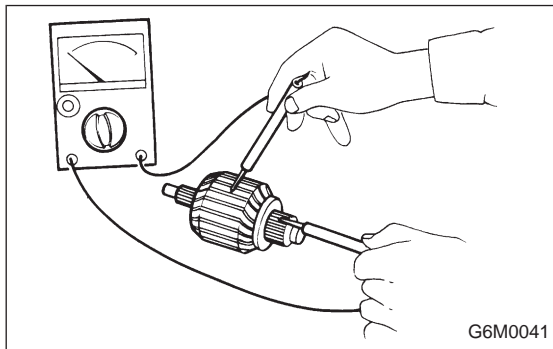

5) Armature ground test

Using circuit tester, touch one probe to the commutator segment and the other to shaft. There should be no continuity. If there is a continuity, armature is grounded. Replace armature if it is grounded.

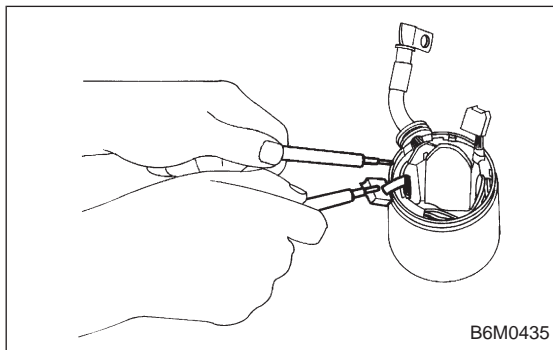

2. YOKE

Make sure pole is set in position.

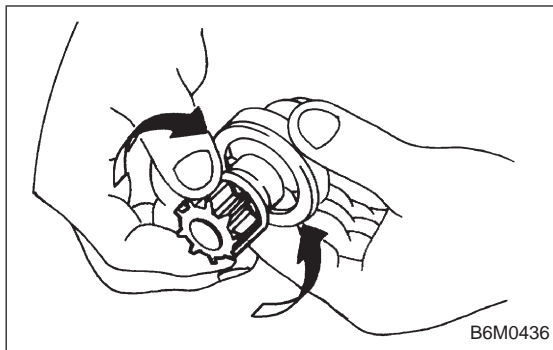

B6M0436

3. OVERRUNNING CLUTCH

Inspect teeth of pinion for wear and damage. Replace if it is damaged. Rotate pinion in direction of rotation (clockwise). It should rotate smoothly. But in opposite direction, it should be locked.

CAUTION:

Do not clean overrunning clutch with oil to prevent grease from flowing out.

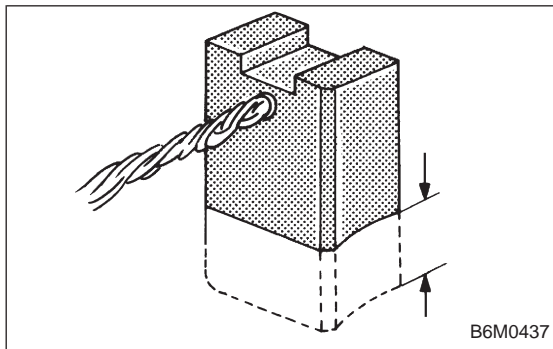

B6M0437

4. BRUSH AND BRUSH HOLDER

1) Brush length

Measure the brush length and replace if it exceeds the service limit.

Replace if abnormal wear or cracks are noticed.

Brush length:

Standard	15 mm (0.59 in)
Service limit	10 mm (0.39 in)

2) Brush movement

Be sure brush moves smoothly inside brush holder.

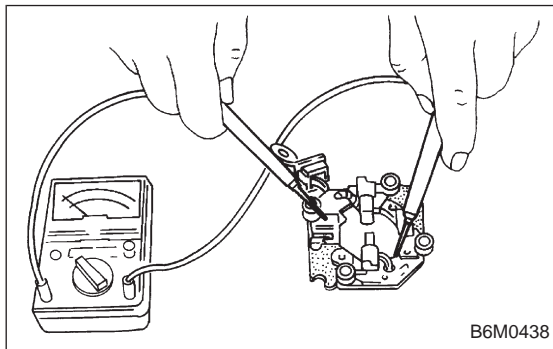

B6M0438

3) Insulation resistance of brush holder

Be sure there is no continuity between brush holder and its plate.

4) Brush spring force

Measure brush spring force with a spring scale. If it is less than the service limit, replace brush spring.

Brush spring force:

Standard	18.6 N (1.9 kg, 4.2 lb) (when new)
Service limit	6.9 N (0.7 kg, 1.5 lb)

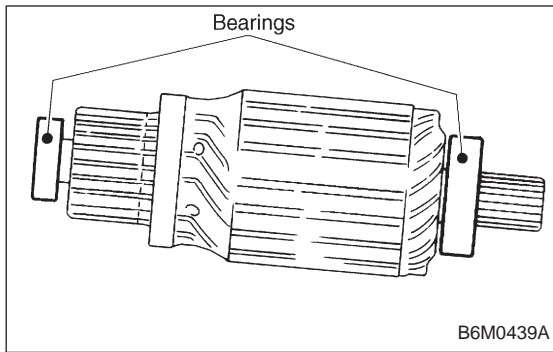

5. BEARING

- 1) Rotate bearing by hand; no binding should exist.
- 2) Rotate bearing rapidly; no abnormal noise should be heard.

E: ASSEMBLY

Assembly is in the reverse order of disassembly procedures. Observe the following:

- 1) Before assembling, lubricate disassembled parts at the points shown in "COMPONENT PARTS 6-1 [C101] and 6-1 [C102]".

Grease:

ESSO BEACON 325

SHELL ALVANIA GREASE RA or equivalent

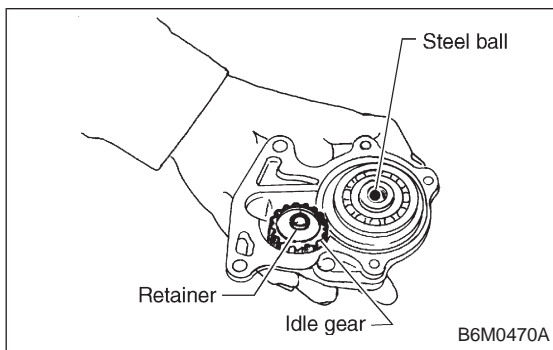

- 2) Assembling magnetic switch, clutch, and housing
To assemble, first install clutch to magnetic switch, then install idle gear, and finally install clutch.

CAUTION:

- Do not forget to install steel ball and coil spring to clutch.
- Attach bearing to idle gear beforehand.

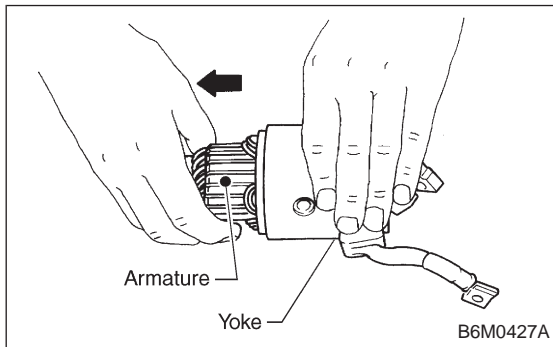

- 3) Installing armature to yoke

CAUTION:

Do not forget to put felt washer on armature shaft bearing.

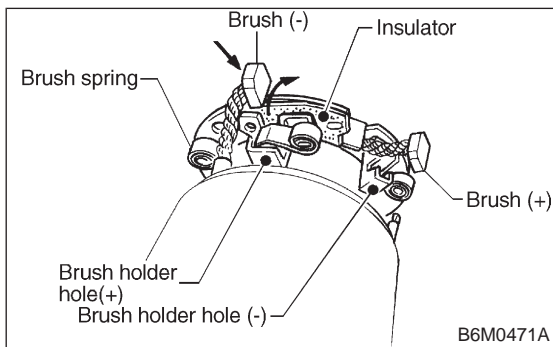

- 4) Installing brushes

Assemble brush holder to yoke as shown, then assemble two yoke-side brushes to brush holder.

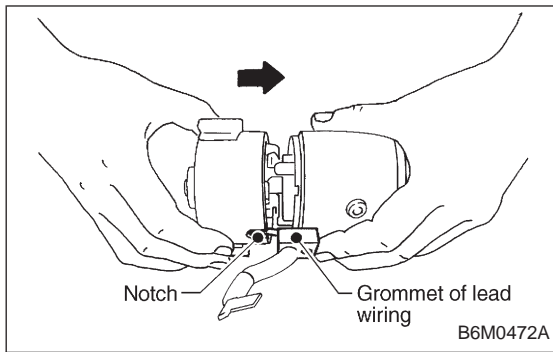

- 5) Installing end frame
When assembling end frame to yoke, align notched portion of end frame with lead wire grommet.

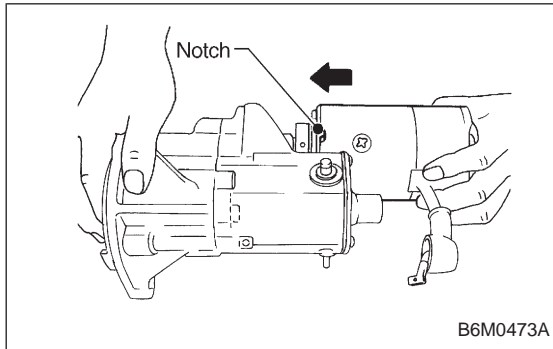

- 6) Installing yoke
When installing yoke to magnetic switch, align notch of yoke with protrusion of magnetic switch.

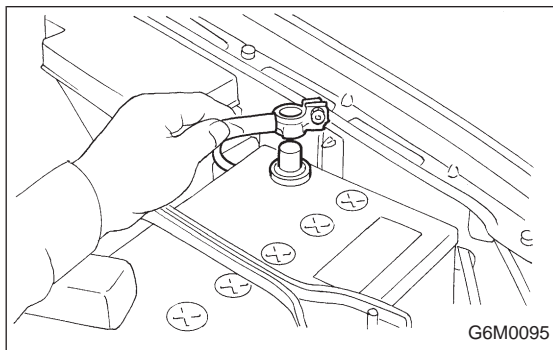

2. Generator

A: REMOVAL AND INSTALLATION

- 1) Disconnect battery ground cable.

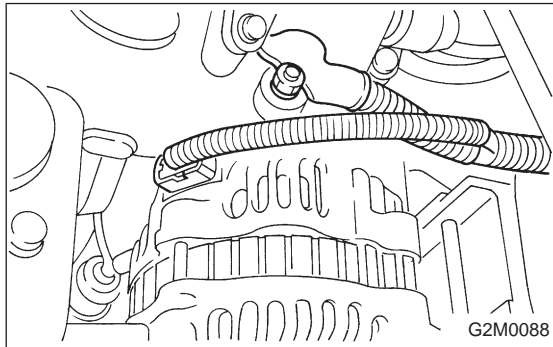

- 2) Disconnect connector and terminal from generator.

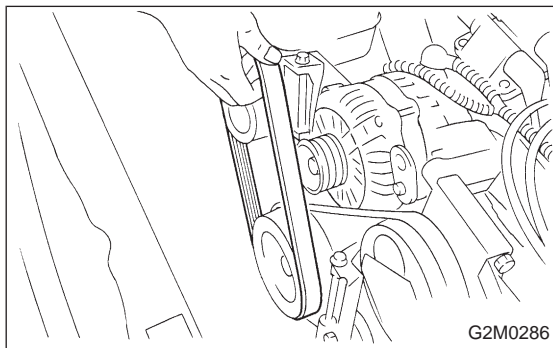

- 3) Remove V-belt cover.
4) Remove front side V-belt.

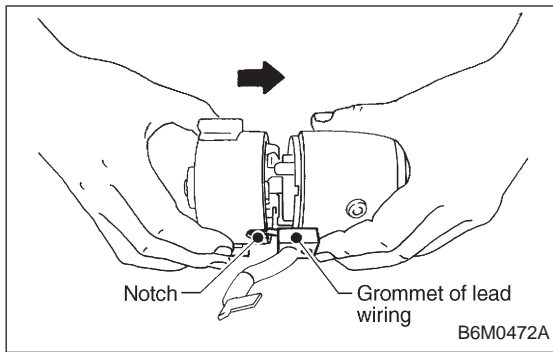

- 5) Installing end frame
When assembling end frame to yoke, align notched portion of end frame with lead wire grommet.

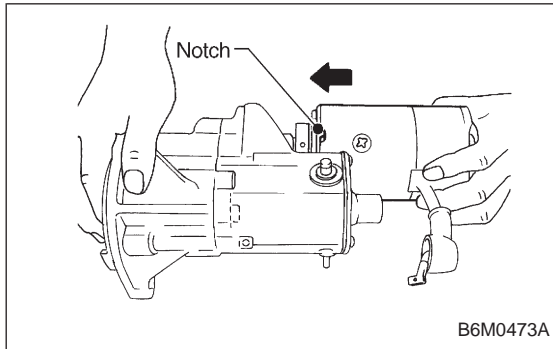

- 6) Installing yoke
When installing yoke to magnetic switch, align notch of yoke with protrusion of magnetic switch.

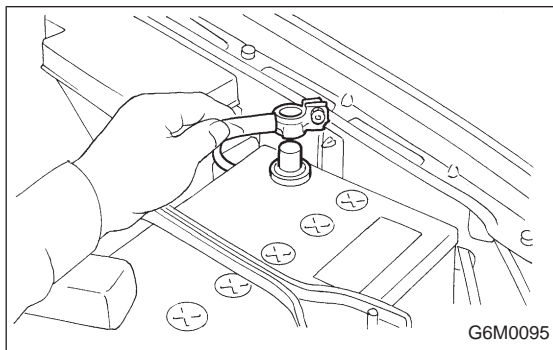

2. Generator

A: REMOVAL AND INSTALLATION

- 1) Disconnect battery ground cable.

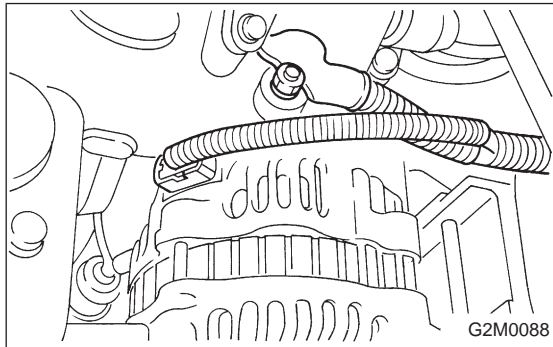

- 2) Disconnect connector and terminal from generator.

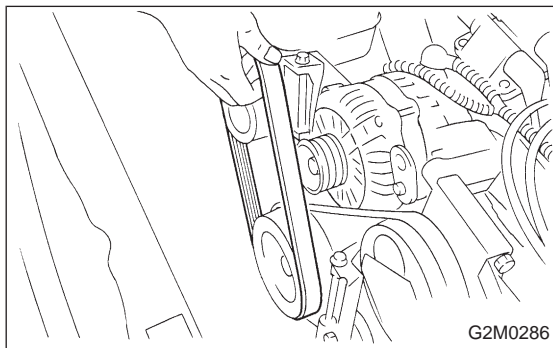

- 3) Remove V-belt cover.
4) Remove front side V-belt.

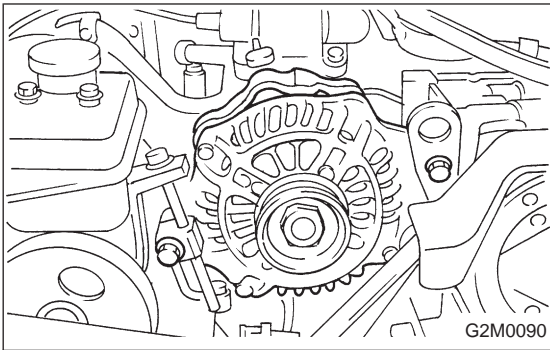

5) Remove bolts which install generator onto bracket.

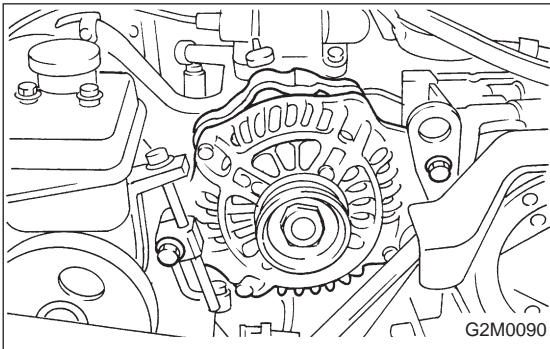

6) Installation is in the reverse order of removal.

CAUTION:
Check and adjust V-belt tension. <Ref. to 1-5 [01A0].>

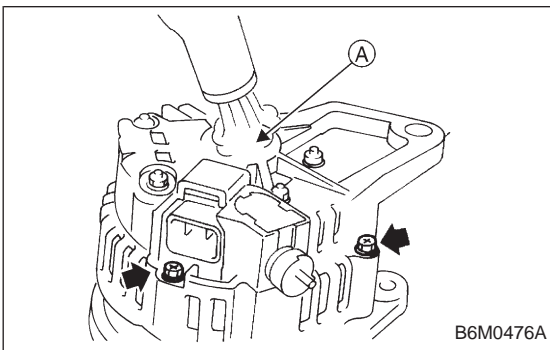

B: DISASSEMBLY

1) Heat the portion (A) of rear cover to 50°C (122°F) with heater drier.

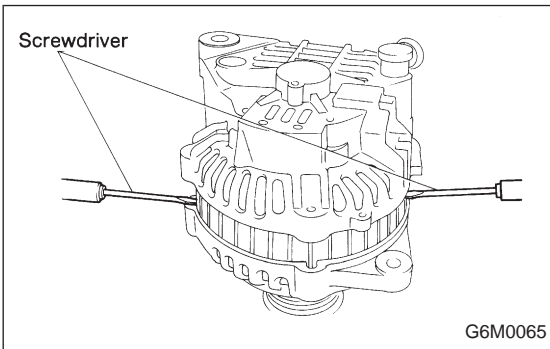

2) Remove the four through bolts. Then insert the tip of a flat-head screwdriver into the gap between the stator core and front bracket. Pry then apart to disassemble.

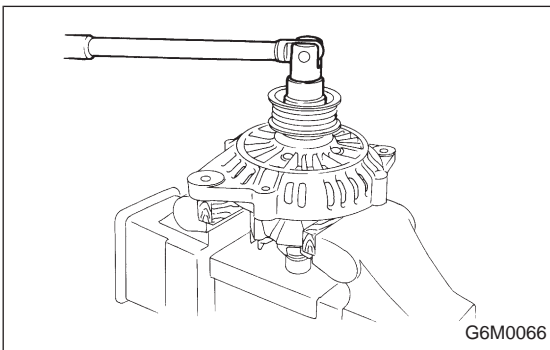

3) Hold rotor with a vise and remove pulley nut.

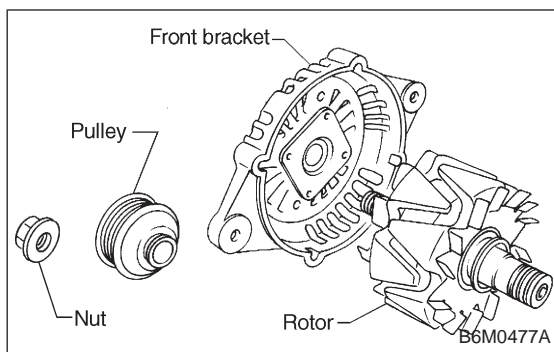
**CAUTION:**

When holding rotor with vise, insert aluminum plates or wood pieces on the contact surfaces of the vise to prevent rotor from damage.

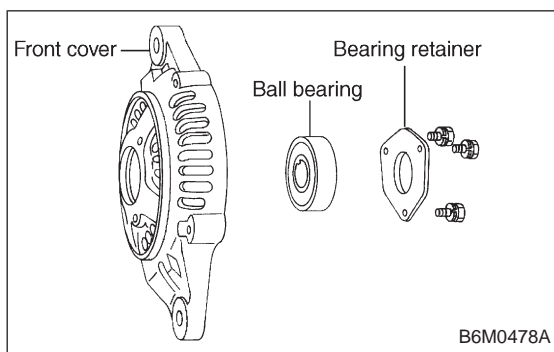

4) Remove rotor from front cover.

5) Remove three screws from front cover and then bearing retainer and ball bearing.

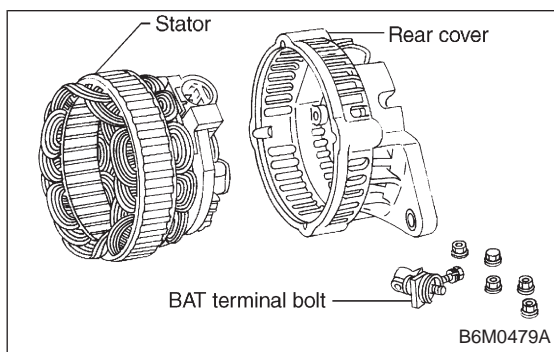

6) Remove bolt which secure battery terminal bolt, and remove rear cover. Remove nuts which secure diode plate, and remove stator and rear cover.

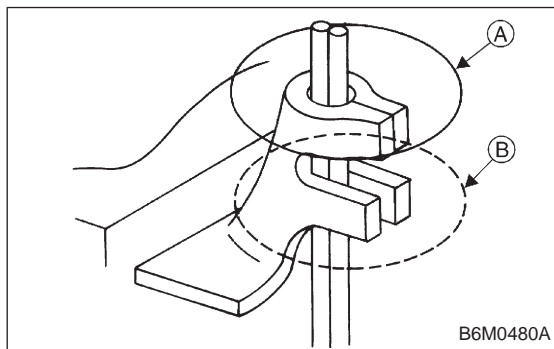

7) Separate diode plate from stator coil.

(1) Cut the connecting position (A) of stator coil to diode.

(2) Unsolder connection (B) and throughout the lead wire of stator coil.

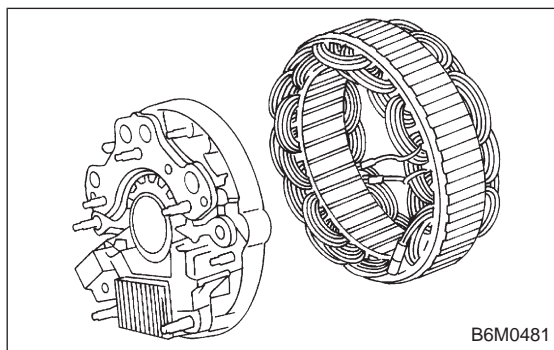

(3) Remove stator coil from diode plate.

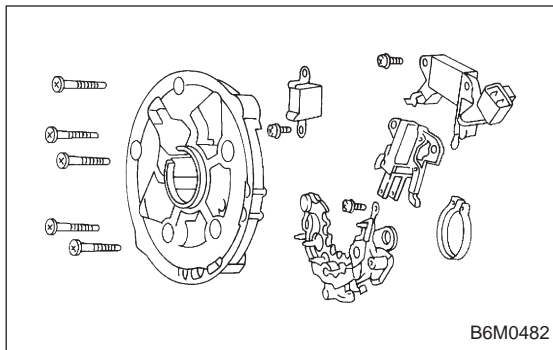

8) Remove bolts which secure IC regulator, diode and brush holder.

CAUTION:

Do not apply a shock or load to IC regulator cooling fins.

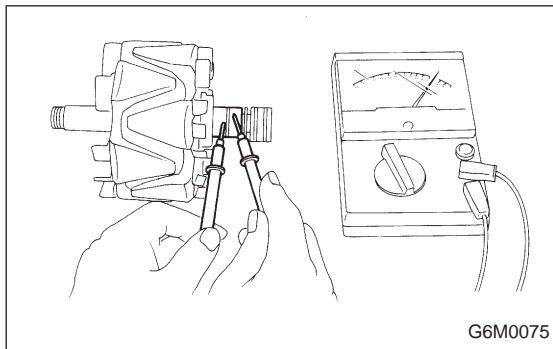

C: INSPECTION AND REPAIR

1. ROTOR

1) Slip ring surface

Inspect slip rings for contamination or any roughness of the sliding surface.

Clean or polish with #500 to #600 emery paper if defective.

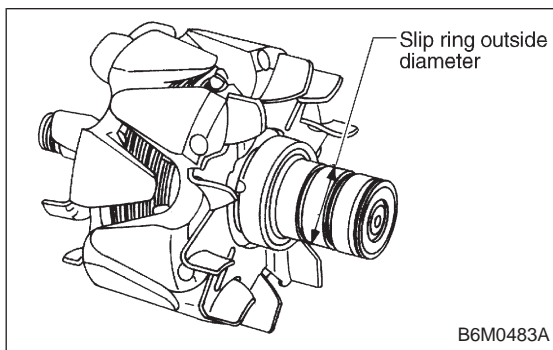

2) Slip ring outside diameter

Measure slip ring outside diameter. If slip ring is worn, replace rotor.

Slip ring outside diameter:

Standard

27 mm (1.06 in)

Limit

26 mm (1.02 in)

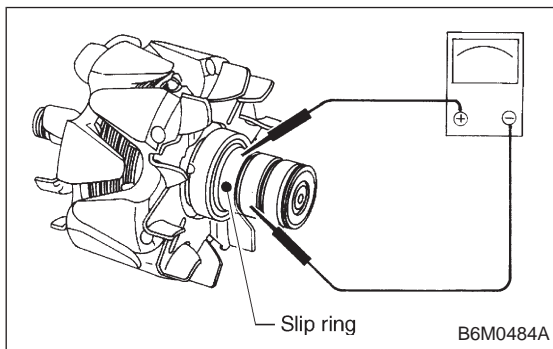

3) Continuity test

Check continuity between slip rings. If continuity does not exist, replace rotor.

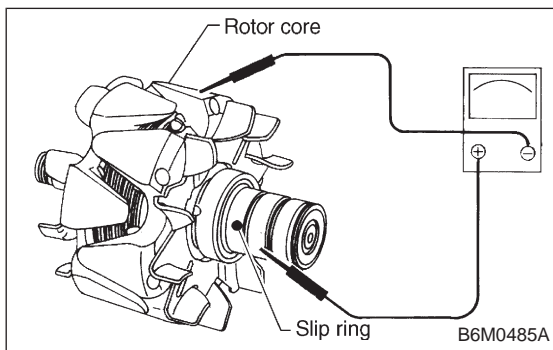

4) Insulation test

Check continuity between slip ring and rotor core or shaft. If continuity exists, replace rotor.

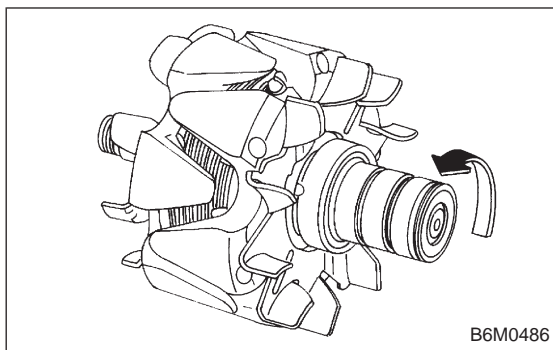

5) Ball bearing
Check rear ball bearing. Replace it if it is noisy or if rotor does not turn smoothly.

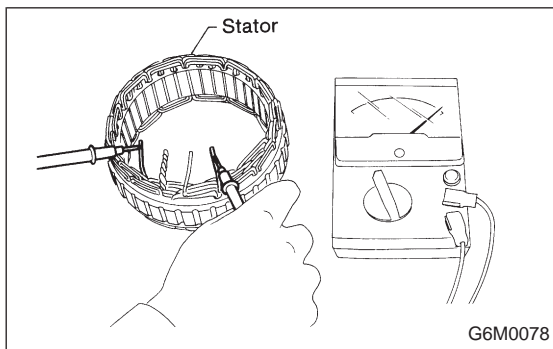

2. STATOR

1) Continuity test
Inspect stator coil for continuity between its terminals. When there is no continuity between individual terminals, cable is broken. Replace stator coil.

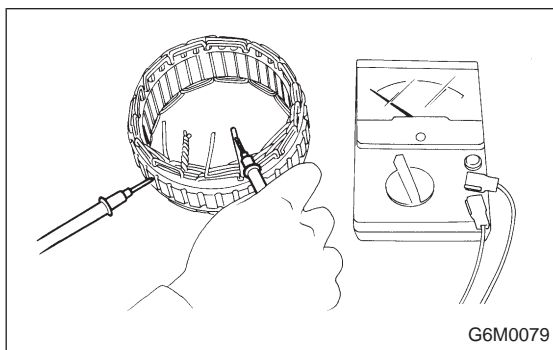

2) Insulation test
Inspect stator coil for continuity between stator core and each terminal. If there is continuity, replace stator coil.

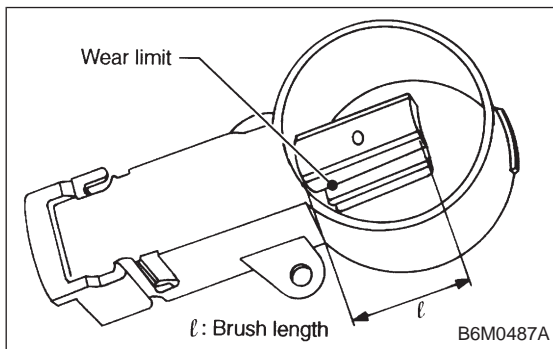

3. BRUSH

Measure brush length. If brush is worn, replace brush holder assembly.

Brush length (l):
Standard
20.5 mm (0.807 in)
Limit
1.5 mm (0.059 in)

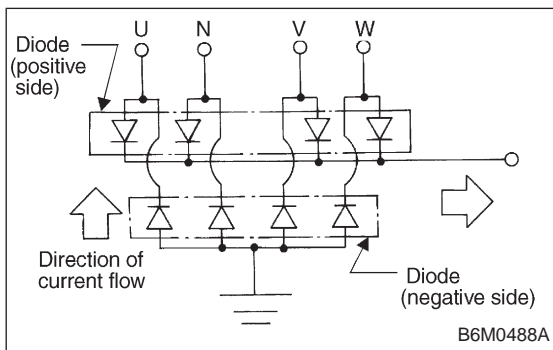

4. DIODE ASSEMBLY

The diode consists of eight diodes, four each being located on the positive and negative sides. The diode is necessary to restrict current flow to one direction. Check all diodes, for continuity. If any diode is faulty, replace diode assembly.

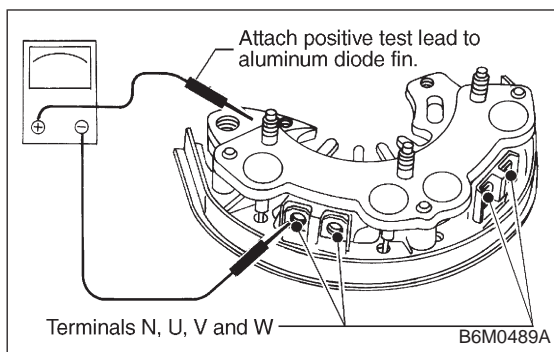

1) Diodes on “+” side

Continuity of proper diodes on “+” side

	BAT side	
Terminal N, U, V and W	(+)	(-)
(+)	—	Continuity must not exist.
(-)	Continuity must exist.	—

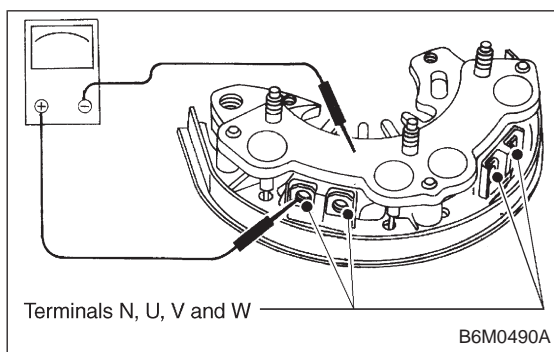

2) Diodes on “-” side

Continuity of proper diodes on “-” side

	“E” side	
Terminal N, U, V and W	(+)	(-)
(+)	—	Continuity must exist.
(-)	Continuity must not exist.	—

CAUTION:

Never use a high tension insulation tester, such as a meggar as it will damage diodes with its high tension.

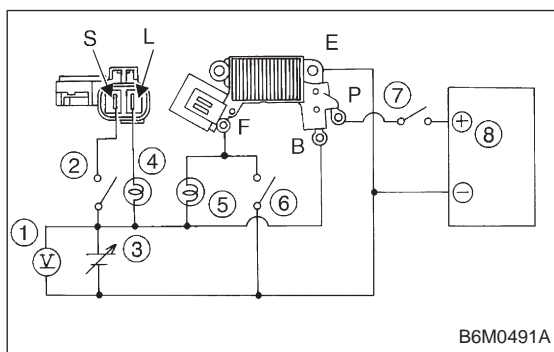

5. IC REGULATOR

1) Compose a circuit diagram as shown in figure.

- ① Voltage meter: 0 to 30 V
- ② Switch 1
- ③ Variable DC power supply: Variable 0 to 20 V, 1 A or more
- ④ Lamp 2
- ⑤ Lamp 1
- ⑥ Switch 3
- ⑦ Switch 2
- ⑧ Plus generator: Power supply 5 to 30 V, 1 kHz

2) Check operation as shown in chart below.

No.	Switch operation			Value of voltage meter	Lamp operation		Remarks
	1	2	3		1	2	
1	ON	OFF	OFF	12 V	DIM	ON	Check initial excitation.
2	ON	ON	OFF	12 V	ON or BLINK	OFF	Check total excitation.
3	ON	ON	OFF	16 V	OFF or DIM-BLINK	OFF	When value of voltage meter is between 12 V and 16 V.
4	OFF	ON	OFF	12 V	ON or BLINK	ON	Check connection for S and B terminals.
5	OFF	ON	ON	18 V	ON	ON	Check for over loading of voltage.

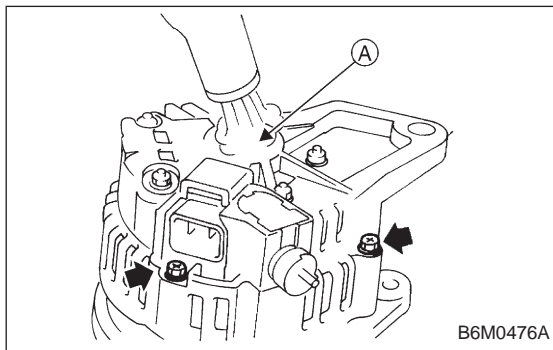
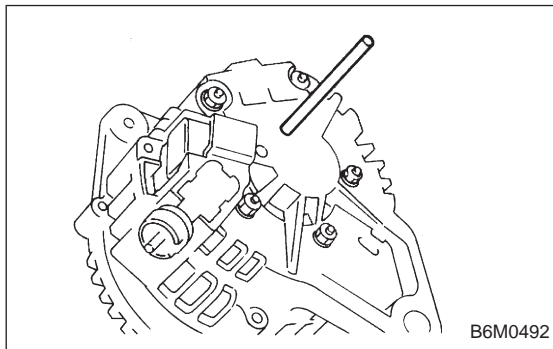
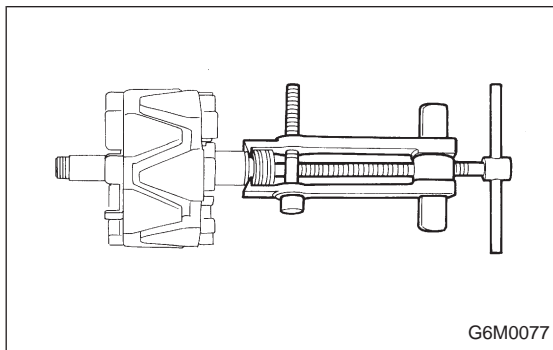

D: ASSEMBLY

Assembly is in the reverse order of disassembly procedures.

CAUTION:

- When disassembling generator, replace rear ball bearing.
- When soldering starter coil to diode, do not touch lead wire with solder for more than 5 seconds.

- Before installing rear cover, insert pin from outside of rear cover so that holds brush. After installing rear cover, remove pin.

- When installing rear cover, heat portion (A) to 50°C (122°F) with heater drier.

3. Spark Plug

A: REMOVAL AND INSTALLATION

CAUTION:

All spark plugs installed on an engine, must be of the same heat range.

Spark plug:

CHAMPION: RC10YC4

(Alternate)

NGK: BKR6E-11

NIPPONDENSO: K20PR-U11

- 1) Remove spark plug cords by pulling boot, not cord itself.
- 2) Remove spark plugs.
- 3) When installing spark plugs on cylinder head, use spark plug wrench.

Tightening torque (Spark plug):

$20.6 \pm 2.9 \text{ N}\cdot\text{m}$ ($2.10 \pm 0.30 \text{ kg}\cdot\text{m}$, $15.19 \pm 2.14 \text{ ft}\cdot\text{lb}$)

CAUTION:

The above torque should be only applied to new spark plugs without oil on their threads.

In case their threads are lubricated, the torque should be reduced by approximately 1/3 of the specified torque in order to avoid their over-stressing.

- 4) Connect spark plug cords.

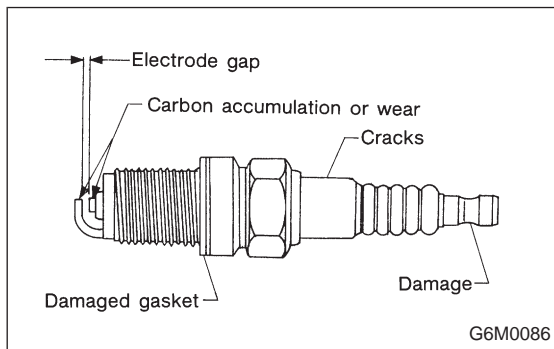

B: INSPECTION

Check electrodes and inner and outer porcelain of plugs, noting the type of deposits and the degree of electrode erosion.

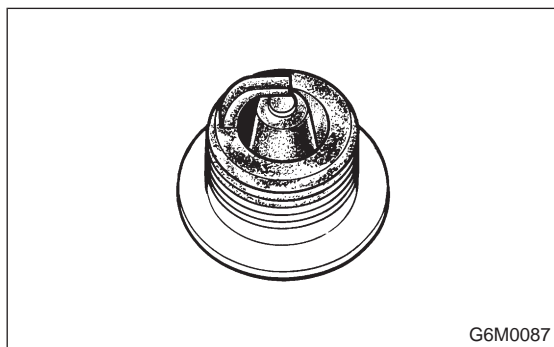

- 1) Normal

Brown to grayish-tan deposits and slight electrode wear indicate correct spark plug heat range.

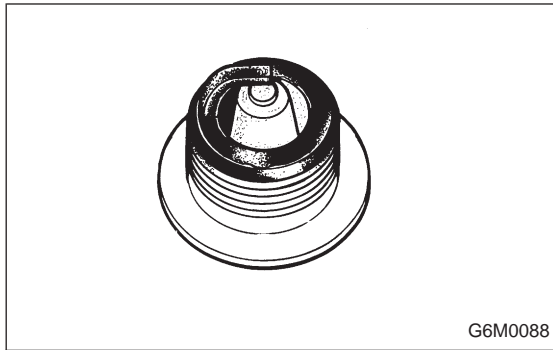

2) Carbon fouled

Dry fluffy carbon deposits on insulator and electrode are mostly caused by slow speed driving in city, weak ignition, too rich fuel mixture, dirty air cleaner, etc.

It is advisable to replace with plugs having hotter heat range.

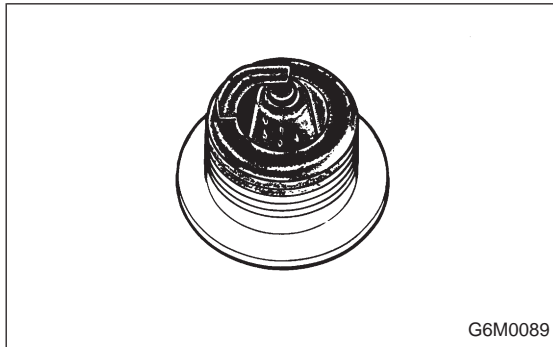

3) Oil fouled

Wet black deposits show excessive oil entrance into combustion chamber through worn rings and pistons or excessive clearance between valve guides and stems. If same condition remains after repair, use a hotter plug.

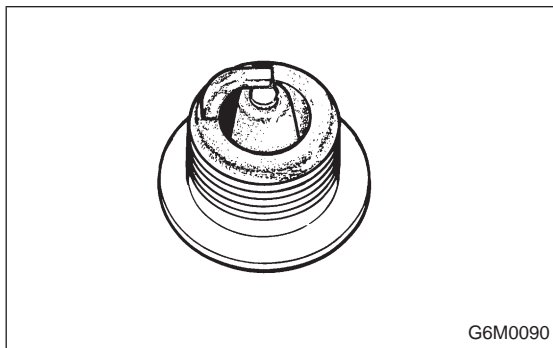

4) Overheating

White or light gray insulator with black or gray brown spots and bluish burnt electrodes indicate engine overheating. Moreover, the appearance results from incorrect ignition timing, loose spark plugs, wrong selection of fuel, hotter range plug, etc. It is advisable to replace with plugs having colder heat range.

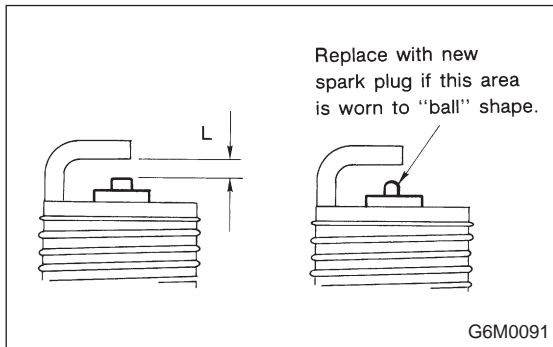
**C: CLEANING AND REGAPPING**

Clean spark plugs in a sand blast type cleaner.

Avoid excessive blasting. Clean and remove carbon or oxide deposits, but do not wear away porcelain.

If deposits are too stubborn, discard plugs.

After cleaning spark plugs, recondition firing surface of electrodes with file. Then correct the spark plug gap using a gap gauge.

Spark plug gap: L

1.0 — 1.1 mm (0.039 — 0.043 in)

D: REMOVAL AND INSTALLATION (2500 cc EXCEPT OUTBACK MODEL)**CAUTION:**

All spark plugs installed on an engine, must be of the same heat range.

Spark plug:

NGK: PFR5B-11

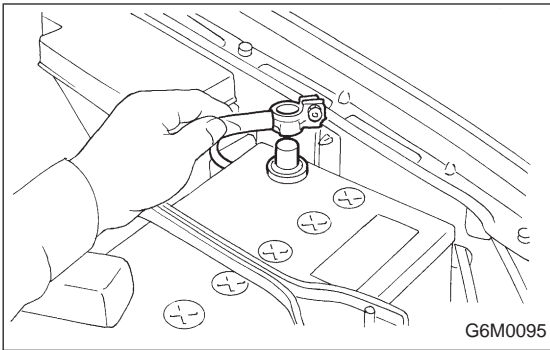

1. #1 SPARK PLUG

- 1) Disconnect battery ground cable.

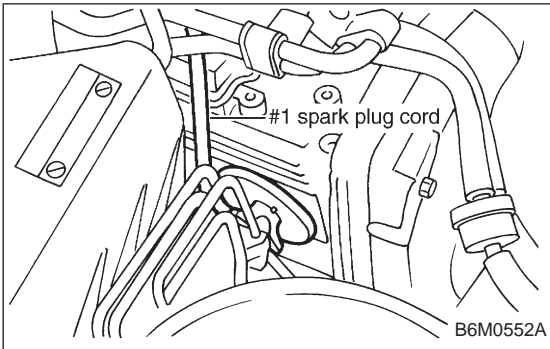

- 2) Remove #1 spark plug cord by pulling boot, not cord itself.

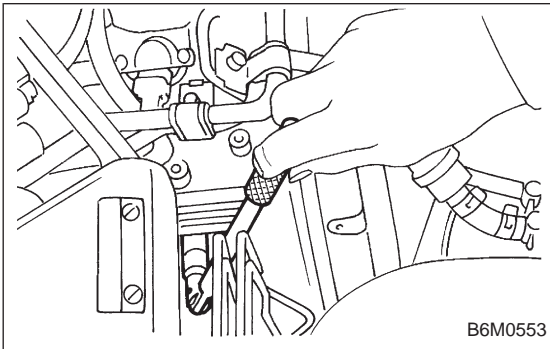

- 3) Remove spark plug with the spark plug socket.

- 4) Installation is in the reverse order of removal.

Tightening torque (Spark plug):

20.6±2.9 N·m (2.10±0.30 kg·m, 15.19±2.14 ft·lb)

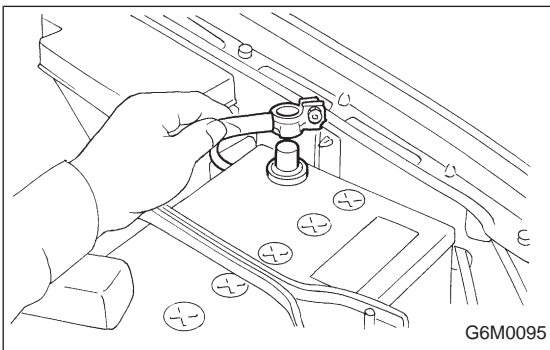

2. #2 SPARK PLUG

- 1) Disconnect battery ground cable.

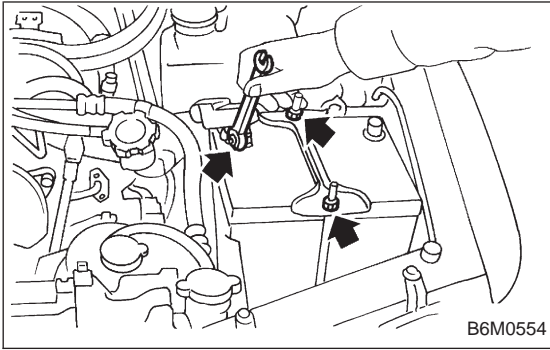

2) Remove battery.

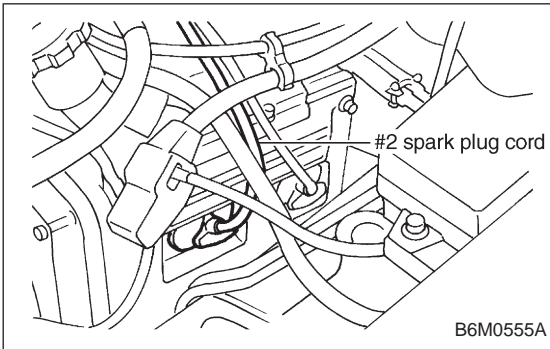

3) Remove #2 spark plug cord by pulling boot, not cord itself.

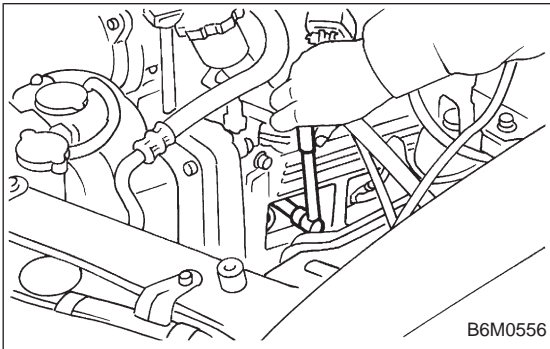

4) Remove spark plug with the spark plug socket.

5) Installation is in the reverse order of removal.

Tightening torque (Spark plug):

20.6 ± 2.9 N·m (2.10 ± 0.30 kg·m, 15.19 ± 2.14 ft·lb)

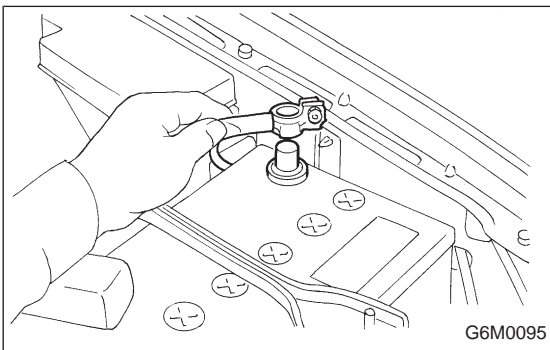

3. #3 SPARK PLUG

1) Disconnect battery ground cable.

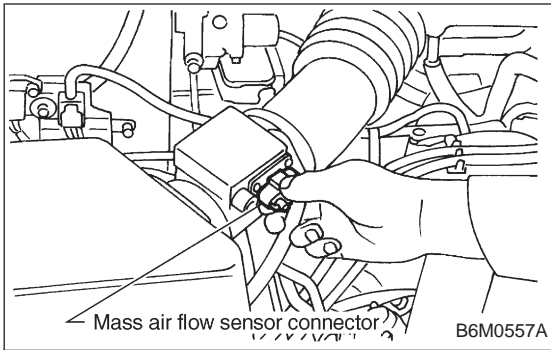

- 2) Disconnect mass air flow sensor connector.
- 3) Remove four clips securing air cleaner upper cover.

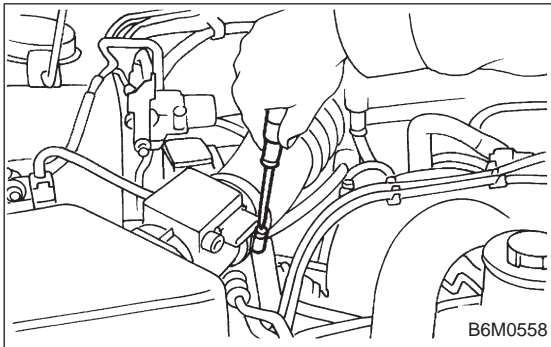

- 4) Loosen the clamp screw and separate air cleaner upper cover from air intake duct.
- 5) Remove air cleaner element.

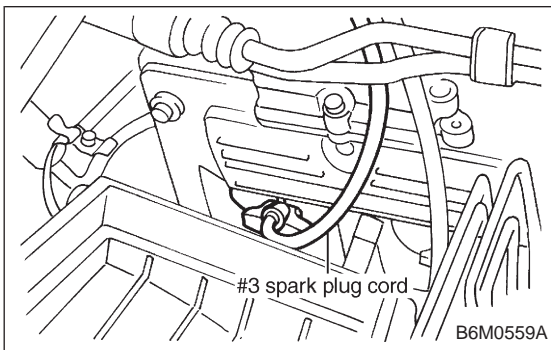

- 6) Remove #3 spark plug cord by pulling boot, not cord itself.

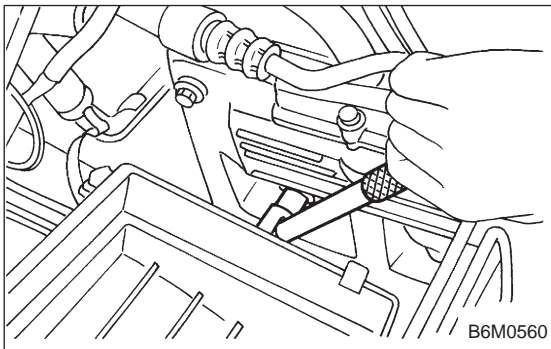

- 7) Remove spark plug with the spark plug socket.

- 8) Installation is in the reverse order of removal.

Tightening torque (Spark plug):

20.6±2.9 N·m (2.10±0.30 kg·m, 15.19±2.14 ft·lb)

3. Spark Plug

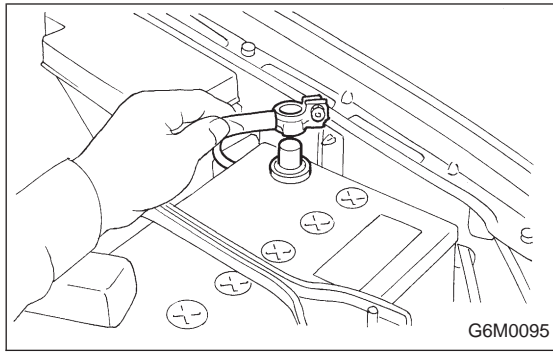

4. #4 SPARK PLUG

1) Disconnect battery ground cable.

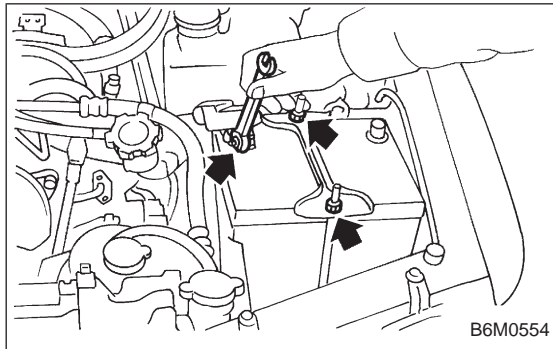

2) Remove battery.

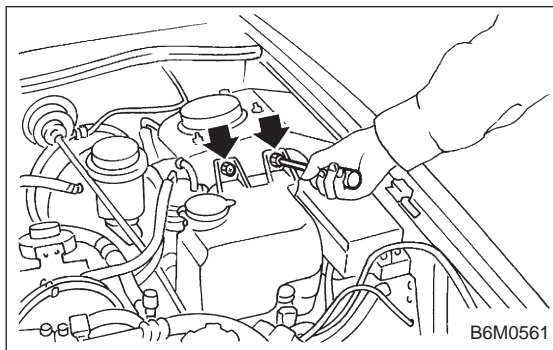

3) Remove washer tank mounting bolts.

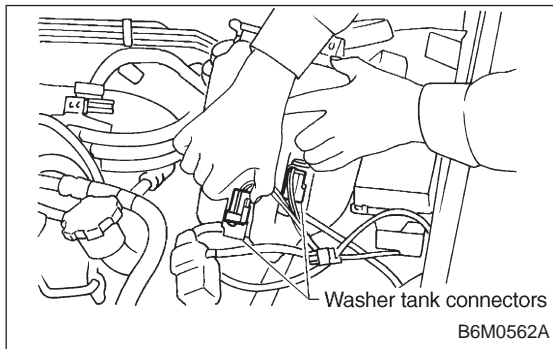

4) Disconnect washer tank connectors.

CAUTION:
Do not disconnect washer tank hoses as washer fluid will leak out from washer tank.

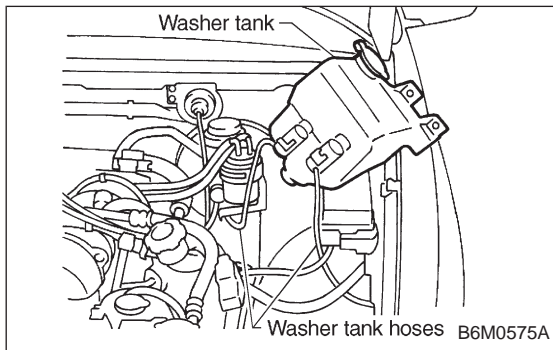

5) Move washer tank upward.

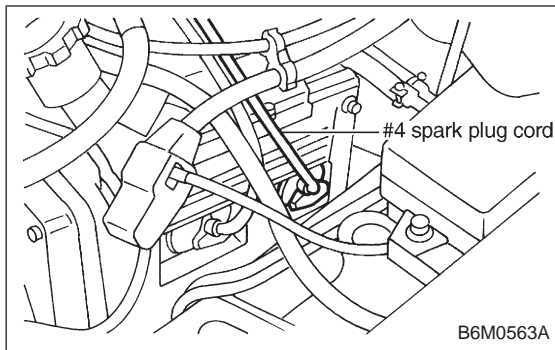

6) Remove #4 spark plug cord by pulling boot, not cord itself.

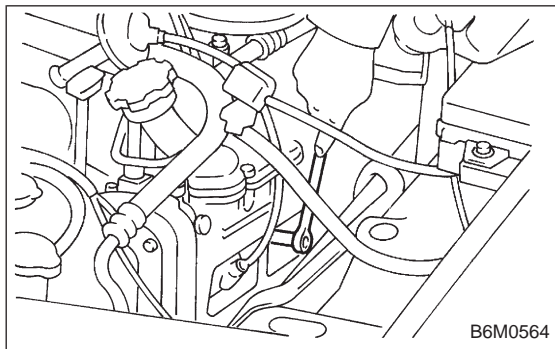

7) Remove spark plug with the spark plug socket.

8) Installation is in the reverse order of removal.

Tightening torque (Spark plug):

20.6 ± 2.9 N·m (2.10 ± 0.30 kg·m, 15.19 ± 2.14 ft·lb)

CAUTION:

The above torque should be only applied to new spark plugs without oil on their threads.

In case their threads are lubricated, the torque should be reduced by approximately 1/3 of the specified torque in order to avoid over-stressing.

E: REMOVAL (2500 cc OUTBACK MODEL)

CAUTION:

All spark plugs installed on an engine, must be of the same heat range.

Spark plug:

NGK: PFR5B-11

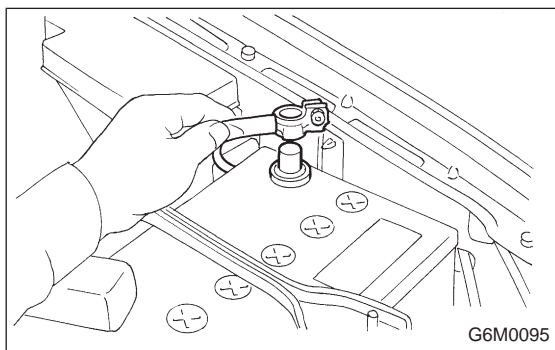

1. #1 SPARK PLUG

1) Disconnect battery ground cable.

3. Spark Plug

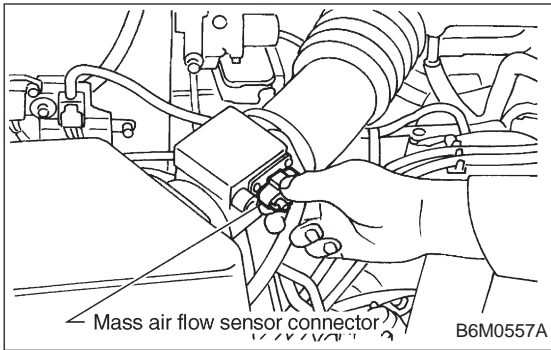

- 2) Disconnect mass air flow sensor connector.
- 3) Remove four clips securing air cleaner upper cover.

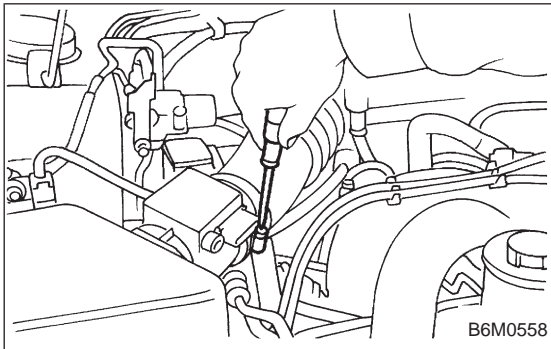

- 4) Loosen the clamp screw and separate air cleaner upper cover from air intake duct.

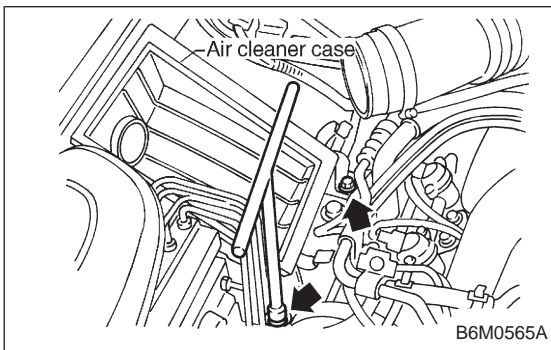

- 5) Remove air cleaner element and air cleaner case.

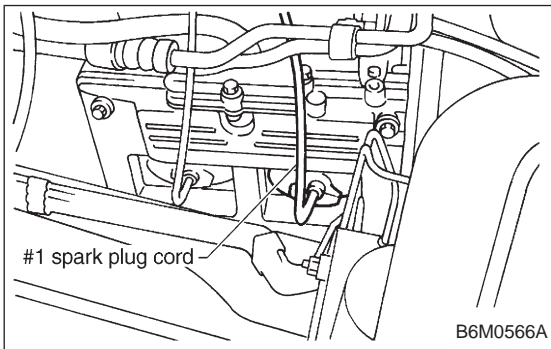

- 6) Remove #1 spark plug cord by pulling boot, not cord itself.

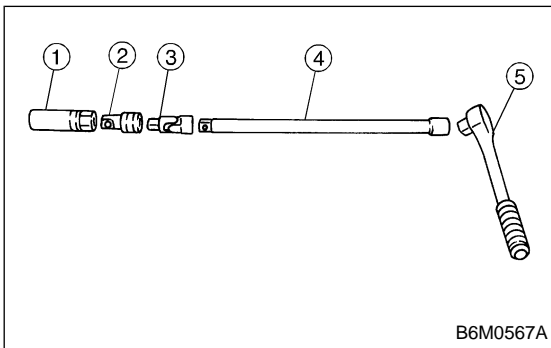

- 7) After connecting ① spark plug socket, ② extension and ③ Universal Joint to each other, securely set them over the spark plug in cylinder head.

- 8) Cover ABS pipes with rag to prevent damage.

- ① Spark plug socket 16 mm (5/8 in)
- ② Extension
- ③ Universal Joint
- ④ Extension
- ⑤ Ratchet

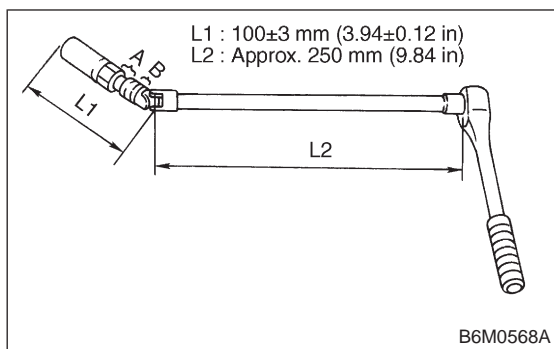

NOTE:

- Length L1 is important in making for easy removal.
- It may be necessary to wrap points A and B with vinyl tape to prevent them separating while working. If they do separate, spark plug socket is left on the spark plug and it is very difficult to remove.
- An approximately 250 mm (9.84 in) long extension is recommended to be connected to ratchet.
- For spark plug socket, extension and Universal Joint, it is recommended to use the following tools.

Spark plug socket : PROTO 5020-50

Extension : SNAP-ON FX1

Universal Joint : SNAP-ON FU80B

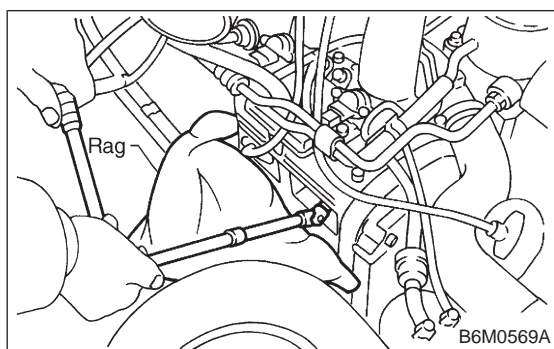

- 9) Set ④ extension and ⑤ ratchet in turn onto the connected tools in plug hole, and remove spark plug using them.

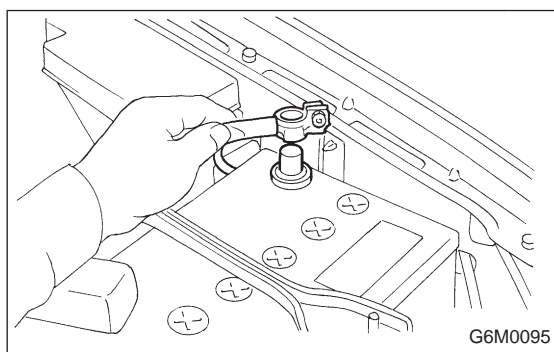

2. #2 SPARK PLUG

- 1) Disconnect battery ground cable.

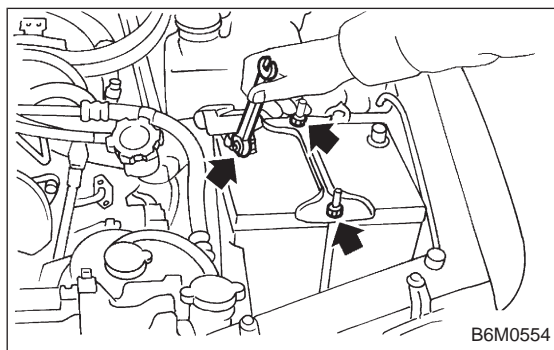

- 2) Remove battery.

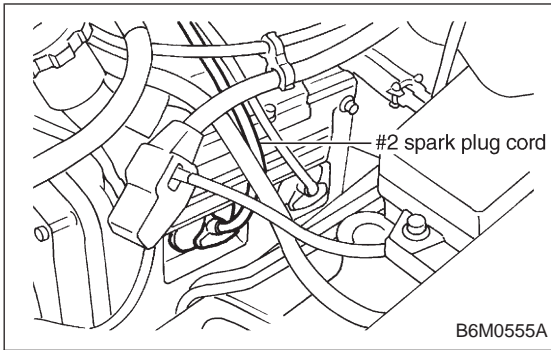

- 3) Remove #2 spark plug cord by pulling boot, not cord itself.
- 4) For subsequent procedures, refer to the procedure for #1 spark plug. <Ref. to 6-1 [W3E1].>

CAUTION:

When removing spark plug, cover the ATF cooling pipes with a rag to prevent damage.

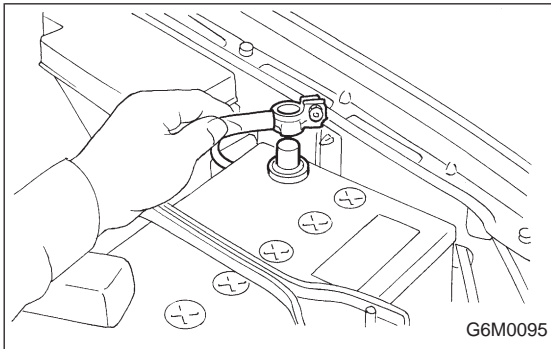
**3. #3 SPARK PLUG**

- 1) Disconnect battery ground cable.

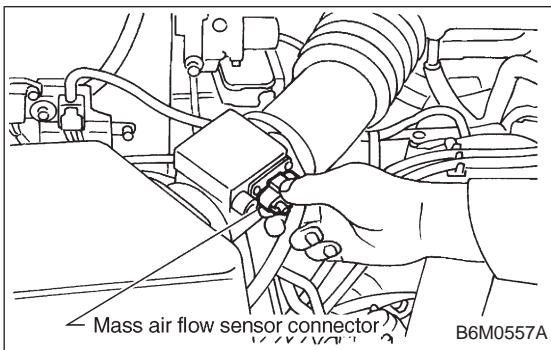

- 2) Disconnect mass air flow sensor connector.
- 3) Remove four clips securing air cleaner upper cover.

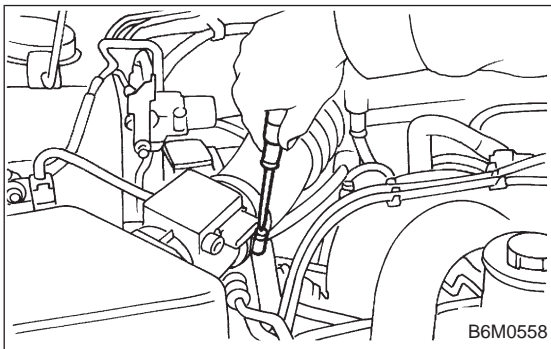

- 4) Loosen the clamp screw and separate air cleaner upper cover from air intake duct.

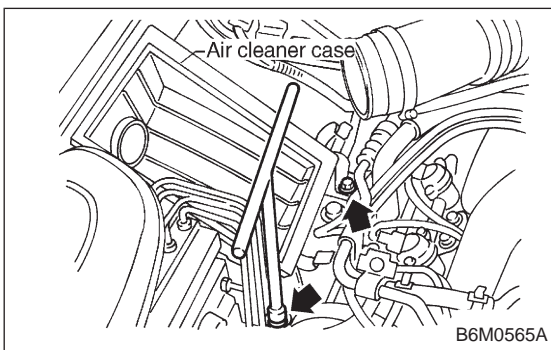

- 5) Remove air cleaner element and air cleaner case.

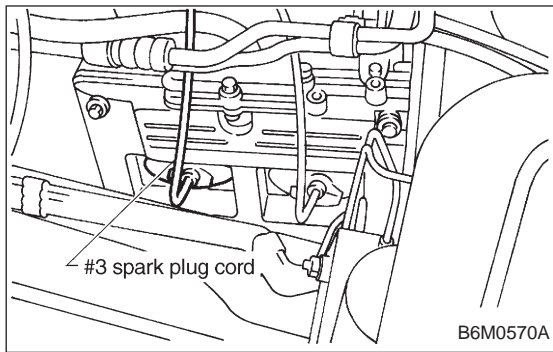

- 6) Remove #3 spark plug cord by pulling boot, not cord itself.
- 7) For subsequent procedures, refer to the procedure for #1 spark plug. <Ref. to 6-1 [W3E1].>

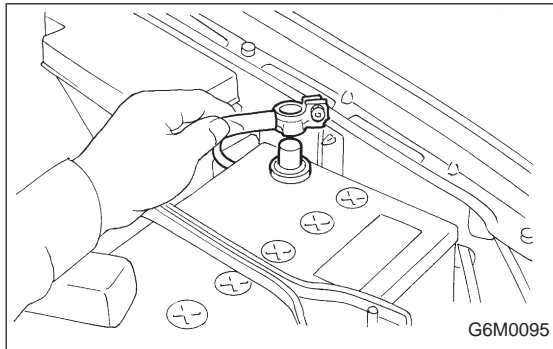

4. #4 SPARK PLUG

- 1) Disconnect battery ground cable.

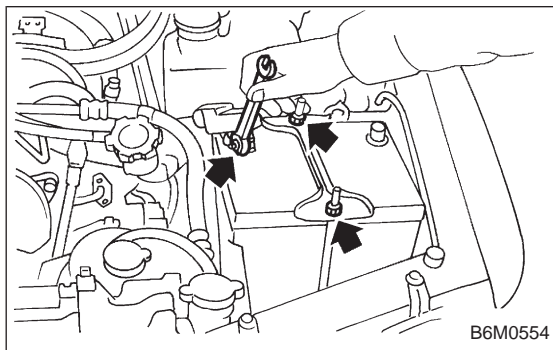

- 2) Remove battery.

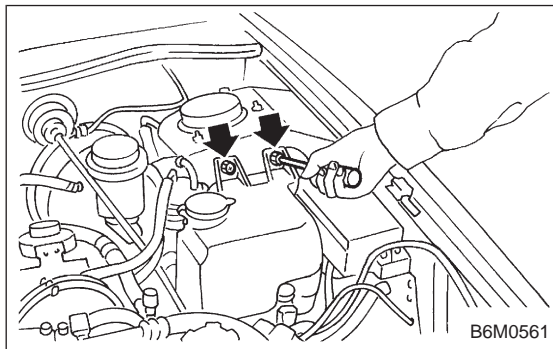

- 3) Remove washer tank mounting bolts.

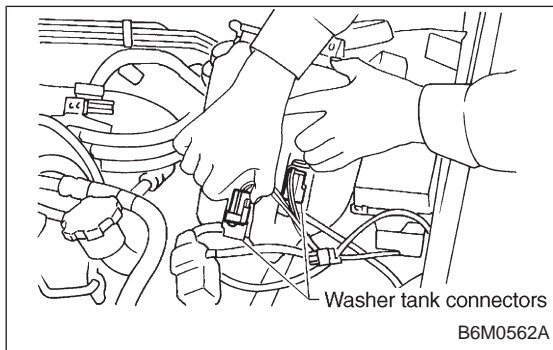

- 4) Disconnect washer tank connectors.

CAUTION:

Do not disconnect washer tank hoses as washer fluid will leak out from washer tank.

3. Spark Plug

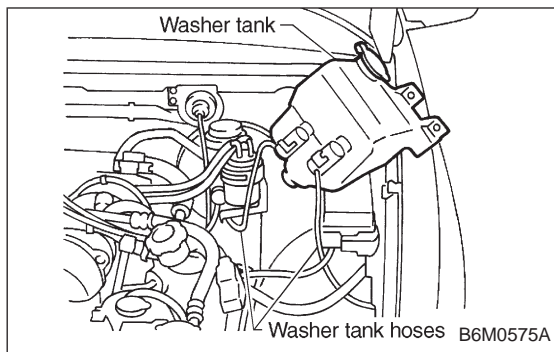

5) Move washer tank upward.

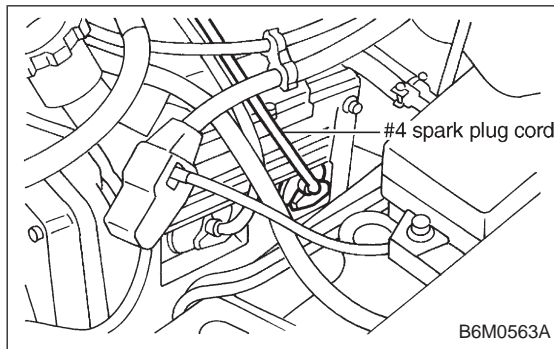

6) Remove #4 spark plug cord by pulling boot, not cord itself.

7) For subsequent procedures, refer to the procedure for #1 spark plug. <Ref. to 6-1 [W3E1].>

CAUTION:

When removing spark plug, cover the ATF cooling pipes with a rag to prevent damage.

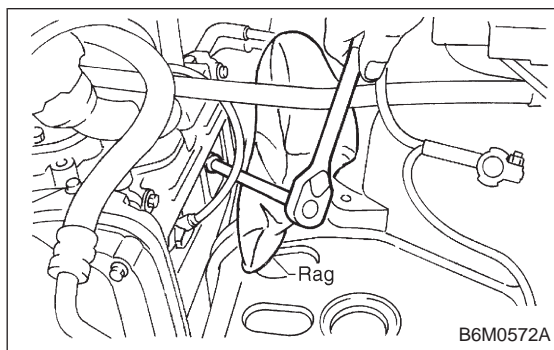
**NOTE:**

For easier removal of spark plug, diagonally insert the tools from the direction of battery stand into plug hole as shown in figure.

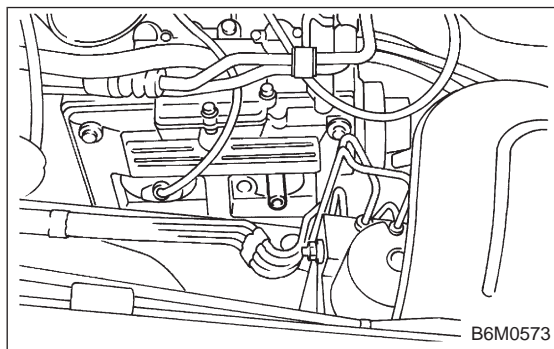
**F: INSTALLATION (2500 cc OUTBACK MODEL)****1. #1 SPARK PLUG**

1) After setting spark plug in spark plug socket, connect the spark plug socket, extension and Universal Joint to each other. <Ref. to 6-1 [W3E1].>

2) Screw spark plug into cylinder head using the connected tools above mentioned. At this point, it is necessary to support the rear end of the tools with fingertips.

3) When spark plug is screwed in two or three turns, temporarily disconnect the tools connected in step 1) above.

4) Confirm that spark plug is screwed into the cylinder head properly by touching it with finger. If it is difficult to reach it by hand, confirm its condition by using mirror and suchlike.

5) Cover ABS pipes with rag to prevent damage.

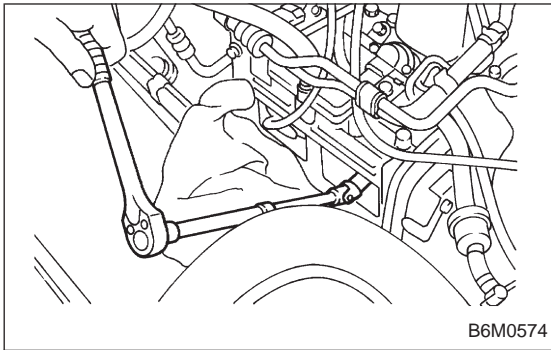

- 6) Re-insert the tools disconnected in step 3) into plug hole, and set them again over the spark plug.
- 7) Set extension and ratchet in turn onto the connected tools in plug hole, and tighten spark plug to the specified torque.

Tightening torque (spark plug):

$20.6 \pm 2.9 \text{ N}\cdot\text{m}$ ($2.10 \pm 0.30 \text{ kg}\cdot\text{m}$, $15.19 \pm 2.14 \text{ ft}\cdot\text{lb}$)

CAUTION:

The above torque should be only applied to new spark plugs without oil on their threads.

In case their threads are lubricated, the torque should be reduced by approximately 1/3 of the specified torque in order to avoid over-stressing.

- 8) The subsequent procedures are in reverse order of #1 spark plug removal. <Ref. to 6-1 [W3E1].>

2. #2 SPARK PLUG

CAUTION:

When installing spark plug, cover the ATF cooling pipes with a rag to prevent damage.

- 1) Carry out steps 1), 2), 3), 4), 6) and 7) of #1 spark plug installation procedure. <Ref. to 6-1 [W3F1].>
- 2) Proceed in reverse order of #2 spark plug removal. <Ref. to 6-1 [W3E2].>

3. #3 SPARK PLUG

- 1) Carry out steps 1) through 7) of #1 spark plug installation procedure. <Ref. to 6-1 [W3F1].>
- 2) Proceed in reverse order of #3 spark plug removal. <Ref. to 6-1 [W3E3].>

4. #4 SPARK PLUG

CAUTION:

When installing spark plug, cover the ATF cooling pipes with a rag to prevent damage.

- 1) Carry out steps 1), 2), 3), 4), 6) and 7) of #1 spark plug installation procedure. <Ref. to 6-1 [W3F1].>
- 2) Proceed in reverse order of #4 spark plug removal. <Ref. to 6-1 [W3E4].>

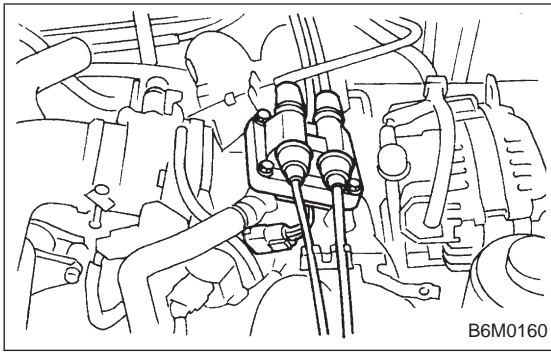

4. Ignition Coil

A: REMOVAL AND INSTALLATION

1. EXCEPT 2200 cc MODEL

- 1) Disconnect battery ground cable.
- 2) Disconnect connector from ignition coil.
- 3) Remove ignition coil.
- 4) Installation is in the reverse order of removal.

CAUTION:

Be sure to connect wires to their proper positions.
Failure to do so will damage unit.

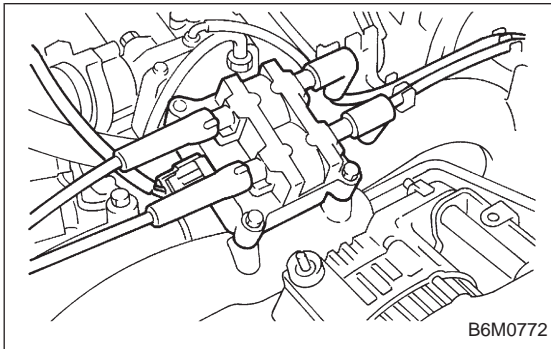

2. 2200 cc MODEL

- 1) Disconnect battery ground cable.
- 2) Disconnect connector from ignition coil.
- 3) Disconnect spark plug cords from ignition coil.
- 4) Remove ignition coil.
- 5) Installation is in the reverse order of removal.

CAUTION:

Be sure to connect wires to their proper positions.
Failure to do so will damage unit.

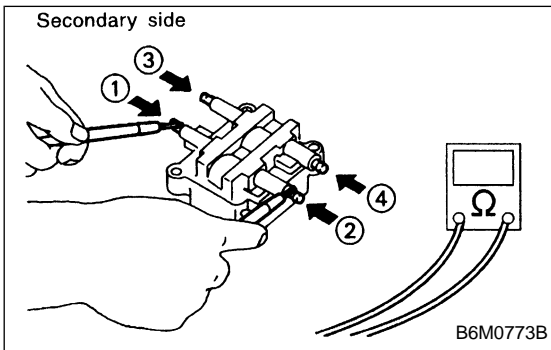
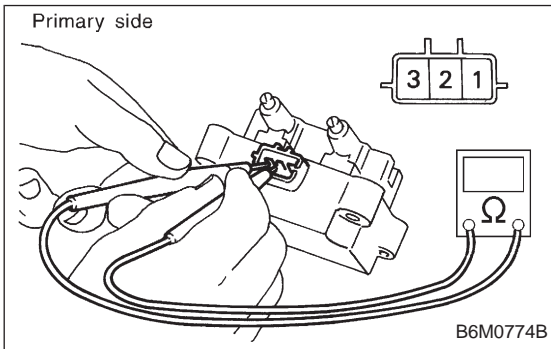

B: INSPECTION

Using accurate tester, inspect the following items, and replace if defective.

- 1) Primary resistance
- 2) Secondary coil resistance

CAUTION:

If the resistance is extremely low, this indicates the presence of a short-circuit.

Specified resistance:

[Primary side]

Between terminal No. 1 and No. 2

Between terminal No. 2 and No. 3

0.73 Ω±10%

[Secondary side]

Between ① and ②

Between ③ and ④

12.8 kΩ±15%

- 3) Insulation between primary terminal and case: 10 MΩ or more.

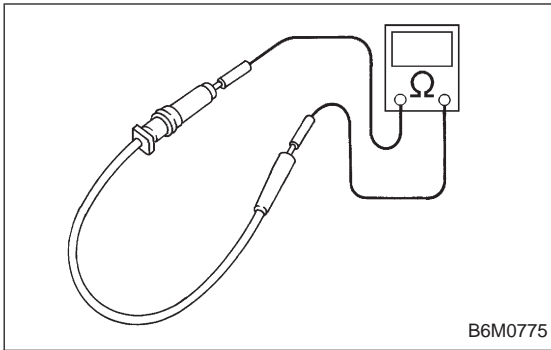

5. Spark Plug Cord

A: INSPECTION

Check for:

- 1) Damage to cords, deformation, burning or rust formation of terminals
- 2) Resistance values of cords

Resistance value:

5.12 — 12.34 k Ω

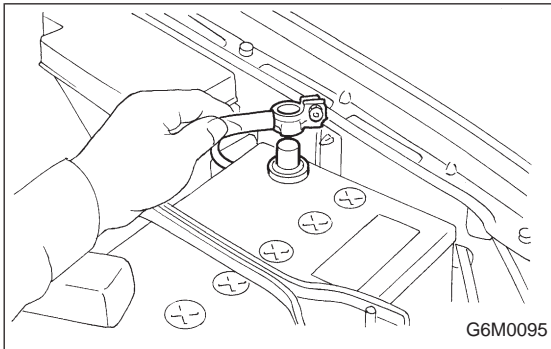

6. Ignitor

A: REMOVAL AND INSTALLATION

- 1) Disconnect battery ground cable.
- 2) Disconnect connector from ignitor.
- 3) Remove screws which hold ignitor onto body.
- 4) Installation is in the reverse order of removal.

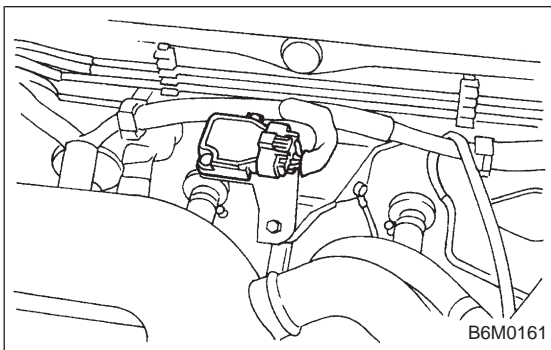

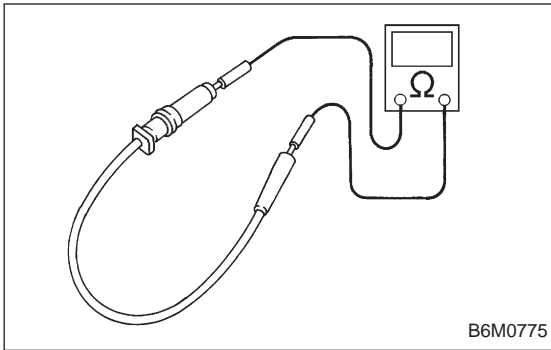

5. Spark Plug Cord

A: INSPECTION

Check for:

- 1) Damage to cords, deformation, burning or rust formation of terminals
- 2) Resistance values of cords

Resistance value:

5.12 — 12.34 kΩ

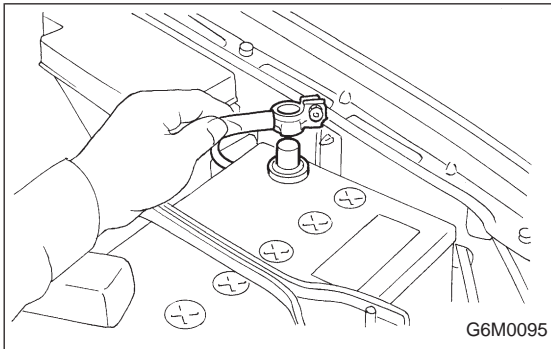

6. Ignitor

A: REMOVAL AND INSTALLATION

- 1) Disconnect battery ground cable.
- 2) Disconnect connector from ignitor.
- 3) Remove screws which hold ignitor onto body.
- 4) Installation is in the reverse order of removal.

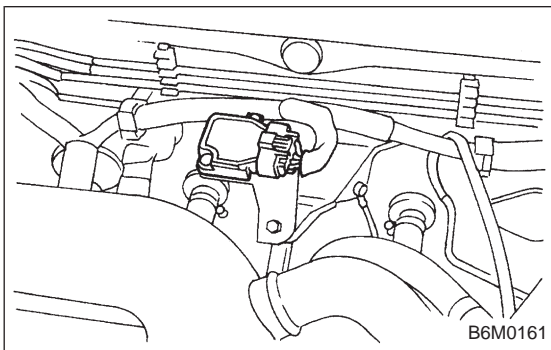

1. Starter

Trouble		Probable cause
Starter does not start.	Magnet switch does not operate. (no clicks are heard.)	Magnet switch poor contact or discontinuity of pull-in coil circuit
		Improper sliding of magnet switch plunger
	Magnet switch operates. (clicks are issued.)	Poor contact of magnet switch's main contact point
		Layer short of armature
		Contaminants on armature commutator
		High armature mica
		Improper grounding of yoke field coil
		Insufficient carbon brush length
	Insufficient brush spring pressure	
Starter starts but does not crank engine.	Failure of pinion gear to engage ring gear	Worn pinion teeth
		Improper sliding of overrunning clutch
		Improper adjustment of stud bolt
	Clutch slippage	Faulty clutch roller spring
Starter starts but engine cranks too slowly.		Poor contact of magnet switch's main contact point
		Layer short of armature
		Discontinuity, burning or wear of armature commutator
		Poor grounding of yoke field coil
		Insufficient brush length
		Insufficient brush spring pressure
	Abnormal brush wear	
Starter overruns.		Magnet switch coil is a layer short.

2. Generator

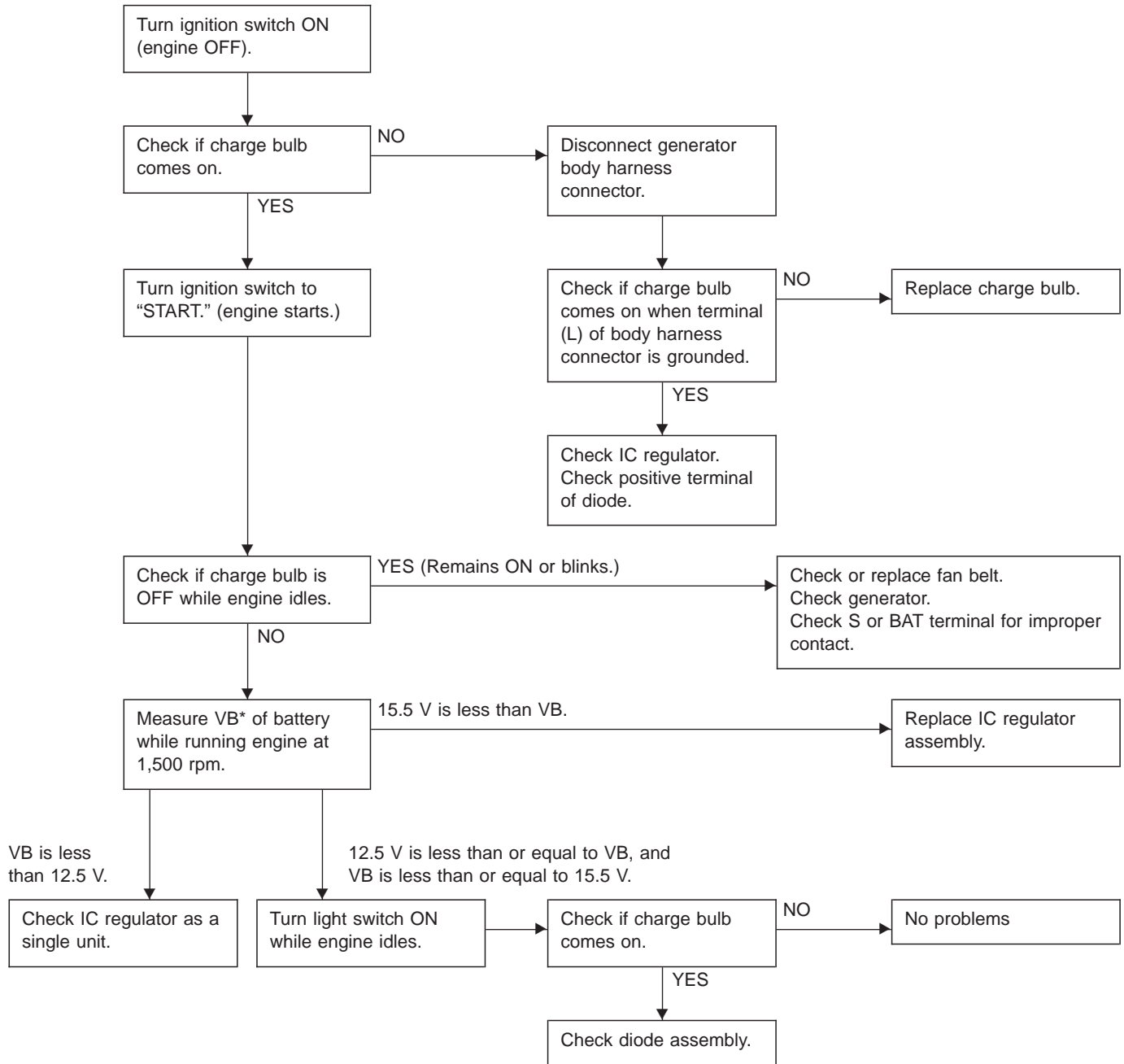

*: Terminal voltage

1. Body Electrical

A: SPECIFICATIONS

Battery	Reserve capacity	82 minutes (MT), 100 minutes (AT)
	Cold cranking ampere	430 amperes (MT), 490 amperes (AT)
Fuse		10 A, 15 A, 20 A
Combination meter	Speedometer	Electric pulse type
	Tachometer	Electric impulse type
	Water temperature gauge	Thermistor cross coil type
	Fuel gauge	Resistance cross coil type
	Charge indicator light	12 V — 1.4 W
	Brake fluid level warning/parking brake indicator light	12 V — 1.4 W
	AT oil temperature warning light (AWD only)	12 V — 1.4 W
	ABS warning light	12 V — 1.4 W
	CHECK ENGINE warning light (Malfunction indicator lamp)	12 V — 1.4 W
	Oil pressure warning light	12 V — 1.4 W
	AIRBAG system warning light	12 V — 1.4 W
	Low fuel warning light	12 V — 3 W
	FWD indicator light	12 V — 1.4 W
	TCS warning light	12 V — 1.4 W
	TCS indicator light	12 V — 1.4 W
	Turn signal indicator light	12 V — 1.4 W (2 pieces)
	Seat belt warning light	12 V — 1.4 W
	Door open warning light	12 V — 1.4 W (5 pieces)
	Headlight beam indicator light	12 V — 1.4 W
	Meter illumination light	12 V — 3 W (2 pieces) 12 V — 3.4 W (4 pieces)
Headlight		12 V — 60/55 W (Halogen)
Front clearance light		12 V — 5 W
Turn signal light	Front	12 V — 21 W
	Rear	12 V — 21 W
Tail/Stop light		12 V — 5/21 W
Back-up light		12 V — 21 W
High-mount stop light		12 V — 18 W (SEDAN), 12 V — 13 W (WAGON)
License plate light		12 V — 5 W
Room light		12 V — 8 W
Trunk room light (SEDAN)		12 V — 5 W
Luggage room light (WAGON)		12 V — 5 W
Spot light		12 V — 8 W (2 pieces)
Glove box light		12 V — 3.4 W
Ash tray illumination light		12 V — 1.7 W
Selector lever illumination light (AT model)		12 V — 1.7 W

Front wiper motor	Input	12 V — 54 W or less
Rear wiper motor	Input	12 V — 42 W or less
Front washer motor	Pump type	Centrifugal
	Input	12 V — 36 W or less
Rear washer motor	Pump type	Centrifugal
	Input	12 V — 36 W or less
Horn		12 V — 350 Hz
Cigarette lighter	Input	12 V — 120 W
Rear window defogger	Input	12 V — 160 W
	Indicator light	12 V — 50 mA

1. Precaution

- Before disassembling or reassembling parts, always disconnect battery ground cable. When repairing radio, control modules, etc. which are provided with memory functions, record memory contents before disconnecting battery ground cable. Otherwise, these contents are cancelled upon disconnection.
- Reassemble parts in reverse order of disassembly procedure unless otherwise indicated.
- Adjust parts to specifications contained in this manual if so designated.
- Connect connectors and hoses securely during reassembly.
- After reassembly, ensure functional parts operate smoothly.

CAUTION:

- Airbag system wiring harness is routed near the electrical parts and switch.
- All Airbag system wiring harness and connectors are colored yellow. Do not use electrical test equipment on these circuit.
- Be careful not to damage Airbag system wiring harness when servicing the ignition key cylinder.

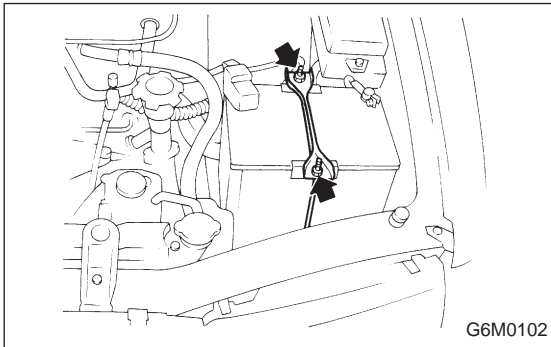

2. Battery

A: REMOVAL AND INSTALLATION

1. BATTERY

- 1) Disconnect the positive (+) terminal after disconnecting the negative (-) terminal of battery.
- 2) Remove flange nuts from battery rods and take off battery holder.
- 3) Remove battery.

Tightening torque:

$3.4 \pm 1.0 \text{ N}\cdot\text{m}$ ($0.35 \pm 0.1 \text{ kg}\cdot\text{m}$, $2.5 \pm 0.7 \text{ ft}\cdot\text{lb}$)

NOTE:

- Clean battery cable terminals and apply grease to retard the formation of corrosion.
- Connect the positive (+) terminal of battery and then the negative (-) terminal of the battery.

1. Precaution

- Before disassembling or reassembling parts, always disconnect battery ground cable. When repairing radio, control modules, etc. which are provided with memory functions, record memory contents before disconnecting battery ground cable. Otherwise, these contents are cancelled upon disconnection.
- Reassemble parts in reverse order of disassembly procedure unless otherwise indicated.
- Adjust parts to specifications contained in this manual if so designated.
- Connect connectors and hoses securely during reassembly.
- After reassembly, ensure functional parts operate smoothly.

CAUTION:

- Airbag system wiring harness is routed near the electrical parts and switch.
- All Airbag system wiring harness and connectors are colored yellow. Do not use electrical test equipment on these circuit.
- Be careful not to damage Airbag system wiring harness when servicing the ignition key cylinder.

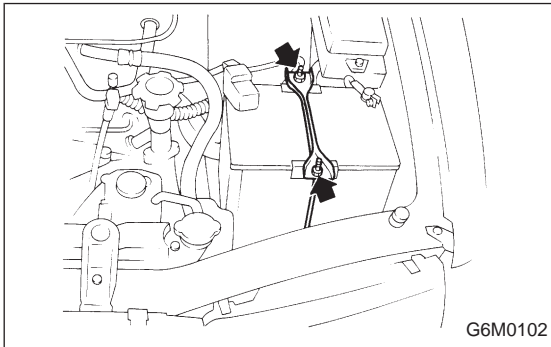

2. Battery

A: REMOVAL AND INSTALLATION

1. BATTERY

- 1) Disconnect the positive (+) terminal after disconnecting the negative (-) terminal of battery.
- 2) Remove flange nuts from battery rods and take off battery holder.
- 3) Remove battery.

Tightening torque:

$3.4 \pm 1.0 \text{ N}\cdot\text{m}$ ($0.35 \pm 0.1 \text{ kg}\cdot\text{m}$, $2.5 \pm 0.7 \text{ ft}\cdot\text{lb}$)

NOTE:

- Clean battery cable terminals and apply grease to retard the formation of corrosion.
- Connect the positive (+) terminal of battery and then the negative (-) terminal of the battery.

B: INSPECTION**1. BATTERY**

1) External parts

Check for the existence of dirt or cracks on the battery case, top cover, vent plugs, and terminal posts. If necessary, clean with water and wipe with a dry cloth.

Apply a thin coat of grease on the terminal posts to prevent corrosion.

2) Electrolyte level

Check the electrolyte level in each cell. If the level is below MIN LEVEL, bring the level to MAX LEVEL by pouring distilled water into the battery cell. Do not fill beyond MAX LEVEL.

WARNING:

- Electrolyte has toxicity; be careful handling the fluid.
- Avoid contact with skin, eyes or clothing. Especially at contact with eyes, flush with water for 15 minutes and get prompt medical attention.
- Batteries produce explosive gasses. Keep sparks, flame, cigarettes away.
- Ventilate when charging or using in enclosed space.
- For safety, in case an explosion does occur, wear eye protection or shield your eyes when working near any battery. Never lean over a battery.
- Do not let battery fluid contact eyes, skin, fabrics, or paint-work because battery fluid is corrosive acid.
- To lessen the risk of sparks, remove rings, metal watch-bands, and other metal jewelry. Never allow metal tools to contact the positive battery terminal and anything connected to it while you are at the same time in contact with any other metallic portion of the vehicle because a short circuit will be caused.

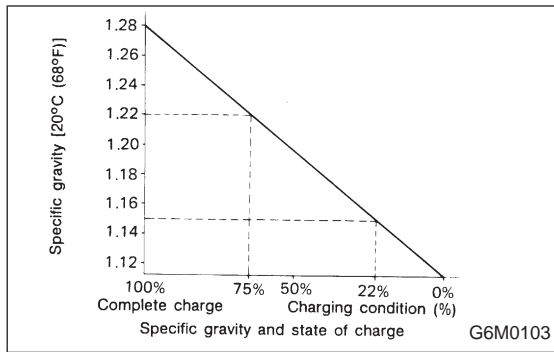

3) Specific gravity of electrolyte

Measure specific gravity of electrolyte using a hydrometer and a thermometer.

Specific gravity varies with temperature of electrolyte so that it must be corrected at 20°C (68°F) using the following equation:

$$S_{20} = S_t + 0.0007 \times (t - 20)$$

S_{20} : Specific gravity corrected at electrolyte temperature of 20°C (68°F)

S_t : Measured specific gravity

t : Measured temperature °C

Determine whether or not battery must be charged, according to corrected specific gravity.

Standard specific gravity: 1.220 — 1.290 [at 20°C (68°F)]

Measuring the specific gravity of the electrolyte in the battery will disclose the state of charge of the battery. The relation between the specific gravity and the state of charge is as shown in figure.

C: CHARGING

WARNING:

- Do not bring an open flame close to the battery at this time.

CAUTION:

- Prior to charging, corroded terminals should be cleaned with a brush and common baking soda solution.
- Be careful since battery electrolyte overflows while charging the battery.
- Observe instructions when handling battery charger.
- Before charging the battery on vehicle, disconnect battery ground terminal. Failure to follow this rule may damage generator's diodes or other electrical units.

1. NORMAL CHARGING

Charge the battery at current value specified by manufacturer or at approximately 1/10 of battery's ampere hour rating.

2. QUICK CHARGING

Quick charging is a method in which the battery is charged in a short period of time with a relatively large current by using a quick charger.

Since a large current flow raises electrolyte temperature, the battery is subject to damage if the large current is used for prolonged time. For this reason, the quick charging must be carried out within a current range that will not increase the electrolyte temperature above 40°C (104°F).

It should be also remembered that the quick charging is a temporary means to bring battery voltage up to a fair value and, as a rule, a battery should be charged slowly with a low current.

CAUTION:

- Observe the items in 1. NORMAL CHARGING 6-2 [W2C1].
- Never use more than 10 amperes when charging the battery because that will shorten battery life.

3. JUDGMENT OF BATTERY IN CHARGED CONDITION

- 1) Specific gravity of electrolyte is held at a specific value in a range from 1.250 to 1.290 for more than one hour.
- 2) Voltage per battery cell is held at a specific value in a range from 2.5 to 2.8 volts for more than one hour.

4. CHECK HYDROMETER FOR STATE OF CHARGE

Hydrometer indicator	State of charge	Required action
Green dot	Above 65%	Load test
Dark dot	Below 65%	Charge battery
Clear dot	Low electrolyte	Replace battery.* (If cranking complaint)

*: Check electrical system before replacement.

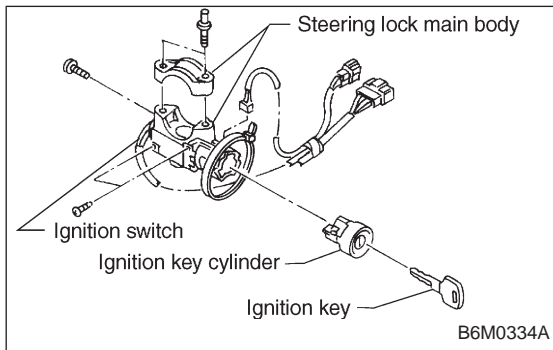
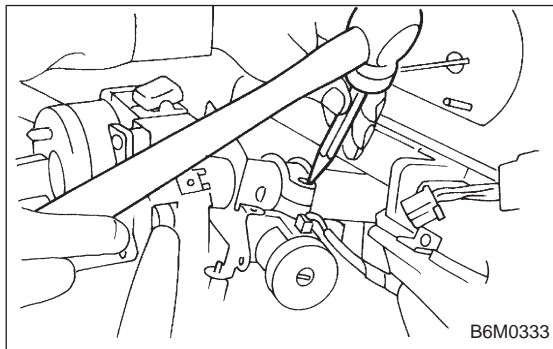
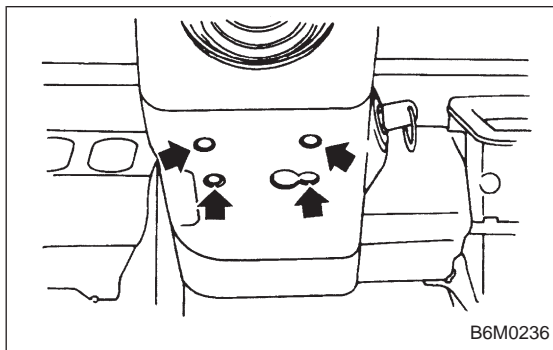

3. Ignition Switch

A: REMOVAL AND INSTALLATION

1. IGNITION SWITCH

- 1) Remove screws, separate upper column cover and lower column cover.
- 2) Remove instrument panel lower cover.

- 3) Disconnect ignition switch connector from body harness.
- 4) Using a drift and hammer, hit the torn bolt head to loosen and remove the ignition switch.

- 5) When installing, tighten the connecting bolt until its head twists off.

CAUTION:

- Observe the items in 1. NORMAL CHARGING 6-2 [W2C1].
- Never use more than 10 amperes when charging the battery because that will shorten battery life.

3. JUDGMENT OF BATTERY IN CHARGED CONDITION

- 1) Specific gravity of electrolyte is held at a specific value in a range from 1.250 to 1.290 for more than one hour.
- 2) Voltage per battery cell is held at a specific value in a range from 2.5 to 2.8 volts for more than one hour.

4. CHECK HYDROMETER FOR STATE OF CHARGE

Hydrometer indicator	State of charge	Required action
Green dot	Above 65%	Load test
Dark dot	Below 65%	Charge battery
Clear dot	Low electrolyte	Replace battery.* (If cranking complaint)

*: Check electrical system before replacement.

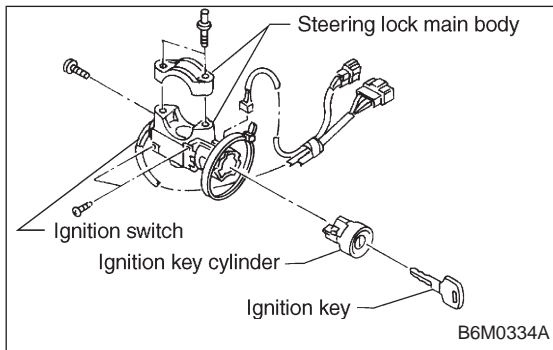
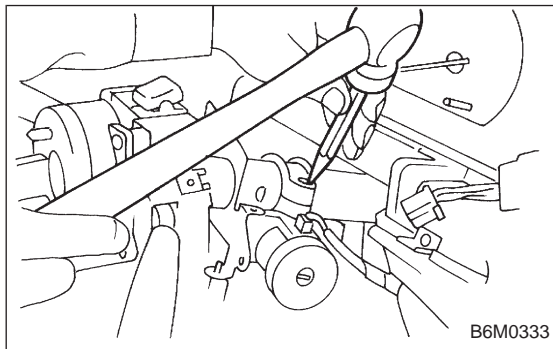
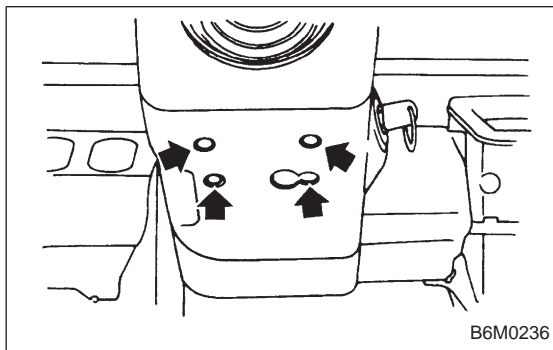

3. Ignition Switch

A: REMOVAL AND INSTALLATION

1. IGNITION SWITCH

- 1) Remove screws, separate upper column cover and lower column cover.
- 2) Remove instrument panel lower cover.

- 3) Disconnect ignition switch connector from body harness.
- 4) Using a drift and hammer, hit the torn bolt head to loosen and remove the ignition switch.

- 5) When installing, tighten the connecting bolt until its head twists off.

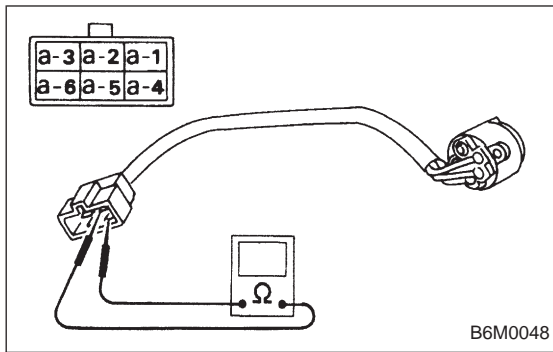

B: INSPECTION

1. IGNITION SWITCH (ON-CAR)

- 1) Remove instrument panel lower cover.
- 2) Remove lower column cover.
- 3) Unfasten holddown clip which secures harness, and disconnect connector of ignition switch from body harness.
- 4) Turn ignition key to each position and check continuity between terminals of ignition switch connector.

Position	Terminal	a-1	a-2	a-5	a-4
LOCK					
ACC		○	○		
ON		○	○	○	
START		○	○	○	○

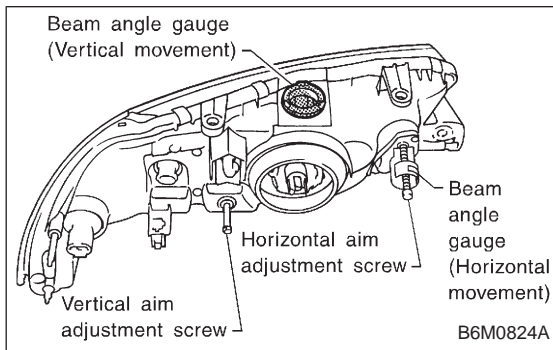

4. Headlight

A: ADJUSTMENT

1. HEADLIGHT AIMING

- 1) Adjust the headlight aiming by turning the adjusting screws.

CAUTION:

Before checking the headlight aiming, be sure of the following:

- Turn off the light before adjusting headlight aiming. If the light is necessary to check aiming, do not turn on for more than two minutes.
- The area around the headlight has not sustained any accident, damage or other type of deformation.
- Vehicle is parked on level ground.
- The inflation pressure of tires is correct.
- Vehicle's gas tank is fully charged.
- Bounce the vehicle several times to normalize the suspension.
- Make certain that someone is seated in the driver's seat.

NOTE:

Adjust vertical aim first, then horizontal aim.

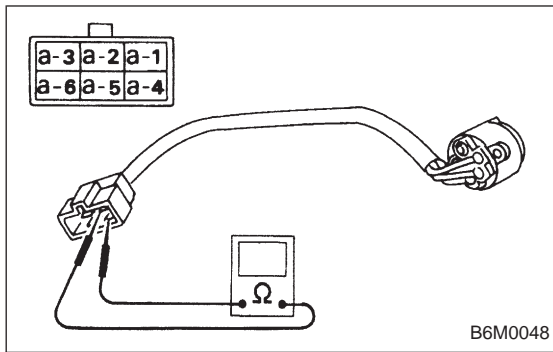

B: INSPECTION

1. IGNITION SWITCH (ON-CAR)

- 1) Remove instrument panel lower cover.
- 2) Remove lower column cover.
- 3) Unfasten holddown clip which secures harness, and disconnect connector of ignition switch from body harness.
- 4) Turn ignition key to each position and check continuity between terminals of ignition switch connector.

Position	Terminal	a-1	a-2	a-5	a-4
LOCK					
ACC		○	○		
ON		○	○	○	
START		○	○	○	○

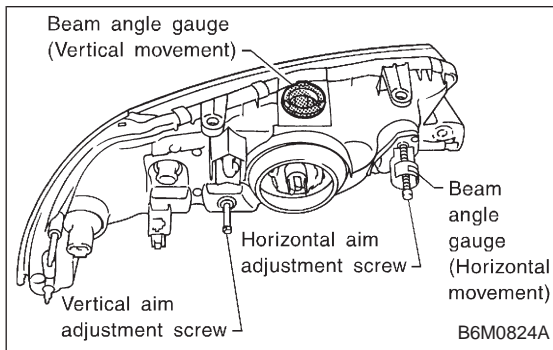

4. Headlight

A: ADJUSTMENT

1. HEADLIGHT AIMING

- 1) Adjust the headlight aiming by turning the adjusting screws.

CAUTION:

Before checking the headlight aiming, be sure of the following:

- Turn off the light before adjusting headlight aiming. If the light is necessary to check aiming, do not turn on for more than two minutes.
- The area around the headlight has not sustained any accident, damage or other type of deformation.
- Vehicle is parked on level ground.
- The inflation pressure of tires is correct.
- Vehicle's gas tank is fully charged.
- Bounce the vehicle several times to normalize the suspension.
- Make certain that someone is seated in the driver's seat.

NOTE:

Adjust vertical aim first, then horizontal aim.

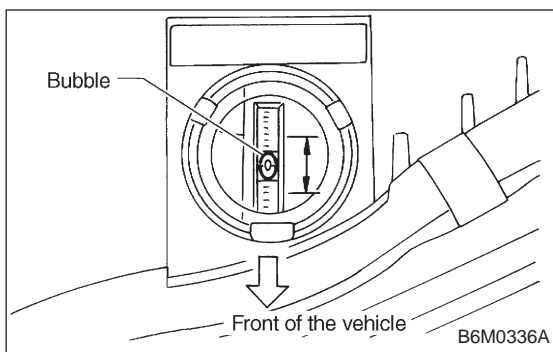

2) Look at the beam angle gauge (vertical movement). The bubble on the gauge should not deviate from the center of the gauge.

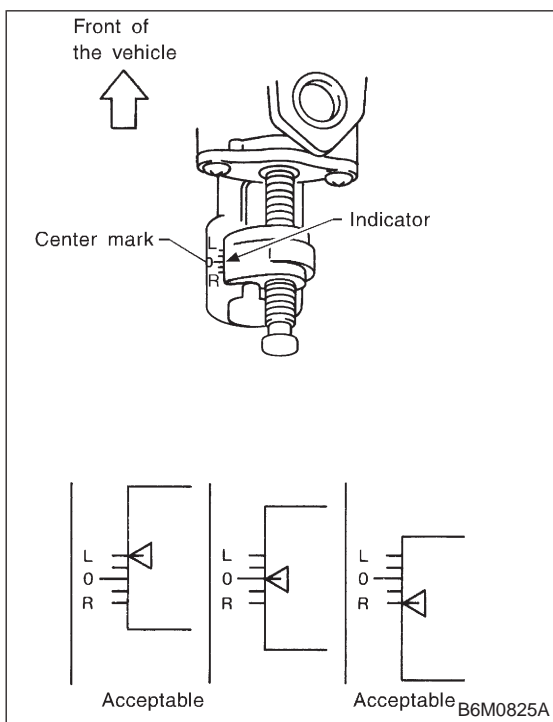

3) Look at the beam angle gauge (horizontal movement). The indicator should not deviate from the center of the gauge by more than two segments on either side of the gauge.

B: REMOVAL AND INSTALLATION

1. HEADLIGHT BULB

- 1) Disconnect the connector from inside of the engine compartment.
- 2) Remove rubber cap.
- 3) Remove the light bulb retaining spring to remove the bulb.
- 4) Replace the bulb with a new one and hook the spring.
- 5) Attach the rubber cap and connect the connector.

CAUTION:

- Since the tungsten halogen bulb operates at high temperature, dirt and oil on the bulb surface decreases the bulb's useful life. When replacing the bulb, hold the flange portion and do not touch the glass portion.

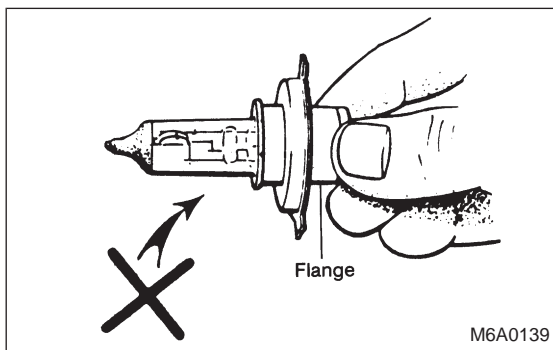

4. Headlight

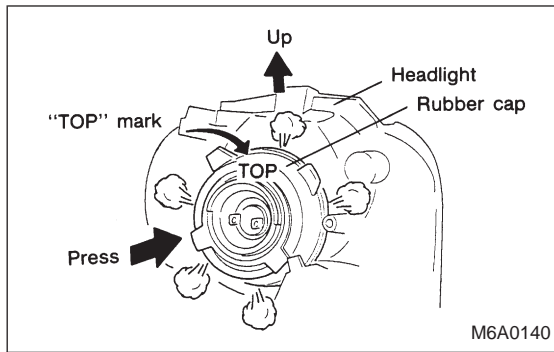

- Attach the rubber cap with letters TOP on the top so that the drain hole will be on the lower side.
- To keep water out, correctly engage the groove portion of the rubber cap.

2. HEADLIGHT

- 1) Remove front grille and disconnect connectors from headlight.

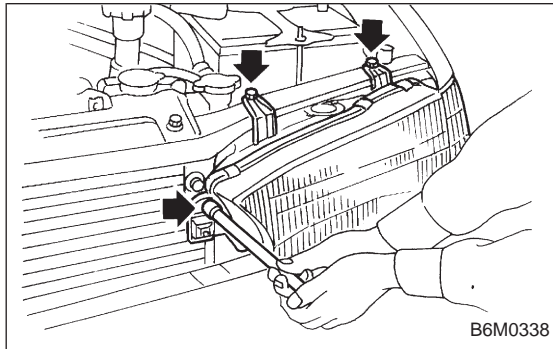

- 2) Remove bolts which secure headlight and remove headlight.

Tightening torque:

$6.4 \pm 0.5 \text{ N}\cdot\text{m}$ ($0.65 \pm 0.05 \text{ kg}\cdot\text{m}$, $4.7 \pm 0.4 \text{ ft}\cdot\text{lb}$)

NOTE:

When installing the headlight, securely fit clip into locating.

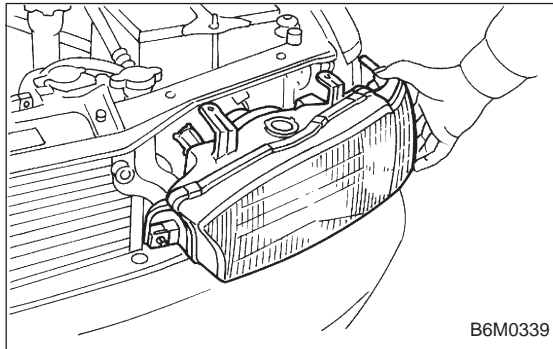

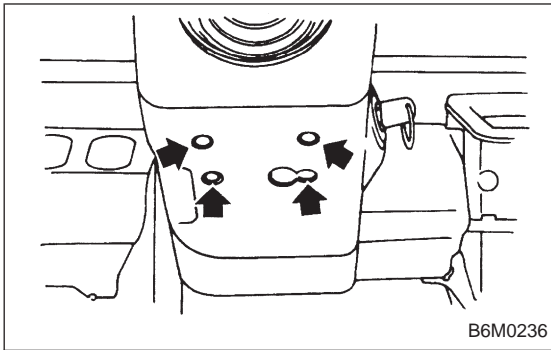

3. COMBINATION SWITCH (WITHOUT AIRBAG MODEL)

Refer to 5-5 [W7A0] as for removal of combination switch on airbag equipped model.

- 1) Remove steering wheel. <Ref. to 4-3 [W2A0].>
- 2) Remove screws which secure upper column cover to lower column cover.
- 3) Remove screws which secure knee protector and remove knee protector.

CAUTION:

When installing knee protector, ensure that harness is not caught by adjacent parts.

- 4) Disconnect connector from body harness and undo holddown band.

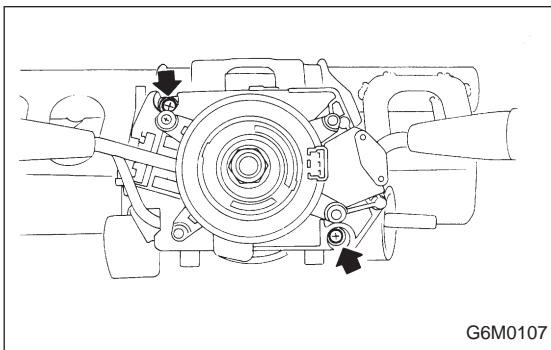

- 5) Remove screws which secure switch and remove switch.

CAUTION:

During installation (with key interlock)

- When routing combination switch harness around steering system, do not place it over key interlock release knob.
- After installing lower column cover, ensure that key interlock release knob is accessible.

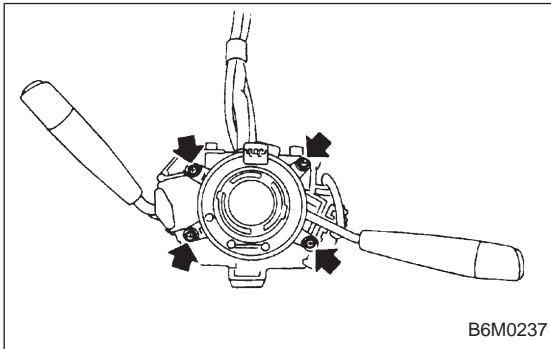

C: DISASSEMBLY AND ASSEMBLY

1. COMBINATION SWITCH

- 1) Remove screws which secure slip ring to combination switch, and remove slip ring.

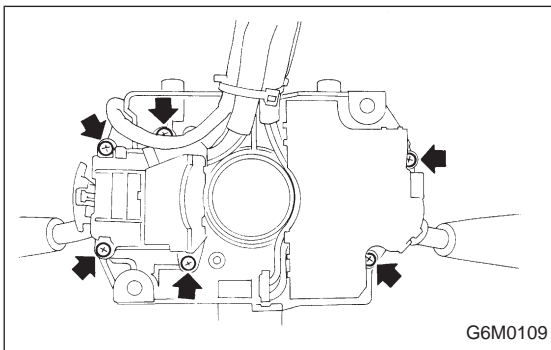

- 2) Remove screws which secure lighting switch, wiper and washer switch. Remove both switches.
Assembly is in the reverse order of disassembly.

D: INSPECTION

1. COMBINATION SWITCH (ON-CAR)

- 1) Remove instrument panel lower cover.
- 2) Remove lower column cover.

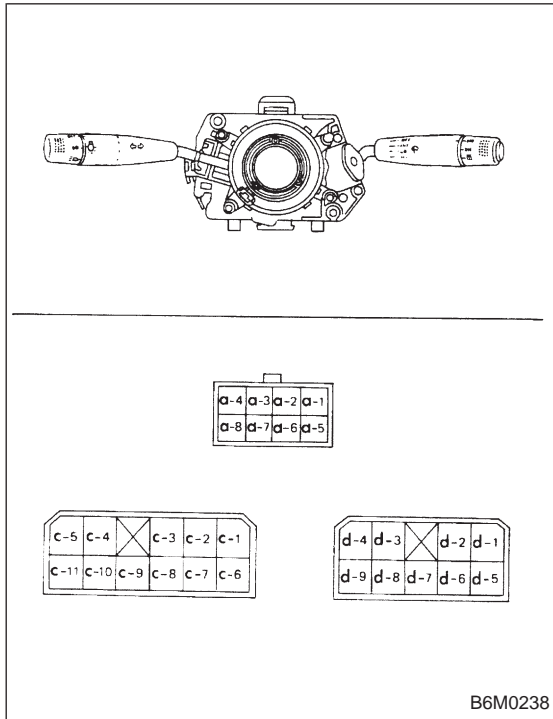

- 3) Unfasten holddown clip which secures harness, and disconnect connectors from body harness.

- 4) Move combination switch to respective positions and check continuity between terminals as indicated in the following tables:

Lighting switch

Terminal	c-1	c-2	c-3
Switch position			
OFF			
Tail	○	○	
↕	○	○	
Head	○	○	○

Parking switch

Terminal	c-10	c-11	c-9
Switch position			
OFF	○	○	
↕	X		X
ON		○	○

Dimmer and passing switch

Terminal	a-3	a-2	a-1	a-4
Switch position				
Flash	○		○	○
↕	○	○	○	
Low beam	○	○		
↕	○	○	○	
HI-beam	○		○	

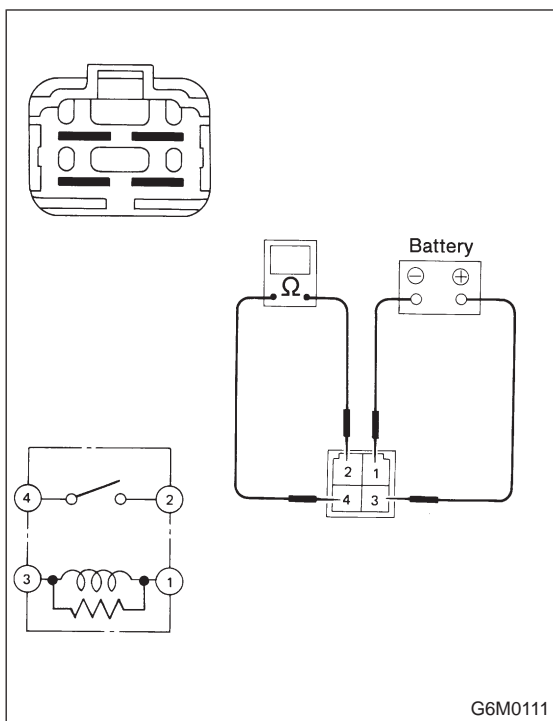

2. HEADLIGHT RELAY

Check continuity between terminals as indicated in table below, when connecting the battery to terminal No. 1 and No. 3.

When current flows.	Between terminals No. 2 and No. 4	Continuity exists.
When current does not flow.	Between terminals No. 2 and No. 4	Continuity does not exist.
	Between terminals No. 1 and No. 3	Continuity exists.

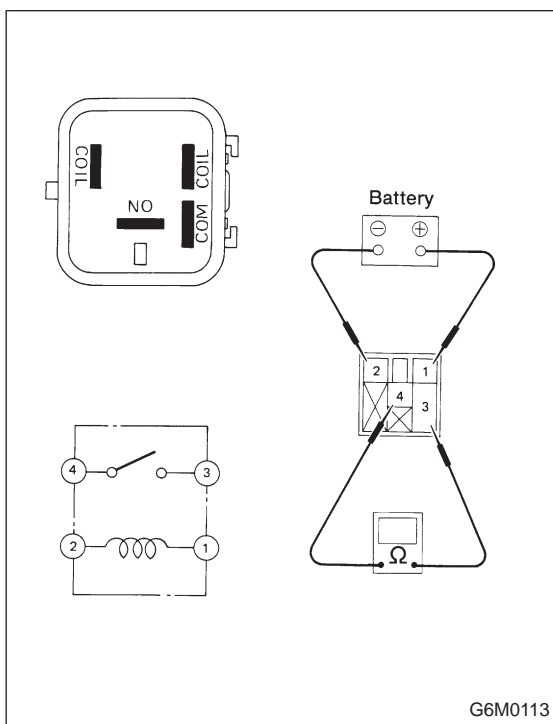

3. DAYTIME RUNNING LIGHT RELAY

Check continuity between terminals (indicated in table below) when terminal No. 1 is connected to battery and terminal No. 2 is grounded.

When current flows.	Between terminals No. 3 and No. 4	Continuity exists.
When current does not flow.	Between terminals No. 3 and No. 4	Continuity does not exist.
	Between terminals No. 1 and No. 2	Continuity exists.

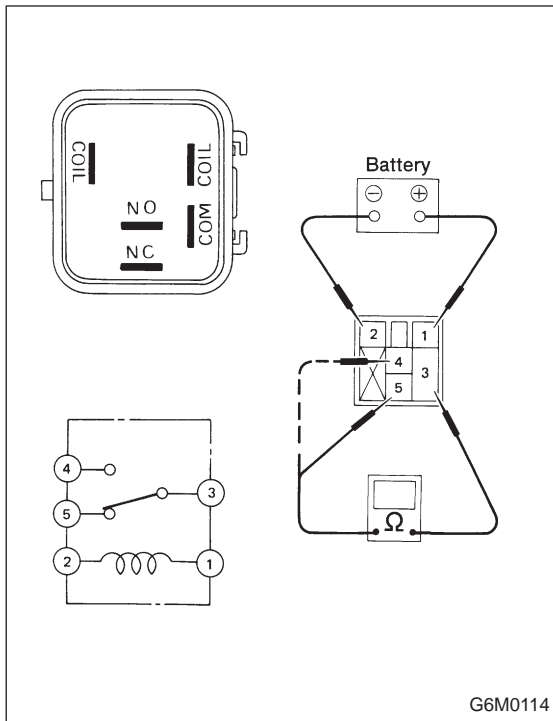

Check continuity between terminals (indicated in table below) when terminal No. 1 is connected to battery and terminal No. 2 is grounded.

When current flows.	Between terminals No. 3 and No. 5	Continuity does not exist.
	Between terminals No. 3 and No. 4	Continuity exists.
When current does not flow.	Between terminals No. 3 and No. 5	Continuity exists.
	Between terminals No. 3 and No. 4	Continuity does not exist.
	Between terminals No. 1 and No. 2	Continuity exists.

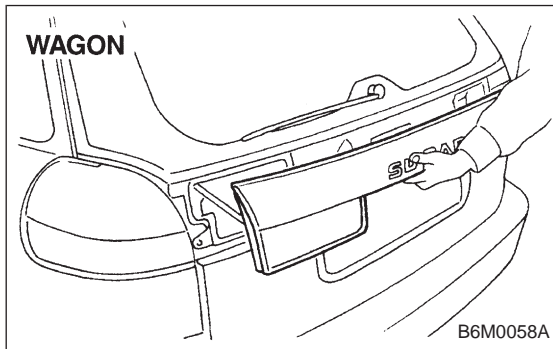
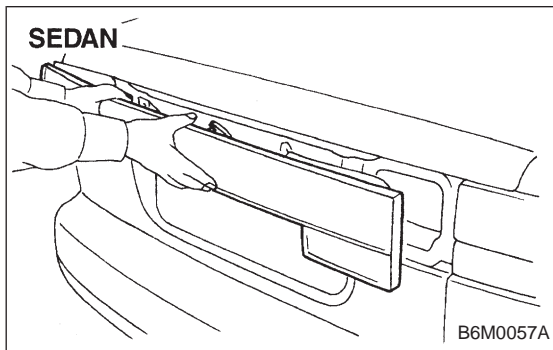
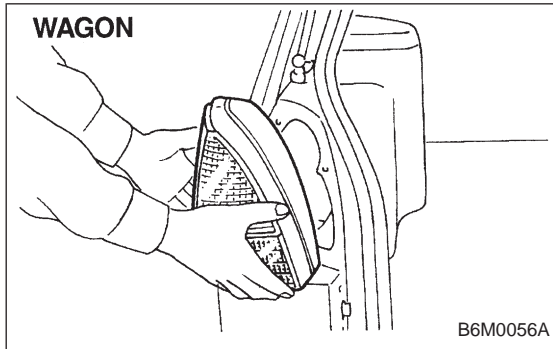
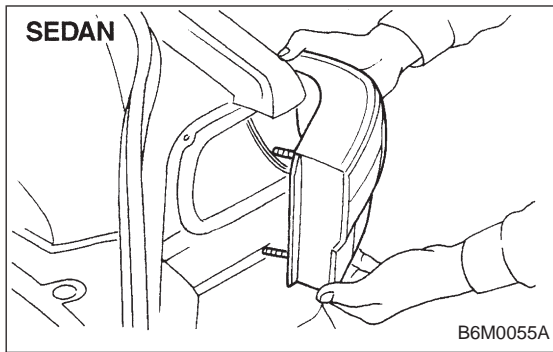

5. Stop and Tail Light

A: REMOVAL AND INSTALLATION

1. REAR COMBINATION LIGHT

- 1) Remove rear trim.
- 2) Disconnect connector from rear combination light.
- 3) Remove nuts which secure rear combination light.

Tightening torque:

$2.5 \pm 0.5 \text{ N} \cdot \text{m}$ ($0.25 \pm 0.05 \text{ kg} \cdot \text{m}$, $1.8 \pm 0.4 \text{ ft} \cdot \text{lb}$)

- 4) Attach adhesive cloth tape to body area around rear combination light.
- 5) Using a standard screwdriver, carefully pry rear combination light off and away from the vehicle.

CAUTION:

- Do not pry rear combination light forcefully as this may scratch vehicle body.
- Remove all traces of adhesive tape from body before installation.
- Attach butyl rubber tape to back of rear combination light before installing rear combination light on body for sealing purposes.

2. REAR FINISHER

- 1) Remove trunk lid trim (SEDAN) or rear gate trim (WAGON).
- 2) Disconnect connectors from rear finisher.
- 3) Remove rear wiper motor (WAGON).
- 4) Remove nuts which secure rear finisher.

Tightening torque:

$2.5 \pm 0.5 \text{ N} \cdot \text{m}$ ($0.25 \pm 0.05 \text{ kg} \cdot \text{m}$, $1.8 \pm 0.4 \text{ ft} \cdot \text{lb}$)

- 5) Attach adhesive cloth tape to body area around rear finisher.
- 6) Using a standard screwdriver, carefully pry rear finisher off and away from the vehicle.

CAUTION:

- Do not pry rear finisher forcefully as this may scratch vehicle body.

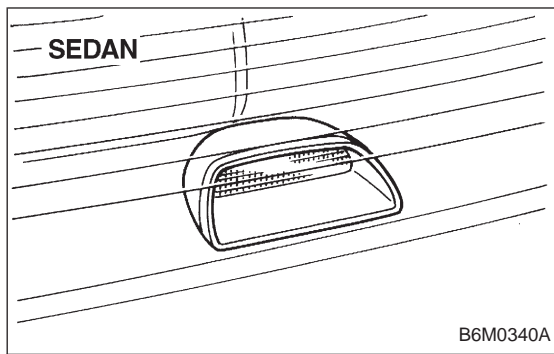

3. HIGH-MOUNT STOP LIGHT (SEDAN)

- 1) Disconnect connector of high-mount stop light from body harness.
- 2) Remove screws which secure high-mount stop light to rear shelf panel.
- 3) Remove high-mount stop light.

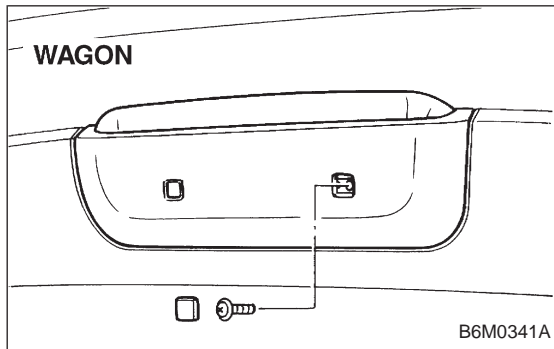

4. HIGH-MOUNT STOP LIGHT (WAGON)

- 1) Remove high-mount stop light cover from rear gate trim panel.
- 2) Remove screws which secure high-mount stop light.
- 3) Remove high-mount stop light while disconnecting connector from body harness.

5. STOP LIGHT SWITCH

Refer to 4-5 [C101 (MT) or C201 (AT)] as for removal and installation of stop light switch.

NOTE:

When installing the stop light switch, adjust the pedal height by adjusting the stop light switch position.

6. COMBINATION SWITCH

Refer to 6-2 [W4B3] as for removal and installation of combination switch.

B: DISASSEMBLY AND ASSEMBLY

1. COMBINATION SWITCH

Refer to 6-2 [W4C1] as for disassembly and assembly of combination switch.

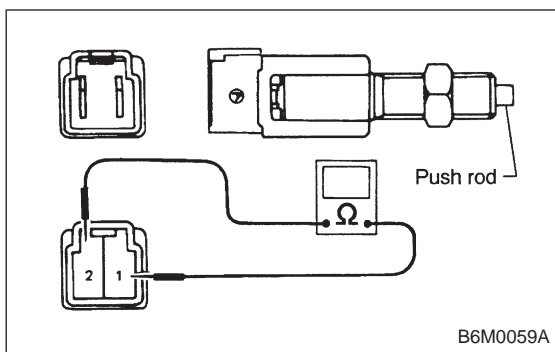

C: INSPECTION

1. STOP LIGHT SWITCH (ON-CAR)

Without cruise control model

- 1) Disconnect connector of stop light switch from body harness.
- 2) Check continuity between terminals when push rod is pushed in 4.0 to 4.5 mm (0.157 to 0.177 in) from end of outer case.

Terminal	1	2
Switch position		
When push rod is pushed in.		
When push rod is released.	○	○

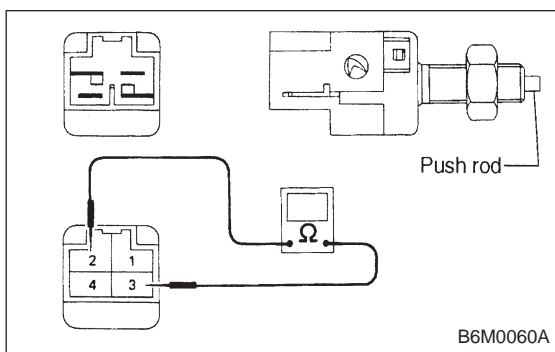

With cruise control model

- 1) Disconnect connector of stop light switch from body harness.
- 2) Check continuity between terminals when push rod is pushed in 1.5 to 3.0 mm (0.059 to 0.118 in) from end of outer case.

Terminal	1	2	3	4
Switch position				
When push rod is pushed in.	○			○
When push rod is released.		○	○	

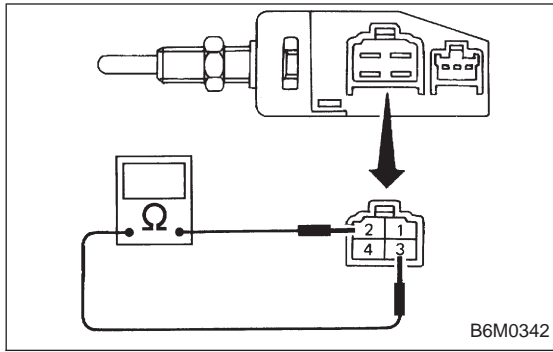

With TCS model

- 1) Disconnect connector of stop light switch from body harness.
- 2) Check continuity between terminals when push rod is pushed in 1.2 to 3.2 mm (0.047 to 0.126 in) from end of outer case.

Terminal	1	2	3	4
Switch position				
When push rod is pushed in.	○	—	—	○
When push rod is released.		○	—	○

2. COMBINATION SWITCH (ON-CAR)

Refer to 6-2 [W4D1] as for inspection of combination switch.

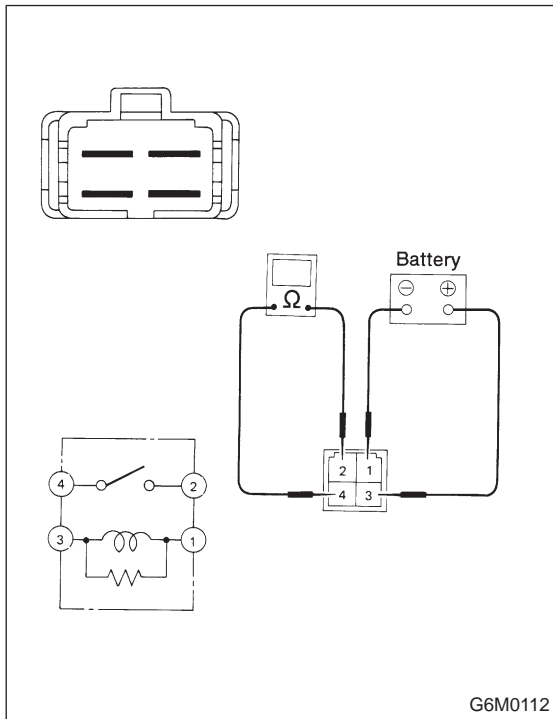

3. TAIL AND ILLUMINATION RELAY

Check continuity between terminals as indicated in table below, when connecting battery to terminal No. 1 and No. 3

When current flows.	Between terminals No. 2 and No. 4	Continuity exists.
When current does not flow.	Between terminals No. 2 and No. 4	Continuity does not exist.
	Between terminals No. 1 and No. 3	Continuity exists.

6. Turn Signal and Hazard Warning Light

A: REMOVAL AND INSTALLATION

1. FRONT TURN SIGNAL LIGHT

Refer to 6-2 [W4B2] as for removal and installation of front turn signal light.

NOTE:

The front turn signal light is united with headlight assembly.

2. REAR COMBINATION LIGHT

Refer to 6-2 [W5A1] as for removal and installation of rear combination light.

3. COMBINATION SWITCH

Refer to 6-2 [W4B3] as for removal and installation of combination switch.

4. HAZARD SWITCH

- 1) Remove center panel from instrument panel. <Ref. to 5-4 [W1A0].>
- 2) Disconnect connector of hazard switch from body harness.
- 3) Remove hazard switch from center panel.

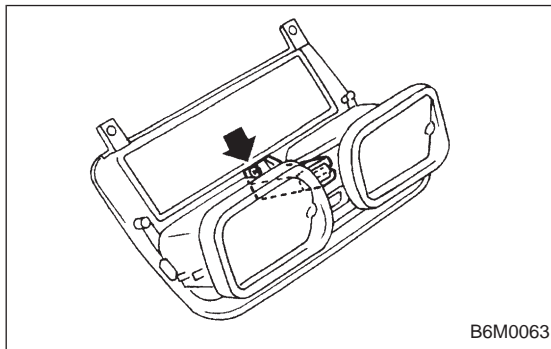

5. TURN SIGNAL AND HAZARD UNIT

- 1) Remove instrument panel lower cover.
- 2) Remove engine hood opener lever bracket.
- 3) Disconnect connector of turn signal and hazard unit.
- 4) Remove screw, and then remove turn signal and hazard unit from bracket.

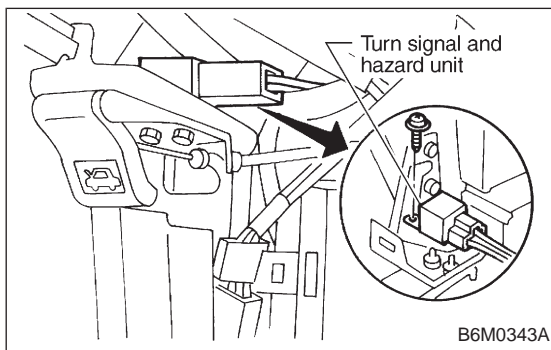

B: DISASSEMBLY AND ASSEMBLY

1. COMBINATION SWITCH

Refer to 6-2 [W4C1] as for disassembly and assembly of combination switch.

C: INSPECTION

1. COMBINATION SWITCH (ON-CAR)

- 1) Remove instrument panel lower cover.
- 2) Remove lower column cover.

- 3) Unfasten holddown clip which secures harness, and disconnect connectors from body harness.
- 4) Move combination switch to respective positions and check continuity between terminals as indicated in table below:

Turn signal switch

Switch position	Terminal	a-5	a-7	a-6
Turn	L·L'	○	○	
	↓	x		x
	N			
	↑	x		x
	R·R'		○	○

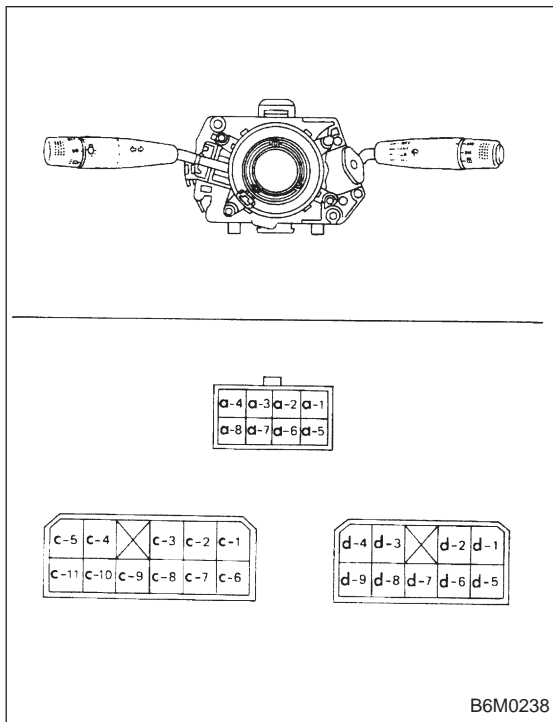

B6M0238

2. HAZARD SWITCH

Move hazard switch to each position and check continuity between terminals as indicated in table below:

	7	3	9	10	5	6	1	2
ON	○		○	○	○	○	○	○
OFF	○	○					○	○

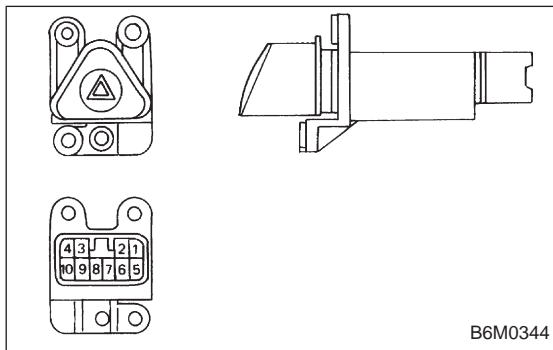

B6M0344

7. Back-up Light

A: REMOVAL AND INSTALLATION

1. BACK-UP LIGHT

Refer to 6-2 [W5A2] as for removal and installation of rear finisher.

2. BACK-UP LIGHT SWITCH (MT MODEL)

Refer to 3-1 [W2B1 (AWD) or W3A0 (FWD)] as for removal and installation of back-up light switch.

3. INHIBITOR SWITCH (AT MODEL)

Refer to 3-2 [W4A4] as for removal and installation of inhibitor switch (R position switch).

B: INSPECTION

1. INHIBITOR SWITCH (AT MODEL)

Refer to 3-2 [W2B2] as for inspection of inhibitor switch.

8. Room Light and Door Switch

A: REMOVAL AND INSTALLATION

1. ROOM LIGHT

- 1) Pry room light lens off using a screwdriver.
- 2) Remove screws which secure room light body.
- 3) Remove room light body while disconnecting connector.

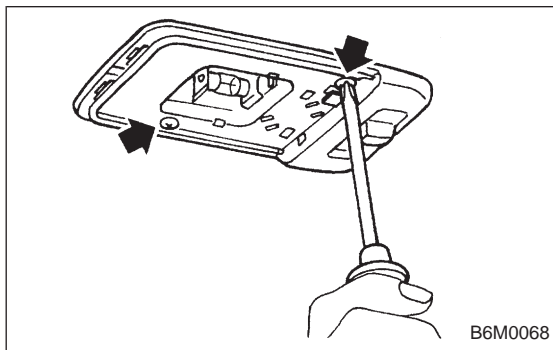

2. TRUNK ROOM LIGHT (SEDAN)

- 1) Turn trunk room light body by hand and remove it from rear shelf panel.
- 2) Disconnect connector of trunk room light.

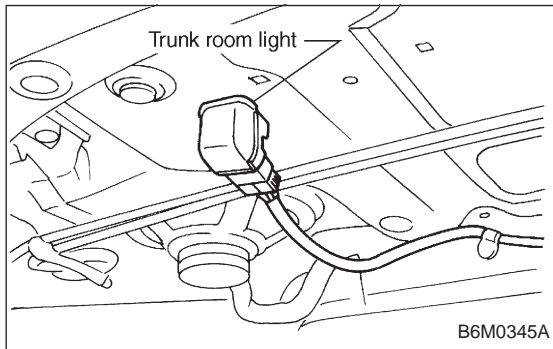

3. LUGGAGE ROOM LIGHT (WAGON)

- 1) Pry luggage room light lens off using a screwdriver.
- 2) Remove screws which secure luggage room light body.
- 3) Remove luggage room light body while disconnecting connector.

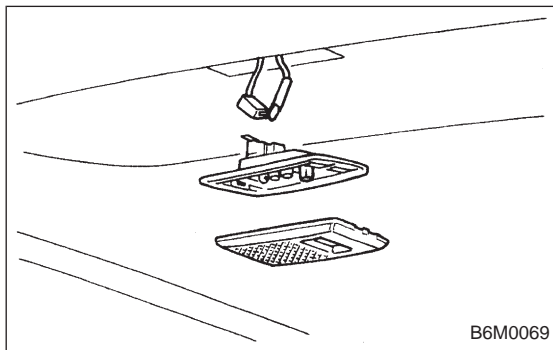

7. Back-up Light

A: REMOVAL AND INSTALLATION

1. BACK-UP LIGHT

Refer to 6-2 [W5A2] as for removal and installation of rear finisher.

2. BACK-UP LIGHT SWITCH (MT MODEL)

Refer to 3-1 [W2B1 (AWD) or W3A0 (FWD)] as for removal and installation of back-up light switch.

3. INHIBITOR SWITCH (AT MODEL)

Refer to 3-2 [W4A4] as for removal and installation of inhibitor switch (R position switch).

B: INSPECTION

1. INHIBITOR SWITCH (AT MODEL)

Refer to 3-2 [W2B2] as for inspection of inhibitor switch.

8. Room Light and Door Switch

A: REMOVAL AND INSTALLATION

1. ROOM LIGHT

- 1) Pry room light lens off using a screwdriver.
- 2) Remove screws which secure room light body.
- 3) Remove room light body while disconnecting connector.

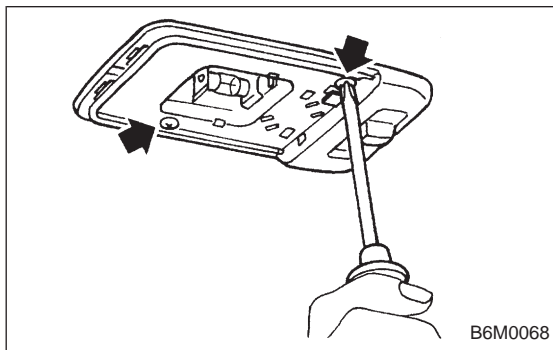

2. TRUNK ROOM LIGHT (SEDAN)

- 1) Turn trunk room light body by hand and remove it from rear shelf panel.
- 2) Disconnect connector of trunk room light.

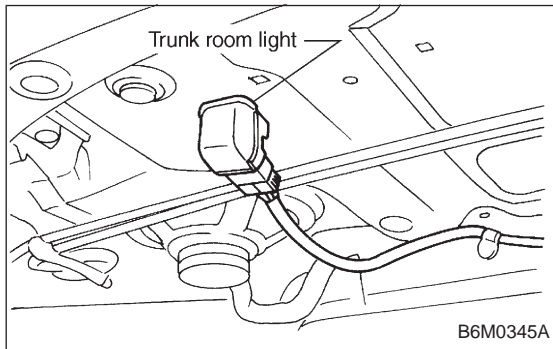

3. LUGGAGE ROOM LIGHT (WAGON)

- 1) Pry luggage room light lens off using a screwdriver.
- 2) Remove screws which secure luggage room light body.
- 3) Remove luggage room light body while disconnecting connector.

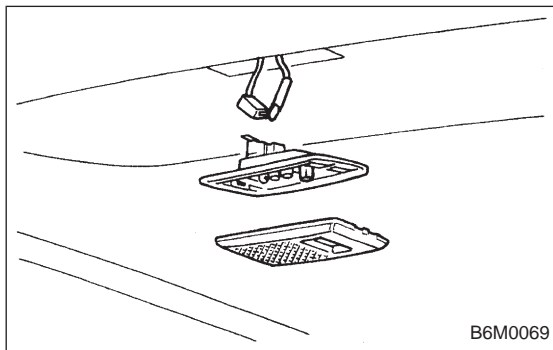

8. Room Light and Door Switch

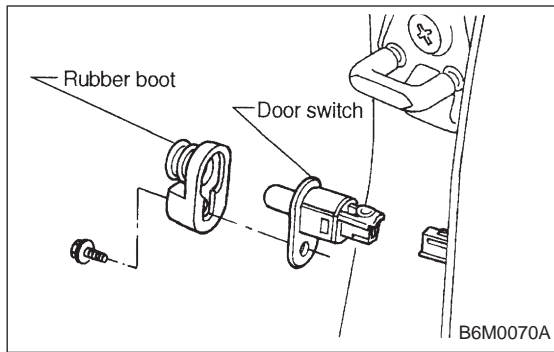

4. DOOR SWITCH

- 1) Remove rubber boot of door switch.
- 2) Remove screw which secures door switch to body.
- 3) Remove door switch while disconnecting connector.

5. TRUNK ROOM LIGHT SWITCH (SEDAN)

Refer to 5-1 [W2A3] as for removal and installation of trunk room light switch which is installed in trunk lid lock.

6. LUGGAGE ROOM LIGHT SWITCH (WAGON)

Refer to 5-2 [W3A2] as for removal and installation of luggage room light switch which is installed in rear gate lock.

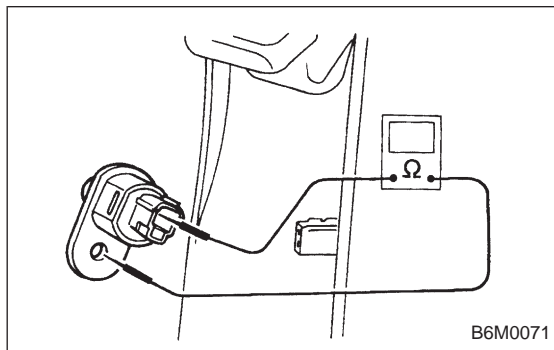

B: INSPECTION

1. DOOR SWITCH

Move switch and check continuity between terminal of door switch and switch body.

Switch position	Terminal	Switch body
Open (ON)	○	○
Push in (OFF)		

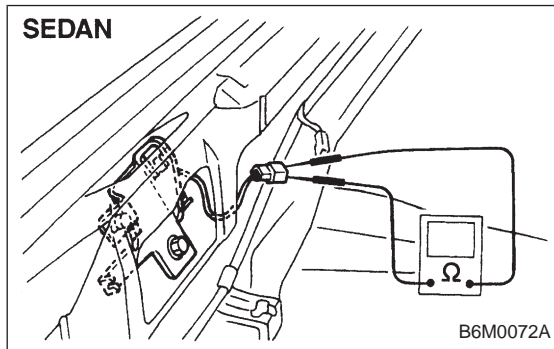

2. TRUNK ROOM LIGHT SWITCH (SEDAN)

Move switch and check continuity between terminals of trunk room light switch.

Terminal	1	2
Switch position		
Open (ON)	○	○
Push in (OFF)		

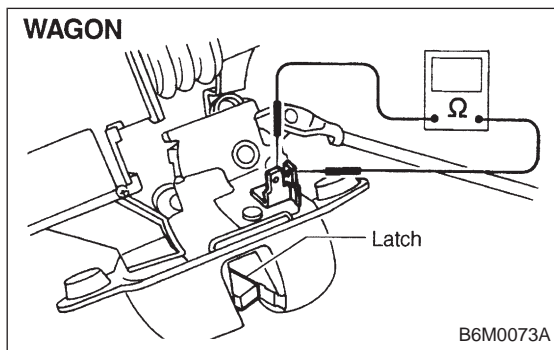

3. LUGGAGE ROOM LIGHT SWITCH (WAGON)

Move switch and check continuity between terminals of luggage room light switch.

Terminal	1	2
Switch position		
Open (ON)	○	○
Push in (OFF)		

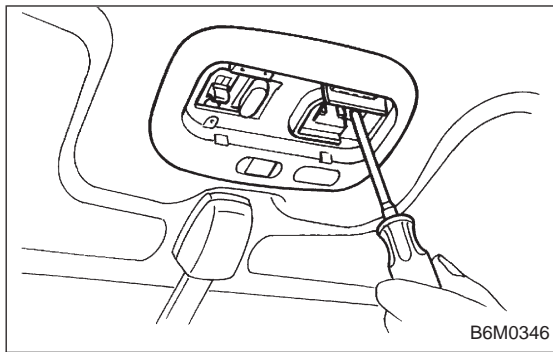

9. Spot Light

A: REMOVAL AND INSTALLATION

1. SPOT LIGHT AND SWITCH

- 1) Pry spot light lens off using a screwdriver.
- 2) Remove screws which secure spot light body.
- 3) Remove spot light body while disconnecting connector(s).

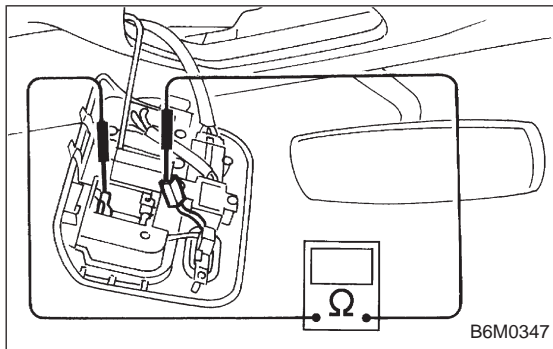

B: INSPECTION

1. SPOT LIGHT SWITCH

Move switch and check continuity between terminal of spot light switch connector and steel plate as shown.

Switch position	Connector terminal	Plate
Open (OFF)		
Push in (ON)		

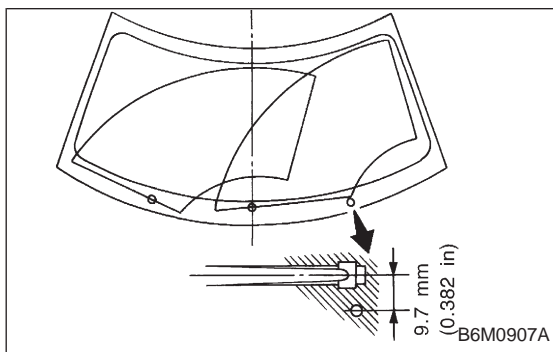

10. Front Wiper and Washer

A: ON-CAR SERVICES

1. ADJUSTMENT

- 1) Turn the wiper switch to OFF position.
- 2) Adjust blades in original position as shown in figure by changing wiper arm installation.

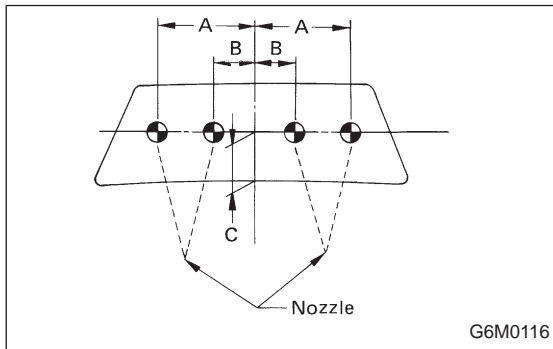

- 3) Stop the vehicle.
- 4) Adjust washer ejecting point on windshield glass as shown in figure.

Ejecting point:

- A: 375 mm (14.76 in)
- B: 150 mm (5.91 in)
- C: 380 mm (14.96 in)

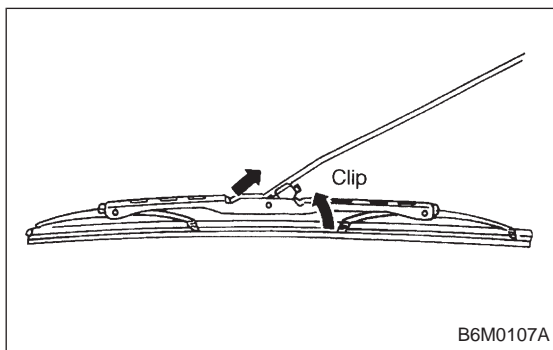

B: REMOVAL AND INSTALLATION

1. BLADE

Pull out blade following the arrow direction from arm while pushing up locking clip.

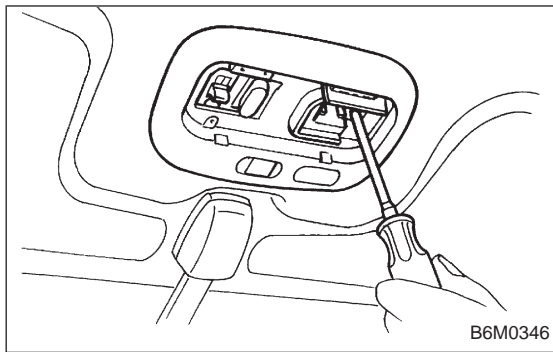

9. Spot Light

A: REMOVAL AND INSTALLATION

1. SPOT LIGHT AND SWITCH

- 1) Pry spot light lens off using a screwdriver.
- 2) Remove screws which secure spot light body.
- 3) Remove spot light body while disconnecting connector(s).

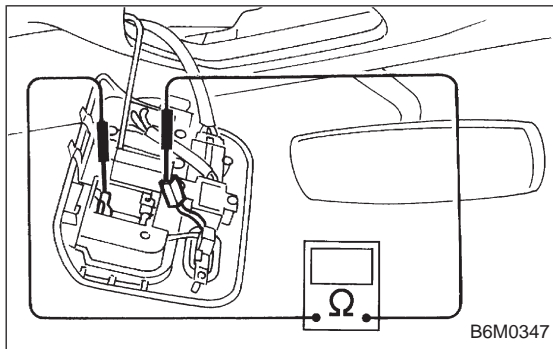

B: INSPECTION

1. SPOT LIGHT SWITCH

Move switch and check continuity between terminal of spot light switch connector and steel plate as shown.

Switch position	Connector terminal	Plate
Open (OFF)		
Push in (ON)		

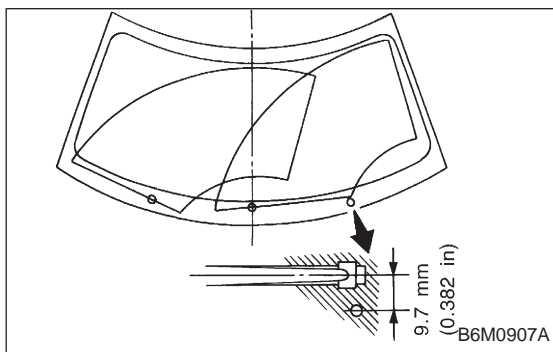

10. Front Wiper and Washer

A: ON-CAR SERVICES

1. ADJUSTMENT

- 1) Turn the wiper switch to OFF position.
- 2) Adjust blades in original position as shown in figure by changing wiper arm installation.

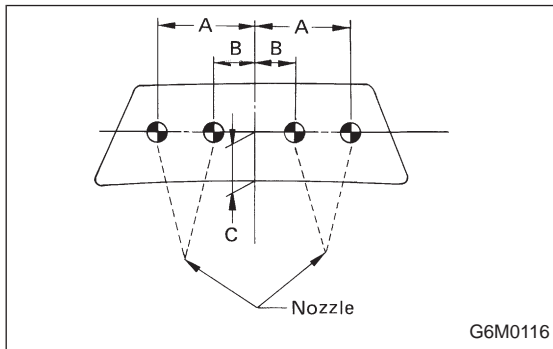

- 3) Stop the vehicle.
- 4) Adjust washer ejecting point on windshield glass as shown in figure.

Ejecting point:

- A: 375 mm (14.76 in)
- B: 150 mm (5.91 in)
- C: 380 mm (14.96 in)

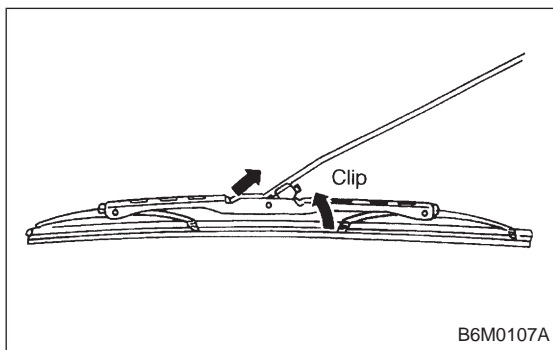

B: REMOVAL AND INSTALLATION

1. BLADE

Pull out blade following the arrow direction from arm while pushing up locking clip.

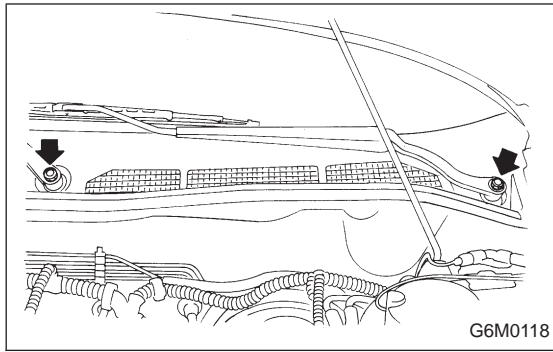

2. WIPER ARM

- 1) Open engine hood.
- 2) Remove cap of wiper arm installation nut.
- 3) Remove the nut which secures wiper arm.
- 4) Remove wiper arm.
- 5) Installation is in the reverse order of removal.

NOTE:

Remove metal sludge from the wiper arm fixture before installing it.

Tightening torque:

$20 \pm 3 \text{ N}\cdot\text{m}$ ($2.0 \pm 0.3 \text{ kg}\cdot\text{m}$, $14.5 \pm 2.2 \text{ ft}\cdot\text{lb}$)

3. WIPER MOTOR AND LINK

- 1) Detach weatherstrip and cowl panel. <Ref. to 5-1 [W10A0].>

NOTE:

Apply silicone oil or soap water to both sides of cowl net to facilitate removal.

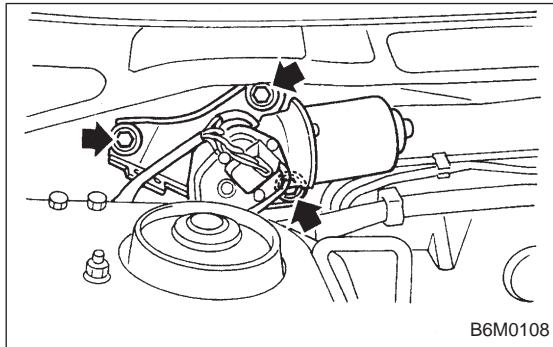

- 2) Disconnect connector of wiper motor.
- 3) Remove motor attaching bolts.

Tightening torque:

$5.9 \pm 1.5 \text{ N}\cdot\text{m}$ ($0.6 \pm 0.15 \text{ kg}\cdot\text{m}$, $4.3 \pm 1.1 \text{ ft}\cdot\text{lb}$)

- 4) Remove wiper link from back side of wiper motor using a screwdriver inserted into service hole in front panel.

CAUTION:

Do not pry wiper link off forcefully as this may scratch vehicle body.

- 5) Remove wiper motor.
- 6) Separate the driver's side wiper link from back side of the passenger's side wiper sleeve unit.

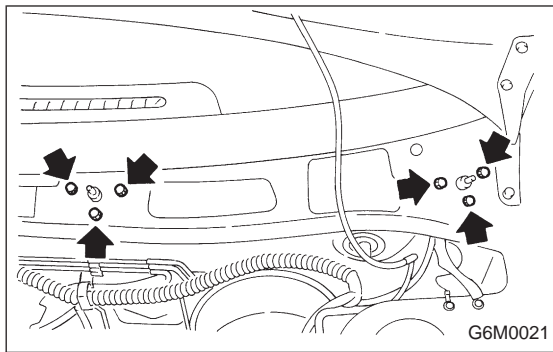

7) Remove nuts which secure sleeve unit.

Tightening torque:

$5.9 \pm 1.5 \text{ N}\cdot\text{m}$ ($0.6 \pm 0.15 \text{ kg}\cdot\text{m}$, $4.3 \pm 1.1 \text{ ft}\cdot\text{lb}$)

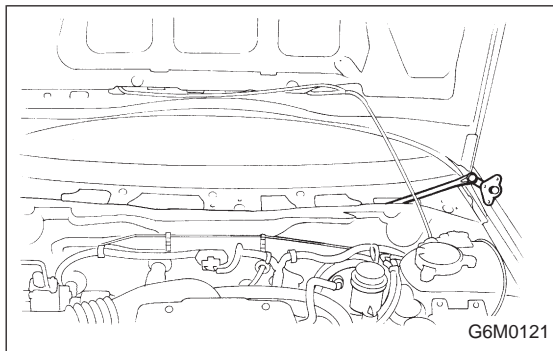

8) Remove wiper link from service hole in front panel.

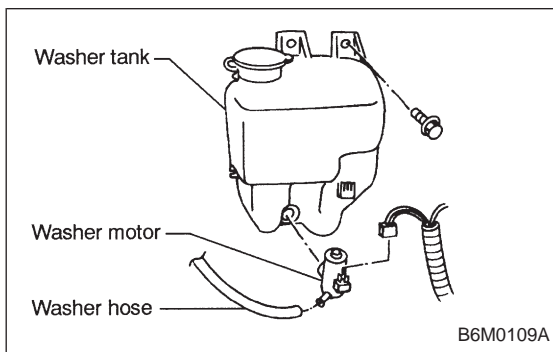

4. WASHER TANK AND WASHER MOTOR

- 1) Remove washer tank attaching bolts.
- 2) Disconnect connectors of washer motors.
- 3) Disconnect washer hoses from each washer motor.
- 4) Remove washer tank and washer motor as an unit.
- 5) Separate washer motor from washer tank.

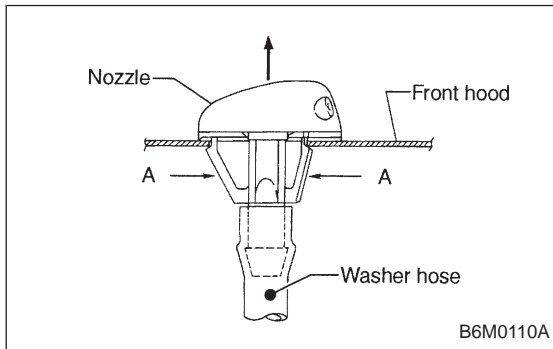

5. NOZZLE

- 1) Disconnect washer hose from nozzle.
- 2) Push nozzle clip in direction A as shown in figure.
- 3) Remove nozzle from engine hood.

CAUTION:

Do not pry nozzle off forcefully as this may scratch vehicle body.

6. COMBINATION SWITCH

Refer to 6-2 [W4B3] as for removal and installation of combination switch.

C: DISASSEMBLY AND ASSEMBLY

1. COMBINATION SWITCH AND INTERMITTENT UNIT

Refer to 6-2 [W4C1] as for disassembly and assembly of combination switch.

D: INSPECTION

1. COMBINATION SWITCH (ON-CAR)

- 1) Remove instrument panel lower cover.
- 2) Remove lower column cover.

- 3) Unfasten holddown clip which secures harness, and disconnect connectors from body harness.
- 4) Set wiper switch to each position and check continuity between terminals as indicated in table below:

Wiper switch

Terminal		d-9	d-8	d-6	d-7	INT1	INT2
Switch position							
OFF	OFF	○—○					
	↕	x—x					
	MIST		○—○				
INT	OFF	○—○				○—○	
	↕	x—x					
	MIST		○—○			○—○	
	↕	x—x					
LO	OFF		○—○				
	MIST		○—○				
HI	OFF			○—○			
	MIST		○—○	○—○			

Washer switch

Terminal	d-5	d-2
Switch position		
OFF		
ON	○—○	○—○

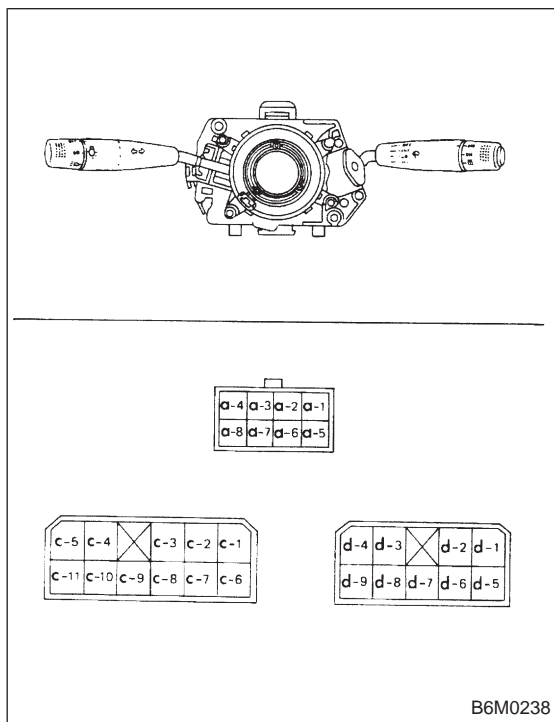

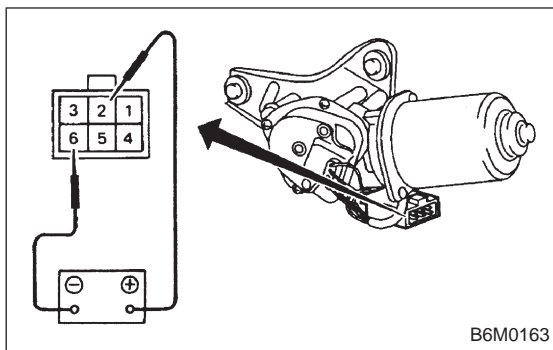

2. WIPER MOTOR

1) Check wiper motor operation at low speed.
Connect battery to wiper motor. Check wiper motor for proper operation at low speed.

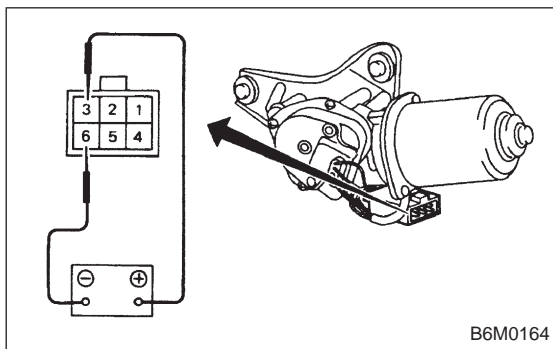

2) Check wiper motor operation at high speed.
Connect battery to wiper motor. Check wiper motor for proper operation at high speed.

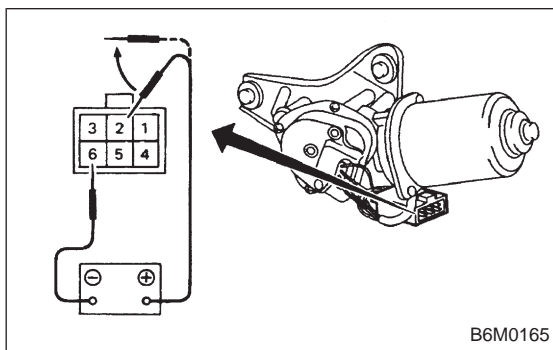

3) Check wiper motor for proper stoppage.
Connect battery to wiper motor. After operating wiper motor at low speed, disconnect battery to stop it.

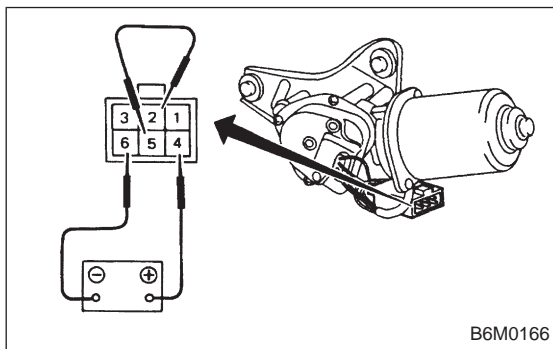

4) Reconnect battery and ensure that wiper motor stops at "AUTO STOP" after operating at low speed.

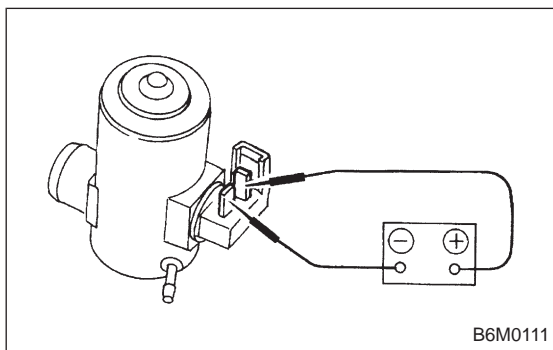

3. WASHER MOTOR

Apply battery voltage between terminals of washer motor connector and check that washer motor operates.

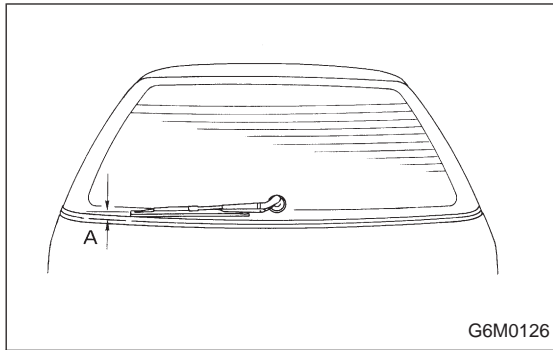

G6M0126

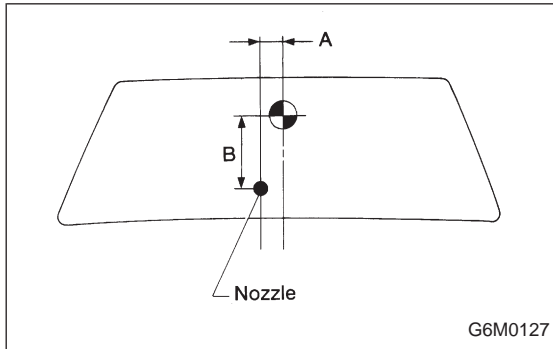

G6M0127

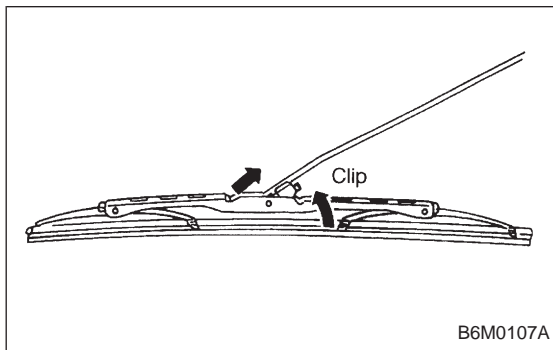

B6M0107A

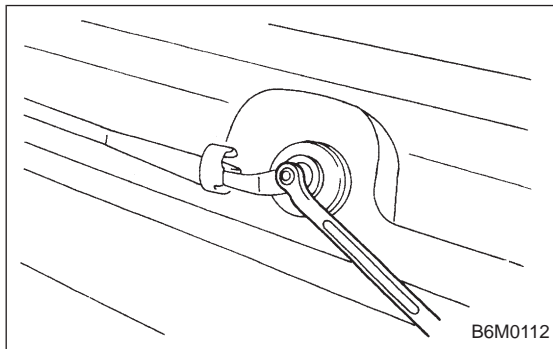

B6M0112

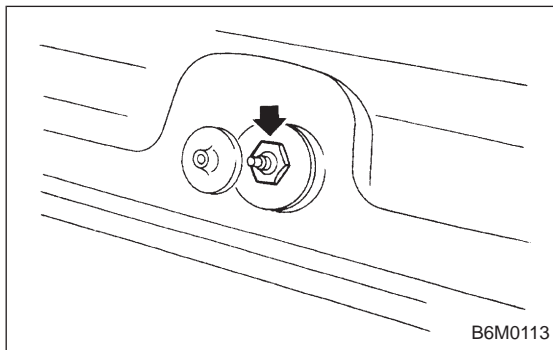

B6M0113

11. Rear Wiper and Washer

A: ON-CAR SERVICES

1. ADJUSTMENT

1) Adjust wiper blade in original position as shown in figure by changing wiper arm installation.

Original position:

A: 25 — 35 mm (0.98 — 1.38 in)

2) Adjust washer ejecting point on rear gate window as shown in figure when the vehicle stops.

Ejecting point:

A: 25 mm (0.98 in)

B: 200 — 300 mm (7.87 — 11.81 in)

B: REMOVAL AND INSTALLATION

1. BLADE

Pull out blade following the arrow direction, from arm while pushing up locking clip.

2. WIPER ARM

1) Remove head cover.

2) Remove nut and wiper arm.

Tightening torque:

$5.9 \pm 1.5 \text{ N}\cdot\text{m}$ ($0.6 \pm 0.15 \text{ kg}\cdot\text{m}$, $4.3 \pm 1.1 \text{ ft}\cdot\text{lb}$)

3. WIPER MOTOR

1) Remove cap and special nut.

CAUTION:

Be careful not to strike service tool against nozzle during removal.

Tightening torque:

$7.4 \pm 1.5 \text{ N}\cdot\text{m}$ ($0.75 \pm 0.15 \text{ kg}\cdot\text{m}$, $5.4 \pm 1.1 \text{ ft}\cdot\text{lb}$)

- 2) Remove rear gate trim. <Ref. to 5-2 [W3A1].>
- 3) Undo clips which secure harness, and disconnect connector of wiper motor.

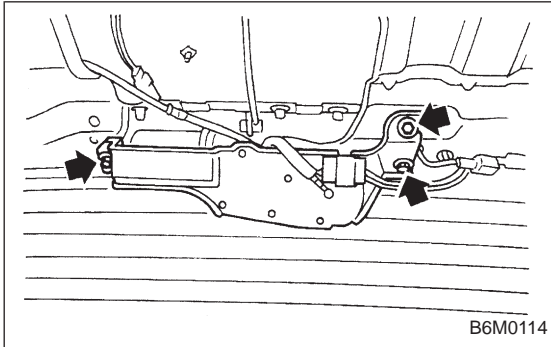

- 4) Separate washer hoses at joint.
- 5) Remove attaching screws and take out wiper motor assembly.

CAUTION:

Be careful not to damage O-ring when removing wiper motor assembly.

Tightening torque:

$5.9 \pm 1.5 \text{ N}\cdot\text{m}$ ($0.6 \pm 0.15 \text{ kg}\cdot\text{m}$, $4.3 \pm 1.1 \text{ ft}\cdot\text{lb}$)

4. WASHER TANK AND WASHER MOTOR

Refer to 6-2 [W10B4] as for removal and installation of washer tank and washer motor.

5. COMBINATION SWITCH

Refer to 6-2 [W4B3] as for removal and installation of combination switch.

C: DISASSEMBLY AND ASSEMBLY**1. COMBINATION SWITCH**

Refer to 6-2 [W4C1] as for disassembly and assembly of combination switch.

D: INSPECTION

1. COMBINATION SWITCH (ON-CAR)

- 1) Remove instrument panel lower cover.
- 2) Remove lower column cover.

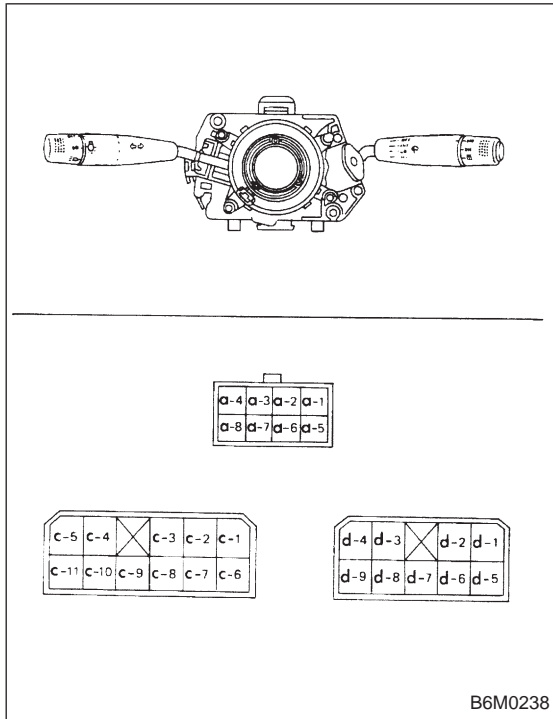

- 3) Unfasten holddown clip which secures harness, and disconnect connectors from body harness.
- 4) Set rear wiper and washer switch to each position and check continuity between terminals as indicated in table below:

Terminal	d-2	d-1	d-3
Switch position			
WASH	○	○	
OFF			
ON	○		○
WASH	○	○	○

2. WIPER MOTOR

- 1) Operational check

Connect battery to wiper motor and check operation of wiper motor.

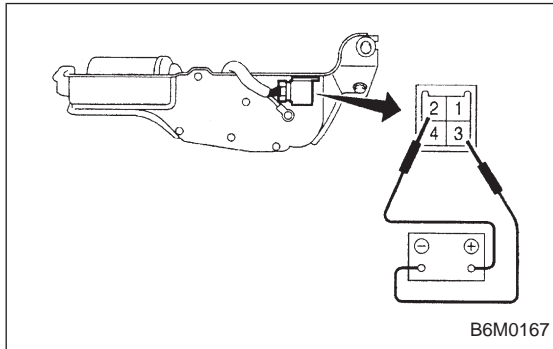

- 2) Check wiper motor for proper stoppage.

After operating wiper motor, disconnect battery from wiper motor.

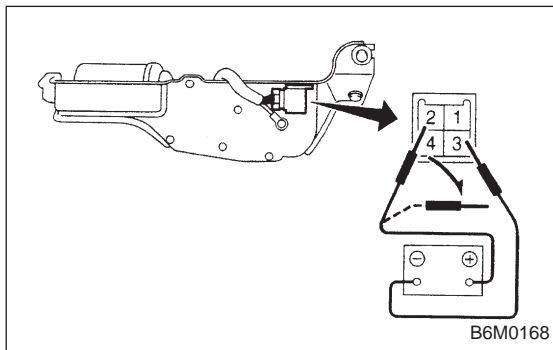

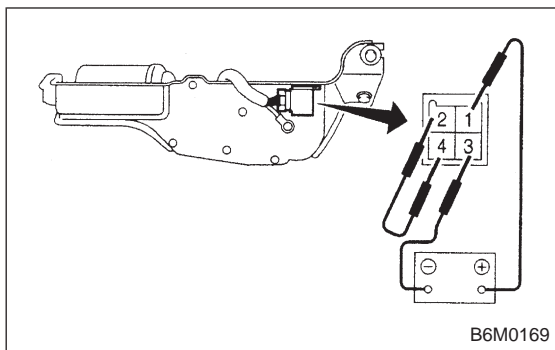

B6M0169

3) Reconnect battery and ensure that wiper motor stops at "AUTO STOP" after it has been operated.

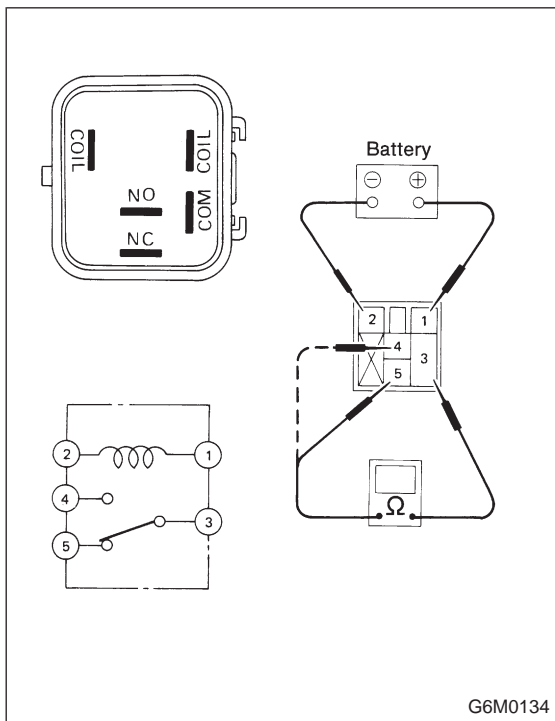

G6M0134

3. REAR WIPER RELAY

- 1) Connect battery to terminal No. 1 and ground terminal No. 2.
- 2) Check continuity between terminals as indicated in table below:

When current flows.	Between terminals No. 3 and No. 5	Continuity does not exist.
	Between terminals No. 3 and No. 4	Continuity exists.
When current does not flow.	Between terminals No. 3 and No. 5	Continuity exists.
	Between terminals No. 3 and No. 4	Continuity does not exist.
	Between terminals No. 1 and No. 2	Continuity exists.

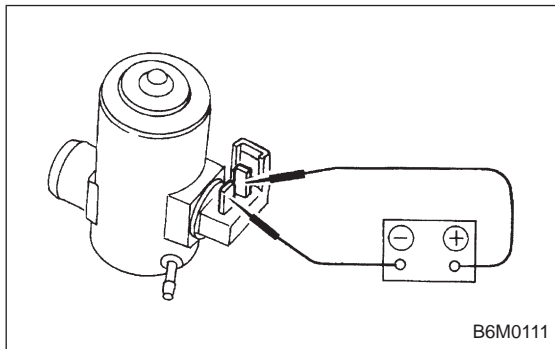

B6M0111

4. WASHER MOTOR

Apply battery voltage between terminals of washer motor connector and check that washer motor operates.

12. Rear Window Defogger

A: REMOVAL AND INSTALLATION

1. DEFOGGER SWITCH

- 1) Remove screws which secure meter visor.
- 2) Remove meter visor from instrument panel while disconnecting connectors.
- 3) Remove rear window defogger switch from meter visor.

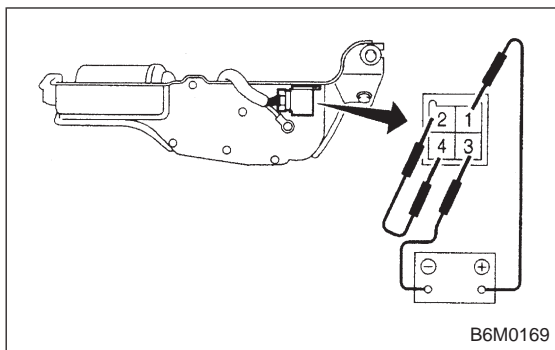

B6M0169

3) Reconnect battery and ensure that wiper motor stops at "AUTO STOP" after it has been operated.

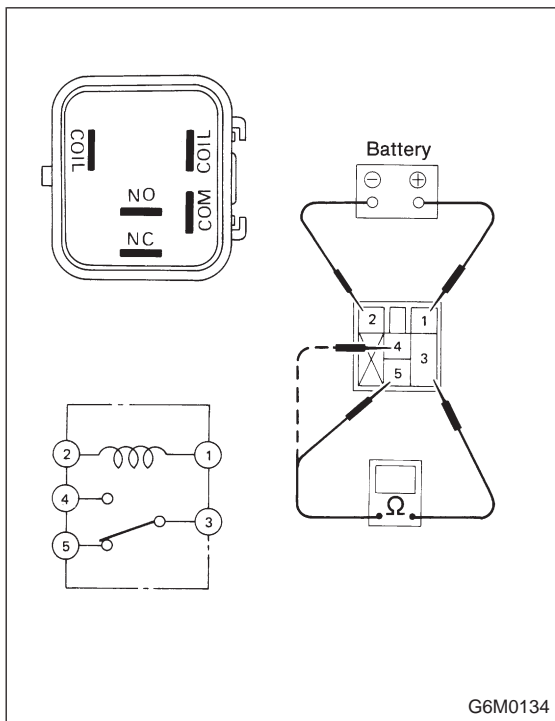

G6M0134

3. REAR WIPER RELAY

- 1) Connect battery to terminal No. 1 and ground terminal No. 2.
- 2) Check continuity between terminals as indicated in table below:

When current flows.	Between terminals No. 3 and No. 5	Continuity does not exist.
	Between terminals No. 3 and No. 4	Continuity exists.
When current does not flow.	Between terminals No. 3 and No. 5	Continuity exists.
	Between terminals No. 3 and No. 4	Continuity does not exist.
	Between terminals No. 1 and No. 2	Continuity exists.

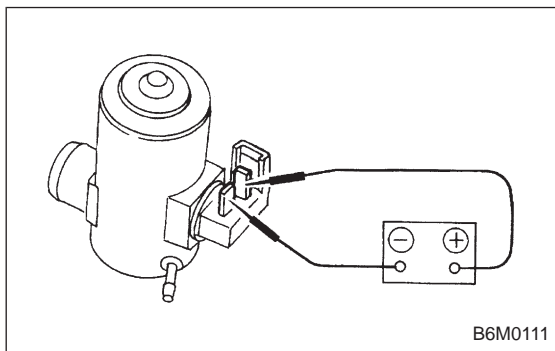

B6M0111

4. WASHER MOTOR

Apply battery voltage between terminals of washer motor connector and check that washer motor operates.

12. Rear Window Defogger

A: REMOVAL AND INSTALLATION

1. DEFOGGER SWITCH

- 1) Remove screws which secure meter visor.
- 2) Remove meter visor from instrument panel while disconnecting connectors.
- 3) Remove rear window defogger switch from meter visor.

12. Rear Window Defogger

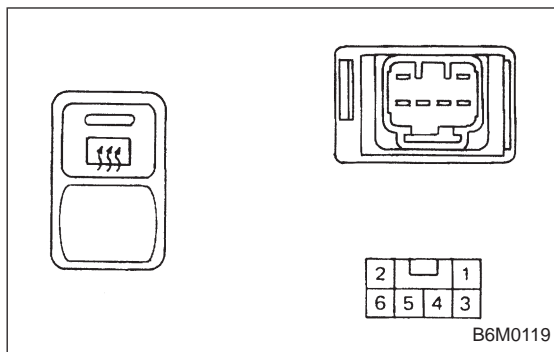

B6M0119

B: INSPECTION

1. DEFOGGER SWITCH

Move rear window defogger switch to each position and check continuity between terminals as indicated in table below:

Switch position	Terminal 3	Terminal 5	Terminal 1	Terminal 4	Terminal 2
OFF				○	○
ON	○	○	○	○	○

2. DEFOGGER RELAY

Check continuity between terminals as indicated in table below, when connecting the battery to terminal No. 1 and No. 3.

When current flows.	Between terminals No. 2 and No. 4	Continuity exists.
When current does not flow.	Between terminals No. 2 and No. 4	Continuity does not exist.
	Between terminals No. 1 and No. 3	Continuity exists.

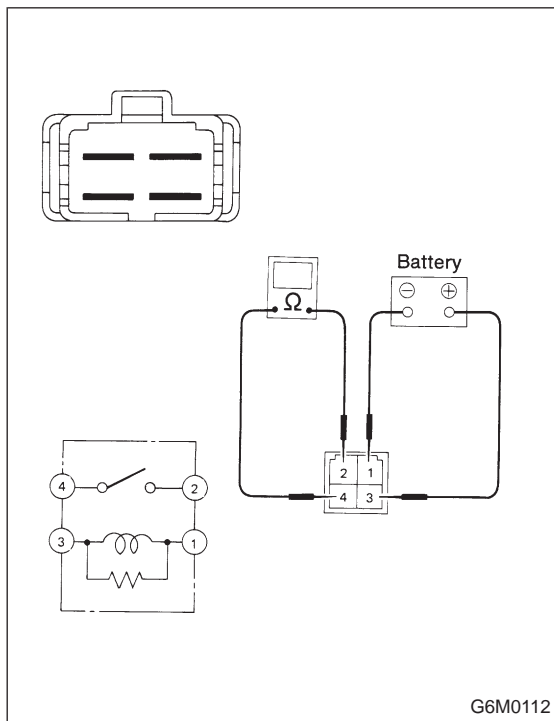

G6M0112

3. HEAT WIRES

- 1) Start the engine so that battery is being charged.
 - 2) Turn defogger switch to ON.
 - 3) Check each heat wire at its center position for discontinuity by setting direct current voltmeter.
- Normal indication is about 6 volts.

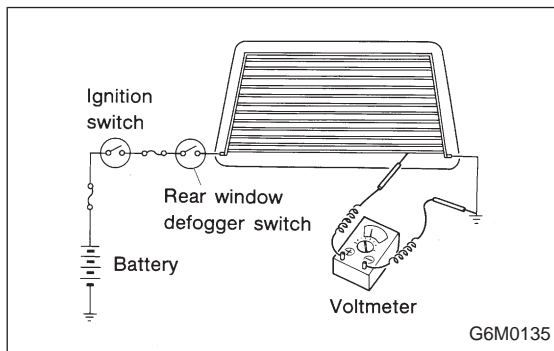

G6M0135

NOTE:

When measuring voltage, wind a piece of tin foil around the tip of the tester probe and press the foil against the wire with your finger.

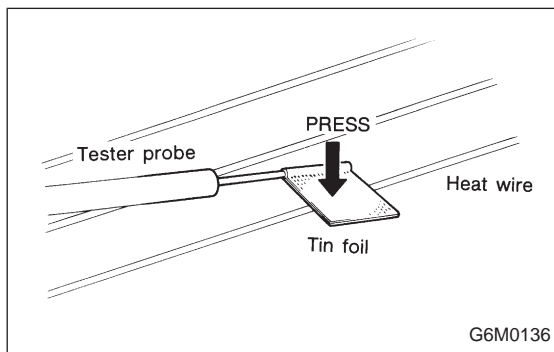

G6M0136

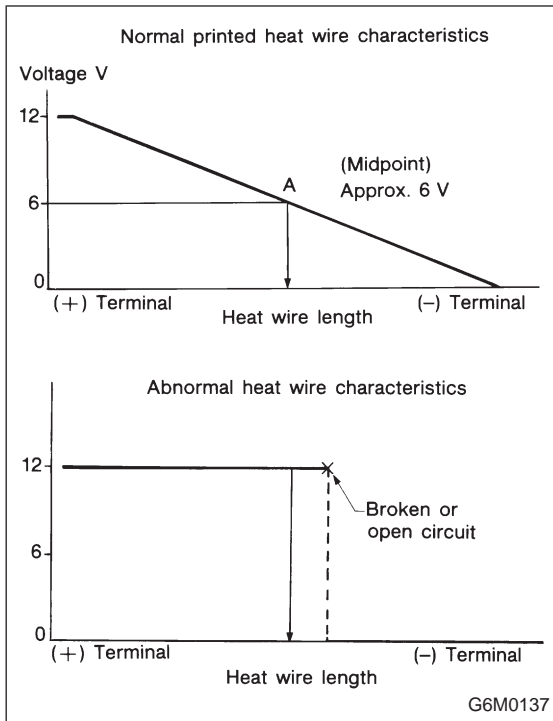

4) When tester indicates 12 volts when its probe reaches point "A", a broken circuit occurs between point "A" and the negative terminal. Slowly move tester probe toward the negative terminal while contacting it on heat wire to locate point where tester indication changes abruptly (0 volts). This is the point where a broken circuit occurs.

When tester indicates 0 volts when its probe reaches point "A", a broken circuit occurs between point "A" and the positive terminal. Locate a point where tester indication changes abruptly (12 volts) while slowly moving tester probe toward the positive terminal.

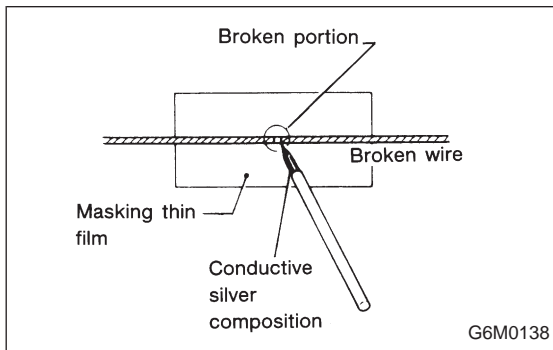

C: REPAIR

- 1) Clean broken wire and its surrounding area.
- 2) Cut off slit on (used) thin film by 0.5 mm (0.020 in) width and 10 mm (0.39 in) length.
- 3) Place the slit on glass along the broken wire, and deposit conductive silver composition (DUPONT No. 4817) on the broken portion.
- 4) Dry out the deposited portion.
- 5) Inspect the repaired wire for continuity.

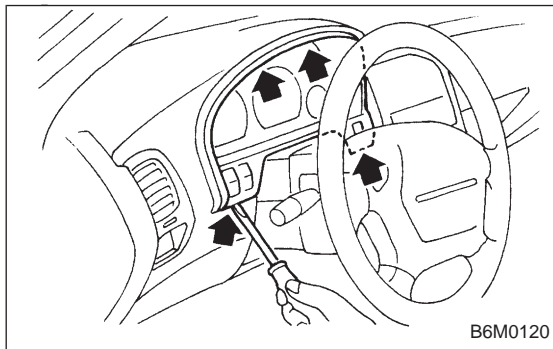

13. Combination Meter

A: REMOVAL AND INSTALLATION

1. COMBINATION METER

- 1) Move steering wheel fully down.
- 2) Remove screws which secure meter visor.
- 3) Remove visor from instrument panel.
- 4) Disconnect connectors from meter visor.

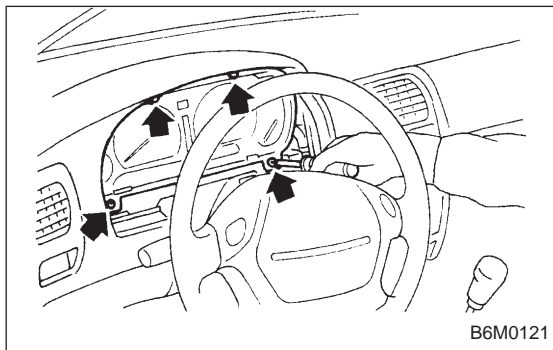

- 5) Remove screws which secure combination meter, and pull combination meter out.
- 6) Disconnect connectors from back of combination meter.

CAUTION:

When installing combination meter, be sure to connect connectors to backside of combination meter.

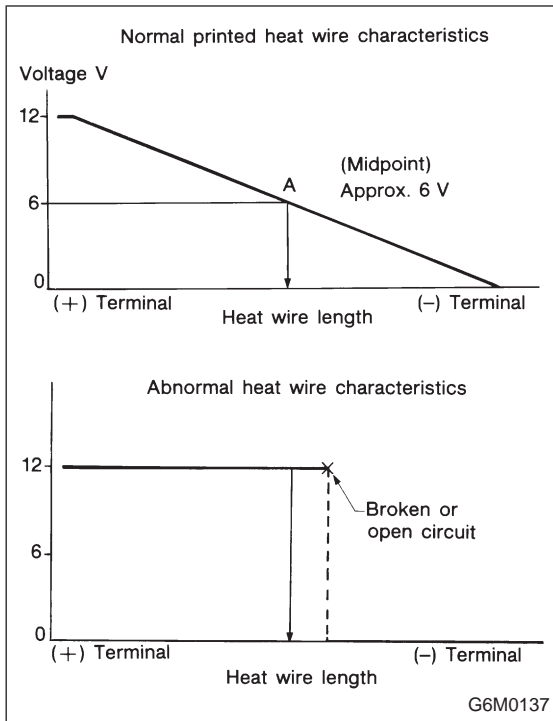

4) When tester indicates 12 volts when its probe reaches point "A", a broken circuit occurs between point "A" and the negative terminal. Slowly move tester probe toward the negative terminal while contacting it on heat wire to locate point where tester indication changes abruptly (0 volts). This is the point where a broken circuit occurs.

When tester indicates 0 volts when its probe reaches point "A", a broken circuit occurs between point "A" and the positive terminal. Locate a point where tester indication changes abruptly (12 volts) while slowly moving tester probe toward the positive terminal.

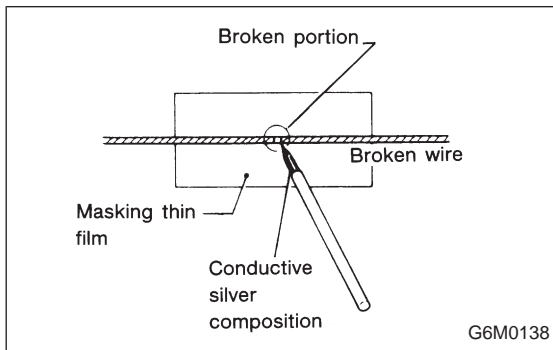

C: REPAIR

- 1) Clean broken wire and its surrounding area.
- 2) Cut off slit on (used) thin film by 0.5 mm (0.020 in) width and 10 mm (0.39 in) length.
- 3) Place the slit on glass along the broken wire, and deposit conductive silver composition (DUPONT No. 4817) on the broken portion.
- 4) Dry out the deposited portion.
- 5) Inspect the repaired wire for continuity.

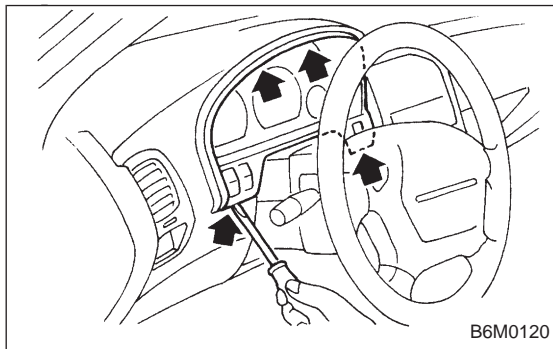

13. Combination Meter

A: REMOVAL AND INSTALLATION

1. COMBINATION METER

- 1) Move steering wheel fully down.
- 2) Remove screws which secure meter visor.
- 3) Remove visor from instrument panel.
- 4) Disconnect connectors from meter visor.

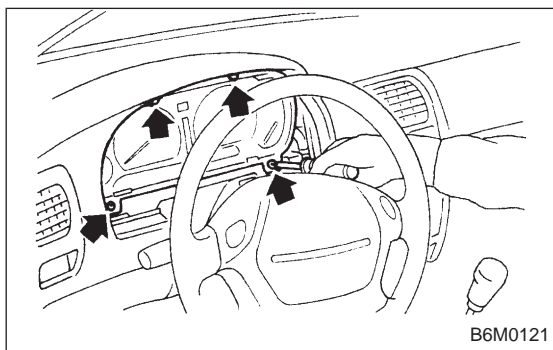

- 5) Remove screws which secure combination meter, and pull combination meter out.
- 6) Disconnect connectors from back of combination meter.

CAUTION:

When installing combination meter, be sure to connect connectors to backside of combination meter.

B: BULB REPLACEMENT

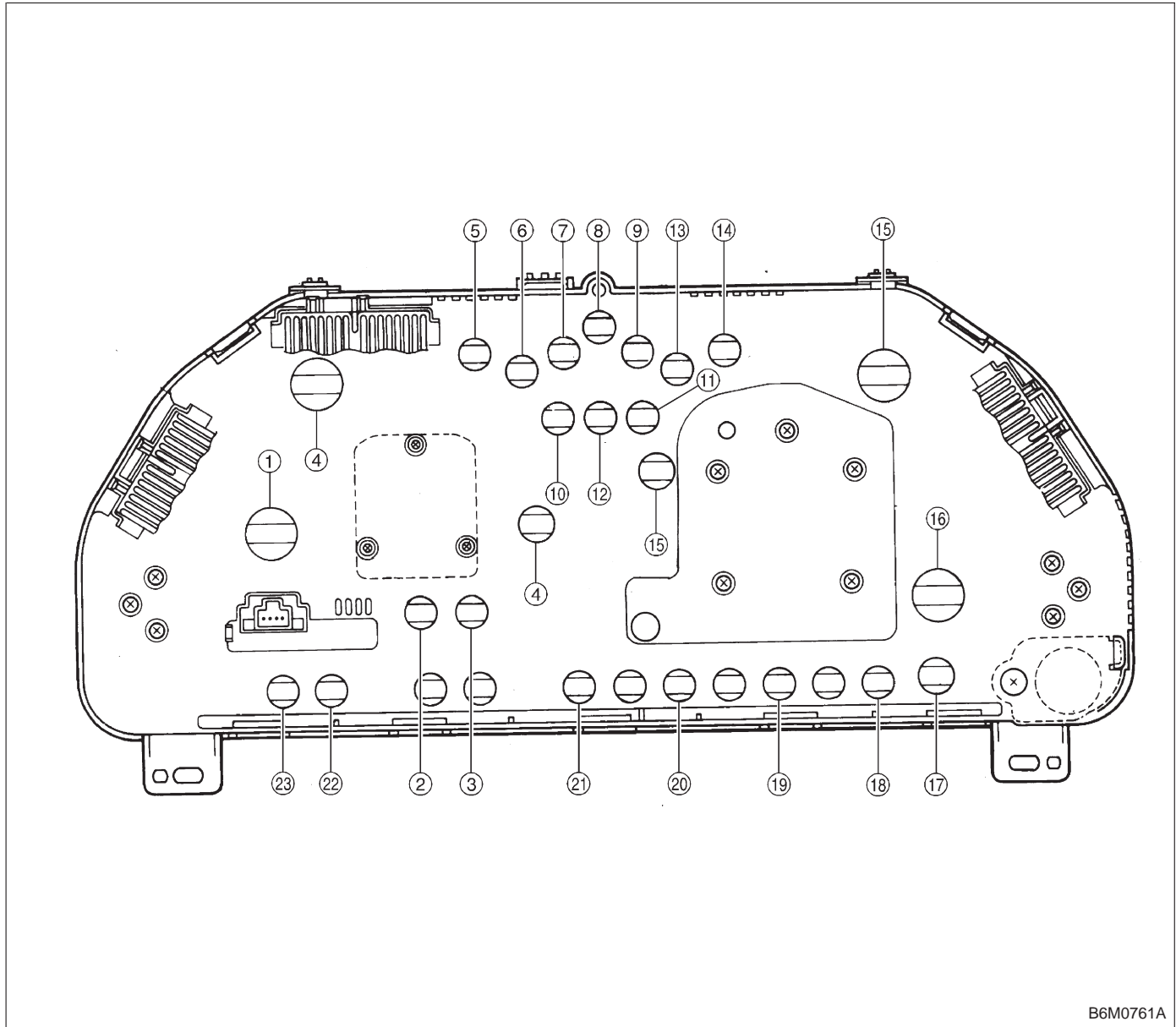

B6M0761A

- | | | |
|---|--|---|
| ① Tachometer and temperature gauge illumination | ⑥ Seat belt | ⑯ Speedometer and fuel gauge illumination |
| ② Oil pressure | ⑨ Door open (Front-Left) | ⑰ Low fuel |
| ③ CHECK ENGINE (Malfunction Indicator Light) | ⑩ Door open (Rear-Right) | ⑱ Charge |
| ④ Tachometer illumination | ⑪ Door open (Rear-Left) | ⑲ Brake fluid level/parking brake |
| ⑤ Turn signal (RH) | ⑫ Rear gate open (Wagon) | ⑳ FWD |
| ⑥ Headlight beam | ⑬ TCS (Operation indicator) (TAIWAN model) | ㉑ AT oil temperature |
| ⑦ Door open (Front-Right) | ⑭ Turn signal (LH) | ㉒ ABS |
| | ⑮ Speedometer illumination | ㉓ TCS (Warning) (TAIWAN model) |

14. Vehicle Speed Sensor 2

A: GENERAL PRECAUTIONS

- 1) Be careful not to drop or bump sensor as this may break built-in magnet.
- 2) Drive key is designed to separate from vehicle speed sensor 2. Be careful not to lose it or forget to install.
- 3) Vehicle speed sensor 2 is installed in part (which contains bearings, etc., finished to a high degree of accuracy). Do not allow foreign matter (filings, sand, etc.) to get into it.
- 4) When checking output of vehicle speed sensor 2 as a single unit, ensure test leads are connected to their correct terminals. Failure to do this may damage internal IC.
- 5) Discard vehicle speed sensor 2 after removal; replace with new one.

B: REMOVAL

CAUTION:

- Be careful when removing vehicle speed sensor 2 immediately after driving vehicle for a while, as temperature around it is high.
- Before removing vehicle speed sensor 2, clean dirt, etc. from surrounding areas. Take care not to allow foreign matter to get into mounting hole.

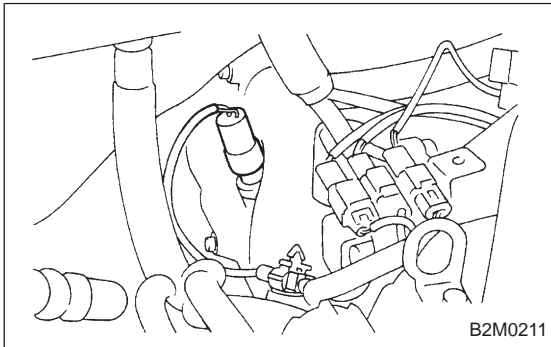

- 1) Remove collector cover.
- 2) Disconnect vehicle speed sensor 2 connector.
- 3) Turn and remove vehicle speed sensor 2.
- 4) Remove key and packing.

C: INSTALLATION**CAUTION:**

- Ensure sensor mounting hole is clean and free of foreign matter.
- Apply grease to tip end of key to prevent key from falling off sensor.
- Align tip end of key with key groove on end of speedometer shaft during installation.

1) Hand tighten vehicle speed sensor 2, then tighten it using suitable tool.

Tightening torque required for sensor to reach bottom of transmission is as follows:

Tightening torque:

0.39 — 0.88 N·m (4.0 — 9.0 kg-cm, 3.5 — 7.8 in-lb)

CAUTION:

- When torque must be applied that exceeds 0.88 N·m (9.0 kg-cm, 7.8 in-lb), the key and key groove on end of speedometer may not be aligned properly. Remove the key, align it correctly and reassemble.
- Sensor threads are secured by Locktite. The reassembly must be completed within 5 minutes before Locktite dries.

2) Tighten vehicle speed sensor 2 further to specified torque.

Tightening torque:

5.9±1.5 N·m (60±15 kg-cm, 52±13 in-lb)

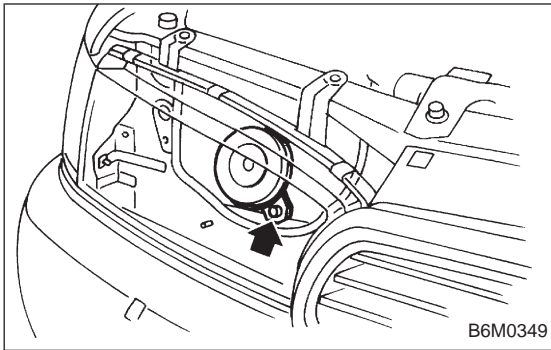

15. Horn and Cigarette Lighter

A: REMOVAL AND INSTALLATION

1. HORN

- 1) Open the engine hood.
- 2) Disconnect connector of horn.
- 3) Remove the horn.

Tightening torque:

$18\pm 5 \text{ N}\cdot\text{m}$ ($1.8\pm 0.5 \text{ kg}\cdot\text{m}$, $13.0\pm 3.6 \text{ ft}\cdot\text{lb}$)

CAUTION:

After installing horn, connect connector, fit firmly wiring harness to prevent from disconnecting due to vibration.

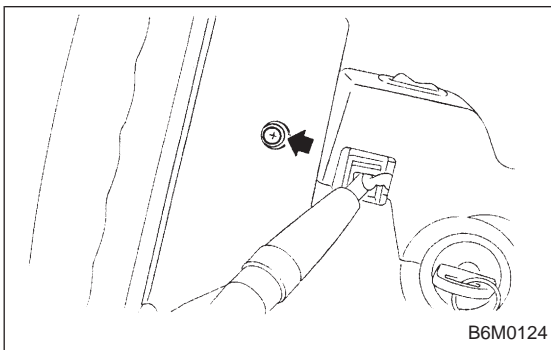

2. HORN SWITCH (HORN PAD)

- 1) Remove screw which secures horn switch (steering pad) to the base of steering wheel.
- 2) Remove horn switch (steering pad) from steering wheel while disconnecting connector.

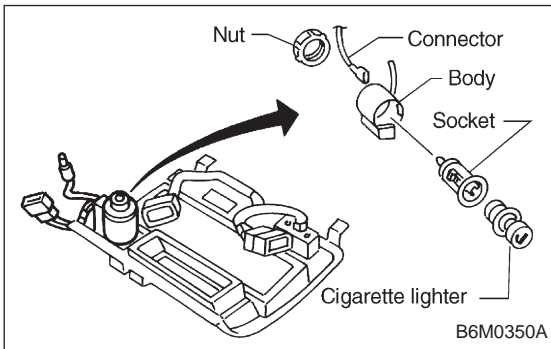

3. CIGARETTE LIGHTER

- 1) Remove center panel from instrument panel. <Ref. to 5-4 [W1A0].>
- 2) Disconnect connector from cigarette lighter.
- 3) Turn illumination socket 45° counterclockwise and remove it.
- 4) Loosen nut, and then remove cigarette lighter body.

CAUTION:

● Align socket with cutout portion of instrument panel during installation.

● In case of replacing cigarette lighter, use genuine part only and always replace both plug and socket combination.

B: INSPECTION**1. HORN SWITCH**

Ensure that horn switch is free from the following defects:

- 1) Burned or shorted contacts
- 2) Broken or weak spring
- 3) Damaged harness
- 4) Worn or corroded mating surface of horn plate

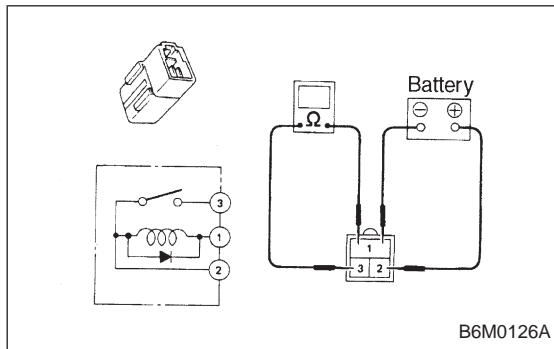
**2. HORN RELAY**

Check continuity between terminals as indicated in table below, when connecting the battery to terminals No. 1 and No. 2.

When current flows.	Between terminals No. 2 and No. 3	Continuity exists.
When current does not flow.	Between terminals No. 2 and No. 3	Continuity does not exist.
	Between terminals No. 1 and No. 2	Continuity exists.

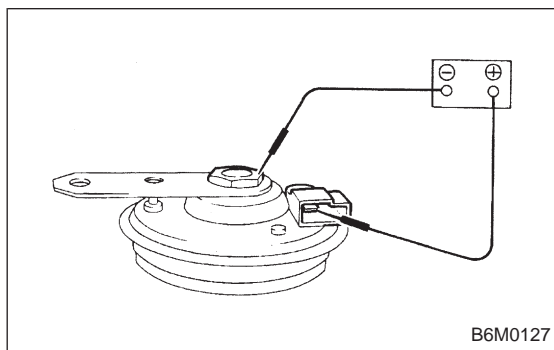
**3. HORN**

Make sure that horn sounds when battery voltage is applied between connector terminal and horn body.

4. CIGARETTE LIGHTER

- 1) Remove plug. Then, check element's contact for wear, and element for accumulation of ashes, foreign particles, etc.
- 2) Check element for discontinuity.
- 3) Remove socket and clean element. Then, check for wear or foreign particles on element's contact and mating surface.
- 4) Ensure that cigarette lighter returns within 20 seconds after it is turned to ON.

16. Power Window**A: REMOVAL AND INSTALLATION****1. MAIN SWITCH, SUB SWITCH AND POWER WINDOW MOTOR**

Refer to 5-2 [W2A2] as for removal and installation of power window main switch, sub switch and motor.

NOTE:

To remove the power window motor, it is necessary to disassemble the door component parts.

B: INSPECTION**1. HORN SWITCH**

Ensure that horn switch is free from the following defects:

- 1) Burned or shorted contacts
- 2) Broken or weak spring
- 3) Damaged harness
- 4) Worn or corroded mating surface of horn plate

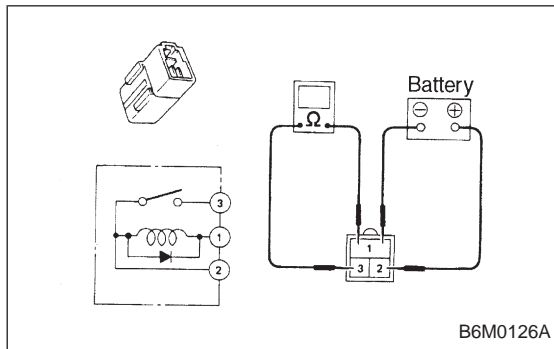
**2. HORN RELAY**

Check continuity between terminals as indicated in table below, when connecting the battery to terminals No. 1 and No. 2.

When current flows.	Between terminals No. 2 and No. 3	Continuity exists.
When current does not flow.	Between terminals No. 2 and No. 3	Continuity does not exist.
	Between terminals No. 1 and No. 2	Continuity exists.

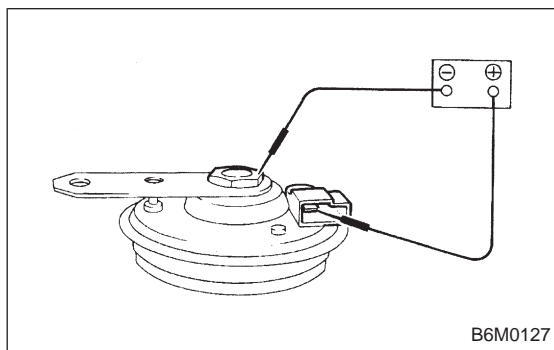
**3. HORN**

Make sure that horn sounds when battery voltage is applied between connector terminal and horn body.

4. CIGARETTE LIGHTER

- 1) Remove plug. Then, check element's contact for wear, and element for accumulation of ashes, foreign particles, etc.
- 2) Check element for discontinuity.
- 3) Remove socket and clean element. Then, check for wear or foreign particles on element's contact and mating surface.
- 4) Ensure that cigarette lighter returns within 20 seconds after it is turned to ON.

16. Power Window**A: REMOVAL AND INSTALLATION****1. MAIN SWITCH, SUB SWITCH AND POWER WINDOW MOTOR**

Refer to 5-2 [W2A2] as for removal and installation of power window main switch, sub switch and motor.

NOTE:

To remove the power window motor, it is necessary to disassemble the door component parts.

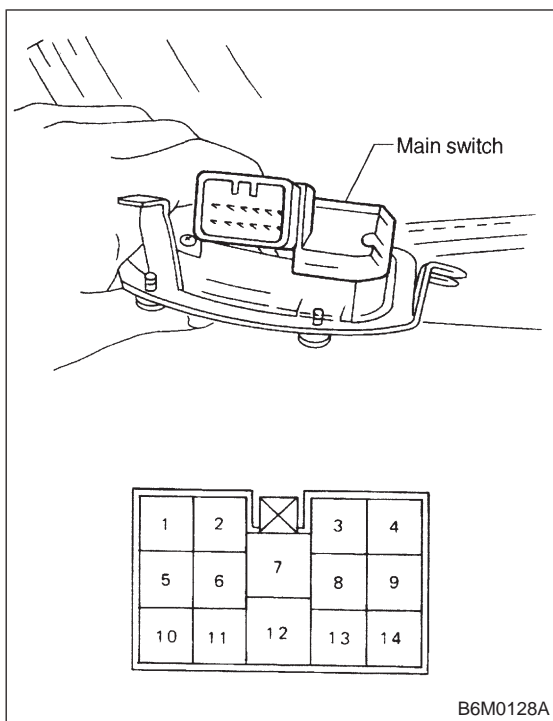

B: INSPECTION

1. MAIN SWITCH

Set power window main switch to each position and check continuity between terminals as indicated in table below:

LHD model

Window lock switch	Switch	Front RH				Front LH				Rear RH				Rear LH			
	Position	7	14	9	12	7	13	8	12	7	6	11	12	7	10	5	12
NORMAL	UP	<input type="radio"/>	<input type="radio"/>	<input type="radio"/>	<input type="radio"/>	<input type="radio"/>	<input type="radio"/>	<input type="radio"/>	<input type="radio"/>	<input type="radio"/>	<input type="radio"/>	<input type="radio"/>	<input type="radio"/>	<input type="radio"/>	<input type="radio"/>	<input type="radio"/>	<input type="radio"/>
	OFF		<input type="radio"/>	<input type="radio"/>	<input type="radio"/>		<input type="radio"/>	<input type="radio"/>	<input type="radio"/>		<input type="radio"/>	<input type="radio"/>	<input type="radio"/>		<input type="radio"/>	<input type="radio"/>	<input type="radio"/>
	DOWN	<input type="radio"/>		<input type="radio"/>		<input type="radio"/>		<input type="radio"/>		<input type="radio"/>		<input type="radio"/>		<input type="radio"/>		<input type="radio"/>	
LOCK	UP	<input type="radio"/>	<input type="radio"/>			<input type="radio"/>	<input type="radio"/>	<input type="radio"/>	<input type="radio"/>	<input type="radio"/>	<input type="radio"/>			<input type="radio"/>	<input type="radio"/>		
	OFF		<input type="radio"/>	<input type="radio"/>			<input type="radio"/>	<input type="radio"/>	<input type="radio"/>		<input type="radio"/>	<input type="radio"/>			<input type="radio"/>	<input type="radio"/>	
	DOWN	<input type="radio"/>		<input type="radio"/>		<input type="radio"/>		<input type="radio"/>		<input type="radio"/>		<input type="radio"/>		<input type="radio"/>		<input type="radio"/>	

RHD model

Window lock switch	Switch	Front RH				Front LH				Rear RH				Rear LH			
	Position	7	11	6	12	7	10	5	12	7	9	14	12	7	13	8	12
AUTO UP		<input type="radio"/>	<input type="radio"/>	<input type="radio"/>	<input type="radio"/>												
UP		<input type="radio"/>	<input type="radio"/>	<input type="radio"/>	<input type="radio"/>	<input type="radio"/>	<input type="radio"/>	<input type="radio"/>	<input type="radio"/>	<input type="radio"/>	<input type="radio"/>	<input type="radio"/>	<input type="radio"/>	<input type="radio"/>	<input type="radio"/>	<input type="radio"/>	<input type="radio"/>
OFF			<input type="radio"/>	<input type="radio"/>	<input type="radio"/>		<input type="radio"/>	<input type="radio"/>	<input type="radio"/>		<input type="radio"/>	<input type="radio"/>	<input type="radio"/>		<input type="radio"/>	<input type="radio"/>	<input type="radio"/>
DOWN		<input type="radio"/>		<input type="radio"/>		<input type="radio"/>		<input type="radio"/>		<input type="radio"/>		<input type="radio"/>		<input type="radio"/>		<input type="radio"/>	
AUTO DOWN		<input type="radio"/>		<input type="radio"/>													

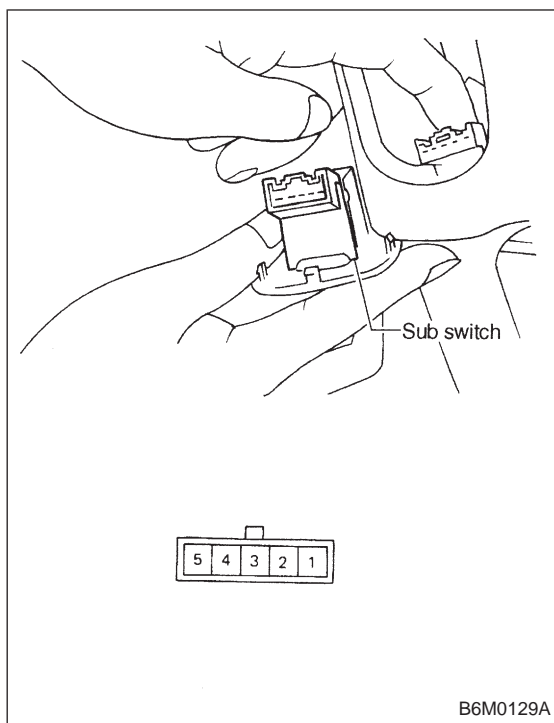

B6M0129A

2. SUB SWITCH

Set power window sub switch to each position and check continuity between terminals as indicated in table below:

Terminal Switch position	5	1	3	4	2
UP	○		○	○	○
↕					
OFF		○	○	○	○
↕					
DOWN	○	○		○	○

3. POWER WINDOW MOTOR

- 1) Make sure that power window motor rotates properly when battery voltage is applied to terminals of motor connector.
- 2) Change polarity of battery connections to terminals to ensure that motor rotates in reverse direction.

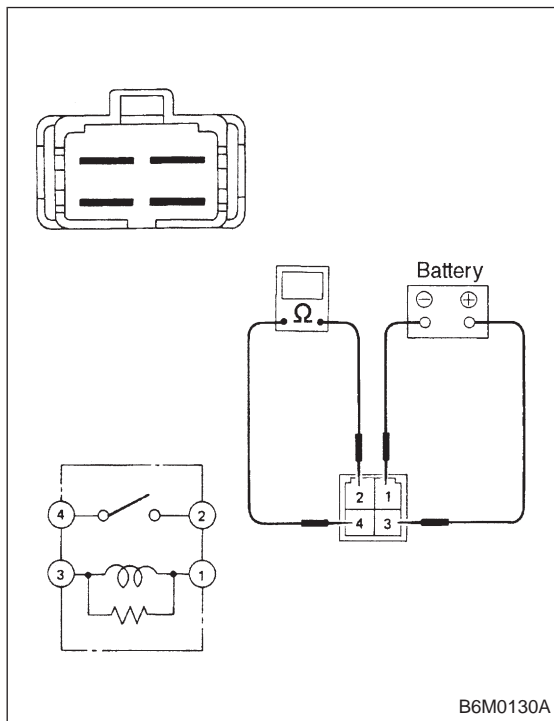

B6M0130A

4. POWER WINDOW RELAY

Check continuity between terminals as indicated in table below, when connecting the battery to terminal No. 1 and No. 3.

When current flows.	Between terminals No. 2 and No. 4	Continuity exists.
When current does not flow.	Between terminals No. 2 and No. 4	Continuity does not exist.
	Between terminals No. 1 and No. 3	Continuity exists.

17. Power Door Lock

A: REMOVAL AND INSTALLATION

1. FRONT AND REAR DOOR, AND REAR GATE LOCK ACTUATOR

Refer to 5-2 [W2A7] as for removal and installation of front door lock actuator, rear door lock actuators, and rear gate lock actuator.

NOTE:

To remove and install the actuators, it is necessary to disassemble the door component parts.

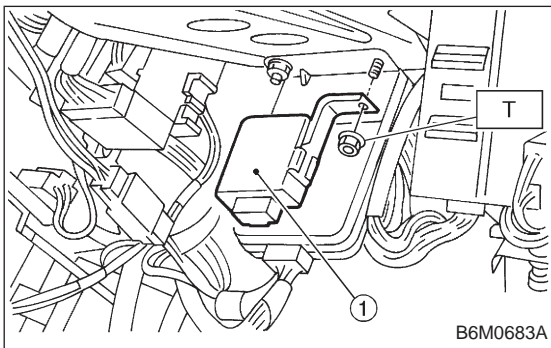
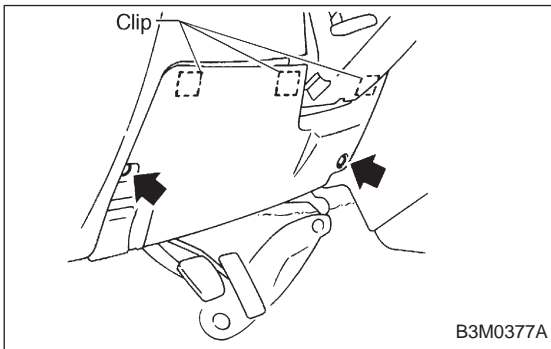
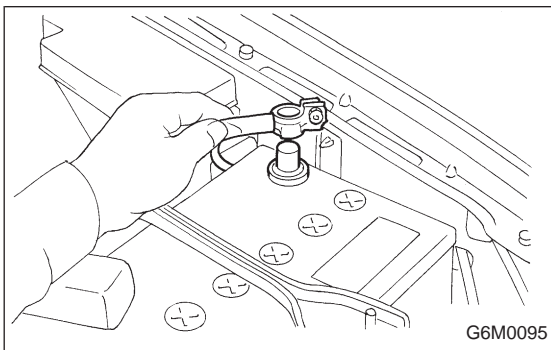

2. DOOR LOCK TIMER

1) Disconnect battery ground cable.

2) Remove lower cover and then disconnect connector.

3) Remove door lock timer ① while disconnecting connector.

4) Installation is in the reverse order of removal.

Tightening torque:

T: 7.4±2.5 N·m (0.75±0.25 kg-m, 5.4±1.8 ft-lb)

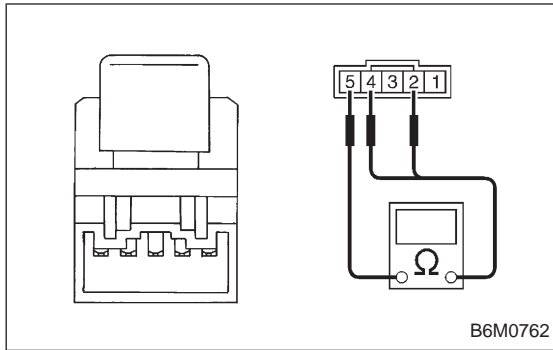
**B: INSPECTION****1. DOOR LOCK SWITCH (DRIVER'S AND FRONT PASSENGER'S DOOR)**

- 1) Remove door trim panel. <Ref. to 5-2 [W2A2].>
- 2) Set switch to each position and check continuity between terminals as indicated in table below:

Terminal Switch position	5	4	2
UNLOCK	○—	○—	
LOCK	○—		○—

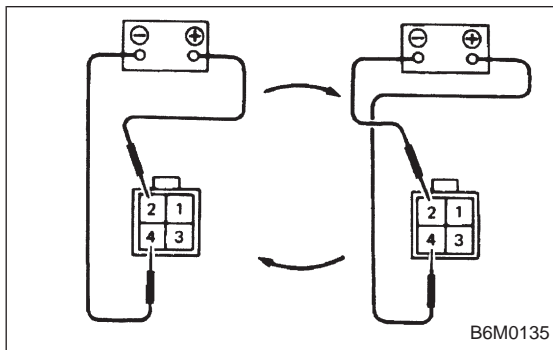
**2. ACTUATOR**

- 1) Remove door trim panel. <Ref. to 5-2 [W2A2].>
- 2) Disconnect connector of actuator.
- 3) Make sure that door link moves to LOCK or UNLOCK position when battery voltage is applied between terminals as described below:
 - Connect battery positive (+) terminal to terminal No. 2, and negative (-) terminal to terminal No. 4 at a moment.
 - Connect battery positive (+) terminal to terminal No. 4, and negative terminal (-) to terminal No. 2 at a moment.

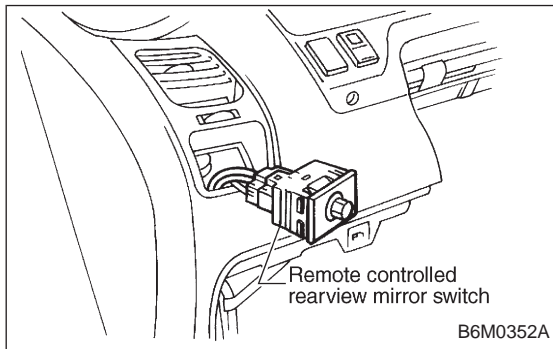
**18. Remote Controlled Rearview Mirror****A: REMOVAL AND INSTALLATION****1. REMOTE CONTROLLED REARVIEW MIRROR SWITCH**

- 1) Remove rearview mirror switch from instrument panel by using a small standard screwdriver.

CAUTION:

Do not pry rearview mirror switch forcefully as this may scratch instrument panel.

- 2) Remove rearview mirror switch while disconnecting connector.

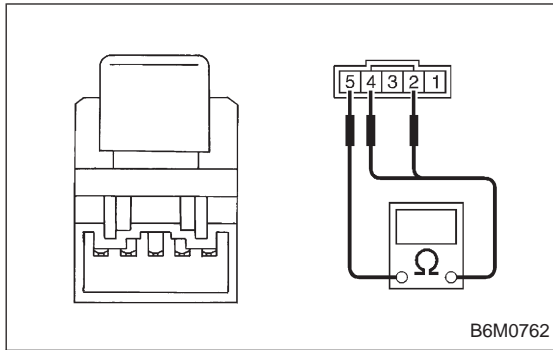
**B: INSPECTION****1. DOOR LOCK SWITCH (DRIVER'S AND FRONT PASSENGER'S DOOR)**

- 1) Remove door trim panel. <Ref. to 5-2 [W2A2].>
- 2) Set switch to each position and check continuity between terminals as indicated in table below:

Terminal Switch position	5	4	2
UNLOCK	○—	○—	
LOCK	○—		○—

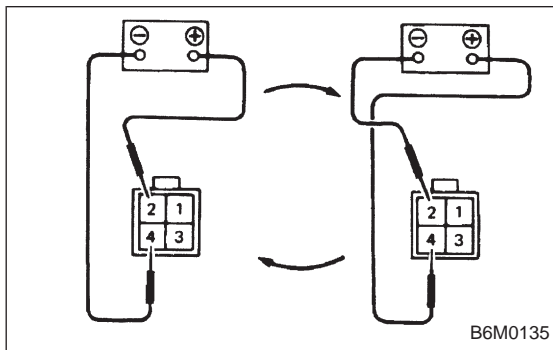
**2. ACTUATOR**

- 1) Remove door trim panel. <Ref. to 5-2 [W2A2].>
- 2) Disconnect connector of actuator.
- 3) Make sure that door link moves to LOCK or UNLOCK position when battery voltage is applied between terminals as described below:
 - Connect battery positive (+) terminal to terminal No. 2, and negative (-) terminal to terminal No. 4 at a moment.
 - Connect battery positive (+) terminal to terminal No. 4, and negative terminal (-) to terminal No. 2 at a moment.

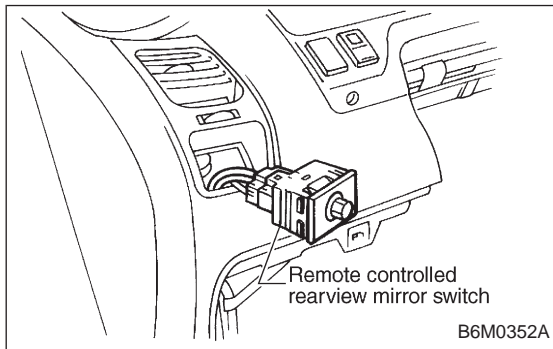
**18. Remote Controlled Rearview Mirror****A: REMOVAL AND INSTALLATION****1. REMOTE CONTROLLED REARVIEW MIRROR SWITCH**

- 1) Remove rearview mirror switch from instrument panel by using a small standard screwdriver.

CAUTION:

Do not pry rearview mirror switch forcefully as this may scratch instrument panel.

- 2) Remove rearview mirror switch while disconnecting connector.

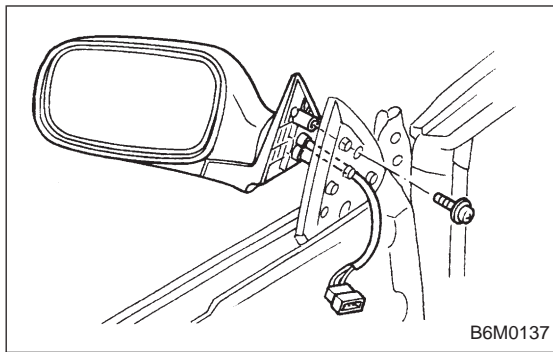

2. REARVIEW MIRROR

- 1) Remove door trim panel. <Ref. to 5-2 [W2A2].>
- 2) Disconnect connector of rearview mirror.
- 3) Remove screws which secure rearview mirror, and then remove rearview mirror.

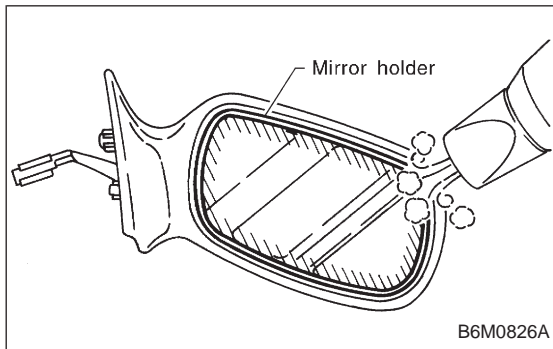

3. MIRROR PLATE

- 1) Remove rearview mirror. <Ref. to 6-2 [W18A2].>
- 2) Warm around the mirror holder by hair dryer.

CAUTION:

The mirror holder will become extremely hot. Avoid carelessly touching it.

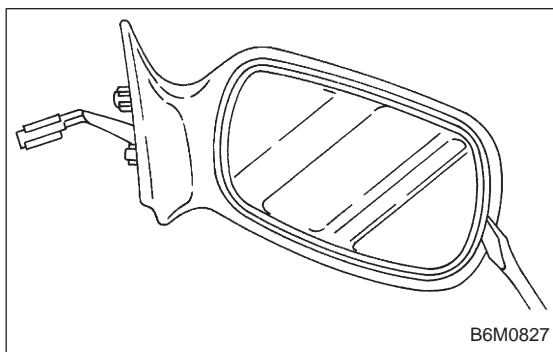

- 3) Remove mirror plate while lifting the mirror holder using a flat bladed screwdriver.

NOTE:

When removing mirror plate in vehicles with mirror heater, disconnect mirror connector which is on the back side.

- 4) Installation is in the reverse order of removal.

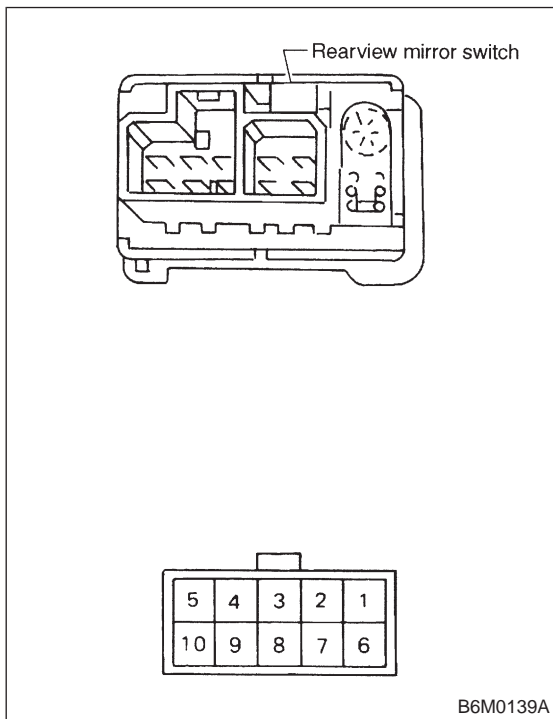

B: INSPECTION

1. REARVIEW MIRROR SWITCH

Move rearview mirror switch to each position and check continuity between terminals as indicated in table below:

Terminal	Mirror switch					Left/Right changing switch		
	OFF	Right	Left	Up	Down	Left	N	Right
7						○		
9							○	
6								○
8								○
2		○	○	○	○			○
1		○	○	○	○	○		○
4		○	○	○	○	○		○
3								

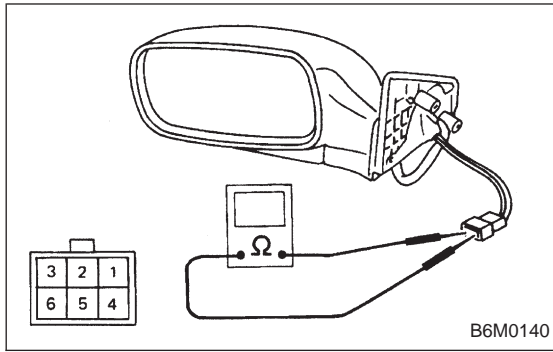

2. REARVIEW MIRROR

Check to ensure that rearview mirror moves properly when battery voltage is applied to terminals as indicated in table below:

Operation	Terminal connection	
	(+)	(-)
UP	3	1
DOWN	1	3
RIGHT	1	2
LEFT	2	1

19. Sunroof

A: REMOVAL AND INSTALLATION

1. SUNROOF AND SUNROOF MOTOR

Refer to 5-1 [W16A0] as for removal and installation of sunroof system.

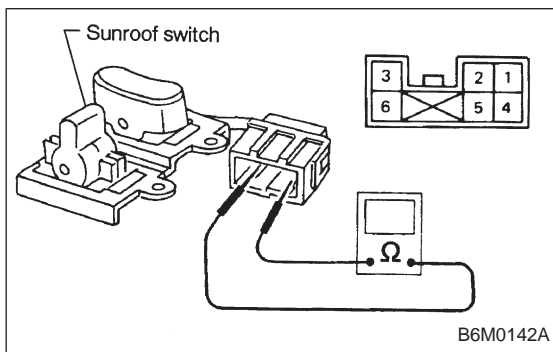
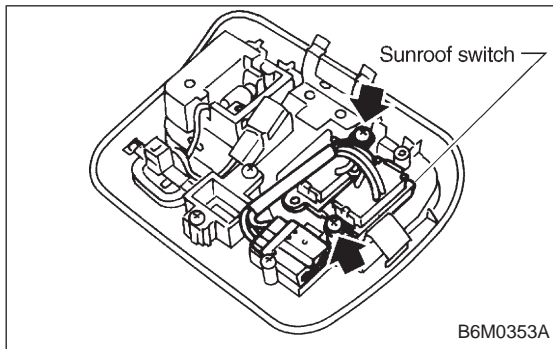

2. SUNROOF SWITCH

NOTE:

The sunroof switch is installed in spot light body.

- 1) Pry spot light lens off using a screwdriver.
- 2) Remove screws which secure spot light body.
- 3) Remove spot light body while disconnecting connectors.
- 4) Remove screw which secures sunroof switch, and then remove sunroof switch.

B: INSPECTION

1. SUNROOF SWITCH

Set sunroof switch to each position and check continuity between terminals as indicated in table below:

Switch position	Terminal 4	Terminal 3	Terminal 6	Terminal 5	Terminal 2
Open	○	○			
Close	○		○		
Tilt up	○			○	
Tilt down	○				○

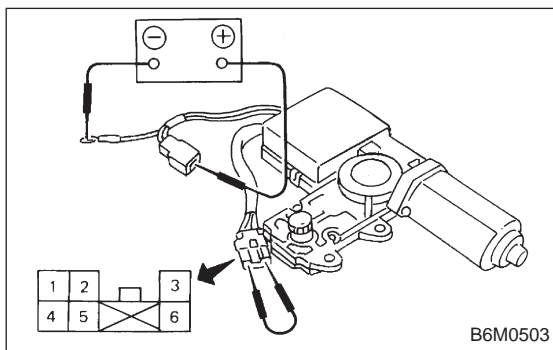

2. SUNROOF MOTOR

- 1) Apply battery voltage between 1-pin connector and body ground wire.
- 2) Make sure that sunroof motor moves when connecting terminals as described below:

- Connect between terminals No. 3 and 4 (OPEN)
- Connect between terminals No. 6 and 4 (CLOSE)
- Connect between terminals No. 5 and 4 (TILT UP)
- Connect between terminals No. 2 and 4 (TILT DOWN)

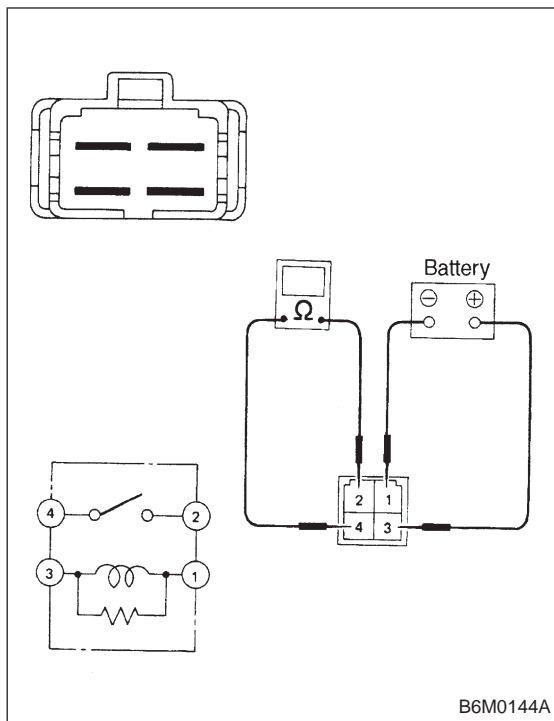

3. SUNROOF RELAY

Check continuity between terminals as indicated in table below, when battery voltage is applied between terminals No. 1 and No. 3.

When current flows.	Between terminals No. 2 and No. 4	Continuity exists.
When current does not flow.	Between terminals No. 2 and No. 4	Continuity does not exist.
	Between terminals No. 1 and No. 3	Continuity exists.

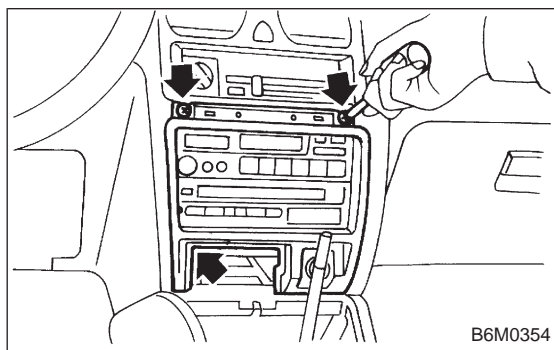

20. Radio, Speaker and Antenna

A: REMOVAL AND INSTALLATION

1. RADIO BODY

- 1) Remove hand brake cover.
- 2) Remove console cover.
- 3) Remove screws which secure center panel. Remove center panel.
- 4) Remove fitting screws, and slightly pull radio out of instrument panel.
- 5) Disconnect connectors and antenna feeder cord.

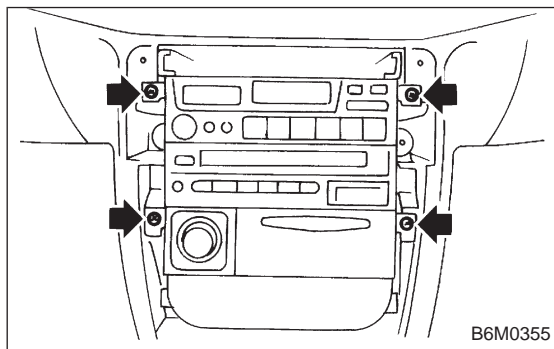

2. FRONT SPEAKER

- 1) Remove gusset speaker from behind the rearview mirror while disconnecting connector.
- 2) Remove door trim panel. <Ref. to 5-2 [W2A2].>

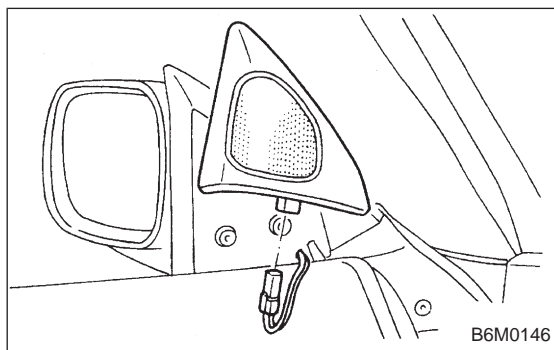

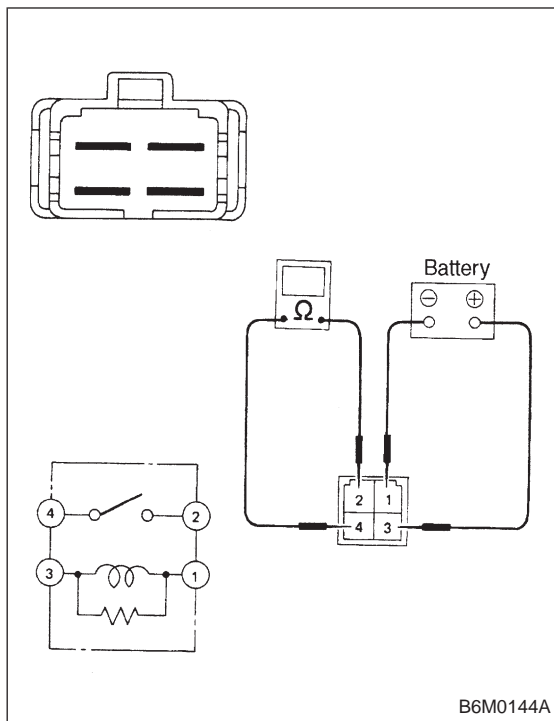

3. SUNROOF RELAY

Check continuity between terminals as indicated in table below, when battery voltage is applied between terminals No. 1 and No. 3.

When current flows.	Between terminals No. 2 and No. 4	Continuity exists.
When current does not flow.	Between terminals No. 2 and No. 4	Continuity does not exist.
	Between terminals No. 1 and No. 3	Continuity exists.

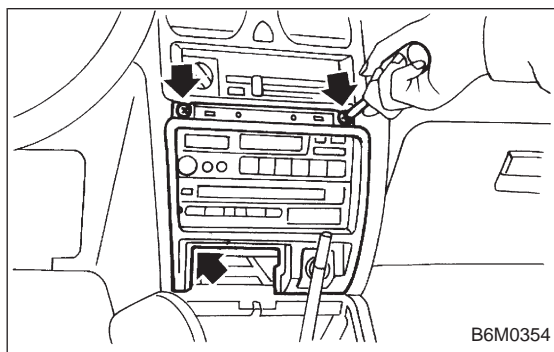

20. Radio, Speaker and Antenna

A: REMOVAL AND INSTALLATION

1. RADIO BODY

- 1) Remove hand brake cover.
- 2) Remove console cover.
- 3) Remove screws which secure center panel. Remove center panel.
- 4) Remove fitting screws, and slightly pull radio out of instrument panel.
- 5) Disconnect connectors and antenna feeder cord.

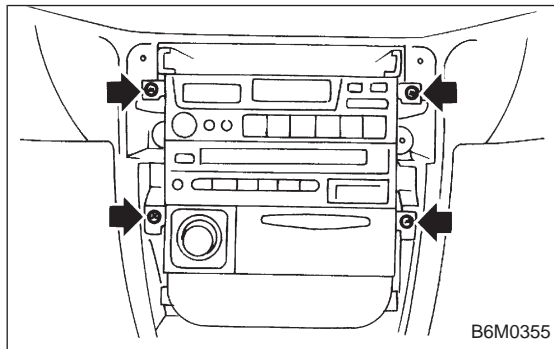

2. FRONT SPEAKER

- 1) Remove gusset speaker from behind the rearview mirror while disconnecting connector.
- 2) Remove door trim panel. <Ref. to 5-2 [W2A2].>

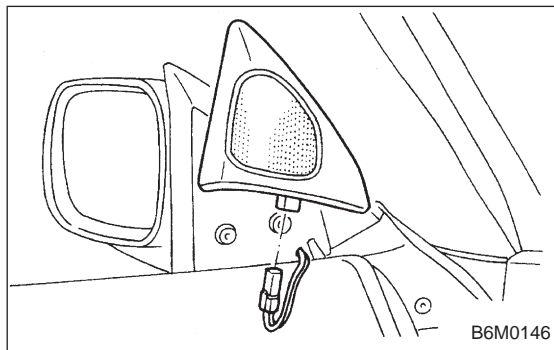

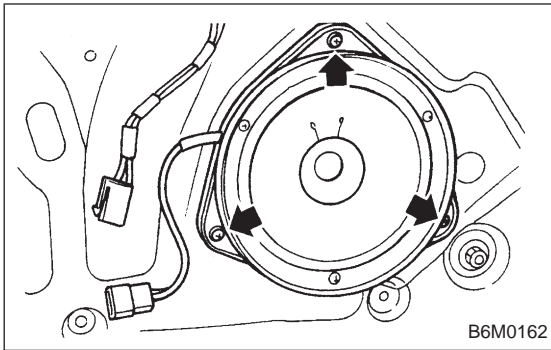

- 3) Disconnect connector from speaker.
- 4) Remove screws which secure the speaker.
- 5) Remove door mount speaker.

3. REAR SPEAKER (SEDAN)

- 1) Remove rear seat cushion and rear backrest.
- 2) Remove left and right rear quarter trim panels.
- 3) Remove rear shelf trim panel.
- 4) Remove screws which secure speaker.
- 5) Remove speaker while disconnecting connector from speaker.

4. REAR SPEAKER (WAGON)

- 1) Remove door trim panel. <Ref. to 5-2 [W2A2].>
- 2) Disconnect connector from speaker.
- 3) Remove screws which secure the speaker.
- 4) Remove speaker.

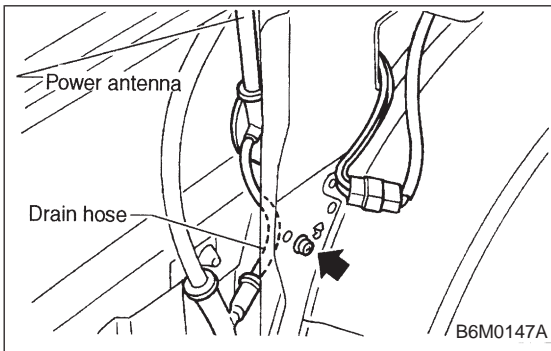

5. POWER ANTENNA

- 1) Remove left side trunk trim (SEDAN), or left side rear lower quarter trim (WAGON).
- 2) Remove special nut (SEDAN).
- 3) Remove bolt which secures power antenna.
- 4) Remove power antenna while disconnecting connector and water drain hose.

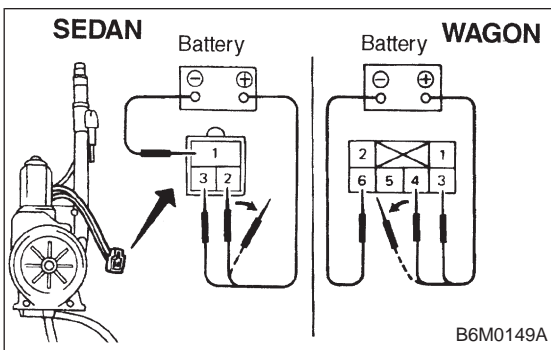

B: INSPECTION

1. POWER ANTENNA

- 1) Connect battery positive (+) terminal to terminal No. 3 and connect terminal No. 1 (SEDAN) or No. 6 (WAGON) to ground. Ensure that antenna rod extends properly when battery positive (+) terminal is connected to terminal No. 2 (SEDAN) or No. 4 (WAGON).
- 2) Ensure that antenna rod retracts properly when battery positive (+) terminal is disconnected from terminal No. 2 (SEDAN) or No. 4 (WAGON).

21. Cruise Control

A: ADJUSTMENT

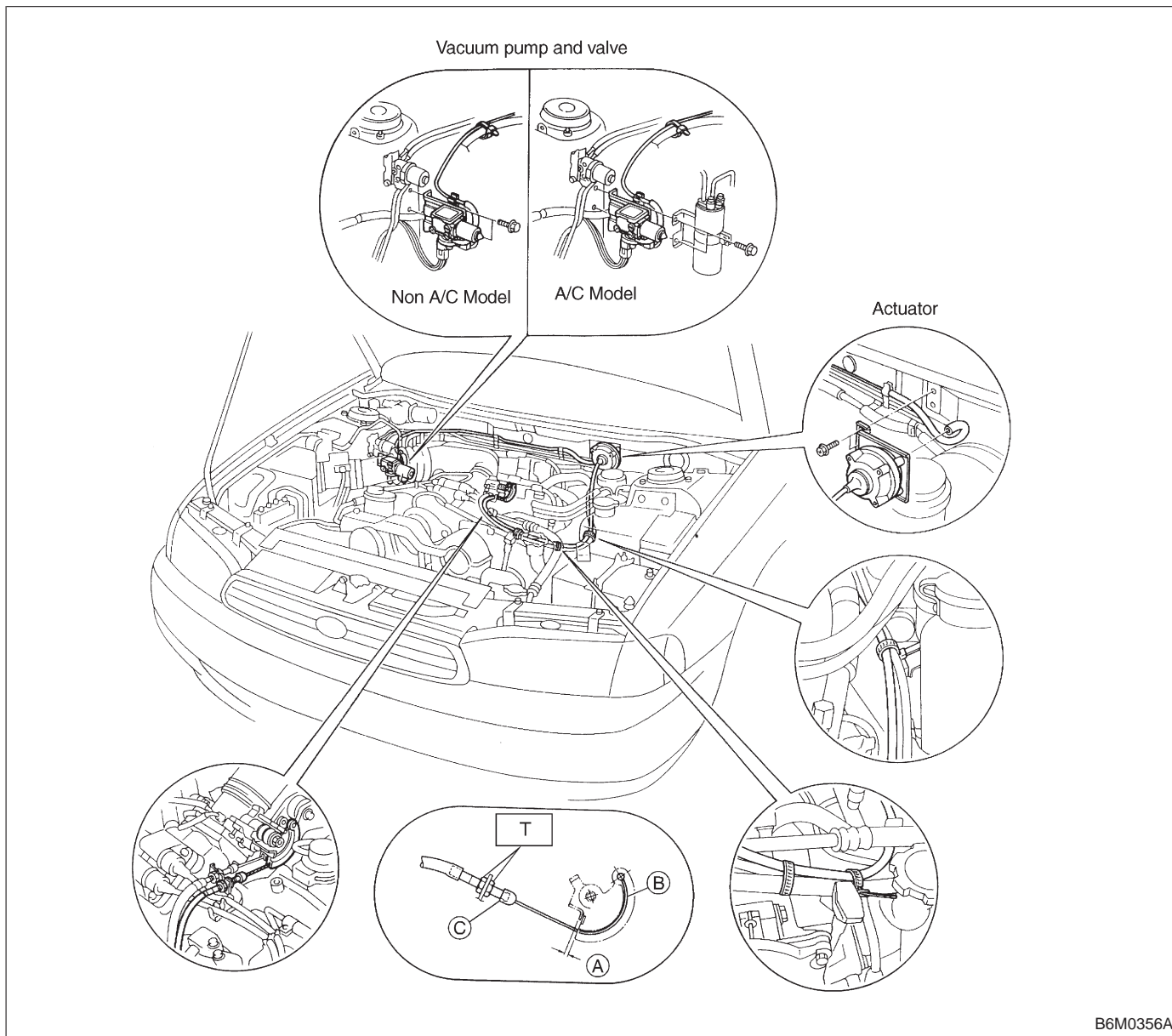
**CAUTION:**

- Ⓐ: Must be adjusted when cable end outer is fixed in place, so that gap between throttle cam and lever is 1.0_{-1}^0 mm ($0.04_{-0.04}^0$ in). (Must be attached while throttle cam is being pulled by wire cable.)
- Ⓑ: Must be coated evenly on cam end inner connection.
- Ⓒ: Cover must be inserted securely, until tip of cable touches cover stopper.

Tightening torque: N·m (kg·m, ft·lb)

T: 6.4 — 11.3 (0.65 — 1.15, 4.7 — 8.3)

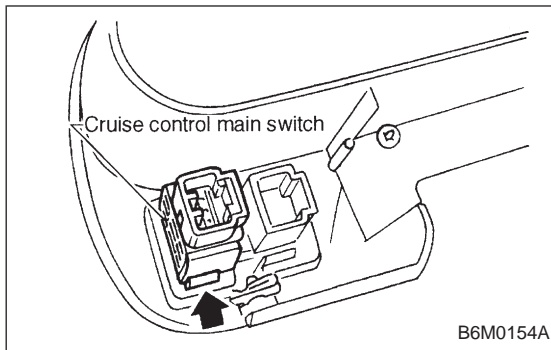

B: REMOVAL AND INSTALLATION

1. CRUISE CONTROL MAIN SWITCH

- 1) Remove screws which secure meter visor.
- 2) Remove meter visor from instrument panel while disconnecting connectors.
- 3) Remove cruise control main switch from meter visor.

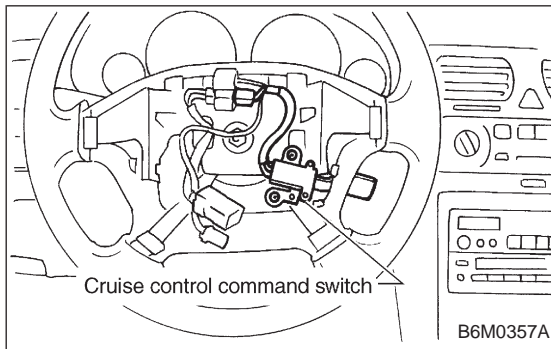

2. CRUISE CONTROL COMMAND SWITCH

- 1) Remove screw which secures horn pad to the base of steering wheel.
- 2) Remove horn pad from steering wheel while disconnecting connector.
- 3) Disconnect connector of cruise control command switch.
- 4) Remove screws which secure cruise control command switch to steering wheel, and then remove command switch.

WARNING:

Refer to 5-5 when removing or installing the module from the airbag equipped model.

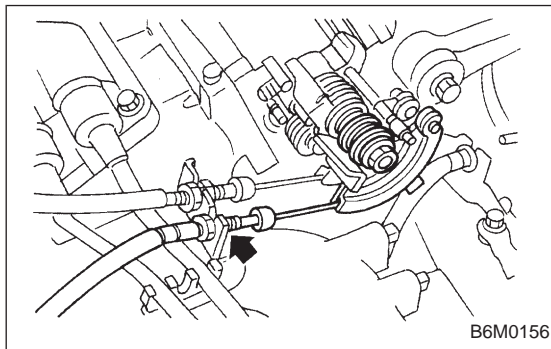

3. ACTUATOR

- 1) Loosen nut which secures cruise control cable end to throttle cam, and then remove cable from engine throttle cam.
- 2) Remove clip bands from cruise control cable.

CAUTION:

- Be careful not to apply excessive load to the wire cable when adjusting and/or installing; otherwise, the actuator may be deformed or damaged.
- Do not bend cable sharply with a radius less than 100 mm (3.94 in); otherwise, cable may bend permanently, resulting in poor performance.
- When installing cable, be careful not to sharply bend or pinch the inner cable; otherwise, the cable may break.

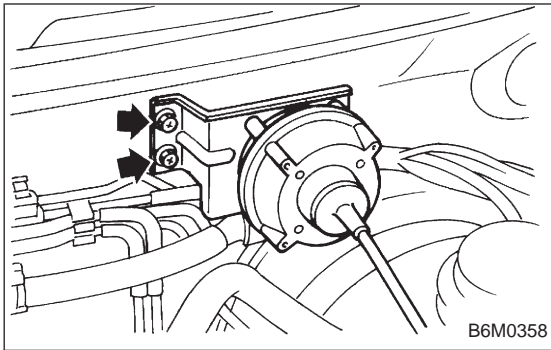

- 3) Remove nuts which secure actuator.
- 4) Remove actuator while disconnecting vacuum hose.

Tightening torque:

$7.4 \pm 1.5 \text{ N}\cdot\text{m}$ ($0.75 \pm 0.15 \text{ kg}\cdot\text{m}$, $5.4 \pm 1.1 \text{ ft}\cdot\text{lb}$)

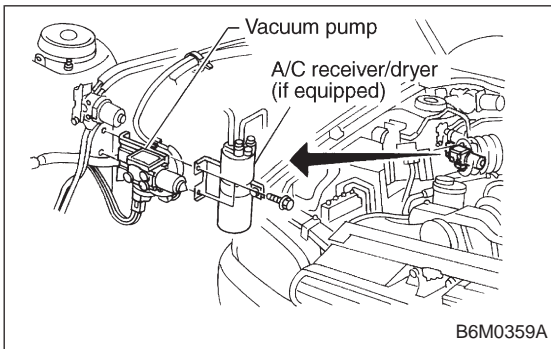
**4. VACUUM PUMP AND VALVES**

- 1) Disconnect connector from vacuum pump.
- 2) Remove bolts which secure vacuum pump.
- 3) Remove A/C receiver/drier bracket.
- 4) Remove vacuum pump while disconnecting vacuum hose.

Tightening torque:

$7.4 \pm 1.5 \text{ N}\cdot\text{m}$ ($0.75 \pm 0.15 \text{ kg}\cdot\text{m}$, $5.4 \pm 1.1 \text{ ft}\cdot\text{lb}$)

5. STOP AND BRAKE SWITCH

Refer to 4-5 [C101] (MT) or 4-5 [C201] (AT) as for removal and installation of stop and brake switch.

6. CLUTCH SWITCH (MT)

Refer to 4-5 [C101] as for removal and installation of clutch switch.

7. INHIBITOR SWITCH (AT)

Refer to 3-2 [W4A3] as for removal and installation of inhibitor switch.

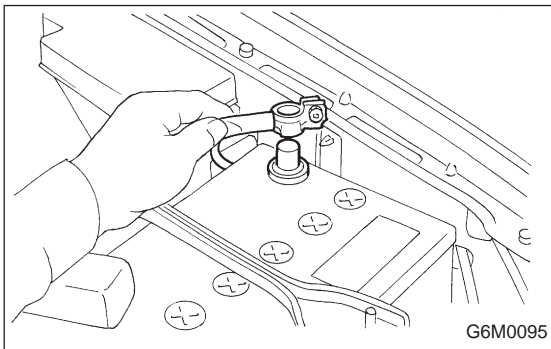
**8. CRUISE CONTROL MODULE**

- 1) Disconnect battery ground cable.

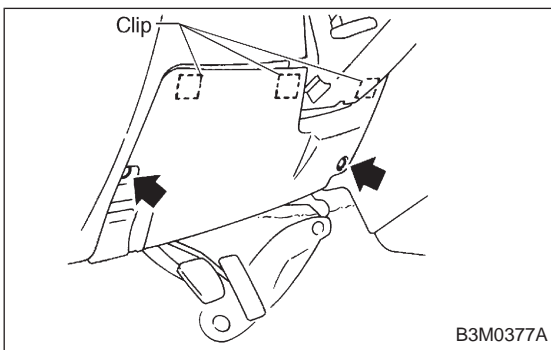

- 2) Remove lower cover and then disconnect connector.

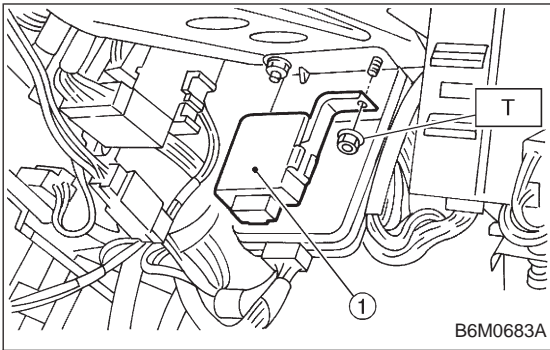

3) Remove door lock timer ① while disconnecting connector.

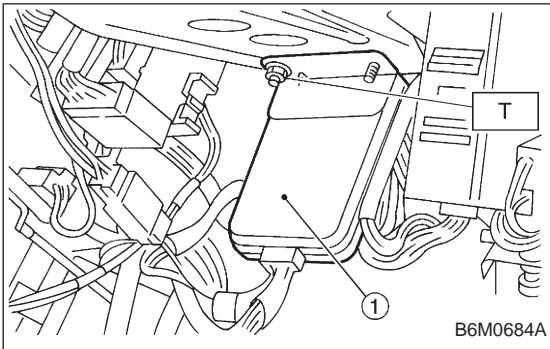

4) Remove cruise control module ① while disconnecting connector.

5) Installation is in the reverse order of removal.

Tightening torque:

7.4 ± 2.5 N·m (0.75 ± 0.25 kg·m, 5.4 ± 1.8 ft·lb)

C: DRIVING TESTS

Conduct road tests by selecting a smooth, flat road or use free rollers as road test simulation.

1. MAIN SWITCH

- 1) Turn ignition switch ON.
- 2) Check that indicator light comes on when main switch is pressed (ON).
- 3) Check that indicator light goes out when main switch is pressed again (OFF).
- 4) Turn ignition switch OFF with main switch ON (which is indicated by illumination.).
- 5) Turn ignition switch ON again to ensure that indicator light remains OFF.

2. COMMAND SWITCH

- 1) Check that command switch is properly set in "SET/COAST", "RESUME/ACCEL" or "CANCEL" mode.
- 2) Also check that command switch returns to the original position when released.

3. CONSTANT SPEED TEST

- 1) Turn main switch ON.
- 2) Drive vehicle at speed greater than 40 km/h (25 MPH).
- 3) Press command switch to set in "SET/COAST" mode.
- 4) Ensure that vehicle is maintained at the speed set when command switch was pressed.

4. ACCELERATION TEST

- 1) Set vehicle speed at speed greater than 40 km/h (25 MPH).
- 2) Ensure that vehicle continues to accelerate while holding command switch in RESUME/ACCEL mode, and that vehicle maintains that optional speed when command switch is released.

5. DECELERATION TEST

- 1) Set vehicle speed at optional speed greater than 40 km/h (25 MPH).
- 2) Ensure that vehicle continues to decelerate while holding command switch in SET/COAST mode, and that it maintains that optional speed when command switch is released.

NOTE:

When vehicle speed reaches the lower speed limit of 30 km/h (19 MPH) during deceleration, cruise control will be released.

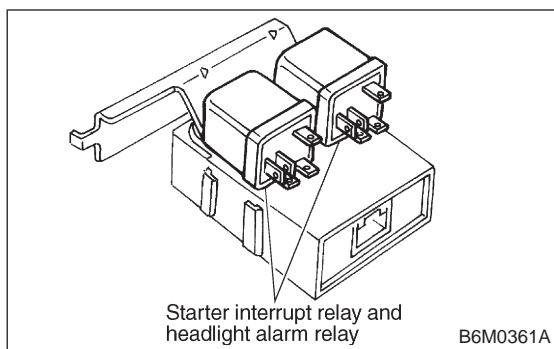

22. Security System

A: REMOVAL AND INSTALLATION

1. STARTER INTERRUPT RELAY

NOTE:

The starter interrupt relay and headlight alarm relay use the same parts and are mounted parallel to each other. Therefore, before removal and installation, identify the starter interrupt relay by the color of its wiring connection. <Ref. to 6-3 [WIRING DIAGRAM SECTION].>

- 1) Remove instrument panel lower cover.
- 2) Disconnect connector of starter interrupt relay.
- 3) Remove starter interrupt relay.
- 4) Installation is in the reverse order of removal.

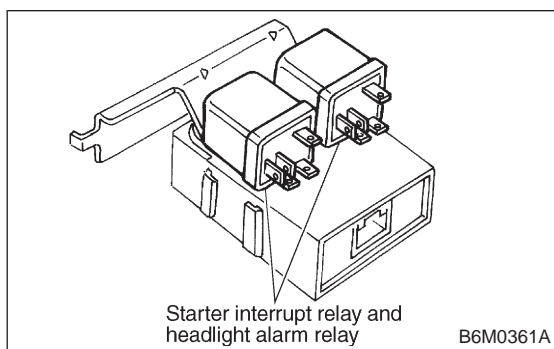

2. HEADLIGHT ALARM RELAY

NOTE:

The headlight alarm relay and starter interrupt relay use the same parts and are mounted parallel to each other. Therefore, before removal and installation, identify the headlight alarm relay by the color of its wiring connection. <Ref. to 6-3 [WIRING DIAGRAM SECTION].>

- 1) Remove instrument panel lower cover.
- 2) Disconnect connector of headlight alarm relay.
- 3) Remove headlight alarm relay.
- 4) Installation is in the reverse order of removal.

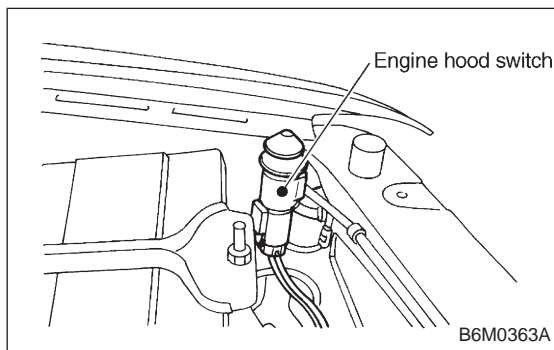

3. ENGINE HOOD SWITCH

- 1) Disconnect connector of engine hood switch from bottom side of switch body.
- 2) Remove headlight (LH).
- 3) Remove attaching bolt, and then remove engine hood switch.
- 4) Installation is in the reverse order of removal.

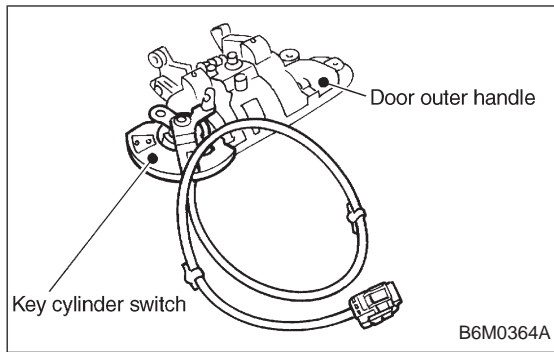

4. KEY CYLINDER LOCK/UNLOCK SWITCH AND TAMPER SWITCH

NOTE:

The key cylinder lock switch, unlock switch and tamper switch are united in the switch body.

Door Switch

- 1) Remove door trim panel and sealing cover. <Ref. to 5-2 [W2A3].>
- 2) Disconnect connector of door key cylinder switch from door cord.
- 3) Remove door outer handle. <Ref. to 5-2 [W2A8].>

CAUTION:

Be careful not to damage the door surface.

- 4) Remove clip, and then remove door key cylinder switch from door outer handle.
- 5) Installation is in the reverse order of removal.

Trunk Lid Switch (SEDAN)

- 1) Disconnect connector of trunk lid key cylinder switch.
- 2) Disconnect rod from key cylinder.
- 3) Remove trunk lid key cylinder switch by pushing it.
- 4) Installation is in the reverse order of removal.

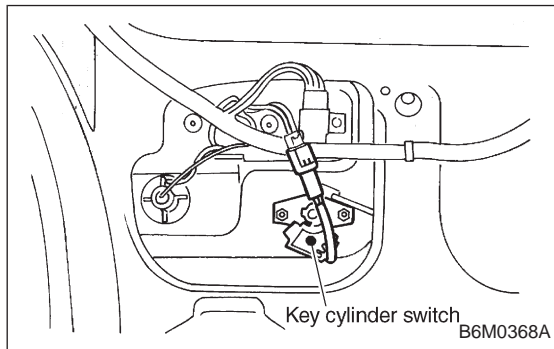

Rear Gate Switch (WAGON)

- 1) Disconnect connector of rear gate key cylinder switch.
- 2) Disconnect rod from key cylinder.
- 3) Remove attaching bolts, and then remove rear gate key cylinder switch.
- 4) Installation is in the reverse order of removal.

5. DOOR LOCK/UNLOCK SWITCH

NOTE:

The door lock/unlock switch is united with the power door lock actuator.

Driver and Passenger Door

- 1) Remove door trim panel and sealing cover. <Ref. to 5-2 [W2A3].>
- 2) Disconnect connector of door lock actuator assembly from door code.

- 3) Remove door lock actuator assembly. <Ref. to 5-2 [W2A7].>
- 4) Installation is in the reverse order of removal.

Rear Gate (WAGON)

- 1) Remove rear gate trim panel.
- 2) Disconnect rod from rear gate latch assembly.
- 3) Disconnect rear gate switch connector and power door lock actuator connector.
- 4) Remove bolts which secure power door lock actuator.
- 5) Remove bolts which secure latch.
- 6) Remove latch and actuator assembly.
- 7) Installation is in the reverse order of removal.

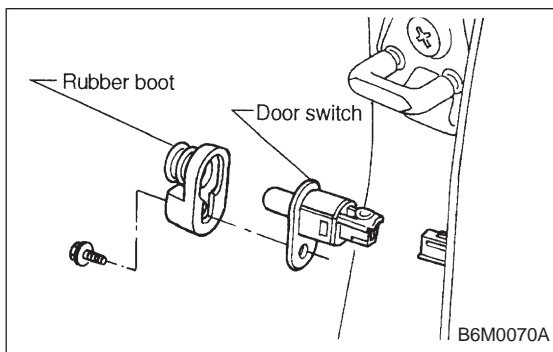

6. DOOR SWITCH

- 1) Remove rubber boot of door switch.
- 2) Remove screw which secures door switch to body.
- 3) Remove door switch while disconnecting connector.

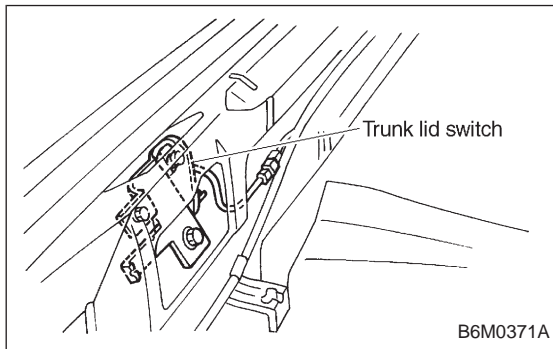

7. TRUNK LID SWITCH (SEDAN)

NOTE:

The trunk lid switch is united with the trunk lid lock.

- 1) Remove trunk rear trim.
- 2) Disconnect connector of trunk switch (combined with trunk room light switch).
- 3) Put matching mark on the trunk lid lock and vehicle body before removal.
- 4) Remove bolts, then remove trunk lid lock from vehicle body.
- 5) Installation is in the reverse order of removal.

NOTE:

Ensure that matching mark is aligned between trunk lid lock and vehicle body.

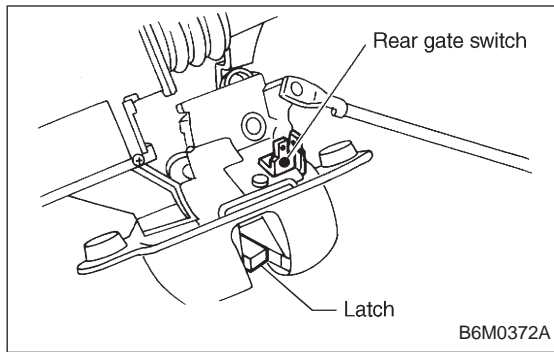

8. REAR GATE SWITCH (WAGON)

NOTE:

The rear gate switch is united with the rear gate latch assembly.

- 1) Remove rear gate trim panel.
- 2) Disconnect rod from rear gate latch assembly.
- 3) Disconnect rear gate switch (combined with luggage room light switch) connector and power door lock actuator connector.
- 4) Remove bolts which secure power door lock actuator.
- 5) Remove bolts which secure latch.
- 6) Remove latch and actuator assembly.
- 7) Installation is in the reverse order of removal.

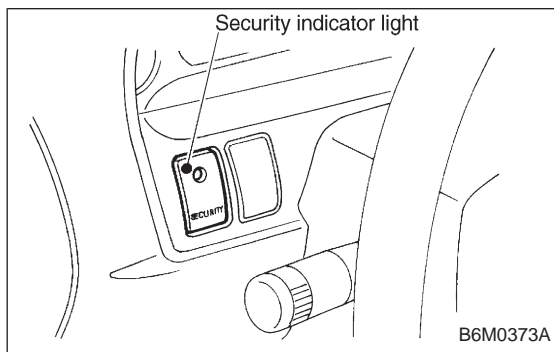

9. SECURITY INDICATOR LIGHT

- 1) Remove screws which secure meter visor.
- 2) Remove meter visor from instrument panel while disconnecting connectors.
- 3) Remove security indicator light from meter visor.
- 4) Installation is in the reverse order of removal.

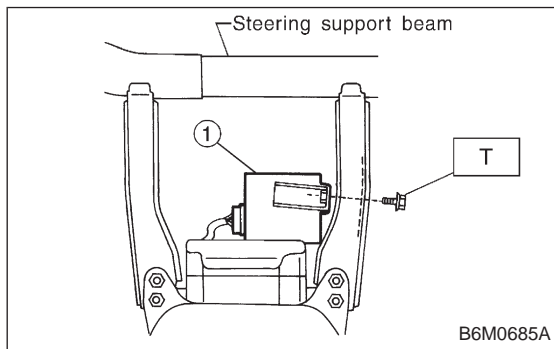

10. SECURITY CONTROL MODULE

- 1) Remove instrument panel. <Ref. to 5-4 [W1A0].>
- 2) Remove bolt which secures security control module ①.
- 3) Remove security control module while disconnecting connector.
- 4) Installation is in the reverse order of removal.

Tightening torque (spark plug):

$7.4 \pm 2.0 \text{ N}\cdot\text{m}$ ($0.75 \pm 0.2 \text{ kg}\cdot\text{m}$, $5.4 \pm 1.4 \text{ ft}\cdot\text{lb}$)

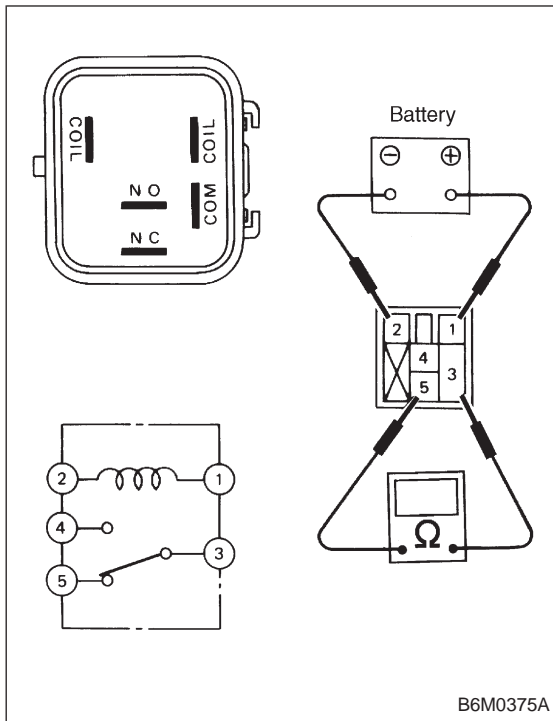

B: INSPECTION

1. STARTER INTERRUPT RELAY

- 1) Disconnect connector of starter interrupt relay.
- 2) Connect battery to terminal No.1 and ground terminal No. 2.
- 3) Check continuity between terminals as indicated in table below:

When current flows.	Between terminals No. 3 and No. 5	Continuity does not exist.
When current does not flow.	Between terminals No. 3 and No. 5	Continuity exists.
	Between terminals No. 1 and No. 2	Continuity exists.

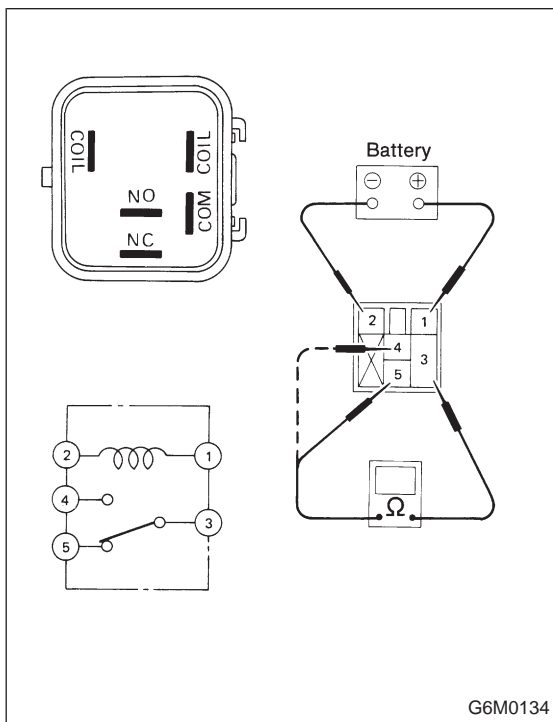

2. HEADLIGHT ALARM RELAY

- 1) Disconnect connector of headlight alarm relay.
- 2) Connect battery to terminal No. 1 and ground terminal No. 2.
- 3) Check continuity between terminals as indicated in table below:

When current flows.	Between terminals No. 3 and No. 5	Continuity does not exist.
	Between terminals No. 3 and No. 4	Continuity exists.
When current does not flow.	Between terminals No. 3 and No. 5	Continuity exists.
	Between terminals No. 3 and No. 4	Continuity does not exist.
	Between terminals No. 1 and No. 2	Continuity exists.

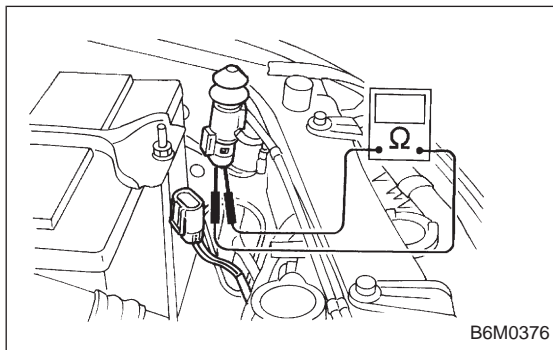

3. ENGINE HOOD SWITCH

- 1) Disconnect connector of engine hood switch.
- 2) Check continuity between terminals when push rod is pushed in 1.5 mm (0.059 in) of its stroke.

Terminal	1	2
Switch position		
When push rod is pushed in.		
When push rod is released.	○	○

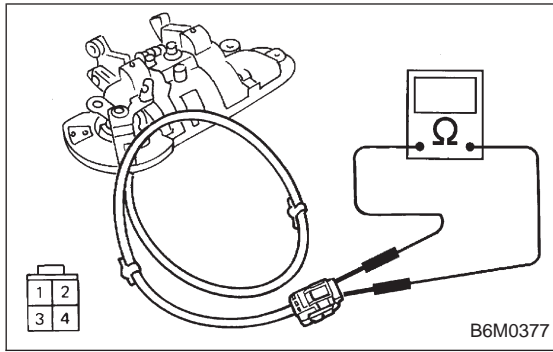

4. KEY CYLINDER LOCK/UNLOCK SWITCH AND TAMPER SWITCH

Door Switch

- 1) Disconnect connector of door key cylinder switch.
- 2) Move switch by turning the key cylinder with ignition key and/or remove switch from key cylinder to check continuity between terminals as indicated in table below:

Terminal	1	2	3	4
Switch position				
Normal				
LOCK	○	—	—	○
UNLOCK		○	—	○
Switch is removed from key cylinder.			○	○

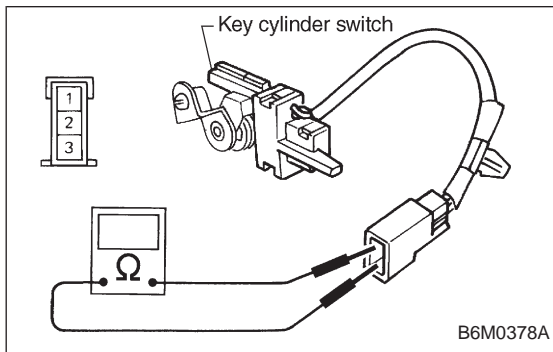

Trunk Lid Switch (SEDAN)

- 1) Disconnect connector of trunk lid key cylinder switch.
- 2) Move switch by turning the key cylinder with ignition key and/or remove switch from key cylinder to check continuity between terminals as indicated in table below:

Terminal	1	2	3
Switch position			
Normal			
UNLOCK	○	—	○
Switch is removed from key cylinder.		○	○

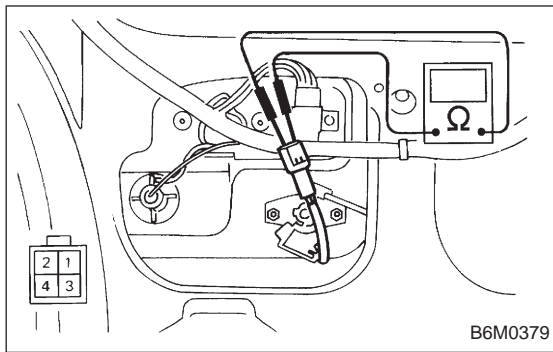

Rear Gate Switch (WAGON)

- 1) Disconnect connector of rear gate key cylinder switch.
- 2) Move switch by turning the key cylinder with ignition key and check continuity between terminals as indicated in table below:

Terminal	1	2	4
Switch position			
Normal			
LOCK	○	—————	○
UNLOCK		○	○

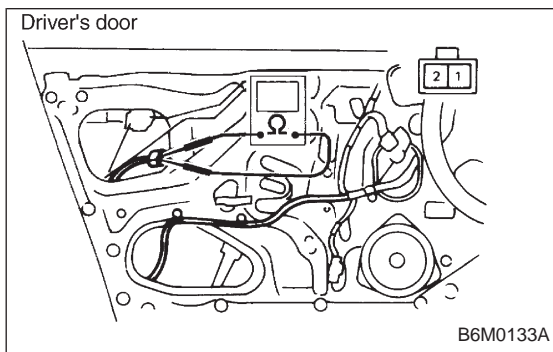

5. DOOR LOCK/UNLOCK SWITCH

NOTE:

The door lock/unlock switch is united with the power door lock actuator.

- 1) Disconnect connector of door lock/unlock switch.
- 2) Set switch to each position and check continuity between terminals as indicated in table below:

Driver's Door

Terminal	1	2
Switch position		
UNLOCK	○	○
LOCK		

Passenger's Door

Terminal	1	2	3	4
Switch position				
UNLOCK	○	—————	○	
LOCK				

Rear Gate (WAGON)

Terminal	1	2	3	4
Switch position				
UNLOCK	○	—————	○	
LOCK				

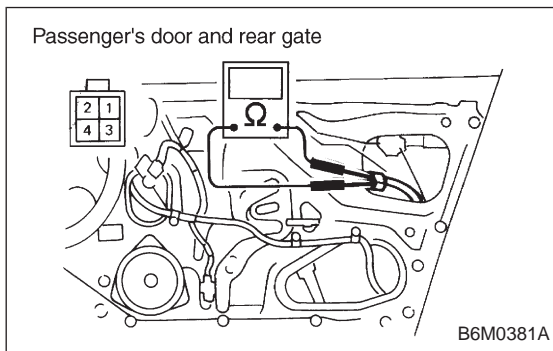

6. DOOR SWITCH

Refer to 6-2 [W8B1] as for inspection of door switch.

NOTE:

The door switch is combined with the door switch for room light.

7. TRUNK LID SWITCH (SEDAN)

Refer to 6-2 [W8B2] as for inspection of trunk lid switch.

NOTE:

The trunk lid switch is combined with the trunk room light switch.

8. REAR GATE SWITCH (WAGON)

Refer to 6-2 [W8B3] as for inspection of rear gate switch.

NOTE:

The rear gate switch is combined with the luggage room light switch.

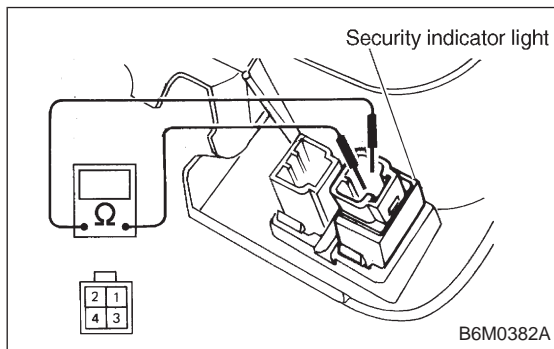
**9. SECURITY INDICATOR LIGHT**

- 1) Remove security indicator light.
- 2) Check continuity between terminals of security indicator light.
- 3) If there is no continuity, the indicator light will be failed.

Terminals: No. 2 — No. 4

10. SECURITY CONTROL MODULE

Refer to 6-2 [K600]: "6. SECURITY SYSTEM" for inspection of security control module.

C: FUNCTION TEST**1. SECURITY SYSTEM OPERATION**

- 1) Fully open all the door windows.
- 2) Turn the ignition switch to OFF and remove ignition key from ignition switch.
- 3) Get out of the vehicle and lock the driver's door using a ignition key.

- 4) Check that the security indicator light illuminates.
- 5) When the security indicator light illuminates, wait for 30 seconds.

After 30 seconds, check that the light starts repeating 0.2 sec. ON and 2.4 sec. OFF sequence.

- 6) Unlock the driver's door using the inside lock knob and open the door.

Ensure that:

- (1) the horn sounds and headlights flash intermittently at 0.2 sec. ON and 0.6 sec. OFF. intervals, and
- (2) the engine will not start even if the ignition switch is turned to START.

- 7) Unlock the driver's door one time using the ignition key. Ensure the horn and headlights turn off.

- 8) Close and lock the driver's door without using a ignition key. (Set the inside lock knob to LOCK and then close the door while lifting the outer handle).

Check that the security indicator light illuminates continuously.

- 9) Within 30 seconds after the above step 8), unlock the rear LH door using the inside lock knob and open the door. Check that the security indicator light flashes at 0.5 sec. intervals.

- 10) Close the rear LH door and lock the door using the inside lock knob.

Check that the security indicator light illuminates continuously.

- 11) Perform the above steps 9) and 10) on the rear RH door and front RH door.

- 12) Within 30 seconds after above step 11) has been finished, pull the engine hood opener lever and open the engine hood.

Check that the security indicator light flashes at 0.5 sec. intervals.

- 13) Close the engine hood completely.

Check that the security indicator light illuminates continuously.

14) Within 30 seconds after the above step 13), pull the trunk lid opener lever and open the trunk lid (SEDAN); or unlock the rear gate by operating the driver's door inside lock knob and open the rear gate (WAGON).

Check that the security indicator light flashes at 0.5 sec. intervals.

15) Close the trunk lid completely (SEDAN); or close the rear gate and lock by locking the driver's door using a ignition key (WAGON).

Check that the security indicator light illuminates continuously.

16) When the security indicator light illuminates continuously, wait for 30 seconds.

After 30 seconds, check that the light starts repeating 0.2 sec. ON and 2.4 sec. OFF sequence.

17) Unlock the trunk lid (SEDAN) or rear gate (WAGON) using a ignition key and open.

Check that the horn and headlights do not operate.

18) Close the trunk lid (SEDAN) or rear gate (WAGON).

19) Unlock and then lock the driver's door using a ignition key and wait for 30 seconds.

After 30 seconds, check that the light starts repeating 0.2 sec. ON and 2.4 sec. OFF sequence.

20) Only WAGON model; unlock and then lock the rear gate using a ignition key and wait for 30 seconds.

After 30 seconds, check that the light starts repeating 0.2 sec. ON and 2.4 sec. OFF sequence.

21) Unlock the front RH door using a ignition key and open the door.

Check that the horn and headlights do not operate.

After finishing the above checks, ensure that security system's function is correct.

23. Seat Heater

A: REMOVAL AND INSTALLATION

1. SEAT HEATER

Refer to 5-3 [W1A0] as for removal of seat (including heater system).

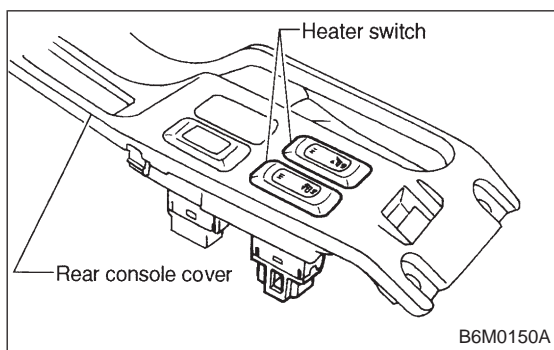

2. SEAT HEATER SWITCH

- 1) Remove screws which secure rear console cover, and then remove rear console cover.
- 2) Remove seat heater switch from console cover.

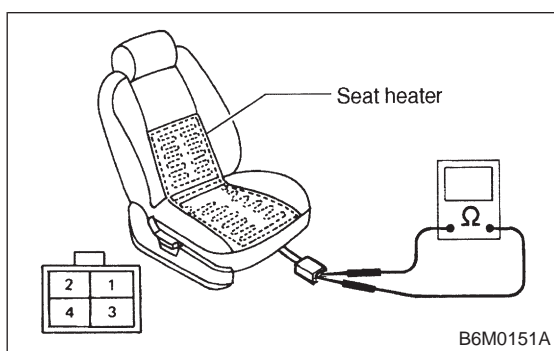

B: INSPECTION

1. SEAT HEATER

Check continuity between terminals of seat heater connector.

- Between terminals No. 1 and No. 3
- Between terminals No. 1 and No. 4
- Between terminals No. 3 and No. 4

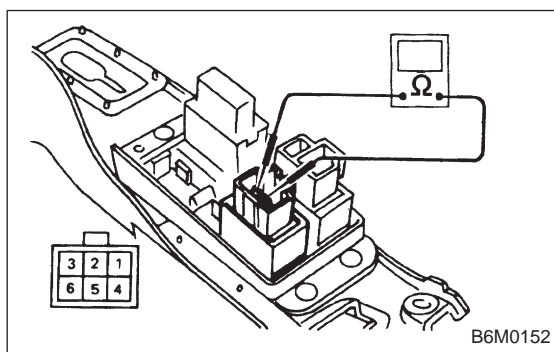

2. SEAT HEATER SWITCH

Set switch to each position and check continuity between terminals as indicated in table below:

Switch	Terminal	5	6	2		3	4		1
OFF					○	○	○	○	○
LO		○	○		○	○	○	○	○
HI		○	○	○	○	○	○	○	○

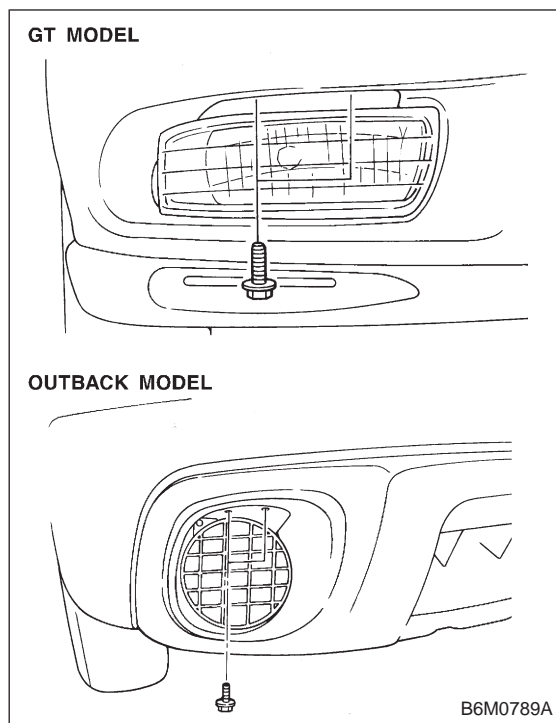

24. Front Fog Light

A: REMOVAL AND INSTALLATION

- 1) Disconnect ground cable from battery.
- 2) Remove the two bolts, then draw out the front fog light from front bumper.
- 3) Disconnect the connector.
- 4) Installation is in the reverse order of removal.

1. Starter Interlock System (MT Model)

A: DIAGNOSTICS PROCEDURE

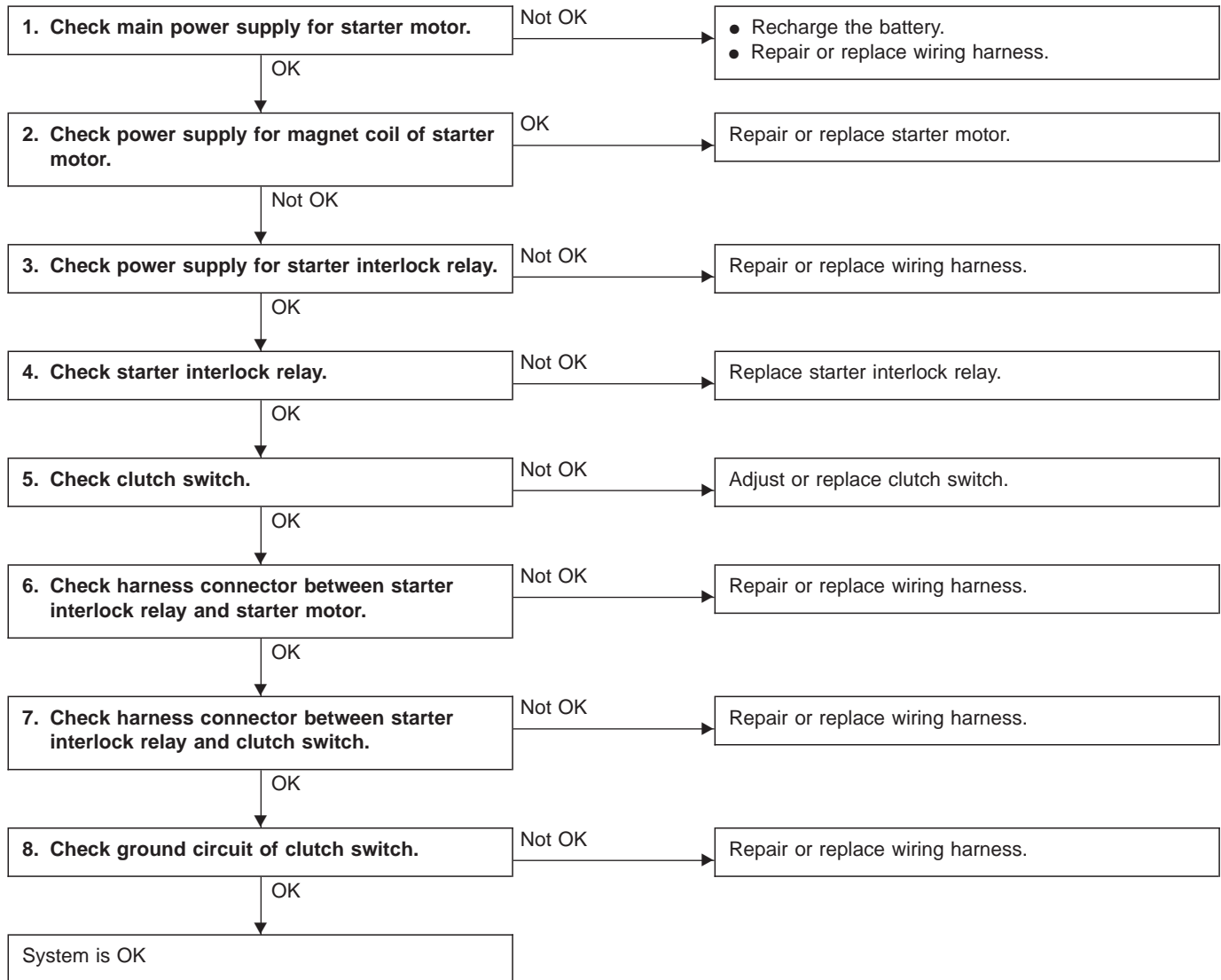

1. Starter Interlock System (MT Model)

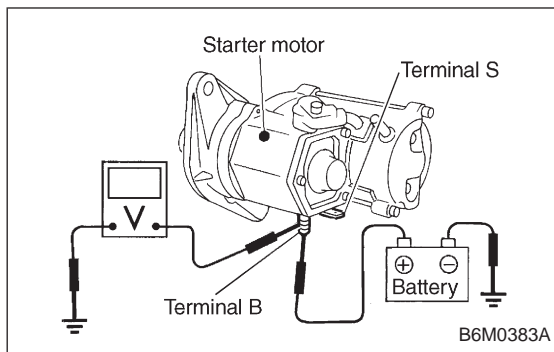

1. CHECK MAIN POWER SUPPLY FOR STARTER MOTOR.

Measure voltage between starter motor terminal B and body.

Connector & terminal / Specified voltage:
Terminal B — Body / 10 V, or more

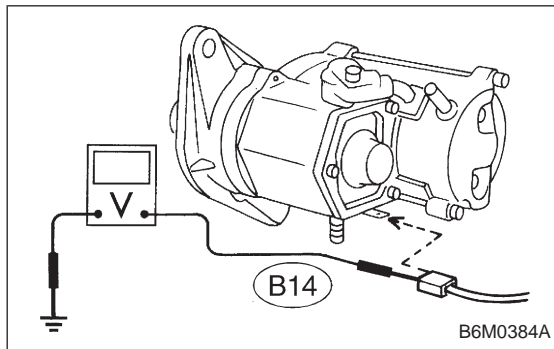

2. CHECK POWER SUPPLY FOR MAGNET COIL OF STARTER MOTOR.

- 1) Disconnect all connectors from starter motor.
- 2) Turn ignition switch to ST (START).
- 3) Depress clutch pedal.
- 4) Measure voltage between starter motor terminal S connector and body.

Connector & terminal / Specified voltage:
(B14) Terminal S — Body / 10 V, or more

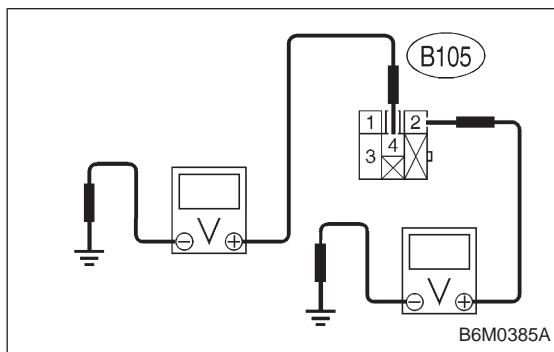

3. CHECK POWER SUPPLY FOR STARTER INTERLOCK RELAY.

- 1) Disconnect all connectors from starter motor.
- 2) Disconnect connector of starter interlock relay.
- 3) Turn ignition switch to ST (START).
- 4) Measure voltage between starter interlock relay connector and body.

Connector & terminal / Specified voltage:
(B105) No. 2 — Body / 10 V, or more
(B105) No. 4 — Body / 10 V, or more

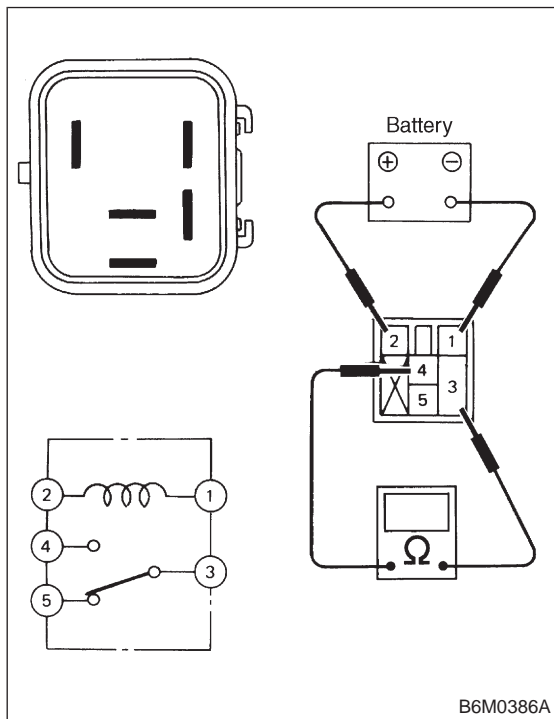

4. CHECK STARTER INTERLOCK RELAY.

- 1) Disconnect connector of starter interlock relay.
- 2) Connect battery to terminal No. 2 and ground terminal No. 1.
- 3) Check continuity between terminals as indicated in table below:

When current flows.	Between terminals No. 3 and No. 4	Continuity exists.
When current does not flow.	Between terminals No. 3 and No. 4	Continuity does not exist.
	Between terminals No. 1 and No. 2	Continuity exists.

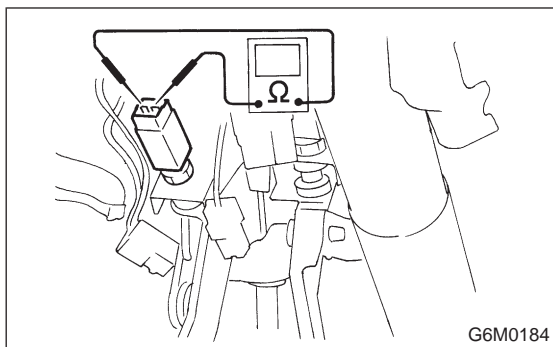
**5. CHECK CLUTCH SWITCH.**

- 1) Disconnect connector of clutch switch.
- 2) Check continuity between terminals when clutch pedal is depressed/released.

Terminals / Specified resistance:

No. 1 — No. 2 / 10 Ω , max.

**(Without pedal depressing.)
/ 1 M Ω , min. (Pedal depressing.)**

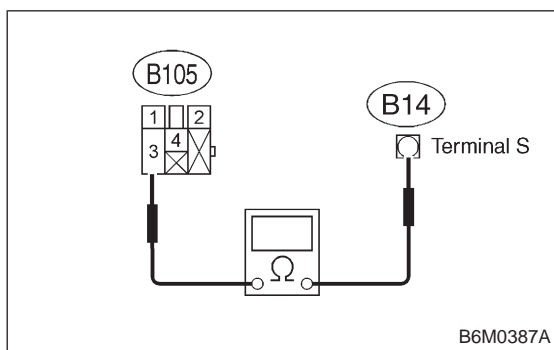
**6. CHECK HARNESS CONNECTOR BETWEEN STARTER INTERLOCK RELAY AND STARTER MOTOR.**

- 1) Disconnect connectors of starter interlock relay and starter motor.
- 2) Measure resistance of harness connector between starter interlock relay and starter motor.

Connector & terminal / Specified resistance:

(B105) No. 3 — (B14) terminal S / 10 Ω , max.

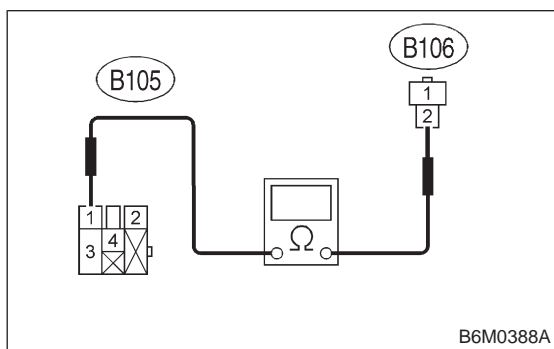
**7. CHECK HARNESS CONNECTOR BETWEEN STARTER INTERLOCK RELAY AND CLUTCH SWITCH.**

- 1) Disconnect connectors of starter interlock relay and clutch switch.
- 2) Measure resistance of harness connector between starter interlock relay and clutch switch.

Connector & terminal / Specified resistance:

(B105) No. 1 — (B106) No. 2 / 10 Ω , max.

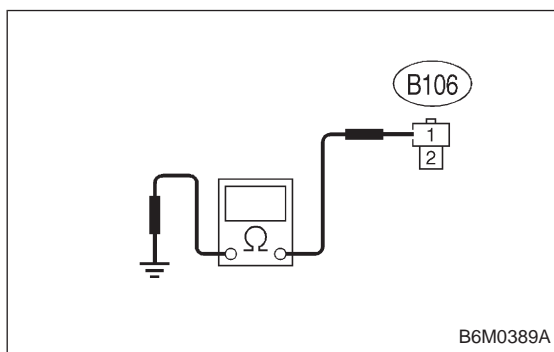
**8. CHECK GROUND CIRCUIT OF CLUTCH SWITCH.**

- 1) Disconnect connector of clutch switch.
- 2) Measure resistance of harness connector between clutch switch and body.

Connector & terminal / Specified resistance:

(B106) No. 1 — Body / 10 Ω , max.

2. AT Shift Lock System

A: WIRING DIAGRAM

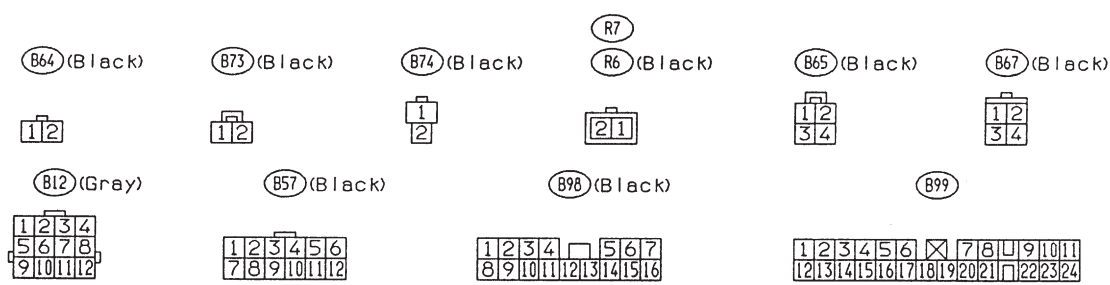
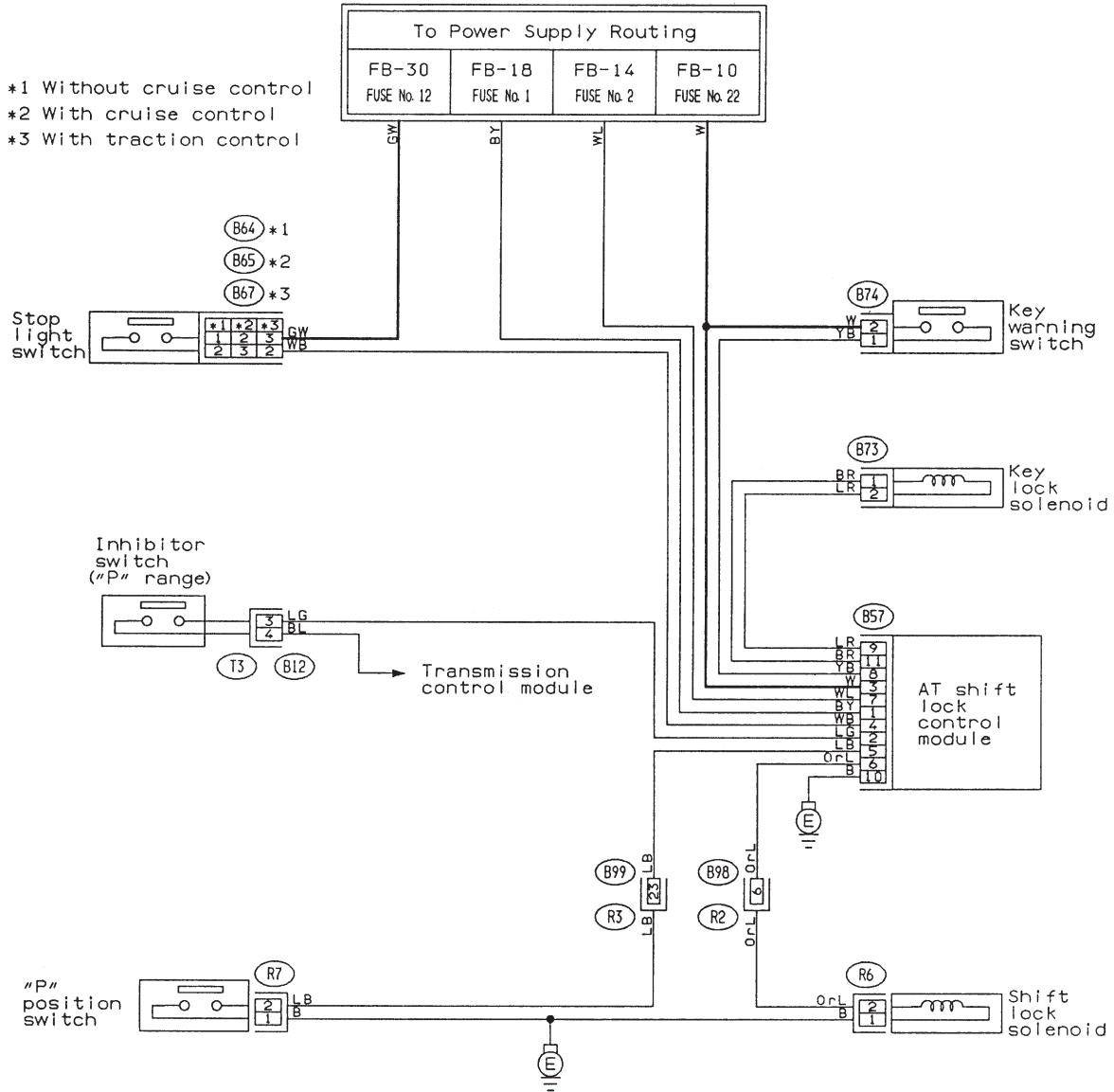

B6M0466

B: BASIC DIAGNOSTICS CHART

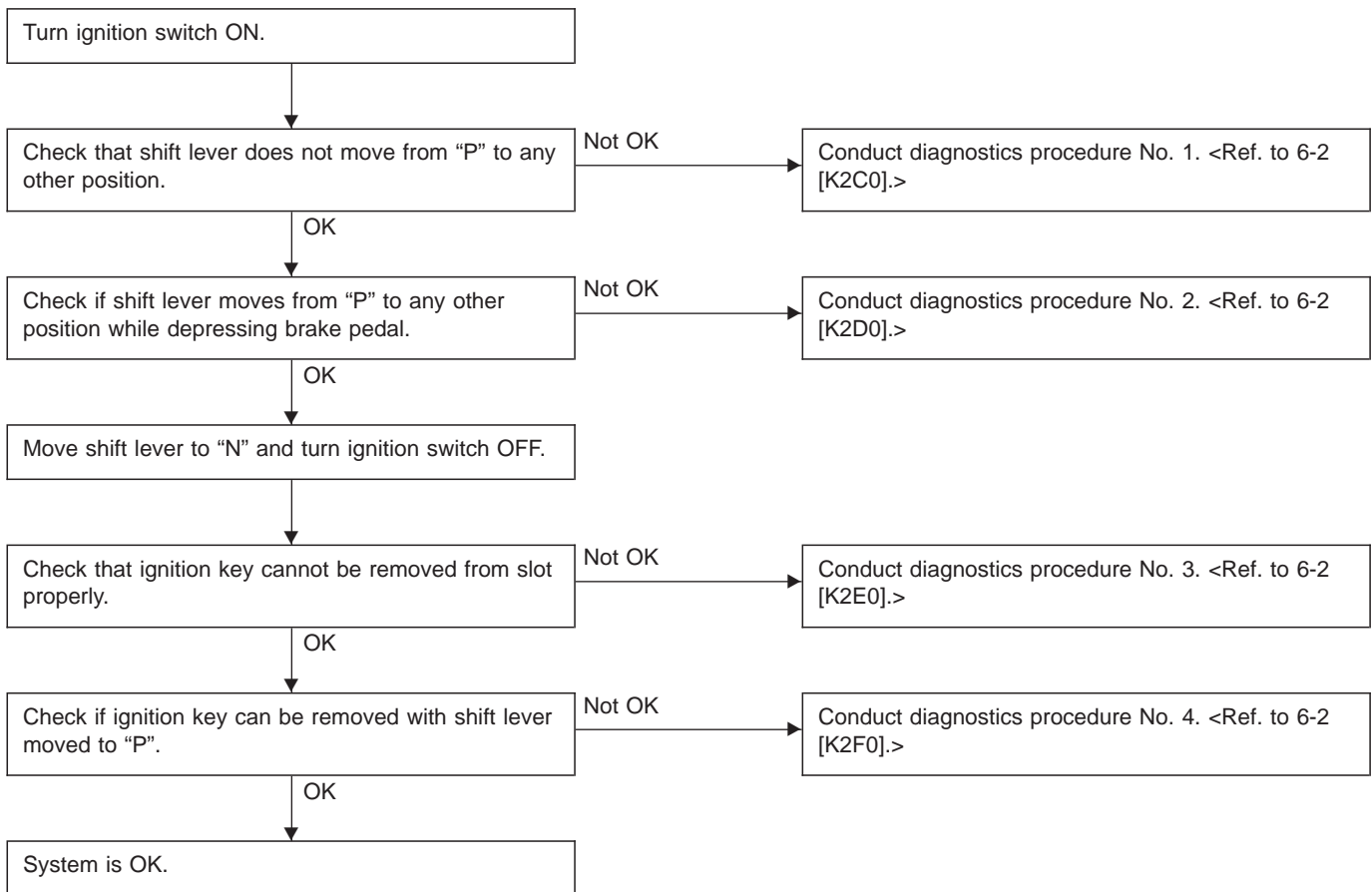

C: DIAGNOSTICS PROCEDURE No. 1

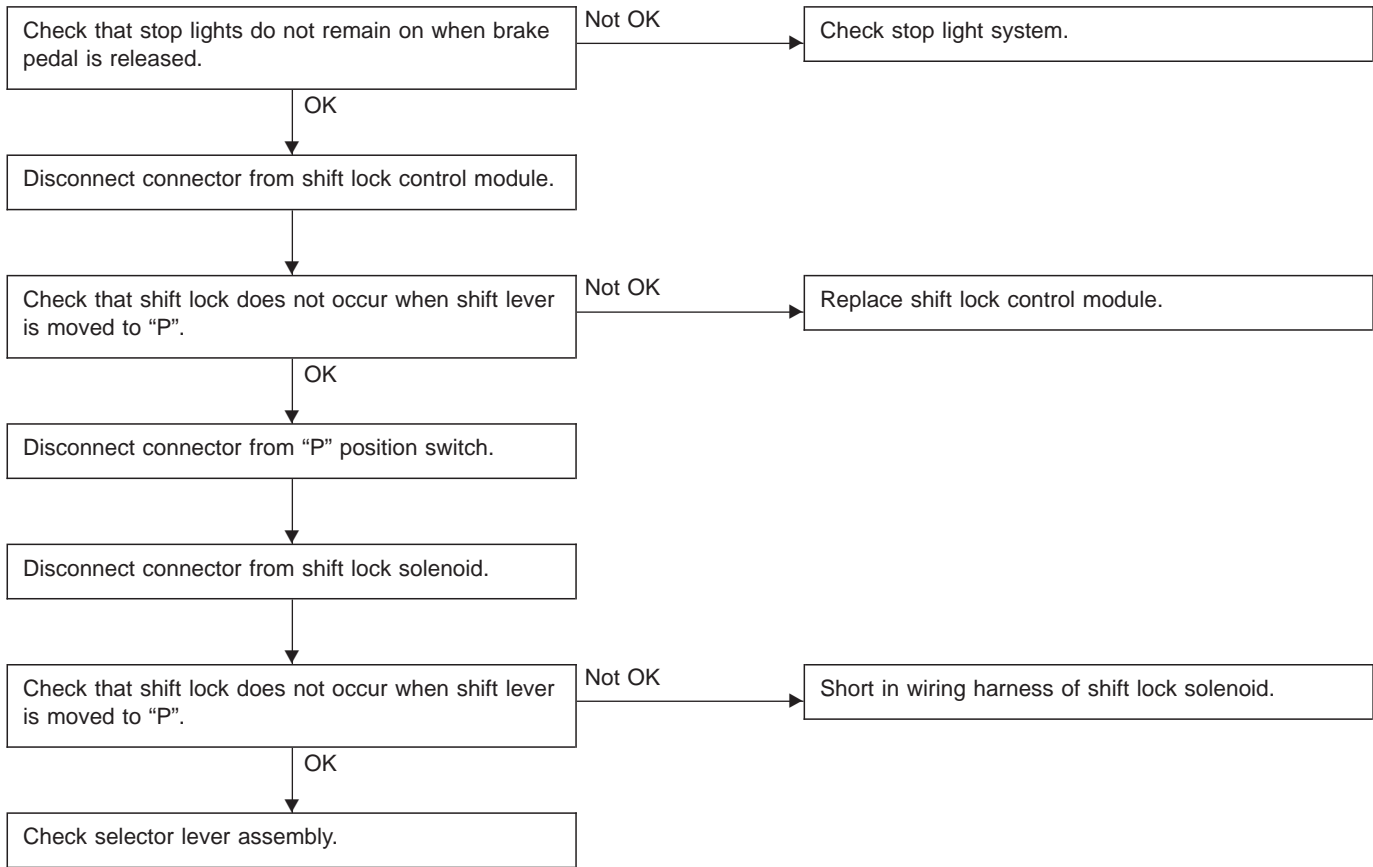

D: DIAGNOSTICS PROCEDURE No. 2 (SHIFT LOCK DOES NOT RELEASE.)

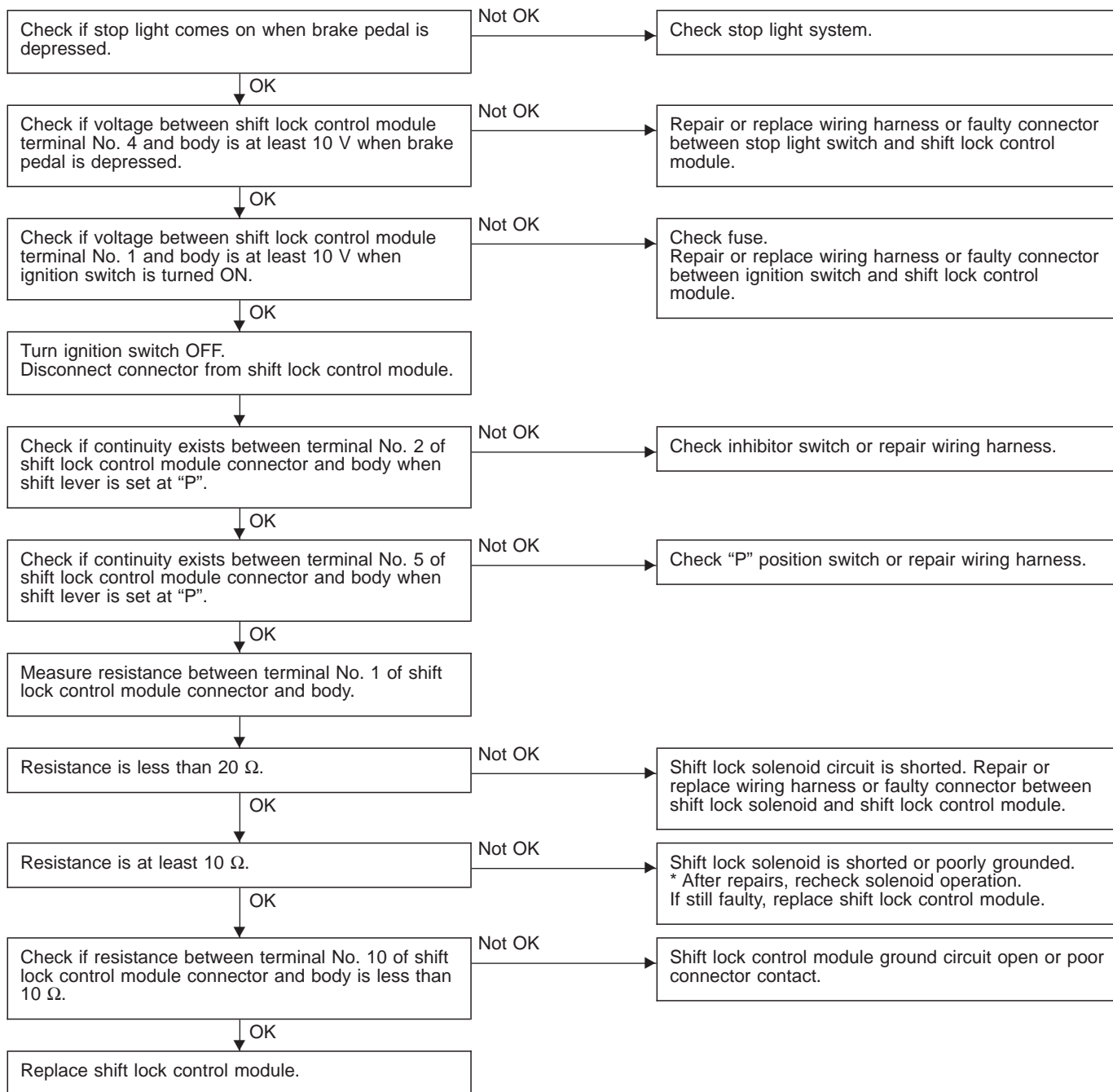

E: DIAGNOSTICS PROCEDURE No. 3 (KEY INTERLOCK DOES NOT OPERATE.)

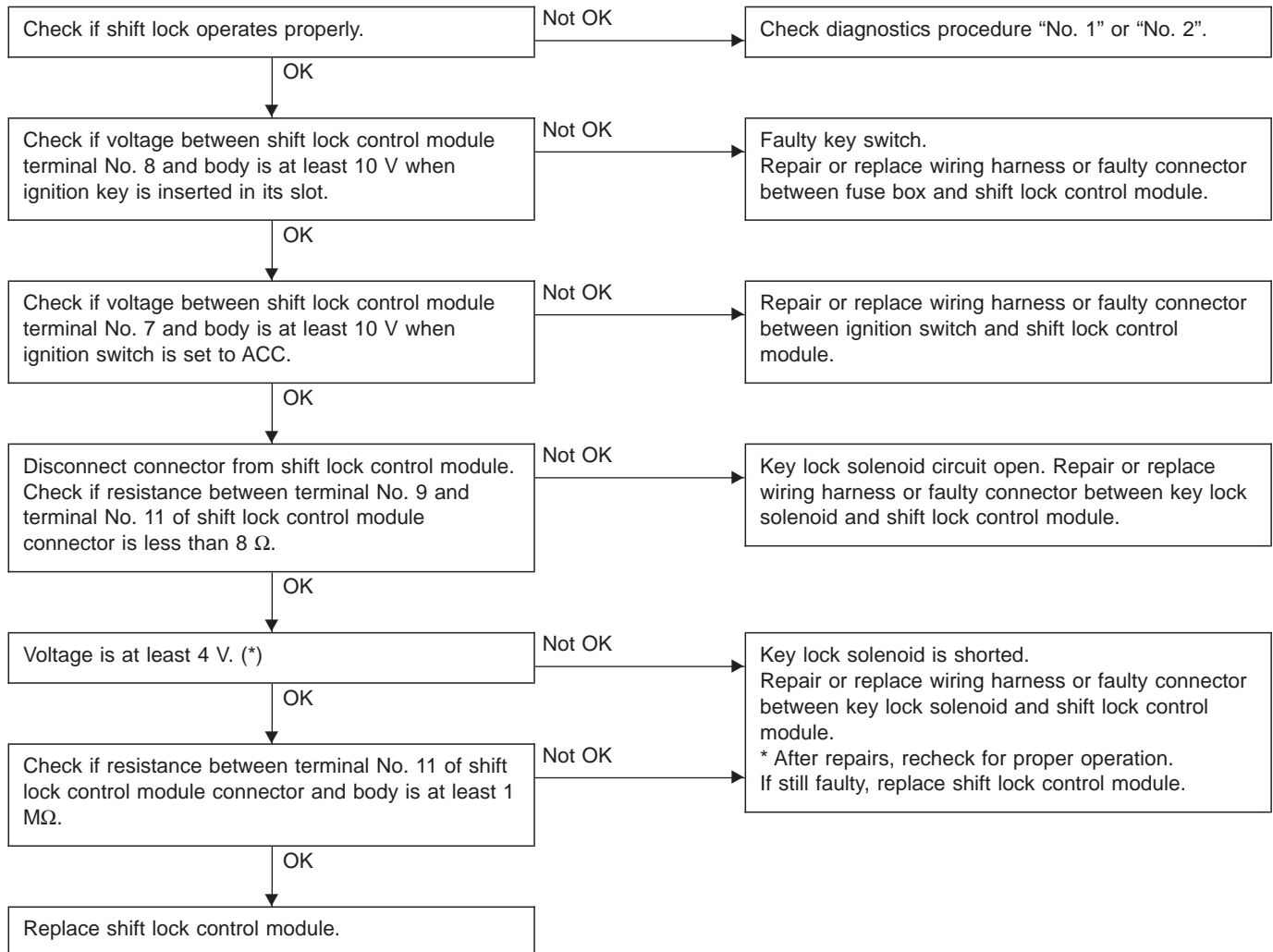

*: When conducting operational checks of the key lock solenoid, do not apply 12 V to solenoid for more than one second, since this may break solenoid circuit.

F: DIAGNOSTICS PROCEDURE No. 4 (KEY INTERLOCK DOES NOT RELEASE.)

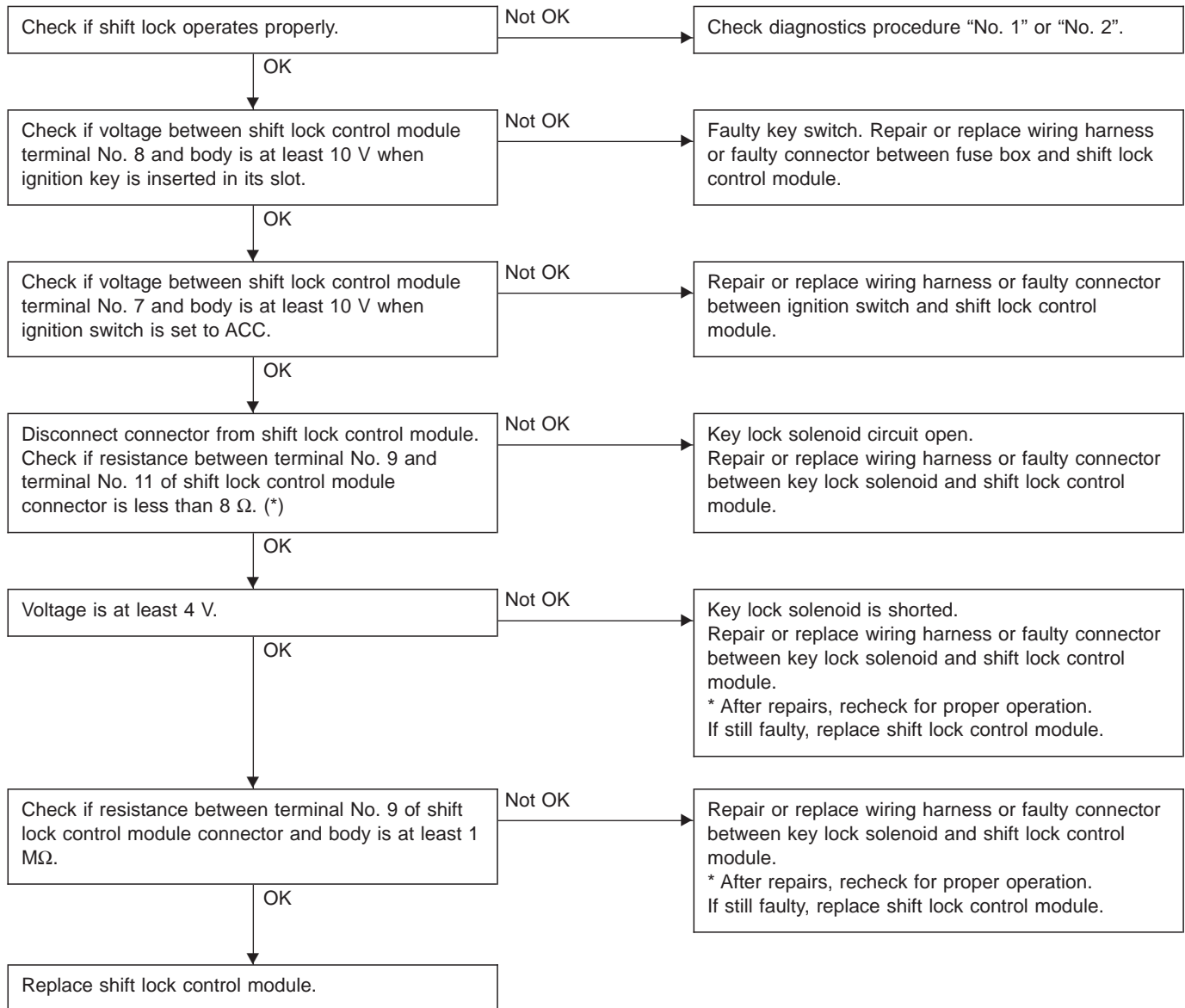

*: When conducting operational checks of the key lock solenoid, do not apply 12 V to solenoid for more than one second, since this may break solenoid circuit.

3. Combination Meter

A: DIAGNOSTICS PROCEDURE

If speedometer does not operate, or operates abnormally, check combination meter circuit (shown in flow chart as described below).

CAUTION:

Make sure that trouble code of vehicle speed sensor 2 system appears in electrical system on-board diagnosis.

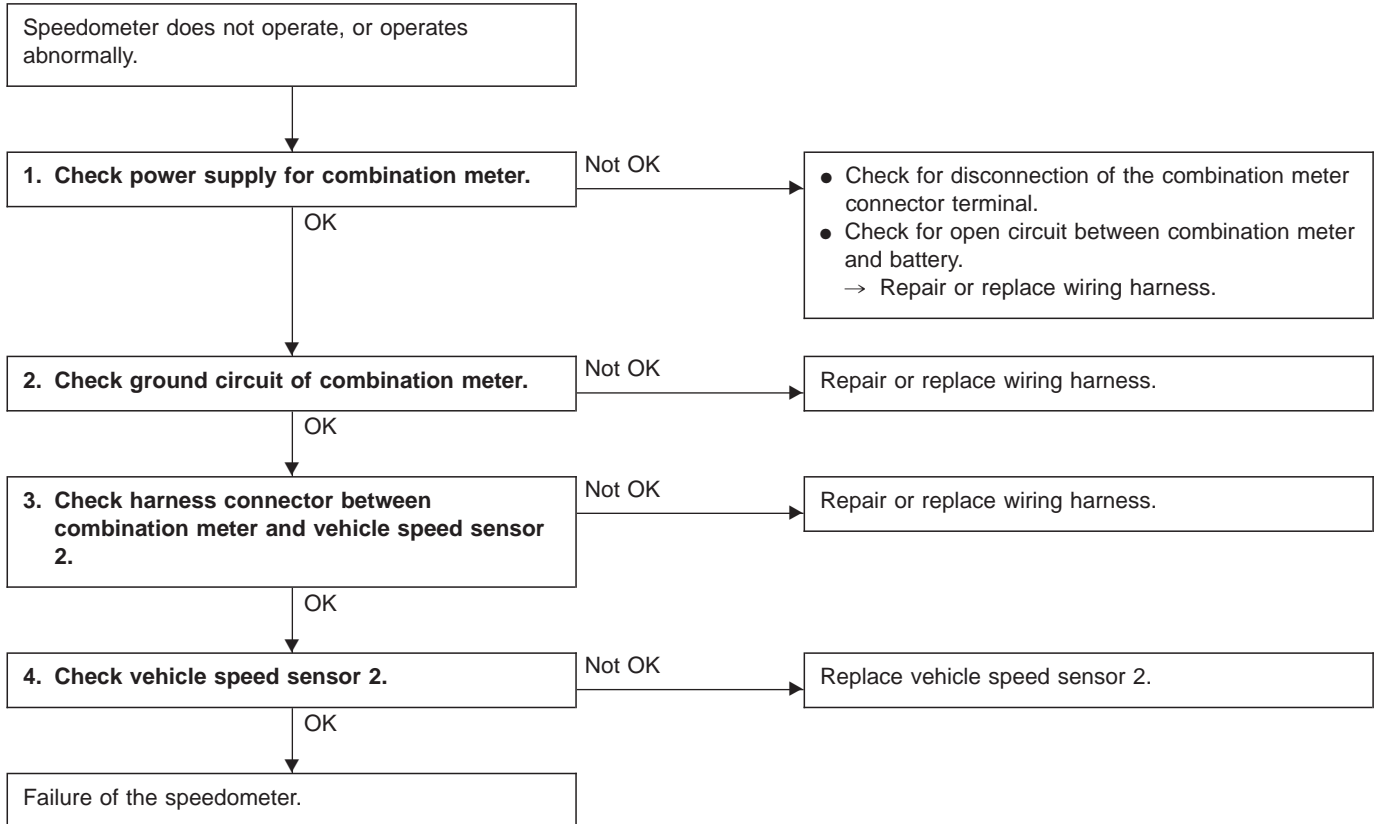

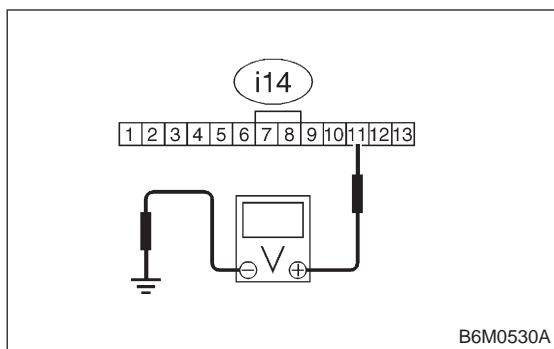

1. CHECK POWER SUPPLY FOR COMBINATION METER.

- 1) Remove combination meter.
- 2) Turn ignition switch to ON.
- 3) Measure voltage at combination meter connector terminal.

Connector & terminal / Specified voltage:
(i14) No. 11 — Body / 10 V, or more

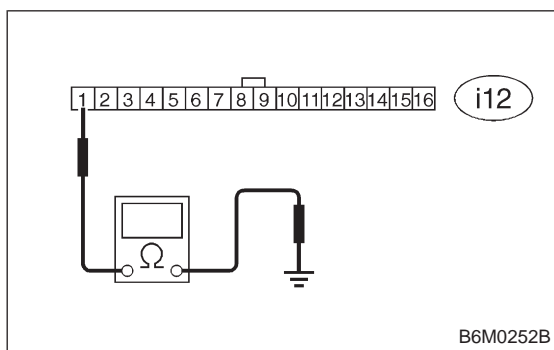

2. CHECK GROUND CIRCUIT OF COMBINATION METER.

- 1) Turn ignition switch to OFF.
- 2) Measure resistance of harness connector between combination meter and body.

Connector & terminal / Specified voltage:
(i12) No. 1 — Body / 10 Ω, max.

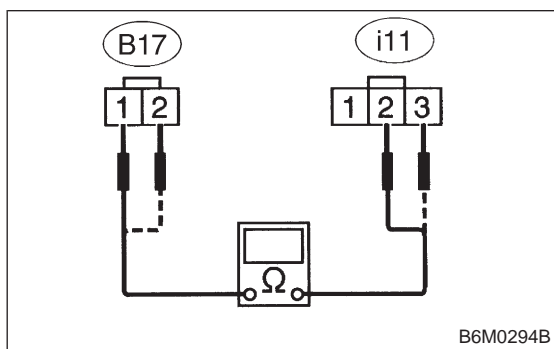

3. CHECK HARNESS CONNECTOR BETWEEN COMBINATION METER AND VEHICLE SPEED SENSOR 2.

- 1) Disconnect connector from vehicle speed sensor 2.
- 2) Measure resistance of harness connector between vehicle speed sensor 2 and combination meter.

Connector & terminal / Specified resistance:
(B17) No. 1 — (i11) No. 2 / 10 Ω, max.
(B17) No. 2 — (i11) No. 3 / 10 Ω, max.

4. CHECK VEHICLE SPEED SENSOR 2.

NOTE:

- If resistance between terminals of vehicle speed sensor 2 is out of specification, the sensor may have a failure.
- If resistance is OK and voltage between terminals of vehicle speed sensor 2 is out of specification, mechanical trouble may be present between vehicle speed sensor 2 and speedometer shaft in transmission.

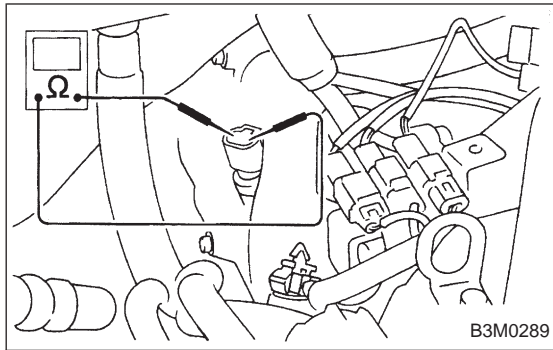

- 1) Disconnect connector from vehicle speed sensor 2.
- 2) Measure resistance between terminals of vehicle speed sensor 2.

Terminals / Specified resistance:

No. 1 — No. 2 / 350 — 450 Ω

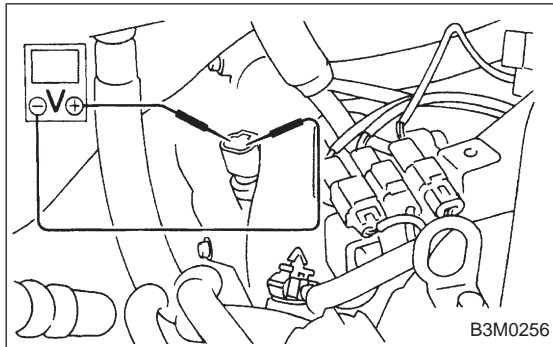

WARNING:

Be careful not to be caught up by the running wheels.

- 3) Set the vehicle on free roller, or lift-up the vehicle and support with safety stands.
- 4) Drive the vehicle at speed greater than 20 km/h (12 MPH).
- 5) Measure voltage between terminals of vehicle speed sensor 2.

Terminals / Specified voltage:

No. 1 — No. 2 / 5 V, min. (AC range)

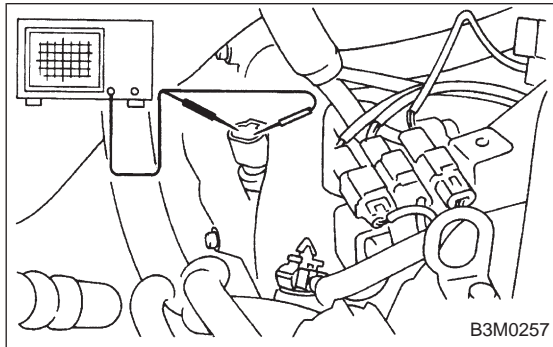

- Using an oscilloscope:
 - (1) Turn ignition switch to OFF.
 - (2) Set oscilloscope to vehicle speed sensor 2.
 - (3) Drive the vehicle at speed greater than 20 km/h (12 MPH).
 - (4) Measure signal voltage.

Specified voltage (V): 5 V, min.

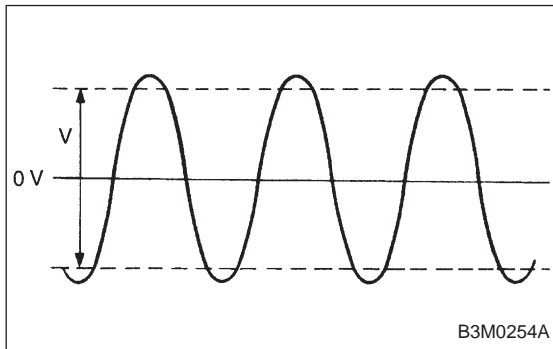

4. Power Window

A: DIAGNOSTICS PROCEDURE-1

Trouble symptom A: All door windows do not operate.

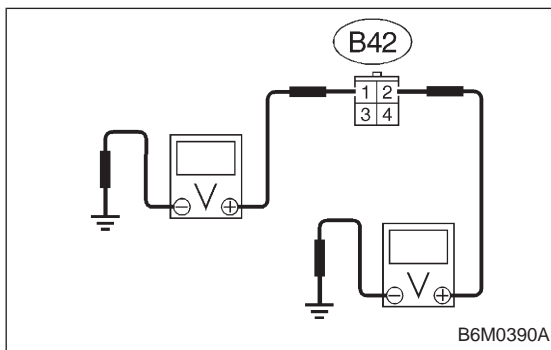
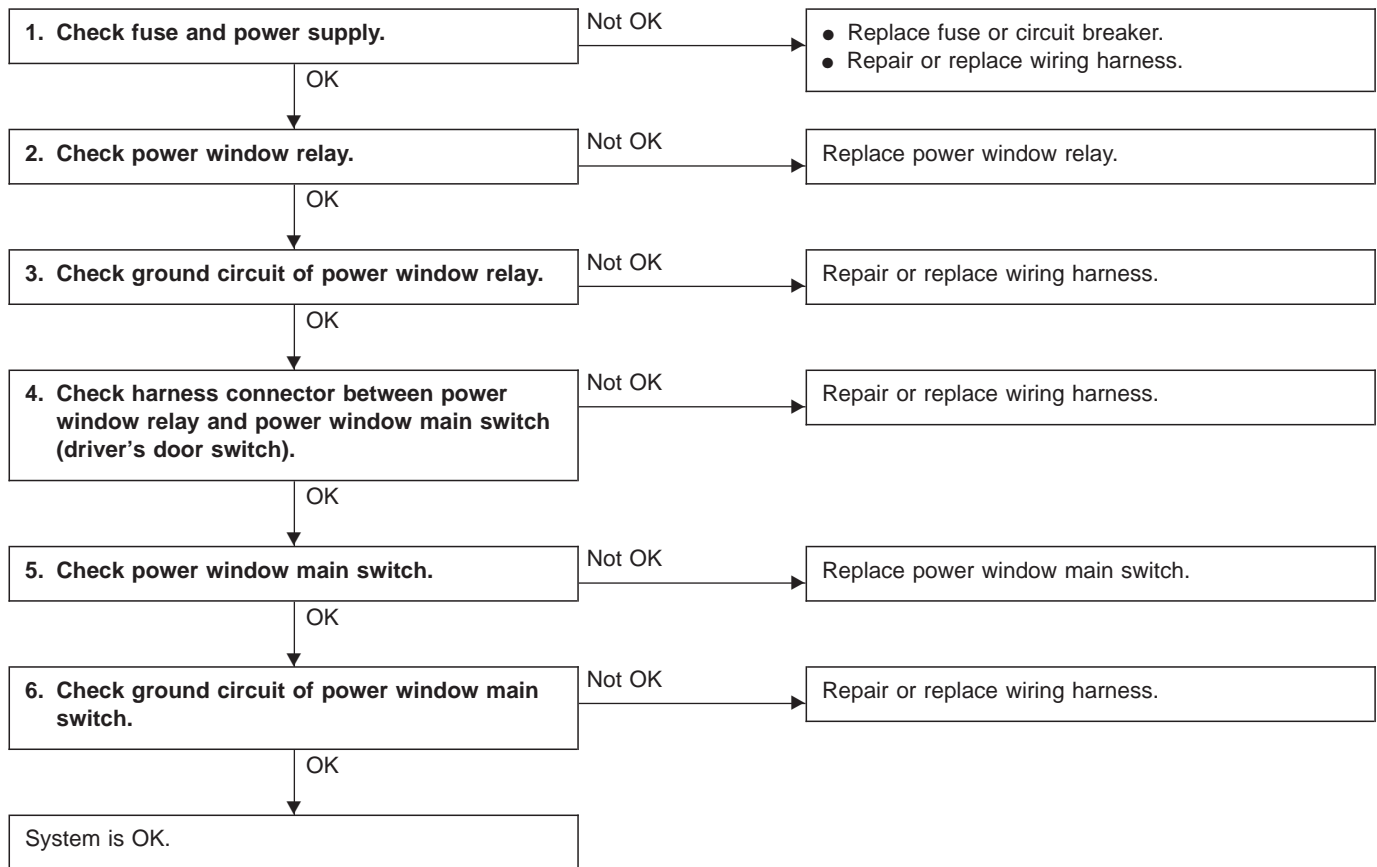

1. CHECK FUSE AND POWER SUPPLY.

- 1) Check fuse No. 15.
- 2) Disconnect connector of power window relay.
- 3) Turn ignition switch to ON.
- 4) Measure voltage between power window relay connector and body.

Connector & terminal / Specified voltage:

- (B42) No. 1 — Body / 10 V, or more**
(B42) No. 2 — Body / 10 V, or more

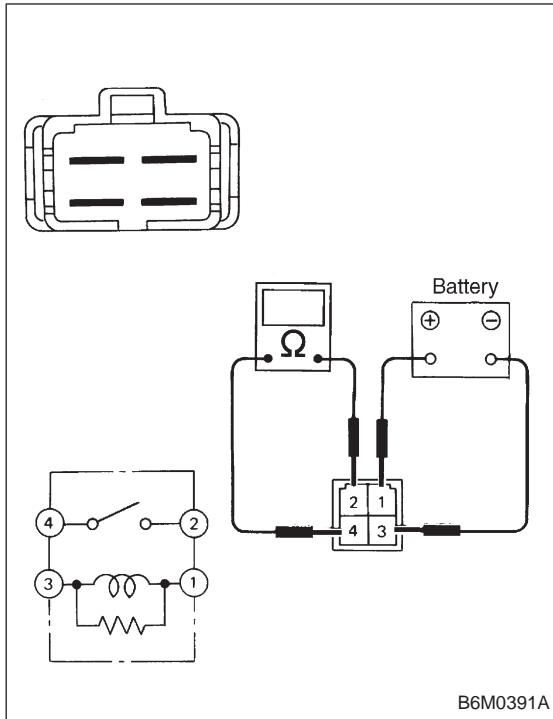

2. CHECK POWER WINDOW RELAY.

- 1) Disconnect connector of power window relay.
- 2) Connect battery to terminal No. 1 and ground terminal No. 3.
- 3) Check continuity between terminals as indicated in table below:

When current flows.	Between terminals No. 2 and No. 4	Continuity exists.
When current does not flow.	Between terminals No. 2 and No. 4	Continuity does not exist.
	Between terminals No. 1 and No. 3	Continuity exists.

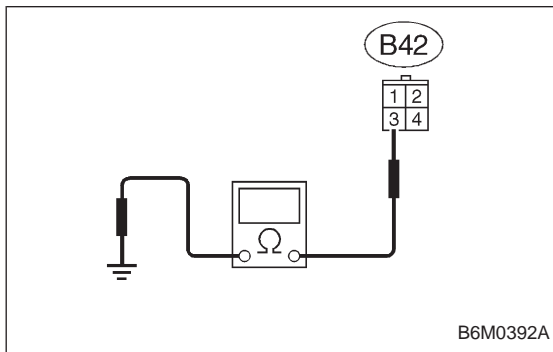

3. CHECK GROUND CIRCUIT OF POWER WINDOW RELAY.

- 1) Disconnect connector of power window relay.
- 2) Measure resistance of harness connector between power window relay and body.

Connector & terminal / Specified resistance:
(B42) No. 3 — Body / 10 Ω, max.

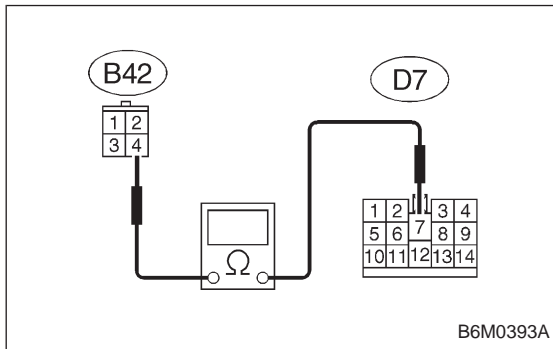

4. CHECK HARNESS CONNECTOR BETWEEN POWER WINDOW RELAY AND POWER WINDOW MAIN SWITCH (DRIVER'S DOOR SWITCH).

- 1) Disconnect connectors of power window relay and power window main switch.
- 2) Measure resistance of harness connector between power window relay and power window main switch.

Connector & terminal / Specified resistance:
(B42) No. 4 — (D7) No. 7 / 10 Ω, max.

5. CHECK POWER WINDOW MAIN SWITCH.

Refer to 6-2 [W16B1] for inspection of power window main switch.

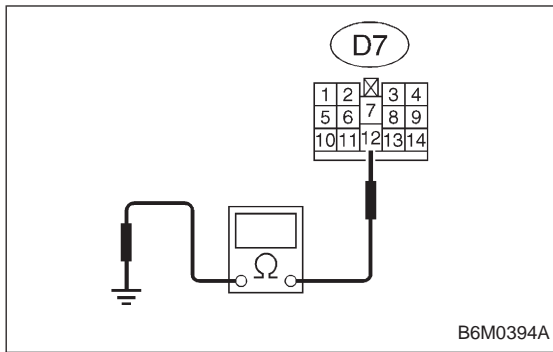

6. CHECK GROUND CIRCUIT OF POWER WINDOW MAIN SWITCH.

- 1) Disconnect connector of power window main switch.
- 2) Measure resistance of harness connector between power window main switch and body.

Connector & terminal / Specified resistance:
(D7) No. 12 — Body / 10 Ω, max.

B: DIAGNOSTICS PROCEDURE-2

Trouble symptom B: Only driver's door window does not operate.

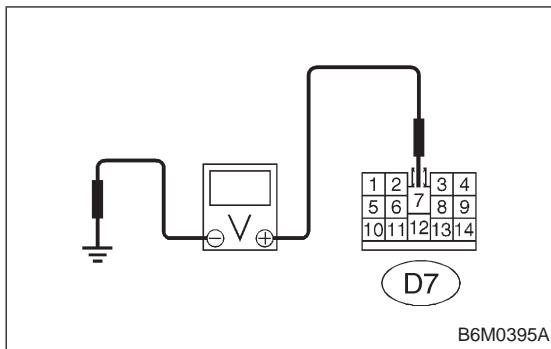
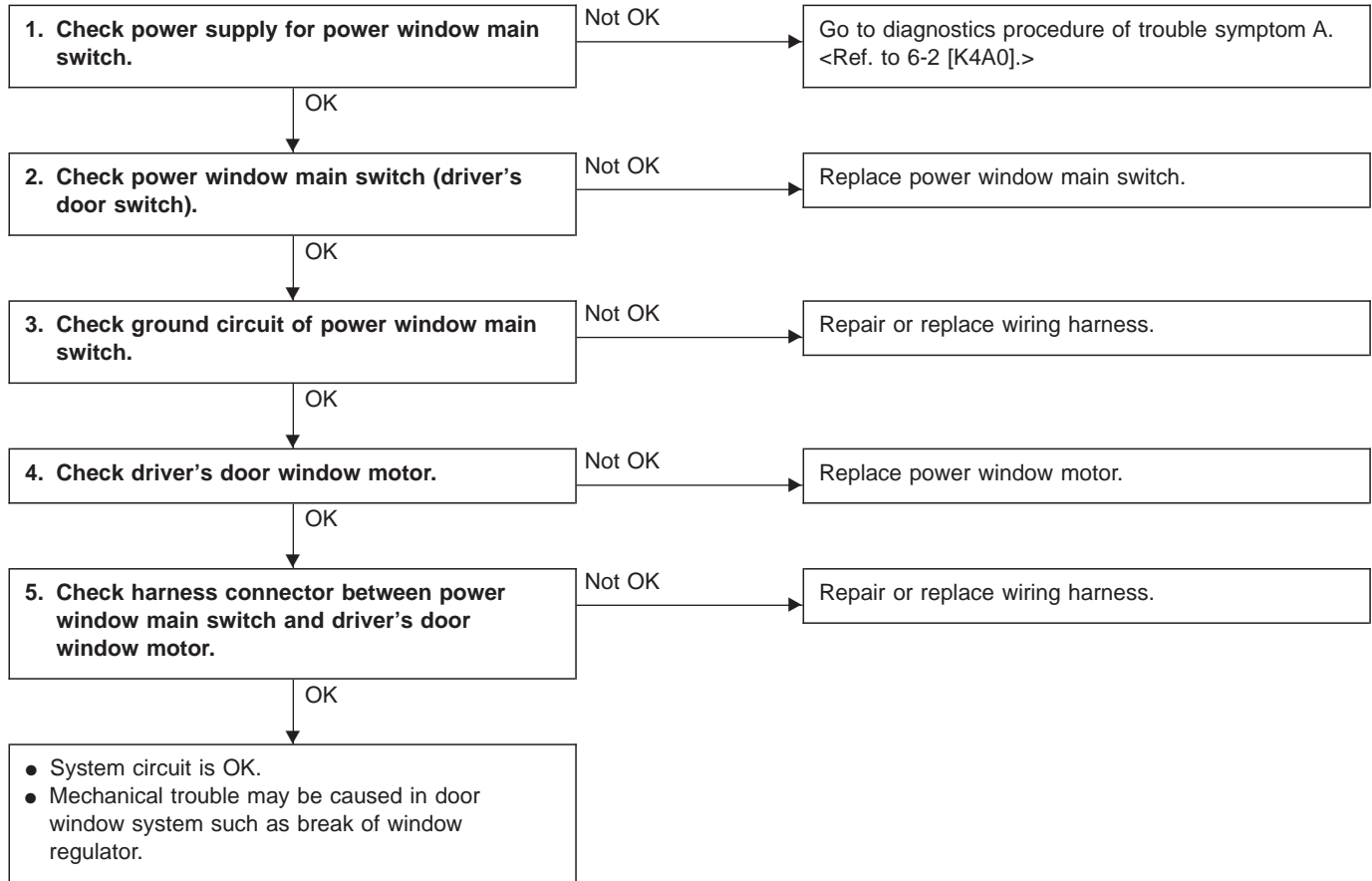
**1. CHECK POWER SUPPLY FOR POWER WINDOW MAIN SWITCH.**

- 1) Disconnect connector of power window main switch.
- 2) Turn ignition switch to ON.
- 3) Measure voltage between power window main switch connector and body.

Connector & terminal / Specified voltage:
(D7) No. 7 — Body / 10 V, or more

2. CHECK POWER WINDOW MAIN SWITCH (DRIVER'S DOOR SWITCH).

Refer to 6-2 [W16B1] for inspection of power window main switch.

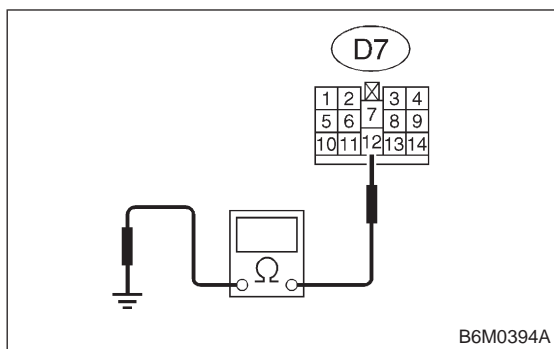

3. CHECK GROUND CIRCUIT OF POWER WINDOW MAIN SWITCH.

- 1) Disconnect connector of power window main switch.
- 2) Measure resistance of harness connector between power window main switch and body.

Connector & terminal / Specified resistance:
(D7) No. 12 — Body / 10 Ω, max.

4. CHECK DRIVER'S DOOR WINDOW MOTOR.

- 1) Disconnect connector of power window motor (driver's door).
- 2) Make sure that power window motor rotates properly when battery voltage is applied to terminals of motor connector.
- 3) Change polarity of battery connections to terminals to ensure that motor rotates in reverse direction.

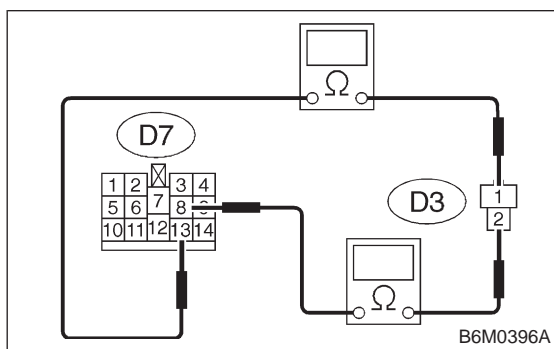

5. CHECK HARNESS CONNECTOR BETWEEN POWER WINDOW MAIN SWITCH AND DRIVER'S DOOR WINDOW MOTOR.

- 1) Disconnect connectors of power window main switch and power window motor (driver's door).
- 2) Measure resistance of harness connector between power window main switch and power window motor.

Connector & terminal / Specified resistance:

LHD model:

(D7) No. 8 — (D3) No. 2 / 10 Ω, max.

(D7) No. 13 — (D3) No. 1 / 10 Ω, max.

RHD model:

(D7) No. 6 — (D3) No. 2 / 10 Ω, max.

(D7) No. 11 — (D3) No. 1 / 10 Ω, max.

C: DIAGNOSTICS PROCEDURE-3

Trouble symptom C: One or more of passenger's door window do not operate.

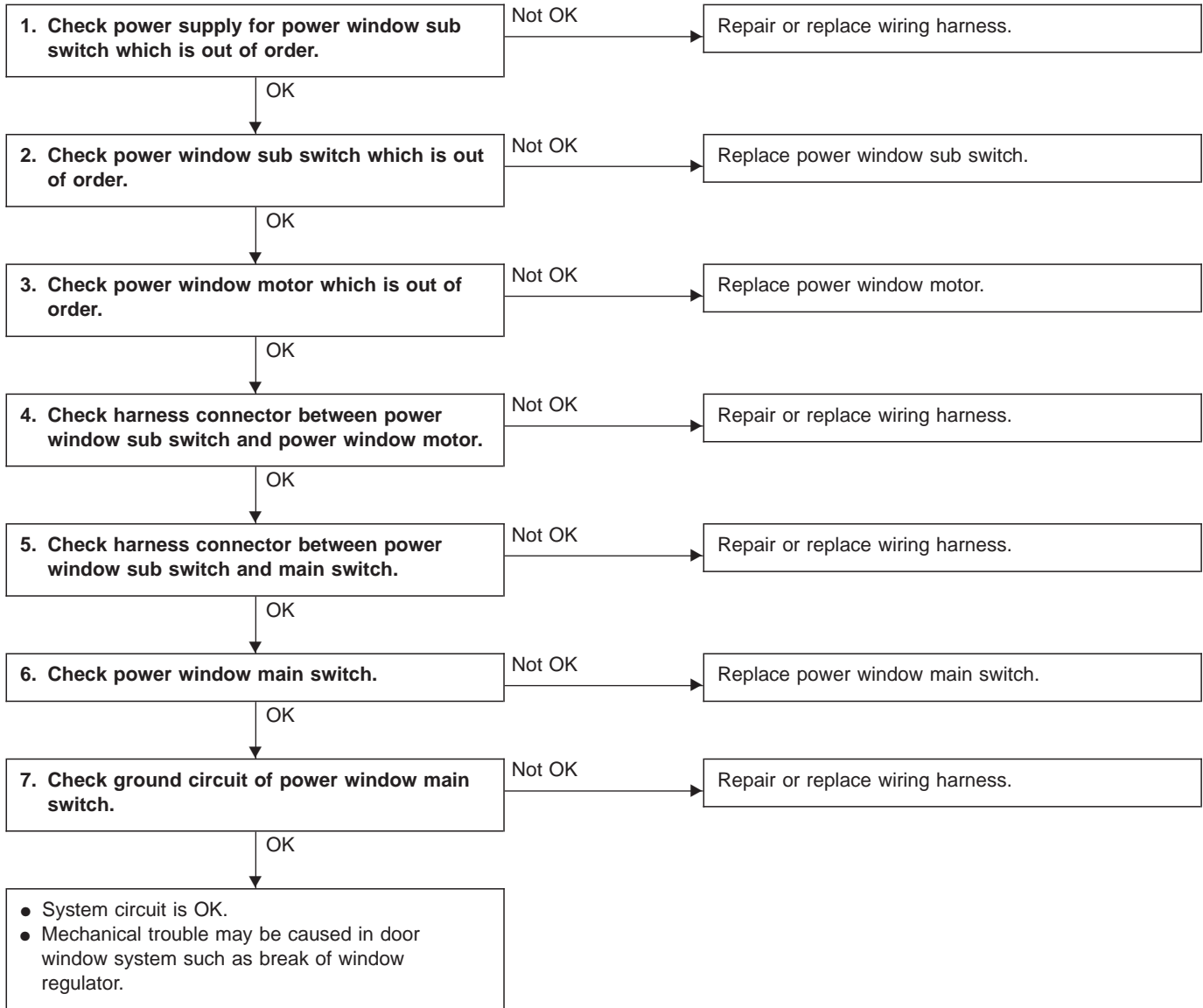

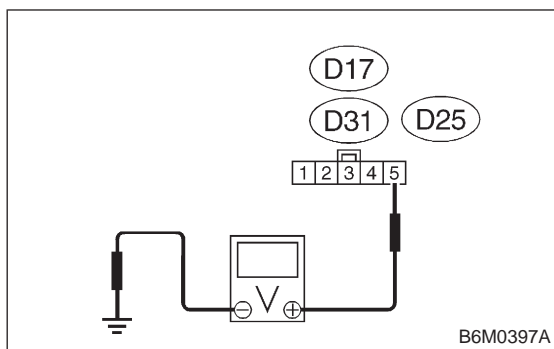

1. CHECK POWER SUPPLY FOR POWER WINDOW SUB SWITCH WHICH IS OUT OF ORDER.

- 1) Disconnect connector of power window sub switch.
- 2) Turn ignition switch to ON.
- 3) Measure voltage between power window sub switch connector and body.

Connector & terminal / Specified voltage:

(D17) No. 5 — Body / 10 V, or more
(Front passenger)

(D31) No. 5 — Body / 10 V, or more (Rear RH)

(D25) No. 5 — Body / 10 V, or more (Rear LH)

2. CHECK POWER WINDOW SUB SWITCH WHICH IS OUT OF ORDER.

Refer to 6-2 [W16B2] for inspection of power window sub switch.

3. CHECK POWER WINDOW MOTOR WHICH IS OUT OF ORDER.

- 1) Disconnect connector of power window motor.
- 2) Make sure that power window motor rotates properly when battery voltage is applied to terminals of motor connector.
- 3) Change polarity of battery connections to terminals to ensure that motor rotates in reverse direction.

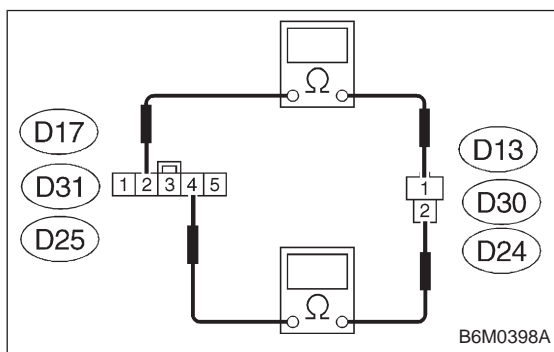

4. CHECK HARNESS CONNECTOR BETWEEN POWER WINDOW SUB SWITCH AND POWER WINDOW MOTOR.

- 1) Disconnect connectors of power window sub switch and power window motor.
- 2) Measure resistance of harness connector between power window sub switch and power window motor.

Connector & terminal / Specified resistance:

(D17) No. 2 — (D13) No. 1 / 10 Ω , max.

(Front passenger)

(D17) No. 4 — (D13) No. 2 / 10 Ω , max.

(Front passenger)

(D31) No. 2 — (D30) No. 1 / 10 Ω , max. (Rear RH)

(D31) No. 4 — (D30) No. 2 / 10 Ω , max. (Rear RH)

(D25) No. 2 — (D24) No. 1 / 10 Ω , max. (Rear LH)

(D25) No. 4 — (D24) No. 2 / 10 Ω , max. (Rear LH)

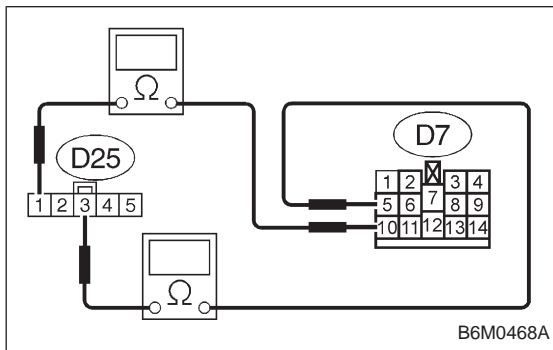
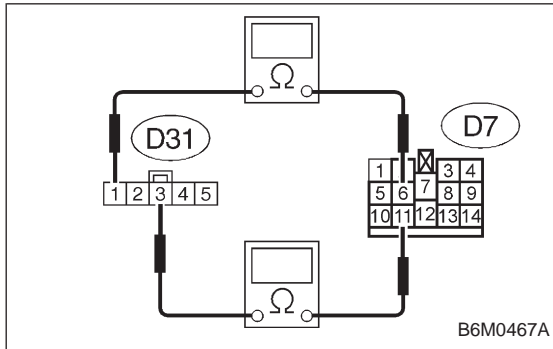
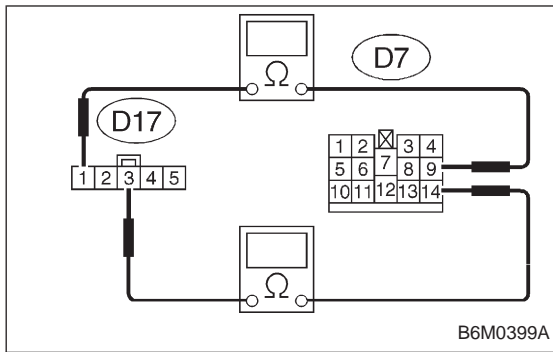

5. CHECK HARNESS CONNECTOR BETWEEN POWER WINDOW SUB SWITCH AND MAIN SWITCH.

- 1) Disconnect connectors of power window sub switch and main switch.
- 2) Measure resistance of harness connector between power window sub switch and main switch.

Connector & terminal / Specified resistance:

LHD model:

(D17) No. 1 — (D7) No. 9 / 10 Ω , max.

(Front passenger)

(D17) No. 3 — (D7) No. 14 / 10 Ω , max.

(Front passenger)

(D31) No. 1 — (D7) No. 6 / 10 Ω , max. (Rear RH)

(D31) No. 3 — (D7) No. 11 / 10 Ω , max. (Rear RH)

(D25) No. 1 — (D7) No. 10 / 10 Ω , max. (Rear LH)

(D25) No. 3 — (D7) No. 5 / 10 Ω , max. (Rear LH)

RHD model:

(D17) No. 1 — (D7) No. 10 / 10 Ω , max.

(Front passenger)

(D17) No. 3 — (D7) No. 5 / 10 Ω , max.

(Front passenger)

(D31) No. 1 — (D7) No. 9 / 10 Ω , max. (Rear RH)

(D31) No. 3 — (D7) No. 14 / 10 Ω , max. (Rear RH)

(D25) No. 1 — (D7) No. 13 / 10 Ω , max. (Rear LH)

(D25) No. 3 — (D7) No. 8 / 10 Ω , max. (Rear LH)

6. CHECK POWER WINDOW MAIN SWITCH.

Refer to 6-2 [W16B1] for inspection of power window main switch.

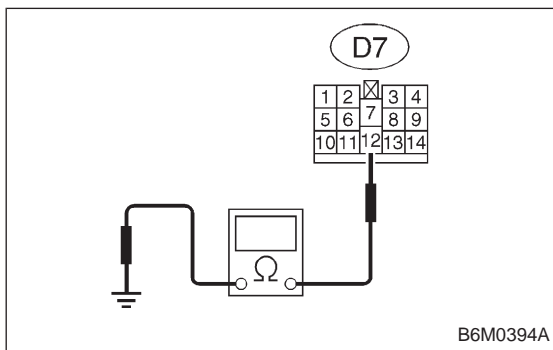

7. CHECK GROUND CIRCUIT OF POWER WINDOW MAIN SWITCH.

- 1) Disconnect connector of power window main switch.
- 2) Measure resistance of harness connector between power window main switch and body.

Connector & terminal / Specified resistance:

(D7) No. 12 — Body / 10 Ω , max.

5. Remote Controlled Rearview Mirror A: DIAGNOSTICS PROCEDURE

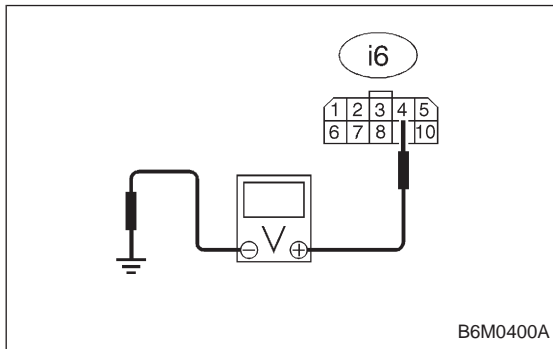
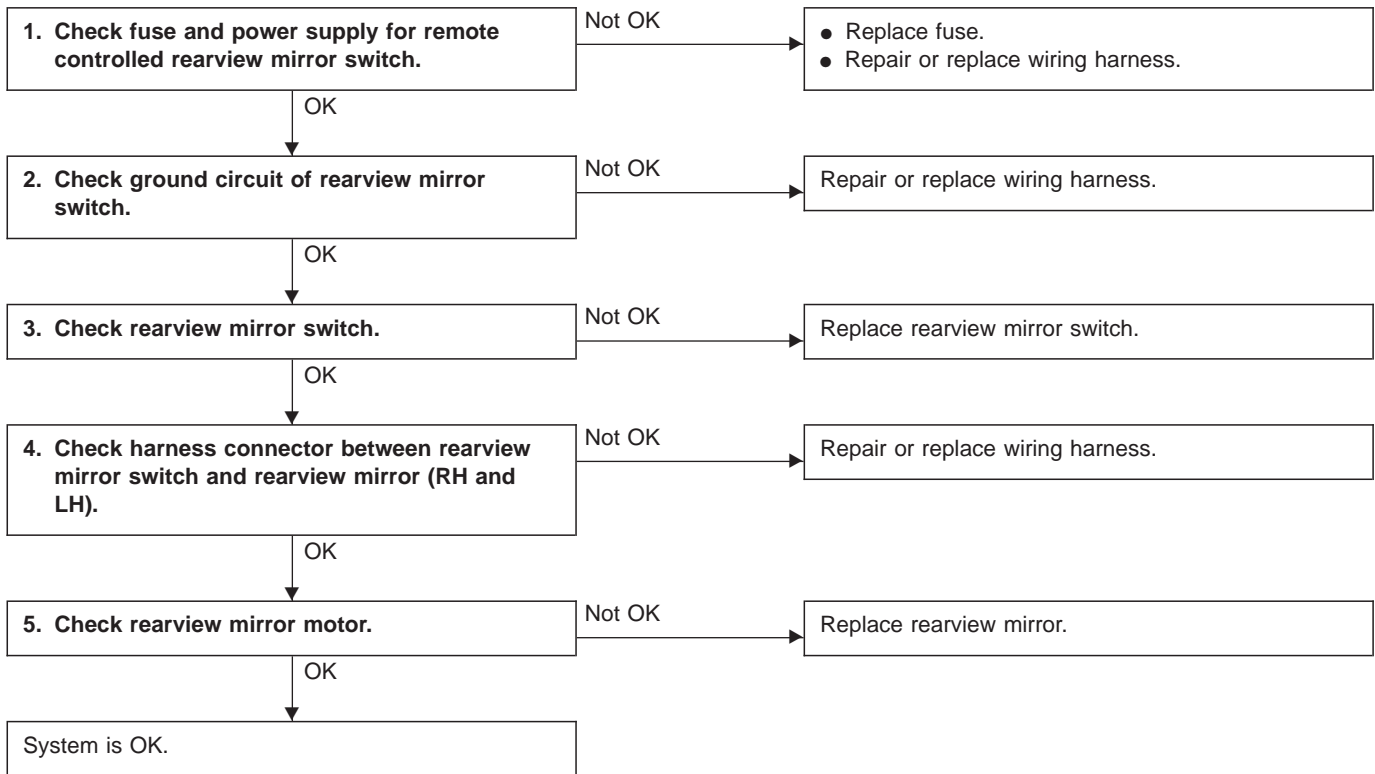

1. CHECK FUSE AND POWER SUPPLY FOR REMOTE CONTROLLED REARVIEW MIRROR SWITCH.

- 1) Check fuse No. 3.
- 2) Disconnect connector of rearview mirror switch.
- 3) Turn ignition switch to ON.
- 4) Measure voltage between rearview mirror switch connector and body.

Connector & terminal / Specified voltage:
(i6) No. 4 — Body / 10 V, or more

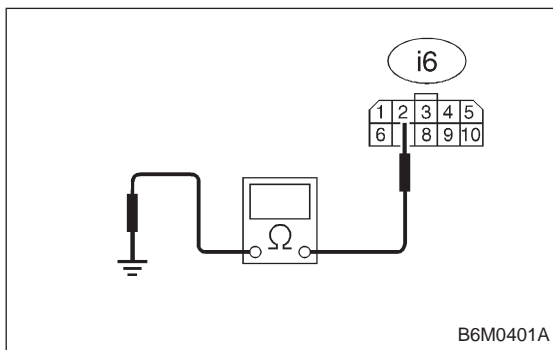

2. CHECK GROUND CIRCUIT OF REARVIEW MIRROR SWITCH.

- 1) Disconnect connector of rearview mirror switch.
- 2) Measure resistance of harness connector between rearview mirror switch and body.

Connector & terminal / Specified resistance:
(i6) No. 2 — Body / 10 Ω, max.

3. CHECK REARVIEW MIRROR SWITCH.

Refer to 6-2 [W18B1] for inspection of rearview mirror switch.

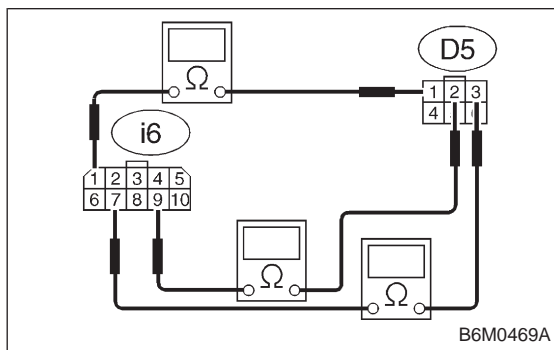
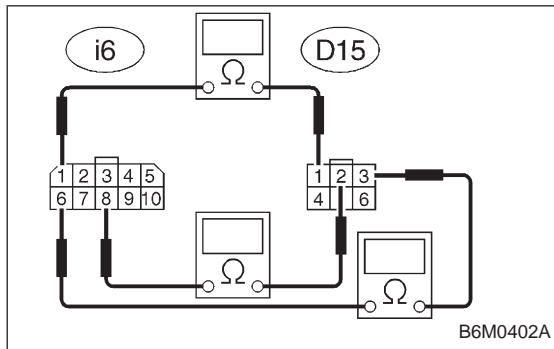
**4. CHECK HARNESS CONNECTOR BETWEEN REARVIEW MIRROR SWITCH AND REARVIEW MIRROR (RH AND LH).**

- 1) Disconnect connectors of rearview mirror switch and rearview mirror.
- 2) Measure resistance of harness connector between rearview mirror switch and rearview mirror.

Connector & terminal / Specified resistance:**LHD model:**

- (i6) No. 1 — (D15) No. 1 / 10 Ω, max. (RH)
- (i6) No. 8 — (D15) No. 2 / 10 Ω, max. (RH)
- (i6) No. 6 — (D15) No. 3 / 10 Ω, max. (RH)
- (i6) No. 1 — (D5) No. 1 / 10 Ω, max. (LH)
- (i6) No. 9 — (D5) No. 2 / 10 Ω, max. (LH)
- (i6) No. 7 — (D5) No. 3 / 10 Ω, max. (LH)

RHD model:

- (i6) No. 1 — (D5) No. 1 / 10 Ω, max. (RH)
- (i6) No. 8 — (D5) No. 2 / 10 Ω, max. (RH)
- (i6) No. 6 — (D5) No. 3 / 10 Ω, max. (RH)
- (i6) No. 1 — (D15) No. 1 / 10 Ω, max. (LH)
- (i6) No. 9 — (D15) No. 2 / 10 Ω, max. (LH)
- (i6) No. 7 — (D15) No. 3 / 10 Ω, max. (LH)

5. CHECK REARVIEW MIRROR MOTOR.

Refer to 6-2 [W18B2] for inspection of rearview mirror motor.

6. Security System

A: ELECTRICAL COMPONENTS LOCATION

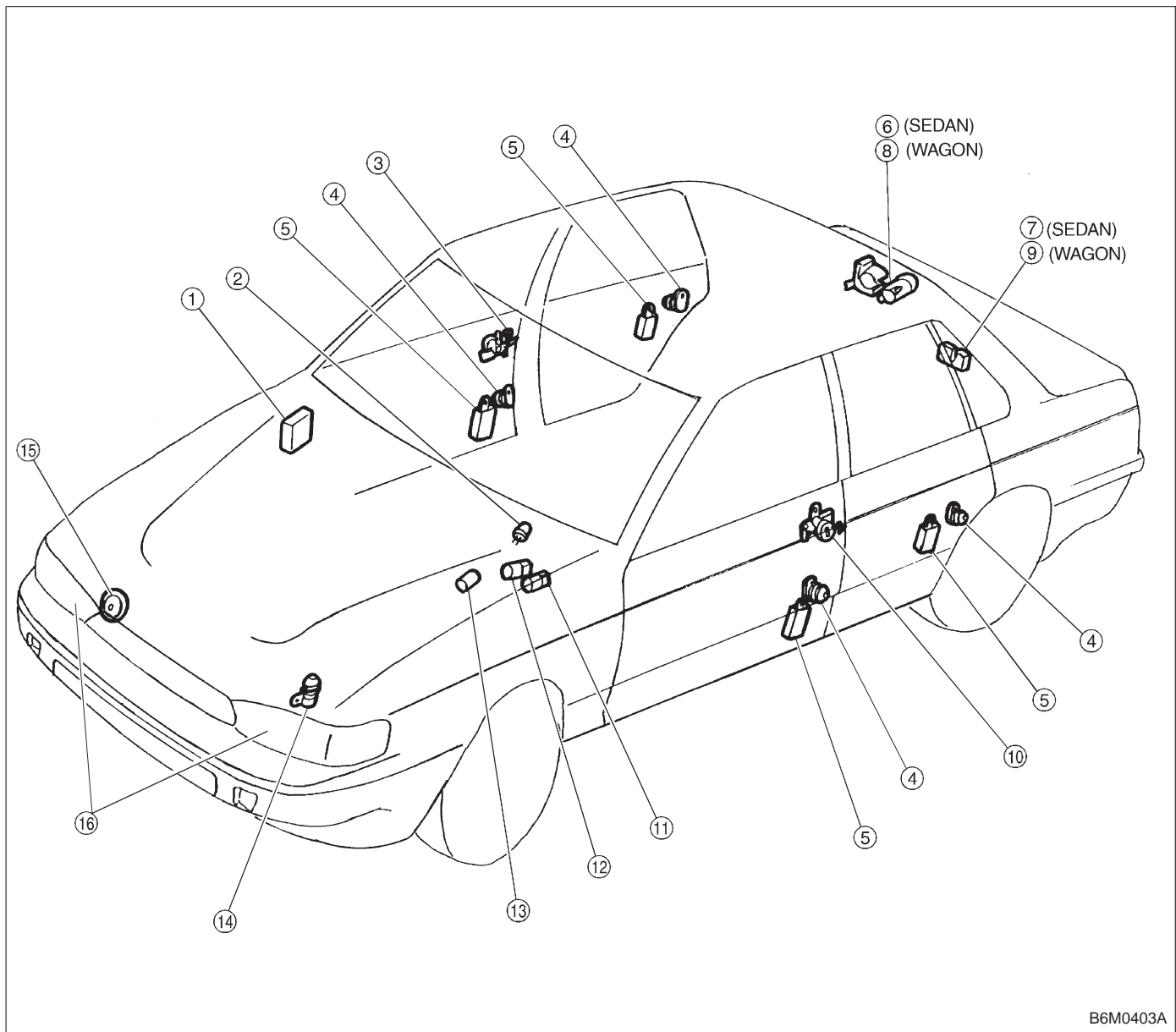

B6M0403A

- | | |
|---|--|
| ① Security control module | ⑨ Rear gate switch (WAGON) |
| ② Security indicator light | ⑩ LH door key cylinder lock/unlock switch (built-in tamper switch) |
| ③ RH door key cylinder lock/unlock switch (built-in tamper switch) | ⑪ Starter interrupt relay |
| ④ Door switch | ⑫ Headlight alarm relay |
| ⑤ Door lock/unlock switch | ⑬ Ignition switch (ACC position) |
| ⑥ Trunk lid key cylinder unlock switch (SEDAN) (built-in tamper switch) | ⑭ Engine hood switch |
| ⑦ Trunk lid switch (SEDAN) | ⑮ Horn |
| ⑧ Rear gate key cylinder lock/unlock switch (WAGON) | ⑯ Headlight |

B: SCHEMATIC

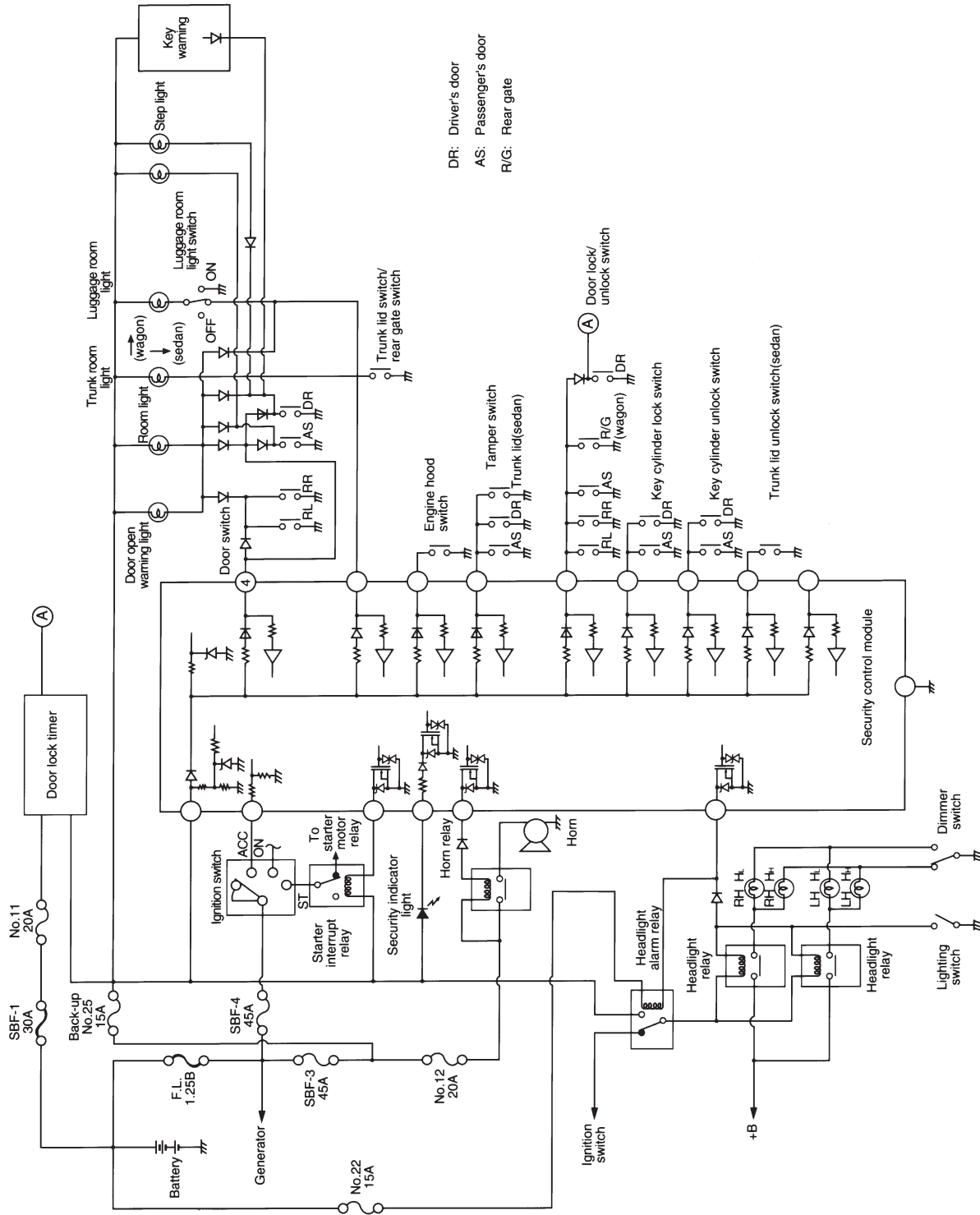

B6H0319

C: CONTROL MODULE I/O SIGNAL

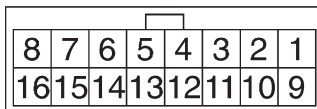

B6M0405

Content	Terminal No.	Measuring conditions and I/O signals (Ignition switch ACC position)
Door lock/unlock switch	1 (INPUT)	<ul style="list-style-type: none"> Battery voltage is present when all doors and rear gate (WAGON) are locked. "0" volt is present when one of the doors or rear gate (WAGON) is unlocked.
Key cylinder lock switch	2 (INPUT)	<ul style="list-style-type: none"> "0" volt is present when key cylinder is turned to LOCK position. Battery voltage is present when key cylinder is in positions other than LOCK.
Tamper switch	3 (INPUT)	<ul style="list-style-type: none"> Battery voltage is present when key cylinder switch is installed to key cylinder. "0" volt is present when key cylinder switch is removed from key cylinder.
Door switch	4 (INPUT)	<ul style="list-style-type: none"> Battery voltage is present when all doors are closed. "0" volt is present when one of the doors is open.
Starter interrupt relay	5 (OUTPUT)	<ul style="list-style-type: none"> Battery voltage is present when ignition switch is turned ACC or ON. "0" volt is present when security system is in alarm state.
Ignition switch (ACC)	6 (INPUT)	<ul style="list-style-type: none"> Battery voltage is present when ignition switch is turned ACC or ON. "0" volt is present when ignition switch is turned OFF.
Security indicator light	7 (OUTPUT)	<ul style="list-style-type: none"> Battery voltage is present when indicator light goes off. "0" volt is present when indicator light illuminates.
Power supply (back-up)	8	Battery voltage is constantly present.
Ground	9	—
Engine hood switch	10 (INPUT)	<ul style="list-style-type: none"> Battery voltage is present when engine hood is closed. "0" volt is present when engine hood is open.
Trunk lid switch (SEDAN) Rear gate switch (WAGON)	11 (INPUT)	<ul style="list-style-type: none"> Battery voltage is present when trunk lid or rear gate is closed. "0" volt is present when trunk lid or rear gate is open.
Headlight alarm relay	12 (OUTPUT)	<ul style="list-style-type: none"> Battery voltage is present when ignition switch is turned ACC or ON. "0" volt and battery voltage repeats in alarm state. (Headlights flash intermittently at 0.2 sec. ON and 0.6 sec. OFF intervals).
Horn relay	13 (OUTPUT)	<ul style="list-style-type: none"> Battery voltage is present when ignition switch is turned ACC or ON. "0" volt and battery voltage repeats in alarm state. (Horn sounds intermittently at 0.2 sec. ON and 0.6 sec. OFF intervals.)
Key cylinder unlock switch	14 (INPUT)	<ul style="list-style-type: none"> "0" volt is present when key cylinder is turned to UNLOCK position. Battery voltage is present when key cylinder is in positions other than UNLOCK.
Trunk lid key cylinder unlock switch (SEDAN)	15 (INPUT)	<ul style="list-style-type: none"> "0" volt is present when trunk lid key cylinder is turned to UNLOCK position. Battery voltage is present when trunk lid key cylinder is in positions other than UNLOCK.

D: BASIC DIAGNOSTICS PROCEDURE

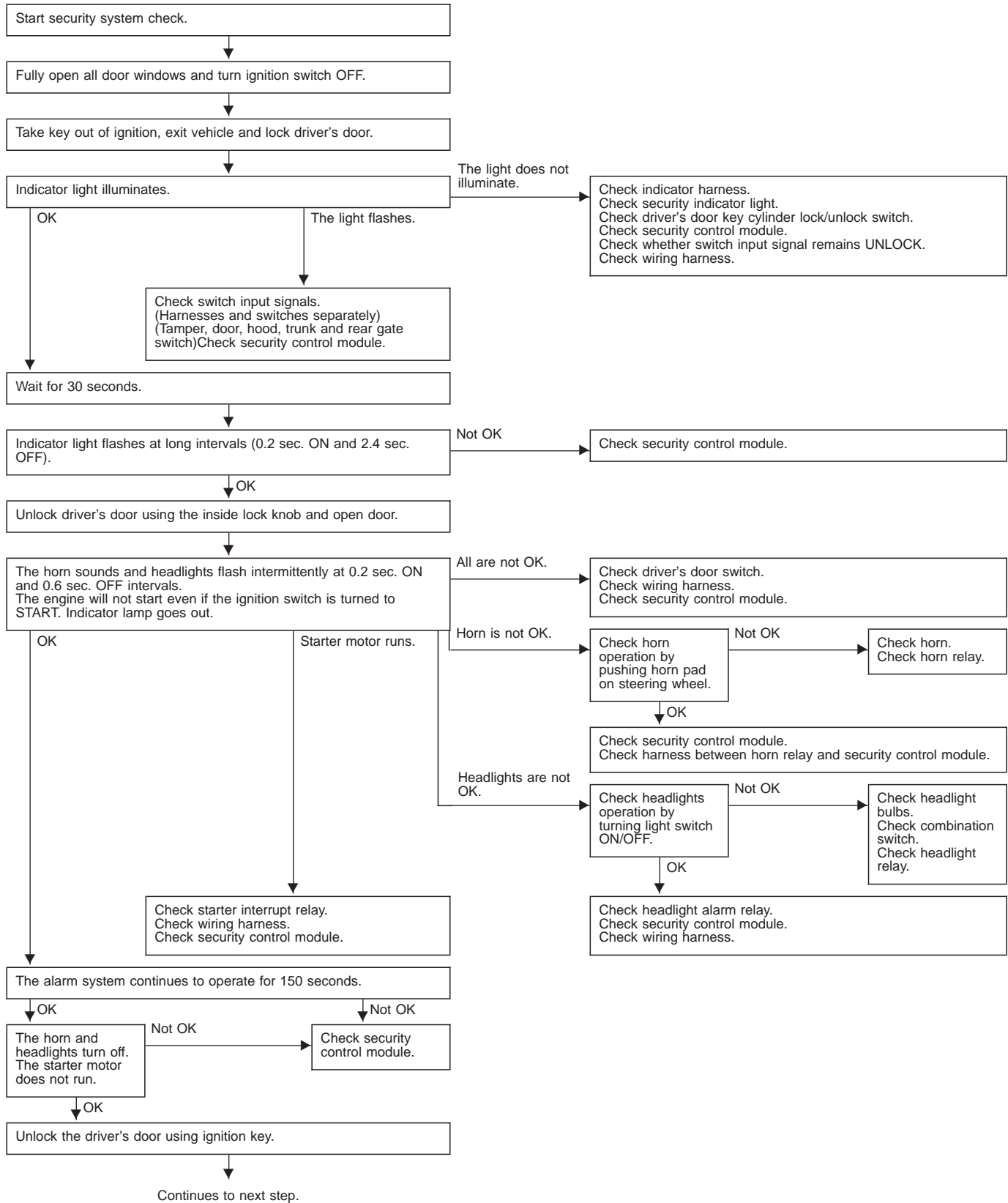

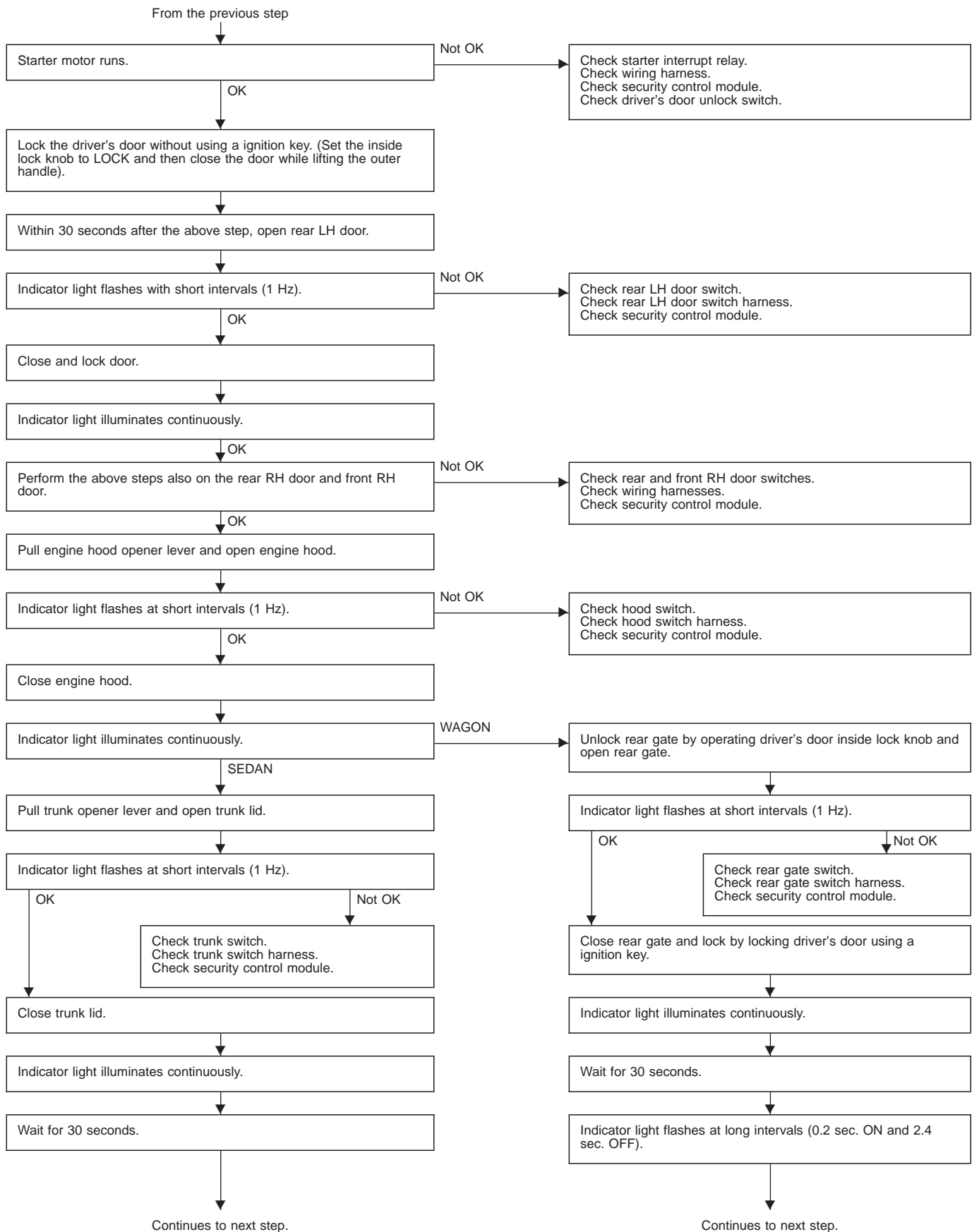

6. Security System

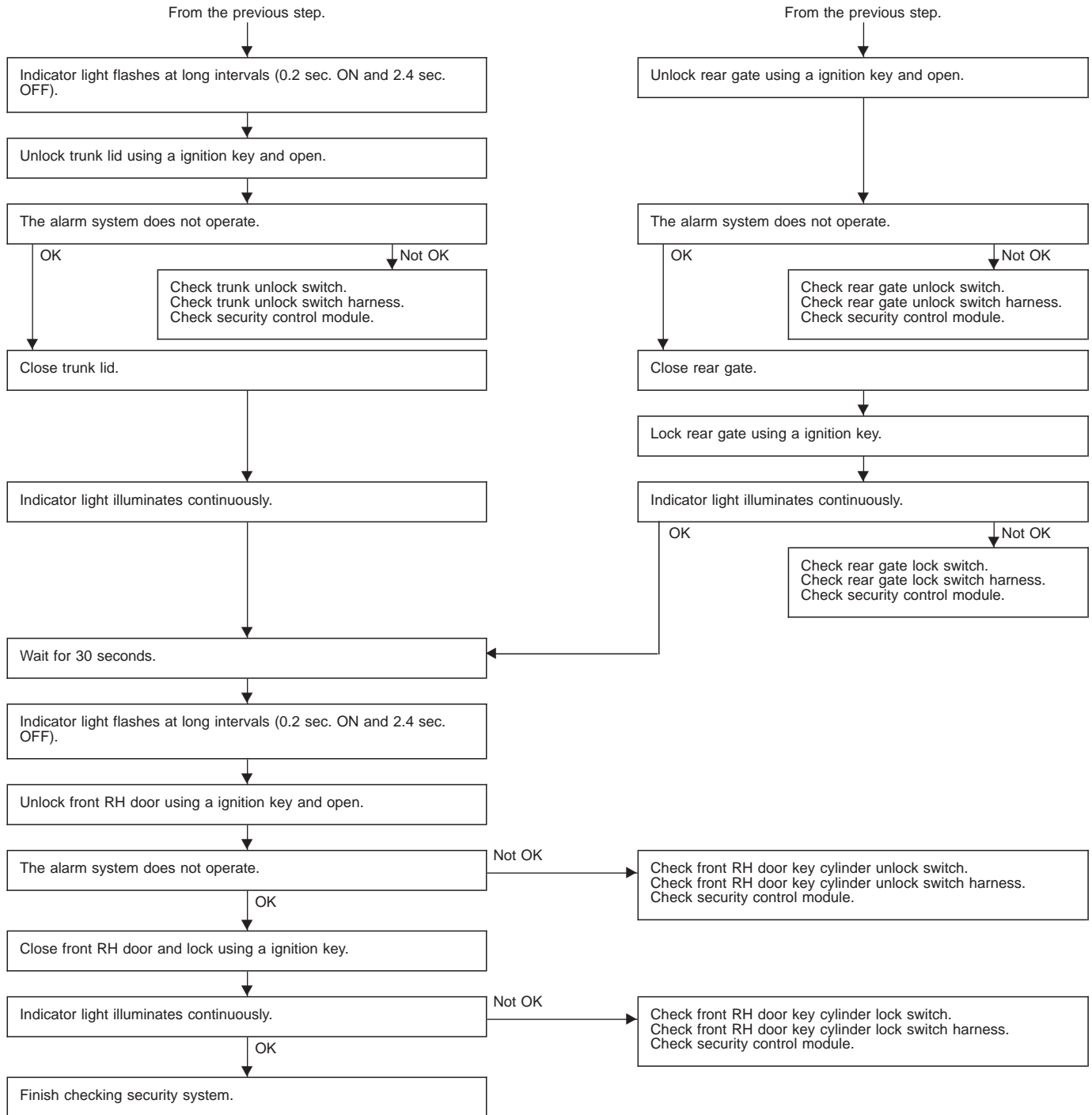

E: DIAGNOSTICS PROCEDURE FOR SECURITY CONTROL MODULE POWER SUPPLY/GROUND CIRCUIT

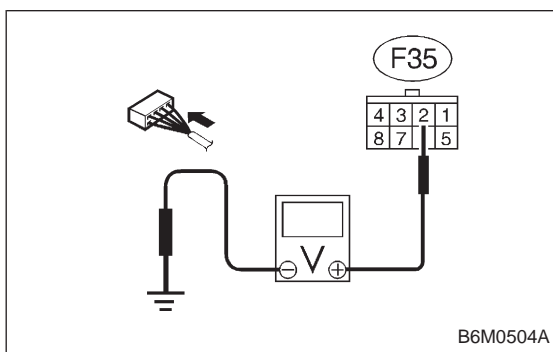
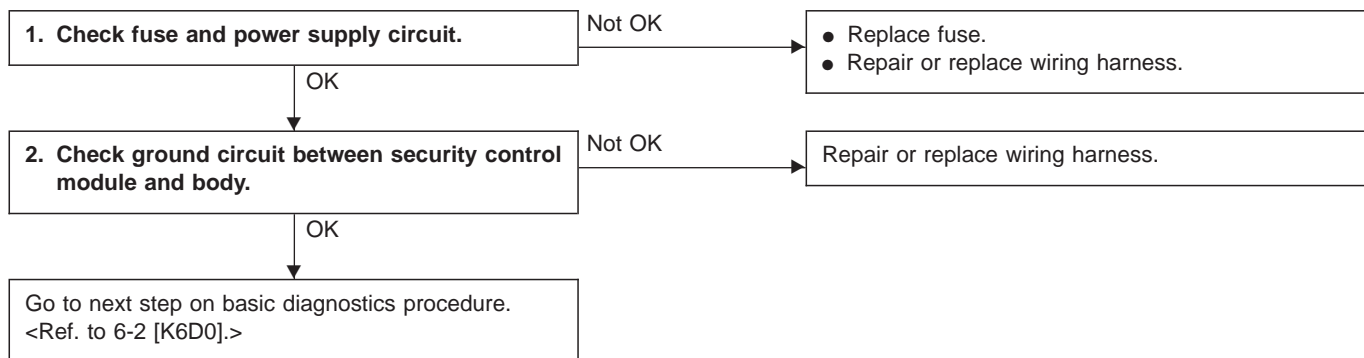

1. CHECK FUSE AND POWER SUPPLY CIRCUIT.

- 1) Check fuse No. 25.
- 2) Measure voltage between main fuse box connector and body.

Connector & terminal / Specified voltage:
(F35) No. 2 — Body / 10 V, or more

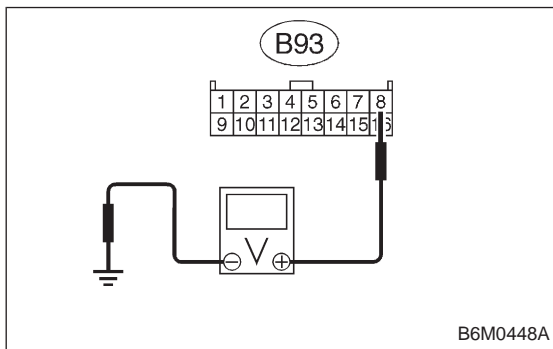

- 3) Disconnect connector from security control module.
- 4) Measure voltage between security control module connector and body.

Connector & terminal / Specified voltage:
(B93) No. 8 — Body / 10 V, or more

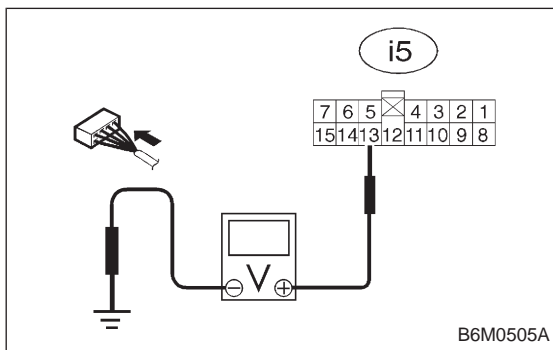

- 5) Check fuse No. 3.
- 6) Turn ignition switch to ACC.
- 7) Measure voltage between fuse and relay box connector and body.

Connector & terminal / Specified voltage:
(i5) No. 13 — Body / 10 V, or more

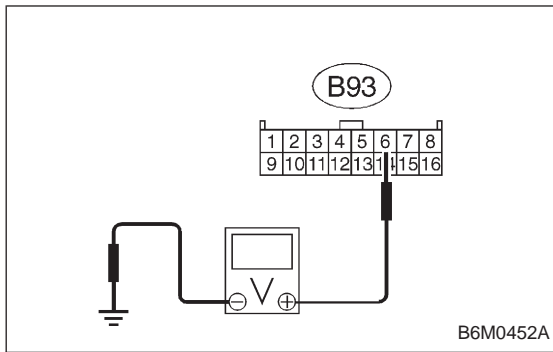

- 8) Disconnect connector from security control module.
- 9) Measure voltage between security control module connector and body.

Connector & terminal / Specified voltage:
(B93) No. 6 — Body / 10 V, or more

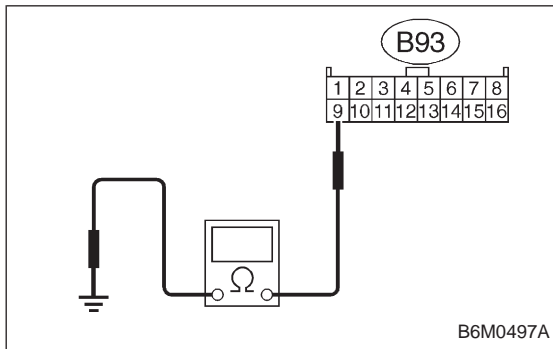

2. CHECK GROUND CIRCUIT BETWEEN SECURITY CONTROL MODULE AND BODY.

- 1) Turn ignition switch to OFF.
- 2) Disconnect connector of security control module.
- 3) Measure resistance of harness connector between security control module and body.

Connector & terminal / Specified resistance:
(B93) No. 9 — Body / 10 Ω , max.

F: DIAGNOSTICS PROCEDURE FOR SECURITY INDICATOR LIGHT AND INDICATOR LIGHT CIRCUIT

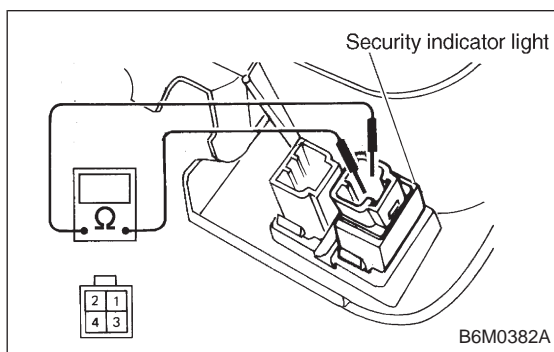
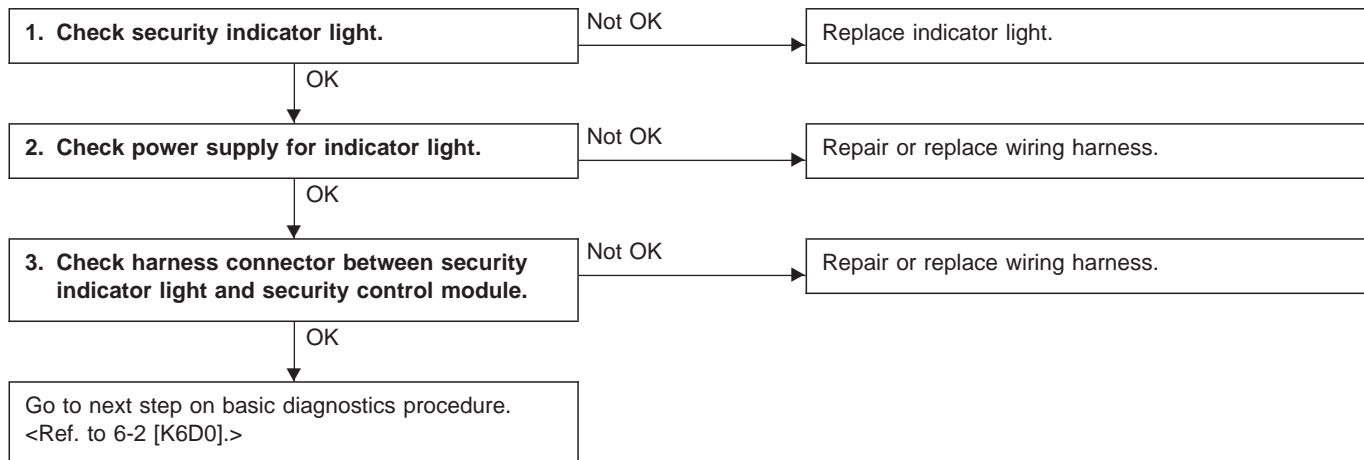

1. CHECK SECURITY INDICATOR LIGHT.

- 1) Remove security indicator light.
- 2) Measure resistance between security indicator light connector terminals.

Terminals / Specified resistance:
No. 2 — No. 4 / Approx. 120 Ω

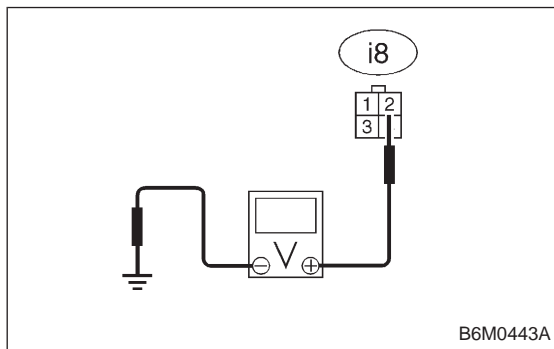

2. CHECK POWER SUPPLY FOR INDICATOR LIGHT.

- 1) Disconnect connector of security indicator light.
- 2) Measure voltage between security indicator light connector and body.

Connector & terminal / Specified voltage:
(i8) No. 2 — Body / 10 V, or more

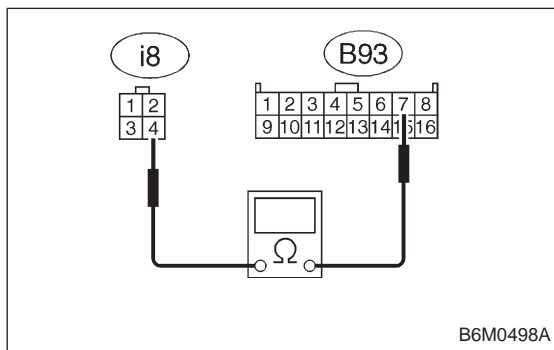

3. CHECK HARNESS CONNECTOR BETWEEN SECURITY INDICATOR LIGHT AND SECURITY CONTROL MODULE.

- 1) Disconnect connectors of security indicator light and security control module.
- 2) Measure resistance of harness connector between security indicator light and security control module.

Connector & terminal / Specified resistance:
(i8) No. 4 — (B93) No. 7 / 10 Ω , max.

G: DIAGNOSTICS PROCEDURE FOR DOOR SWITCH SIGNAL

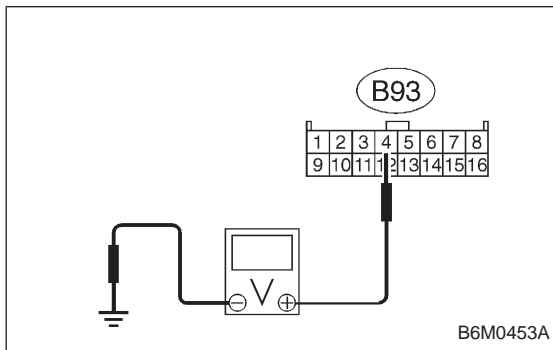
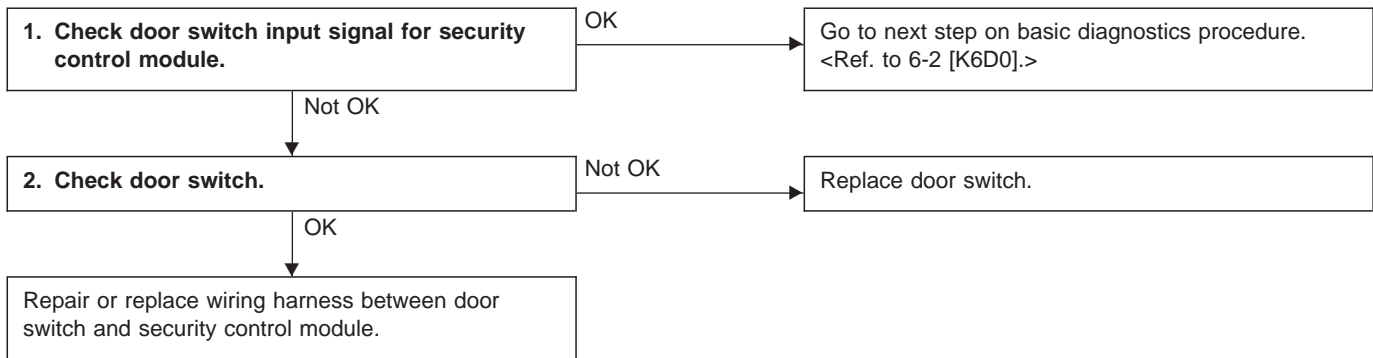

1. CHECK DOOR SWITCH INPUT SIGNAL FOR SECURITY CONTROL MODULE.

- 1) Remove security control module without disconnecting connector.
- 2) Turn door switch ON/OFF and measure voltage between security control module connector and body.

Connector & terminal / Specified voltage:

**(B93) No. 4 — Body / 10 V, or more (Door closed)
/ 1 V, max. (Door opened)**

NOTE:

When one of the doors is open, the voltage may be 1 V, max.

2. CHECK DOOR SWITCH.

Refer to 6-2 [W8B1] for inspection of door switch.

NOTE:

The door switch is used for interior light also.

H: DIAGNOSTICS PROCEDURE FOR ENGINE HOOD SWITCH SIGNAL

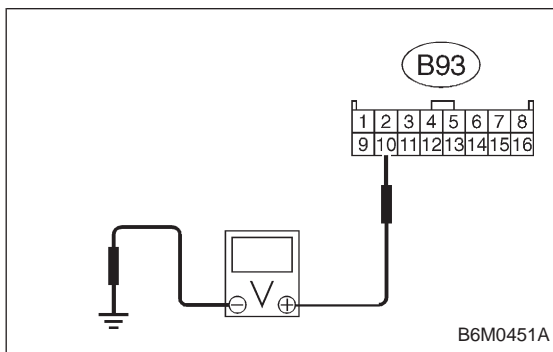
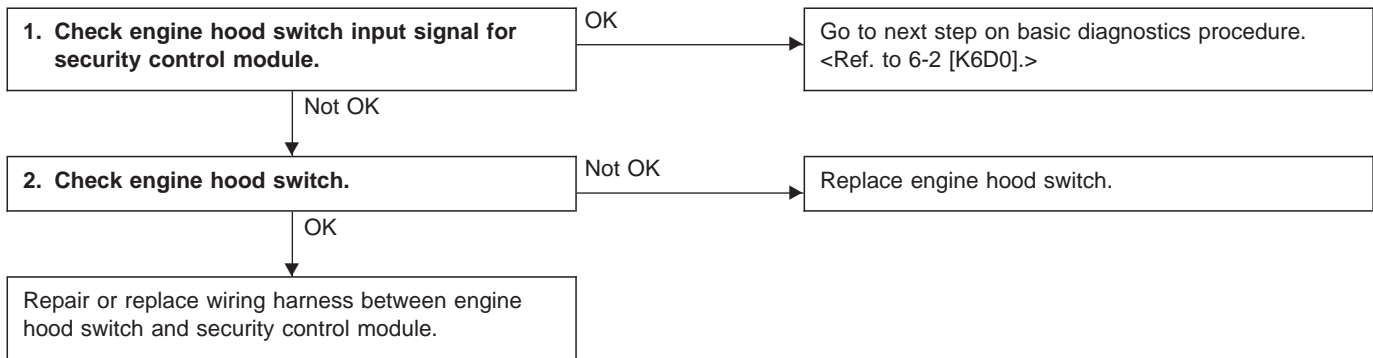

1. CHECK ENGINE HOOD SWITCH INPUT SIGNAL FOR SECURITY CONTROL MODULE.

- 1) Remove security control module without disconnecting connector.
- 2) Turn engine hood switch ON/OFF and measure voltage between security control module connector and body.

Connector & terminal / Specified voltage:

(B93) No. 10 — Body / 10 V, or more (Hood closed)

/ 1 V, max. (Hood opened)

2. CHECK ENGINE HOOD SWITCH.

Refer to 6-2 [W22B3] for inspection of engine hood switch.

I: DIAGNOSTICS PROCEDURE FOR TRUNK LID SWITCH (SEDAN) OR REAR GATE SWITCH (WAGON) SIGNAL

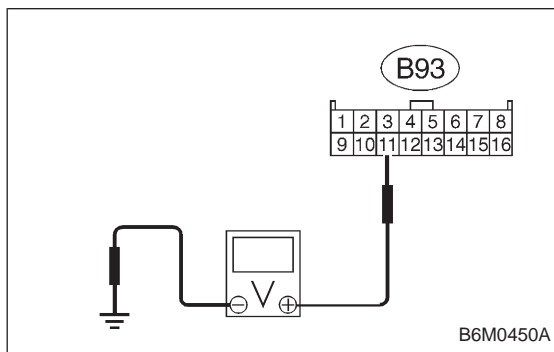
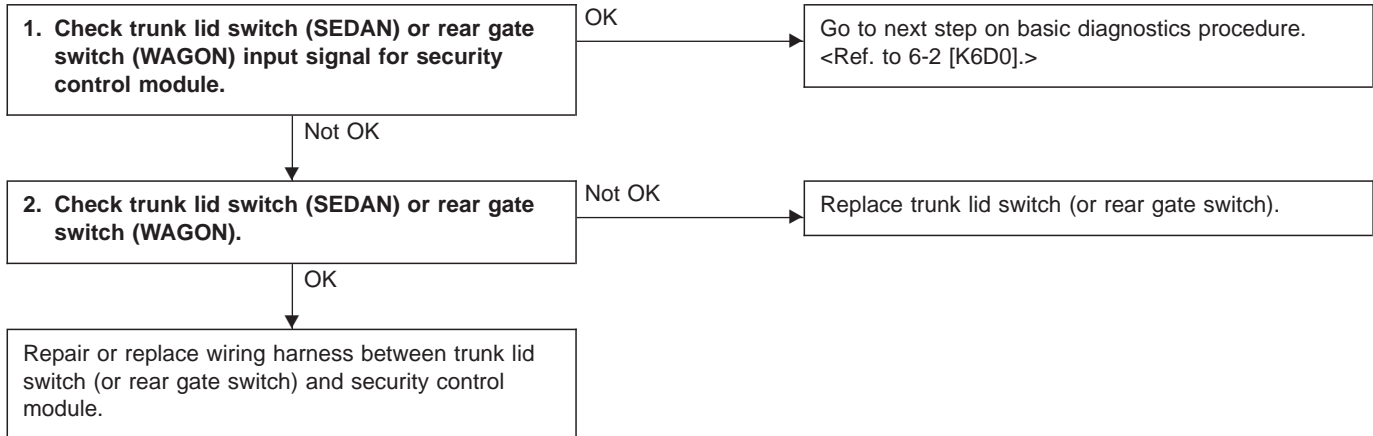

1. CHECK TRUNK LID SWITCH (SEDAN) OR REAR GATE SWITCH (WAGON) INPUT SIGNAL FOR SECURITY CONTROL MODULE.

- 1) Remove security control module without disconnecting connector.
- 2) Turn trunk lid switch (or rear gate switch) ON/OFF and measure voltage between security control module connector and body.

Connector & terminal / Specified voltage:

**(B93) No. 11 — Body / 10 V, or more
(Lid or gate closed)
/ 1 V, max.
(Lid or gate opened)**

2. CHECK TRUNK LID SWITCH (SEDAN) OR REAR GATE SWITCH (WAGON).

Refer to 6-2 [W8B2/W8B3] for inspection of trunk lid switch/rear gate switch.

NOTE:

The trunk lid switch/rear gate switch is used for both trunk room light/luggage room light.

J: DIAGNOSTICS PROCEDURE FOR DOOR LOCK/UNLOCK SWITCH SIGNAL

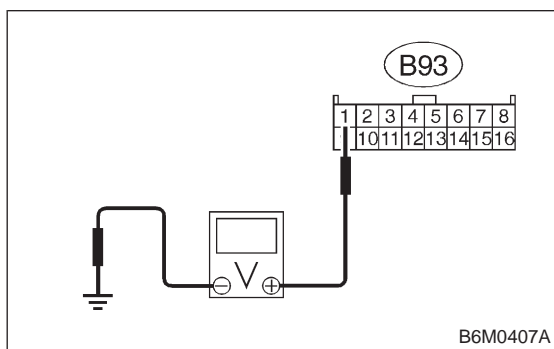
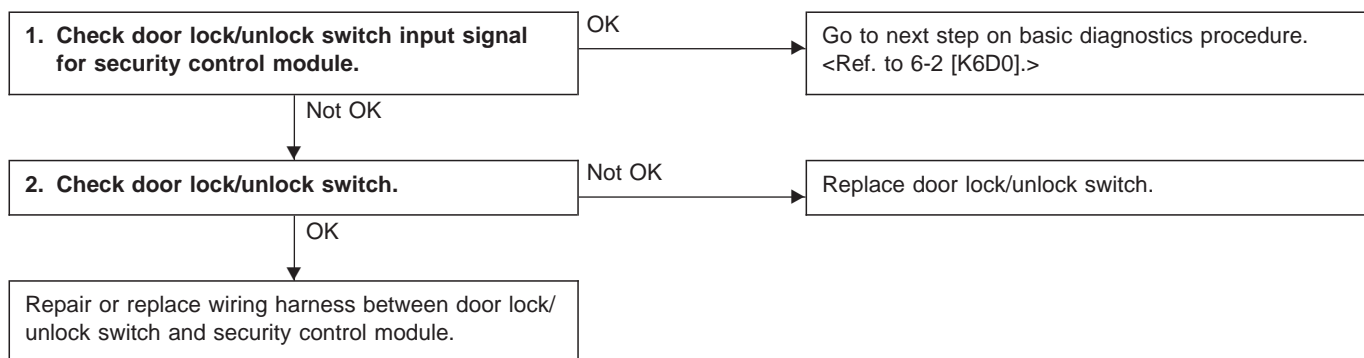

1. CHECK DOOR LOCK/UNLOCK SWITCH INPUT SIGNAL FOR SECURITY CONTROL MODULE.

- 1) Remove security control module without disconnecting connector.
- 2) Close all the doors and rear gate (WAGON), and lock with ignition key.
- 3) Measure voltage between security control module connector and body.

Connector & terminal / Specified voltage:
(B93) No. 1 — Body / 10 V, or more

NOTE:

When one of the door (driver, passenger or rear gate) lock knobs is in unlocked position, the voltage may be 1 V, max.

- 4) Unlock the door with ignition key.
- 5) Measure voltage between security control module connector and body.

Connector & terminal / Specified voltage:
(B93) No. 1 — Body / 1 V, max.

2. CHECK DOOR LOCK/UNLOCK SWITCH.

Refer to 6-2 [W22B5] for inspection of door lock/unlock switch.

K: DIAGNOSTICS PROCEDURE FOR KEY CYLINDER LOCK/UNLOCK SWITCH AND TAMPER SWITCH SIGNAL

NOTE:

Key cylinder lock switch, key cylinder unlock switch and tamper switch are combined as a unit.

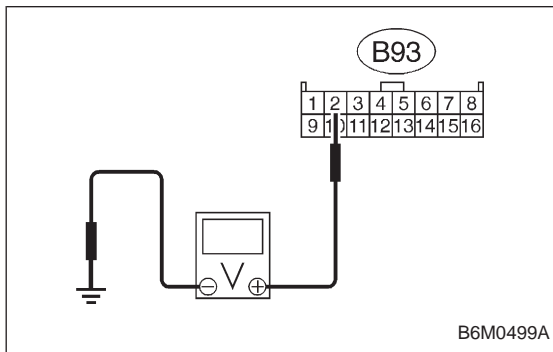
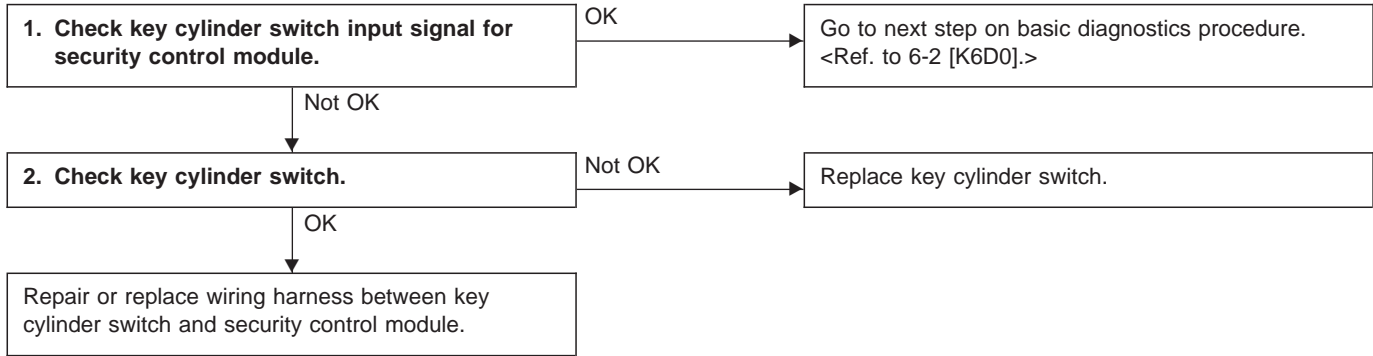

1. CHECK KEY CYLINDER SWITCH INPUT SIGNAL FOR SECURITY CONTROL MODULE.

- 1) Remove security control module without disconnecting connector.
- 2) Measure voltage between security control module connector and body while turning each key cylinder with ignition key.

Doors (RH and LH), and rear gate (WAGON)

Connector & terminal / Specified voltage:

(B93) No. 2 — Body / 1 V, max. (LOCK position) / 10 V, or more (other than LOCK position)

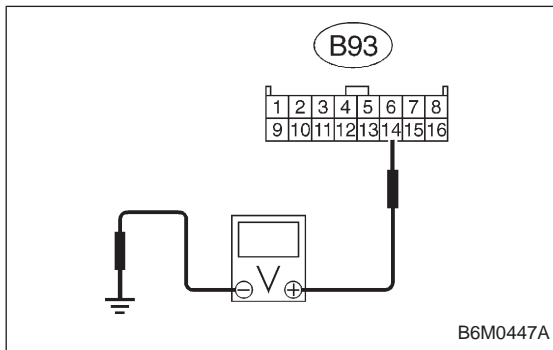

(B93) No. 14 — Body / 1 V, max. (UNLOCK position) / 10 V, or more (other than UNLOCK position)

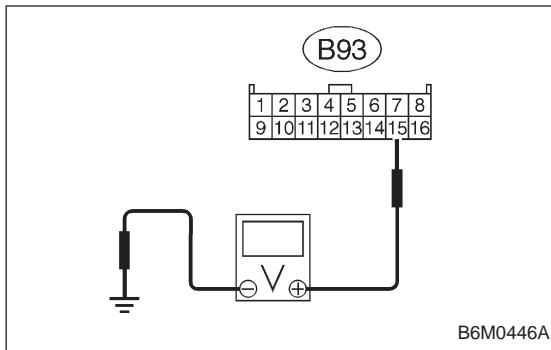
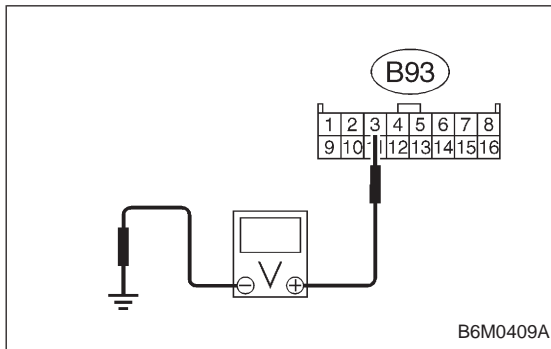
**Trunk lid (SEDAN)****Connector & terminal / Specified voltage:****(B93) No. 15 — Body / 1 V, max.****(UNLOCK position)****/ 10 V, or more (other than UNLOCK position)**

3) Measure voltage between security control module connector and body while removing/installing key cylinder switch from/to door outer handle.

Connector & terminal / Specified voltage:**(B93) No. 3 — Body / 10 V, or more****(Switch is installed.)****/ 1 V, max.****(Switch is removed.)****NOTE:**

For SEDAN vehicles, remove key cylinder switch from trunk lid key cylinder to perform the above inspection.

2. CHECK KEY CYLINDER SWITCH.

Refer to 6-2 [W22B4] for inspection of key cylinder lock/unlock switch and tamper switch.

L: DIAGNOSTICS PROCEDURE FOR STARTER INTERRUPT SIGNAL

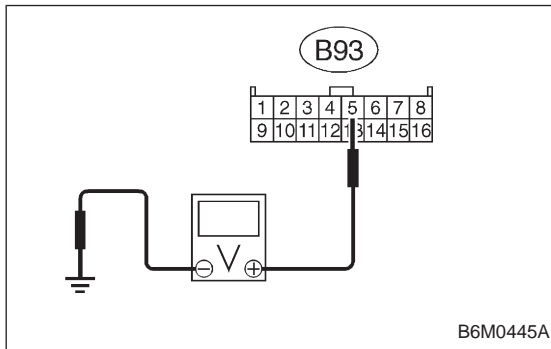
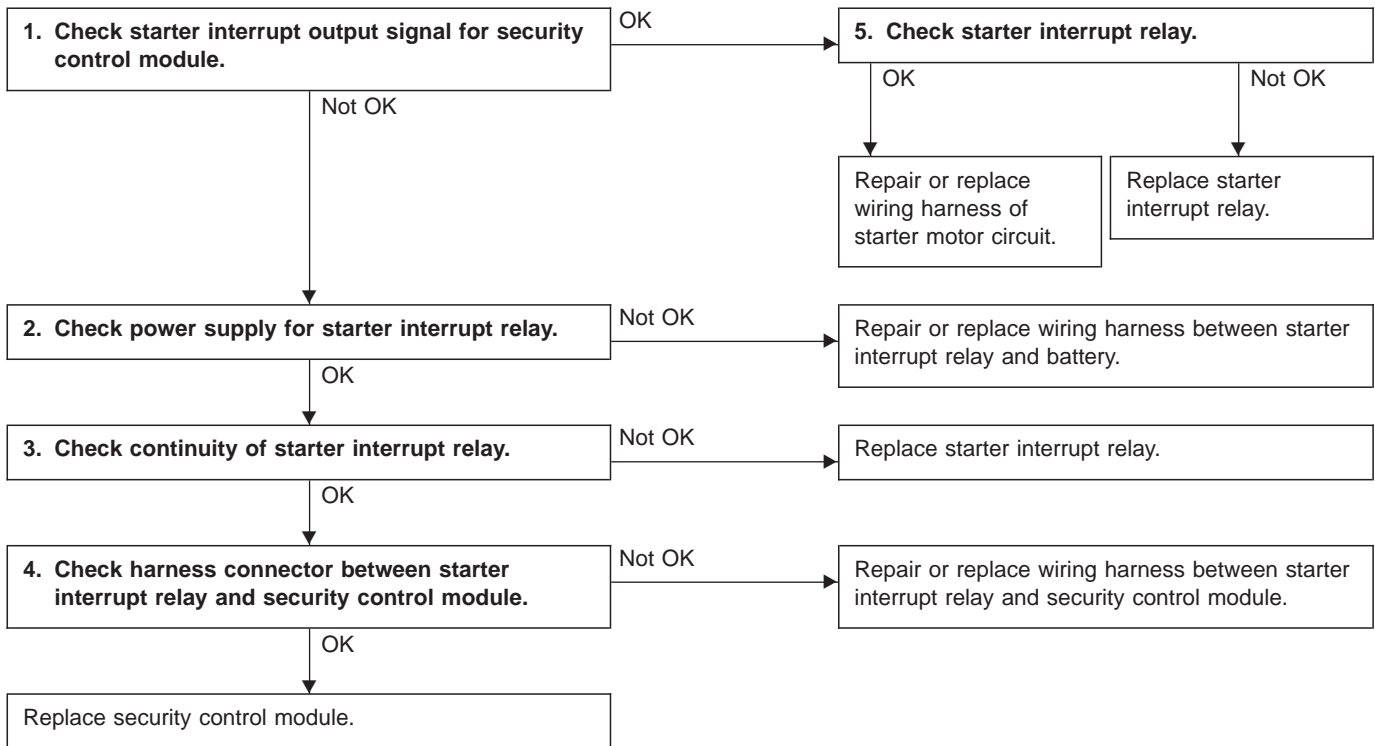

1. CHECK STARTER INTERRUPT OUTPUT SIGNAL FOR SECURITY CONTROL MODULE.

- 1) Remove security control module without disconnecting connector.
- 2) Measure voltage between security control module connector and body.

Connector & terminal / Specified voltage:
(B93) No. 5 — Body / 10 V, or more

- 3) Set security system in armed state.
- 4) Open the door without ignition key to operate the security system (alarm state).
- 5) Measure voltage between security control module and body during alarm state.

Connector & terminal / Specified voltage:
(B93) No. 5 — Body / 1 V, max.

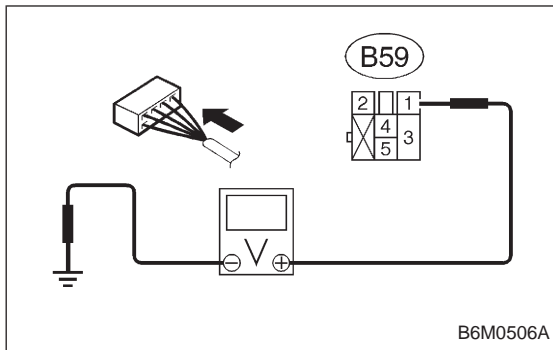

2. CHECK POWER SUPPLY FOR STARTER INTERRUPT RELAY.

- 1) Remove starter interrupt relay without disconnecting connector.
- 2) Measure voltage between starter interrupt relay connector and body.

Connector & terminal / Specified voltage:
(B59) No. 1 — Body / 10 V, or more

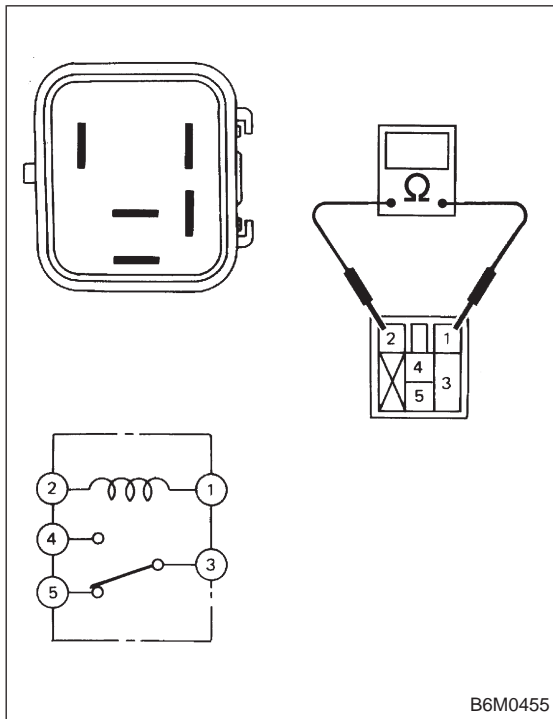

3. CHECK CONTINUITY OF STARTER INTERRUPT RELAY.

- 1) Remove starter interrupt relay.
- 2) Check continuity between terminals No. 1 and No. 2 of starter interrupt relay.

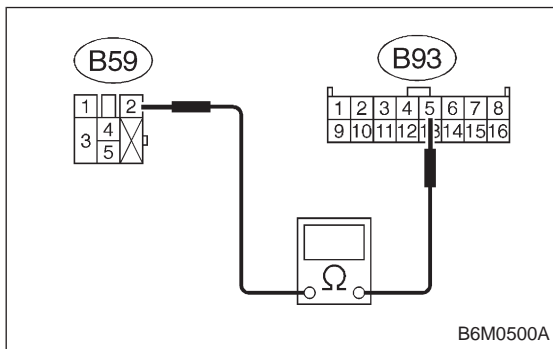

4. CHECK HARNESS CONNECTOR BETWEEN STARTER INTERRUPT RELAY AND SECURITY CONTROL MODULE.

- 1) Disconnect connectors of starter interrupt relay and security control module.
- 2) Measure resistance of harness connector between starter interrupt relay and security control module.

Connector & terminal / Specified resistance:
(B59) No. 2 — (B93) No. 5 / 10 Ω , max.

5. CHECK STARTER INTERRUPT RELAY.

Refer to 6-2 [W22B1] for inspection of starter interrupt relay.

M: DIAGNOSTICS PROCEDURE FOR HORN ALARM SIGNAL

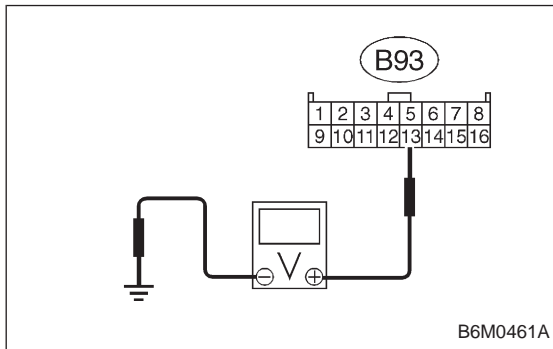
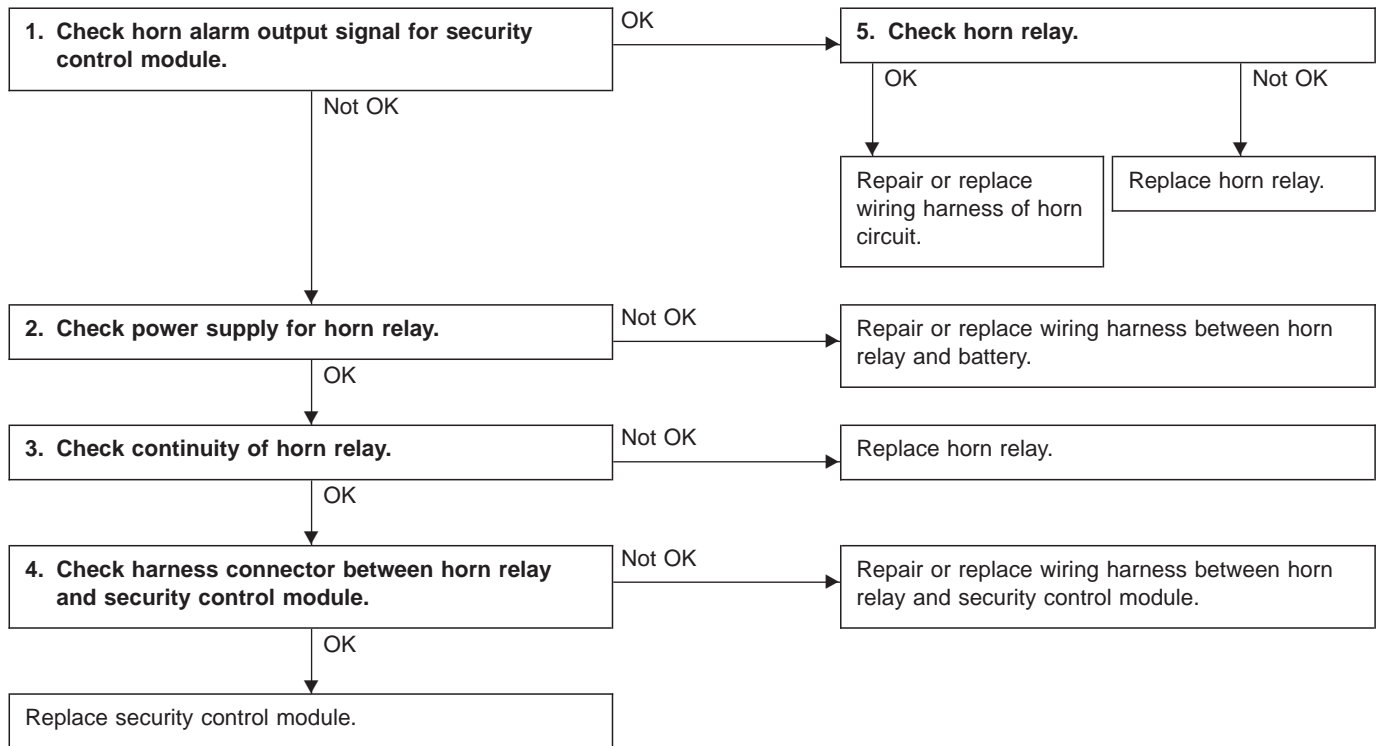

1. CHECK HORN ALARM OUTPUT SIGNAL FOR SECURITY CONTROL MODULE.

- 1) Remove security control module without disconnecting connector.
- 2) Measure voltage between security control module connector and body.

Connector & terminal / Specified voltage:
(B93) No. 13 — Body / 10 V, or more

- 3) Set security system in armed state.
- 4) Open the door without ignition key to operate the security system (alarm state).
- 5) Measure voltage between security control module and body during alarm state.

Connector & terminal / Specified voltage:
(B93) No. 13 — Body / repeats 1 V, max. (0.2 sec.) and 10 V, or more (0.6 sec.) intervals

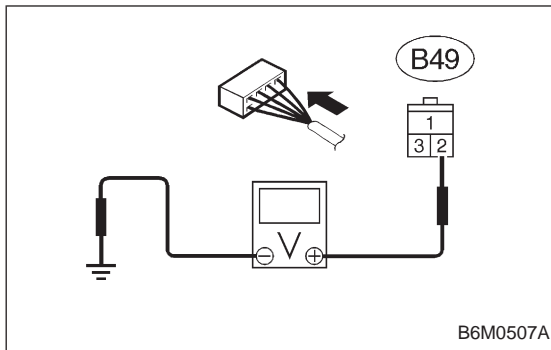
**2. CHECK POWER SUPPLY FOR HORN RELAY.**

- 1) Check fuse No. 12.
- 2) Remove horn relay without disconnecting connector.
- 3) Measure voltage between horn relay connector and body.

Connector & terminal / Specified voltage:
(B49) No. 2 — Body / 10 V, or more

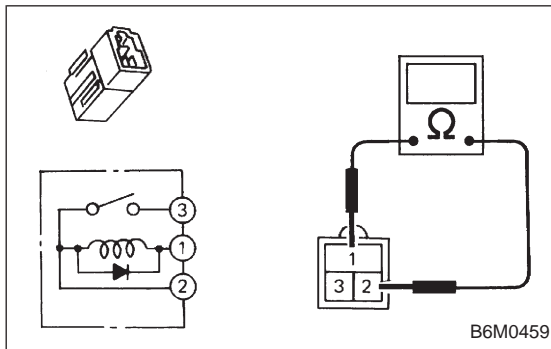
**3. CHECK CONTINUITY OF HORN RELAY.**

- 1) Remove horn relay.
- 2) Check continuity between terminals No. 1 and No. 2 of horn relay.

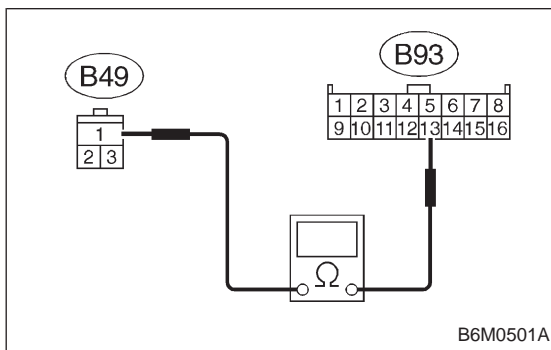
**4. CHECK HARNESS CONNECTOR BETWEEN HORN RELAY AND SECURITY CONTROL MODULE.**

- 1) Disconnect connectors of horn relay and security control module.
- 2) Measure resistance of harness connector between horn relay and security control module.

Connector & terminal / Specified resistance:
(B49) No. 1 — (B93) No. 13 / 10 Ω , max.

5. CHECK HORN RELAY.

Refer to 6-2 [W15B2] for inspection of horn relay.

N: DIAGNOSTICS PROCEDURE FOR HEADLIGHT ALARM SIGNAL

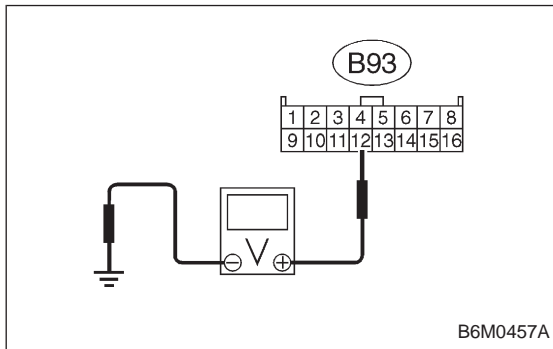
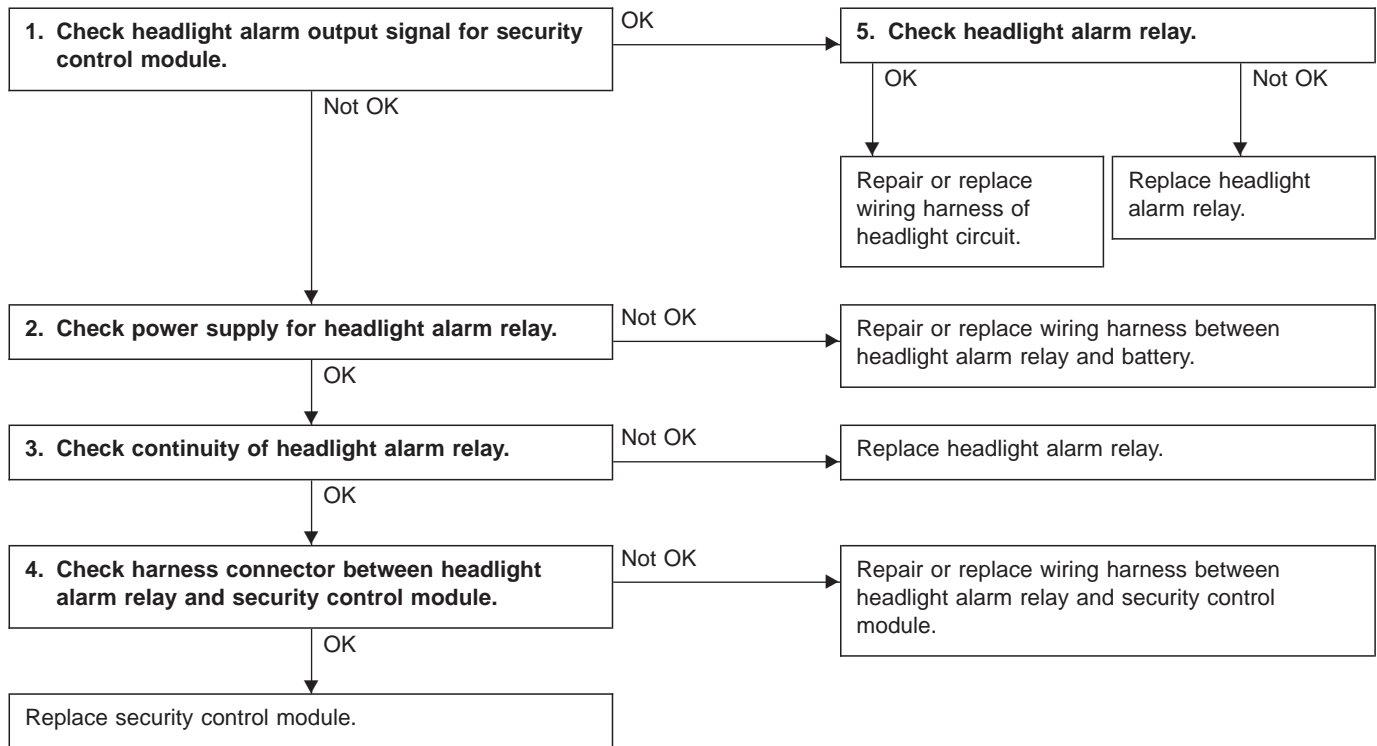

1. CHECK HEADLIGHT ALARM OUTPUT SIGNAL FOR SECURITY CONTROL MODULE.

- 1) Remove security control module without disconnecting connector.
- 2) Measure voltage between security control module connector and body.

Connector & terminal / Specified voltage:
(B93) No. 12 — Body / 10 V, or more

- 3) Set security system in armed state.
- 4) Open the door without ignition key to operate the security system (alarm state).
- 5) Measure voltage between security control module and body during alarm state.

Connector & terminal / Specified voltage:
(B93) No. 12 — Body / repeats 1 V, max. (0.2 sec.) and 10 V, or more (0.6 sec.) intervals

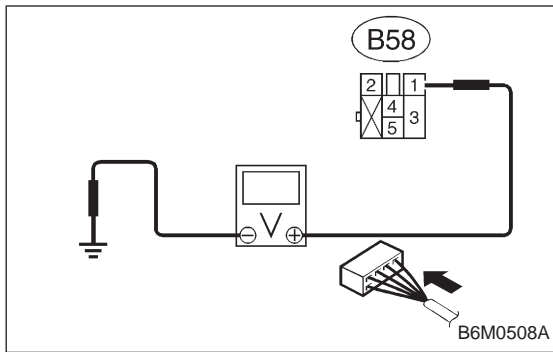

2. CHECK POWER SUPPLY FOR HEADLIGHT ALARM RELAY.

- 1) Remove headlight alarm relay without disconnecting connector.
- 2) Measure voltage between headlight alarm relay connector and body.

Connector & terminal / Specified voltage:
(B58) No. 1 — Body / 10 V, or more

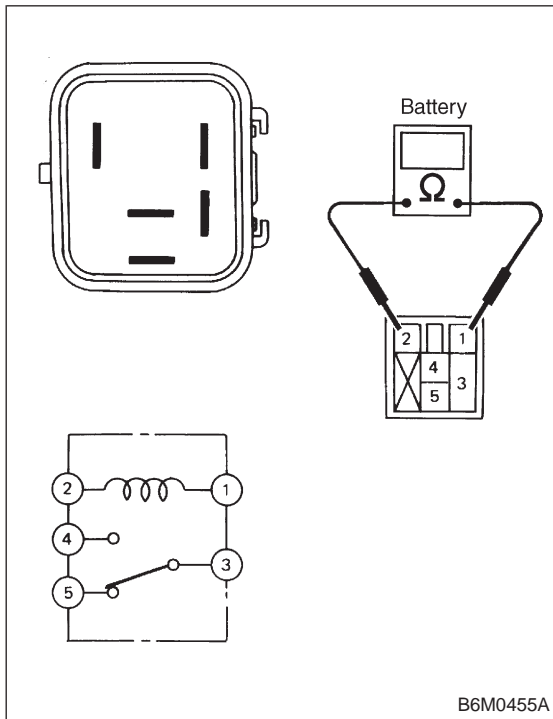

3. CHECK CONTINUITY OF HEADLIGHT ALARM RELAY.

- 1) Remove headlight alarm relay.
- 2) Check continuity between terminals No. 1 and No. 2 of headlight alarm relay.

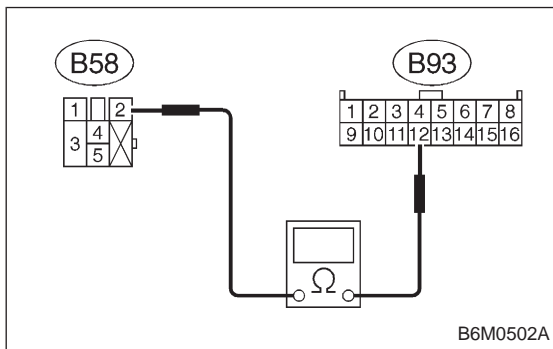

4. CHECK HARNESS CONNECTOR BETWEEN HEADLIGHT ALARM RELAY AND SECURITY CONTROL MODULE.

- 1) Disconnect connectors of headlight alarm relay and security control module.
- 2) Measure resistance of harness connector between headlight alarm relay and security control module.

Connector & terminal / Specified resistance:
(B58) No. 2 — (B93) No. 12 / 10 Ω, max.

5. CHECK HEADLIGHT ALARM RELAY.

Refer to 6-2 [W22B2] for inspection of headlight alarm relay.