

3. RELATED PARTS

- 1) Install valve rocker assembly.
<Ref. to 2-3 [W4E0].>

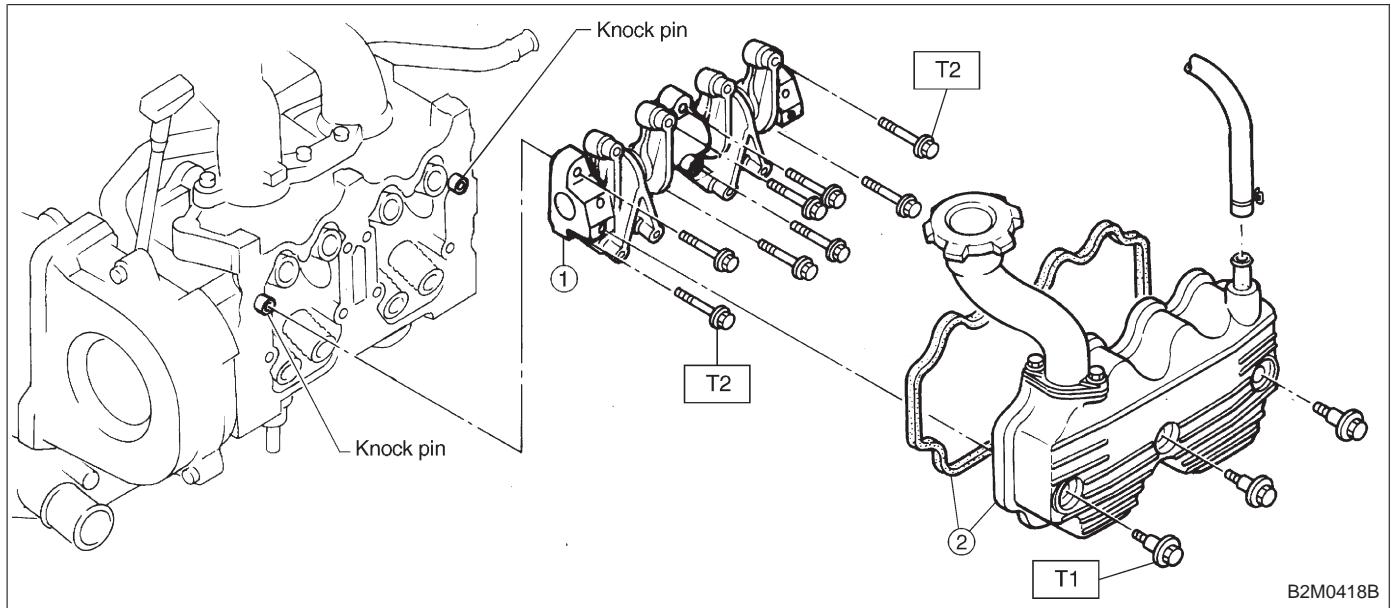

Tightening torque: N·m (kg·m, ft·lb)

T1: 5±1 (0.5±0.1, 3.6±0.7)

T2: 12±1 (1.2±0.1, 8.7±0.7)

- 2) Install timing belt, camshaft sprockets and related parts.
<Ref. to 2-3 [W3C0].>

6. Cylinder Head**A: REMOVAL****1. INTAKE MANIFOLD**

- 1) Release fuel pressure. <Ref. to 2-8 [W1A0].>
- 2) Drain engine coolant. <Ref. to 2-5 [W1A0].>
- 3) Remove intake manifold. <Ref. to 2-7 [W4A0].>
- 4) Remove engine coolant pipe.

2. CYLINDER HEAD

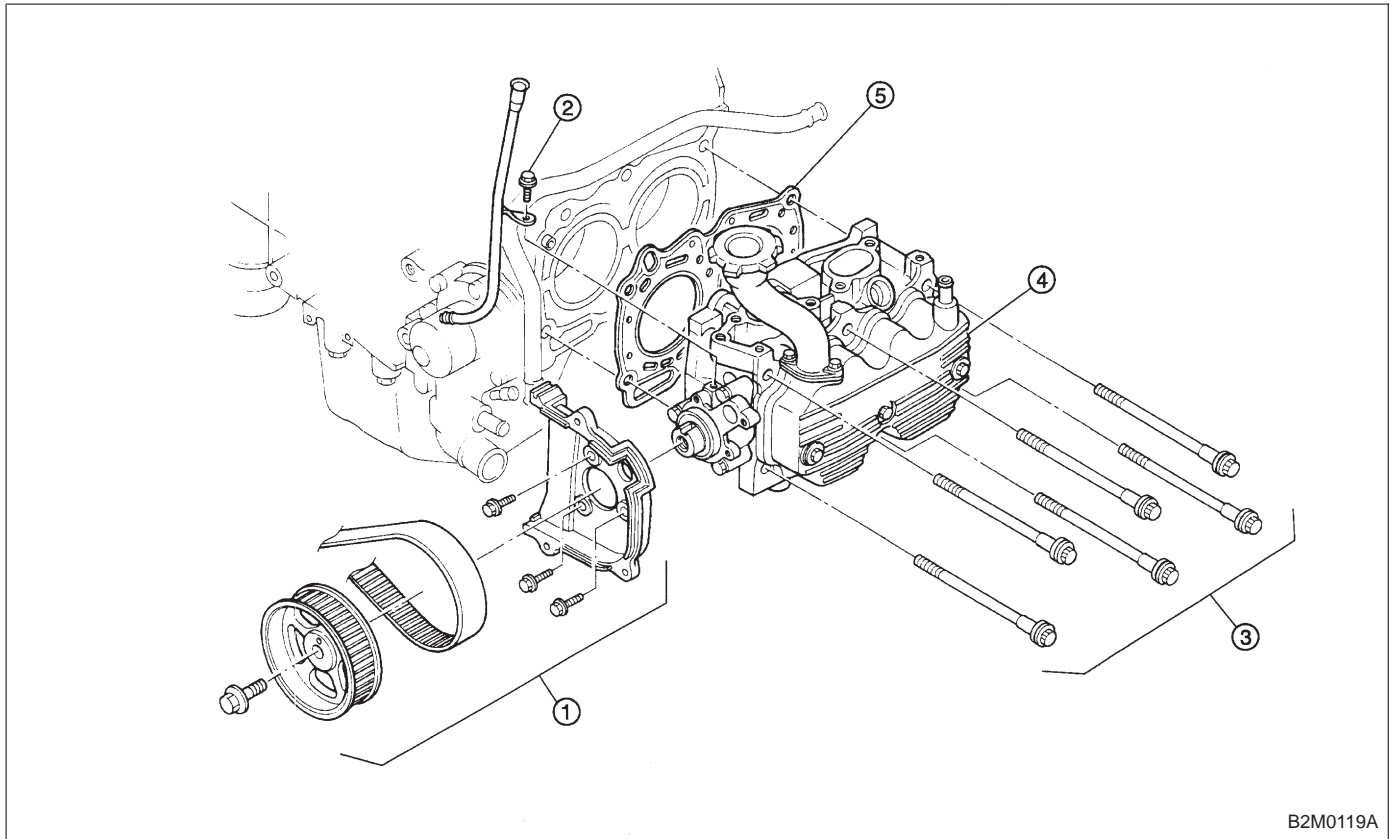

B2M0119A

1) Remove timing belt, camshaft sprocket and related parts.

<Ref. to 2-3 [W3A0].>

2) Remove oil level gauge guide attaching bolt (left hand only) and oil level gauge guide.

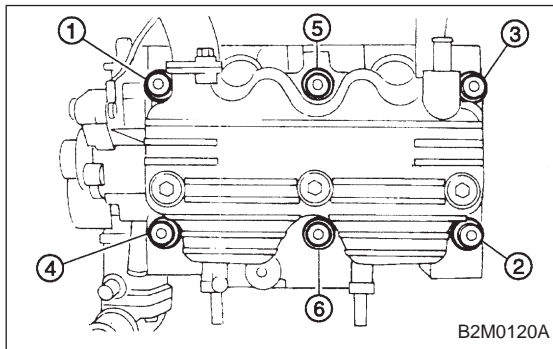

B2M0120A

3) Remove cylinder head bolts in numerical sequence shown in Figure.

CAUTION:

Leave bolts ① and ③ engaged by three or four threads to prevent cylinder head from falling.

4) While tapping cylinder head with a plastic hammer, separate it from cylinder block.

Remove bolts ① and ③ to remove cylinder head.

5) Remove cylinder head gasket.

CAUTION:

Do not scratch the mating surface of cylinder head and cylinder block.

6) Similarly, remove right side cylinder head.

B: DISASSEMBLY

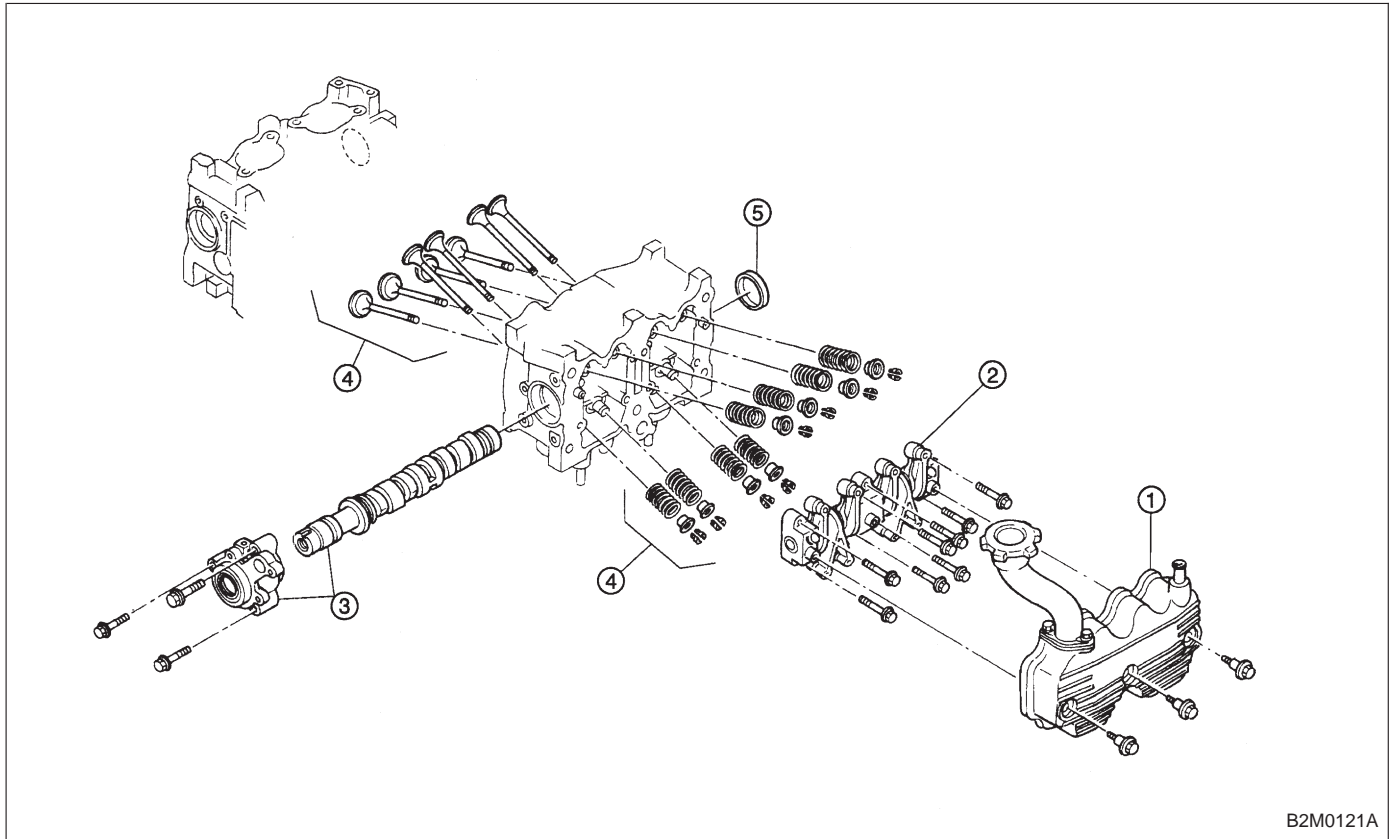

B2M0121A

- 1) Remove rocker cover.
- 2) Remove valve rocker assembly.
<Ref. to 2-3 [W4A0].>
- 3) Remove camshaft and support.
<Ref. to 2-3 [W5A0].>
- 4) Place cylinder head on ST.
ST 498267200 CYLINDER HEAD TABLE

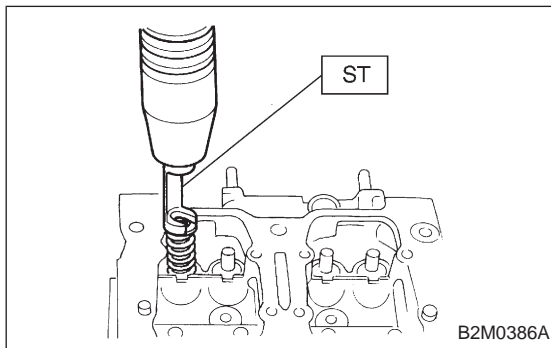

B2M0386A

- 5) Set ST on valve spring. Compress valve spring and remove the valve spring retainer key. Remove each valve and valve spring.

ST 499718000 VALVE SPRING REMOVER

CAUTION:

- Mark each valve to prevent confusion.
- Use extreme care not to damage the lips of the intake valve oil seals and exhaust valve oil seals.

- 6) Removal of plug (cylinder head LH)

CAUTION:**Do not remove plug unless necessary.**

C: INSPECTION

1. CYLINDER HEAD

1) Make sure that no crack or other damage exists. In addition to visual inspection, inspect important areas by means of red lead check.

Also make sure that gasket installing surface shows no trace of gas and water leaks.

2) Place cylinder head on ST.

ST 498267200 CYLINDER HEAD TABLE

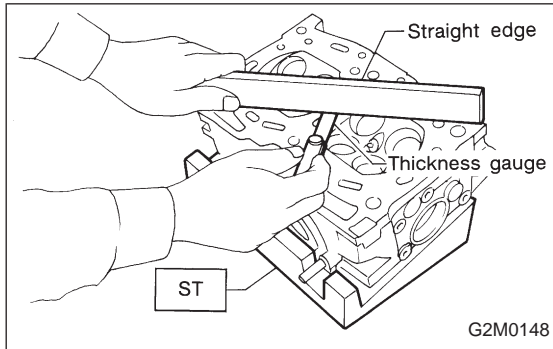

3) Measure the warping of the cylinder head surface that mates with crankcase by using a straight edge and thickness gauge.

If the warping exceeds 0.05 mm (0.0020 in), regrind the surface with a surface grinder.

Warping limit:

0.05 mm (0.0020 in)

Grinding limit:

0.1 mm (0.004 in)

Standard height of cylinder head:

98.3 mm (3.870 in)

CAUTION:

Uneven torque for the cylinder head bolts can cause warping. When reassembling, pay special attention to the torque so as to tighten evenly.

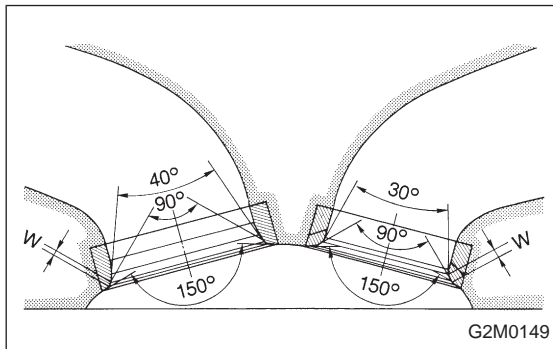

2. VALVE SEAT

Inspect intake and exhaust valve seats, and correct the contact surfaces with valve seat cutter if they are defective or when valve guides are replaced.

Valve seat width: W

Intake

Standard

0.7 mm (0.028 in)

Limit

1.4 mm (0.055 in)

Exhaust

Standard

1.4 mm (0.055 in)

Limit

1.8 mm (0.071 in)

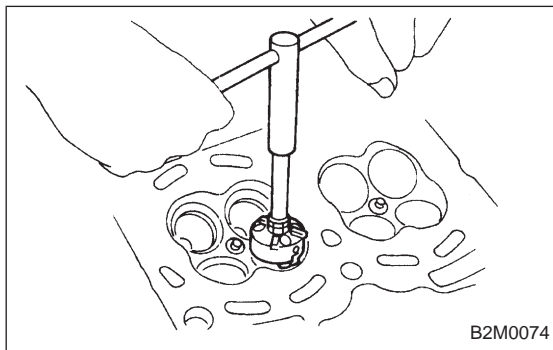

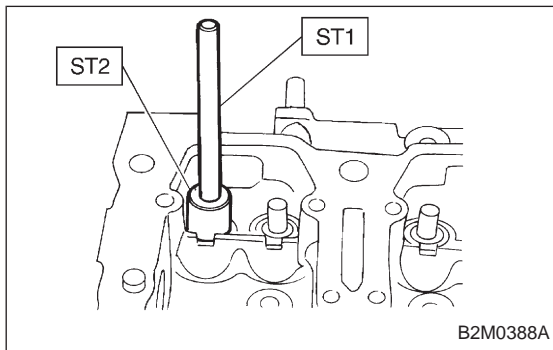
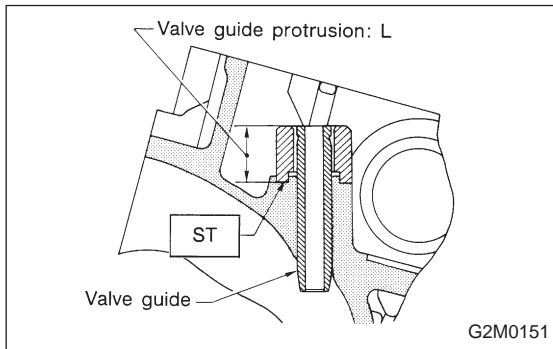
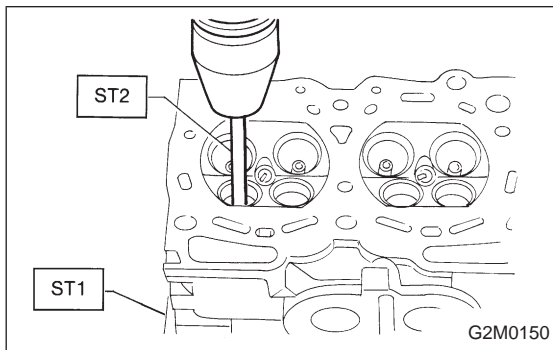
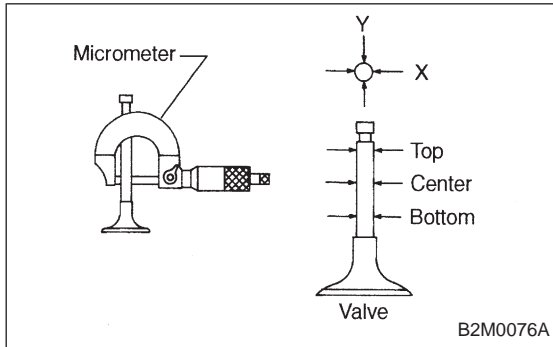
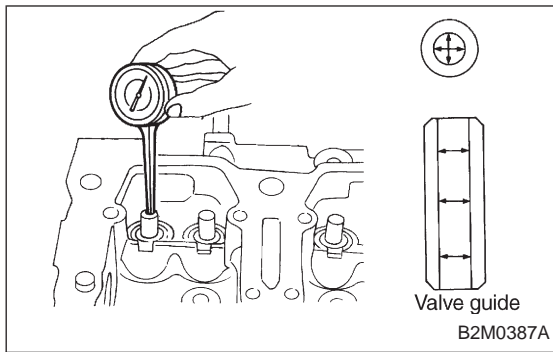

3. VALVE GUIDE

1) Check the clearance between valve guide and stem. The clearance can be checked by measuring the outside diameter of valve stem and the inside diameter of valve guide with outside and inside micrometers respectively.

Clearance between the valve guide and valve stem:

Standard

Intake

0.035 — 0.062 mm (0.0014 — 0.0024 in)

Exhaust

0.040 — 0.067 mm (0.0016 — 0.0026 in)

Limit

0.15 mm (0.0059 in)

Valve guide inner diameter:

6.000 — 6.012 mm (0.2362 — 0.2367 in)

Valve stem outer diameters:

Intake

5.950 — 5.965 mm (0.2343 — 0.2348 in)

Exhaust

5.945 — 5.960 mm (0.2341 — 0.2346 in)

2) If the clearance between valve guide and stem exceeds the specification, replace guide as follows:

(1) Place cylinder head on ST1 with the combustion chamber upward so that valve guides enter the holes in ST1.

(2) Insert ST2 into valve guide and press it down to remove valve guide.

ST1 498267200 CYLINDER HEAD TABLE

ST2 499767200 VALVE GUIDE REMOVER

(3) Turn cylinder head upside down and place ST as shown in the Figure.

ST 499767000 VALVE GUIDE ADJUSTER

(4) Before installing new oversize valve guide, make sure that neither scratches nor damages exist on the inside surface of the valve guide holes in cylinder head.

(5) Put new valve guide, coated with sufficient oil, in cylinder, and insert ST1 into valve guide. Press in until the valve guide upper end is flush with the upper surface of ST2.

ST1 499767200 VALVE GUIDE REMOVER

ST2 499767000 VALVE GUIDE ADJUSTER

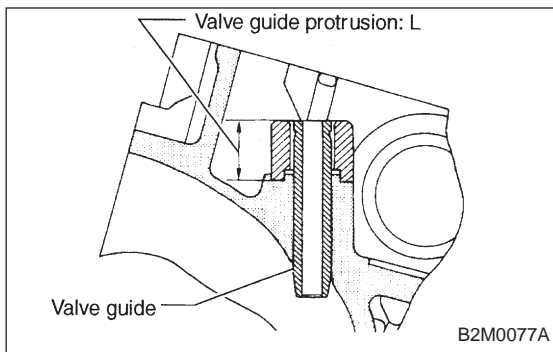

(6) Check the valve guide protrusion.

Valve guide protrusion: L
17.5 — 18.0 mm (0.689 — 0.709 in)

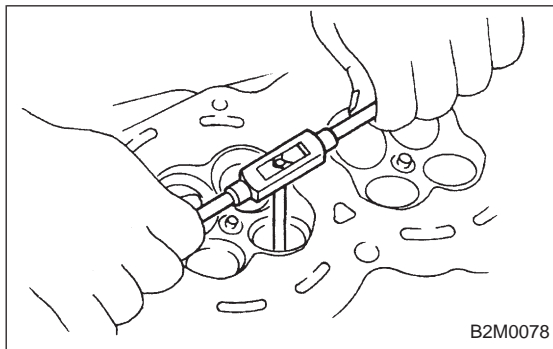

(7) Ream the inside of valve guide with ST. Gently rotate the reamer clockwise while pressing it lightly into valve guide, and return it also rotating clockwise. After reaming, clean valve guide to remove chips.

ST 499767400 VALVE GUIDE REAMER

CAUTION:

- Apply engine oil to the reamer when reaming.
- If the inner surface of the valve guide is torn, the edge of the reamer should be slightly ground with an oil stone.
- If the inner surface of the valve guide becomes lustrous and the reamer does not chips, use a new reamer or remedy the reamer.

(8) Recheck the contact condition between valve and valve seat after replacing valve guide.

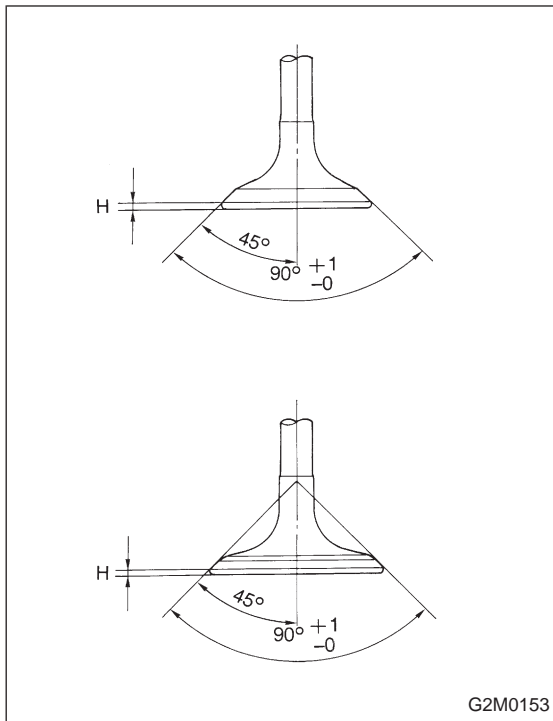

G2M0153

4. INTAKE AND EXHAUST VALVE

1) Inspect the flange and stem of valve, and replace if damaged, worn, or deformed, or if “H” is less than the specified limit.

H:

Intake

Standard

1.0 mm (0.039 in)

Limit

0.8 mm (0.031 in)

Exhaust

Standard

1.2 mm (0.047 in)

Limit

0.8 mm (0.031 in)

Valve overall length:

Intake

101.0 mm (3.976 in)

Exhaust

101.2 mm (3.984 in)

2) Put a small amount of grinding compound on the seat surface and lap the valve and seat surface. Also refer to 2. VALVE SEAT 2-3 [W6C2] at this time. Install a new intake valve oil seal after lapping.

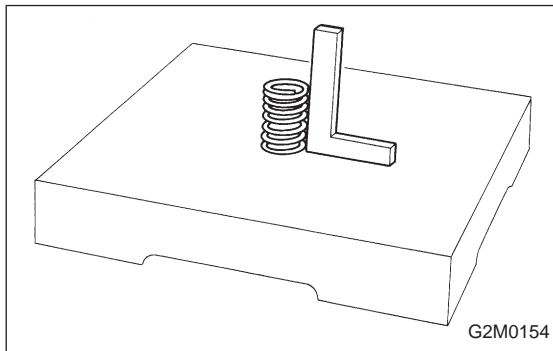

G2M0154

5. VALVE SPRINGS

1) Check valve springs for damage, free length, and tension. Replace valve spring if it is not to the specifications presented below.

2) To measure the squareness of the valve spring, stand the spring on a surface plate and measure its deflection at the top using a try square.

Free length	44.05 mm (1.7342 in)
Squareness	2.5°, 1.9 mm (0.075 in)
Tension/spring height	174.6 — 200.1 N (17.8 — 20.4 kg, 39.2 — 45.0 lb)/ 36.0 mm (1.417 in)
	405.0 — 458.0 N (41.3 — 46.7 kg, 91.1 — 103.0 lb)/ 28.2 mm (1.110 in)

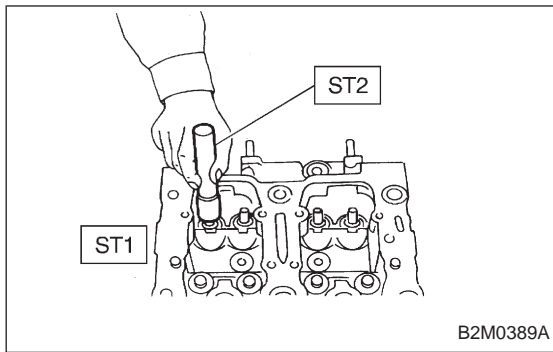

6. INTAKE AND EXHAUST VALVE OIL SEAL

Replace oil seal with new one, if lip is damaged or spring out of place, or when the surfaces of intake valve and valve seat are reconditioned or intake valve guide is replaced.

- 1) Place cylinder head on ST1.
- 2) Press-fit oil seal to the specified dimension indicated in the Figure by using ST2.

ST1 498267200 CYLINDER HEAD TABLE

ST2 498857100 VALVE OIL SEAL GUIDE

CAUTION:

- Apply engine oil to oil seal before press-fitting.
- When press-fitting oil seal, do not use hammer or strike in.
- Differentiate between intake valve oil seal and exhaust valve oil seal by noting their difference in color.

Color of rubber part:

Intake [Black]

Exhaust [Brown]

Color of spring part:

Intake [White]

Exhaust [White]

D: ASSEMBLY

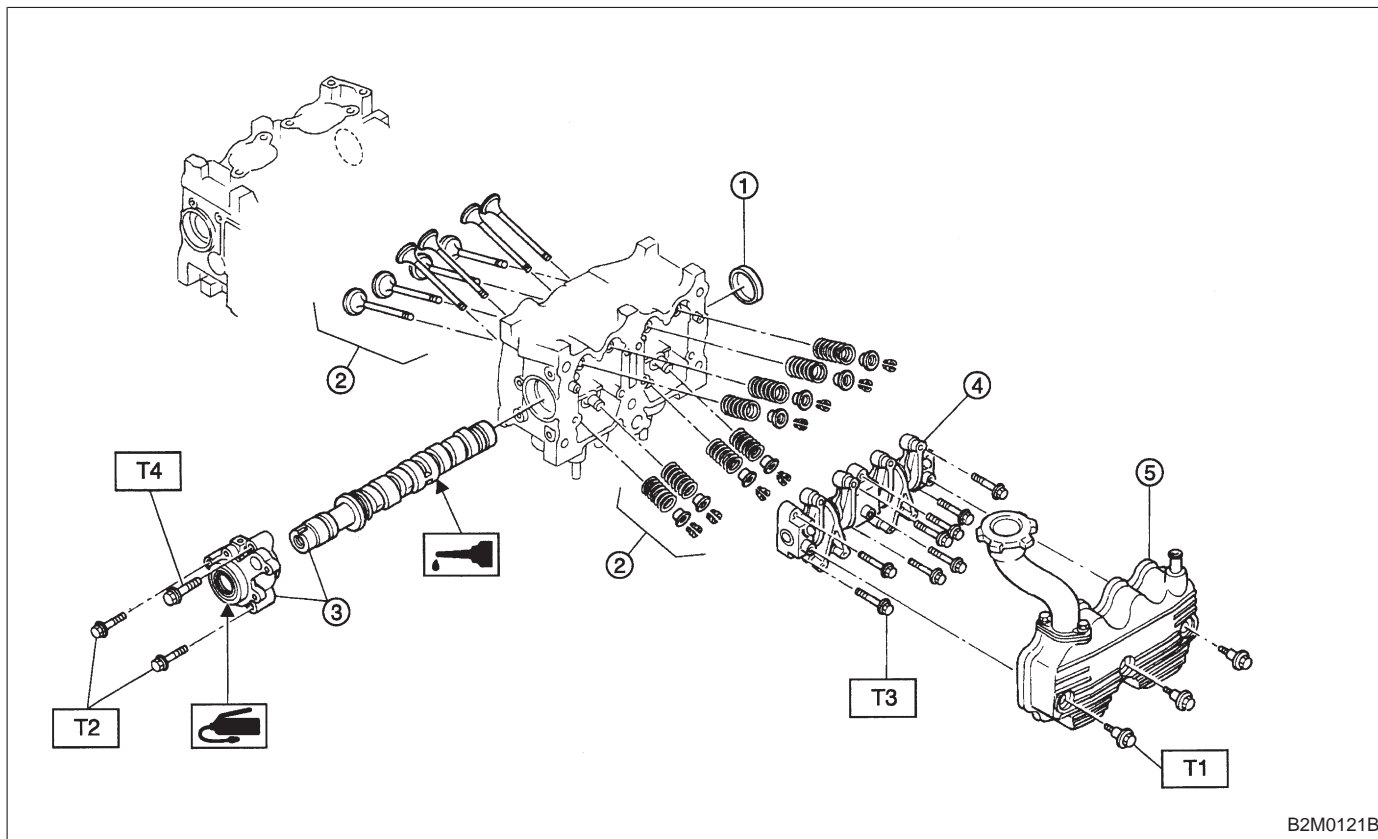

B2M0121B

Tightening torque: N·m (kg·m, ft·lb)

T1: 5±1 (0.5±0.1, 3.6±0.7)

T2: 10 (1.0, 7)

T3: 12±1 (1.2±0.1, 8.7±0.7)

T4: 16 (1.6, 12)

- 1) Install plug (cylinder head LH) by using ST.
ST 499587100 OIL SEAL INSTALLER
- 2) Installation of valve spring and valve
 - (1) Place cylinder head on ST.
ST 498267200 CYLINDER HEAD TABLE
 - (2) Coat stem of each valve with engine oil and insert valve into valve guide.

CAUTION:

When inserting valve into valve guide, use special care not to damage the oil seal lip.

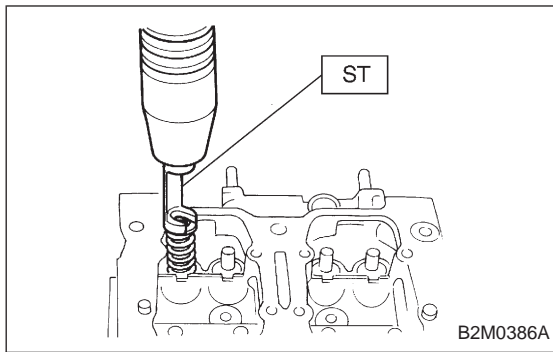

(3) Install valve spring and retainer.

CAUTION:

Be sure to install the valve springs with their painted facing towards the valve spring retainer.

(4) Set ST on valve spring.

ST 499718000 VALVE SPRING REMOVER

(5) Compress valve spring and fit valve spring retainer key.

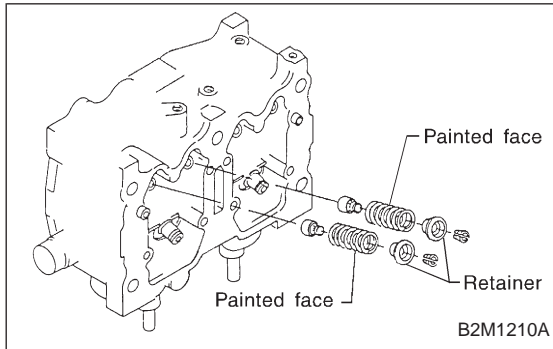

(6) After installing, tap valve spring retainers lightly with wooden hammer for better seating.

3) Install camshaft and support.

<Ref. to 2-3 [W5C0].>

4) Install valve rocker assembly.

<Ref. to 2-3 [W4E0].>

5) Install rocker cover.

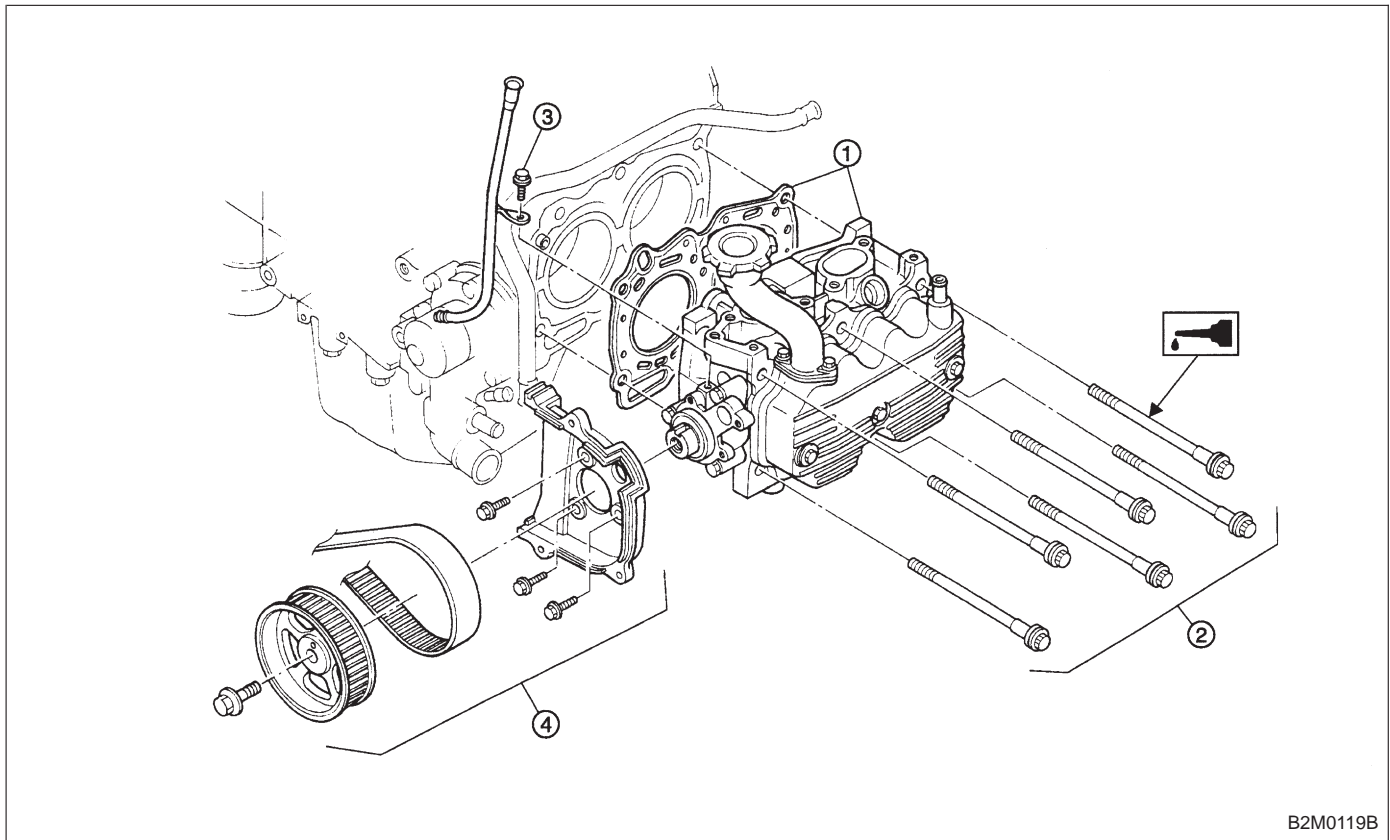
E: INSTALLATION**1. CYLINDER HEAD**

B2M0119B

1) Install cylinder head and gaskets on cylinder block.

CAUTION:

Use new cylinder head gaskets.

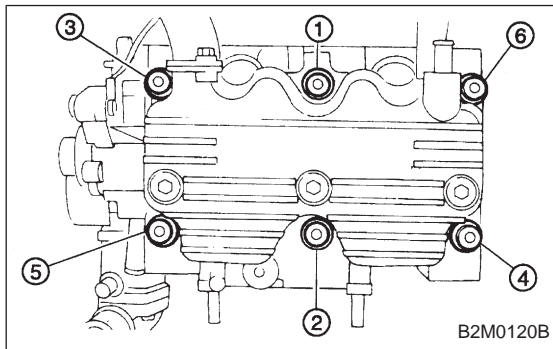

B2M0120B

2) Tighten cylinder head bolts.

(1) Apply a coat of engine oil to washers and bolt threads.

(2) Tighten all bolts to 29 N·m (3.0 kg-m, 22 ft-lb) in numerical sequence.

Then tighten all bolts to 69 N·m (7.0 kg-m, 51 ft-lb) in numerical sequence.

(3) Back off all bolts by 180° first; back them off by 180° again.

(4) Tighten bolts ① and ② to 34 N·m (3.5 kg-m, 25 ft-lb).

(5) Tighten bolts ③, ④, ⑤ and ⑥ to 15 N·m (1.5 kg-m, 11 ft-lb).

(6) Tighten all bolts by 80 to 90° in numerical sequence.

CAUTION:

Do not tighten bolts more than 90°.

(7) Further tighten all bolts by 80 to 90° in numerical sequence.

CAUTION:

Ensure that the total “re-tightening angle” [steps (6) and (7) above] do not exceed 180°.

3) Install oil level gauge guide attaching bolt (left side only).

4) Install timing belt, camshaft sprocket and related parts.
<Ref. to 2-3 [W3C0].>

2. INTAKE MANIFOLD

CAUTION:

Use dry compressed air to remove foreign particles before installing each solenoid valve and sensor.

1) Install engine coolant pipe.

2) Install intake manifold. <Ref. to 2-7 [W4D0].>

3) Remove ENGINE STAND (ST).