

17. Fuel Pump Relay - 19. Knock Sensor

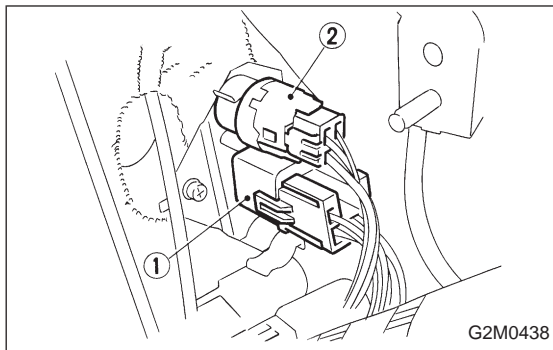

10) Installation is in the reverse order of removal.

- ① Main relay
- ② Fuel pump relay

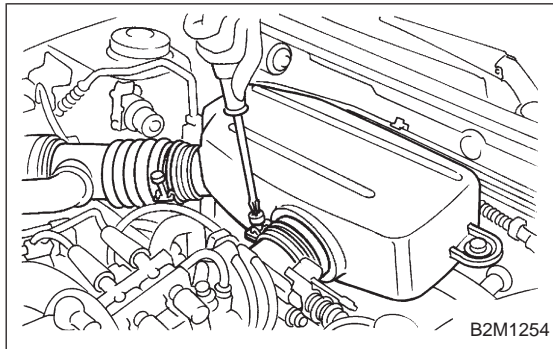

18. Air Intake Chamber

A: REMOVAL AND INSTALLATION

- 1) Loosen clamps which connect air intake chamber to throttle body and air intake duct.
- 2) Disconnect air hoses from air intake chamber.
- 3) Remove bolts which secure air intake chamber to stays.
- 4) Remove air intake chamber.
- 5) Installation is in the reverse order of removal.

Tightening torque:

$4.9 \pm 0.5 \text{ N} \cdot \text{m}$ ($0.5 \pm 0.05 \text{ kg} \cdot \text{m}$, $3.6 \pm 0.4 \text{ ft} \cdot \text{lb}$)

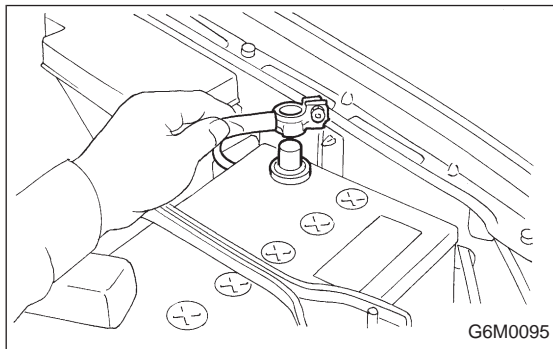

19. Knock Sensor

A: REMOVAL

1. 2200 cc MODEL

- 1) Disconnect battery ground cable from battery ground terminal.

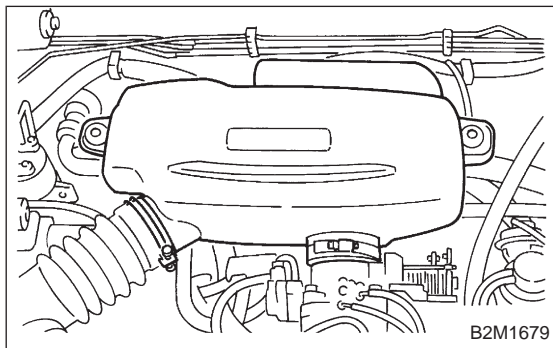

- 2) Remove air intake chamber.

<Ref. to 2-7 [W18A0].>