

**C: INSTALLATION**

**CAUTION:**

- If fuel hoses are damaged at the connecting portion, replace it with a new one.
- If clamps are badly damaged, replace with new ones.

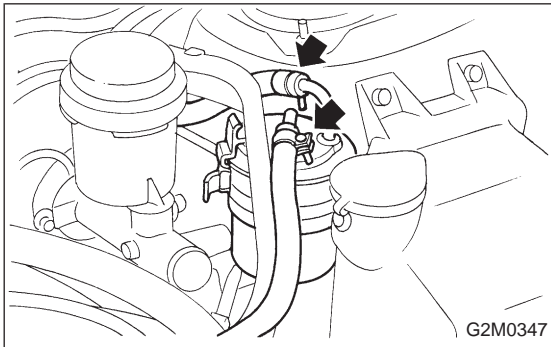

- 1) Installation is in the reverse order of removal.
- 2) Tighten hose clamp screws.

**Tightening torque:**

$1.0^{+0.5}_{-0}$  N·m ( $0.1^{+0.05}_{-0}$  kg·m,  $0.7^{+0.4}_{-0}$  ft·lb)

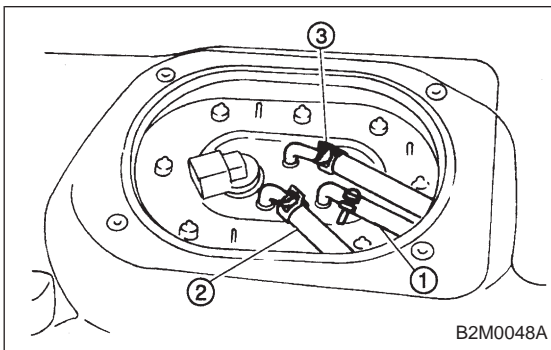

**6. Fuel Pump**

**A: REMOVAL**

- 1) Release fuel pressure. <Ref. to 2-8 [W1A0].>
- 2) Disconnect fuel delivery hose ① and return hose ②.
- 3) Disconnect jet pump hose ③. (AWD model)

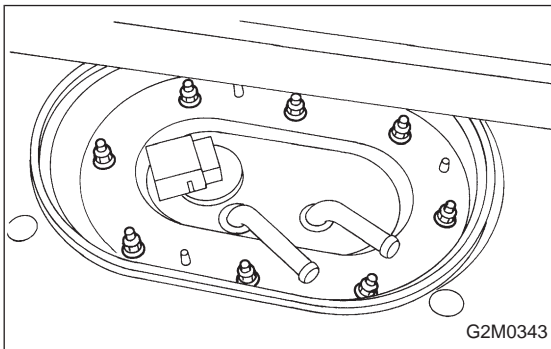

- 4) Remove nuts which install fuel pump assembly onto fuel tank.

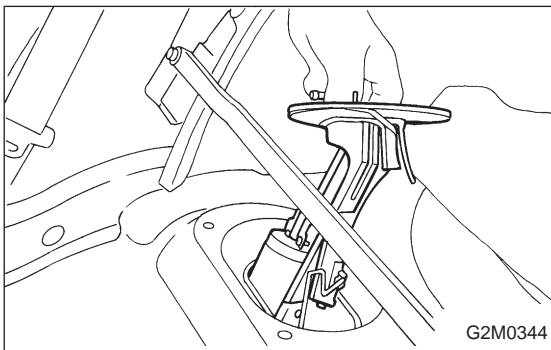

- 5) Take off fuel pump from fuel tank.

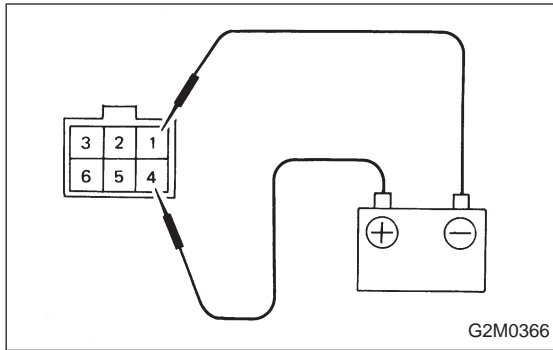

## B: INSPECTION

Connect lead harness to connector terminal of fuel pump, and apply battery power supply to check whether the pump operate.

### WARNING:

- Wipe off the fuel completely.
- Keep battery as far apart from fuel pump as possible.
- Be sure to turn the battery supply ON and OFF on the battery side.
- Do not run fuel pump for a long time under non-load condition.

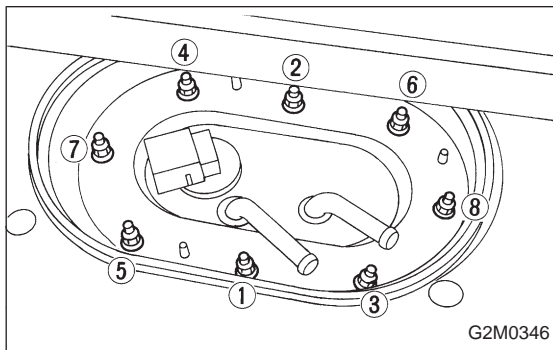

## C: INSTALLATION

Installation is in the reverse order of removal. Do the following:

- (1) Always use new gaskets.
- (2) Ensure sealing portion is free from fuel or foreign particles before installation.
- (3) Tighten nuts in numerical sequence shown in Figure to specified torque.

### Tightening torque:

$4.4 \pm 1.5 \text{ N}\cdot\text{m}$  ( $0.45 \pm 0.15 \text{ kg}\cdot\text{m}$ ,  $3.3 \pm 1.1 \text{ ft}\cdot\text{lb}$ )

## 7. Fuel Meter Unit

### A: REMOVAL

#### NOTE:

Fuel meter unit is built in fuel pump assembly.

- 1) Release fuel pressure. <Ref. to 2-8 [W1A0].>
- 2) Disconnect fuel delivery hose ① and return hose ②.
- 3) Disconnect jet pump hose ③. (AWD model)

