

7. Valve Clearance

A: INSPECTION

1. 2200 cc MODEL

CAUTION:

Inspection and adjustment of valve clearance should be performed while engine is cold.

- 1) Set the vehicle onto the lift.
- 2) Disconnect battery ground cable.
- 3) Remove timing belt cover (RH).
- 4) Remove rocker cover.
 - When inspecting #1 and #3 cylinders;
 - (1) Disconnect connector from mass air flow sensor.

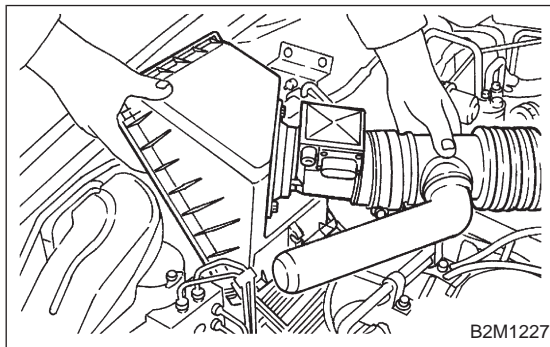
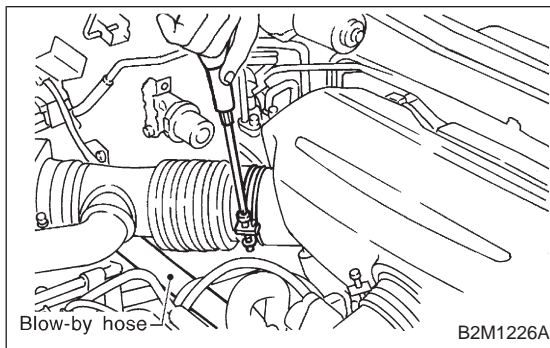
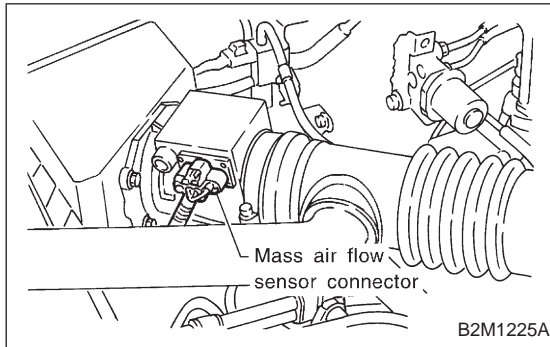

- (2) Loosen clamp which connects air intake duct to air intake chamber.
- (3) Remove the two clips from air cleaner upper cover.

CAUTION:

Before installing air cleaner upper cover, align hole(s) with protruding portions of air cleaner lower case, then secure upper cover.

- (4) Disconnect blow-by hose from air intake duct.
- (5) Remove air intake duct and air cleaner upper cover as a unit.
- (6) Remove air cleaner element.
- (7) Disconnect spark plug cords from spark plugs (#1 and #3 cylinders).
- (8) Remove under cover (RH).
- (9) Place suitable container under the vehicle.
- (10) Disconnect PCV hose from rocker cover (RH).
- (11) Remove bolts, then remove rocker cover (RH).

- When inspecting #2 and #4 cylinders;
 - (1) Disconnect battery cables, and then remove battery and battery carrier.
 - (2) Disconnect washer motor connectors.
 - (3) Disconnect rear window glass washer hose from washer motor, then plug connection with a suitable cap.
 - (4) Remove the two bolts which holds washer tank, then secure the tank away from working area.
 - (5) Disconnect spark plug cords from spark plugs (#2 and #4 cylinders).
 - (6) Remove under cover (LH).
 - (7) Place suitable container under the vehicle.
 - (8) Disconnect PCV hose from rocker cover (LH).
 - (9) Remove bolts, then remove rocker cover (LH).

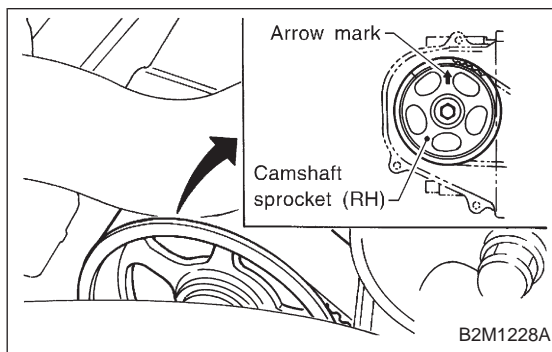

- 5) Set #1 cylinder piston to top dead center of compression stroke by rotating crankshaft pulley clockwise.

NOTE:

When arrow mark on camshaft sprocket (RH) comes exactly to the top, #1 cylinder piston is brought to the top dead center of compression stroke.

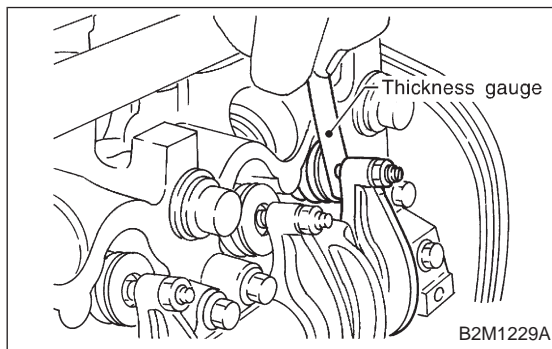

- 6) Measure #1 cylinder valve clearance by using thickness gauge.

CAUTION:

- Insert the thickness gauge in as horizontal a direction as possible with respect to the valve stem end face.
- Measure exhaust valve clearances while lifting-up the vehicle.

Valve clearance:

Intake: 0.20 ± 0.02 mm (0.0079 ± 0.0008 in)

Exhaust: 0.25 ± 0.02 mm (0.0098 ± 0.0008 in)

- 7) If necessary, adjust the valve clearance. <Ref. to 2-2 [07B1].>

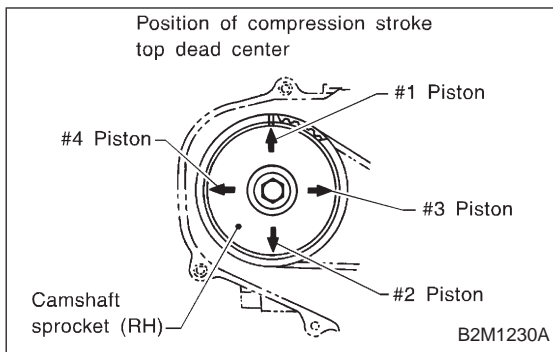

8) Similar to measurement procedures used for #1 cylinder, measure #2, #3 and #4 cylinder valve clearances.

NOTE:

- Be sure to set cylinder pistons to their respective top dead centers on compression stroke before measuring valve clearances.

- To set #3, #2 and #4 cylinder pistons to their top dead centers on compression stroke, turn crankshaft pulley clockwise 90° at a time starting with arrow mark on right-hand camshaft sprocket facing up.

9) After inspection, install the related parts in the reverse order of removal.

2. 2500 cc MODEL

CAUTION:

Inspection and adjustment of valve clearance should be performed while engine is cold.

- 1) Set the vehicle onto the lift.
- 2) Disconnect battery ground cable.
- 3) Remove canister.
- 4) Remove one bolt which secures timing belt cover (RH).
- 5) Lift-up the vehicle.
- 6) Remove under cover (RH).
- 7) Remove canister bracket.
- 8) Loosen remaining bolts which secure timing belt cover (RH), then remove belt cover.
- 9) Lower the vehicle.

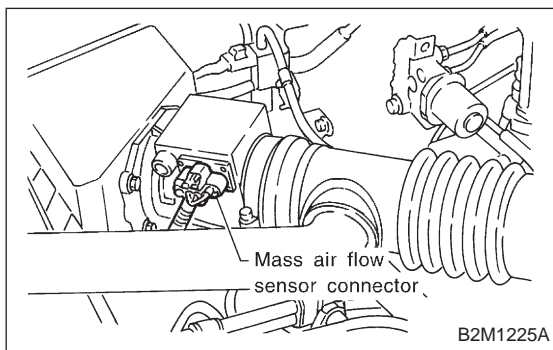

10) Remove rocker cover.

- When inspecting #1 and #3 cylinders;
 - (1) Disconnect connector from mass air flow sensor.

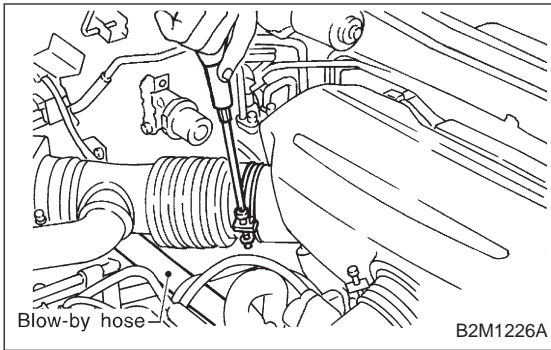

- (2) Loosen clamp which connects air intake duct to air intake chamber.
- (3) Remove the two clips from air cleaner upper cover.

CAUTION:

Before installing air cleaner upper cover, align hole(s) with protruding portions of air cleaner lower case, then secure upper cover.

- (4) Disconnect blow-by hose from air intake duct.

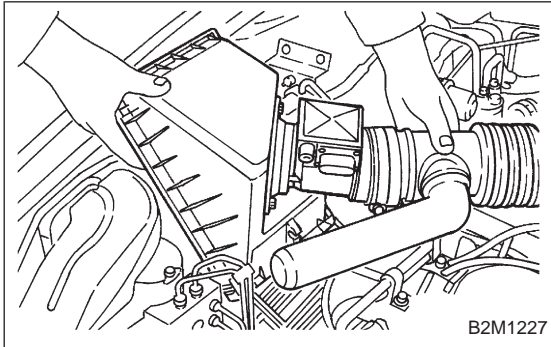

- (5) Remove air intake duct and air cleaner upper cover as a unit.
- (6) Remove air cleaner element.

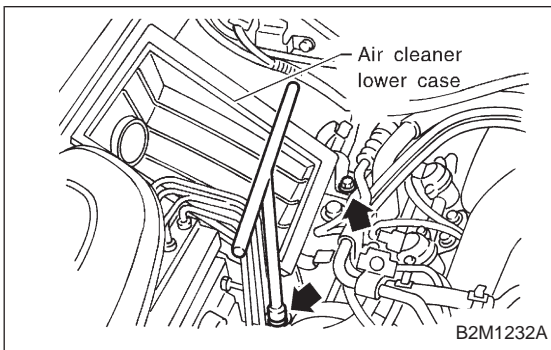

- (7) Remove air cleaner lower case.

- (8) Disconnect spark plug cords from spark plugs (#1 and #3 cylinders).
- (9) Place suitable container under the vehicle.
- (10) Disconnect PCV hose from rocker cover (RH).
- (11) Remove bolts, then remove rocker cover (RH).

- When inspecting # 2 and #4 cylinders;

- (1) Disconnect battery cables, and then remove battery and battery carrier.
- (2) Disconnect washer motor connectors.
- (3) Disconnect washer hoses from washer motors, then plug connections with suitable caps.
- (4) Remove washer tank.
- (5) Disconnect spark plug cords from spark plugs (#2 and #4 cylinders).
- (6) Remove under cover (LH).
- (7) Place suitable container under the vehicle.
- (8) Disconnect PCV hose from rocker cover (LH).
- (9) Remove bolts, then remove rocker cover (LH).

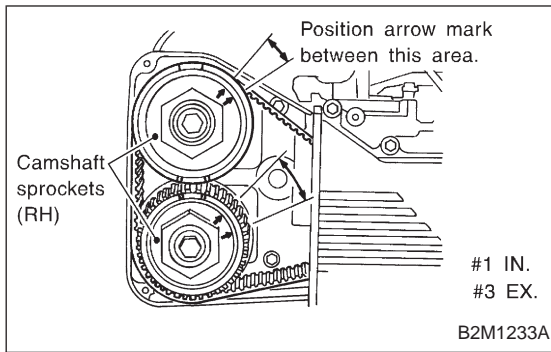

- 11) Turn crankshaft pulley clockwise until arrow mark on camshaft sprocket is set to position shown in figure.
- 12) Measure #1 cylinder intake valve and #3 cylinder exhaust valve clearances by using thickness gauge.

CAUTION:

- Insert the thickness gauge in as horizontal a direction as possible with respect to the shim.
- Measure exhaust valve clearances while lifting-up the vehicle.

Valve clearance:

Intake: 0.20 ± 0.02 mm (0.0079 ± 0.0008 in)

Exhaust: 0.25 ± 0.02 mm (0.0098 ± 0.0008 in)

- 13) If necessary, adjust the valve clearance. <Ref. to 2-2 [07B2].>

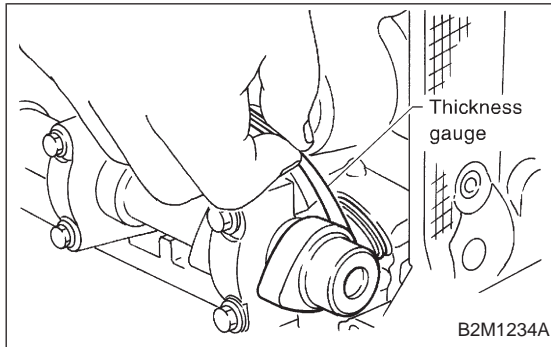

- 14) Further turn crankshaft pulley clockwise. Using the same procedures as in step 12) above, measure valve clearances.

- (1) Set arrow mark on camshaft sprocket to position shown in figure, and measure #2 cylinder exhaust valve and #3 cylinder intake valve clearances.

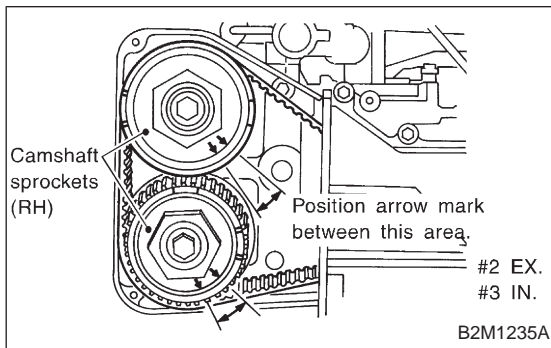

- (2) Set arrow mark on camshaft sprocket to position shown in figure, and measure #2 cylinder intake valve and #4 cylinder exhaust valve clearances.

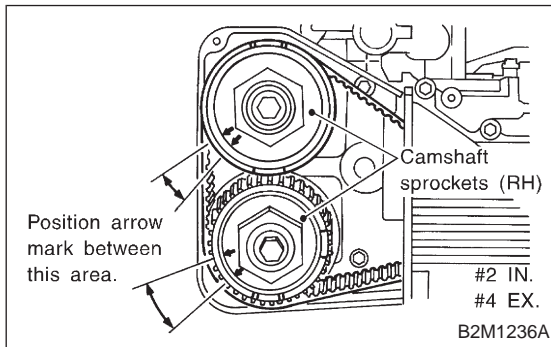

- (3) Set arrow mark on camshaft sprocket to position shown in figure, and measure #1 cylinder exhaust valve and #4 cylinder intake valve clearances.

- 15) After inspection, install the related parts in the reverse order of removal.

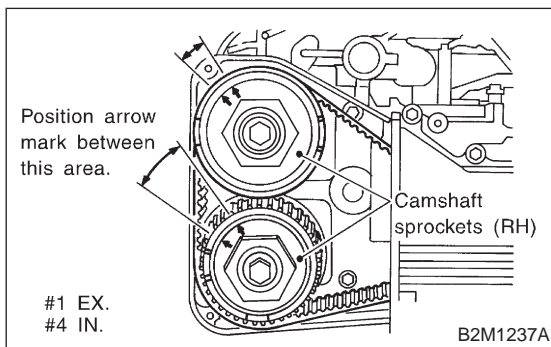

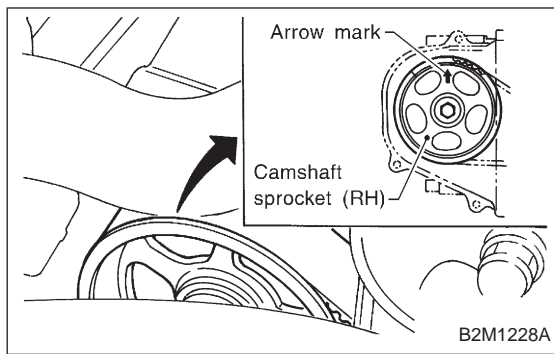

B: ADJUSTMENT

1. 2200 cc MODEL

CAUTION:

Adjustment of valve clearance should be performed while engine is cold.

1) Set #1 cylinder piston to top dead center of compression stroke by rotating crankshaft pulley clockwise.

NOTE:

When arrow mark on camshaft sprocket (RH) comes exactly to the top, #1 cylinder piston is brought to the top dead center of compression stroke.

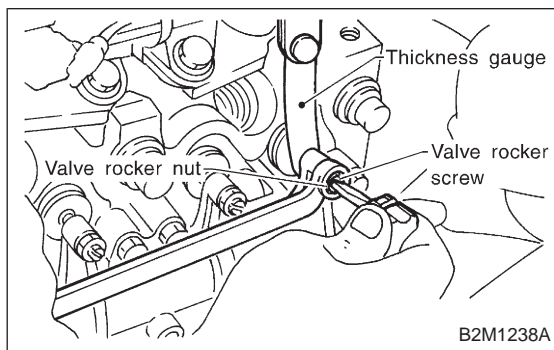

2) Adjust the #1 cylinder valve clearance.

- (1) Loosen the valve rocker nut and screw.
- (2) Place suitable thickness gauge.
- (3) While noting valve clearance, tighten valve rocker adjust screw.
- (4) When specified valve clearance is obtained, tighten valve rocker nut.

Tightening torque:

10 ± 1 N·m (1.0 ± 0.1 kg·m, 7.2 ± 0.7 ft·lb)

CAUTION:

- Insert the thickness gauge in as horizontal a direction as possible with respect to the valve stem end face.
- Adjust exhaust valve clearances while lifting-up the vehicle.

Valve clearance:

Intake: 0.20 ± 0.02 mm (0.0079 ± 0.0008 in)

Exhaust: 0.25 ± 0.02 mm (0.0098 ± 0.0008 in)

- 3) Ensure that valve clearances are within specifications.
- 4) Turn crankshaft two complete rotations until #1 cylinder piston is again set to top dead center on compression stroke.
- 5) Ensure that valve clearances are within specifications. If necessary, re-adjust valve clearances.

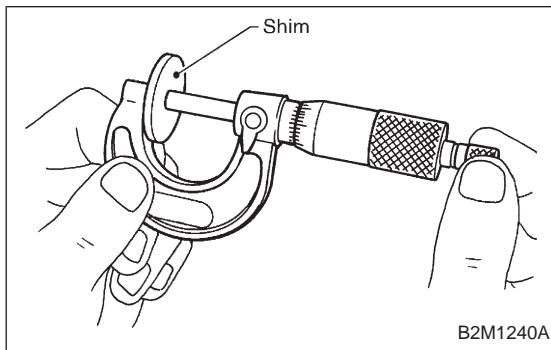
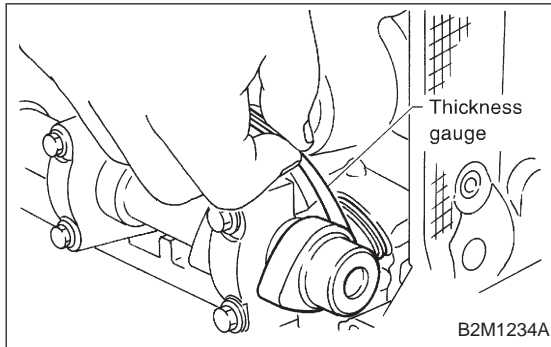
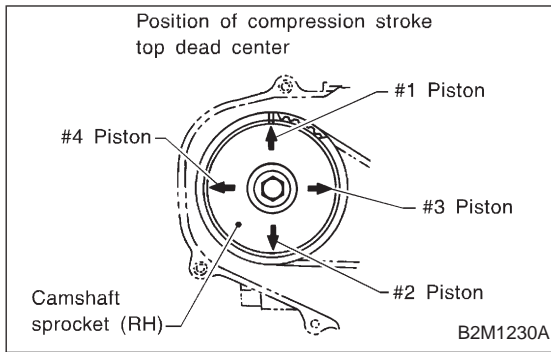

6) Similar to adjustment procedures used for #1 cylinder, adjust #2, #3 and #4 cylinder valve clearances.

NOTE:

- Be sure to set cylinder pistons to their respective top dead centers on compression stroke before adjusting valve clearances.
- To set #3, #2 and #4 cylinder pistons to their top dead centers on compression stroke, turn crankshaft pulley clockwise 90° at a time starting with arrow mark on right-hand camshaft sprocket facing up.

2. 2500 cc MODEL

CAUTION:

Adjustment of valve clearance should be performed while engine is cold.

1) Measure all valve clearances. <Ref. to 2-2 [07A2].>

NOTE:

- Record each valve clearance after it has been measured.
- 2) Remove timing belt, camshaft sprockets, and related parts. <Ref. to 2-3b [W2A0].>
 - 3) Remove camshaft. <Ref. to 2-3b [W3A0].>
 - 4) Remove shim from valve lifter.
 - 5) Measure thickness of shim with micrometer.

6) Select a shim of suitable thickness using measured valve clearance and shim thickness, using the following table.

Unit: mm

| |
|---|
| Intake valve: $S = (V + T) - 0.20$ Exhaust valve: $S = (V + T) - 0.25$ |
|---|

S: Shim thickness to be used

V: Measured valve clearance

T: Shim thickness required

| Part No. | Thickness mm (in) | Part No. | Thickness mm (in) |
|------------|-------------------|------------|-------------------|
| 13218AC290 | 2.33 (0.0917) | 13218AC480 | 2.52 (0.0992) |
| 13218AC300 | 2.34 (0.0921) | 13218AC490 | 2.53 (0.0996) |
| 13218AC310 | 2.35 (0.0925) | 13218AC500 | 2.54 (0.1000) |
| 13218AC320 | 2.36 (0.0929) | 13218AC510 | 2.55 (0.1004) |
| 13218AC330 | 2.37 (0.0933) | 13218AC520 | 2.56 (0.1008) |
| 13218AC340 | 2.38 (0.0937) | 13218AC530 | 2.57 (0.1012) |
| 13218AC350 | 2.39 (0.0941) | 13218AC540 | 2.58 (0.1016) |
| 13218AC360 | 2.40 (0.0945) | 13218AC550 | 2.59 (0.1020) |
| 13218AC370 | 2.41 (0.0949) | 13218AC560 | 2.60 (0.1024) |
| 13218AC380 | 2.42 (0.0953) | 13218AC570 | 2.61 (0.1028) |
| 13218AC390 | 2.43 (0.0957) | 13218AC580 | 2.62 (0.1031) |
| 13218AC400 | 2.44 (0.0961) | 13218AC590 | 2.63 (0.1035) |
| 13218AC410 | 2.45 (0.0965) | 13218AC600 | 2.64 (0.1039) |
| 13218AC420 | 2.46 (0.0969) | 13218AC610 | 2.65 (0.1043) |
| 13218AC430 | 2.47 (0.0972) | 13218AC620 | 2.66 (0.1047) |
| 13218AC440 | 2.48 (0.0976) | 13218AC630 | 2.67 (0.1051) |
| 13218AC450 | 2.49 (0.0980) | 13218AC640 | 2.68 (0.1055) |
| 13218AC460 | 2.50 (0.0984) | 13218AC650 | 2.69 (0.1059) |
| 13218AC470 | 2.51 (0.0988) | | |

7) Set suitable shim selected in step 6) to valve lifter.

8) Install camshaft. <Ref. to 2-3b [W3C0].>

9) Install camshaft sprockets, timing belt and related parts. <Ref. to 2-3b [W2C0].>

NOTE:

At this point, do not install rocker cover.

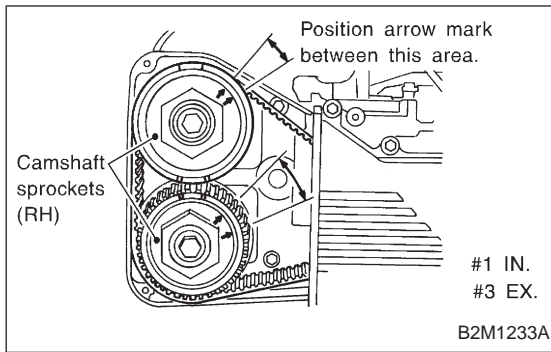

10) Turn crankshaft pulley clockwise until arrow mark on camshaft sprocket is set to position shown in figure.

11) Ensure that #1 cylinder intake valve and #3 cylinder exhaust valve are adjusted to specifications.

CAUTION:

- Insert the thickness gauge in as horizontal a direction as possible with respect to the shim.
- Adjust exhaust valve clearances while lifting-up the vehicle.

Valve clearance:

Intake: 0.20 ± 0.02 mm (0.0079 ± 0.0008 in)

Exhaust: 0.25 ± 0.02 mm (0.0098 ± 0.0008 in)

12) Turn crankshaft two complete rotations. Check again to ensure that #1 cylinder intake valve and #3 cylinder exhaust valve clearances are within specifications. If necessary, re-adjust valve clearances.

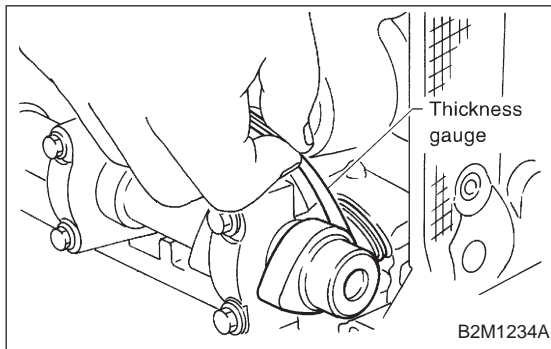

13) Further turn crankshaft pulley clockwise. Using the same procedures as in step 11) above, measure valve clearances.

(1) Set arrow mark on camshaft sprocket to position shown in figure, and check #2 cylinder exhaust valve and #3 cylinder intake valve clearances.

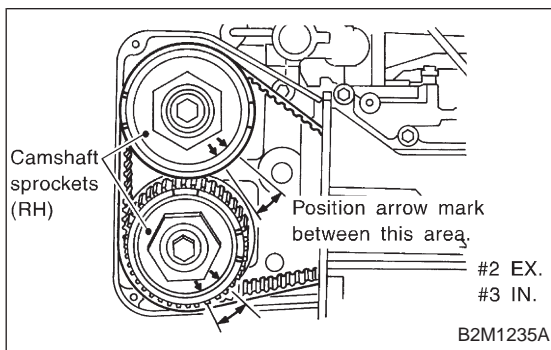

(2) Set arrow mark on camshaft sprocket to position shown in figure, and check #2 cylinder intake valve and #4 cylinder exhaust valve clearances.

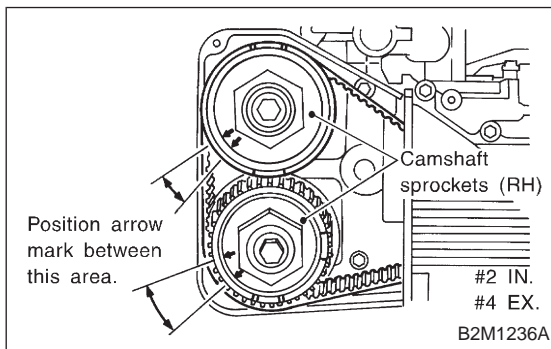

(3) Set arrow mark on camshaft sprocket to position shown in figure, and check #1 cylinder exhaust valve and #4 cylinder intake valve clearances.

