

## 6. Replacement of Rear DOJ and BJ Boots

### A: REMOVAL

- 1) Disconnect ground cable from battery.
- 2) Lift-up vehicle, and remove rear wheel cap and wheels.

#### NOTE:

Axle nut need not be removed.

- 3) Remove A.B.S. sensor clamps and parking brake cable bracket.
- 4) Disconnect stabilizer link from lateral link.
- 5) Remove bolts which secure lateral link assembly to rear housing.
- 6) Remove bolts which secure trailing link assembly to rear housing.
- 7) Remove crossmember reinforcement lower from cross-member (4 door model only).

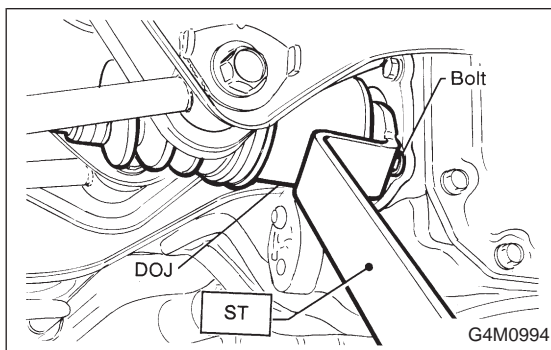

- 8) Remove DOJ from rear differential using ST.  
ST 28099PA100 DRIVE SHAFT REMOVER

#### NOTE:

The side spline shaft circlip comes out together with the shaft.

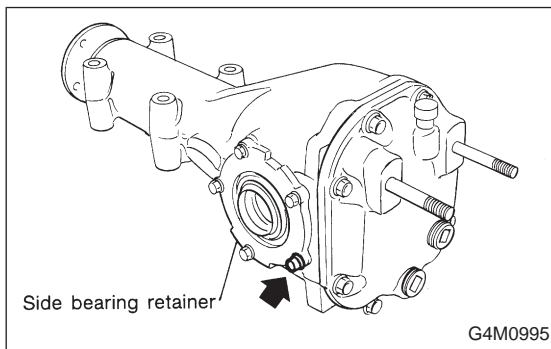

#### CAUTION:

Be careful not to damage side bearing retainer. Always use bolt as shown in figure, as supporting point for ST during removal.

ST 28099PA100 DRIVE SHAFT REMOVER

### B: INSTALLATION

- 1) Install DOJ and BJ boots to drive shaft.  
<Ref. to 4-2 [W4D0].>

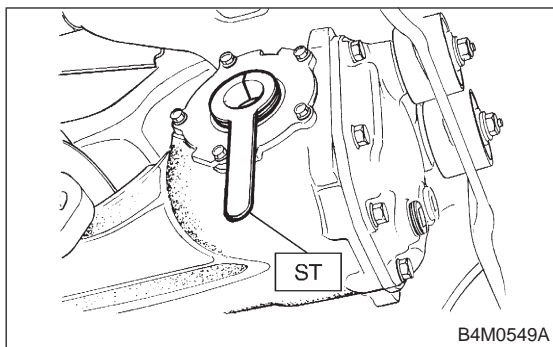

2) Using ST, install DOJ into differential.

ST 28099PA090 SIDE OIL SEAL PROTECTOR

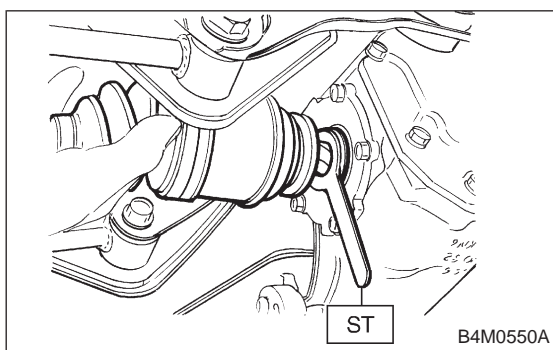

3) Insert DOJ spline end into bore of side oil seal, and remove ST.

**CAUTION:**

**Do not allow DOJ splines to damage side oil seal.**

ST 28099PA090 SIDE OIL SEAL PROTECTOR

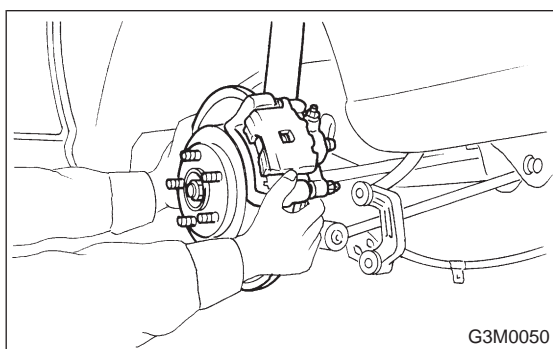

4) Align DOJ and differential splines.

5) Push housing to insert DOJ into differential.

**NOTE:**

Make sure DOJ is inserted properly.

**CAUTION:**

**Discard old self-locking nut. Replace with a new one.**

6) Connect rear housing assembly to trailing link assembly, and tighten self-locking nut.

7) Connect rear housing assembly to lateral link assembly, and tighten self-locking nut.

8) Connect stabilizer link to lateral link.

9) Install crossmember reinforcement lower to crossmember (4 door model only).

10) Install A.B.S. sensor clamps and parking brake cable bracket.