

---

## Important safety notice

---

- Providing appropriate service and repair is a matter of great importance in the serviceman's safety maintenance and safe operation, function and performance which the SUBARU vehicle possesses.
- In case the replacement of parts or replenishment of consumables is required, genuine SUBARU parts whose parts numbers are designated or their equivalents must be utilized.
- It must be made well known that the safety of the serviceman and the safe operation of the vehicle would be jeopardized if he used any service parts, consumables, special tools and work procedure manuals which are not approved or designated by SUBARU.

All right reserved. This book may not be reproduced or copied, in whole or in part, without the written permission of FUJI HEAVY INDUSTRIES LTD., TOKYO JAPAN.

SUBARU,  and  are trademarks of FUJI HEAVY INDUSTRIES LTD.

© Copyright 1996 FUJI HEAVY INDUSTRIES LTD.

# 1. General Description

## 1. HOW TO USE THIS MANUAL

The description of the electrical system is divided into the charging system, starting system, etc.

- 1) First, open to the necessary electrical system section and wiring diagram.
- 2) Next, open the foldout page of the electrical wiring diagram. By observing the electrical wiring harness' illustrations (front, instrument panel, etc.), the wiring diagram connector can be located.

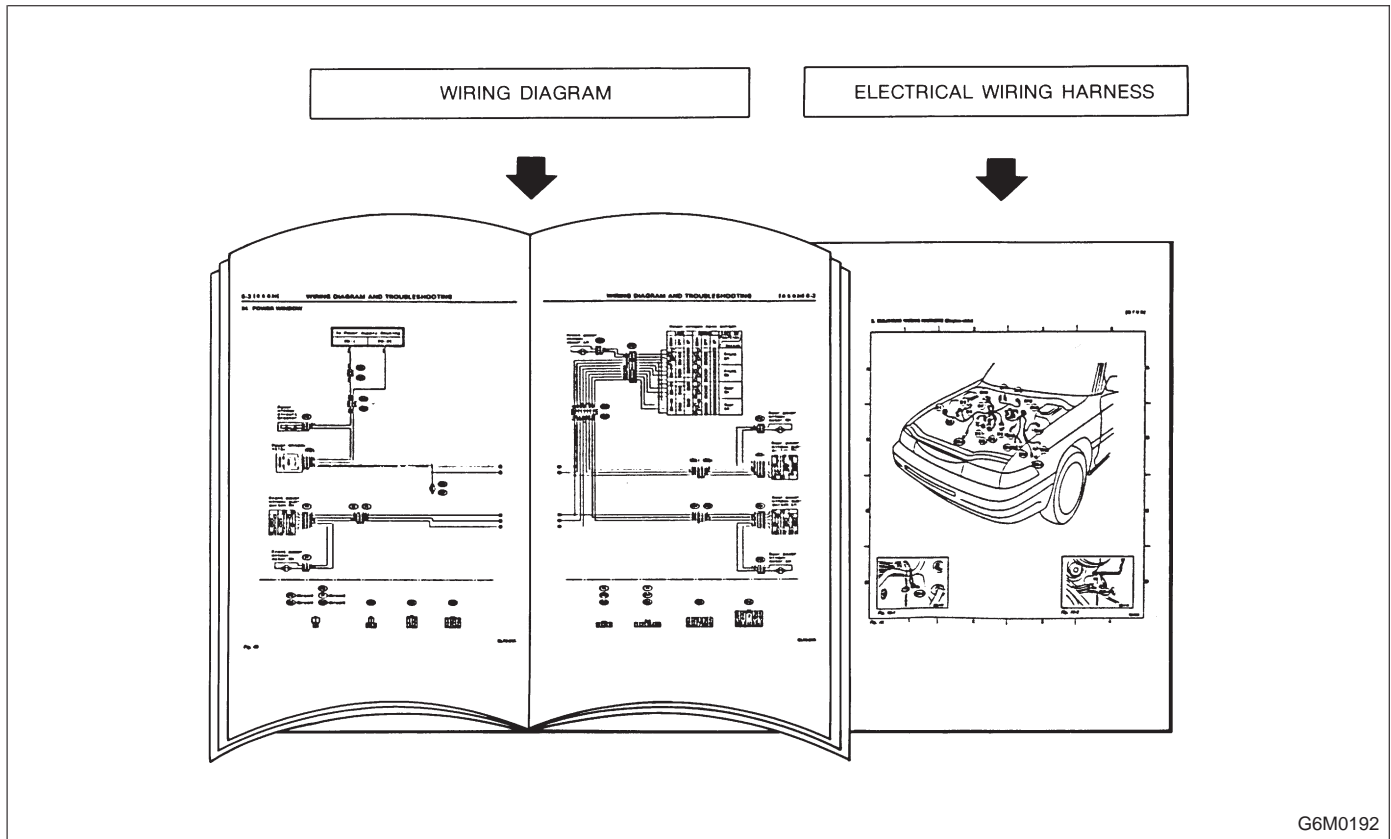

G6M0192

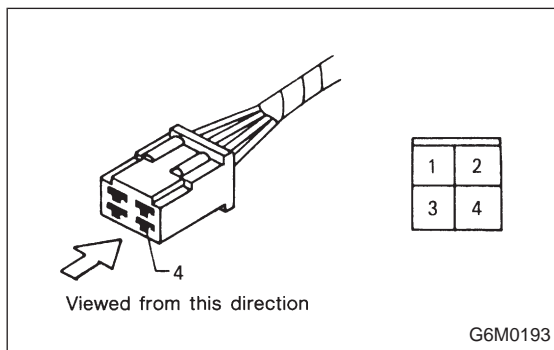

G6M0193

## 2. WIRING DIAGRAM

The wiring diagram of each system is illustrated so that you can understand the path through which the electric current flows from the battery.

Sketches and codes are used in the diagrams. They should read as follows:

- 1) Each connector and its terminal position are indicated by a sketch of the connector in a disconnected state which is viewed from the front, as shown in figure.

2) The number of poles or pins, presence of a lock, and pin number of each terminal are indicated in the sketch of each connector.

In the sketch, the highest pole number refers to the number of poles which the connector has. For example, the sketch of the connector shown in figure indicates the connector has 9 poles.

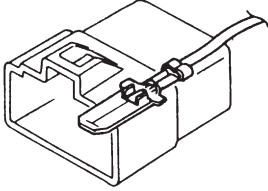
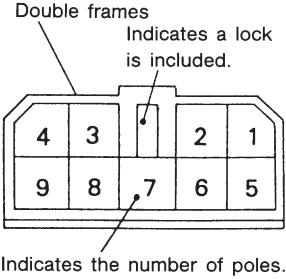
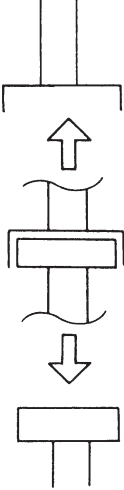
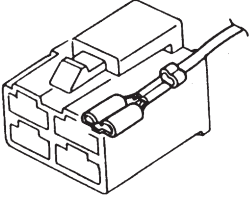
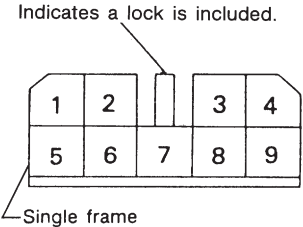
Connector used in vehicle	Connector shown in wiring diagram		
	Sketch	Symbol	Number of poles
 <p>G6M0194</p>	 <p>G6M0196</p>	 <p>G6M0198</p>	<p>Numbered in order from upper right to lower left.</p>
 <p>G6M0195</p>	 <p>G6M0197</p>		

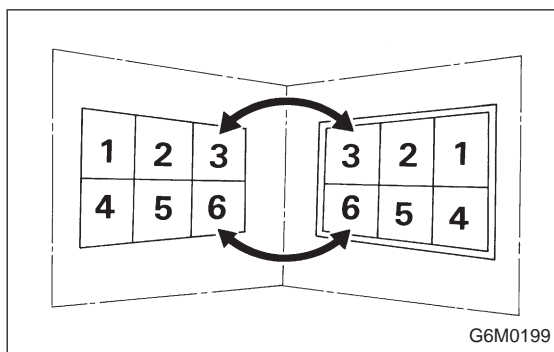

When one set of connectors is viewed from the front side, the pole numbers of one connector are symmetrical to those of the other. When these two connectors are connected as a unit, the poles which have the same number are joined.

3) Electrical wiring harness

The connectors are numbered along with the number of poles, external colors, and mating connections in the accompanying list.

1. General Description

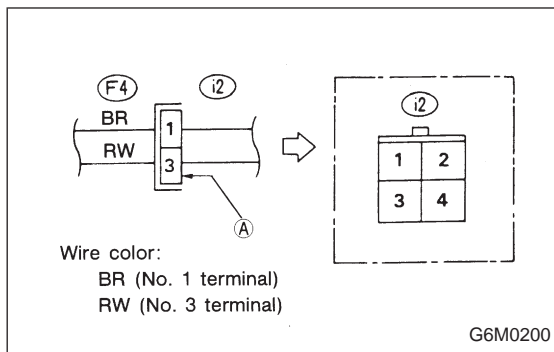

4) The sketch of each connector in the wiring diagram usually shows the “A” side of the connector. The relationship between the wire color, terminal number and connector is described in figure.

NOTE:

A wire which runs in one direction from a connector terminal sometimes may have a different color from that which runs in the other direction from that terminal.

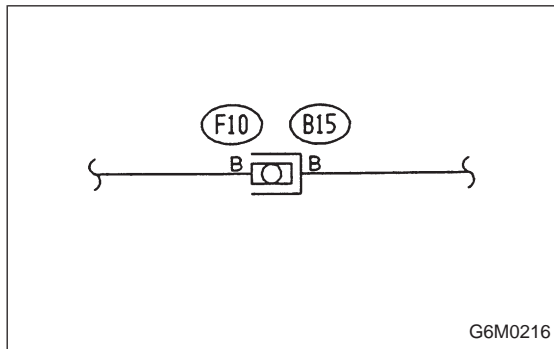

5) In wiring diagram, connectors which have no terminal number refer to one-pole types. Sketches of these connectors are omitted intentionally.

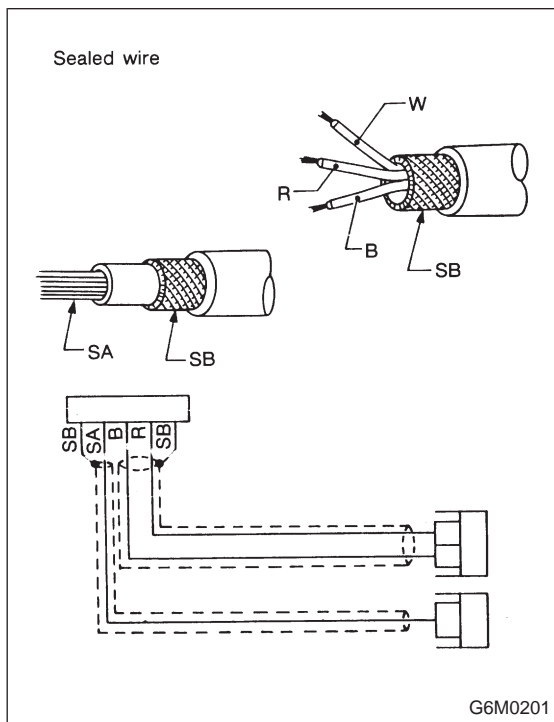

6) The following color codes are used to indicate the colors of the wires used.

Color code	Color
L	Blue
B	Black
Y	Yellow
G	Green
R	Red
W	White
Br	Brown
Lg	Light green
Gr	Gray
P	Pink
Or	Orange
Lb	Light Blue
V	Violet
SA	Sealed (Inner)
SB	Sealed (Outer)

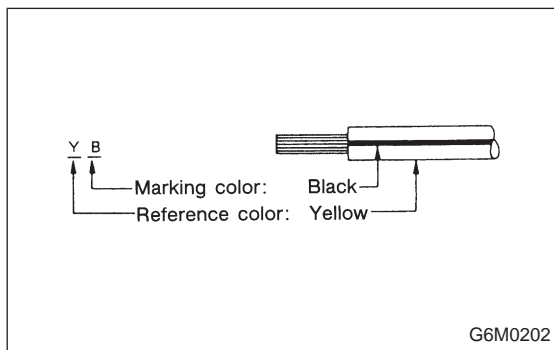

7) The wire color code, which consists of two letters (or three letters including Br or Lg), indicates the standard color (base color of the wire covering) by its first letter and the stripe marking by its second letter.

8) The table below lists the nominal sectional areas and allowable currents of the wires.

Nominal sectional area mm <sup>2</sup>	No. of strands/ strand diameter	Outside diameter of finished wiring mm	Allowable current Amps/40°C
0.3	7/0.26	1.8	7
0.5	7/0.32	2.2 (or 2.0)	12
0.75	30/0.18	2.6 (or 2.4)	16
0.85	11/0.32	2.4 (or 2.2)	16
1.25	16/0.32	2.7 (or 2.5)	21
2	26/0.32	3.1 (or 2.9)	28
3	41/0.32	3.8 (or 3.6)	38
5	65/0.32	4.6 (or 4.4)	51
8	50/0.45	5.5	67

**CAUTION:**

**When replacing or repairing a wire, be sure to use the same size and type of the wire which was originally used.**

**NOTE:**

- The allowable current in the above table indicates the tolerable amperage of each wire at an ambient temperature of 40°C (104°F).
- The allowable current changes with ambient temperature. Also, it changes if a bundle of more than two wires is used.

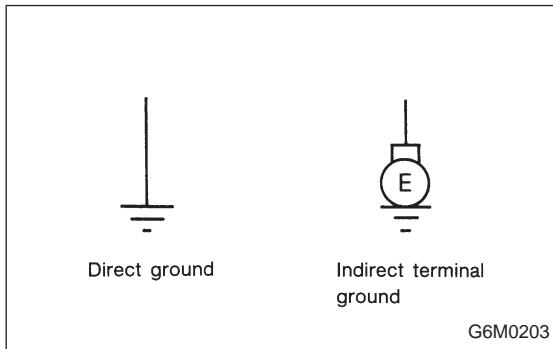

9) Each unit is directly grounded to the body or indirectly grounds through a harness ground terminal. Different symbols are used in the wiring diagram to identify the two grounding systems.

The ground points shown in the wiring diagram refer to the following:

- Ⓞ GB Body ground
- Ⓞ GE Engine ground
- Ⓞ GR Radio ground
- Ⓞ GD Rear defogger ground

All wiring harnesses are provided with a ground point which should be securely connected.

10) Relays are classified as normally-open or normally-closed.  
 The normally-closed relay has one or more contacts.  
 The wiring diagram shows the relay mode when the energizing circuit is OFF.

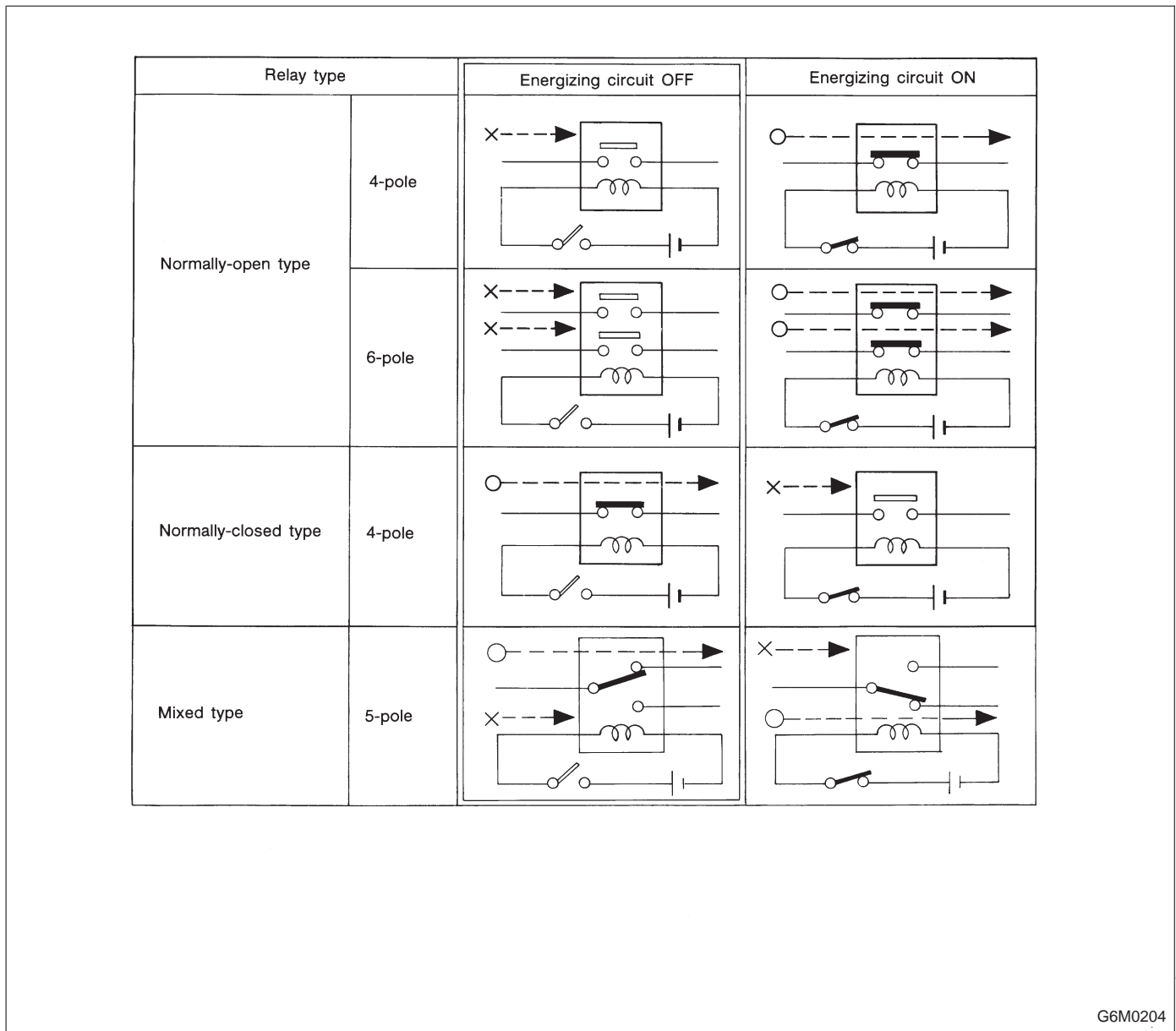

G6M0204

**Key to symbols:**

○ → : Current flows.

X → : Current does not flow.

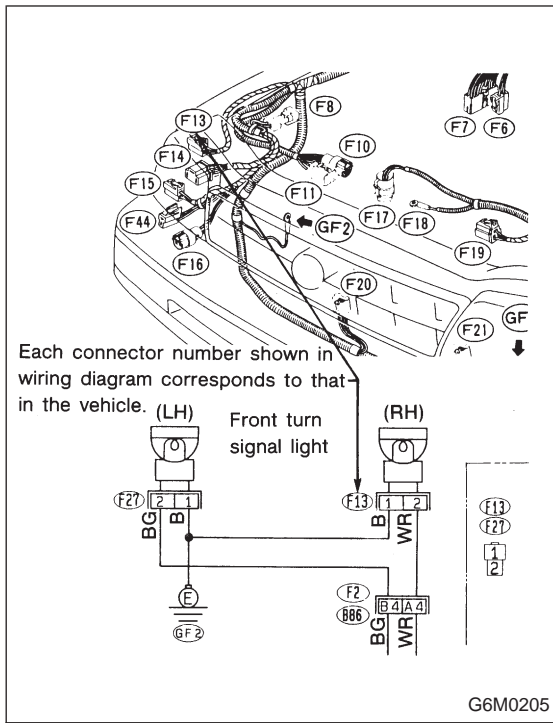

11) Each connector number shown in the wiring diagram corresponds to that in the wiring harness. The location of each connector in the actual vehicle is determined by reading the first character of the connector (for example, a "F" for F8, "i" for i16, etc.) and the type of wiring harness. The first character of each connector number refers to the area or system of the vehicle, as indicated in table below.

Symbol	Wiring harness and Cord
F	Front wiring harness
B	Bulkhead wiring harness
E	Engine wiring harness
T	Transmission cord
D	Door cord LH & RH, Rear gate cord
I	Instrument panel wiring harness
R	Rear wiring harness, Rear defogger cord Room light cord, Fuel tank cord, Sunroof cord, Trunk lid cord
P	Floor wiring harness

## 2. Basic Diagnostics Procedures

The most important purpose of diagnostics is to determine which part is malfunctioning quickly, to save time and labor.

### A: IDENTIFICATION OF TROUBLE SYMPTOM

Determine what the problem is based on the symptom.

### B: PROBABLE CAUSE OF TROUBLE

Look at the wiring diagram and check the system's circuit. Then check the switch, relay, fuse, ground, etc.

### C: LOCATION AND REPAIR OF TROUBLE

- 1) Using the diagnostics narrow down the causes.
- 2) If necessary, use a voltmeter, ohmmeter, etc.
- 3) Before replacing certain component parts (switch, relay, etc.), check the power supply, ground, for open wiring harness, poor connectors, etc. If no problems are encountered, check the component parts.

### D: CONFIRMATION OF SYSTEM OPERATION

After repairing, ensure that the system operates properly.

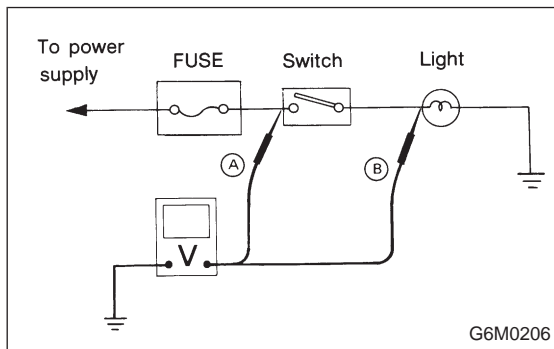

### E: INSPECTION

#### 1. VOLTAGE MEASUREMENT

- 1) Using a voltmeter, connect the negative lead to a good ground point or negative battery terminal and the positive lead to the connector or component terminal.
- 2) Contact the positive probe of the voltmeter on connector (A).

The voltmeter will indicate a voltage.

- 3) Shift the positive probe to connector (B). The voltmeter will indicate no voltage.

With test set-up held as it is, turn switch ON. The voltmeter will indicate a voltage and, at the same time, the light will come on.

- 4) The circuit is in good order. If a problem such as a lamp failing to light occurs, use the procedures outlined above to track down the malfunction.



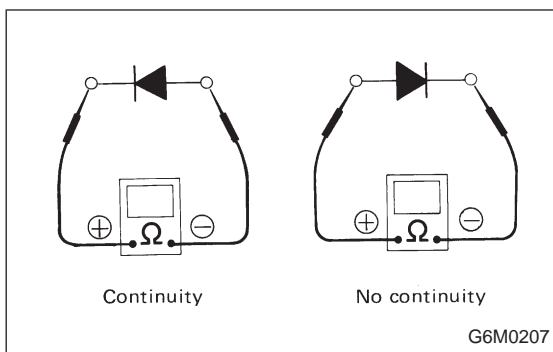

**2. CIRCUIT CONTINUITY CHECKS**

1) Disconnect the battery terminal or connector so there is no voltage between the check points. Contact the two leads of an ohmmeter to each of the check points.

If the circuit has diodes, reverse the two leads and check again.

2) Use an ohmmeter to check for diode continuity.

When contacting the negative lead to the diode positive side and the positive lead to the negative side, there should be continuity.

When contacting the two leads in reverse, there should be no continuity.

3) Symbol “o—o” indicates that continuity exists between two points or terminals. For example, when a switch position is “3”, continuity exists among terminals 1, 3 and 6, as shown in table below.

Terminal	1	2	3	4	5	6
Switch Position						
OFF						
1	○				○	○
2	○			○		○
3	○		○			○
4	○	○				○

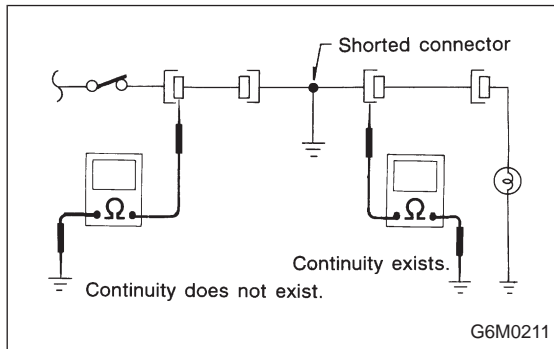
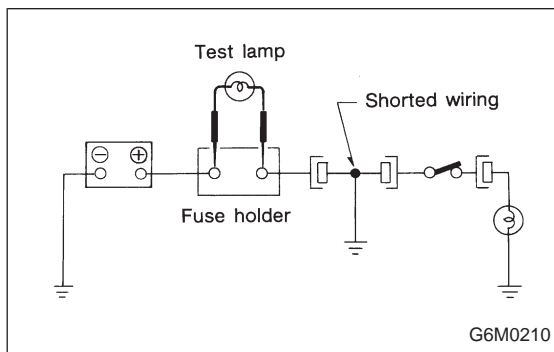
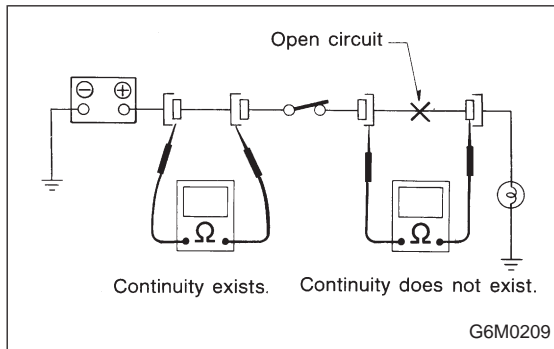
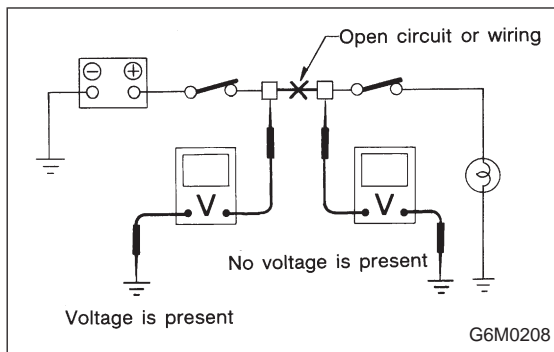

### 3. HOW TO DETERMINE AN OPEN CIRCUIT

#### 1) Voltmeter method

An open circuit is determined by measuring the voltage between respective connectors and ground using a voltmeter, starting with the connector closest to the power supply. The power supply must be turned ON so that current flows in the circuit. If voltage is not present between a particular connector and ground, the circuit between that connector and the previous connector is open.

#### 2) Ohmmeter method

Disconnect all connectors affected, and check continuity in the wiring between adjacent connectors. When the ohmmeter indicates "infinite", the wiring is open.

### 4. HOW TO DETERMINE A SHORT-CIRCUIT

#### 1) Test lamp method

Connect a test lamp (rated at approximately 3 watts) in place of the blown fuse and allow current to flow through the circuit. Disconnect one connector at a time from the circuit, starting with the one located farthest from the power supply. If the test lamp goes out when a connector is disconnected, the wiring between that connection and the next connector (farther from the power supply) is shorted.

#### 2) Ohmmeter method

Disconnect all affected connectors, and check continuity between each connector and ground. When ohmmeter indicates continuity between a particular connector and ground, that connector is shorted.

### 3. Working Precautions

#### 1. PRECAUTIONS WHEN WORKING WITH THE PARTS MOUNTED ON THE VEHICLE

- 1) When working under a vehicle which is jacked-up, always be sure to use safety stands.
- 2) The parking brake must always be applied during working. Also, in automatic transmission vehicles, keep the select lever set to the P (Parking) range.
- 3) Be sure the workshop is properly ventilated when running the engine. Further, be careful not to touch the belt or fan while the engine is operating.
- 4) Be careful not to touch hot metal parts, especially the radiator and exhaust system immediately after the engine has been shut off.

#### 2. PRECAUTIONS IN TROUBLE DIAGNOSIS AND REPAIR OF ELECTRIC PARTS

- 1) The battery cable must be disconnected from the battery's (-) terminal, and the ignition switch must be set to the OFF position, unless otherwise required by the diagnostics.
- 2) Securely fasten the wiring harness with clamps and slips so that the harness does not interfere with the body end parts or edges and bolts or screws.
- 3) When installing parts, be careful not to catch them on the wiring harness.

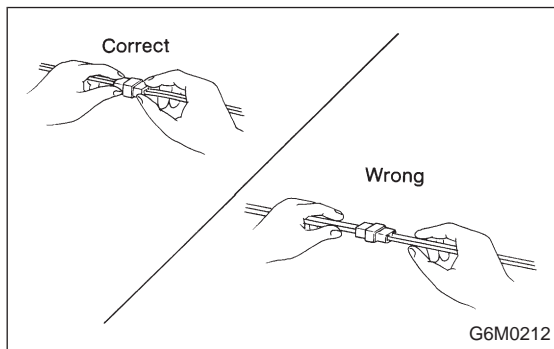

- 4) When disconnecting a connector, do not pull the wires, but pull while holding the connector body.

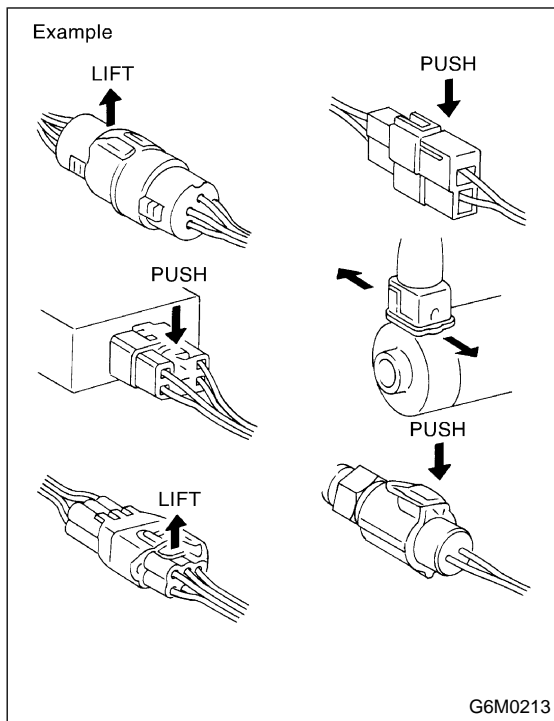

5) Some connectors are provided with a lock. One type of such a connector is disconnected by pushing the lock, and the other, by moving the lock up. In either type the lock shape must be identified before attempting to disconnect the connector.

To connect, insert the connector until it snaps and confirm that it is tightly connected.

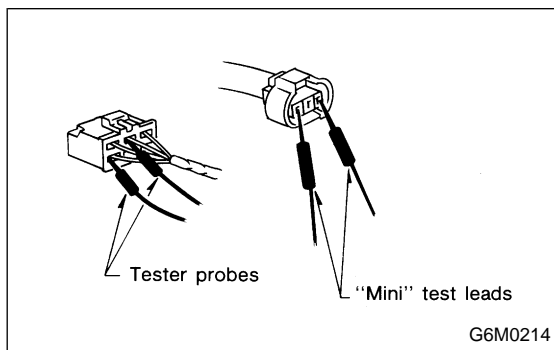

6) When checking continuity between connector terminals, or measuring voltage across the terminal and ground, always contact tester probe(s) on terminals from the wiring connection side. If the probe is too thick to gain access to the terminal, use "mini" test leads.

To check water-proof connectors (which are not accessible from the wiring side), contact test probes on the terminal side being careful not to bend or damage the terminals.

7) Sensors, relays, electrical unit, etc., are sensitive to strong impacts.

Handle them with care so that they are not dropped or mishandled.

### 4. How to Use Wiring Diagram

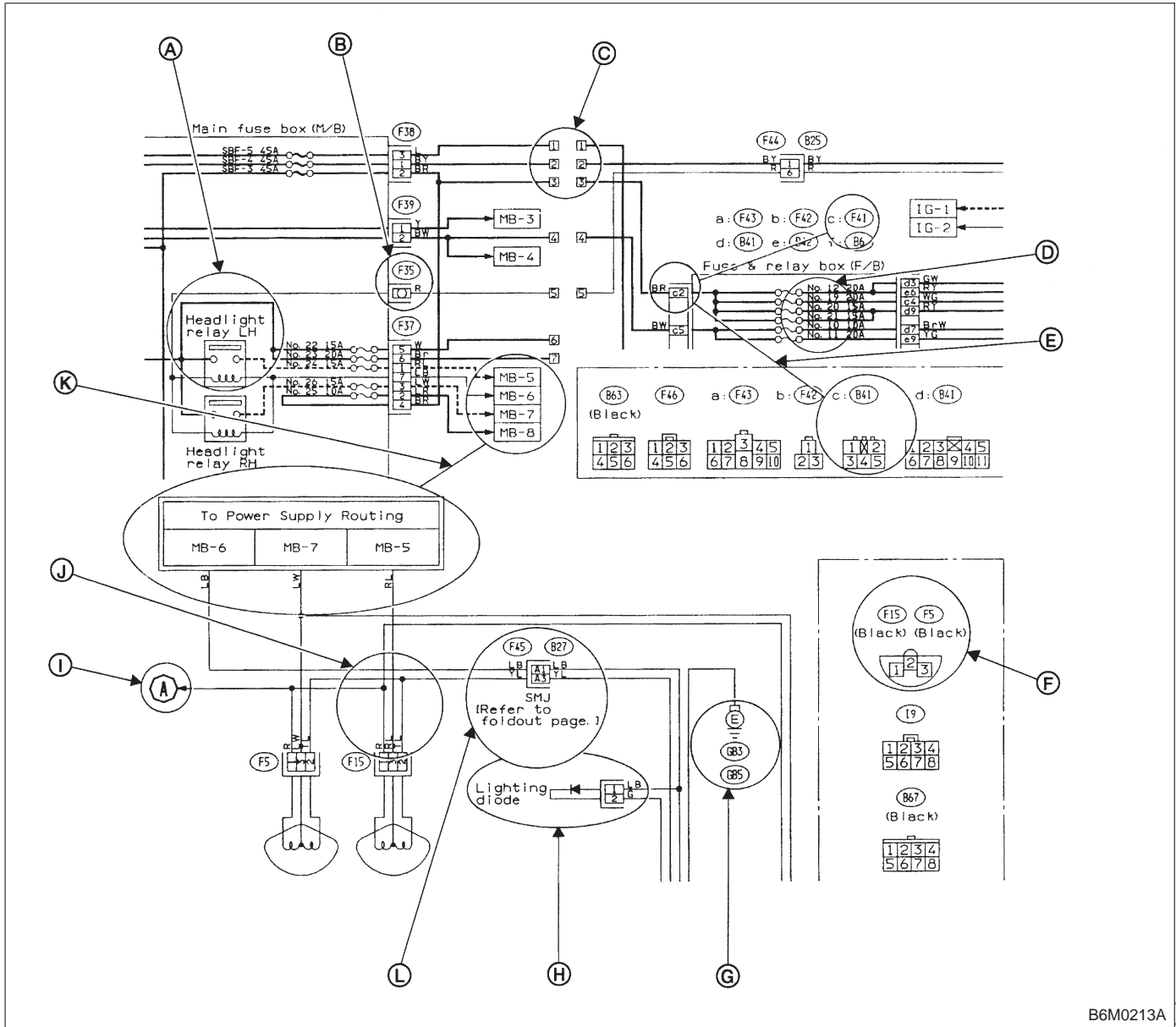

B6M0213A

**A: RELAY**

A symbol used to indicate a relay.

**B: CONNECTOR-1**

The sketch of the connector indicates the one-pole types.

**C: WIRING CONNECTION**

Some wiring diagrams are indicated in foldouts for convenience. Wiring destinations are indicated where necessary by corresponding symbols (as when two pages are needed for clear indication).

**D: FUSE No. & RATING**

The "FUSE No. & RATING" corresponds that used in the fuse box (main fuse box, and joint box).

**E: CONNECTOR-2**

1. Each connector is indicated by a symbol.
2. Each terminal number is indicated in the corresponding wiring diagram in an abbreviated form.
3. For example, terminal number "C2" refers to No. 2 terminal of connector (C:F41) shown in the connector sketch.

**F: CONNECTOR SKETCH**

1. Each connector sketch clearly identifies the shape and color of a connector as well as terminal locations. Non-colored connectors are indicated in natural color.
2. When more than two types of connector number are indicated in a connector sketch, it means that the same type connectors are used.

**G: GROUND**

Each grounding point can be located easily by referring to the corresponding wiring harness.

**H: DIODE**

A symbol is used to indicate a diode.

**I: WIRE TRACING ON EXTENDED WIRING DIAGRAMS**

For a wiring diagram extending over at least two pages, a symbol (consisting of the same characters with arrows), as shown below, facilitates wire tracing from one page to the next.

A ↔ A, B ↔ B

**J: SYMBOLS OF WIRE CONNECTION AND CROSSING**

 Symbol

Refers to wires which are connected and branched at the “dot” point.

 Symbol

Refers to wires which are crossed but not connected.

**K: POWER SUPPLY ROUTING**

A symbol is used to indicate the power supply in each wiring diagram.

“MB-5”, “MB-6”, etc., which are used as power supply symbols throughout the text, correspond with those shown in the POWER SUPPLY ROUTING in the wiring diagram.

Accordingly, using the POWER SUPPLY ROUTING and wiring diagrams permits service personnel to understand the entire electrical arrangement of a system.

**L: S.M.J.**

A symbol is used to indicate the terminal arrangement of the super multiple junction. The S.M.J. is not shown in respective wiring diagrams but is indicated on the next page.

**SYMBOLS AND ABBREVIATIONS**

A number of symbols and abbreviations are used in each wiring diagram to easily identify parts or circuits.

### 5. How to Use Super Multiple Junction (S.M.J.)

The "S.M.J." indicated in wiring diagrams is shown in a simplified form.

#### TERMINAL ARRANGEMENT

- LHD model

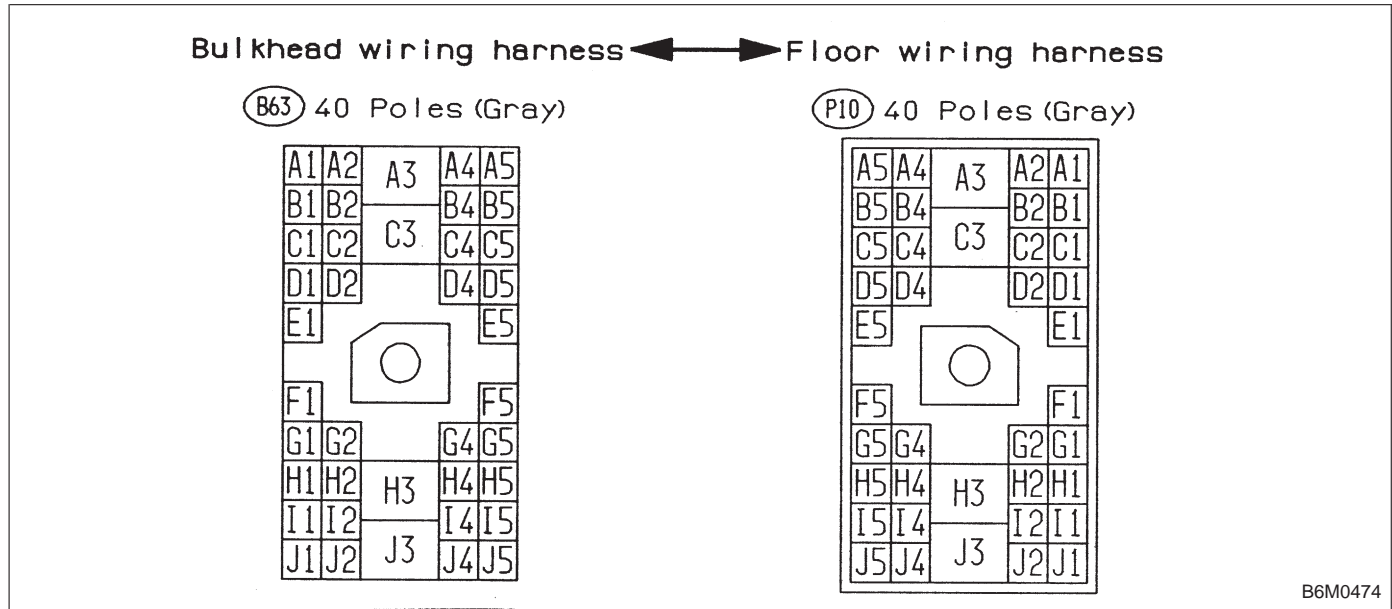

- RHD model

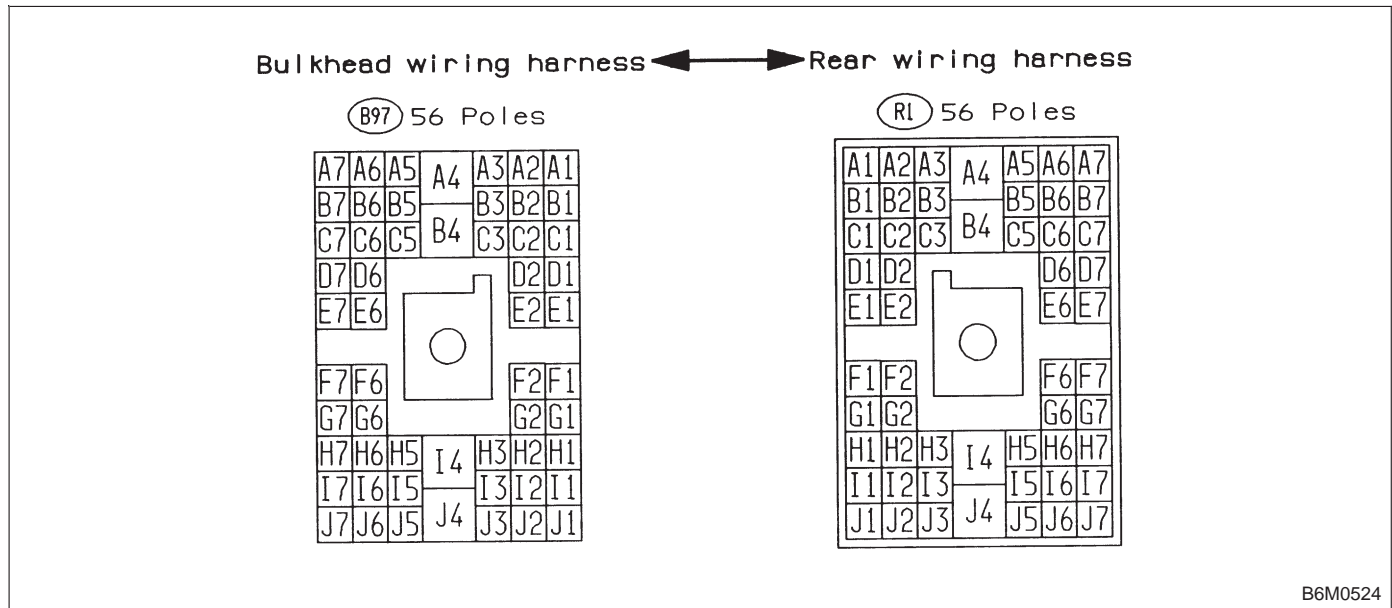

INSTALLATION

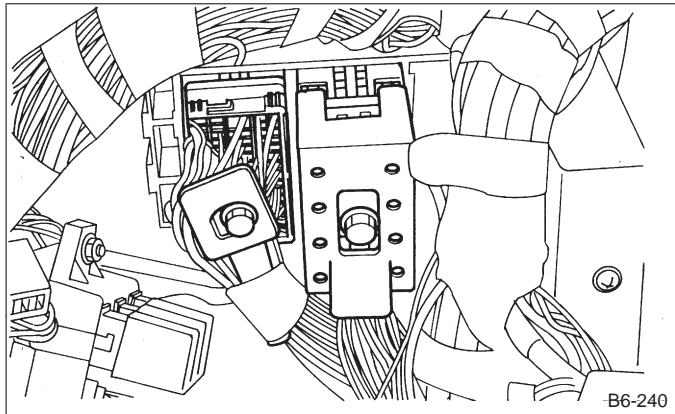

Tightening torque:

4.4 — 7.4 N·m (45 — 75 kg-cm, 39 — 65 in-lb)

NOTE:

- Align the cutout portion of one connector with that of other before tightening the connecting bolt.
- Do not tighten the bolt excessively since this may deform the connectors.

EXPLANATION OF S.M.J. SHOWN IN THE WIRING DIAGRAM

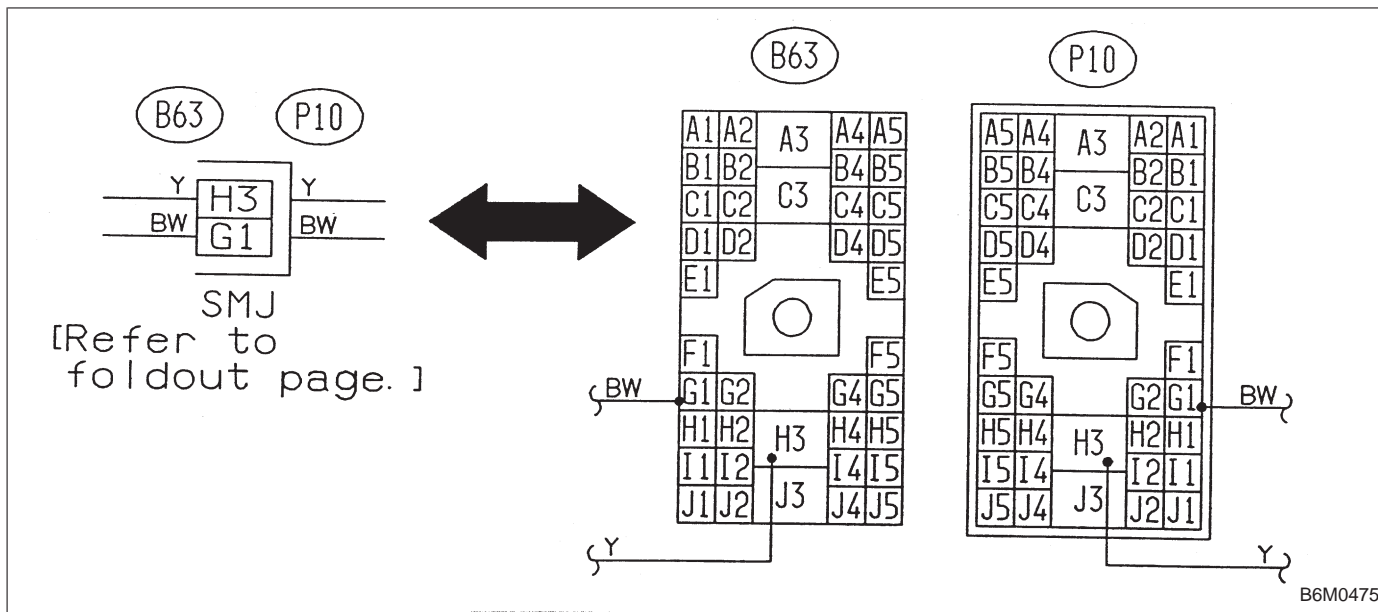



**ABBREVIATION LIST**

Abbr.	Full name
A.B.S.	Antilock Brake System
ACC	Accessory
A/C	Air Conditioning
AD	Auto Down
AT	Automatic Transmission
AU	Auto Up
+B	Battery
DN	Down
DRL	Daytime Running Light
E	Ground
F/B	Fuse & Joint Box
FL1.5	Fusible link 1.5 mm <sup>2</sup>
IG	Ignition
Illumi.	Illumination

Abbr.	Full name
LH	Left Hand
Lo	Low
M	Motor
M/B	Main Fuse Box
MG	Magnet
Mi	Middle
OP	Optional Parts
PASS	Passing
RH	Right Hand
SBF	Slow Blow Fuse
S.M.J.	Super Multiple Junction
ST	Starter
SW	Switch
T.C.S.	Traction Control System
UP	Up
WASH	Washer

# 6. Wiring Diagram

## 1. POWER SUPPLY ROUTING

### ● LHD model

- Battery current
- Current from ignition switch IG terminal
- - - Current from ignition switch ACC terminal
- Other currents

\*RB : With security system  
R : Without security system

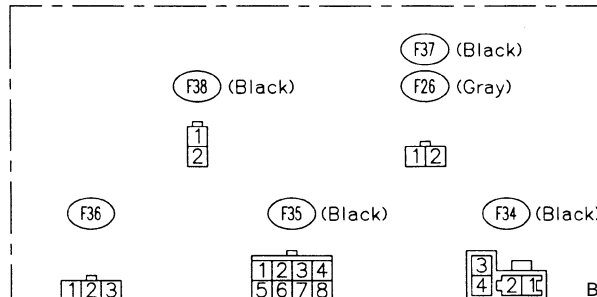
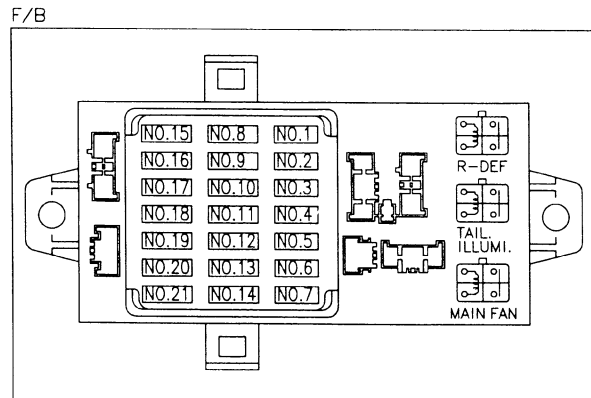
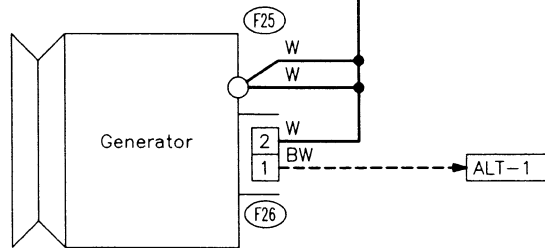
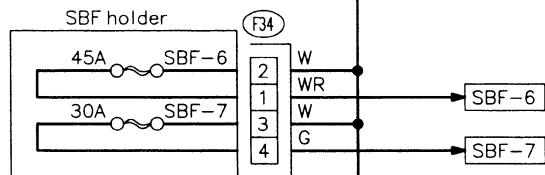
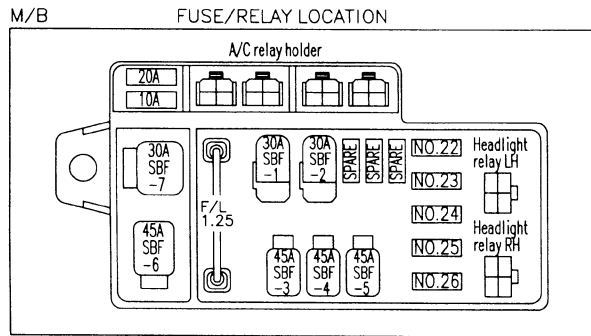
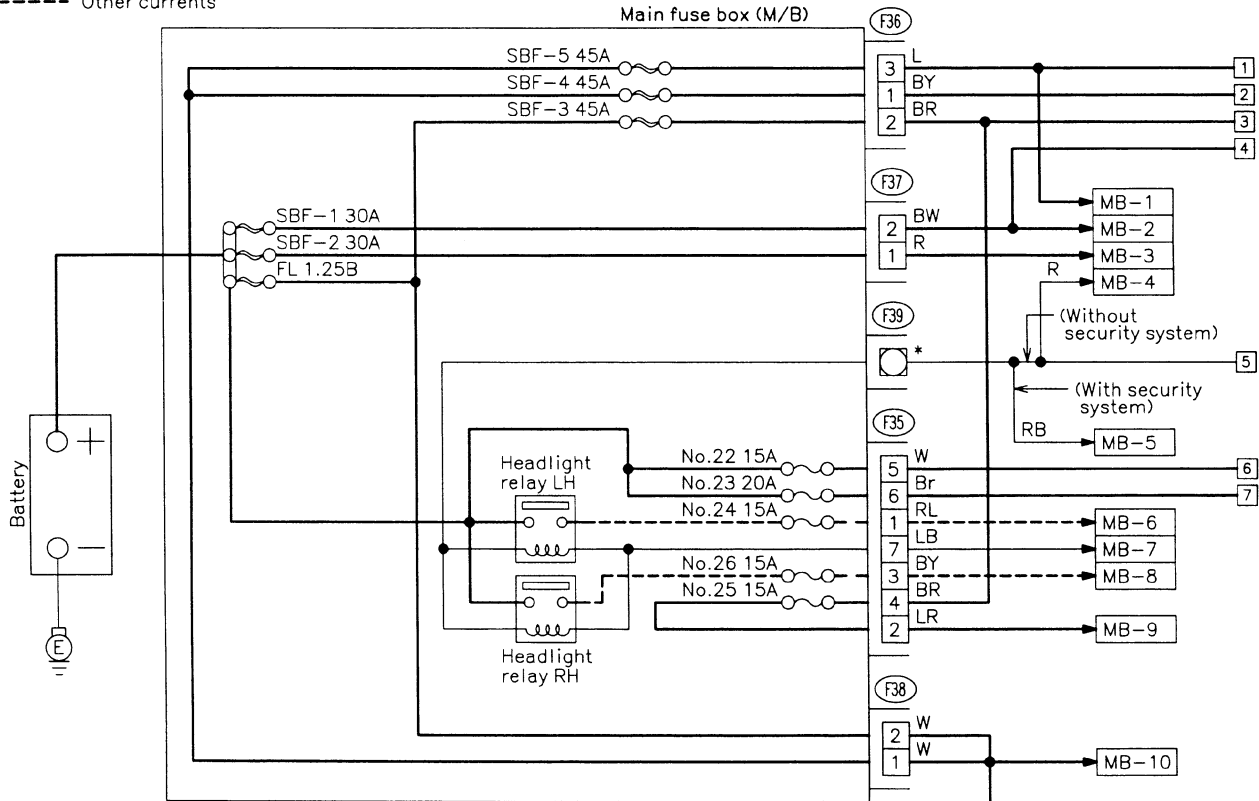

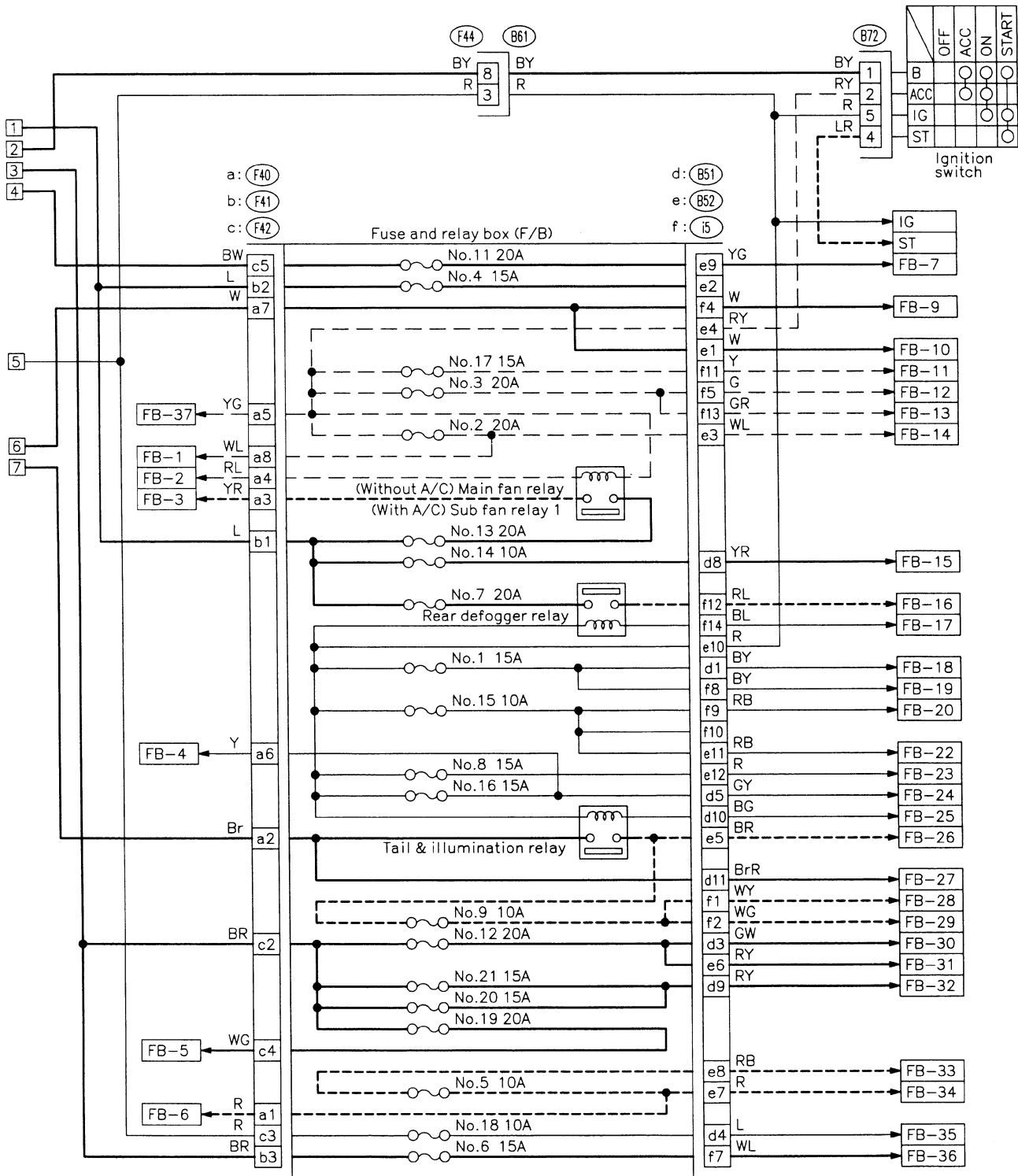

(F44)

(B72)  
(Black)

(F40)  
(Gray)

(F41)  
(Gray)

(F42)  
(Gray)

(B51)  
(Gray)

(B52)  
(Gray)

(i5)  
(Gray)

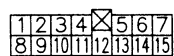
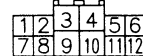
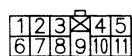
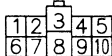

## 6. Wiring Diagram

No.	Load
MB-1	Fuse holder (Rear power supply & seat heater)
MB-2	Power window circuit breaker
MB-3	Engine control module Fuel pump relay Main relay OBD-II service connector
MB-4	A/C relay holder
MB-5	Headlight alarm relay (with security)
MB-6	Headlight LH
MB-7	Daytime running light control module Diode (Lighting) Diode (Security) Lighting switch
MB-8	Combination meter Front fog light switch Headlight RH Front fog light relay
MB-9	Door lock timer Headlight alarm relay Interrupt relay Radio Security control module Security indicator light Spot light Room light Step light Combination meter Luggage room light Trailer connector Trunk room light
MB-10	A/C relay holder
SBF-6	ABS relay box TCS motor relay
SBF-7	TCS valve relay
ALT-1	Combination meter Daytime running light control module Diode (TCS)
IG	Headlight alarm relay
ST	Cruise control module Engine control module Inhibitor switch (AT) Interrupt relay Starter interlock relay (MT)
FB-1	Front washer motor Rear washer motor
FB-2	Engine control module Main fan relay 1
FB-3	Sub fan relay 2 Sub fan motor
FB-4	Engine control module Fuel pump relay Ignition coil Transmission control module

No.	Load
FB-5	ABS relay box
FB-6	Side marker light LH Side marker light RH
FB-7	Door lock timer
FB-9	Hazard switch
FB-10	AT shift lock control module Key warning switch Power antenna
FB-11	Radio
FB-12	Front accessory power supply
FB-13	Mirror heater Rear power supply relay Remote control rearview mirror switch Security control module Vanity mirror illumination light
FB-14	AT shift lock control module Combination switch Front wiper motor Rear wiper motor Rear wiper relay
FB-15	ABS/TCS control module Transmission control module
FB-16	Rear defogger Rear defogger condenser Rear defogger switch
FB-17	Rear defogger switch
FB-18	AT shift lock control module Back-up light switch (MT) Inhibitor switch (AT)
FB-19	Hazard switch
FB-20	A/C switch Combination meter Mode control panel TCS off switch
FB-22	Blower motor relay Check connector Daytime running light control module Daytime running light relay FRESH/RECIRC actuator Hi-beam relay Power window and sunroof relay Seat belt timer
FB-23	Airbag control module
FB-24	Airbag control module
FB-25	Lighting switch

No.	Load
FB-26	Parking switch
FB-27	Parking switch
FB-28	Illumination light
FB-29	Illumination light
FB-30	Pedal stroke switch Stop light switch Stop & brake switch
FB-31	Horn relay
FB-32	Blower motor relay
FB-33	Parking switch
FB-34	License plate light Rear combination light LH Rear combination light RH Rear finisher light LH Rear finisher light RH
FB-35	ABS control module ABS/TCS control module TCS valve relay Cruise control main switch Cruise control module
FB-36	Front fog light relay
FB-37	Main fan relay 1

# WIRING DIAGRAM

## 1. POWER SUPPLY ROUTING

### ● RHD model

- Battery current
- Current from ignition switch IG terminal
- - - Current from ignition switch ACC terminal
- Other currents

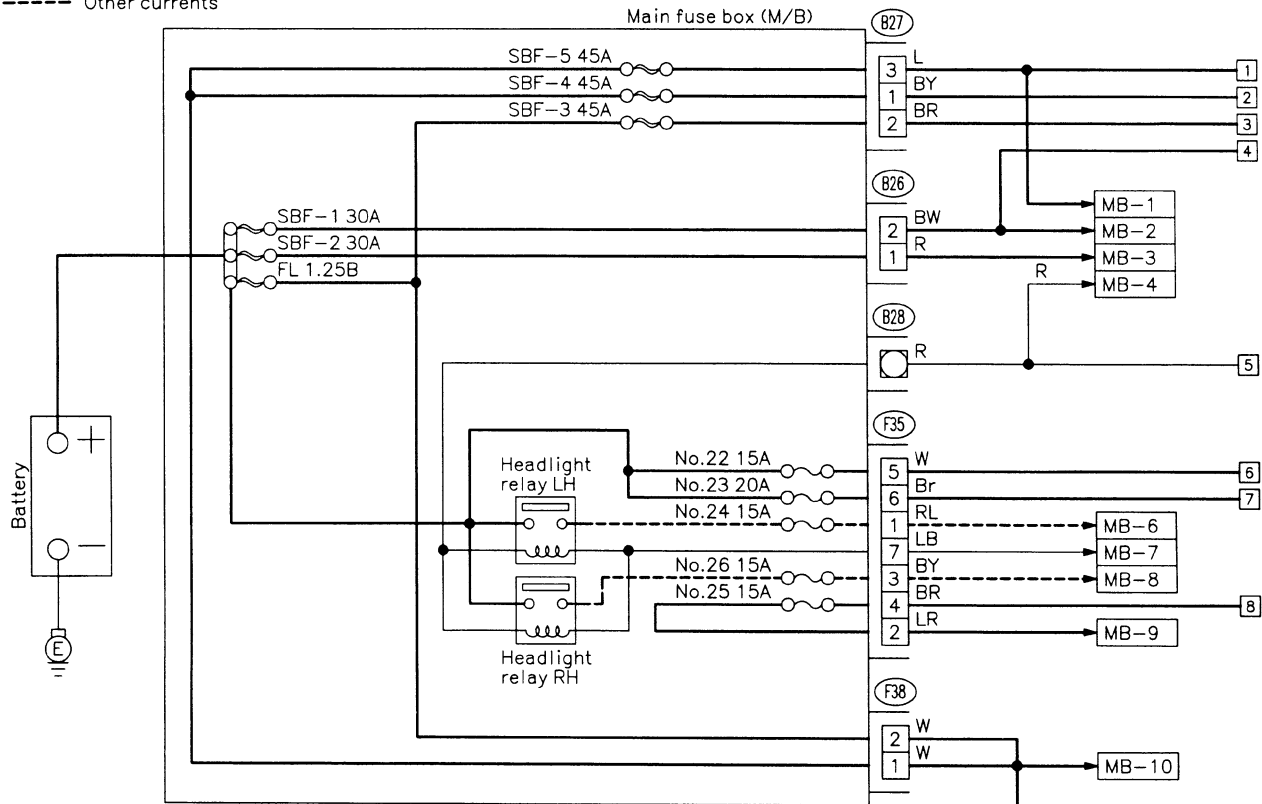

M/B FUSE/RELAY LOCATION

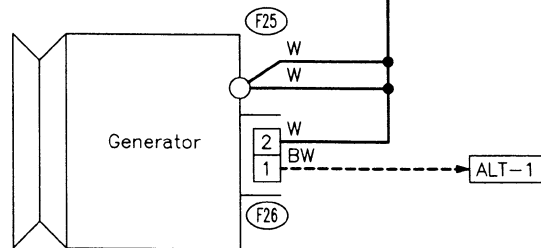
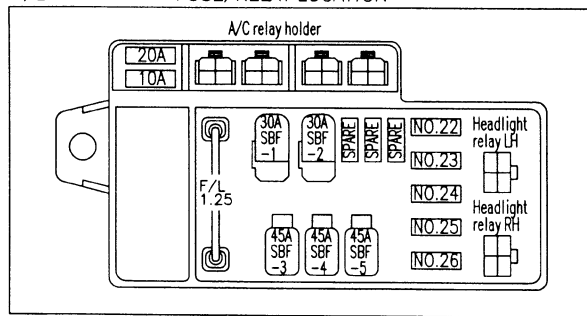

F/B

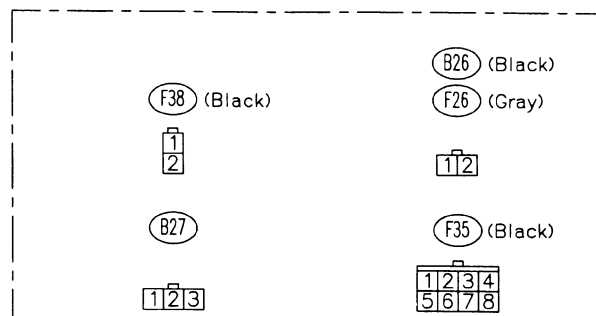
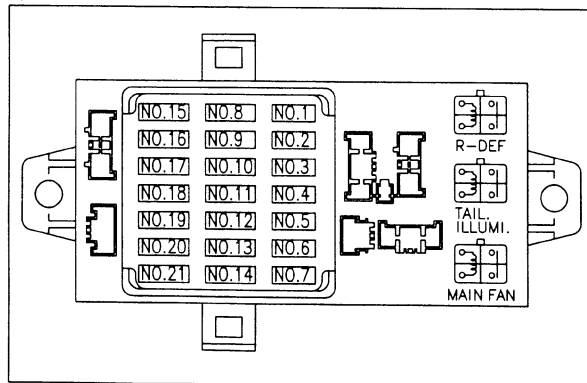

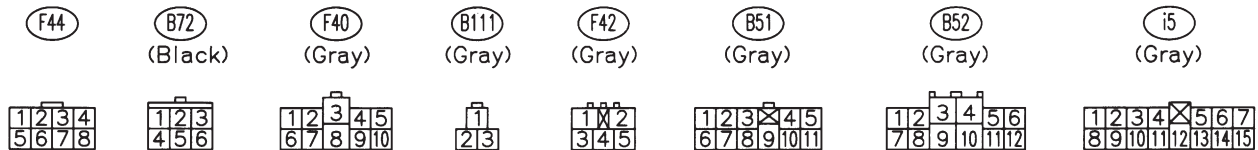
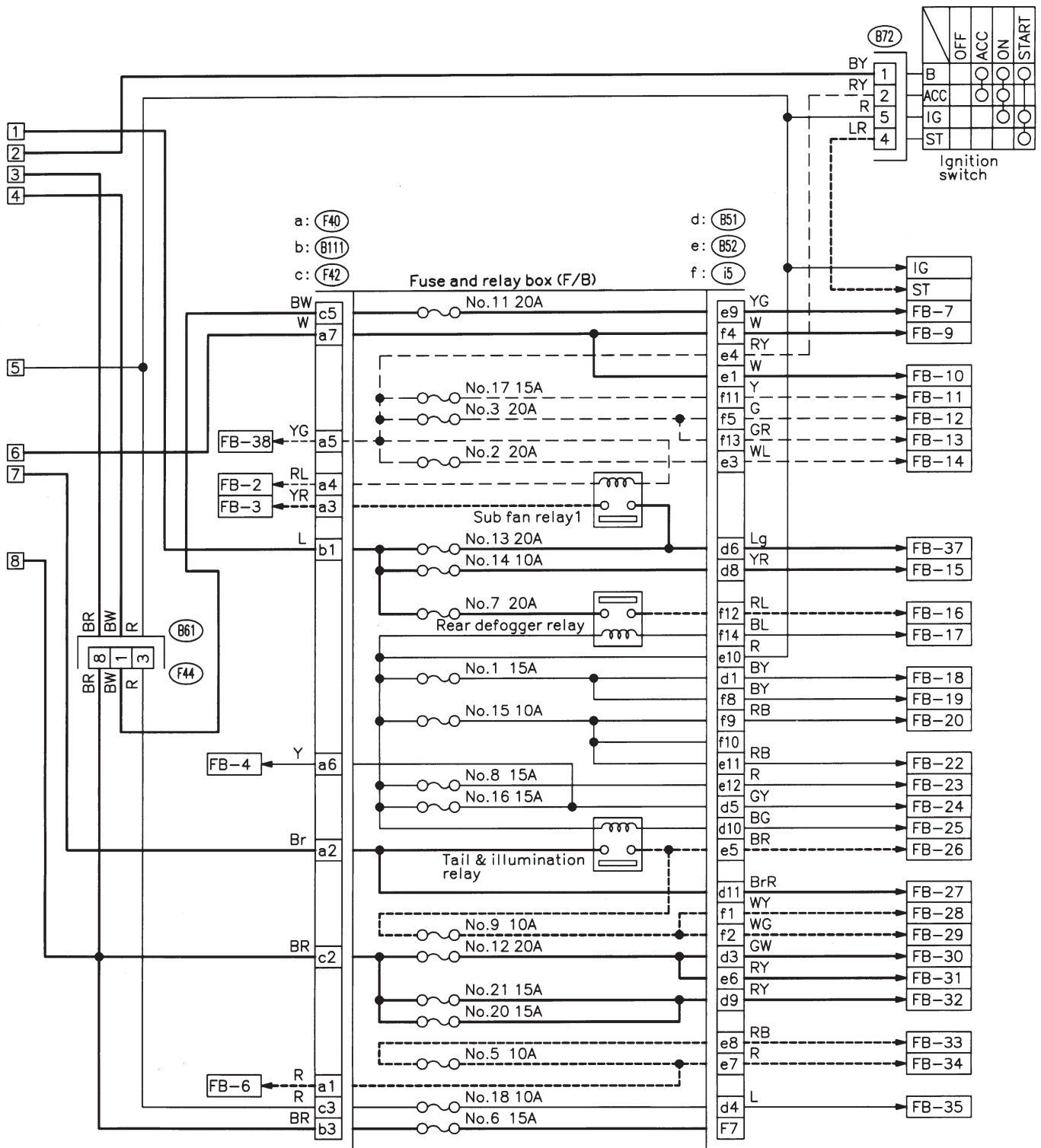

## 6. Wiring Diagram

No.	Load
MB-2	Power window circuit breaker
MB-3	Engine control module Fuel pump relay Main relay OBD-II service connector
MB-4	A/C relay holder
MB-6	Headlight LH
MB-7	Diode (Lighting) Lighting switch
MB-8	Combination meter Headlight RH
MB-9	Combination meter Door lock timer Luggage room light Radio Room light
MB-10	A/C relay holder
ALT-1	Combination meter
IG	A/C relay holder
ST	Cruise control module Engine control module Inhibitor switch
FB-2	Engine control module Main fan relay 1
FB-3	Sub fan motor Sub fan relay-2
FB-4	Engine control module Fuel pump relay Ignition coil Transmission control module
FB-6	Side marker light LH Side marker light RH
FB-7	Door lock timer
FB-9	Hazard switch
FB-10	AT shift lock control module Key warning switch Power antenna
FB-11	Radio
FB-12	Cigarette lighter
FB-13	Remote control rearview mirror switch
FB-14	AT shift lock control module Combination switch Front washer motor Front wiper motor Rear washer motor Rear wiper motor Rear wiper relay

No.	Load
FB-15	Transmission control module
FB-16	Rear defogger Rear defogger condenser Rear defogger switch
FB-17	Rear defogger switch
FB-18	AT shift lock control module Inhibitor switch
FB-19	Hazard switch
FB-20	Combination meter Mode control panel
FB-22	Blower motor relay Check connector FRESH/RECIRC actuator Mode actuator Power window relay Seat belt timer
FB-23	Airbag control module
FB-24	Airbag control module
FB-25	Lighting switch
FB-26	Parking switch
FB-27	Parking switch
FB-28	Illumination light
FB-29	Illumination light
FB-30	Stop light switch Stop & brake switch
FB-31	Horn relay
FB-32	Blower motor relay
FB-33	Parking switch
FB-34	License plate light LH License plate light RH Rear combination light LH Rear combination light RH Rear finisher light LH Rear finisher light RH
FB-35	Cruise control main switch Cruise control module
FB-38	Main fan relay 1



2. GROUND DISTRIBUTION

● LHD model

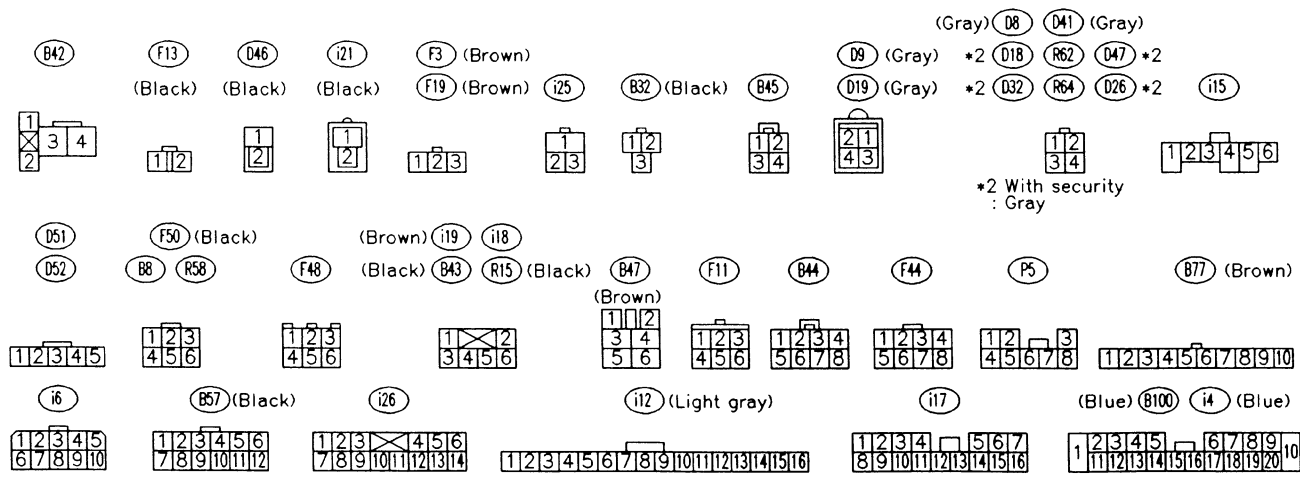
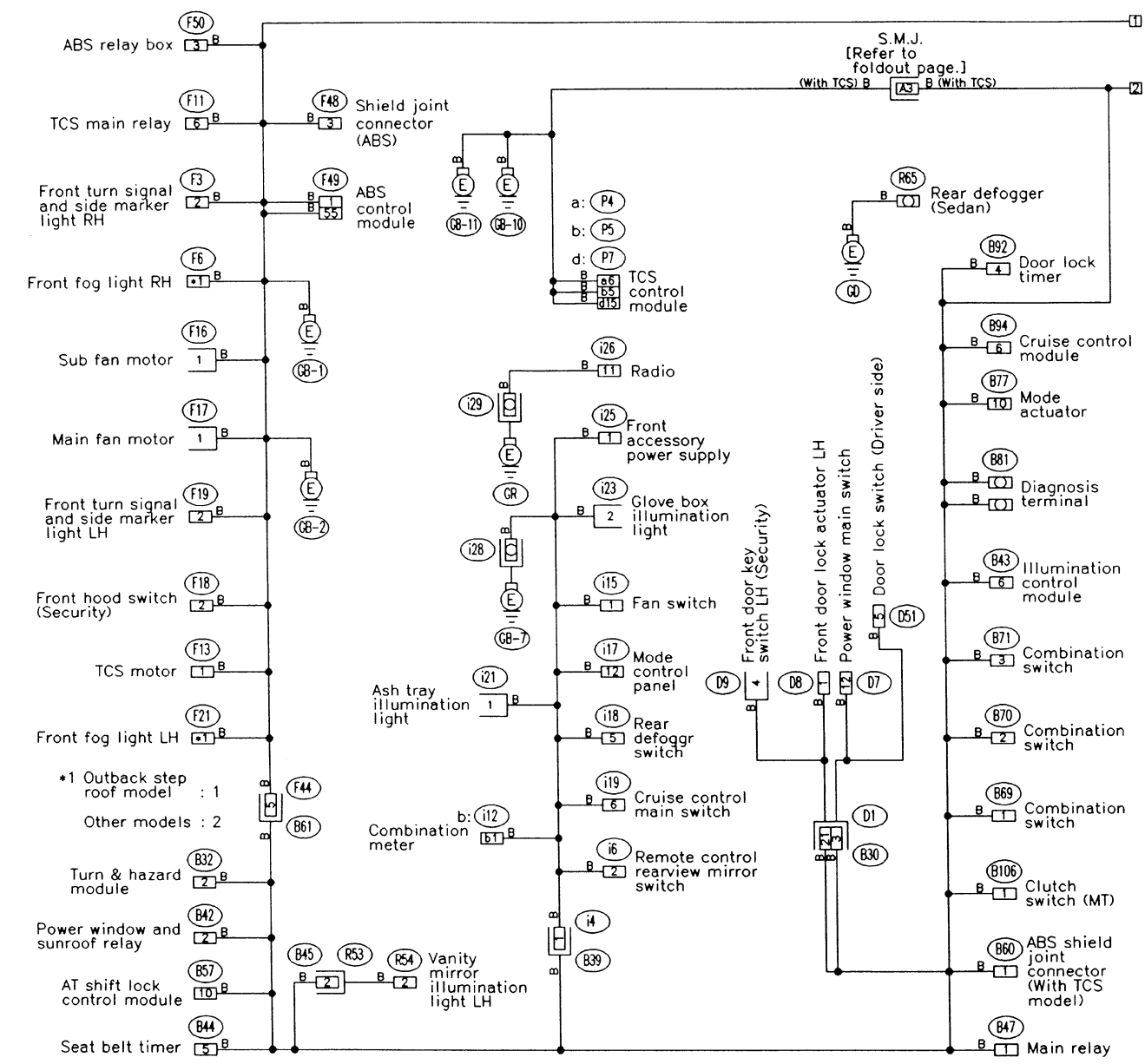

6. Wiring Diagram

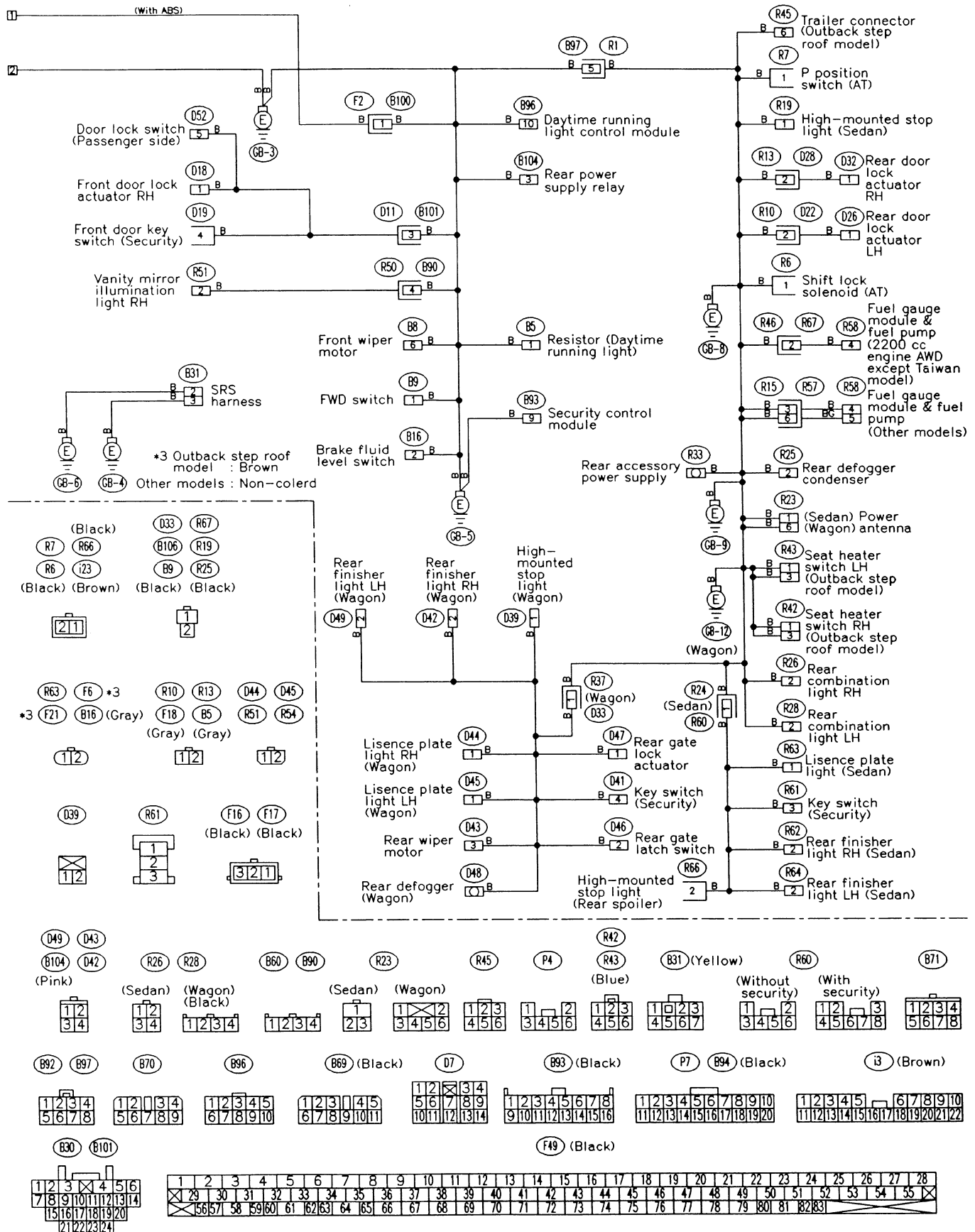

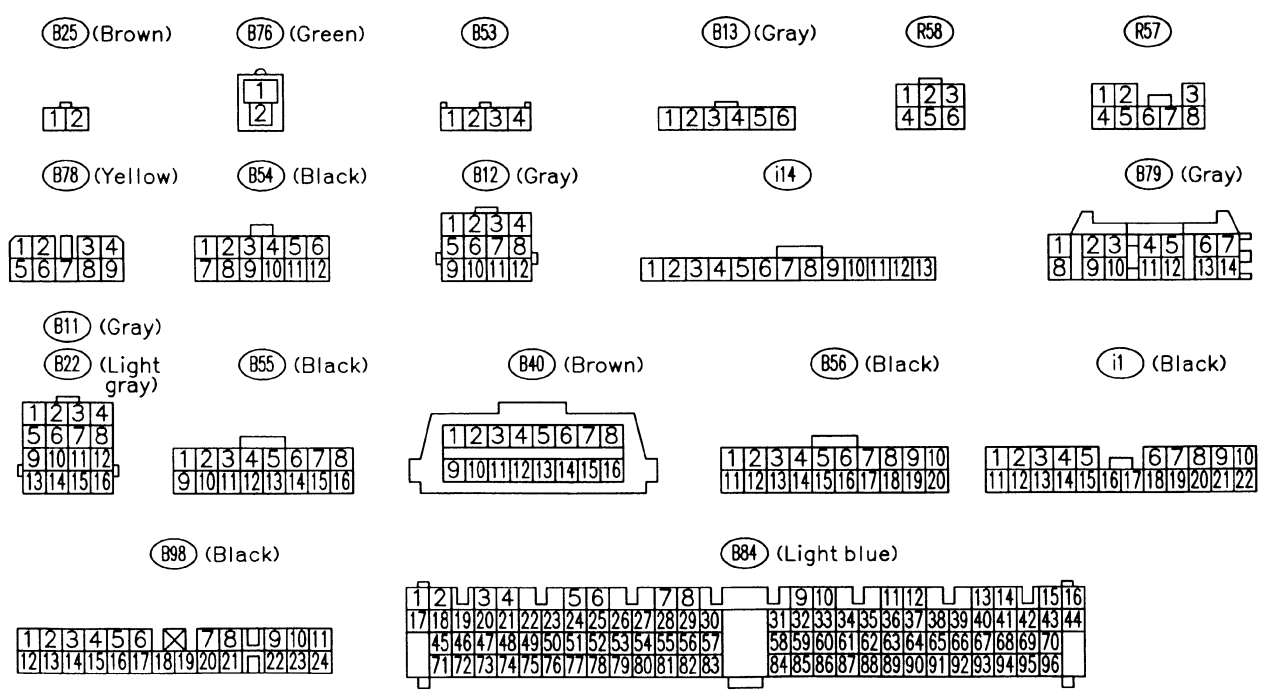
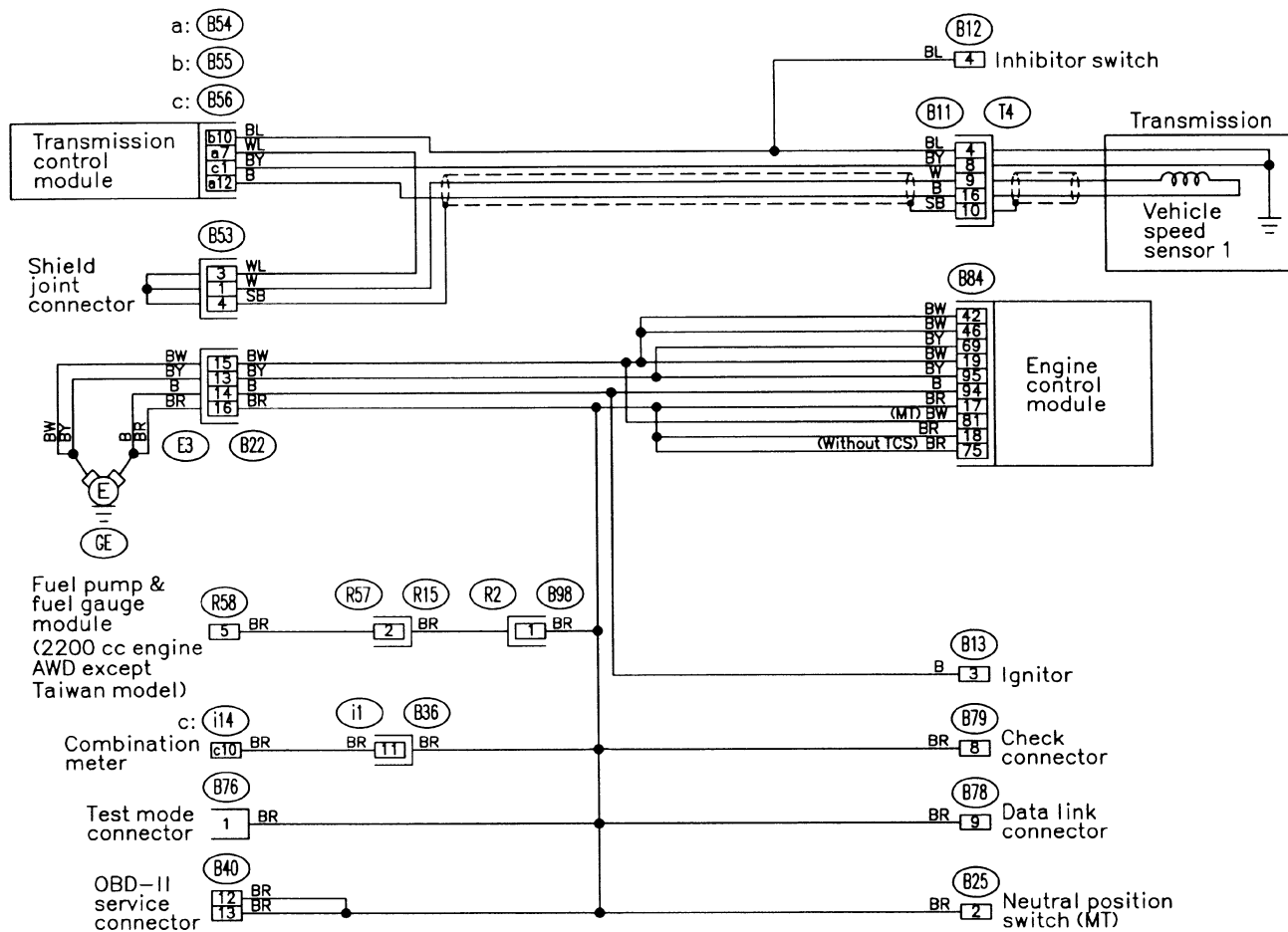

2. GROUND DISTRIBUTION

● RHD model

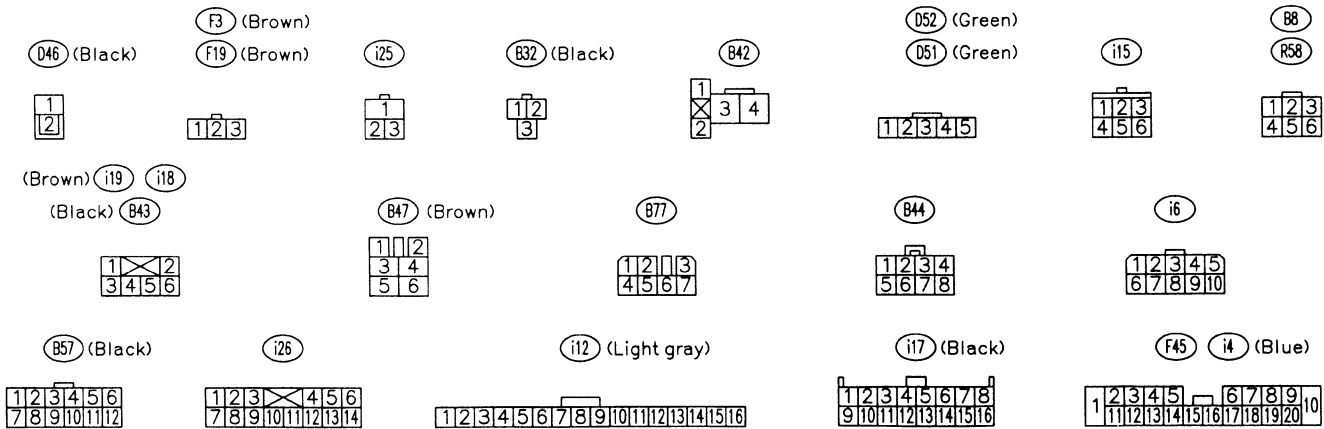
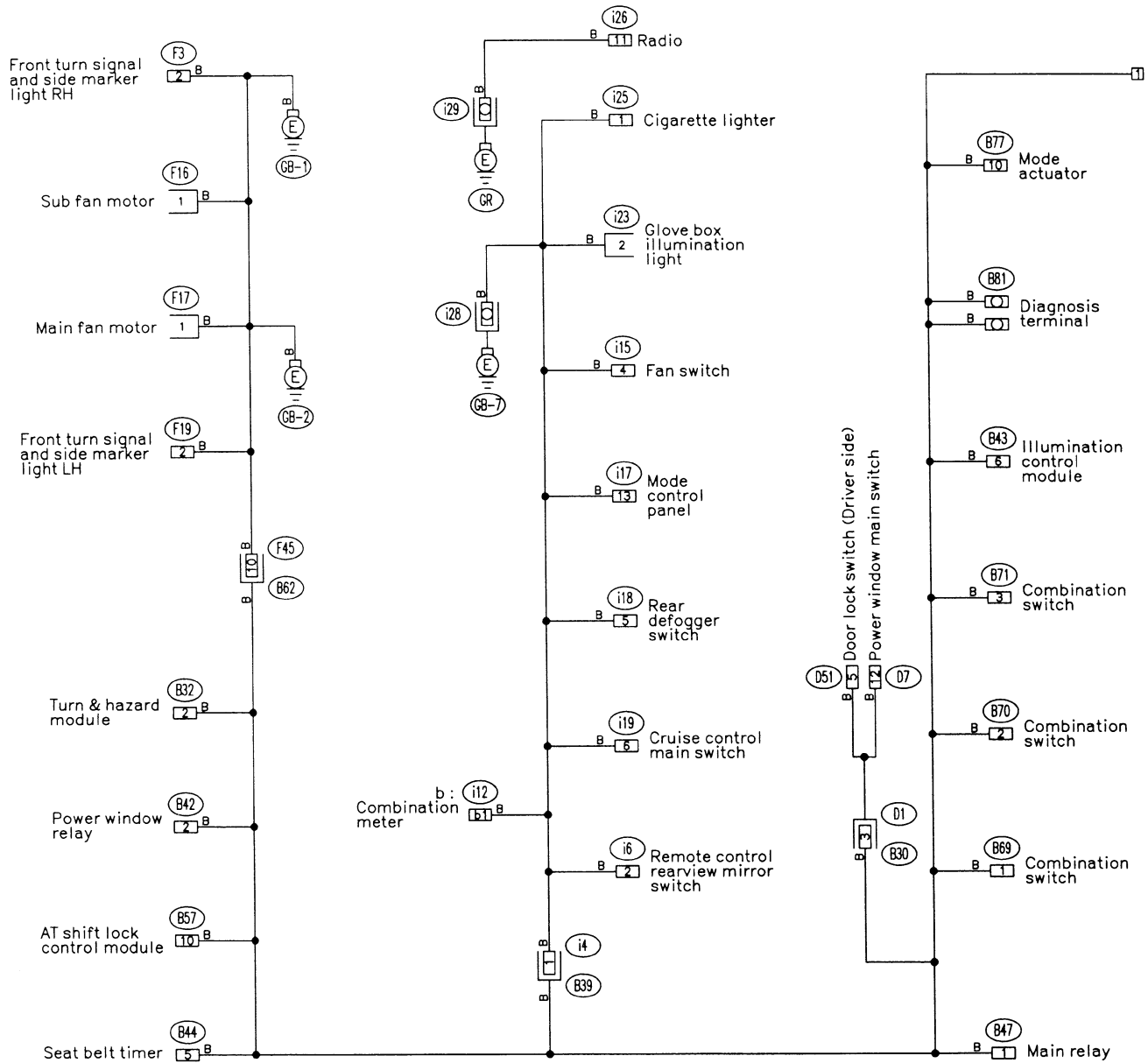

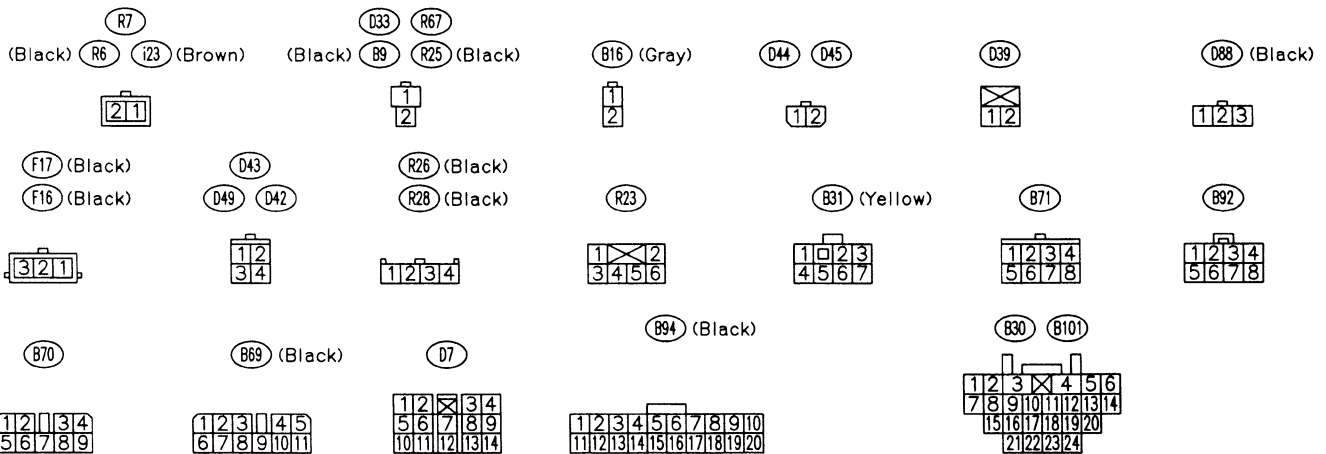
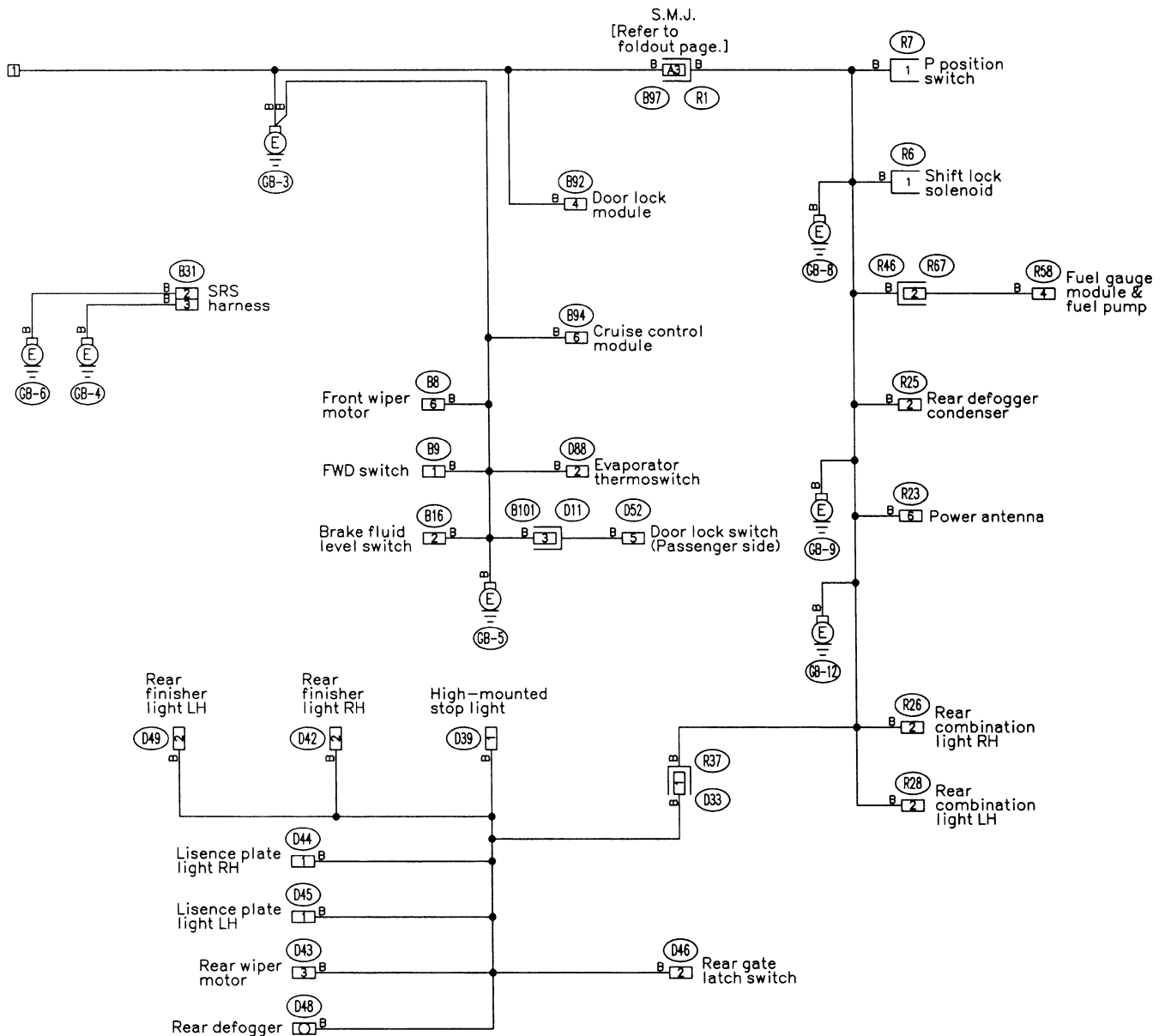

6. Wiring Diagram

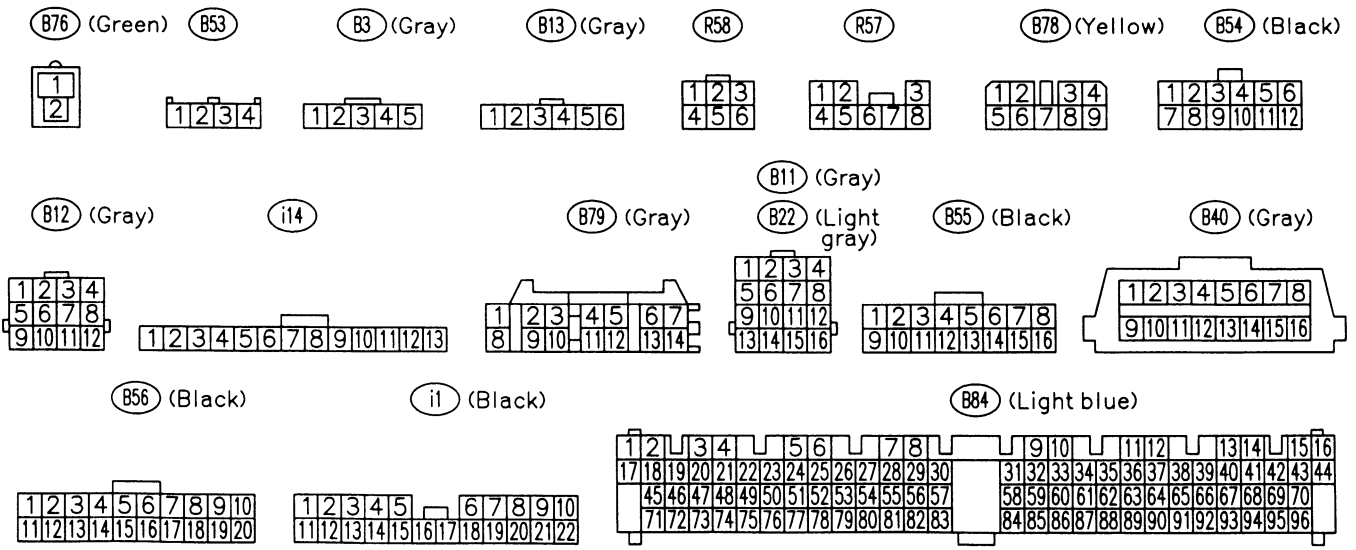
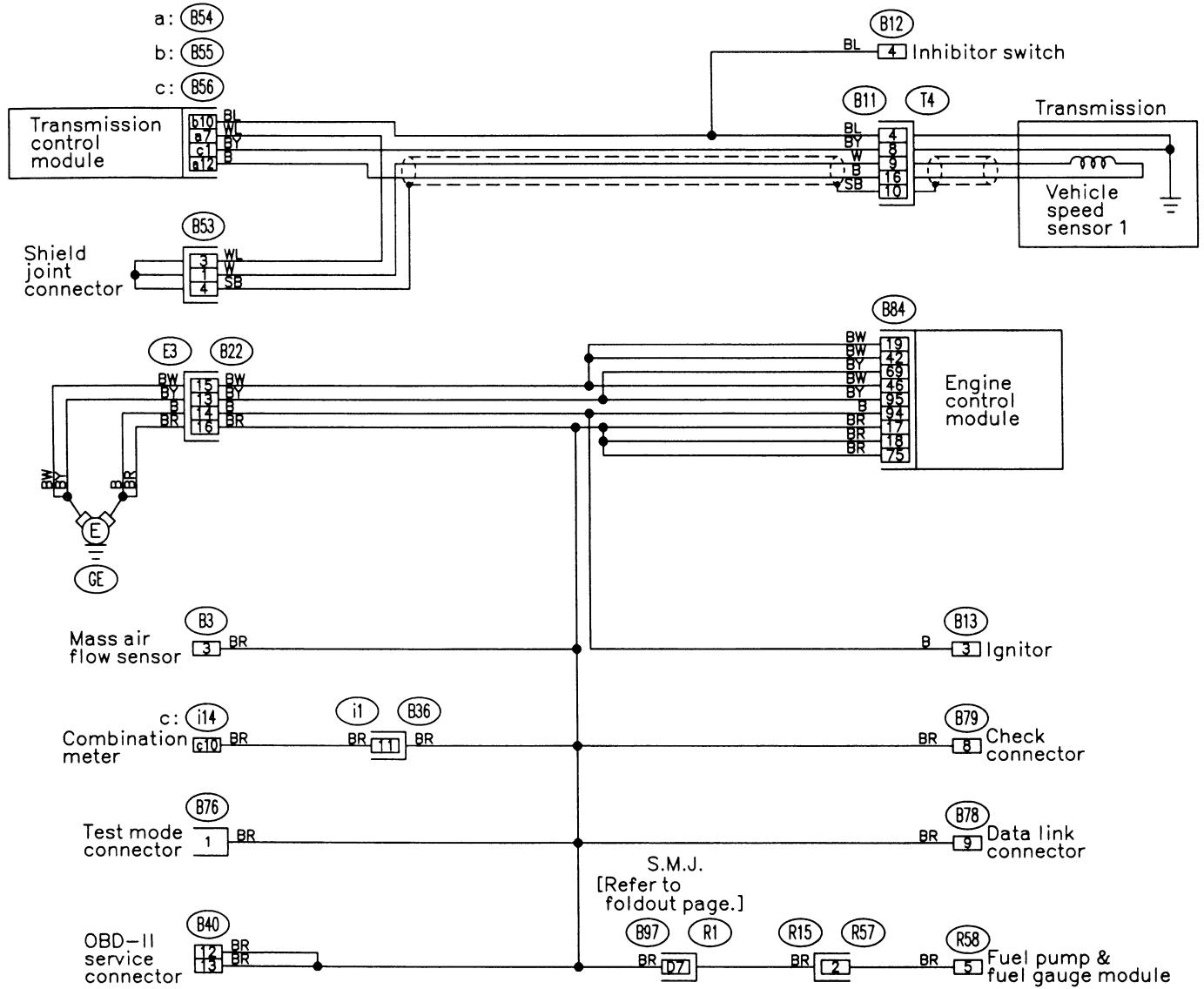



3. AIR CONDITIONING SYSTEM

● RHD model

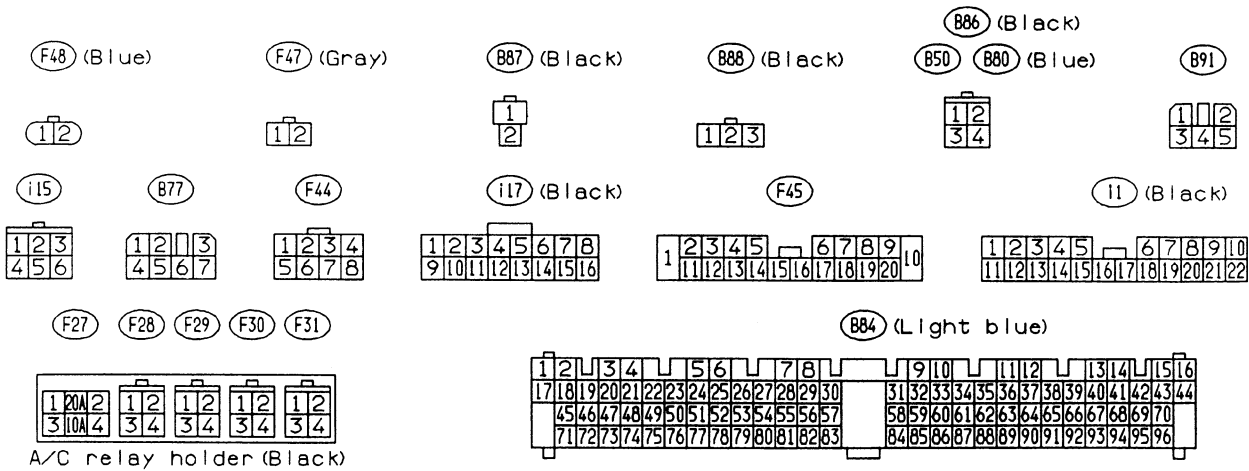
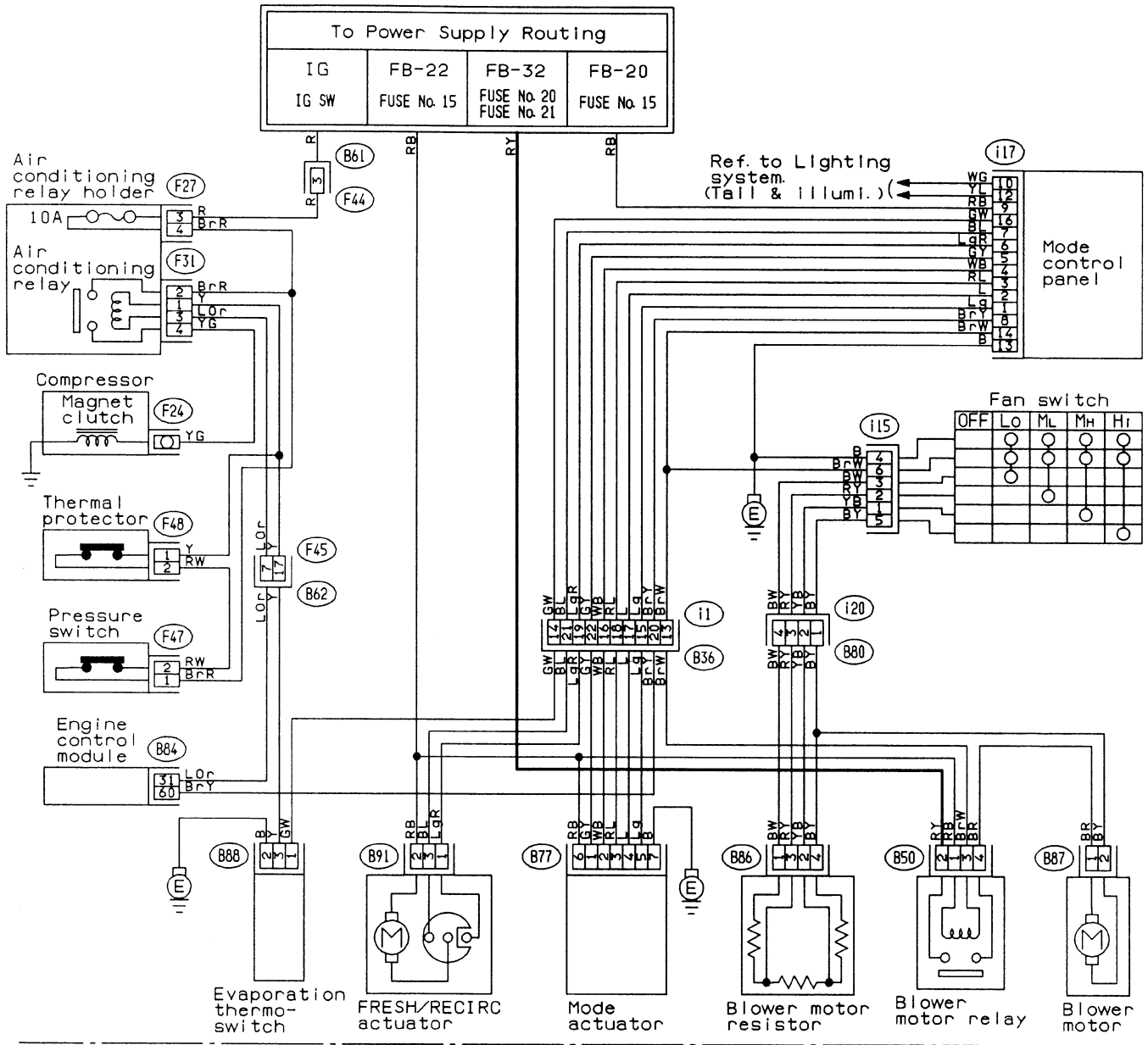



4. ANTI-LOCK BRAKE SYSTEM

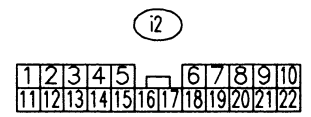
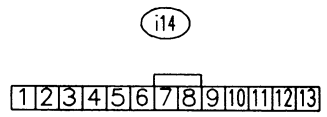
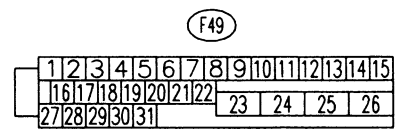
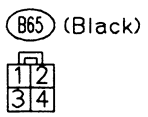
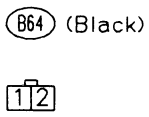
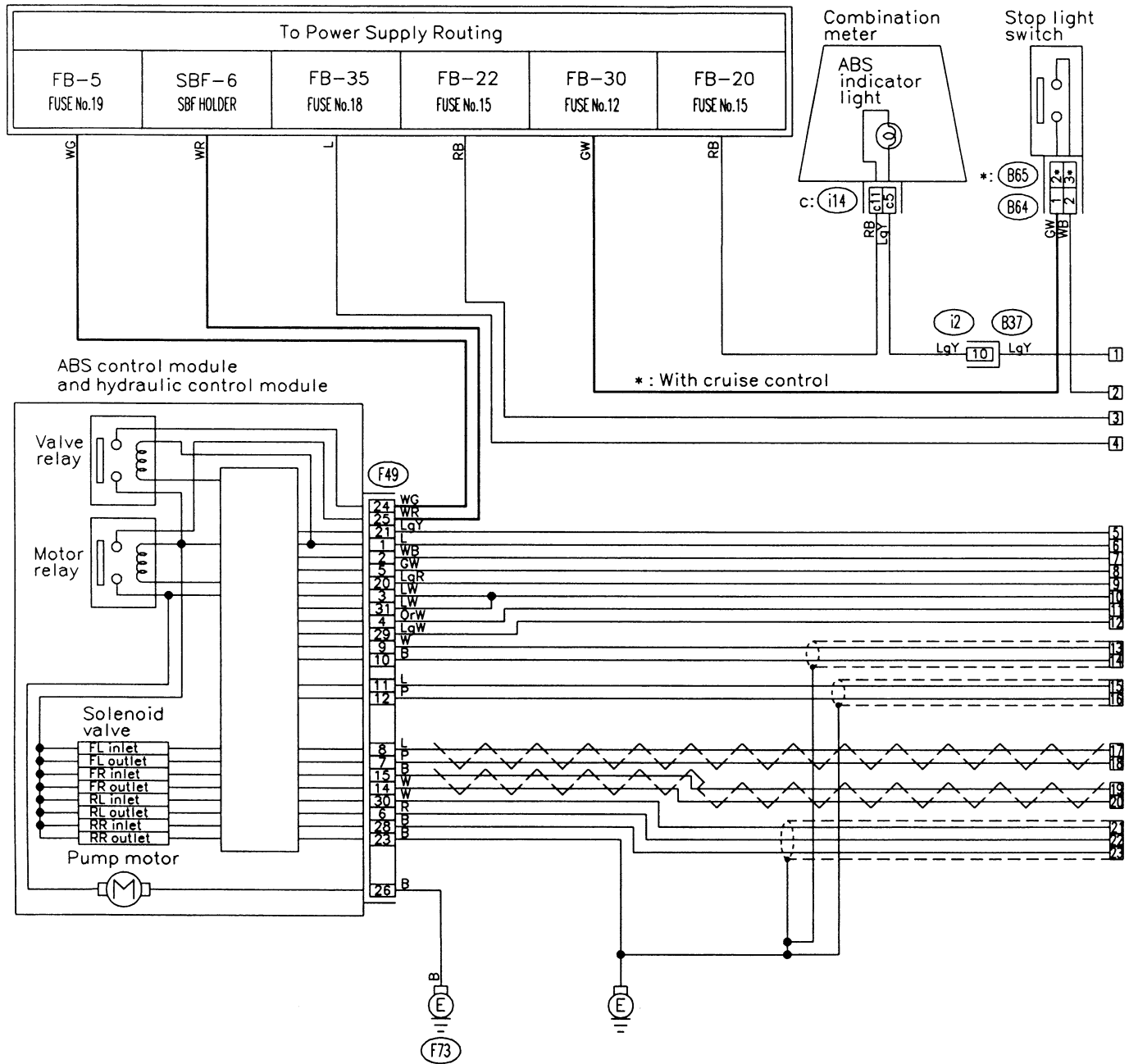

6. Wiring Diagram

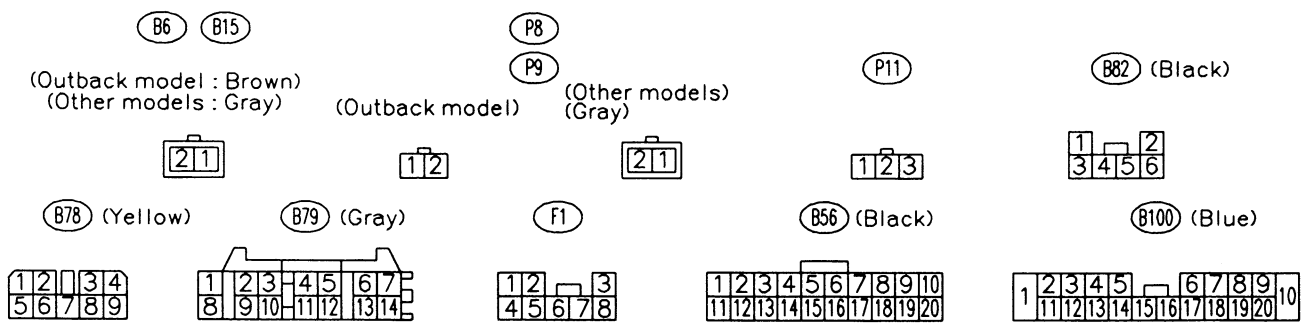
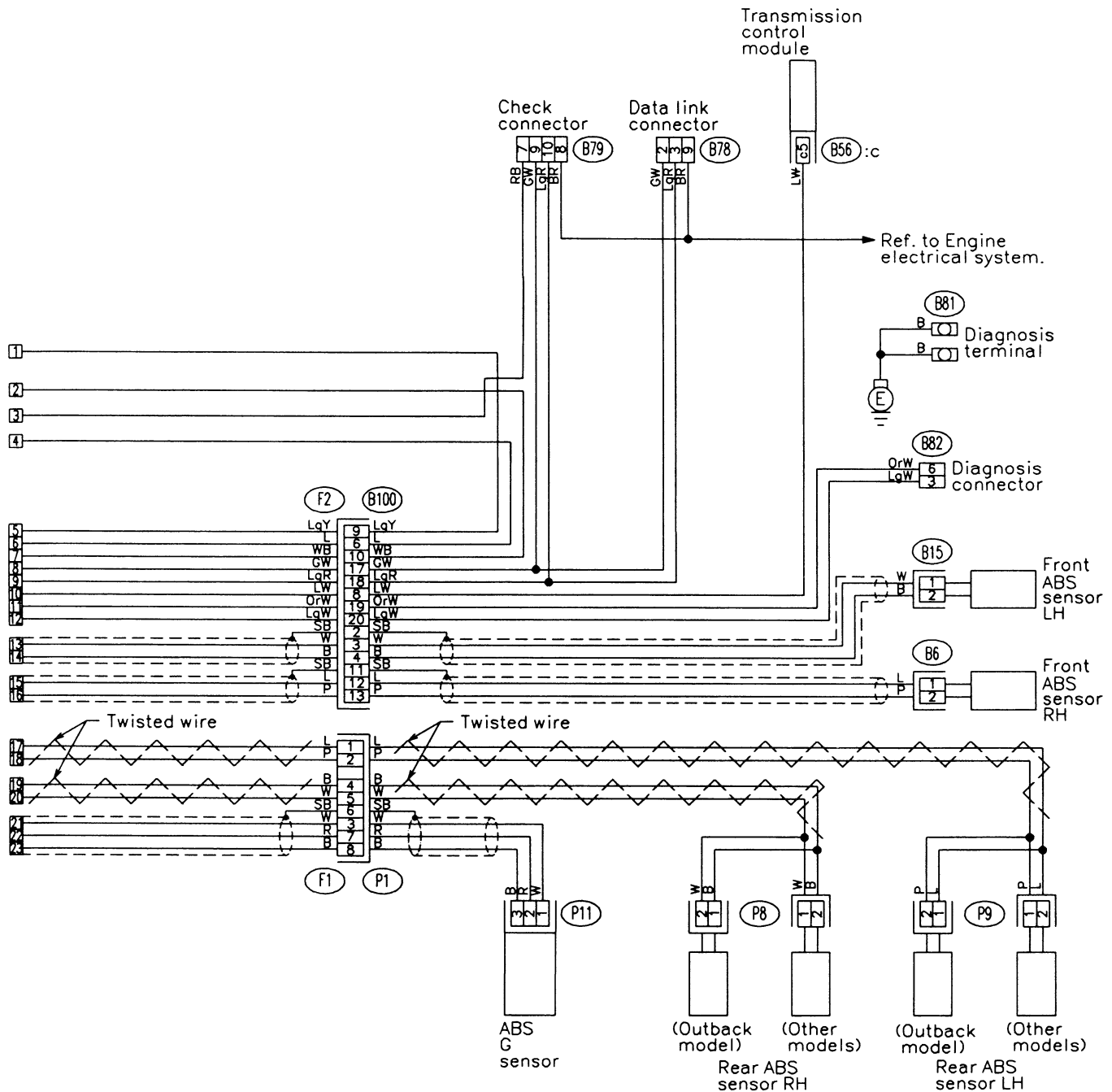

5. AT CONTROL SYSTEM

● LHD model

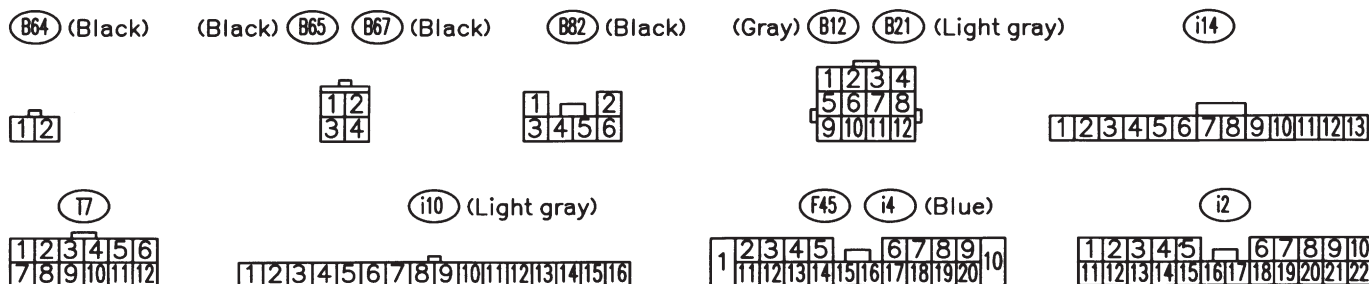
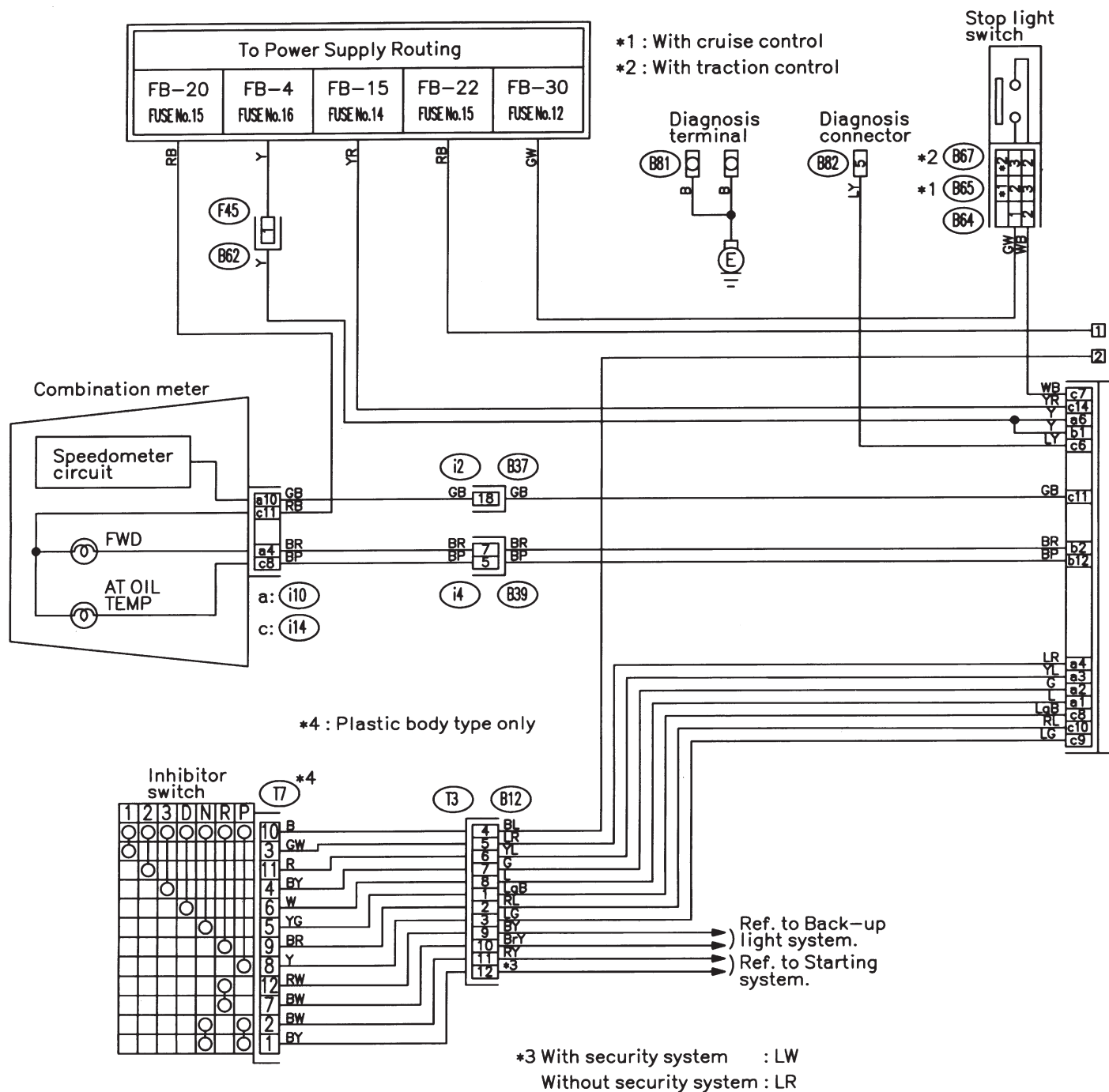

6. Wiring Diagram

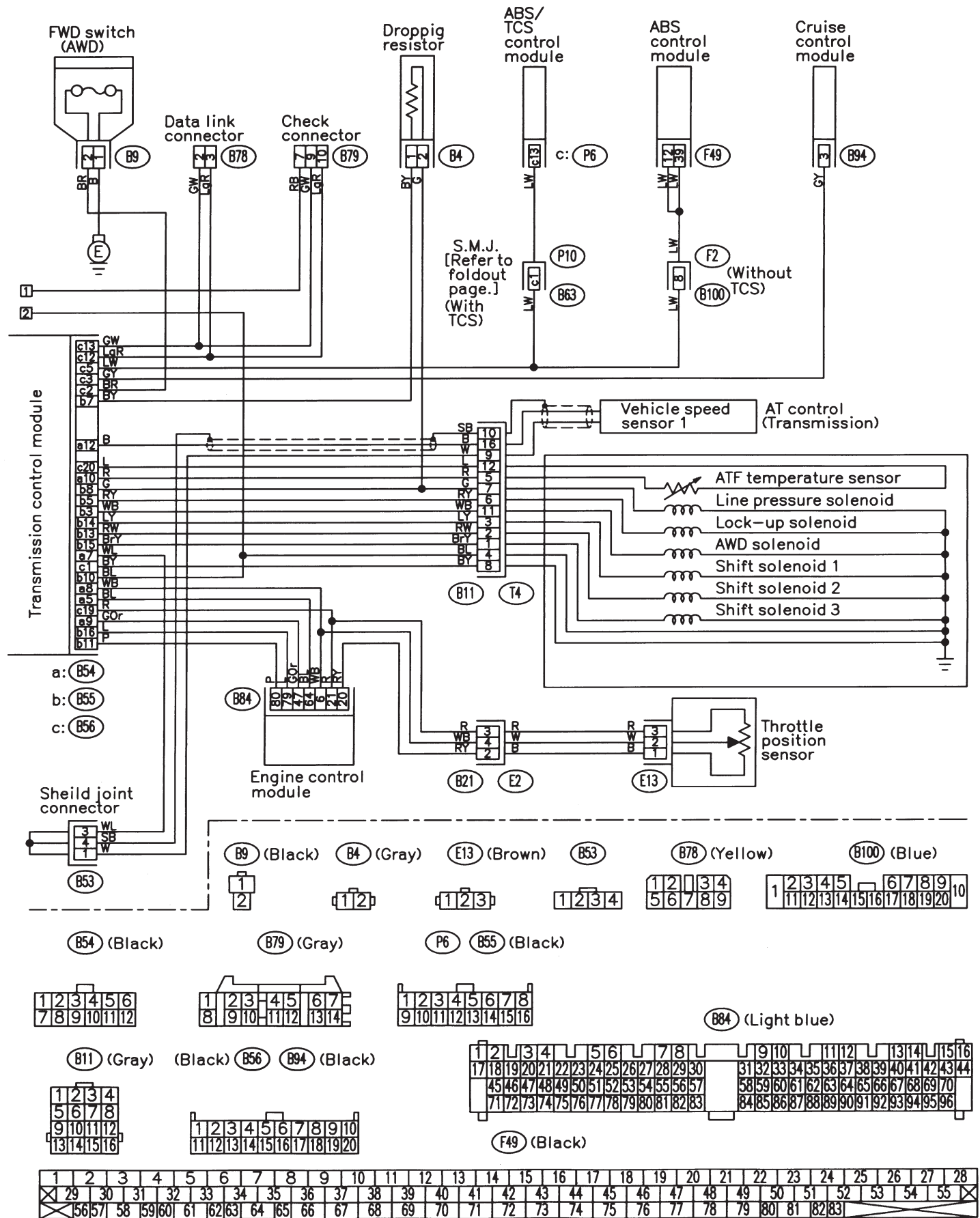

5. AT CONTROL SYSTEM

● RHD model

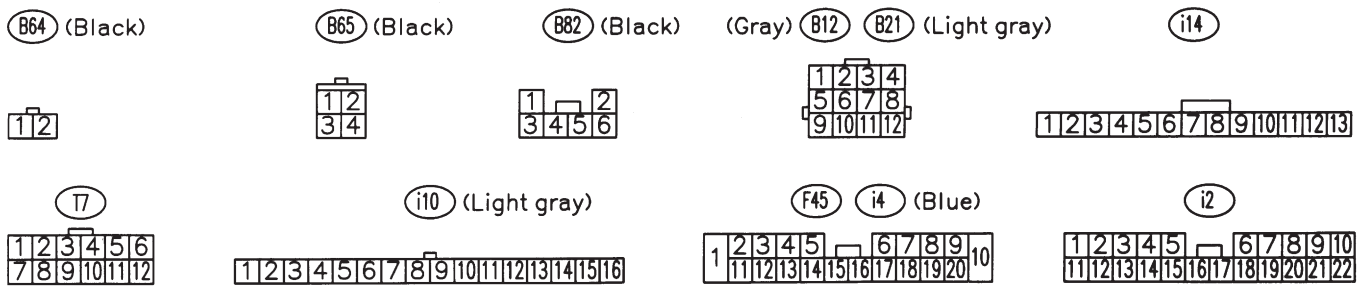
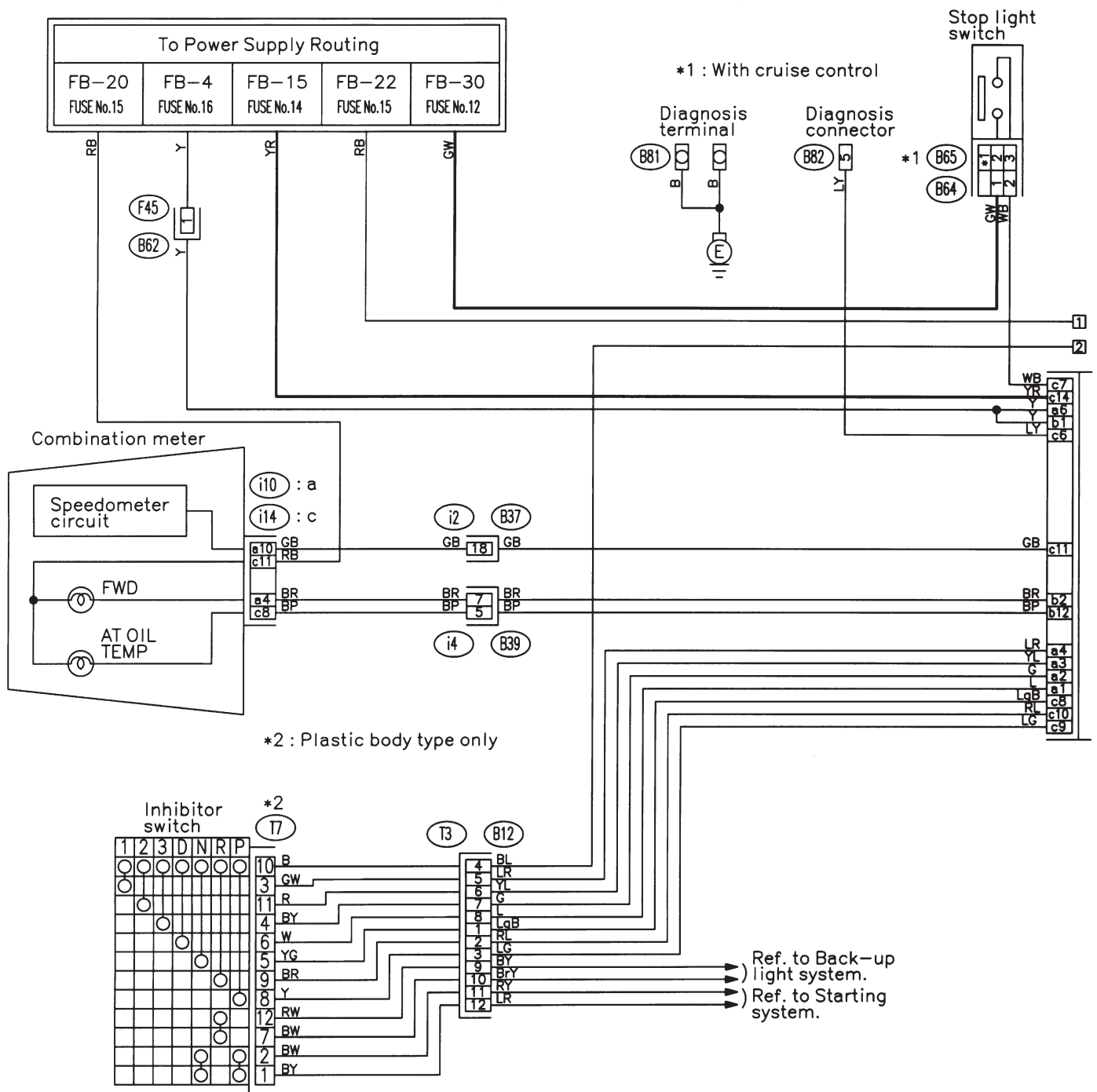

6. Wiring Diagram

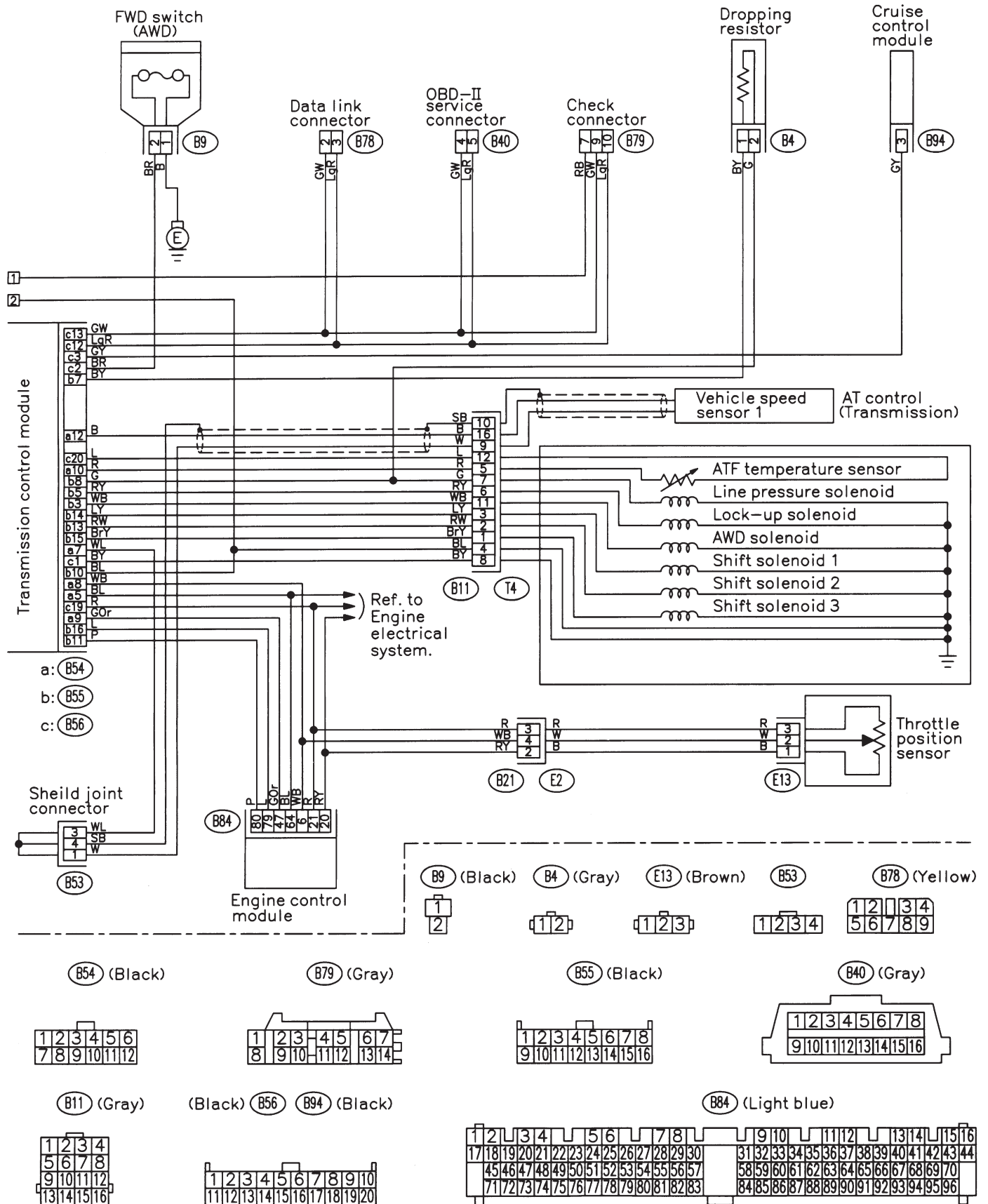

6. AT SHIFT LOCK SYSTEM

● LHD model

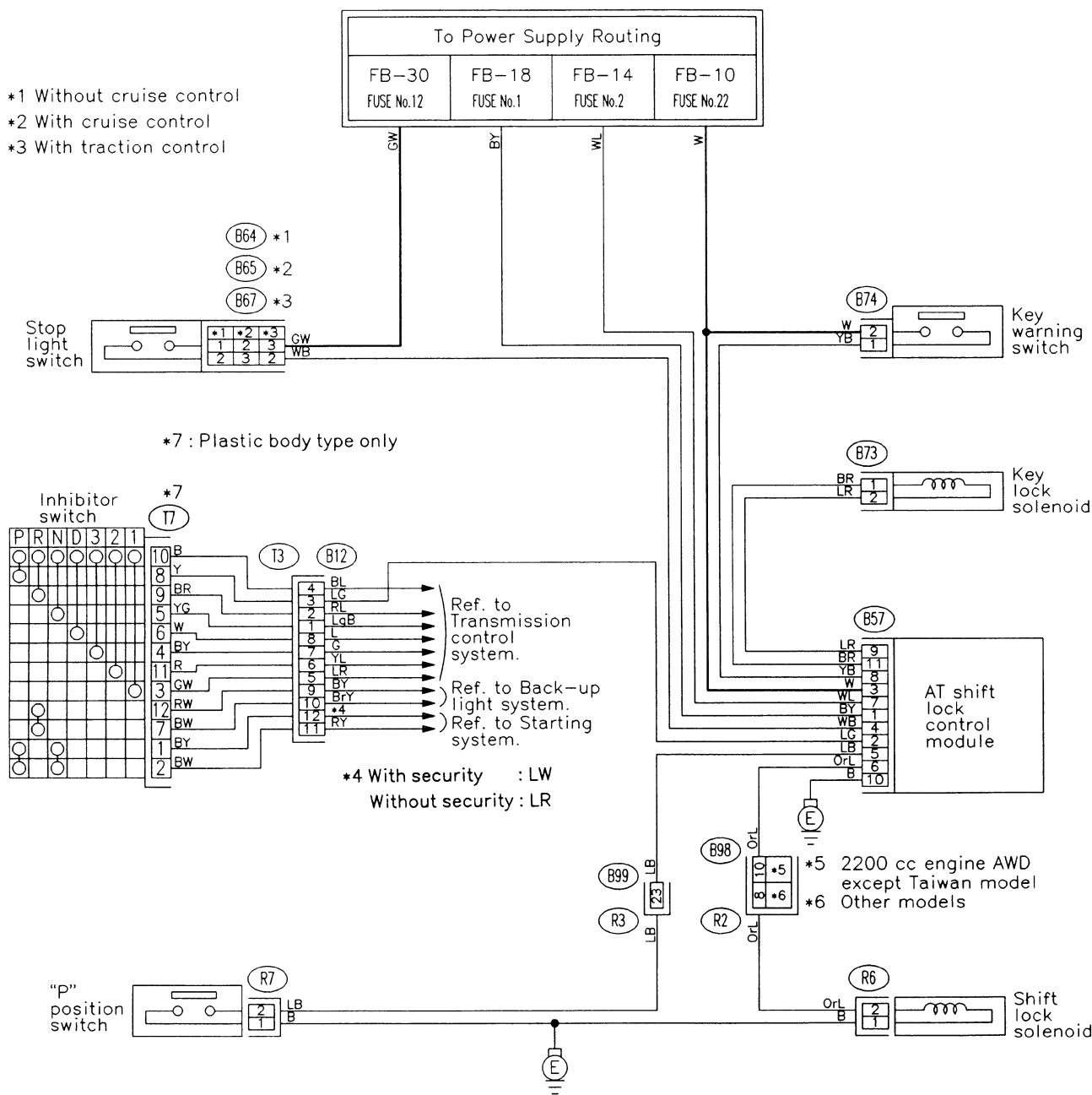

- \*1 Without cruise control
- \*2 With cruise control
- \*3 With traction control

\*7 : Plastic body type only

\*4 With security : LW  
Without security : LR

- \*5 2200 cc engine AWD except Taiwan model
- \*6 Other models

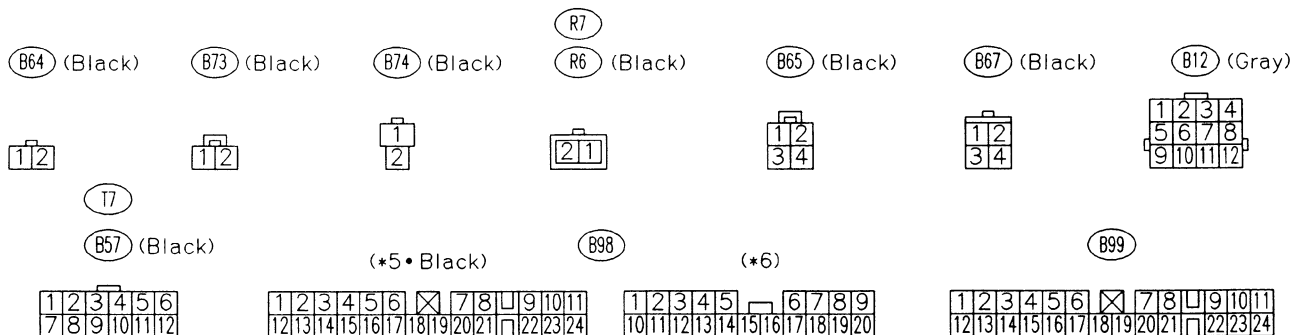

6. AT SHIFT LOCK SYSTEM

● RHD model

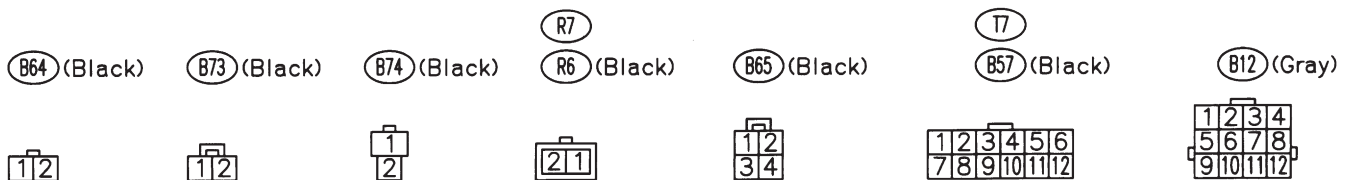
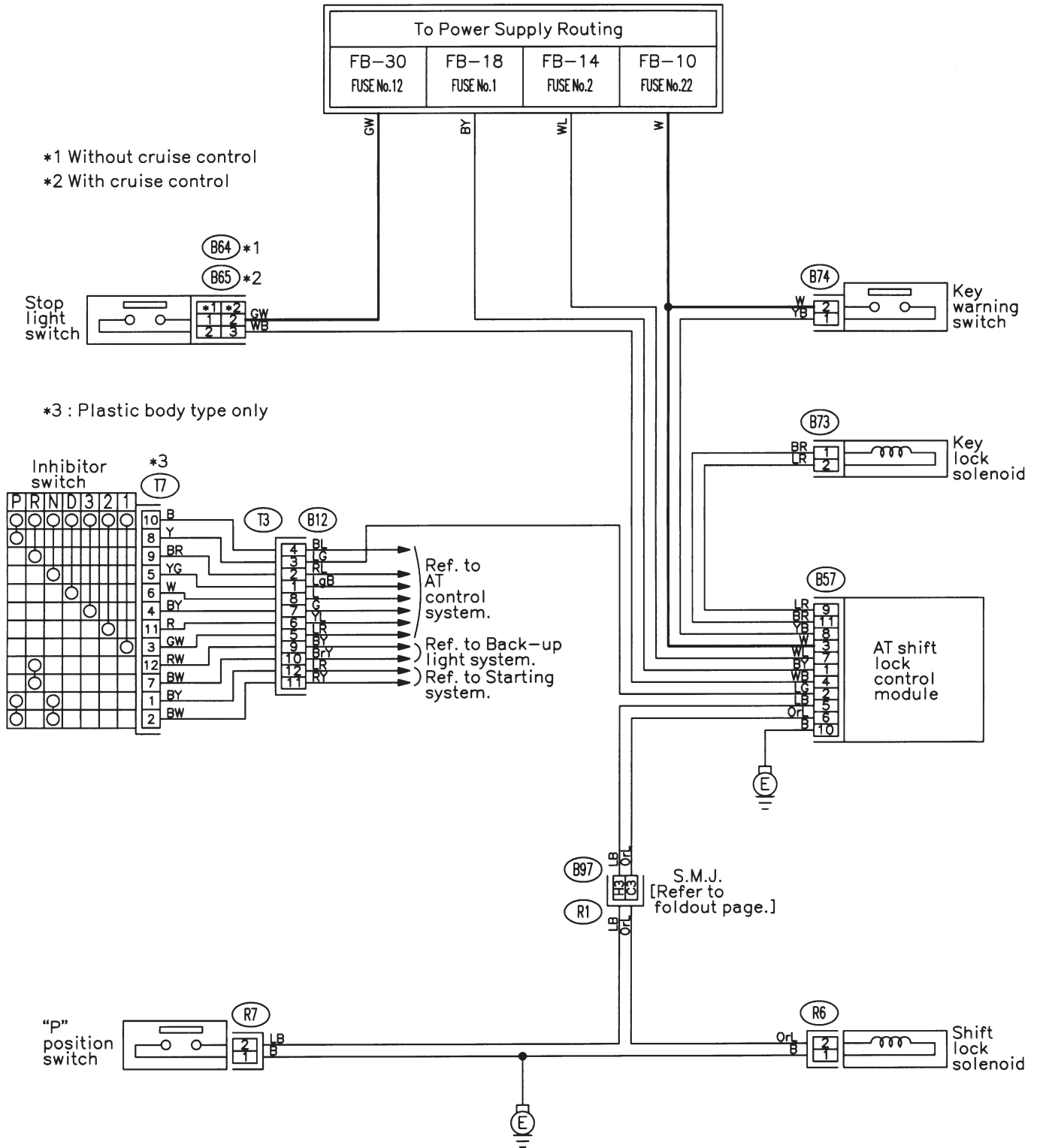



## 7. AUDIO SYSTEM

● LHD model

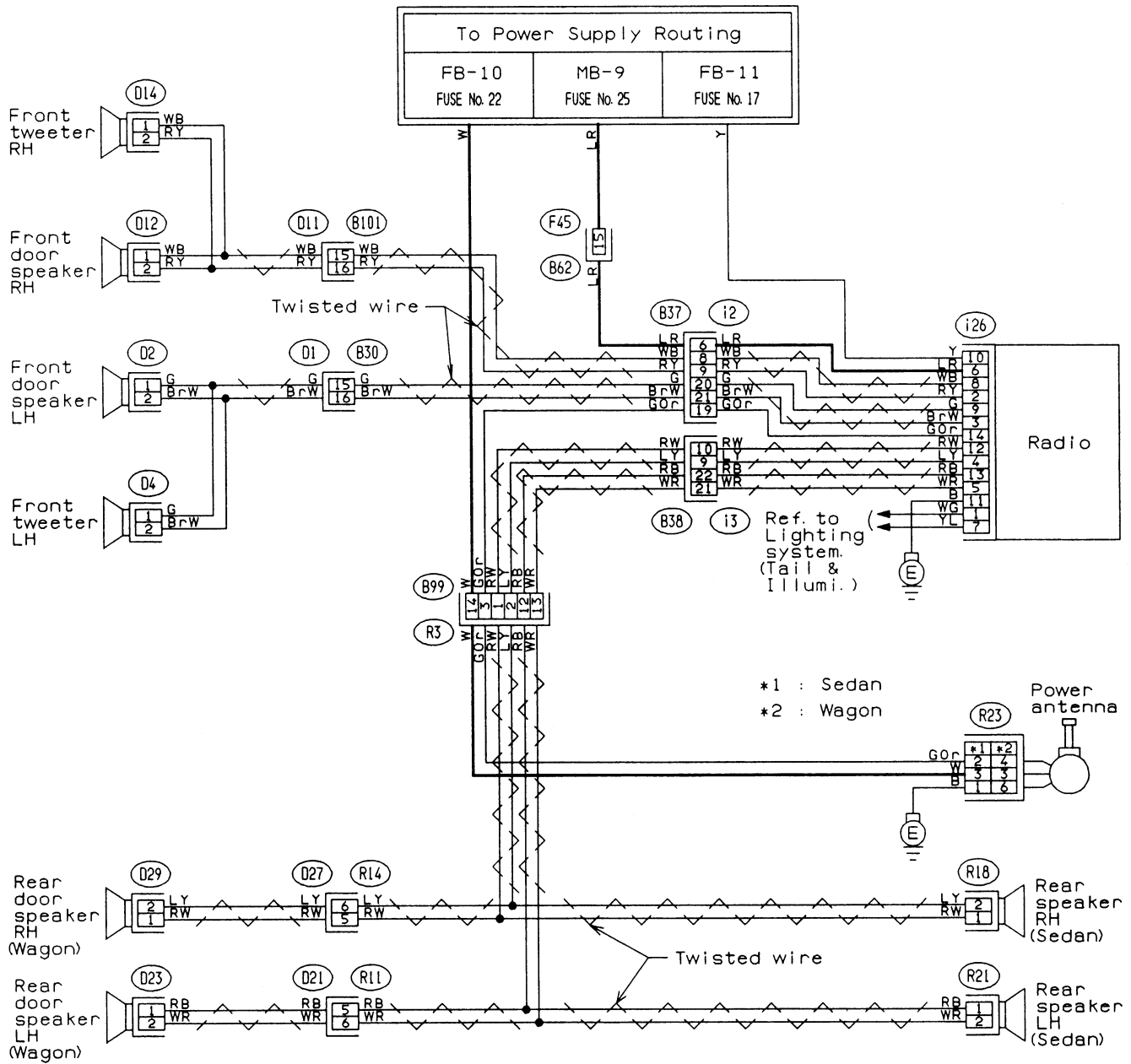

\*1 : Sedan  
\*2 : Wagon

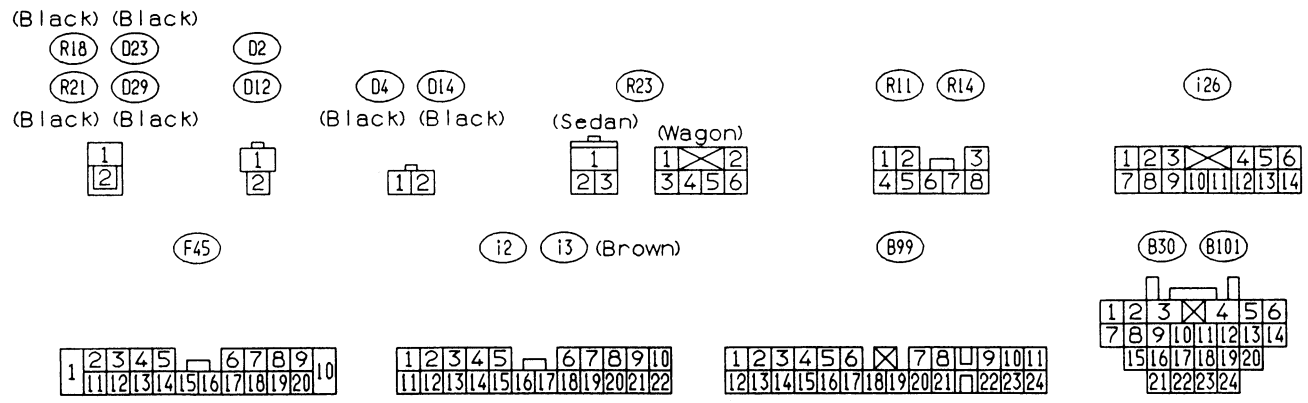



8. BACK-UP LIGHT SYSTEM

● LHD model

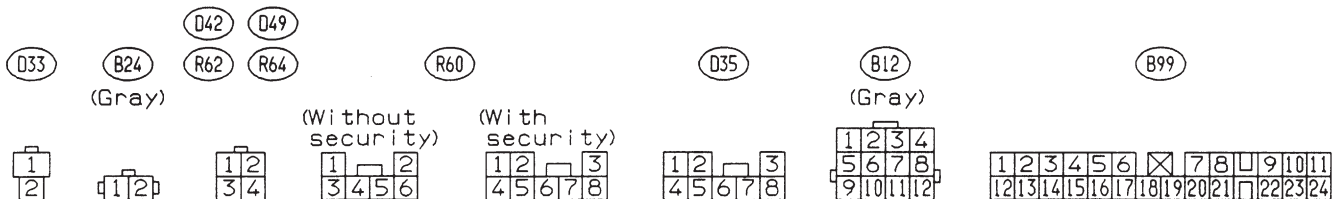
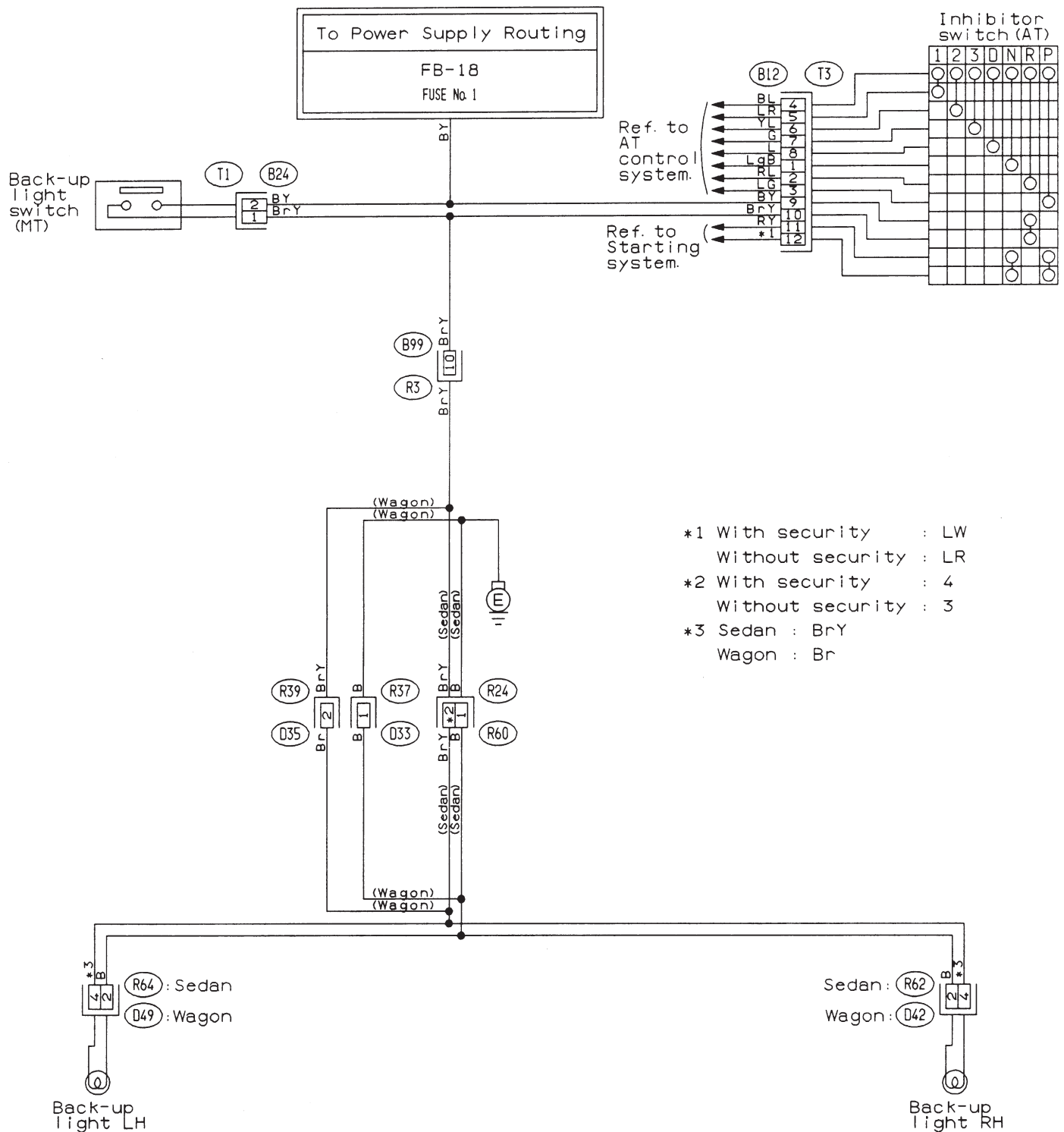

8. BACK-UP LIGHT SYSTEM

● RHD model

\* : Plastic body type only

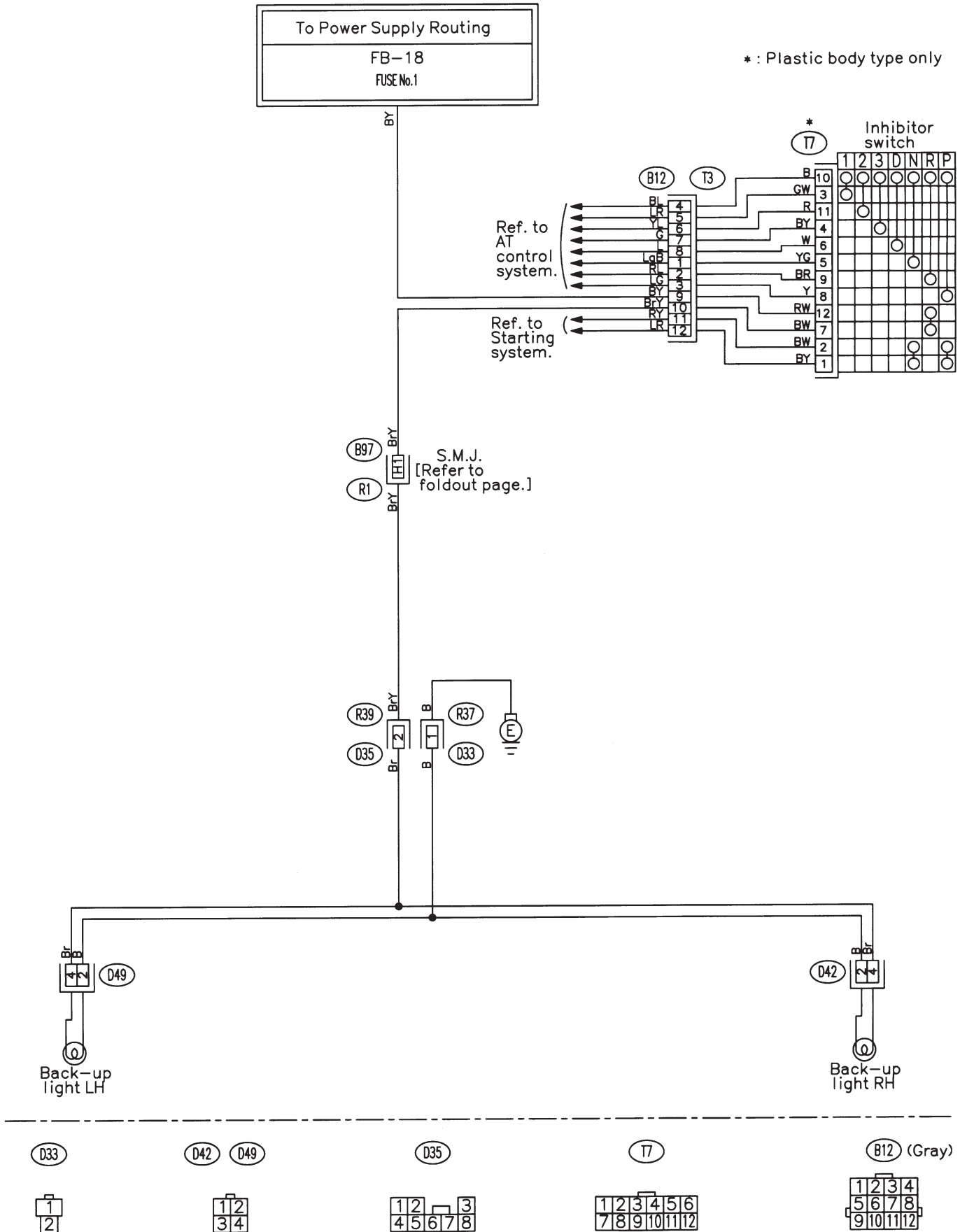

9. CHARGE WARNING SYSTEM

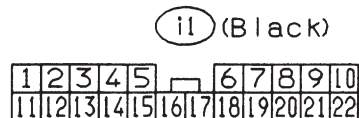
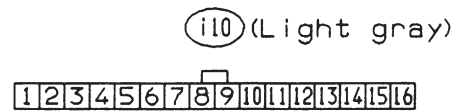
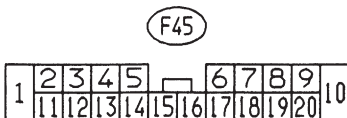
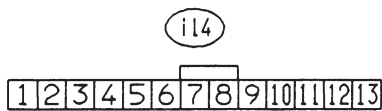
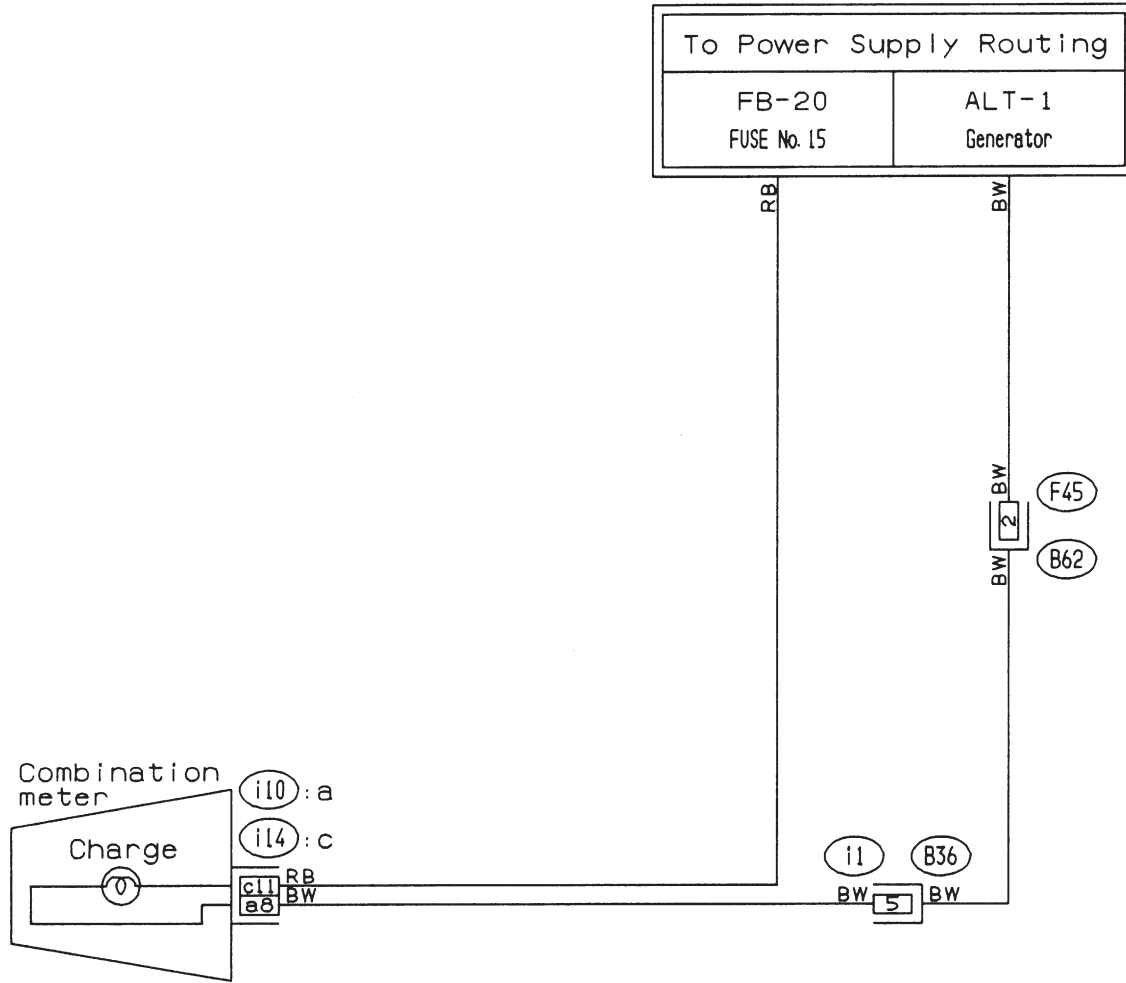

BU02-01

10. COMBINATION METER

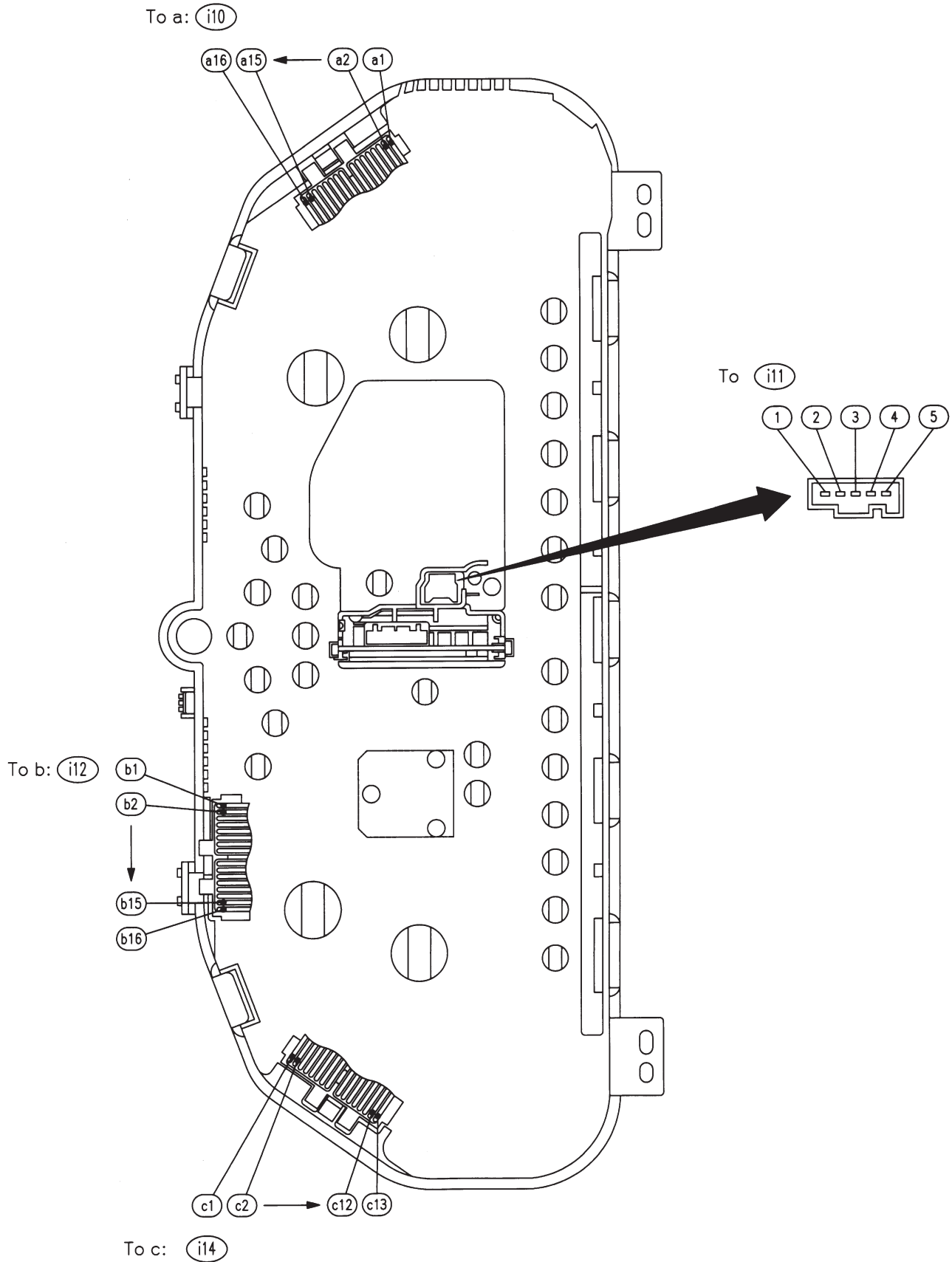

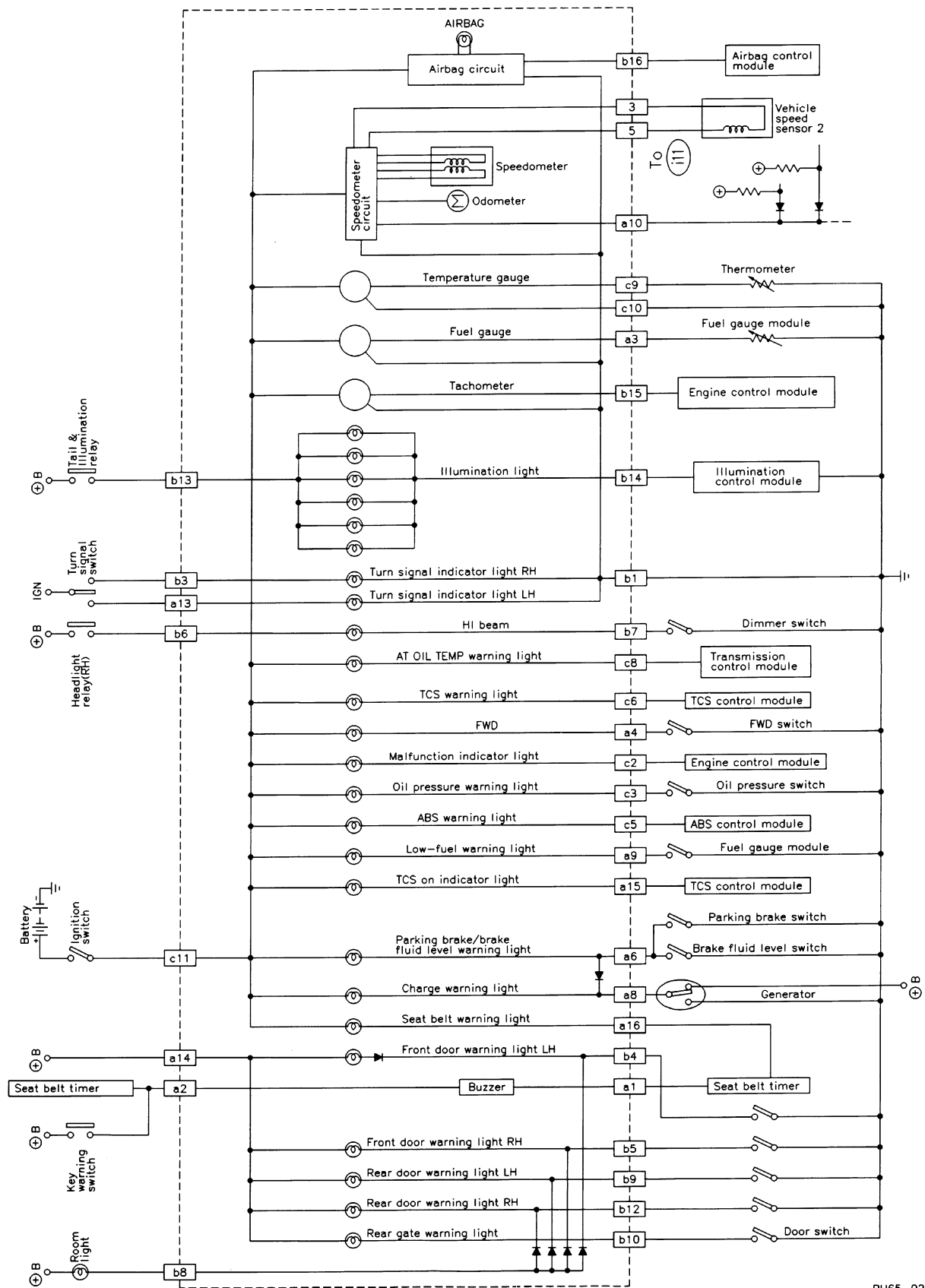

BU65-02B

11. CRUISE CONTROL SYSTEM

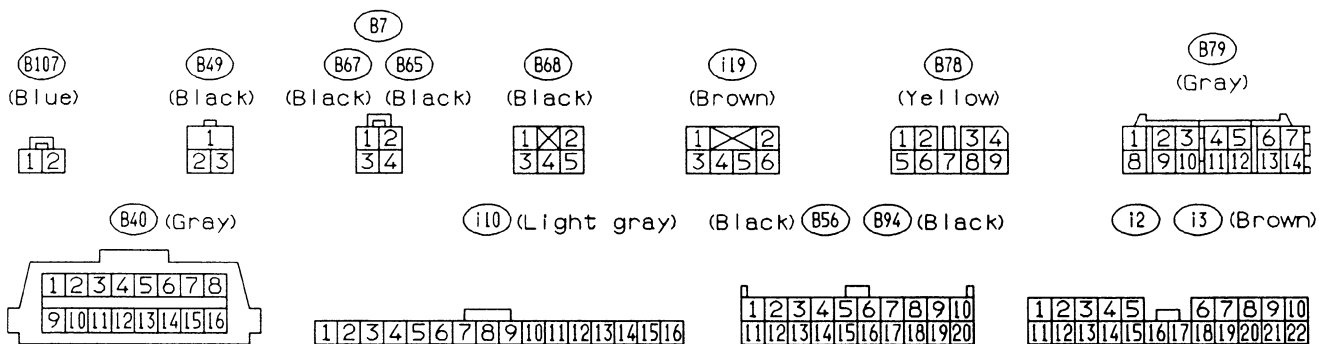
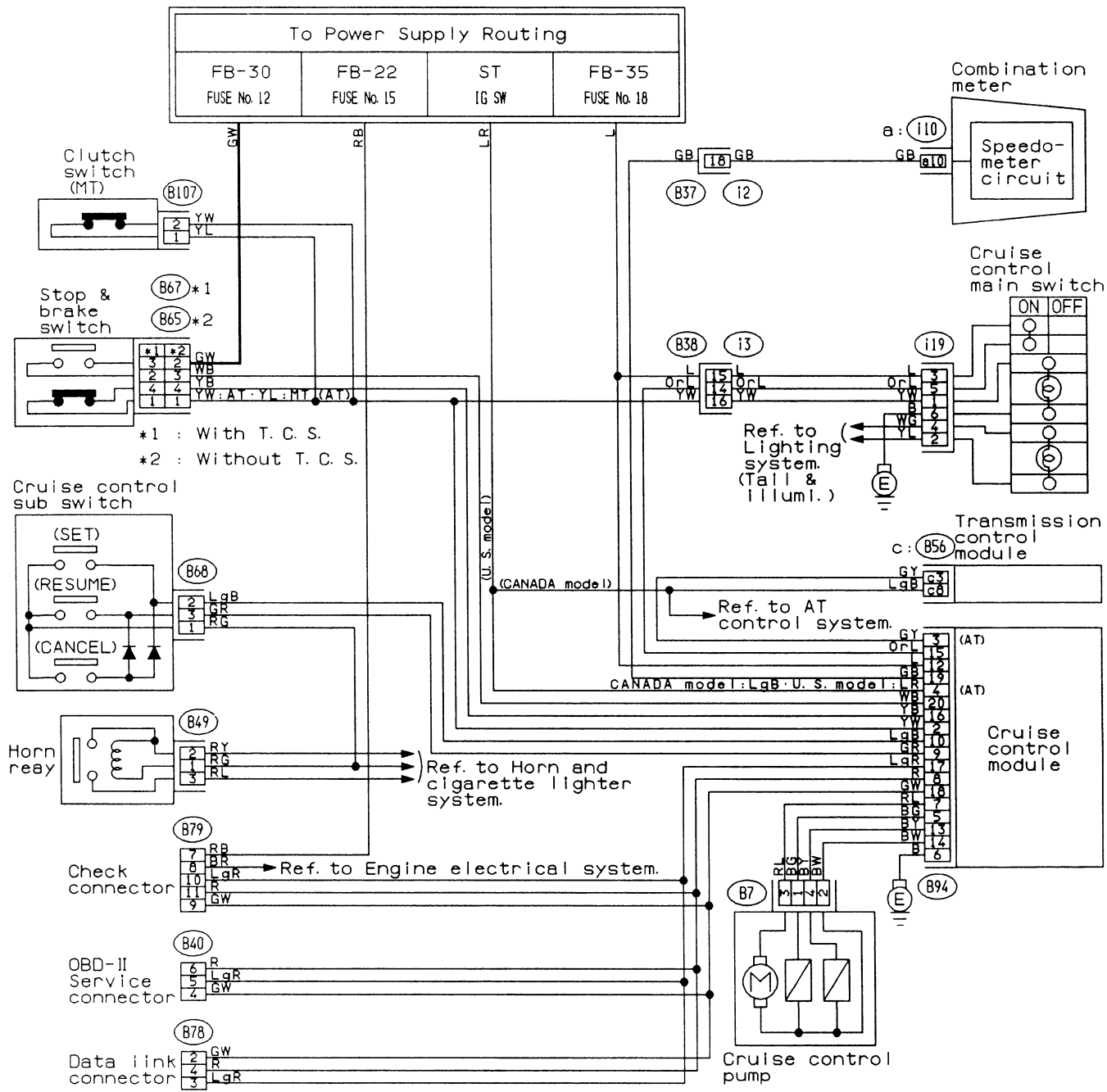



12. DOOR LOCK SYSTEM

● LHD model

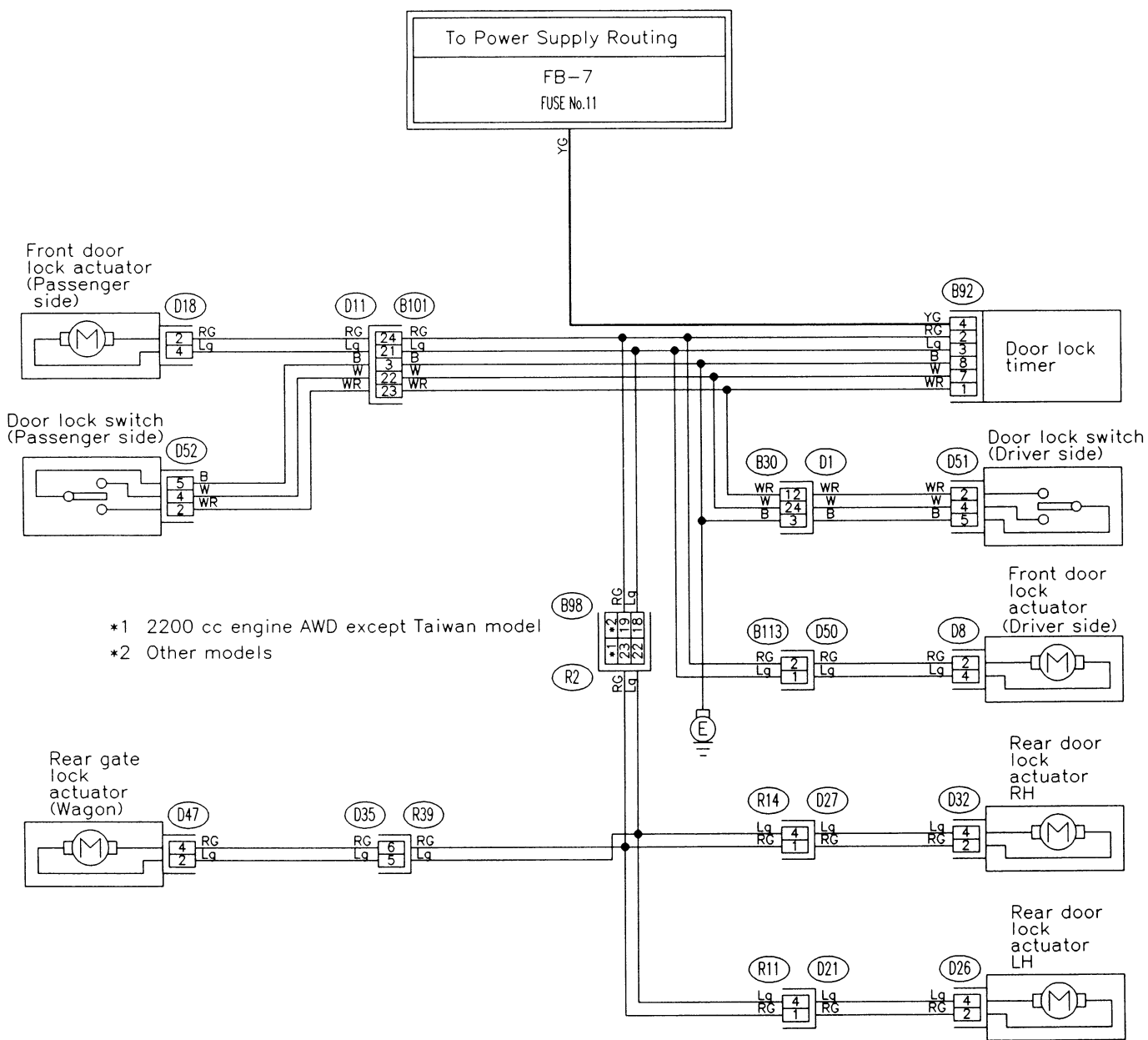

- \*1 2200 cc engine AWD except Taiwan model
- \*2 Other models

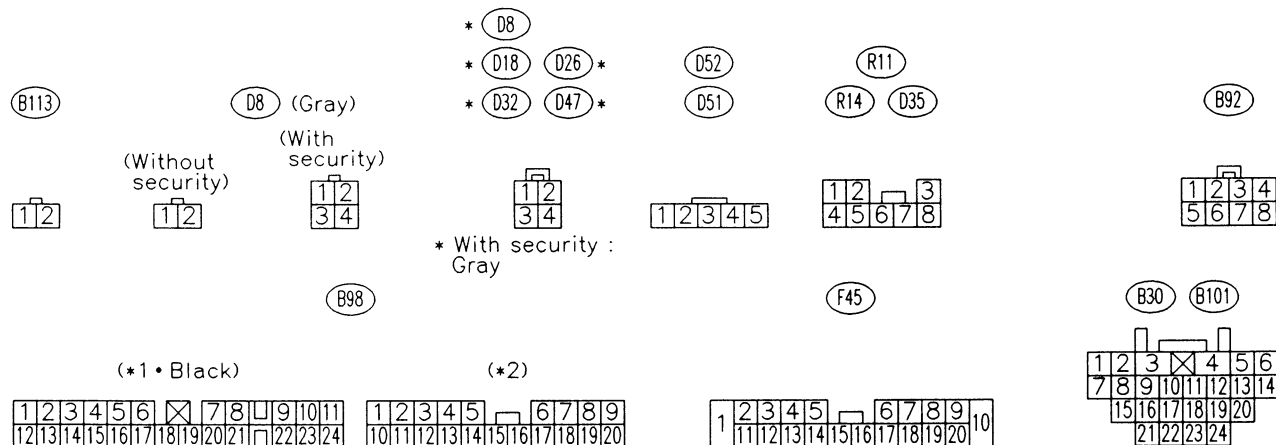

12. DOOR LOCK SYSTEM

● RHD model

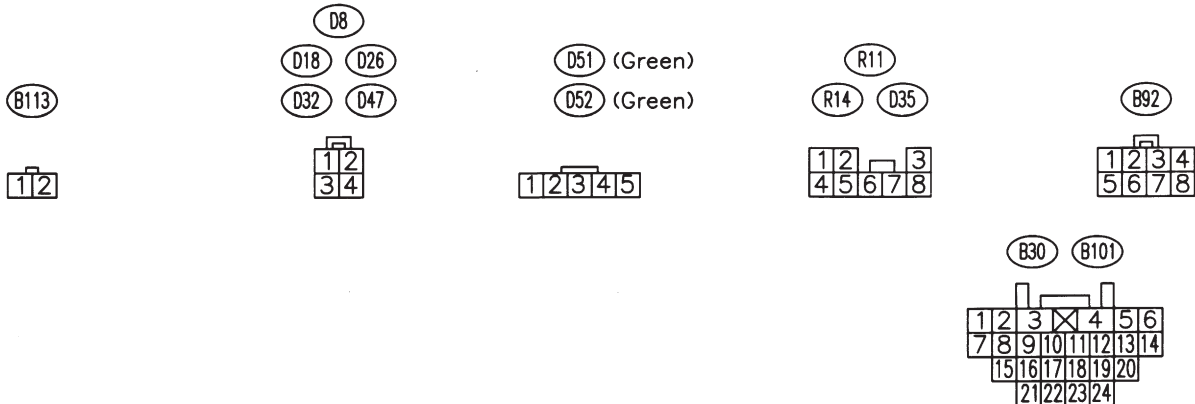
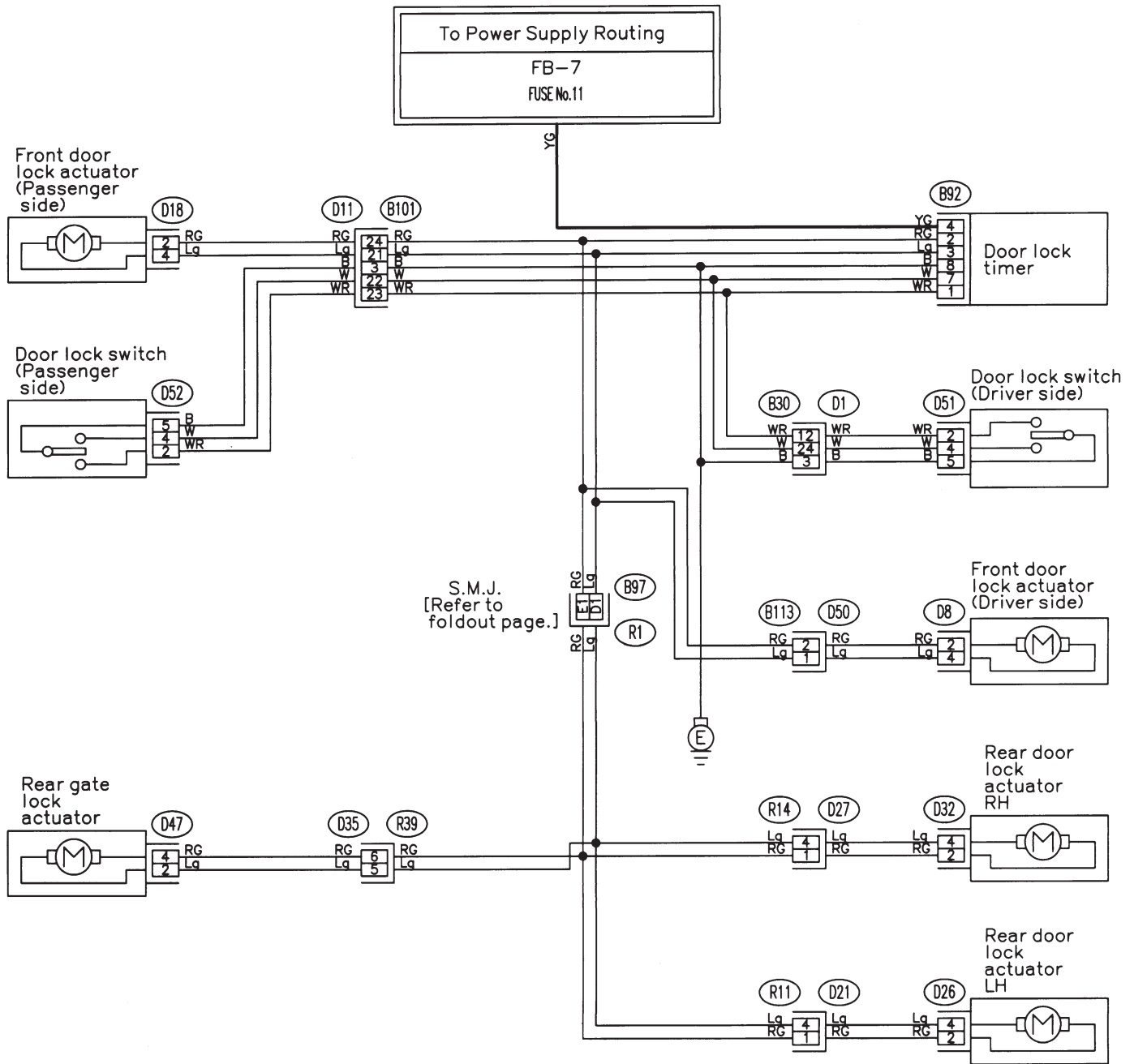



6. Wiring Diagram

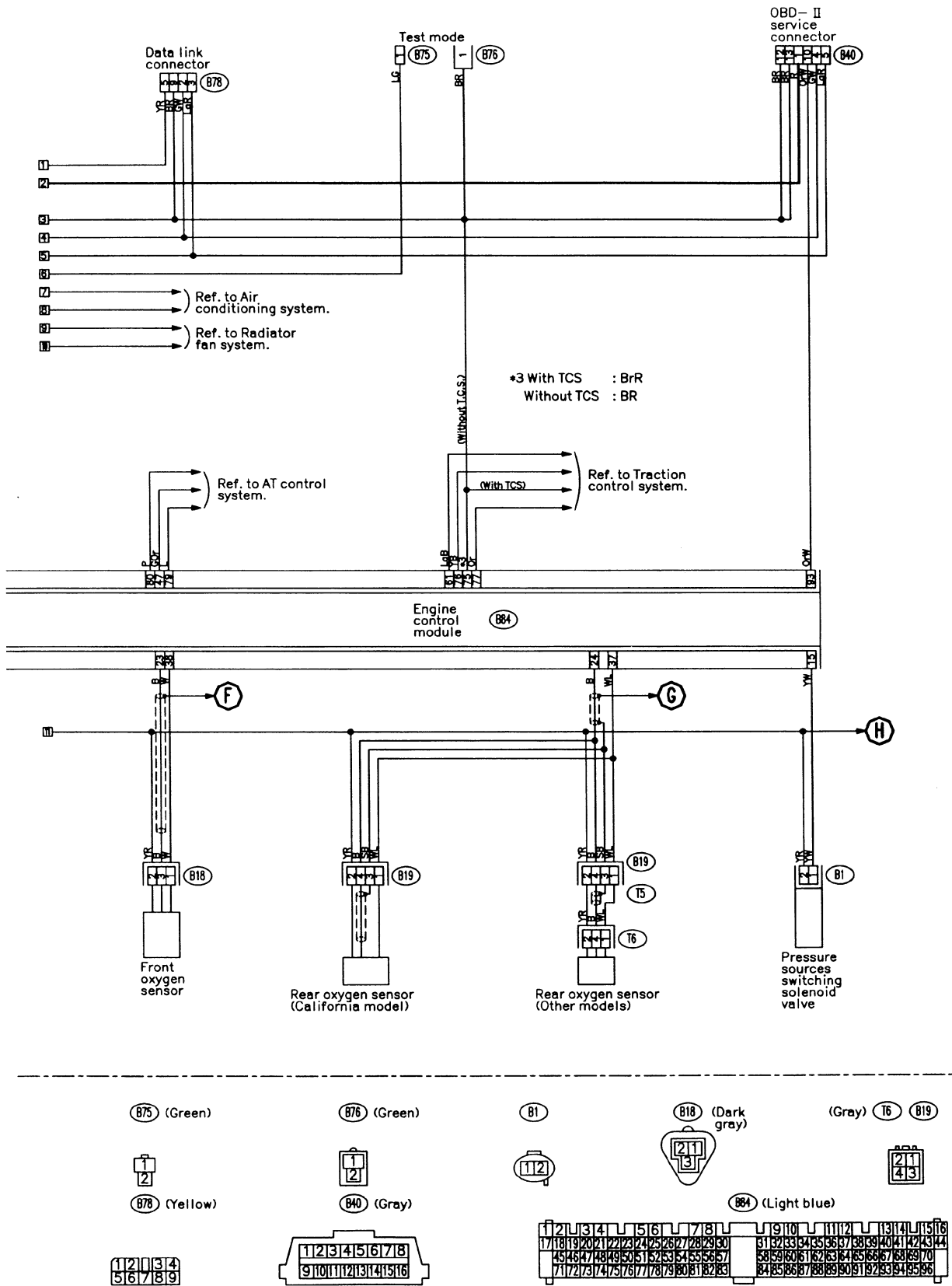

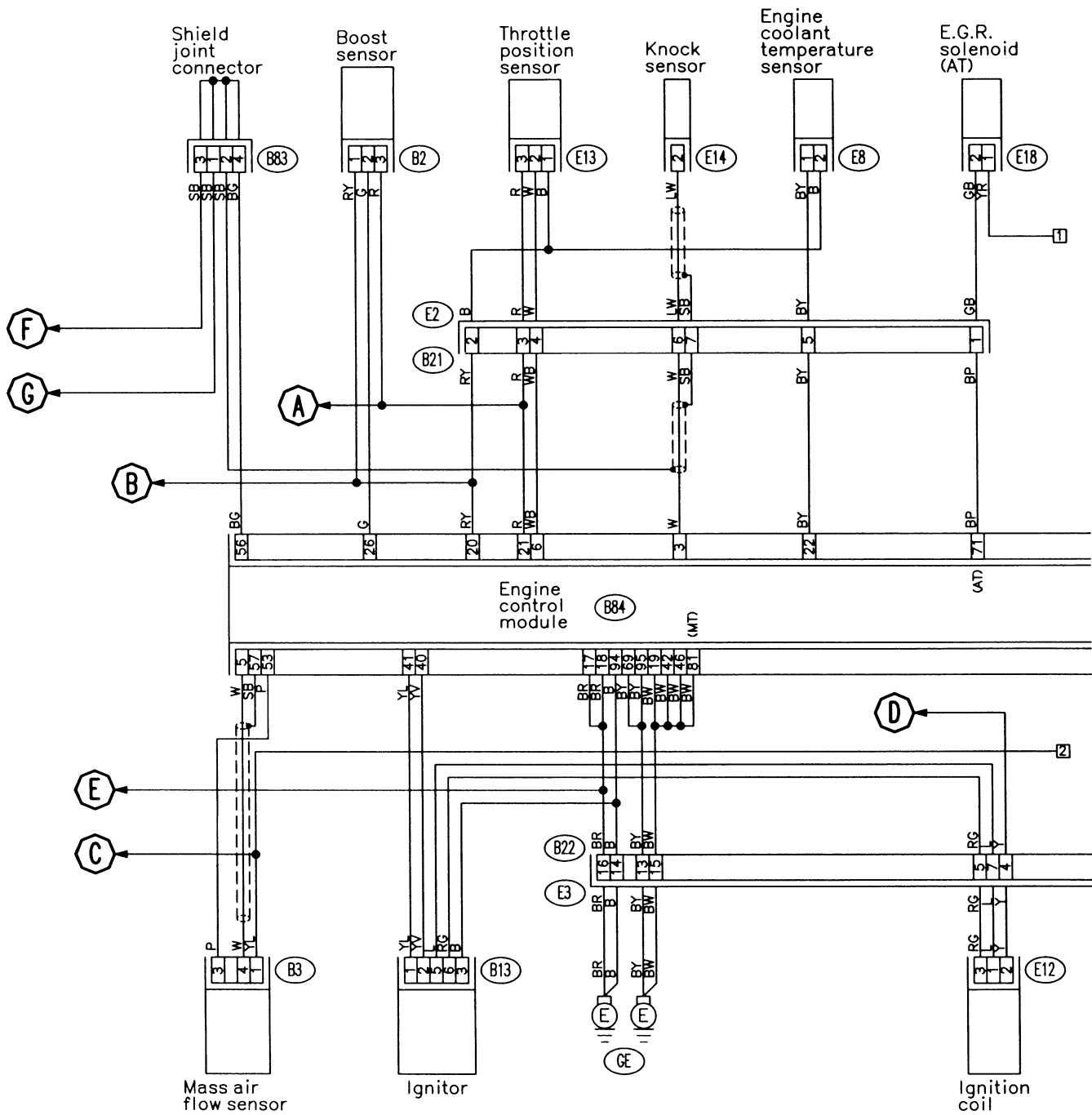

- Legend for connector types and wire colors:
- (Brown) (E18) (E8) (Brown) (Black) (B2) (E13) (Brown) (E12) (Gray) (B83)
  - (B3) (Gray) (B13) (Gray) (B21) (Light gray) (B22) (Light gray)
- Connector types and terminal layouts:
- Connector 1: 1 2
  - Connector 2: 1 2 3
  - Connector 3: 1 2 3
  - Connector 4: 1 2 3 4
  - Connector 5: 1 2 3 4 5
  - Connector 6: 1 2 3 4 5 6
  - Connector 7: 1 2 3 4 / 5 6 7 8 / 9 10 11 12
  - Connector 8: 1 2 3 4 / 5 6 7 8 / 9 10 11 12 / 13 14 15 16

6. Wiring Diagram

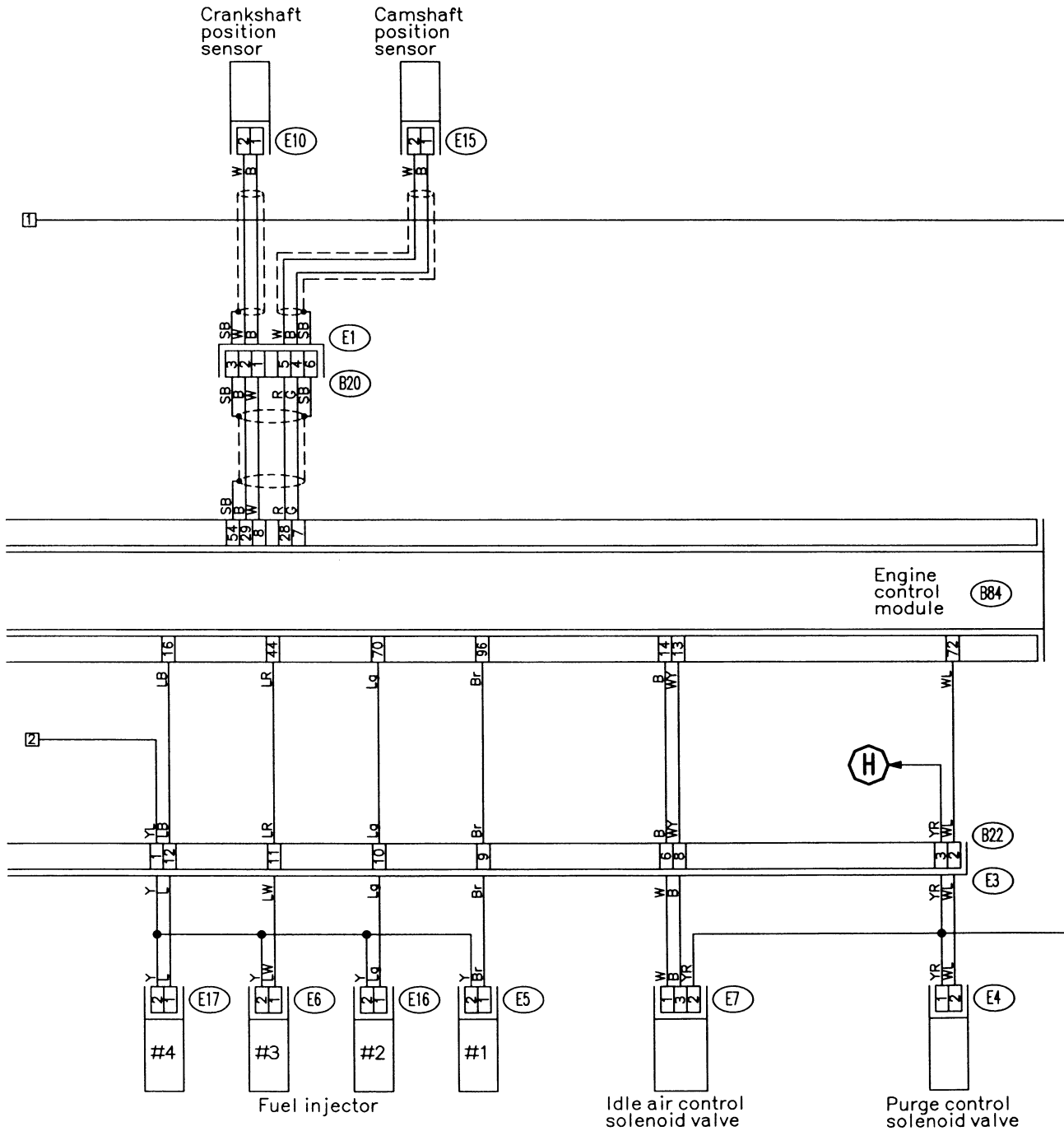

- (E15) (Dark gray)      (Light gray)      (E5)      (E16) (Light gray)
- (E10) (Gray)          (Dark gray)      (E6)      (E17) (Dark gray)
- 
- (E4) (Blue)          (E7) (Gray)      (B20) (Light gray)
- 

(B84) (Light blue)

1	2	3	4	5	6	7	8	9	10	11	12	13	14	15	16																																				
17	18	19	20	21	22	23	24	25	26	27	28	29	30	31	32	33	34	35	36	37	38	39	40	41	42	43	44																								
45	46	47	48	49	50	51	52	53	54	55	56	57	58	59	60	61	62	63	64	65	66	67	68	69	70	71	72	73	74	75	76	77	78	79	80	81	82	83	84	85	86	87	88	89	90	91	92	93	94	95	96

13. ENGINE ELECTRICAL SYSTEM

● LHD other models

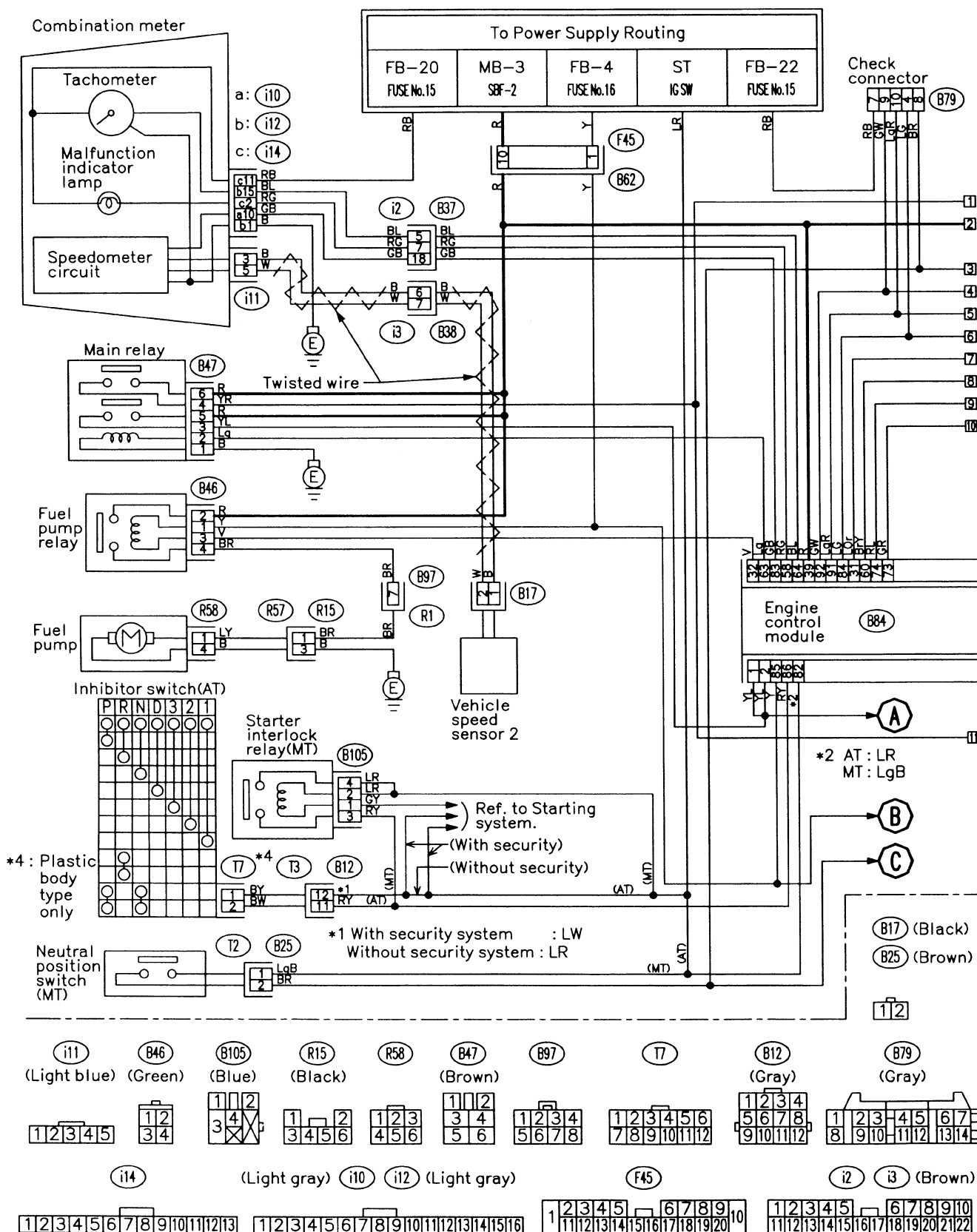

6. Wiring Diagram

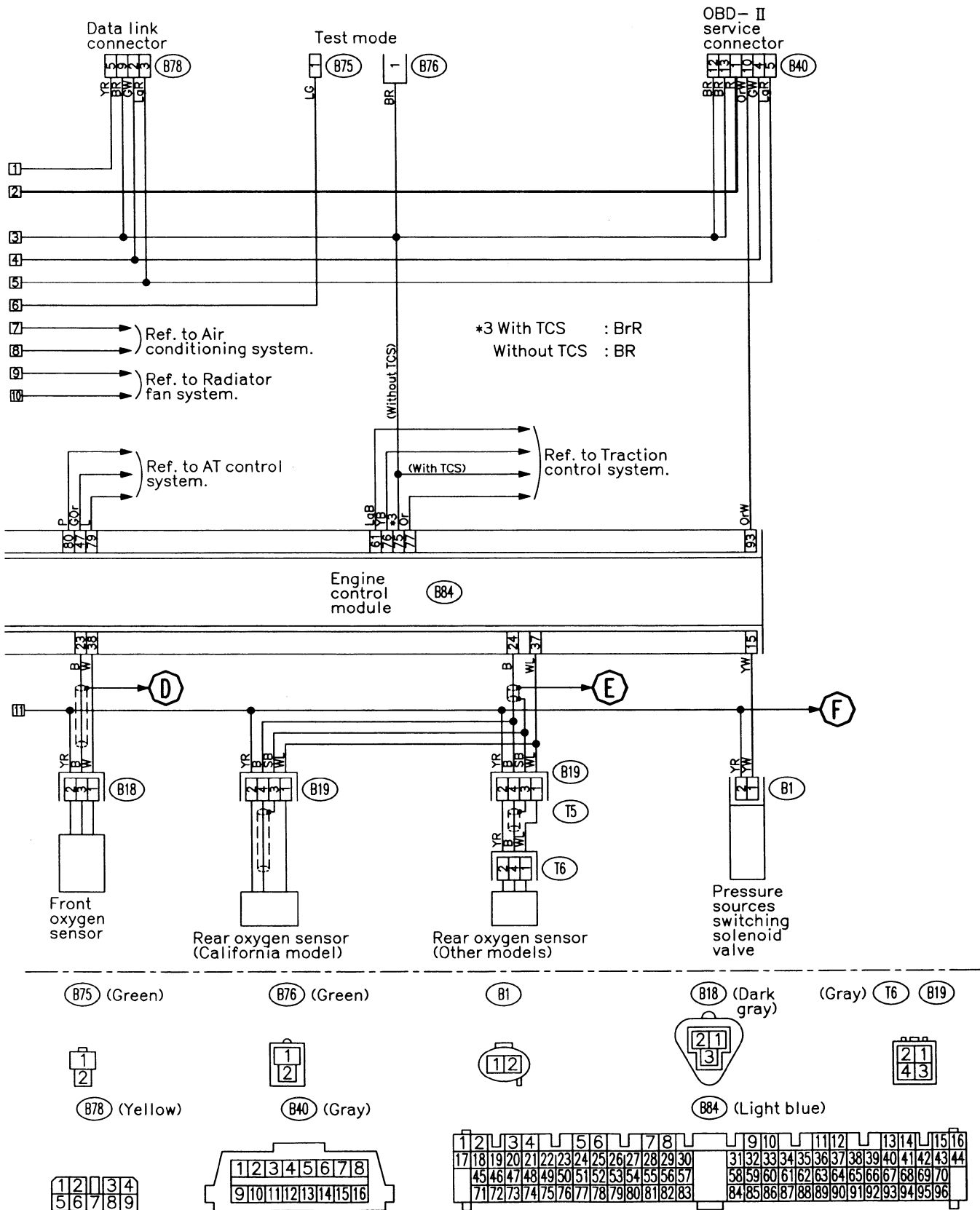



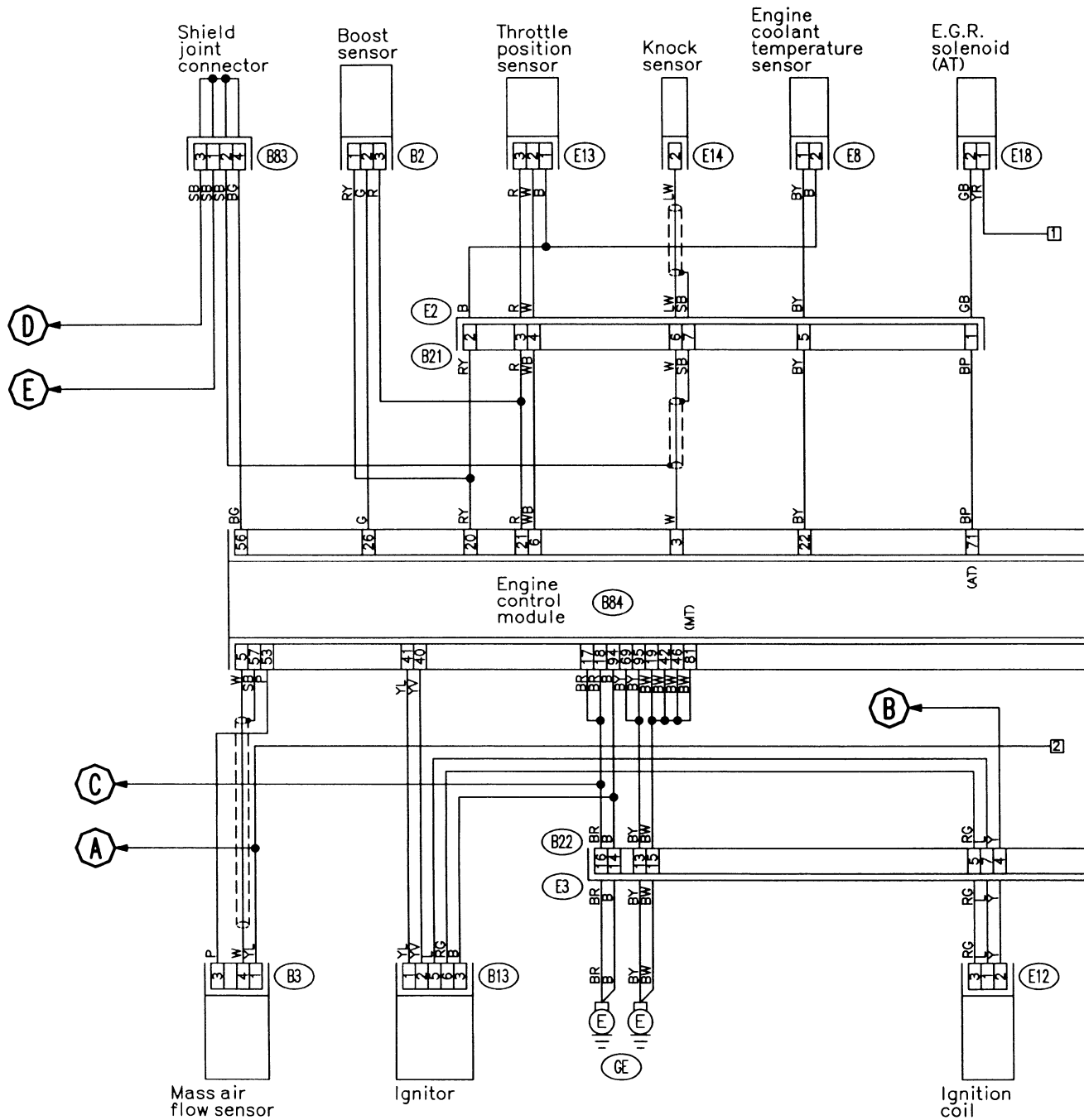

- (Brown) E14 (Gray)
- (Brown) E18 (Brown) E8 (Brown) (Black) B2 E13 (Brown)
- (E12) (Gray)
- (B83)
- (B3) (Gray)
- (B13) (Gray)
- (B21) (Light gray)
- (B22) (Light gray)
- (E14) (Gray)
- (E18) (Brown)
- (E8) (Brown)
- (B2) (Black)
- (E13) (Brown)
- (E12) (Gray)
- (B83)
- (B3) (Gray)
- (B13) (Gray)
- (B21) (Light gray)
- (B22) (Light gray)

6. Wiring Diagram

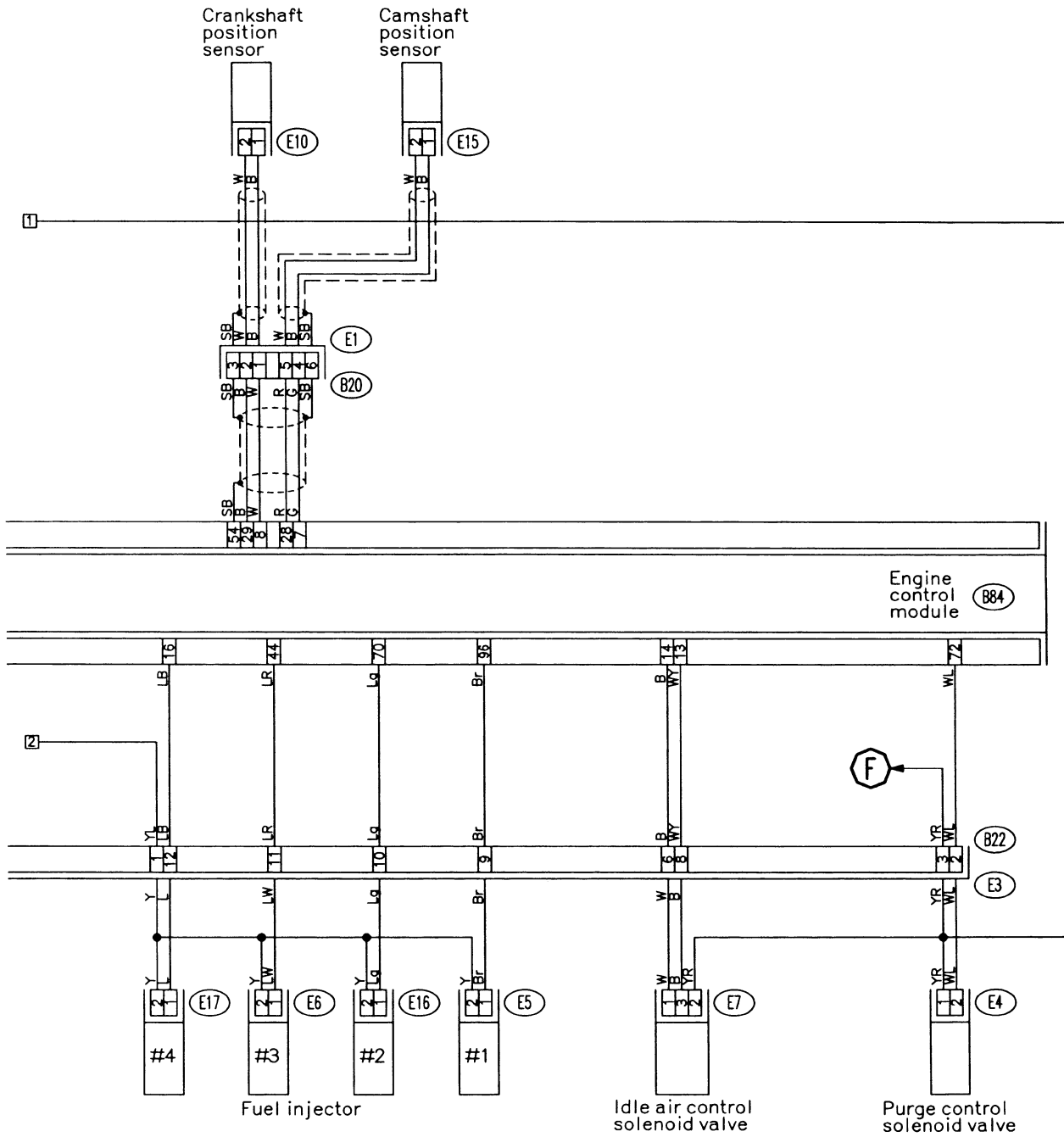

- (E15) (Dark gray)      (Light gray) (E5)      (E16) (Light gray)
- (E10) (Gray)          (Dark gray) (E6)      (E17) (Dark gray)
- (B84) (Light blue)
- (E4) (Blue)            (E7) (Gray)            (B20) (Light gray)

1	2	3	4	5	6	7	8	9	10	11	12	13	14	15	16
17	18	19	20	21	22	23	24	25	26	27	28	29	30	31	32
33	34	35	36	37	38	39	40	41	42	43	44	45	46	47	48
49	50	51	52	53	54	55	56	57	58	59	60	61	62	63	64
65	66	67	68	69	70	71	72	73	74	75	76	77	78	79	80
81	82	83	84	85	86	87	88	89	90	91	92	93	94	95	96



6. Wiring Diagram

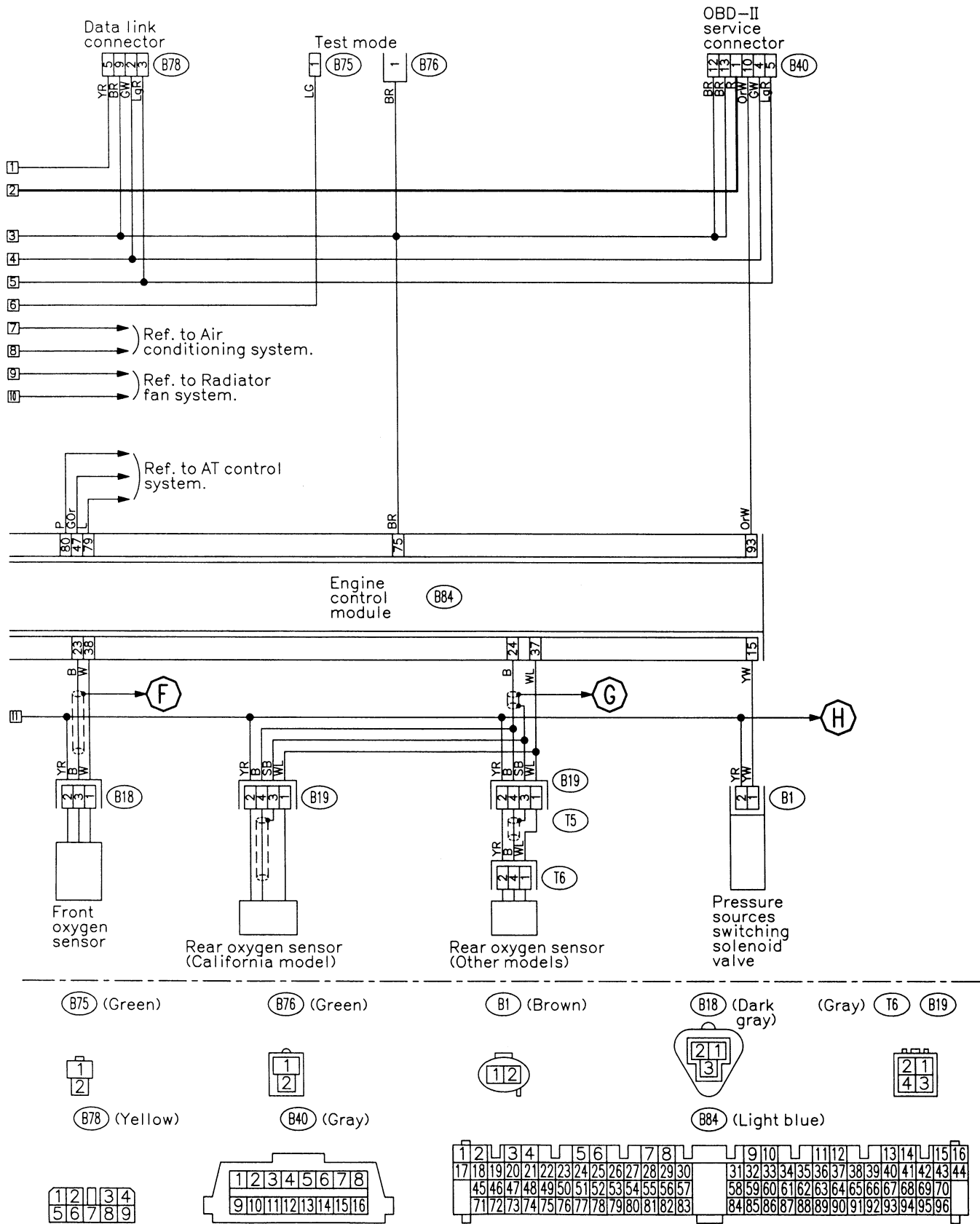





14. FRONT FOG LIGHT SYSTEM

● Without DRL model

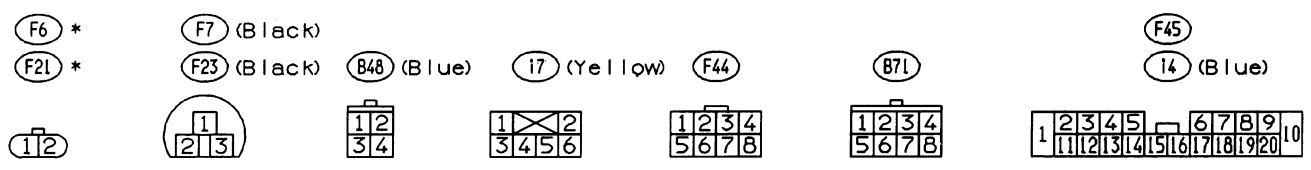
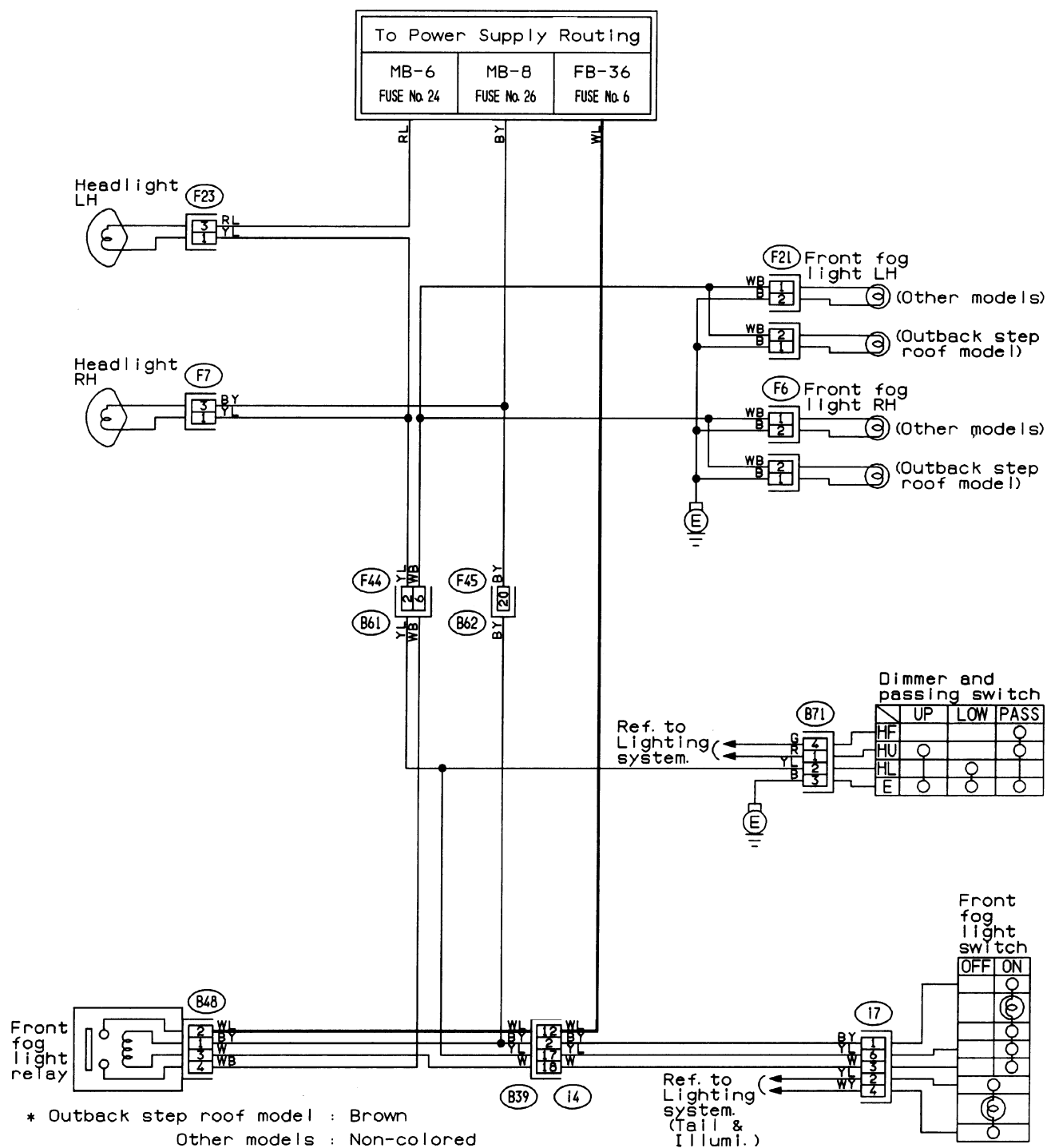

14. FRONT FOG LIGHT SYSTEM

● With DRL model

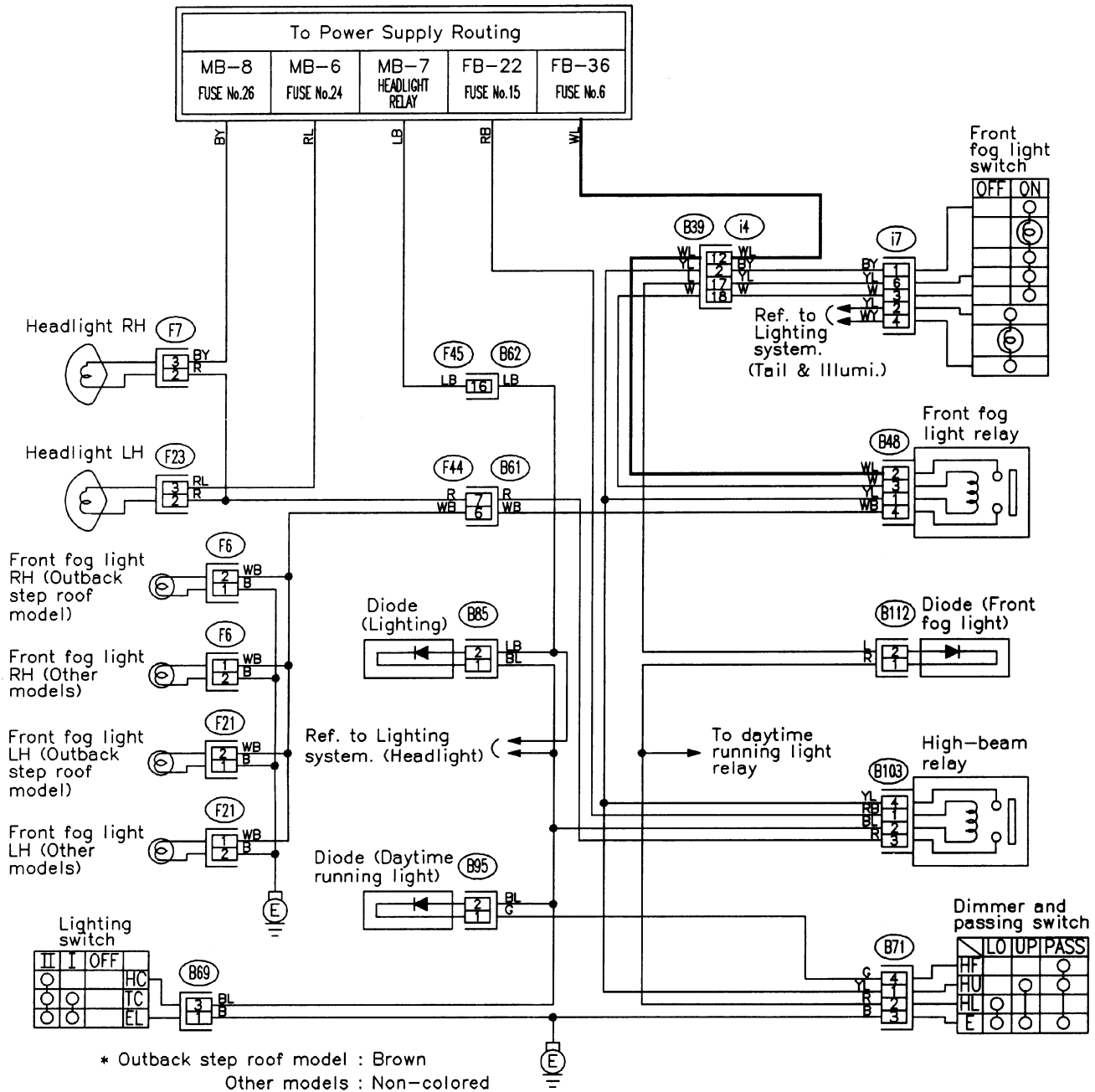

- (B85) (Black)    (F6) \*
- (B95) (Black)    (F21) \*
- (B112) (Black)
- (B85) (Black)    (F7) (Black)    (B48) (Blue)    (B103) (Blue)    (i7) (Yellow)
- (B95) (Black)    (F23) (Black)
- (B112) (Black)
- (F44)    (B71)
- (B69) (Black)
- (i4) (Blue)
- (F45)



15. FRONT WIPER AND WASHER SYSTEM

● LHD model

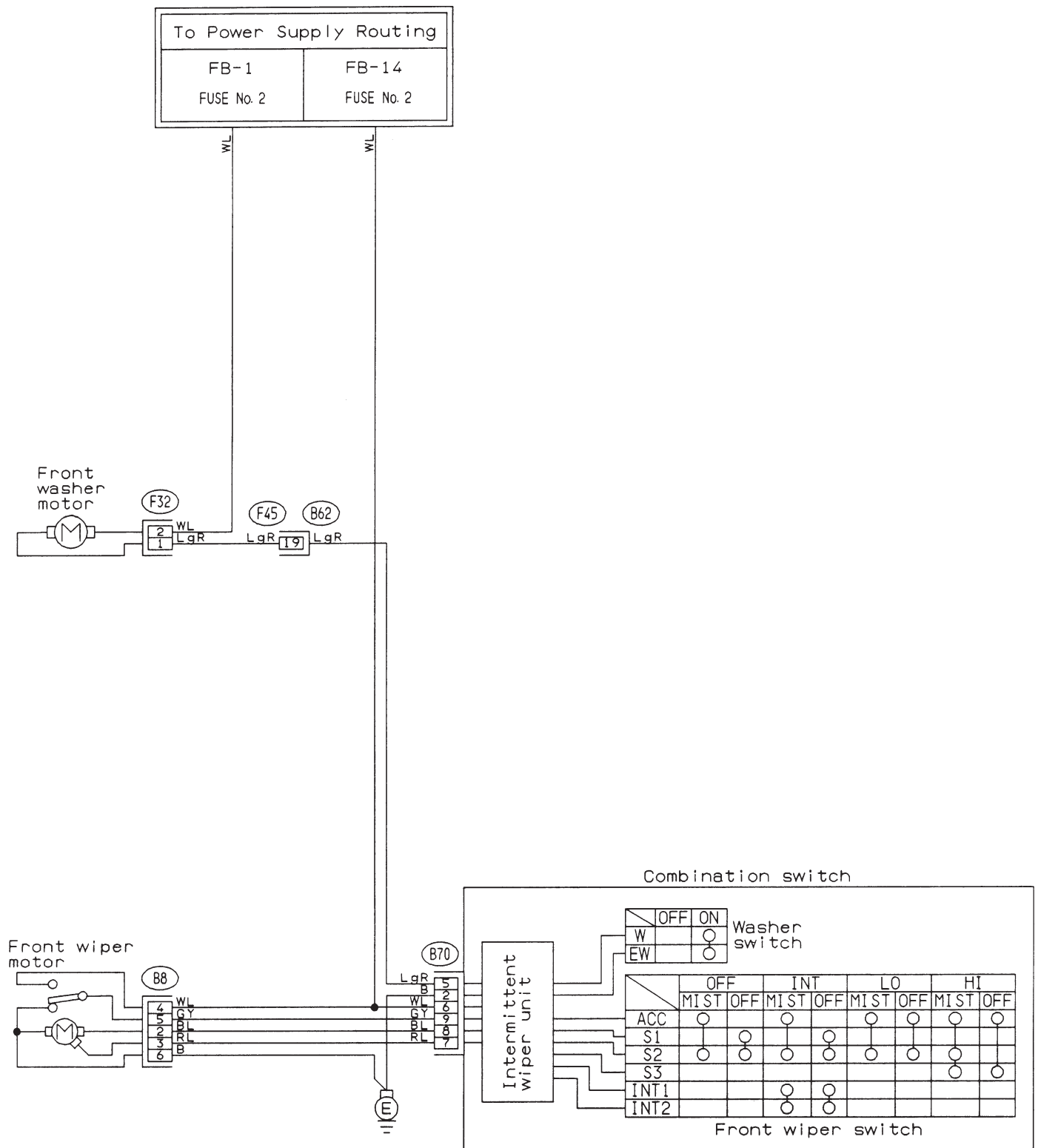

F32 (Green)



B8



B70

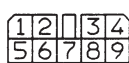

F45



15. FRONT WIPER AND WASHER SYSTEM

● RHD model

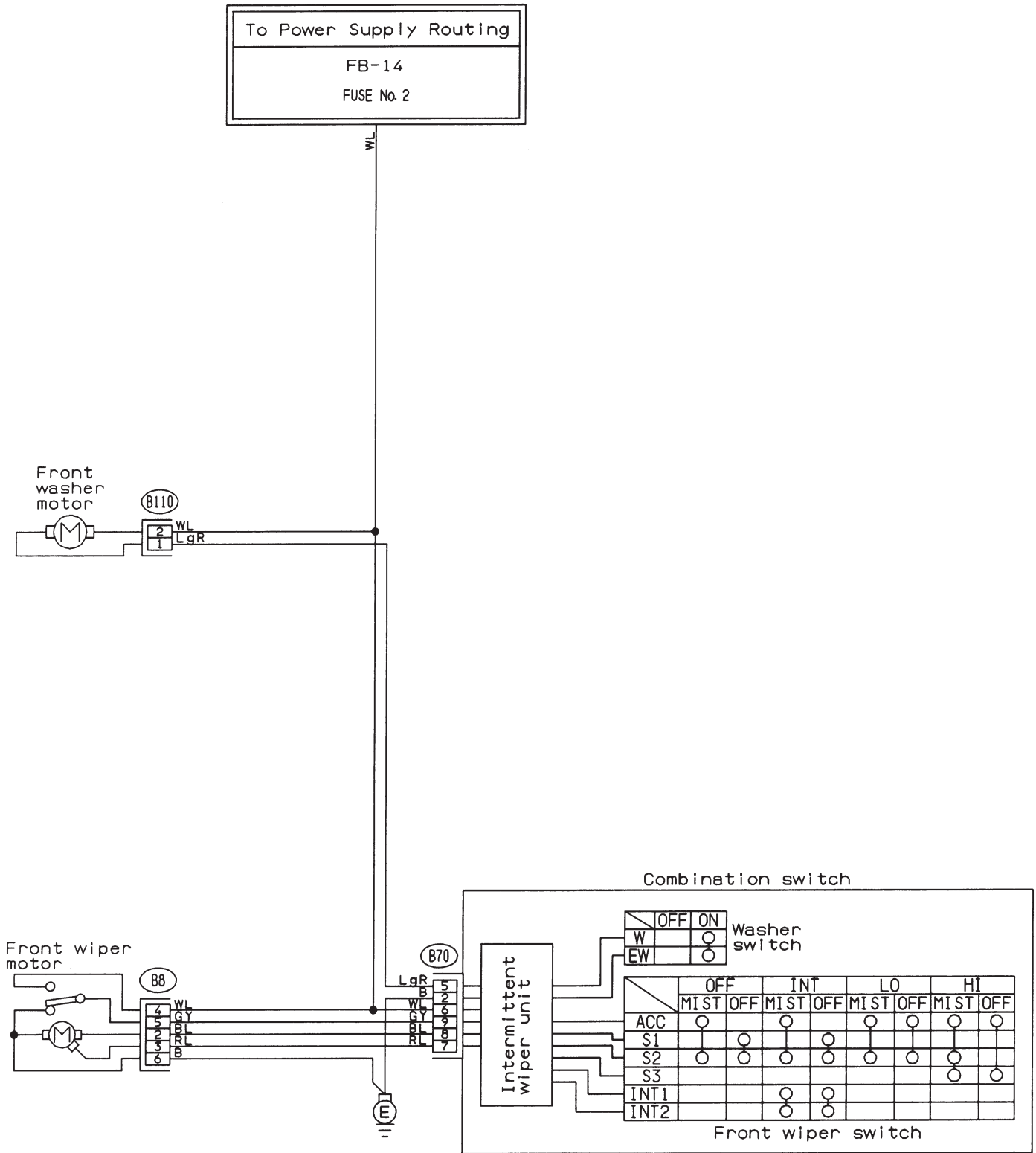

(B110) (Green)



(B8)



(B70)

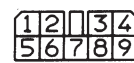

16. FUEL GAUGE SYSTEM

● LHD model

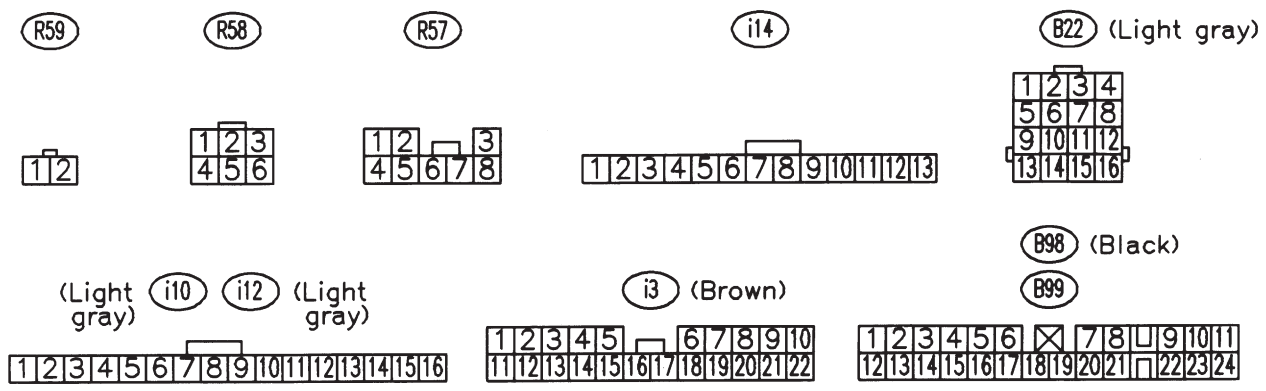
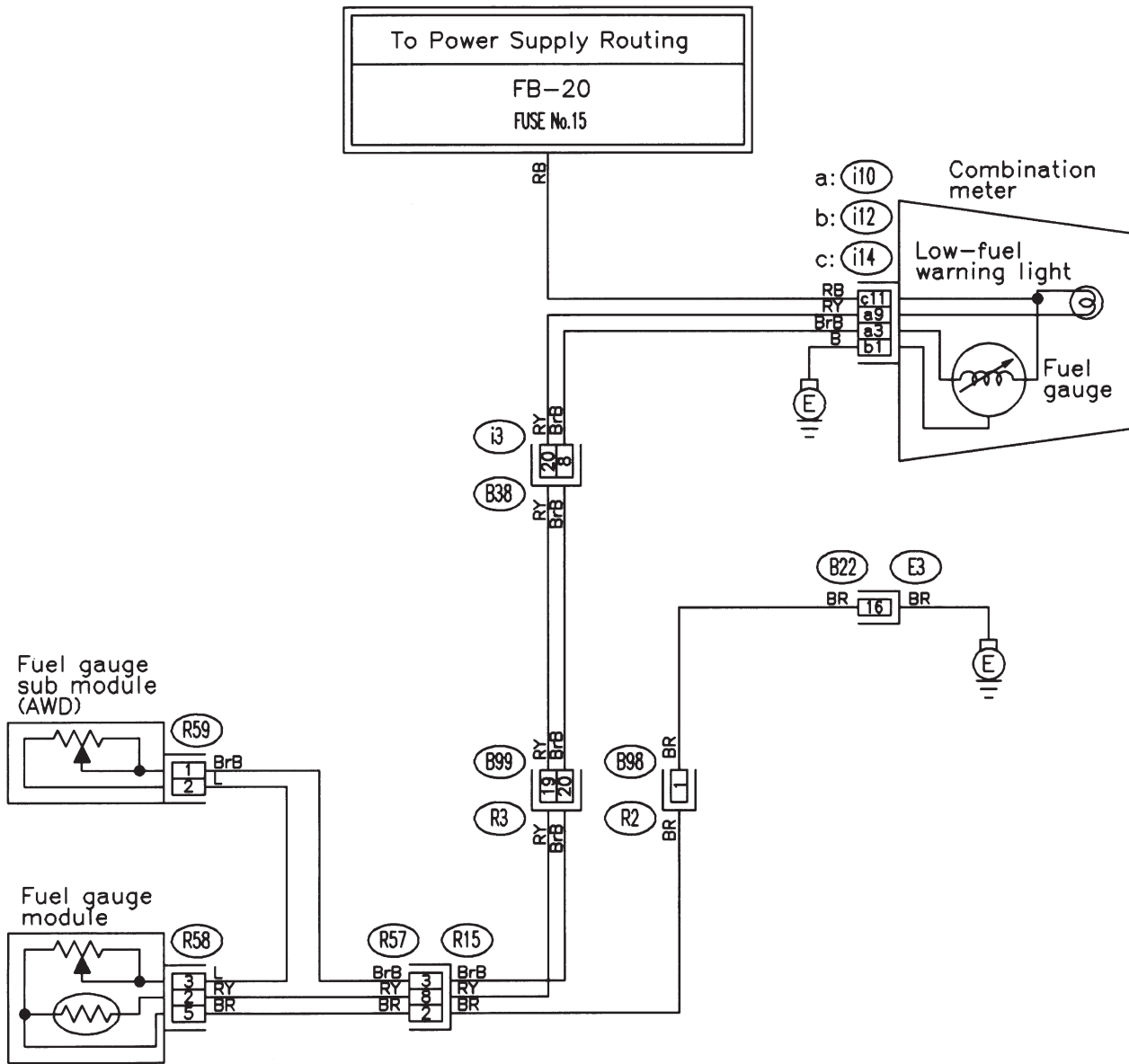

BU61-02

16. FUEL GAUGE SYSTEM

● RHD model

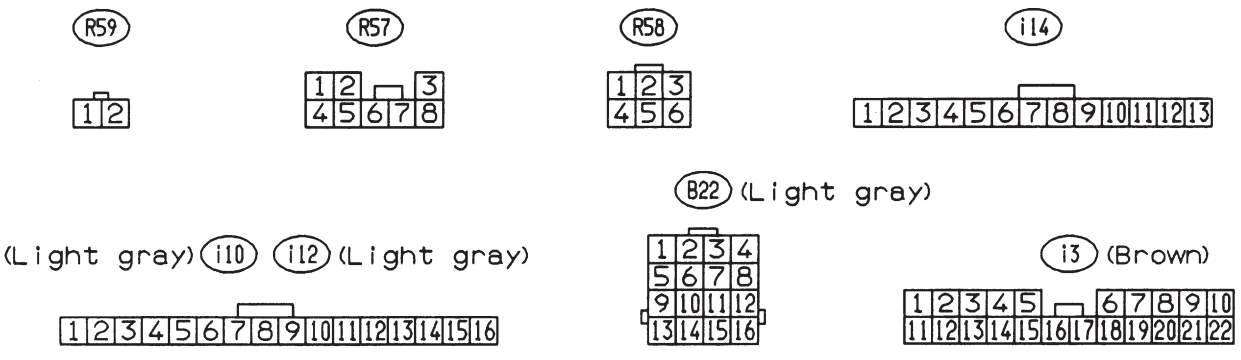
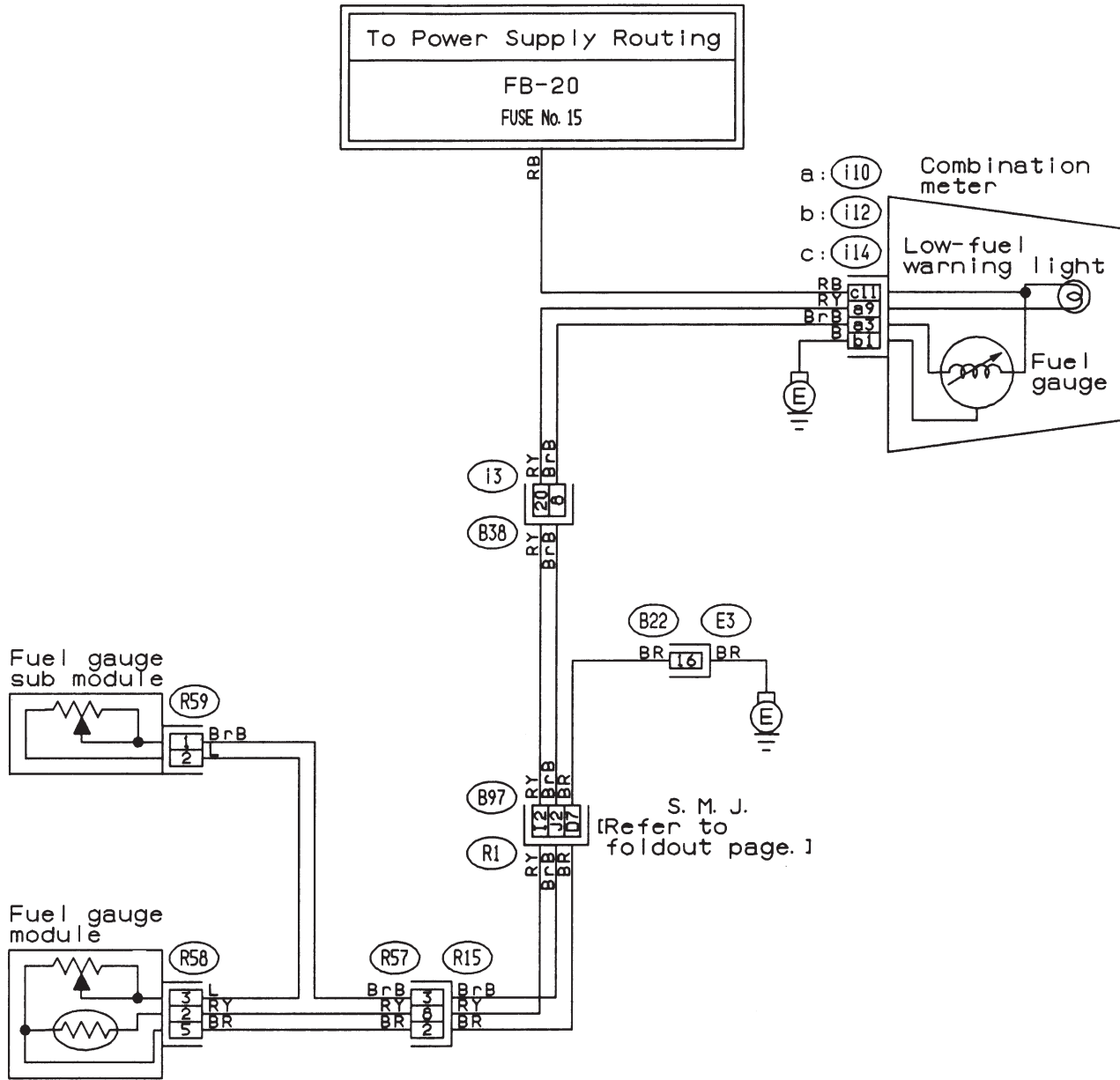

BUR61-02

17. HORN AND FRONT ACCESSORY POWER SUPPLY SYSTEM

● LHD model

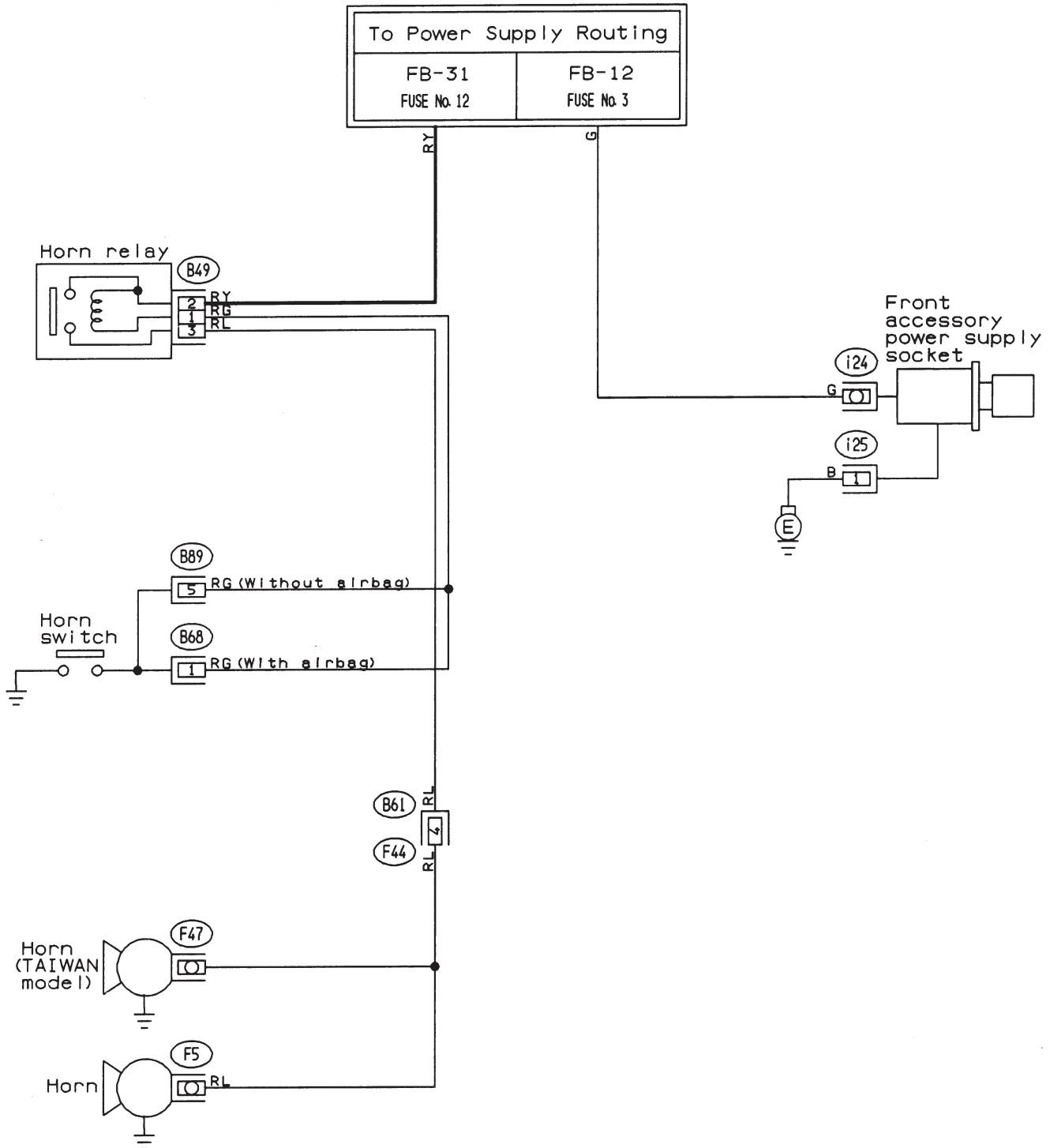

(i25)

(B49) (Black)



(B68) (Black)



(F44)



(B89) (Black)

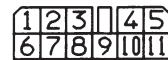

BU74-02

17. HORN AND FRONT ACCESSORY POWER SUPPLY SYSTEM

● RHD model

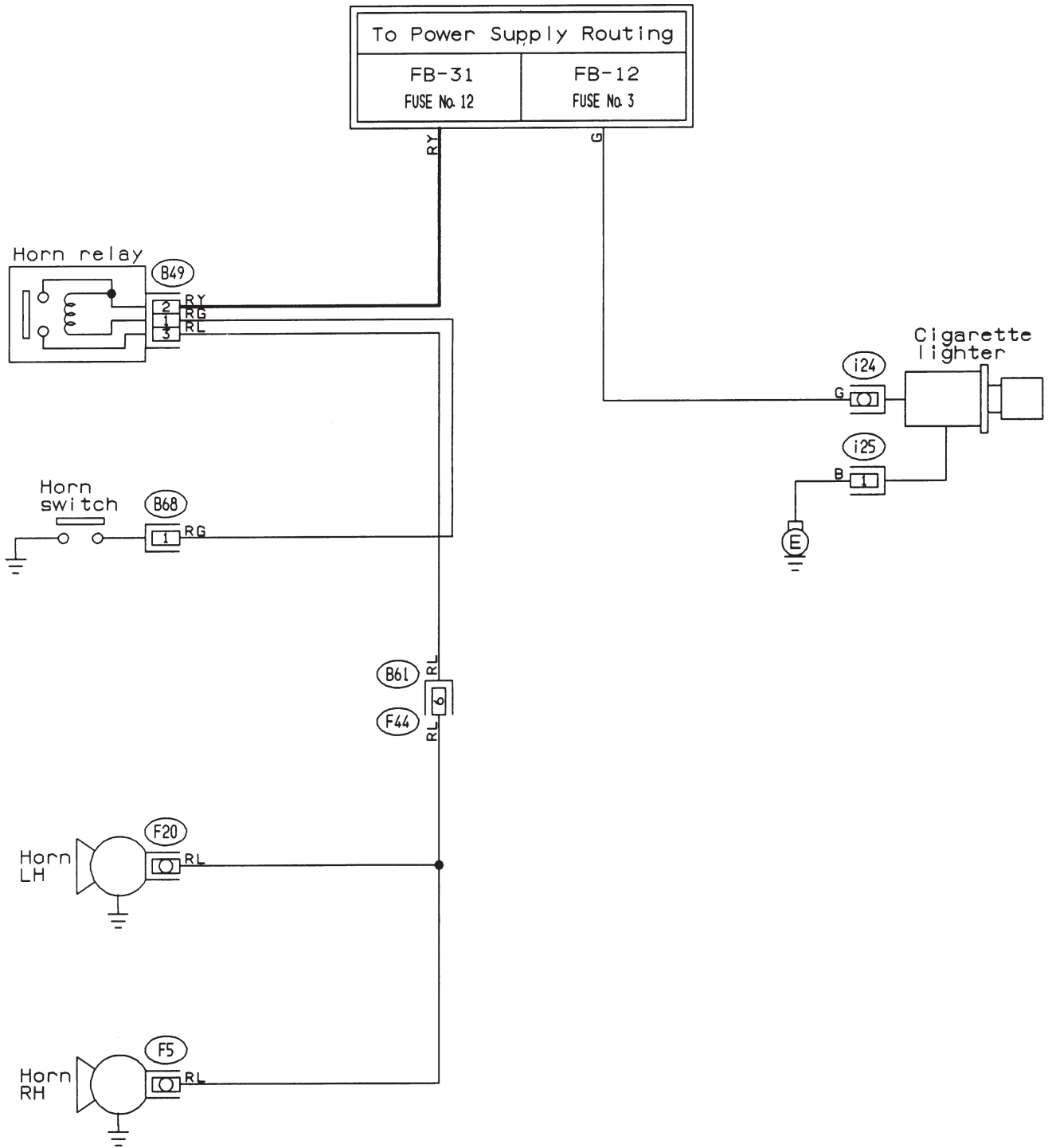

(i25) (B49) (Black)



(B68) (Black)



(F44)

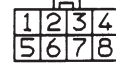

BUR74-01

18. LIGHTING (HEADLIGHT) SYSTEM

● LHD without DRL model

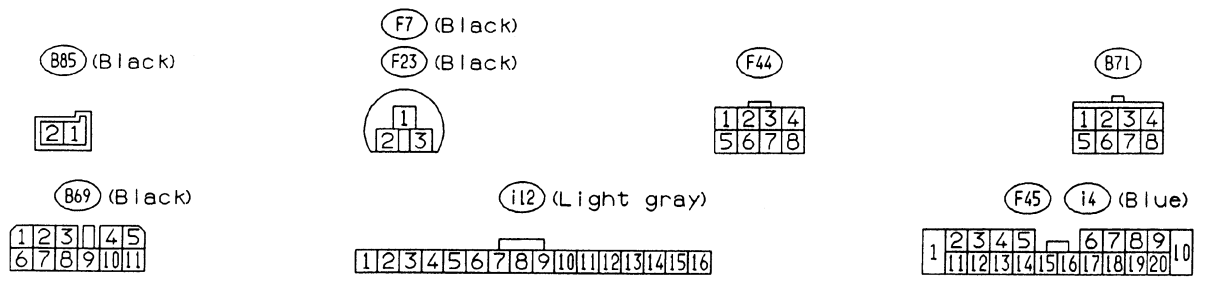
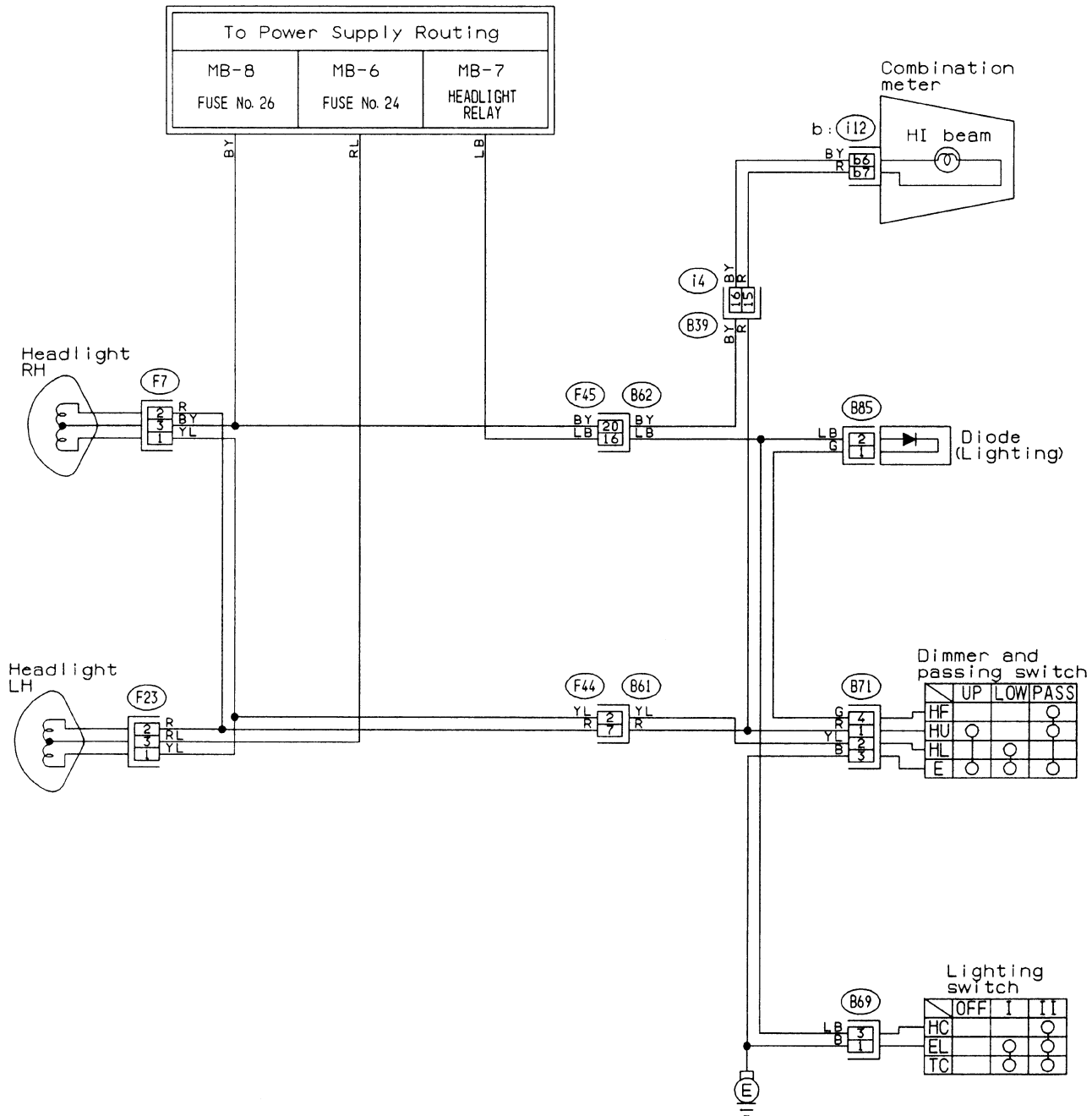

18. LIGHTING (HEADLIGHT) SYSTEM

- LHD with DRL model

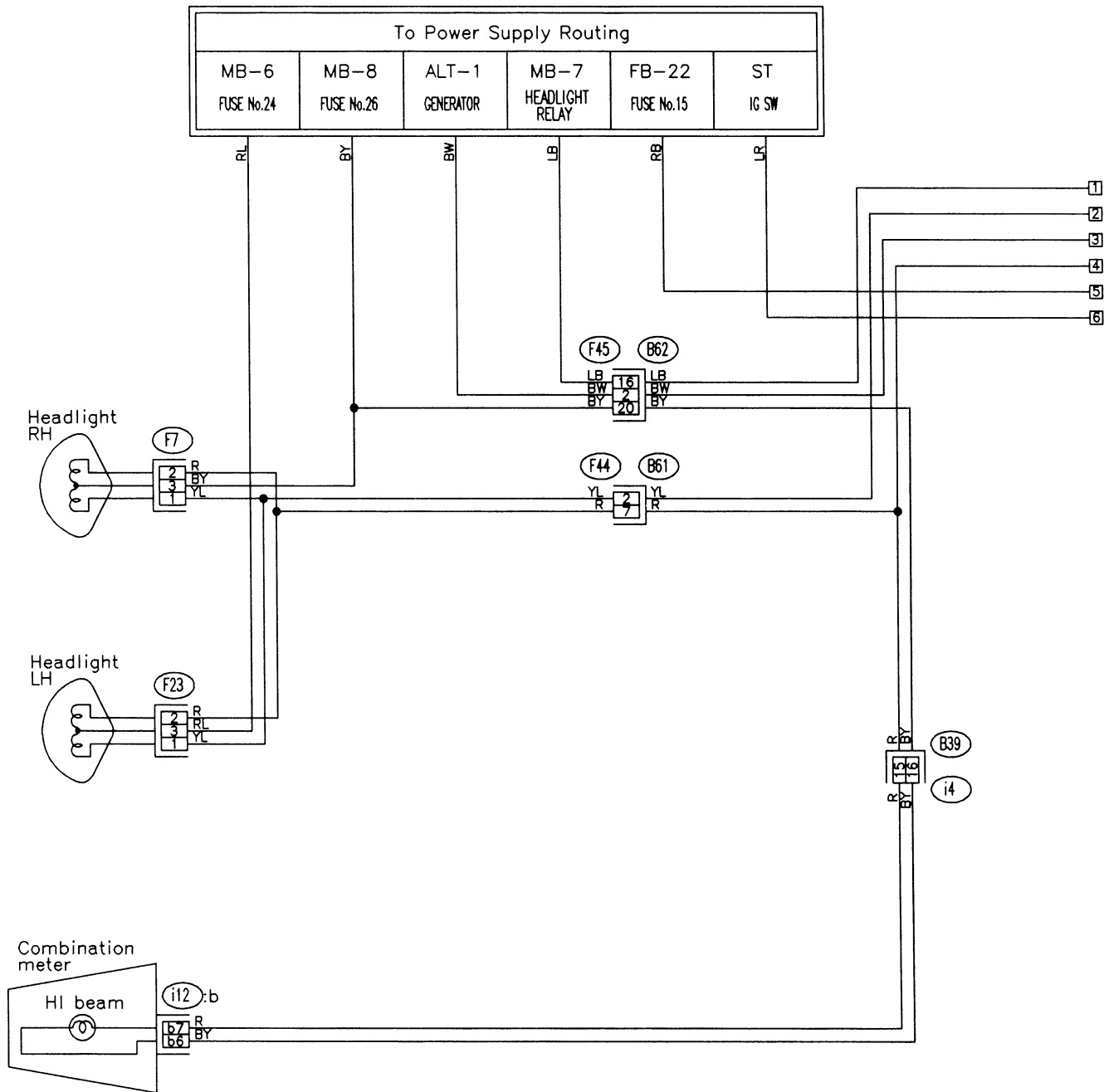

(F7) (Black)

(F23) (Black)



(i12) (Light gray)

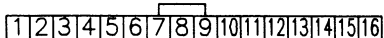

(F44)

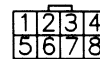

(F45) (i4) (Blue)

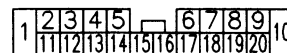



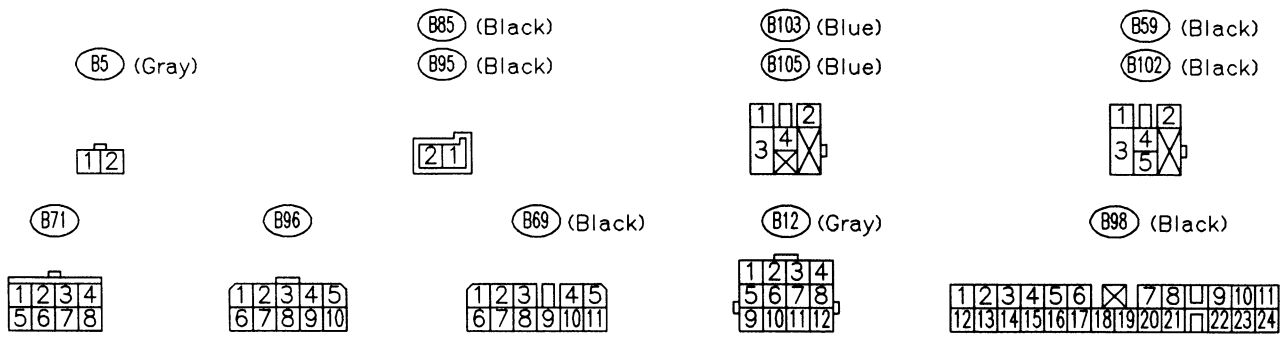
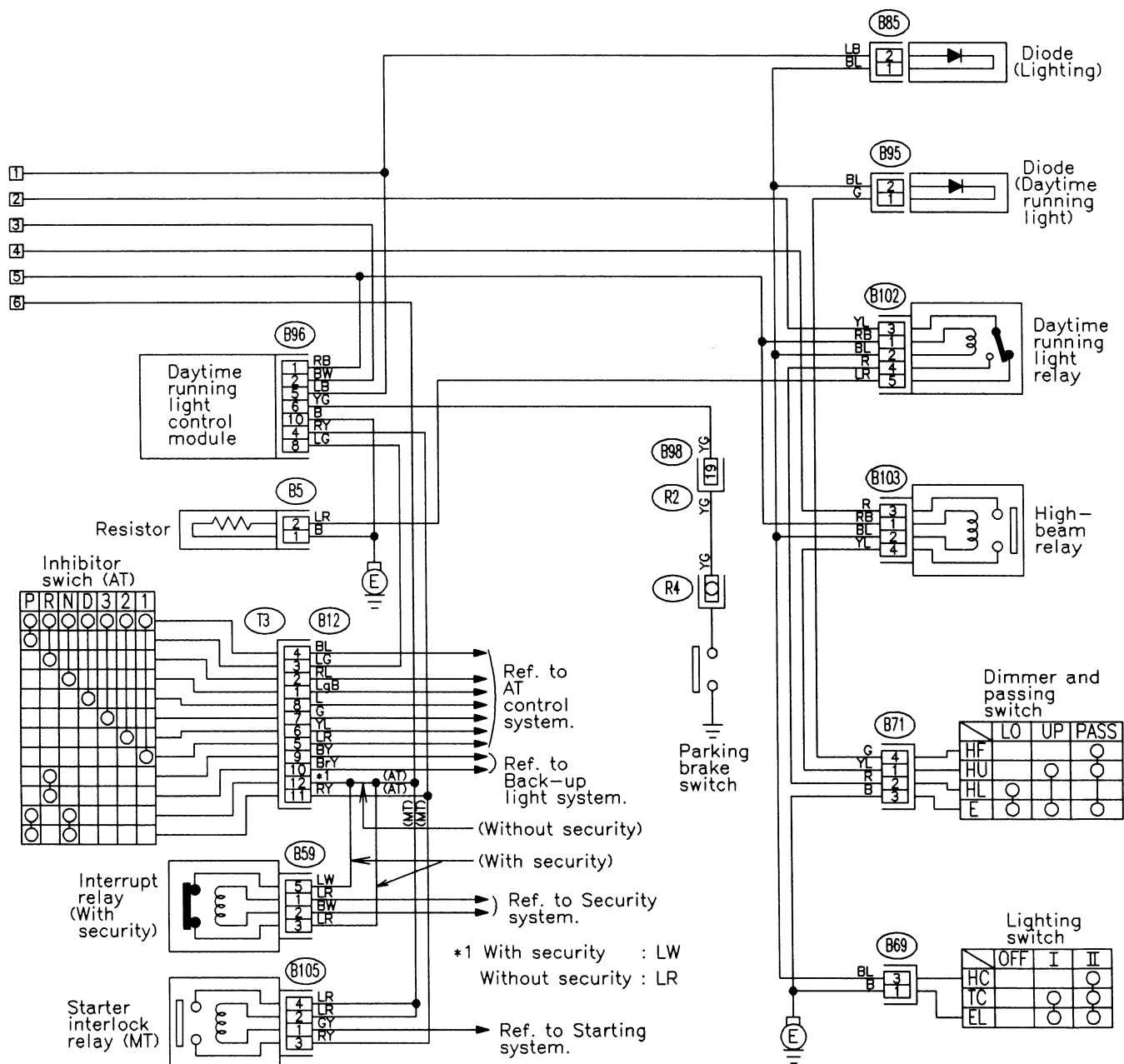

18. LIGHTING (HEADLIGHT) SYSTEM

● RHD model

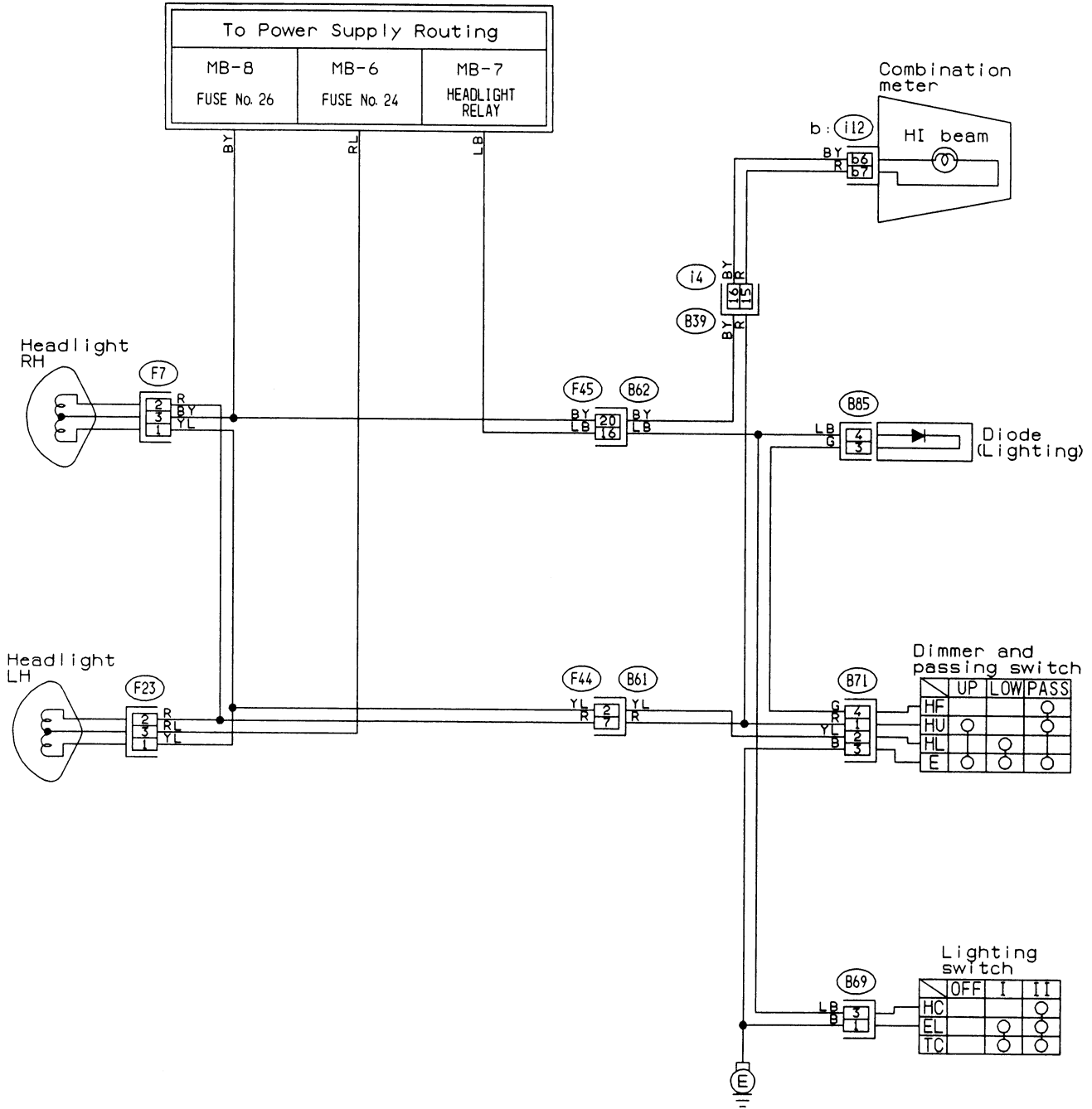

(F7) (Black)  
(F23) (Black)



(B85) (Brown)

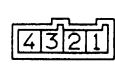

(F44)

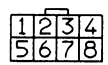

(B71)

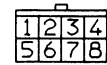

(B69) (Black)

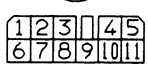

(i12) (Light gray)

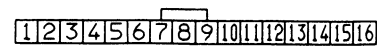

(F45) (i4) (Blue)

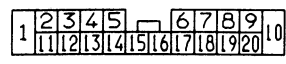

19. LIGHTING  
(TAIL LIGHT-ILLUMINATION LIGHT-ETC.) SYSTEM

● LHD model

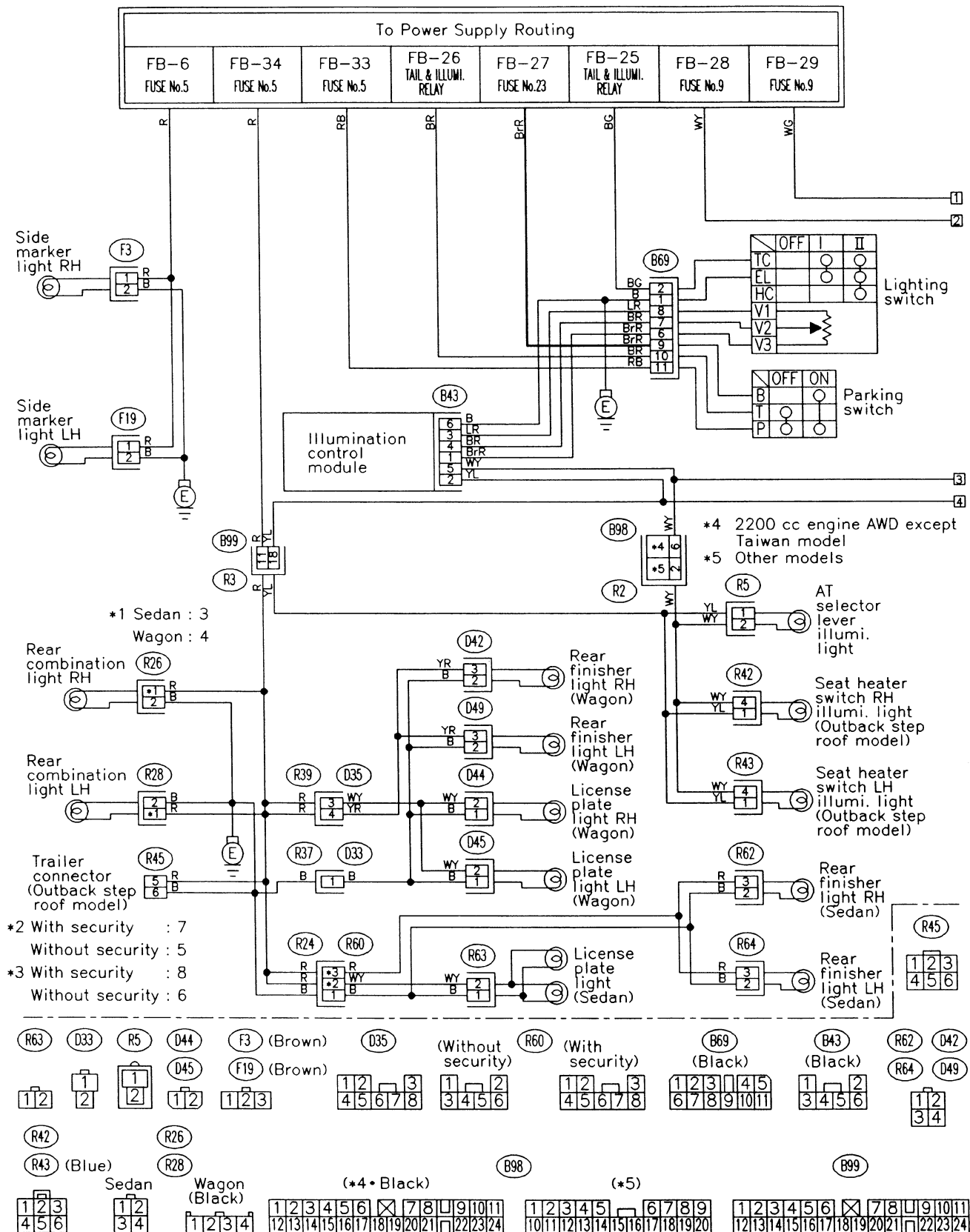

6. Wiring Diagram

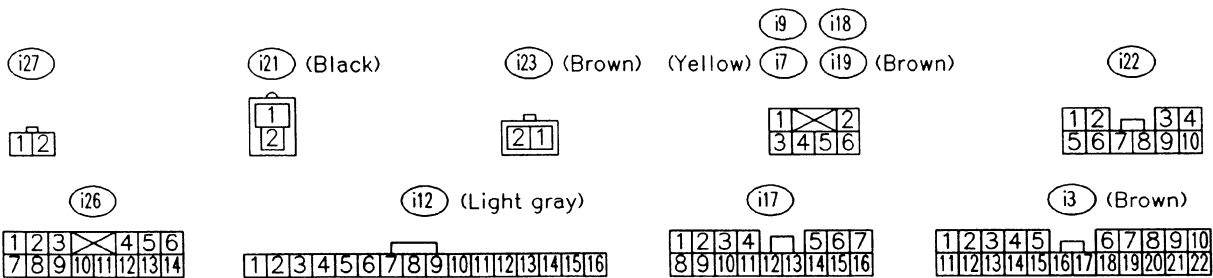
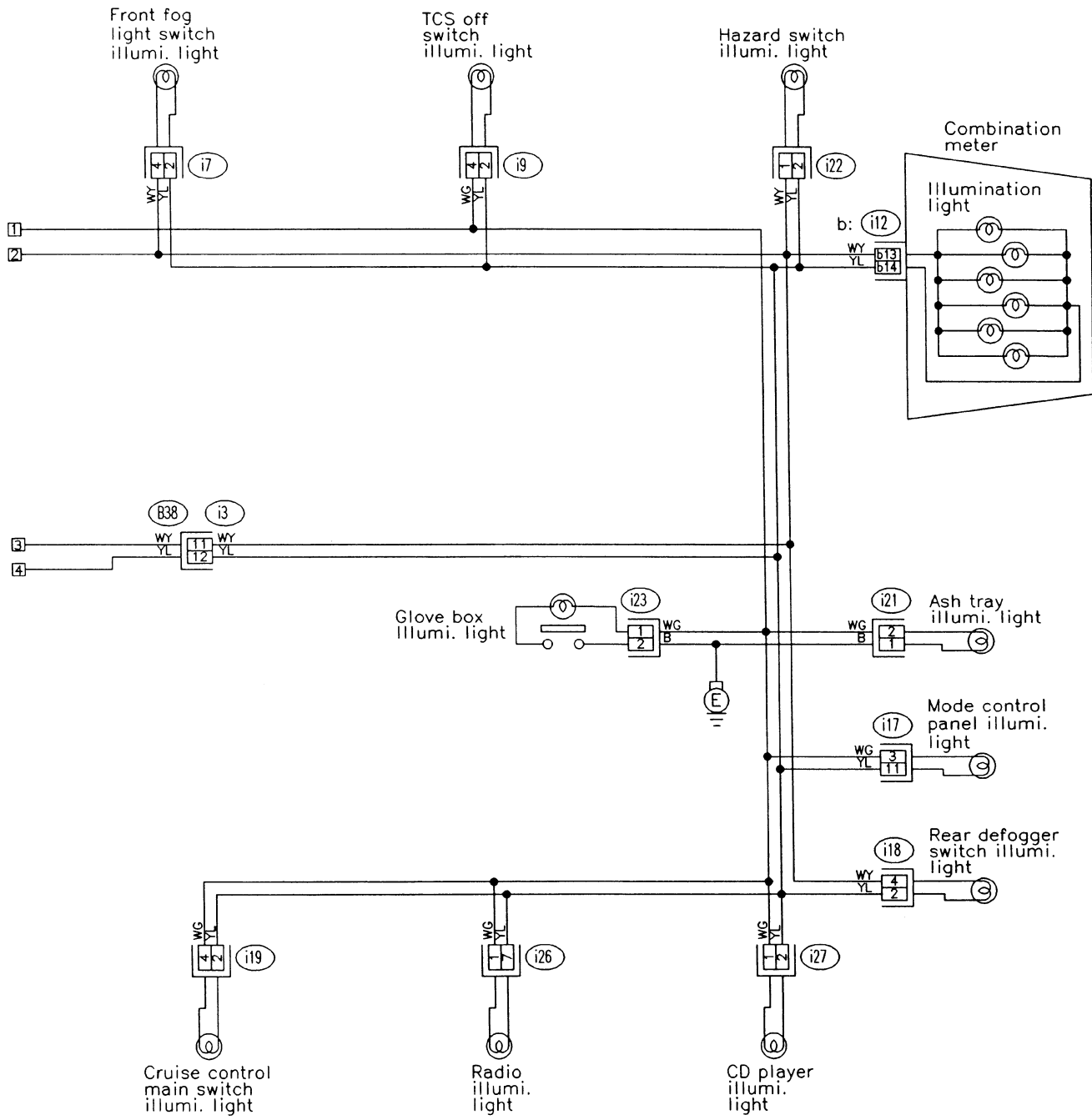

19. LIGHTING  
(TAIL LIGHT-ILLUMINATION LIGHT-ETC.) SYSTEM  
● RHD model

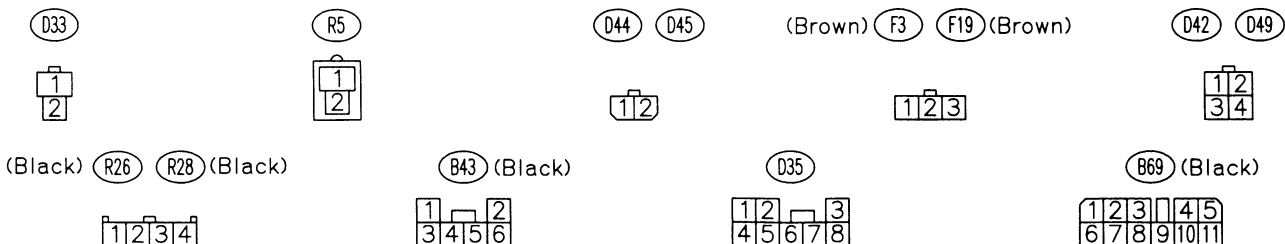
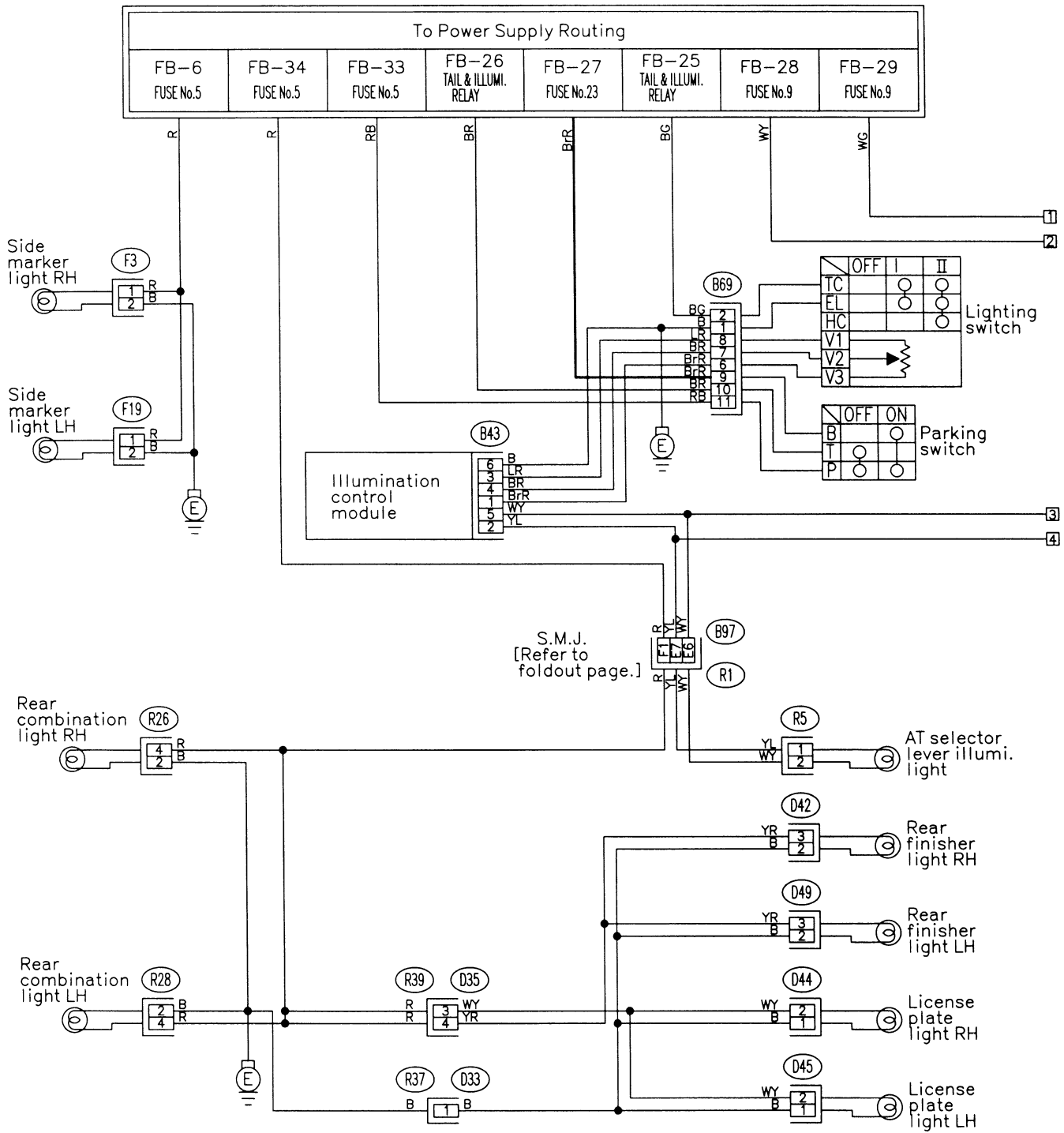

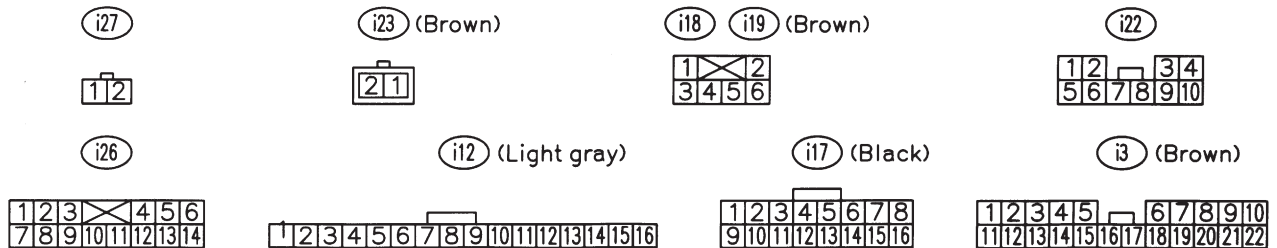
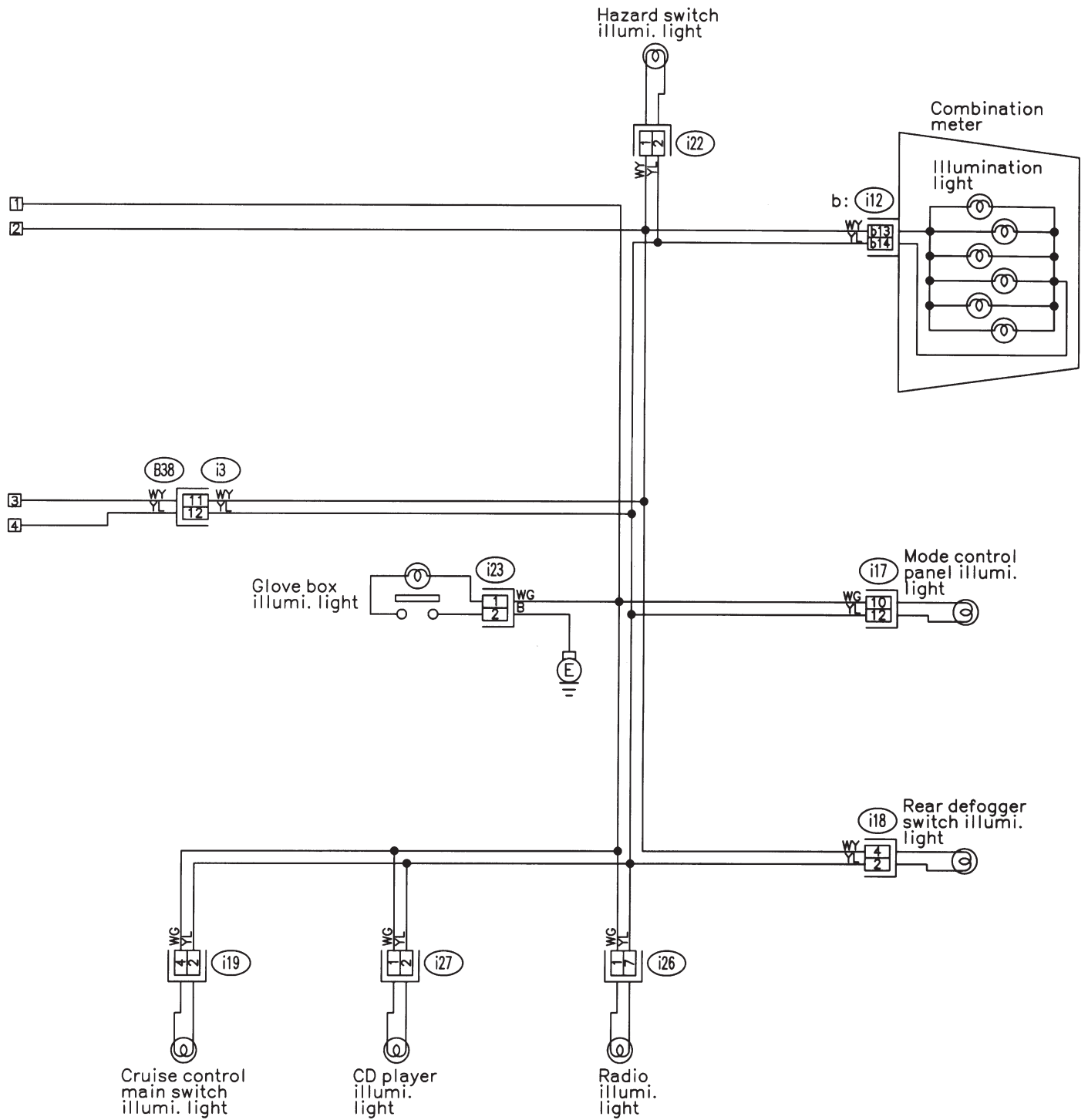

BUR21-02B

20. OIL PRESSURE AND TEMPERATURE GAUGE SYSTEM

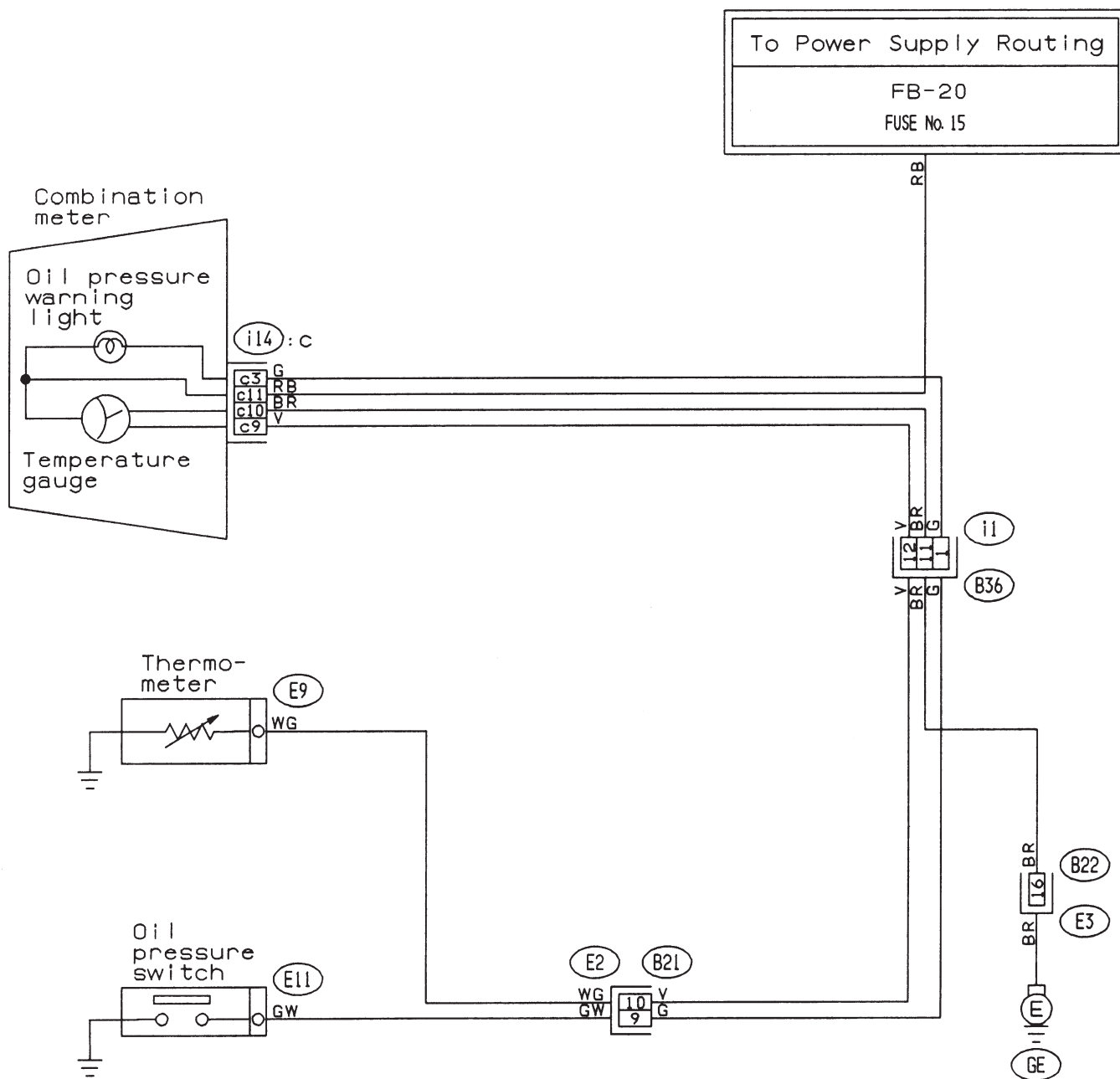

(B21) (Light gray)

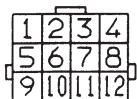

(i14)

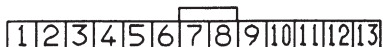

(B22) (Light gray)

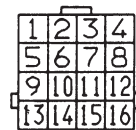

(i1) (Black)

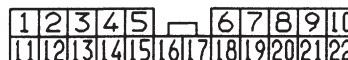

BU66-01

21. PARKING BRAKE AND BRAKE FLUID LEVEL WARNING SYSTEM

● LHD model

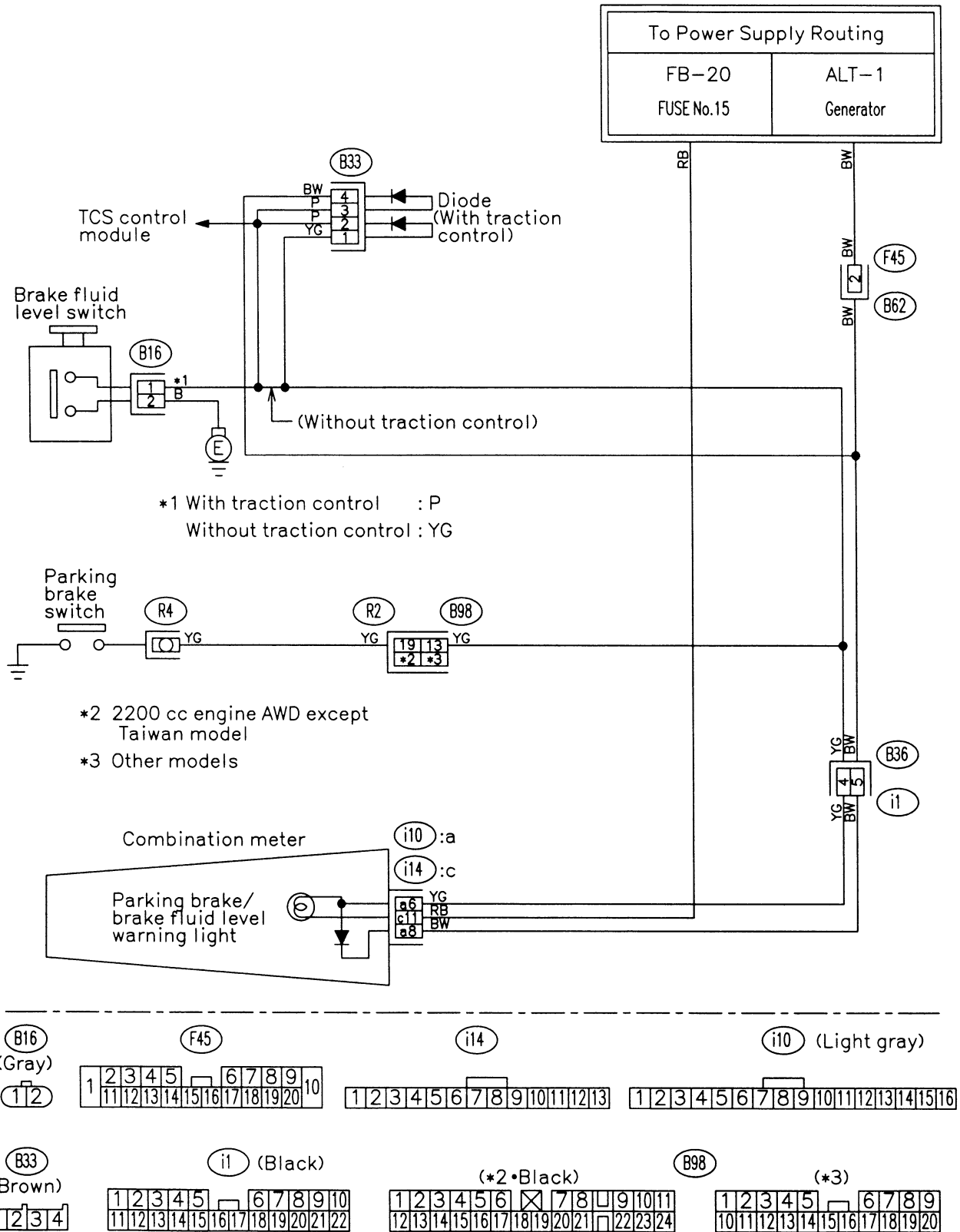



21. PARKING BRAKE AND BRAKE FLUID LEVEL WARNING SYSTEM

- RHD model

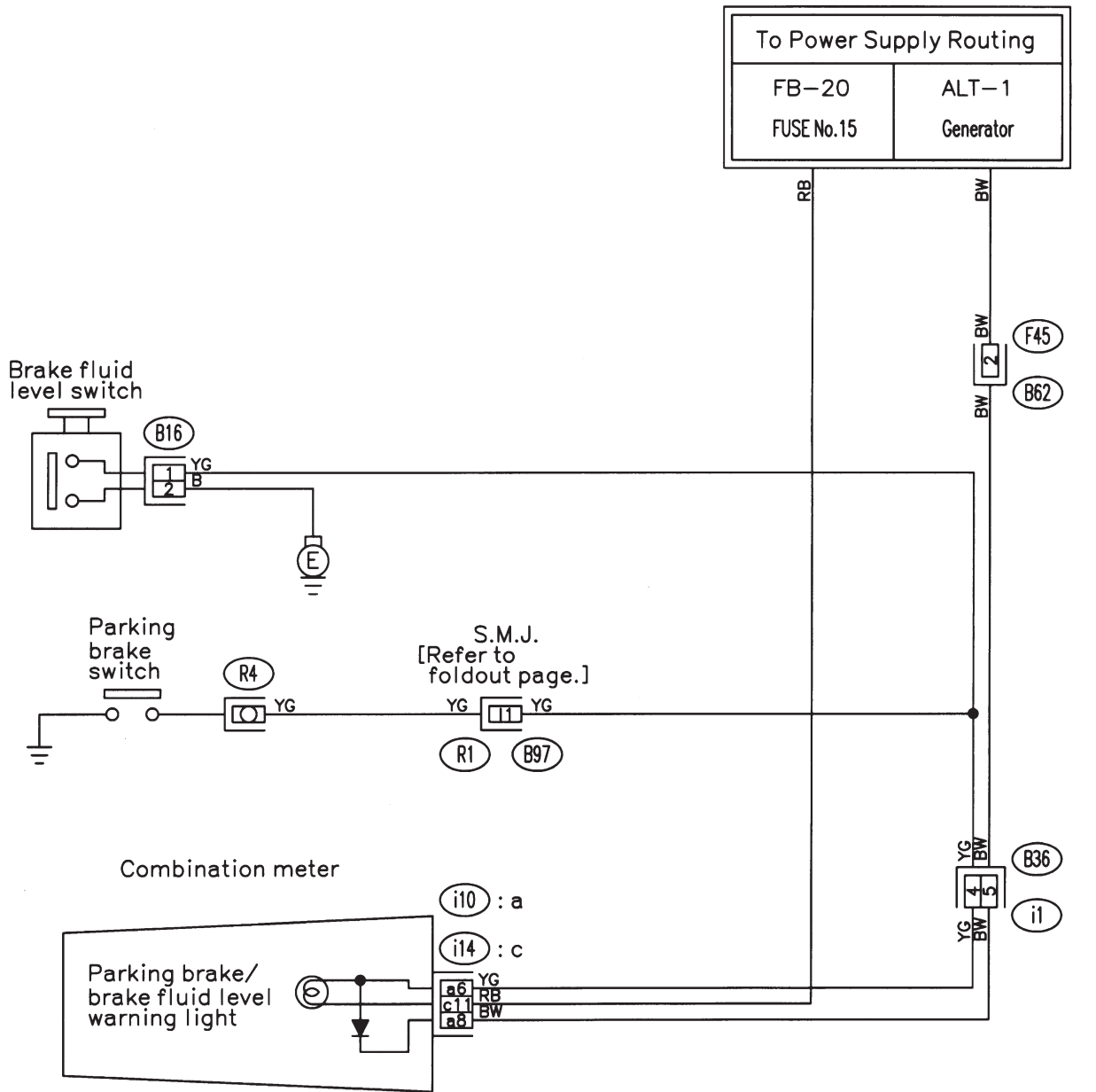

(B16) (Gray)



(i14)



(i10) (Light gray)

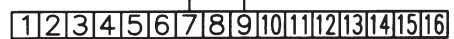

(F45)



(i1) (Black)



BUR60-02

22. POWER WINDOW SYSTEM

● LHD model

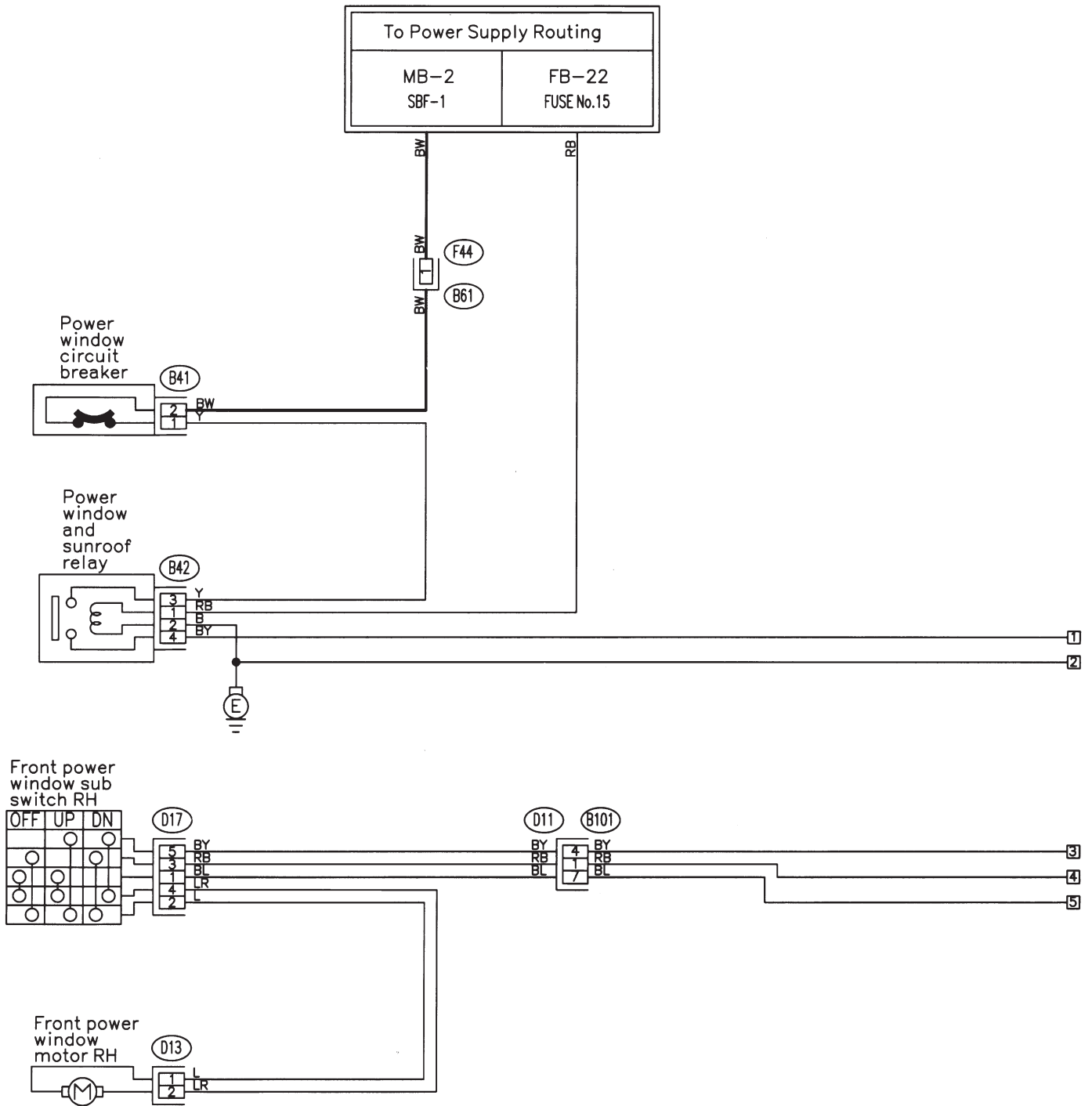

(Green) (B41) (D3) (D13) (Green)  
 (Green) (D30) (D24) (Green)

(B42)

(F44)

(B30) (B101)

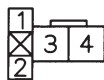

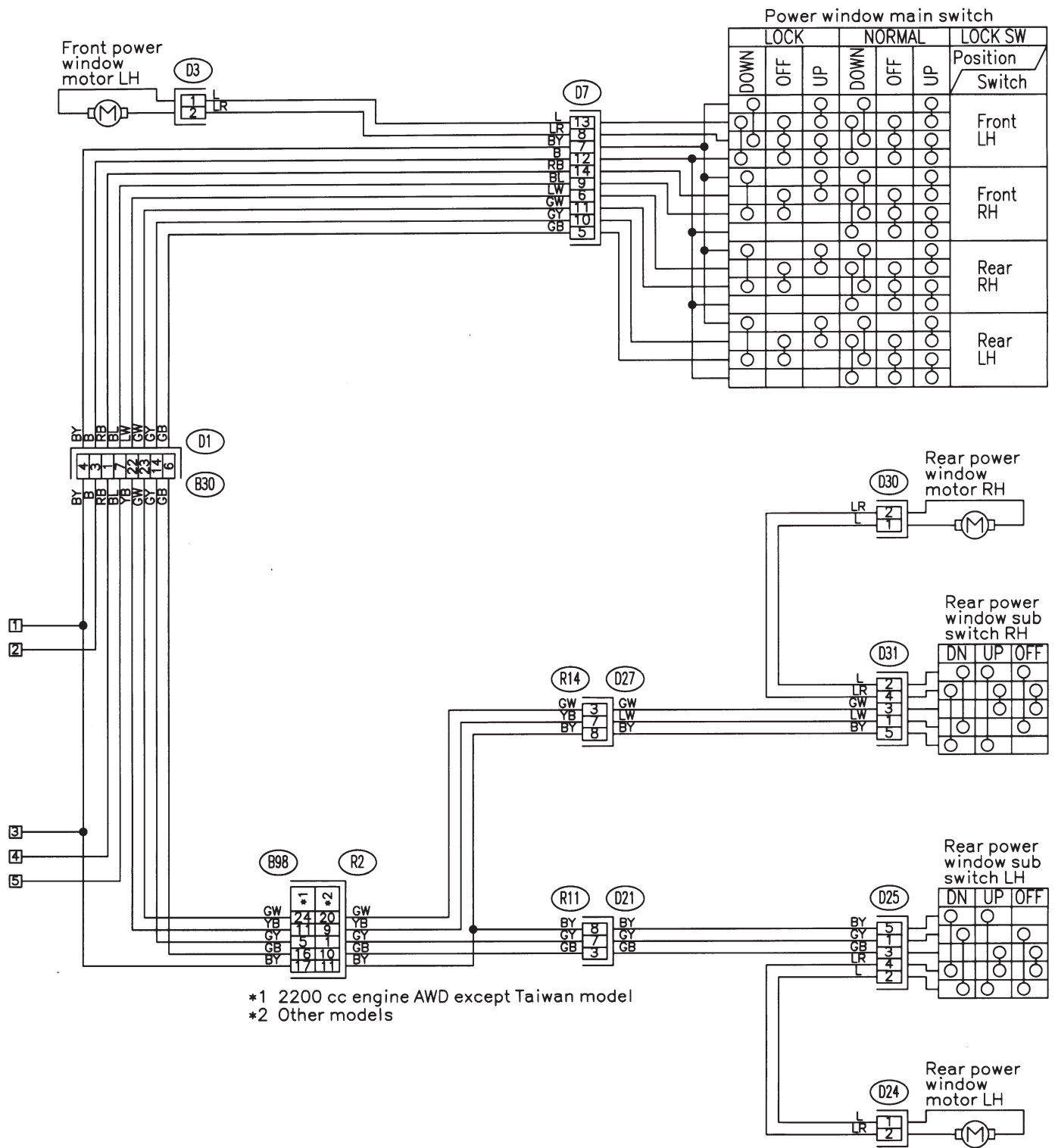

\*1 2200 cc engine AWD except Taiwan model  
 \*2 Other models

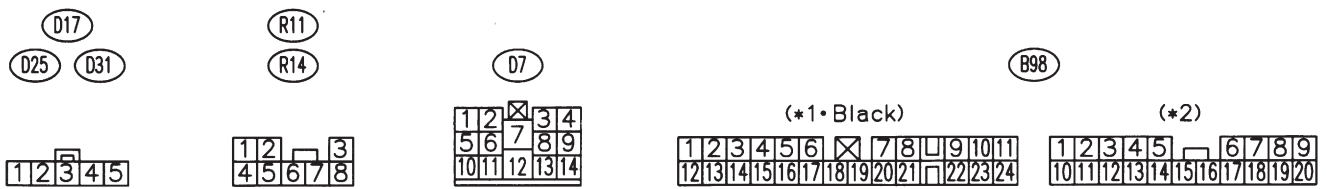

BU70-03B

22. POWER WINDOW SYSTEM

● RHD model

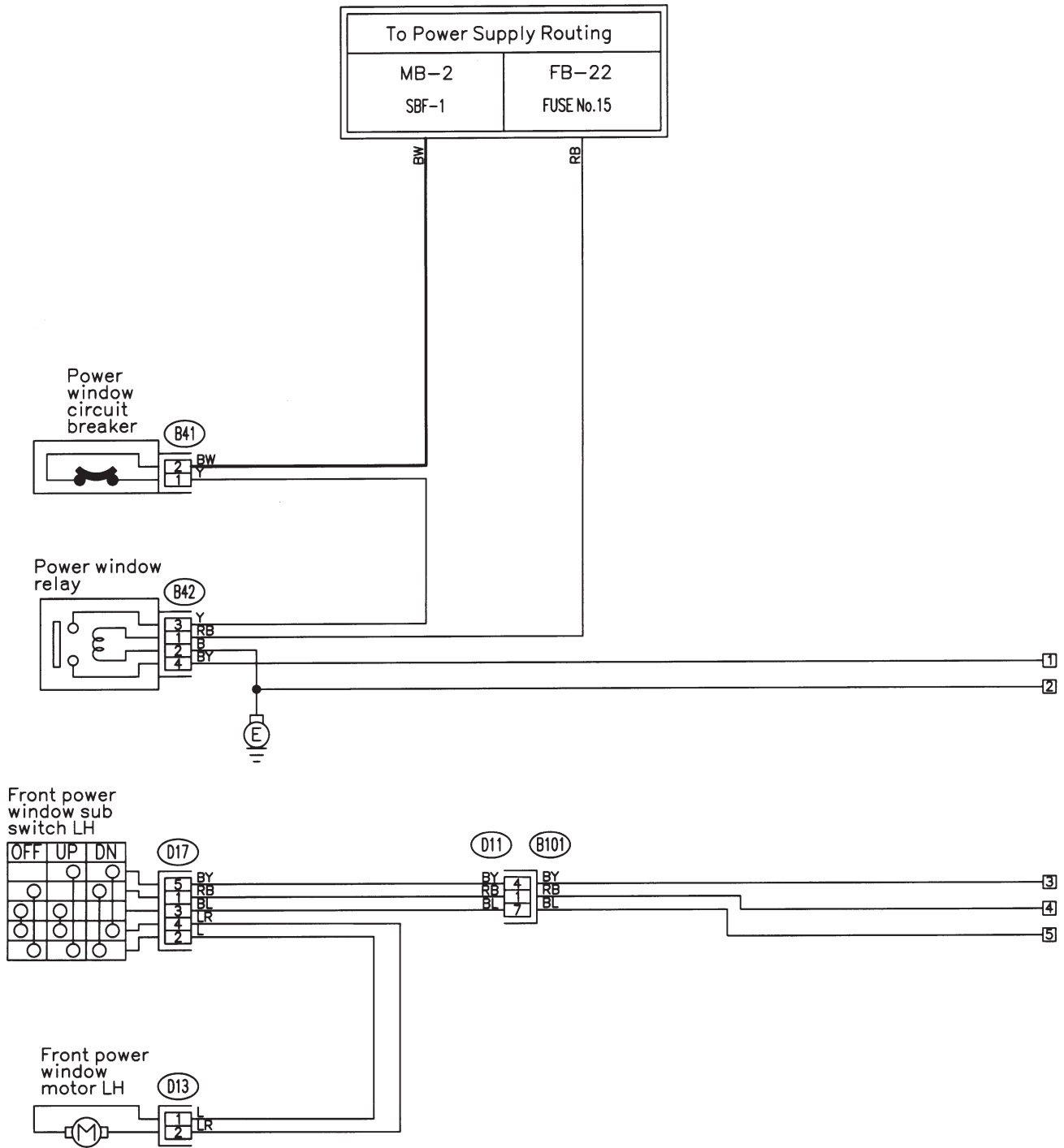

(Green) (B41)  
 (Green) (D3) (D13) (Green)  
 (Green) (D30) (D24) (Green)

(B42)

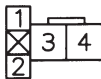
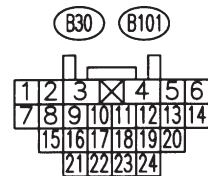

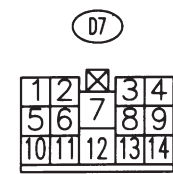
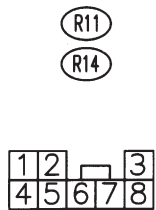
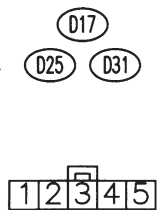
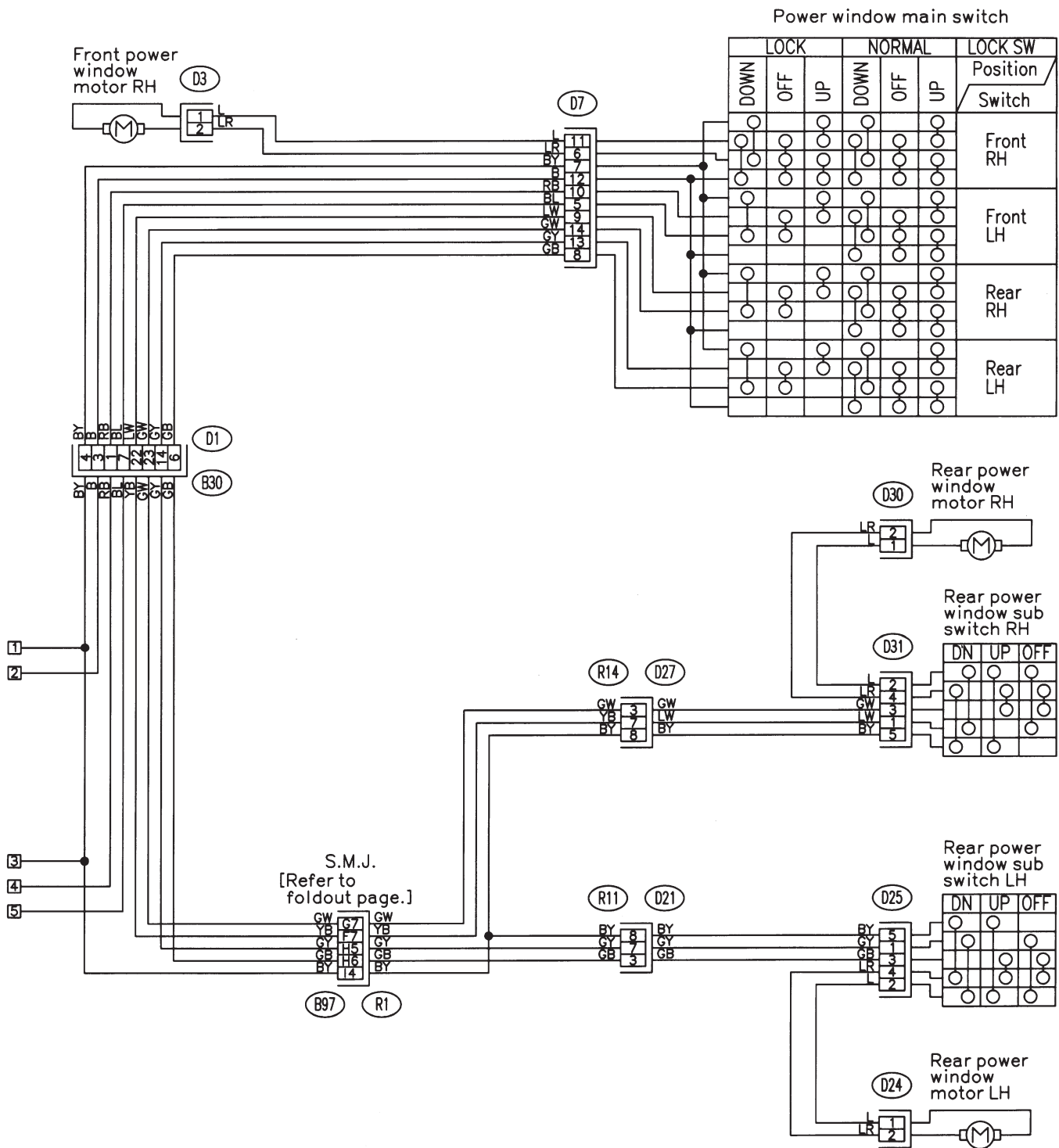

23. RADIATOR FAN SYSTEM

● LHD model

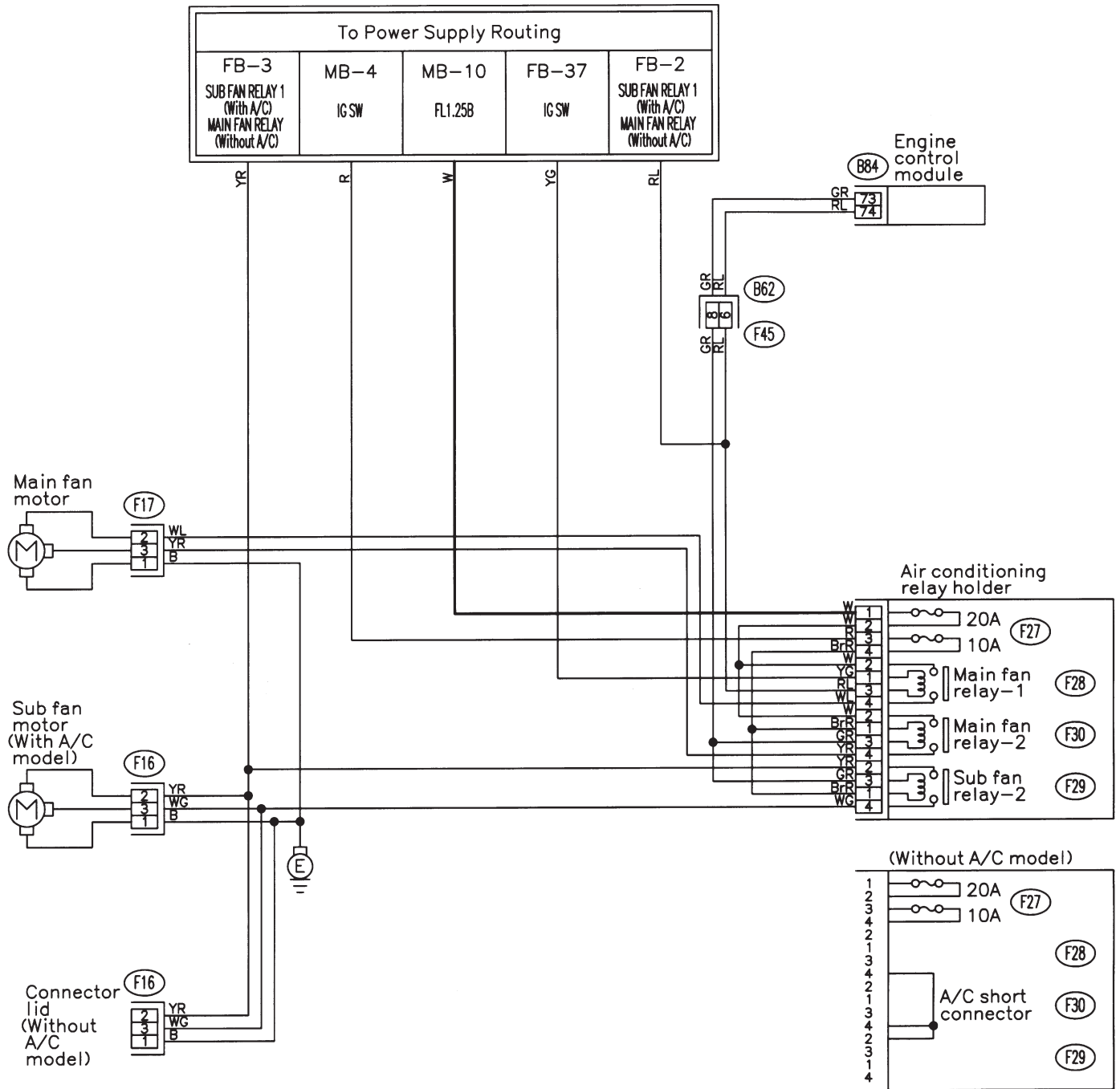

F16 (Black)

F17 (Black)

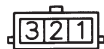

F45

B84 (Light blue)

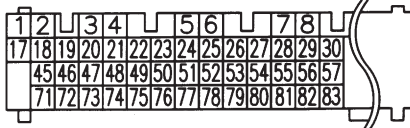

F27 F28 F29 F30 F31

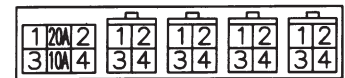

A/C relay holder (Black)



23. RADIATOR FAN SYSTEM

● RHD model

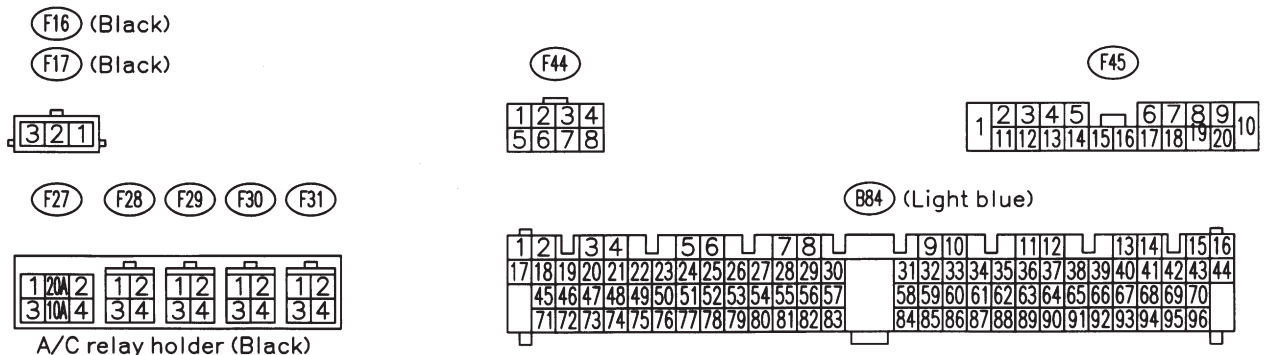
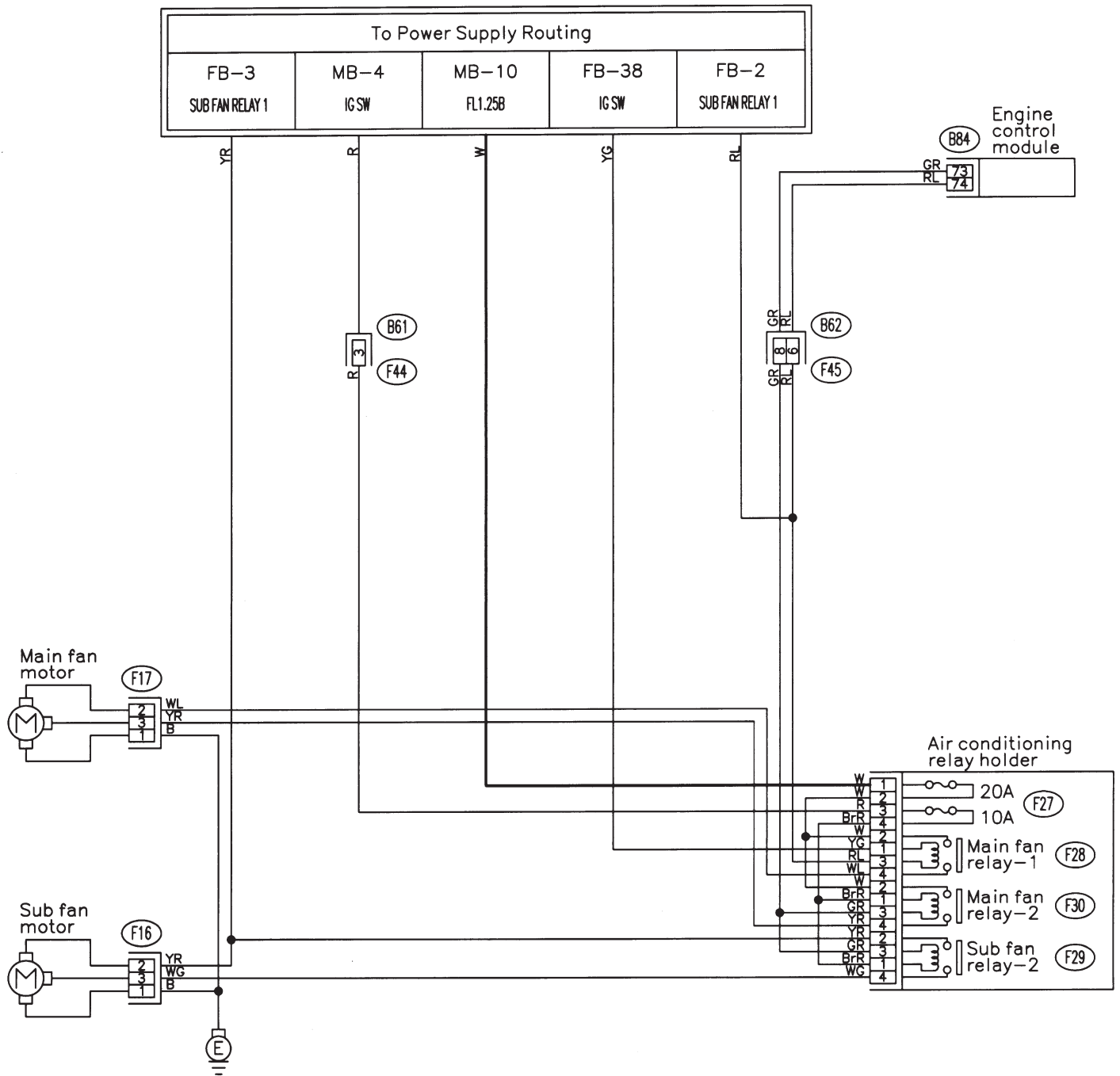

24. REAR WINDOW DEFOGGER SYSTEM

● LHD model

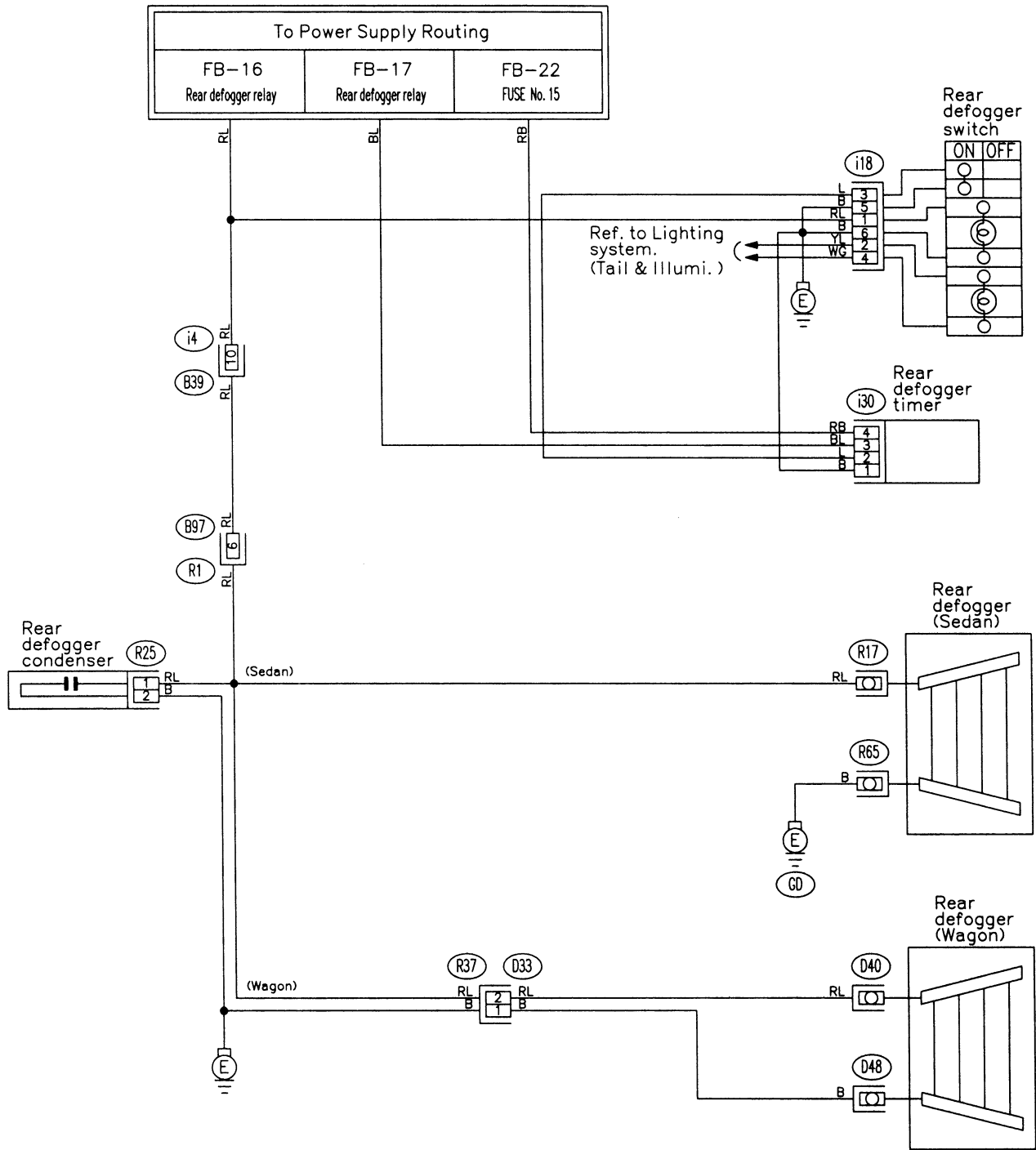

(D33)

(R25) (Black)

(i18)

(i30)

(B97)

(i4) (Blue)

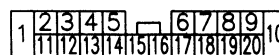
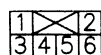



24. REAR WINDOW DEFOGGER SYSTEM

- RHD model

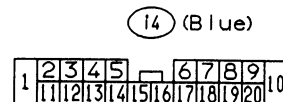
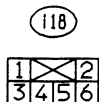
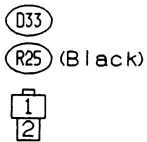
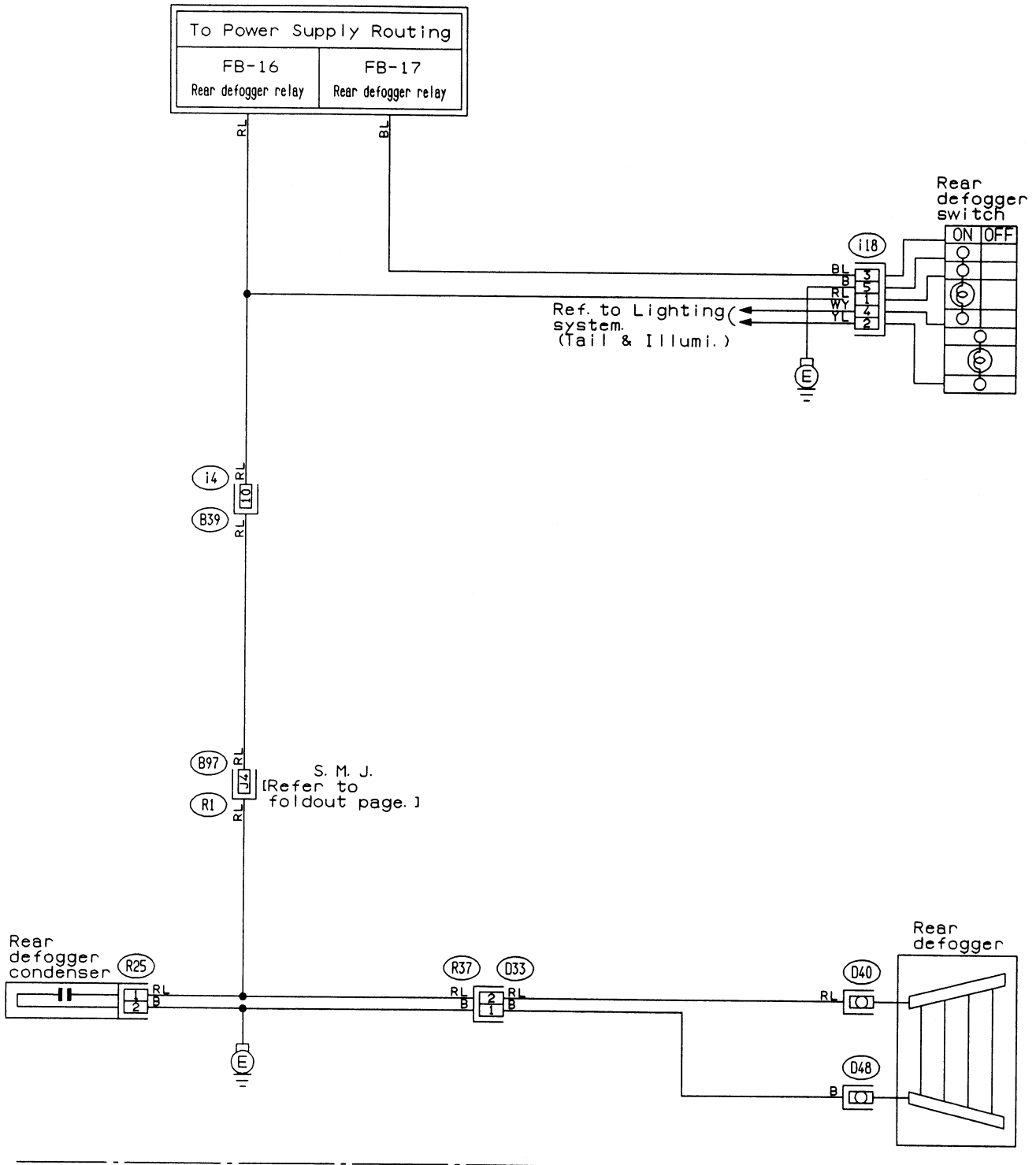

25. REAR WIPER AND WASHER SYSTEM

● LHD model

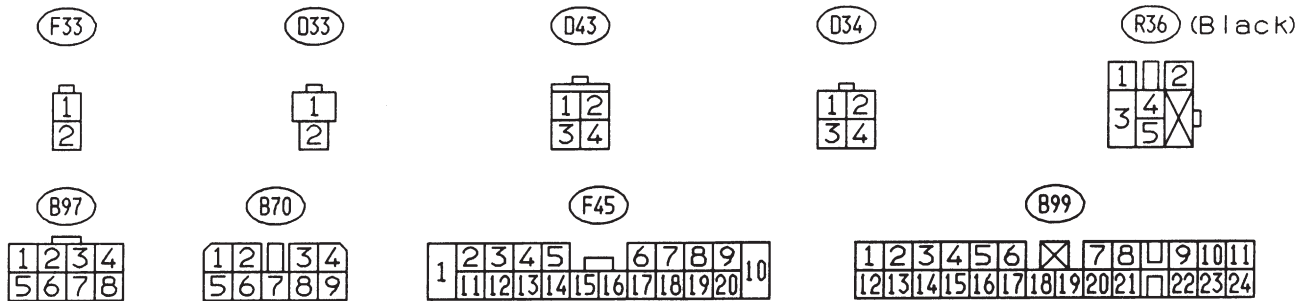
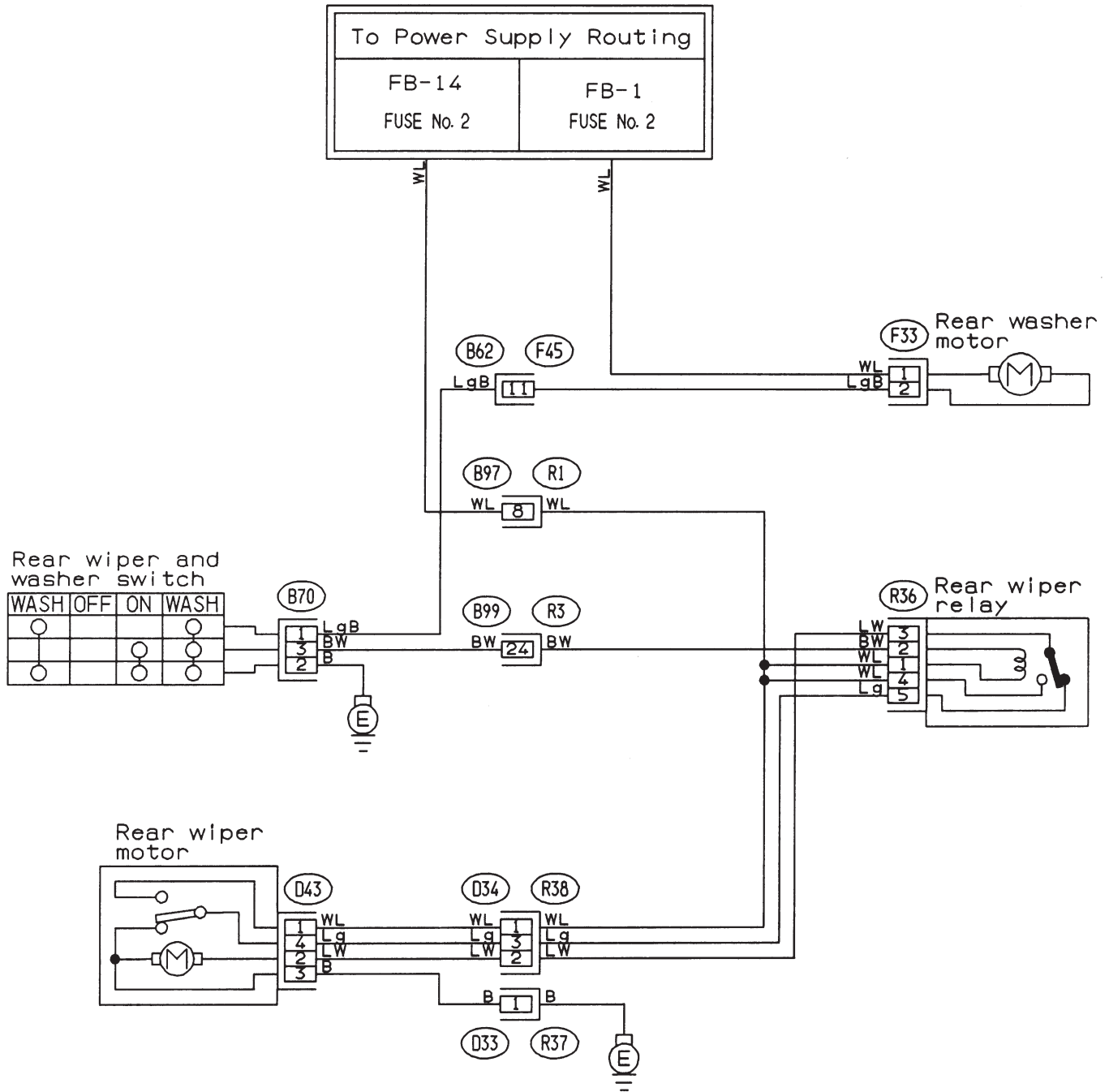

BU51-02

25. REAR WIPER AND WASHER SYSTEM

• RHD model

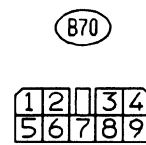
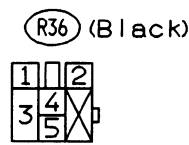
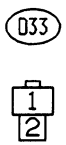
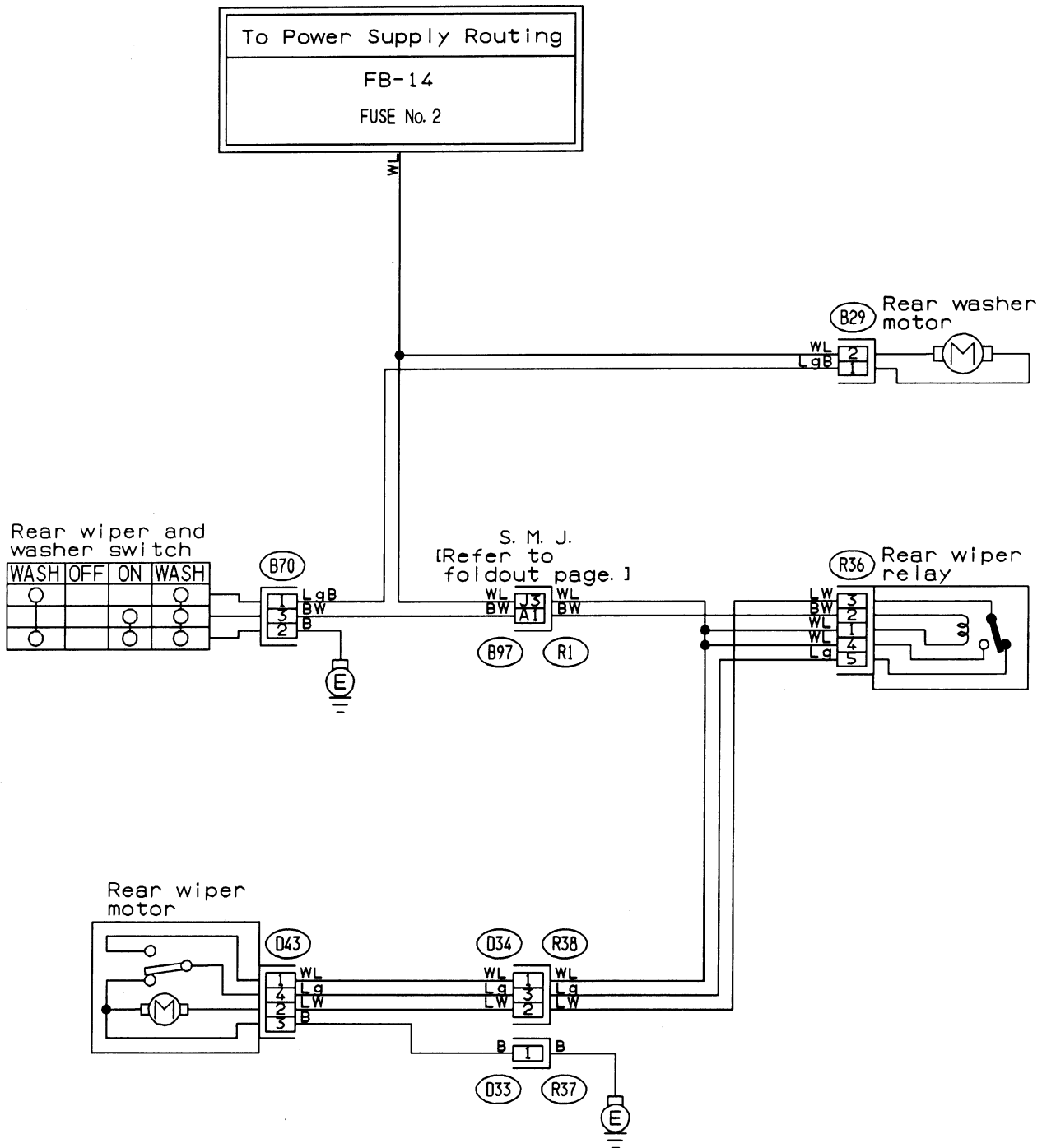

26. REMOTE CONTROL REARVIEW MIRROR SYSTEM

● LHD model

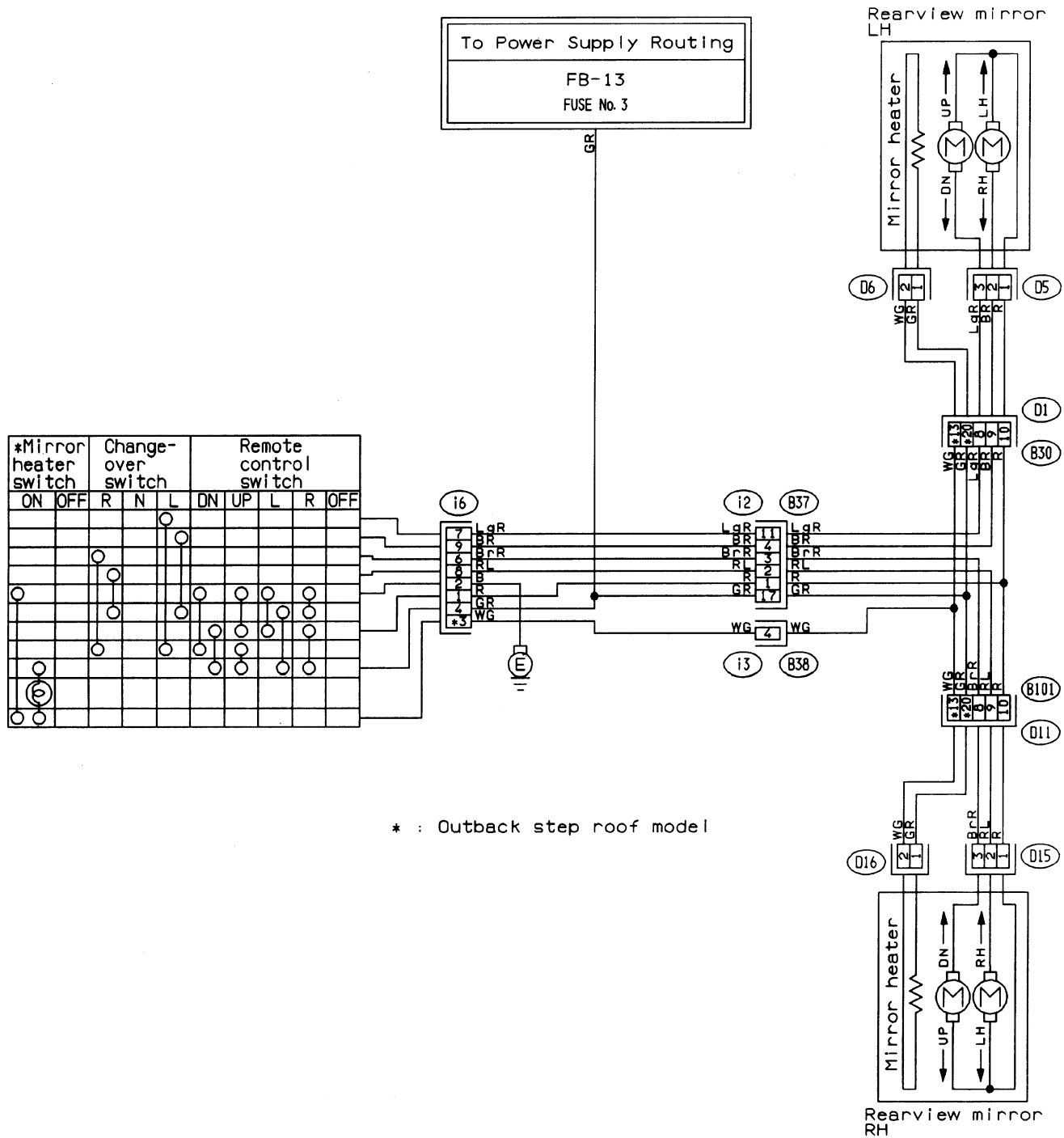

\* : Outback step roof model



26. REMOTE CONTROL REARVIEW MIRROR SYSTEM

- RHD model

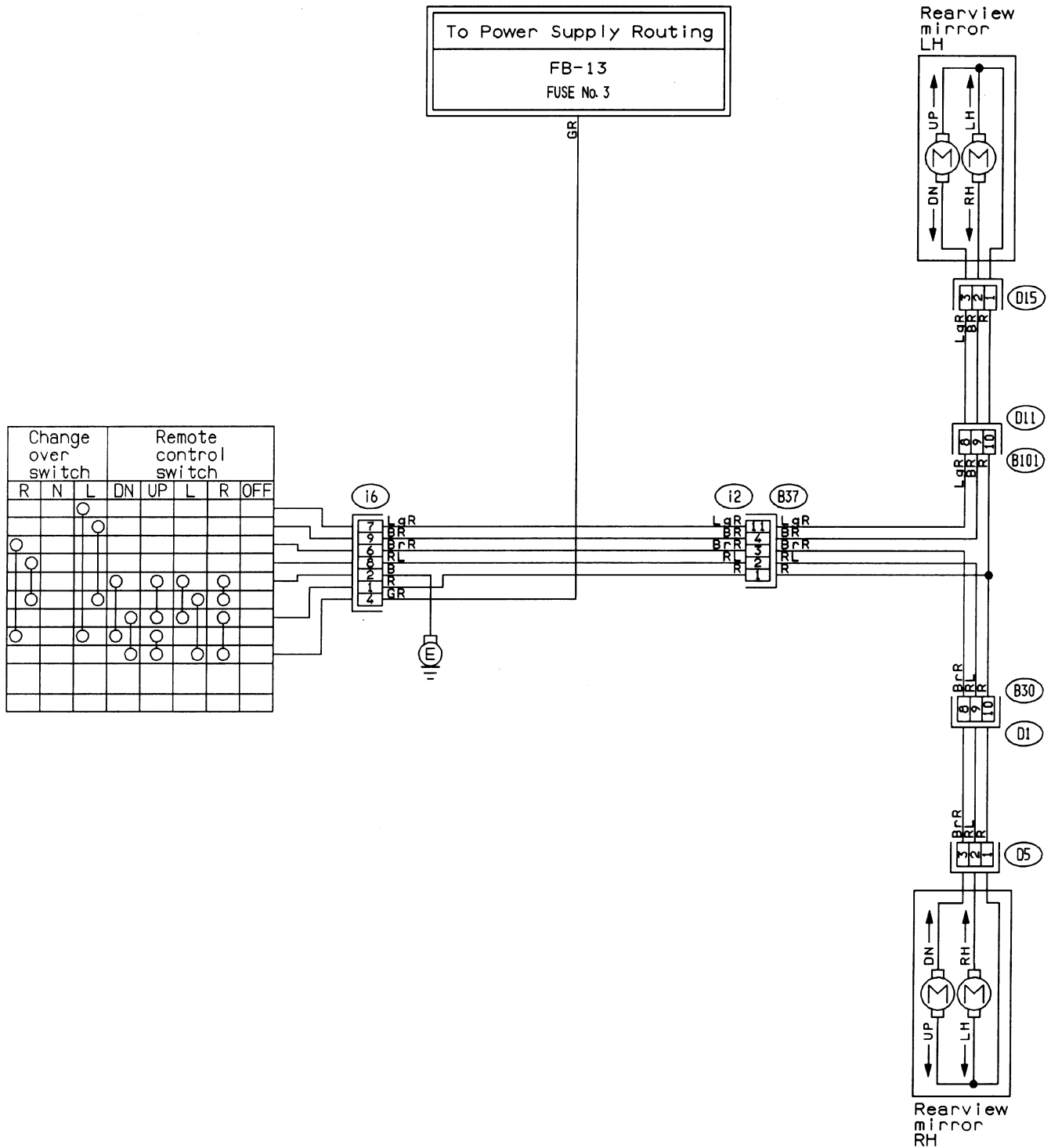

(D5) (D15)

(i6)

(i2)

(B30) (B101)

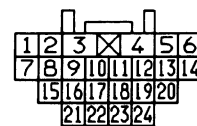
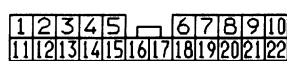
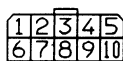

27. SEAT BELT WARNING SYSTEM

● LHD model

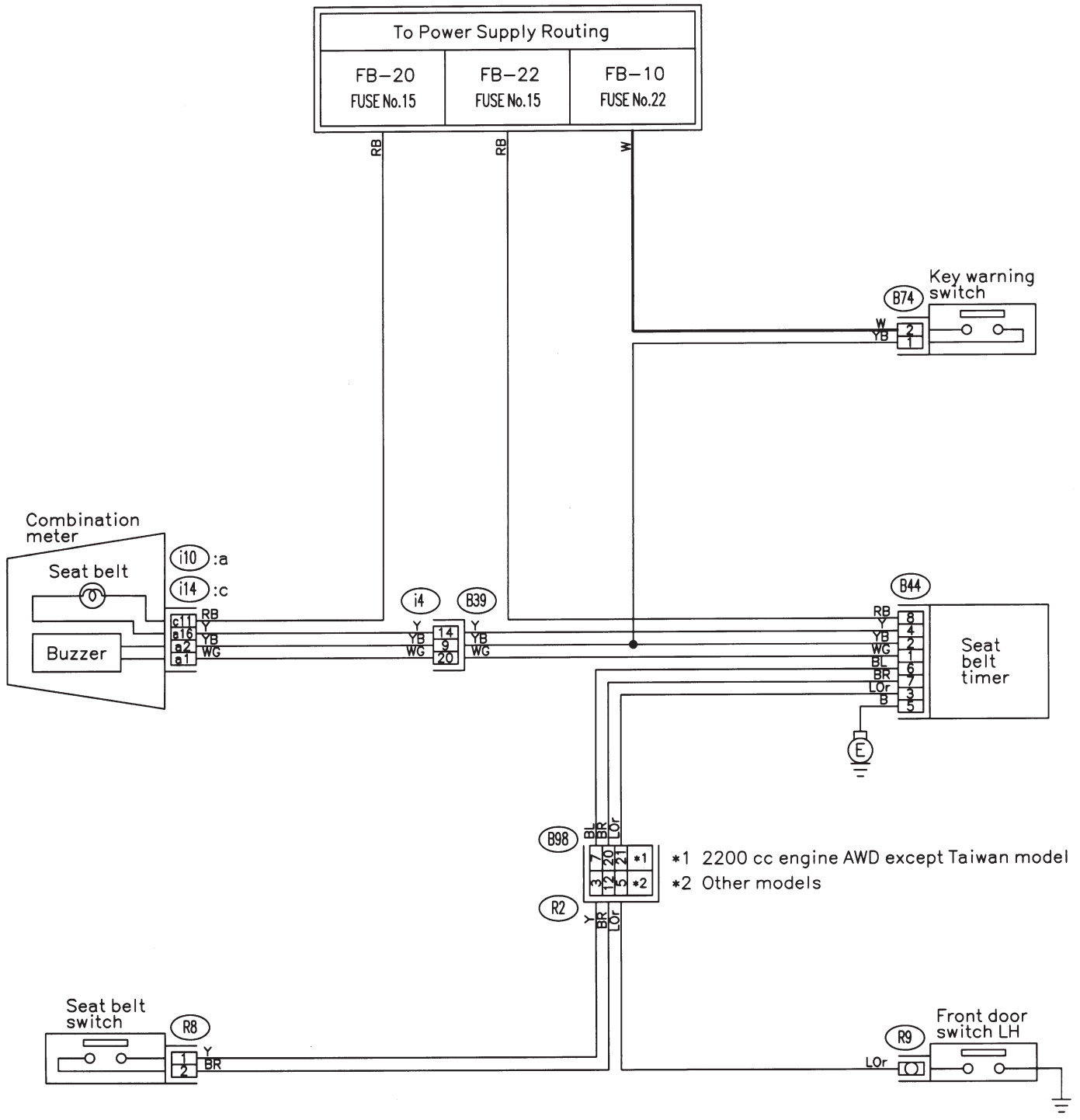

(R8) (B74) (Black)



(B44)



(i4) (Blue)



(i14)

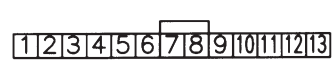

(i10) (Light gray)

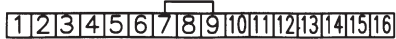

(\*1 • Black)

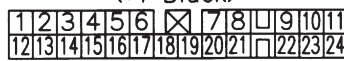

(B98)

(\*2)

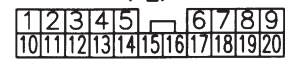

27. SEAT BELT WARNING SYSTEM

● RHD model

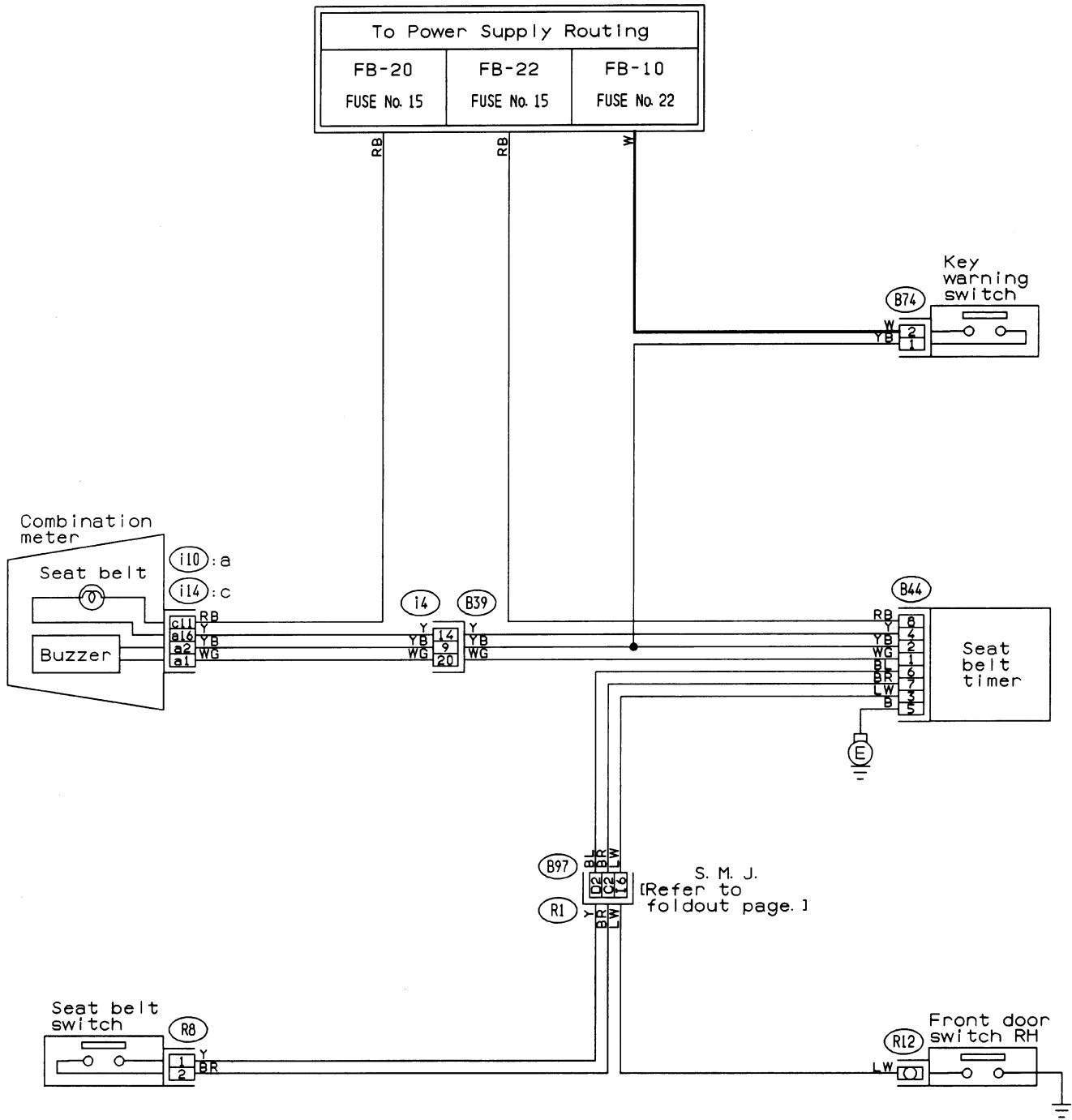

(R8) (B74) (Black)



(B44)

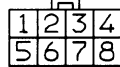

(i14)

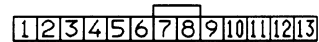

(i10) (Light gray)

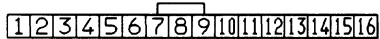

(i4) (Blue)

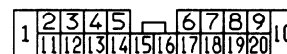

28. SECURITY SYSTEM

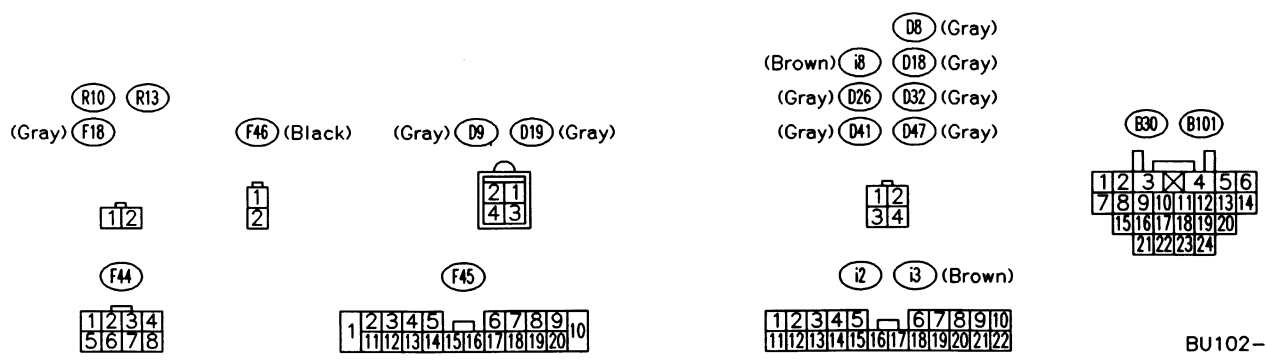
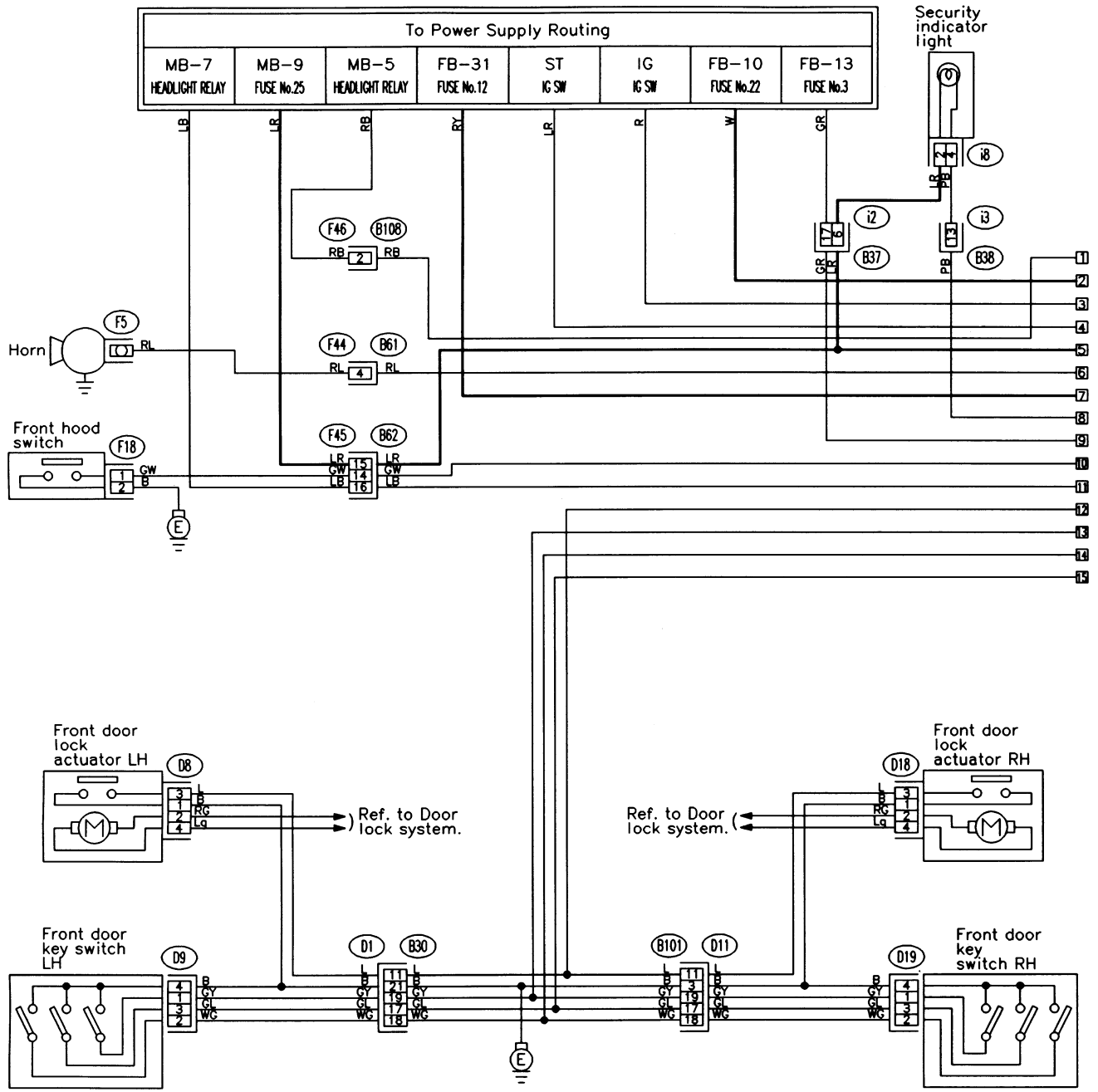

BU102-03A



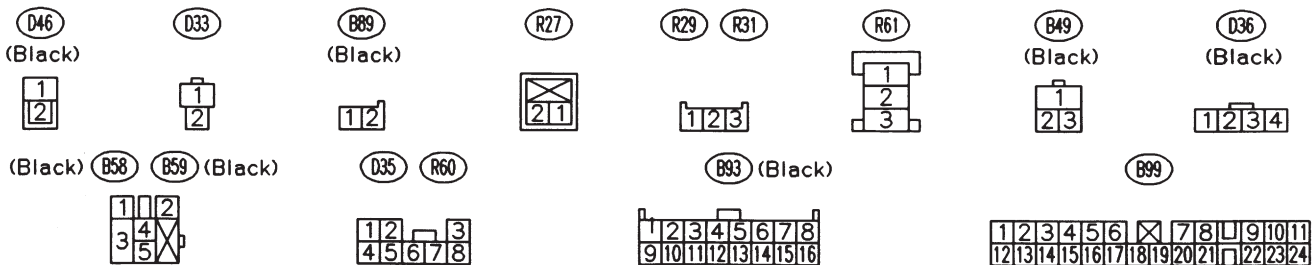
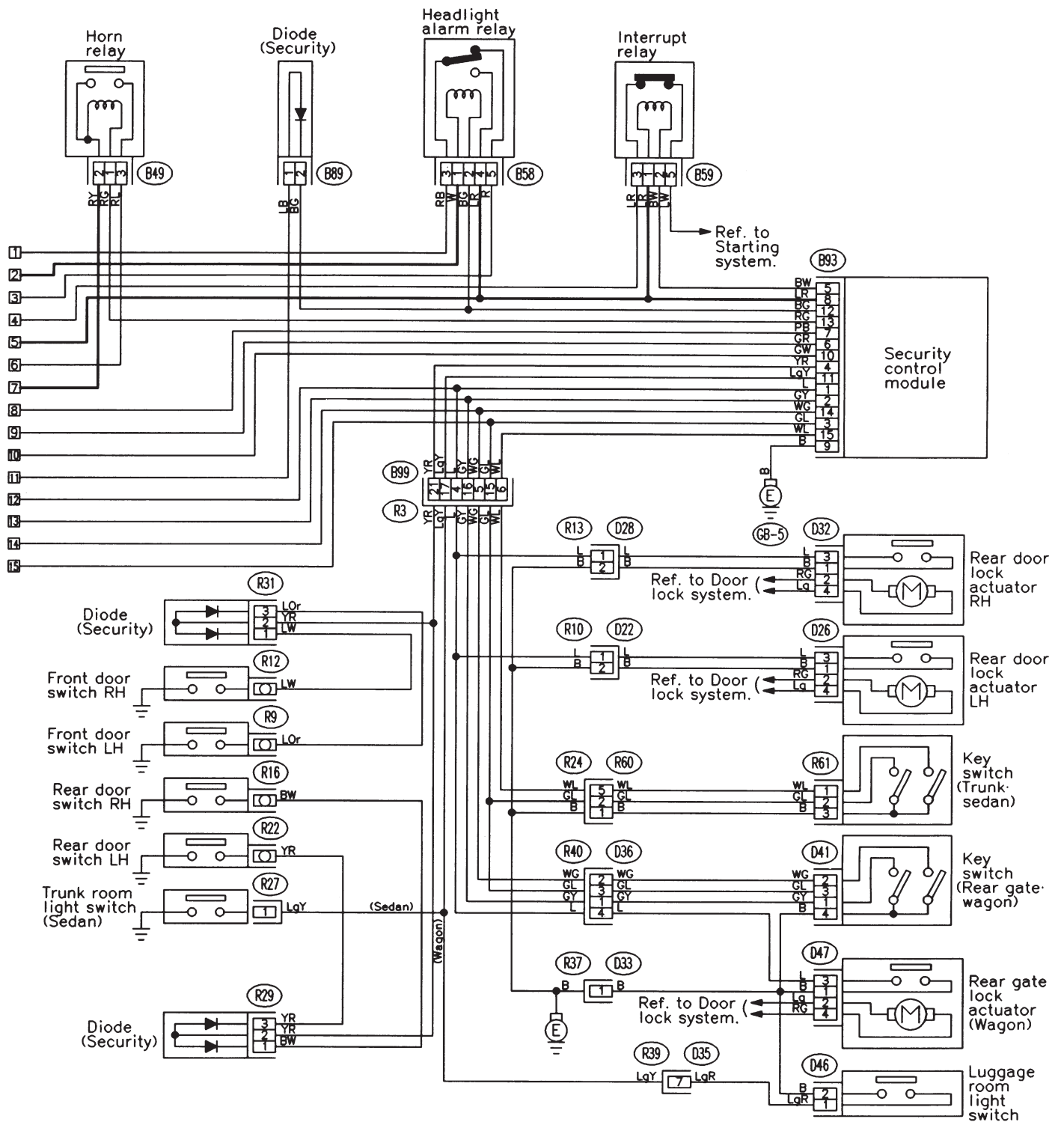

29. SPOT LIGHT, ROOM LIGHT, LUGGAGE AND TRUNK ROOM LIGHT SYSTEM

● LHD model

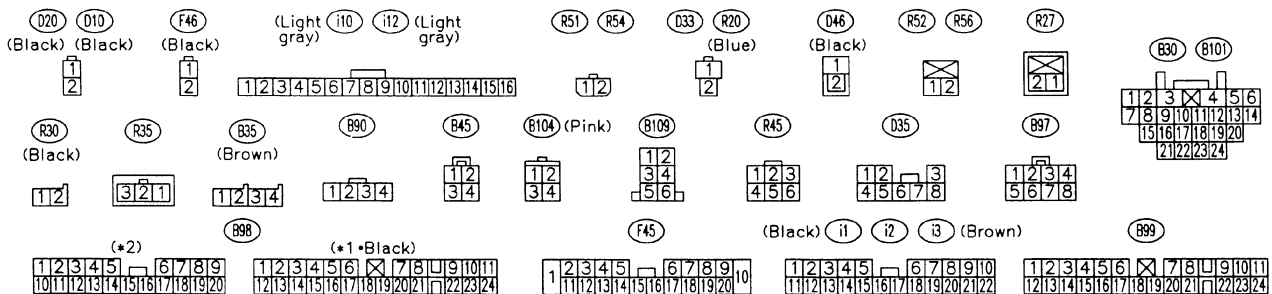
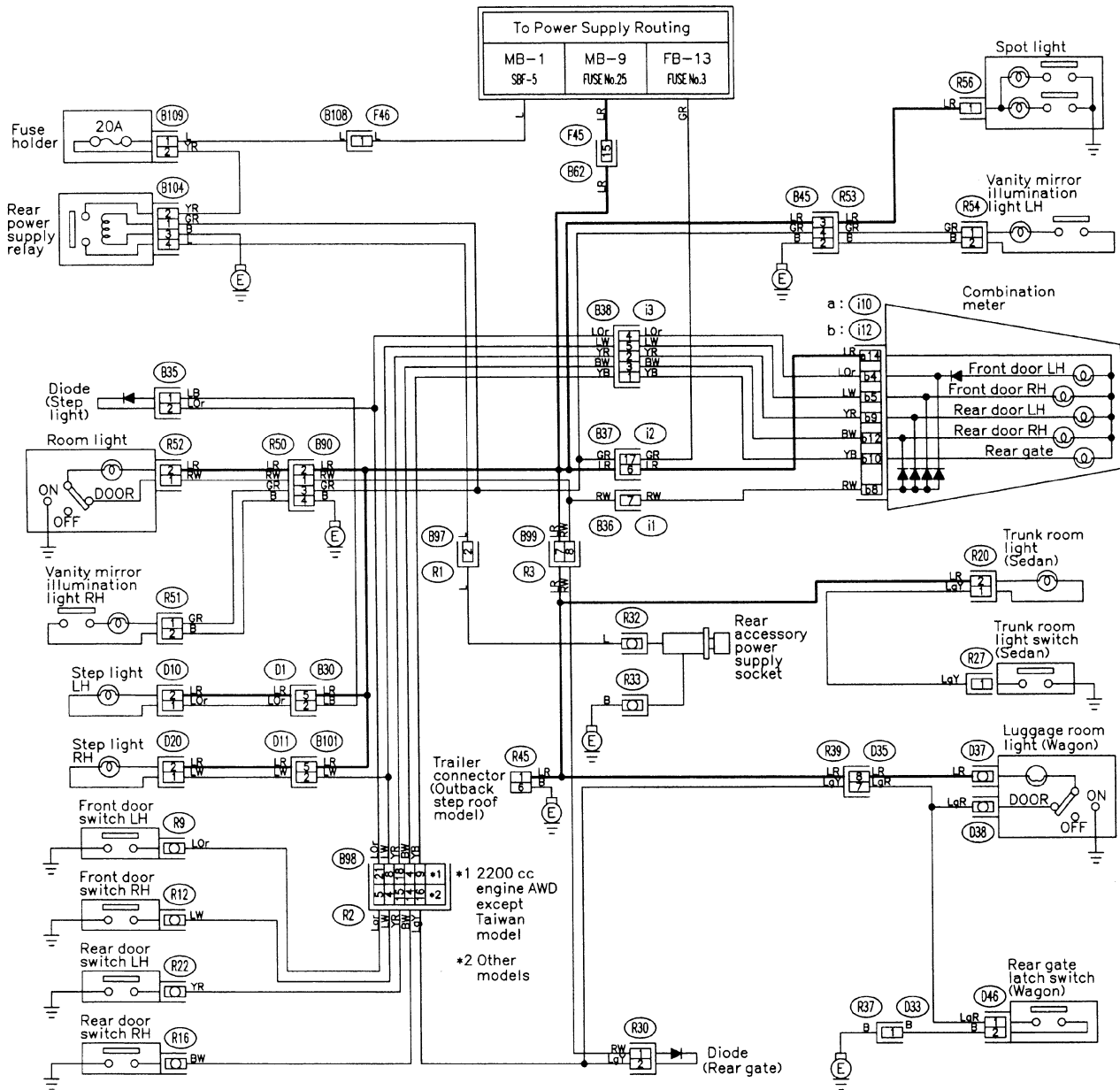

29. SPOT LIGHT, ROOM LIGHT, LUGGAGE AND TRUNK ROOM LIGHT SYSTEM

● RHD model

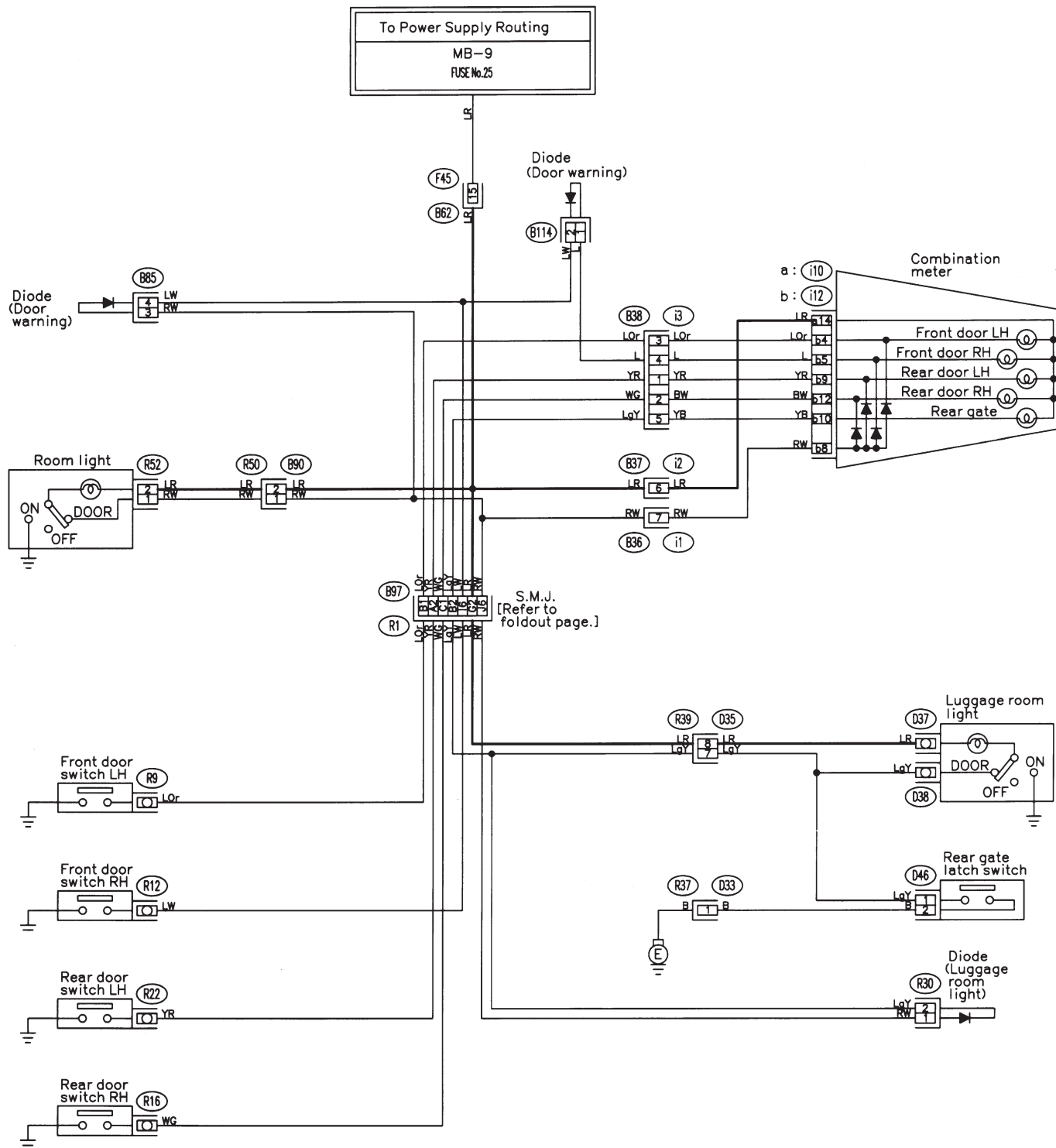

- (B114) (Black)
- (R30) (Black)
- (D33) (D39) (Green)
- (D46) (Black)
- (R52)
- (B85) (Brown)
- (D35)
- (Light gray) (i10) (i12) (Light gray)
- (F45)
- (Black) (i1) (i2)

30. SRS (AIRBAG SYSTEM)

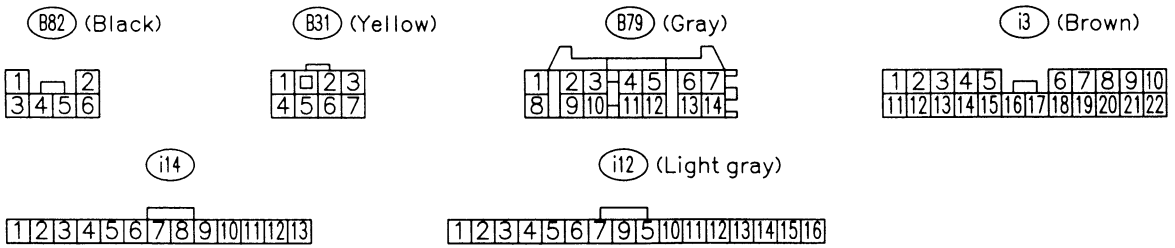
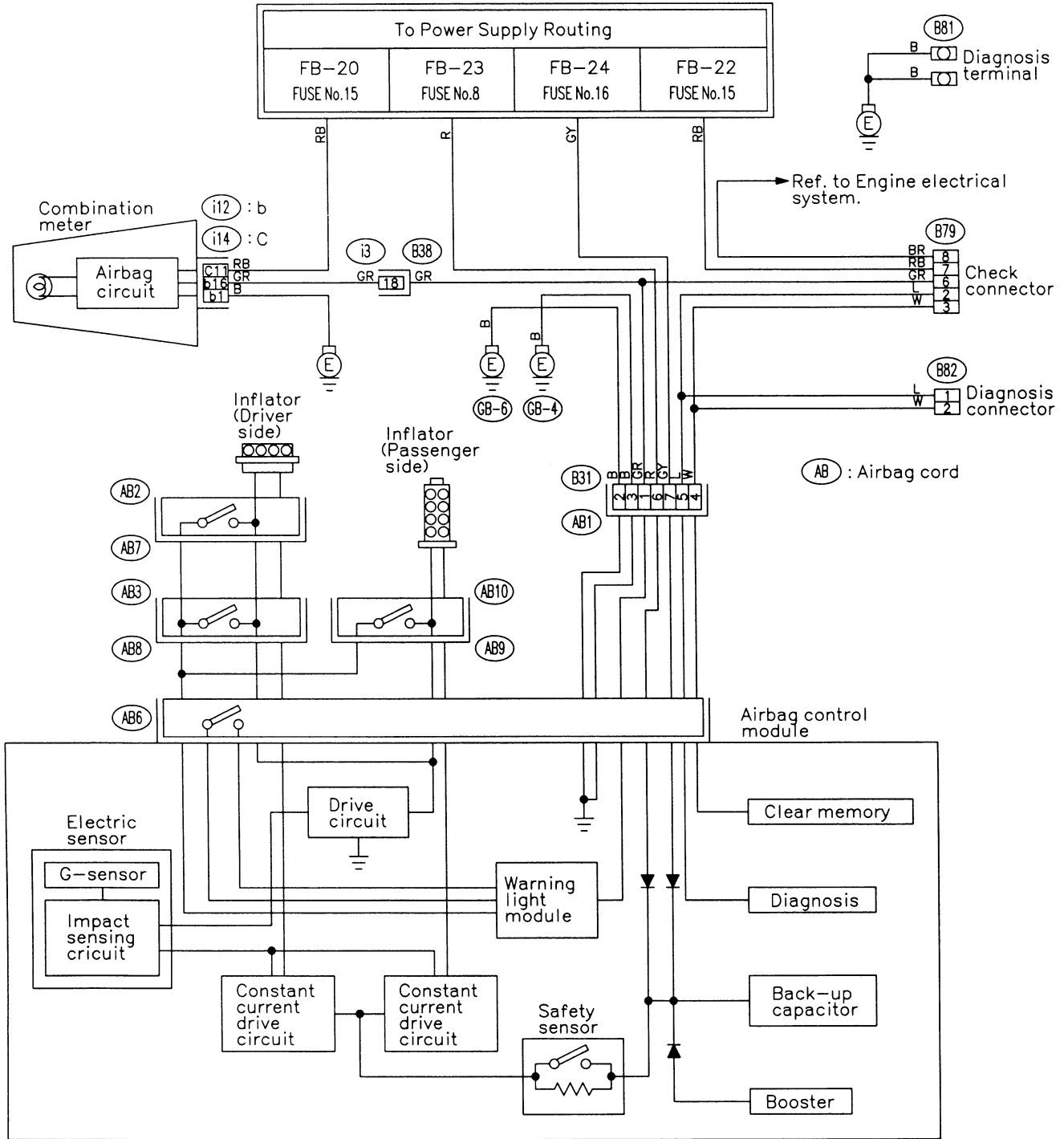

### 31. STARTING SYSTEM

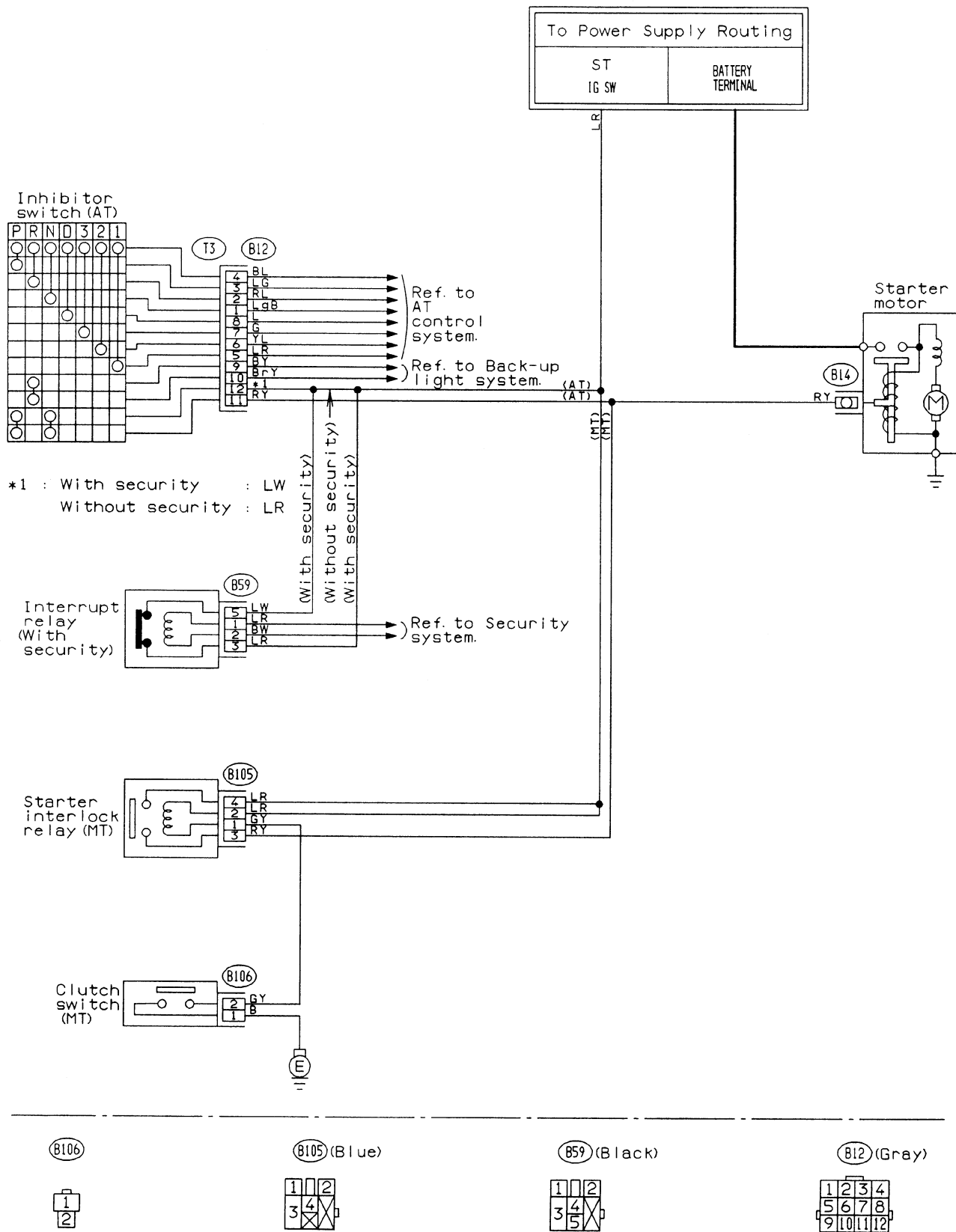

32. STOP LIGHT SYSTEM

● LHD model

- \*1 : Without cruise control
- \*2 : With cruise control
- \*3 : With T. C. S.
- \*4 : Sedan
- \*5 : Wagon

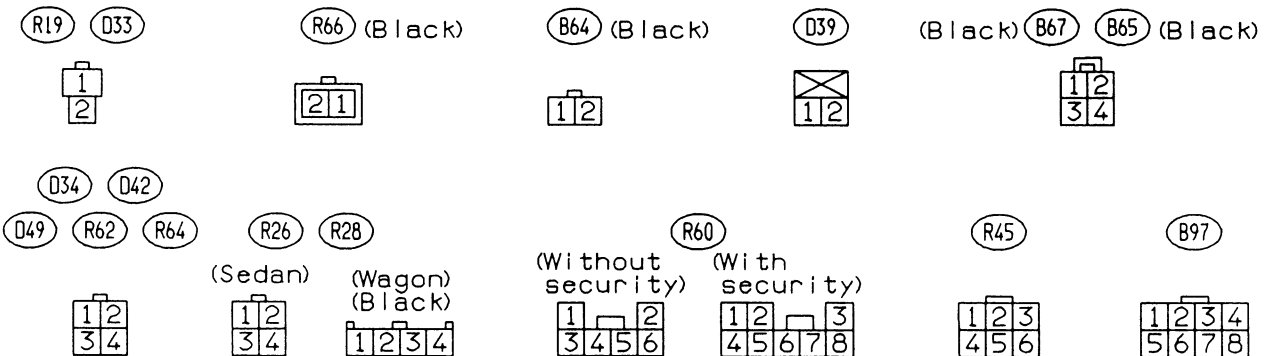
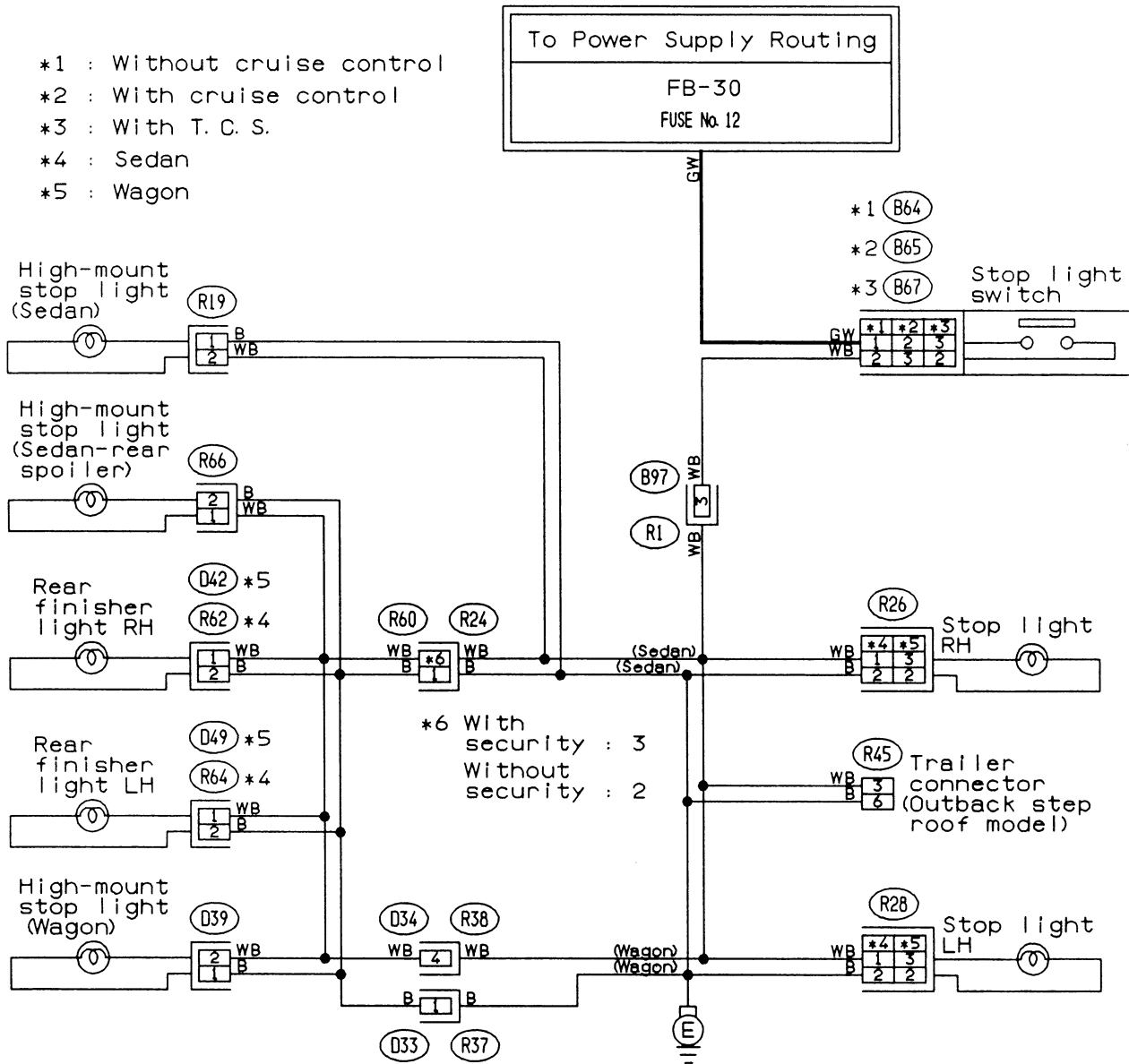

32. STOP LIGHT SYSTEM

● RHD model

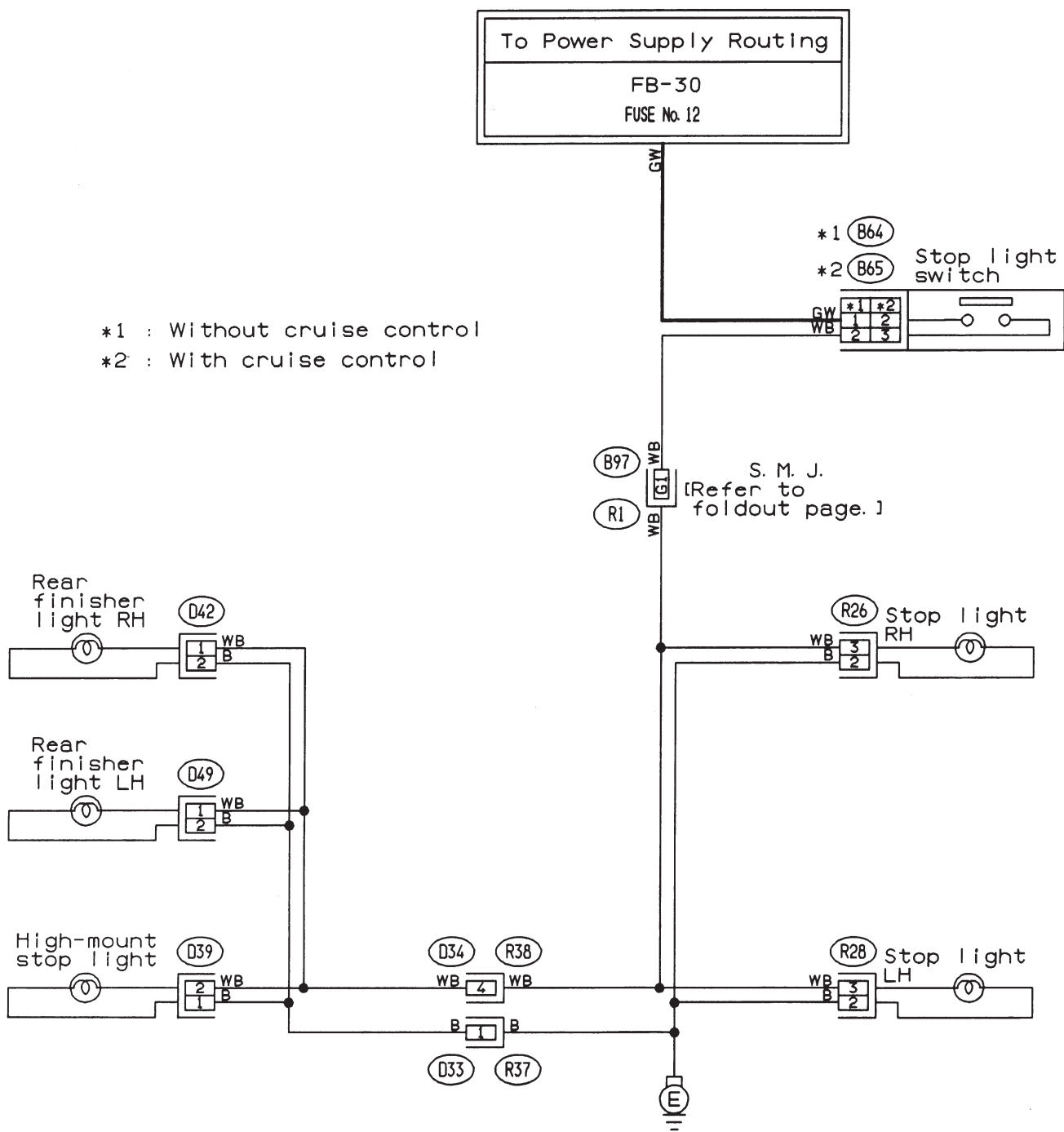

\*1 : Without cruise control  
\*2 : With cruise control

S. M. J.  
[Refer to foldout page.]

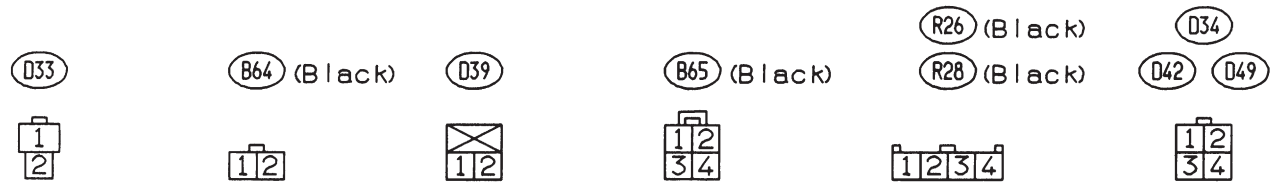

BUR25-01

33. SUNROOF SYSTEM

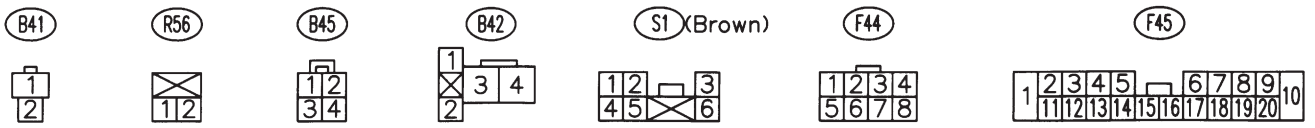
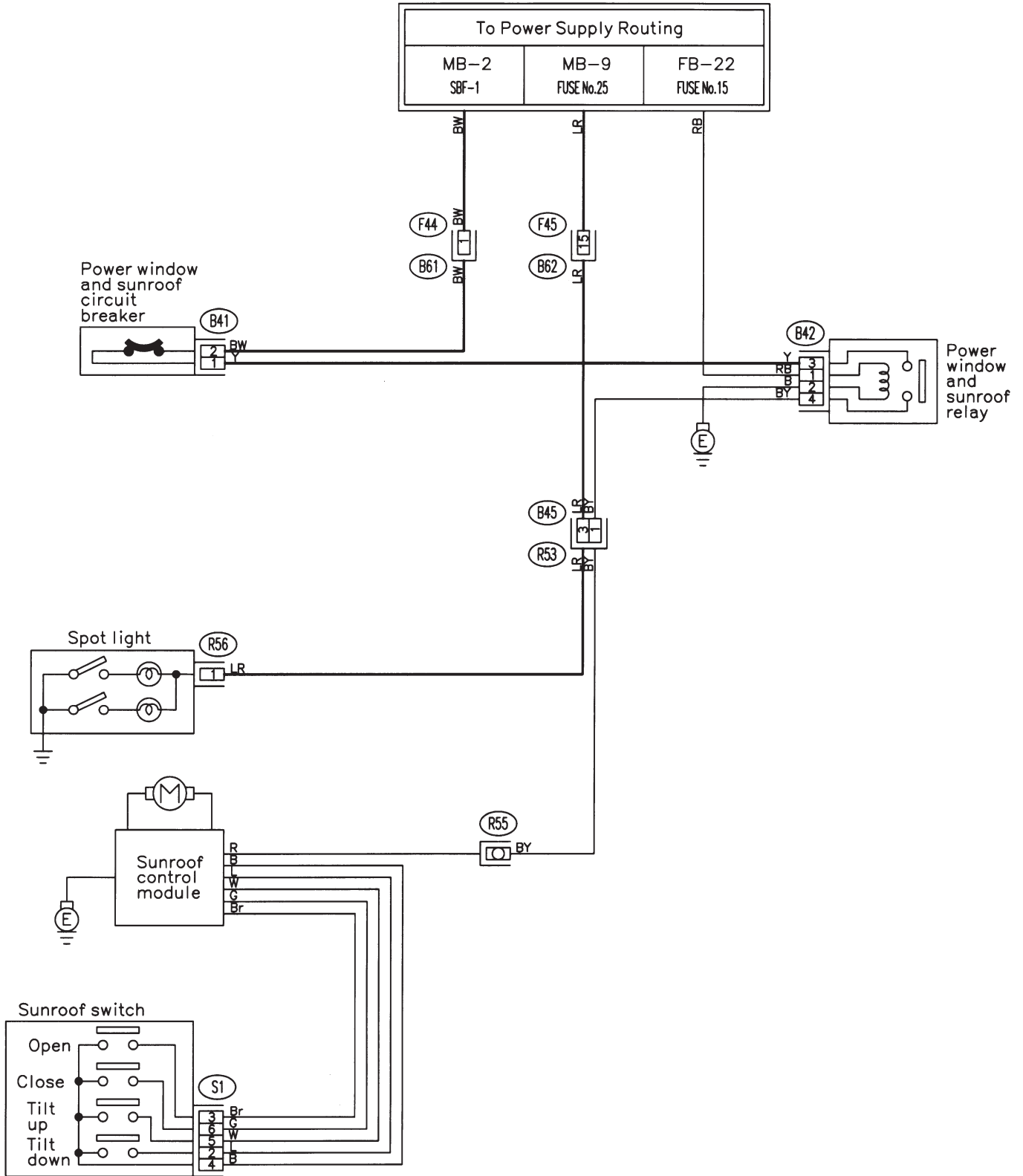



34. TRACTION CONTROL SYSTEM

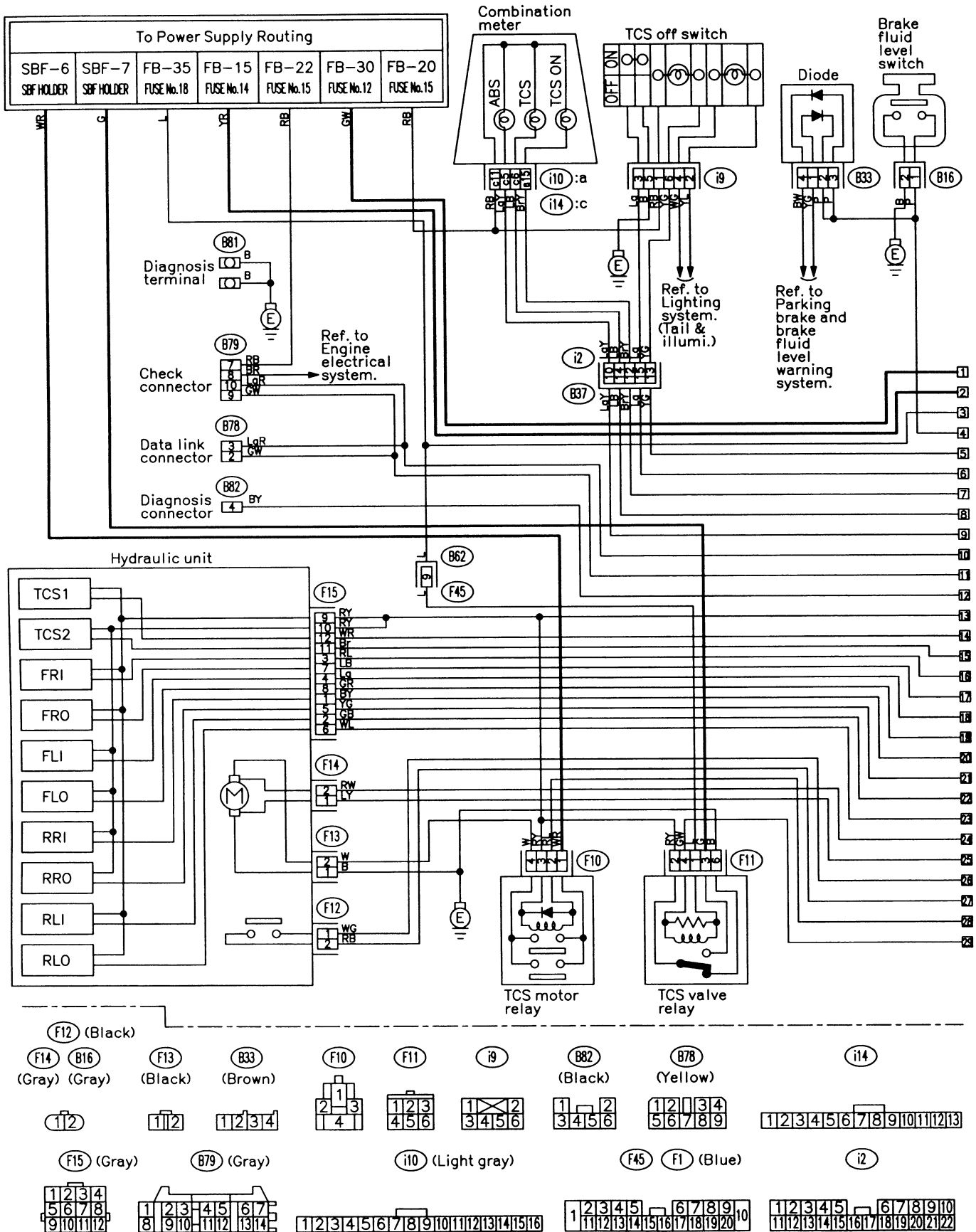

6. Wiring Diagram

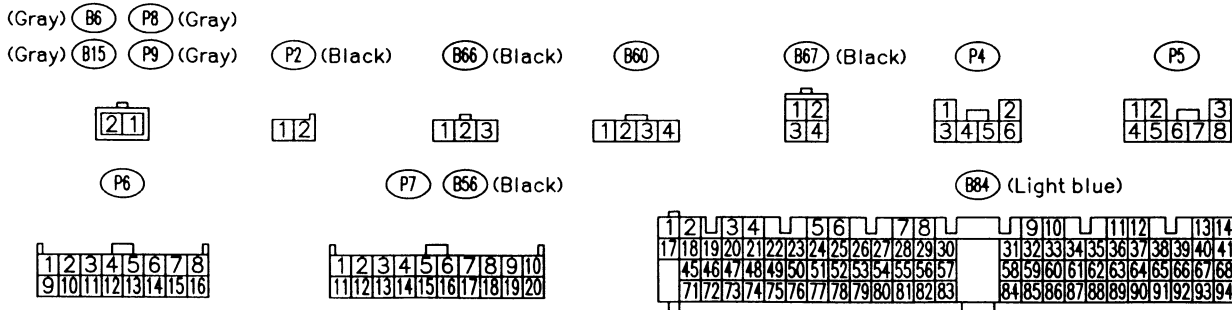
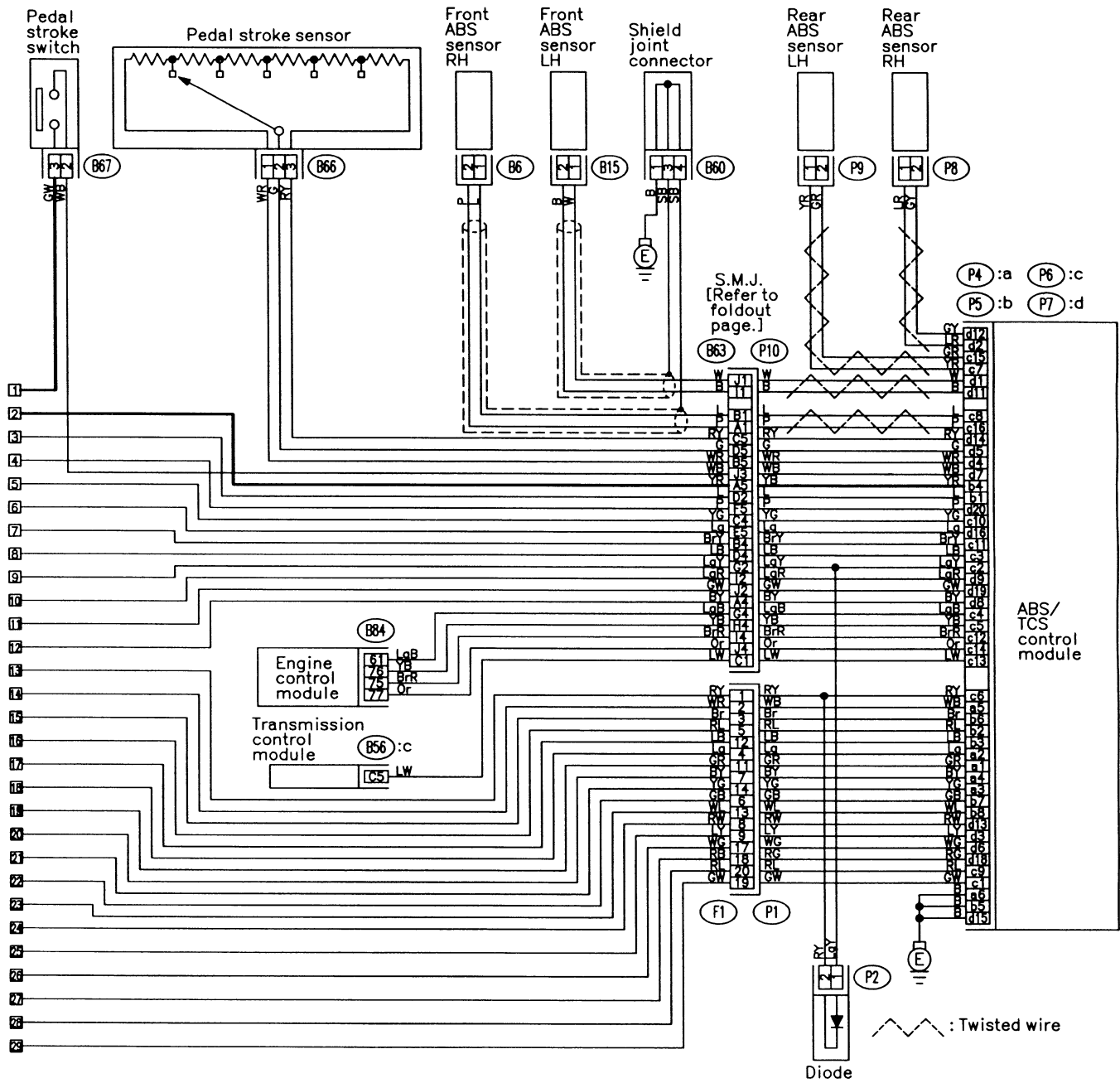

35. TURN SIGNAL AND HAZARD SYSTEM

● LHD model

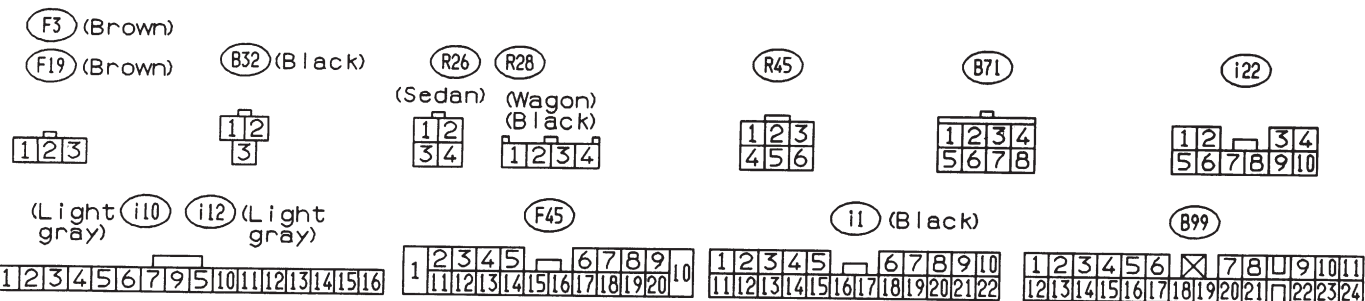
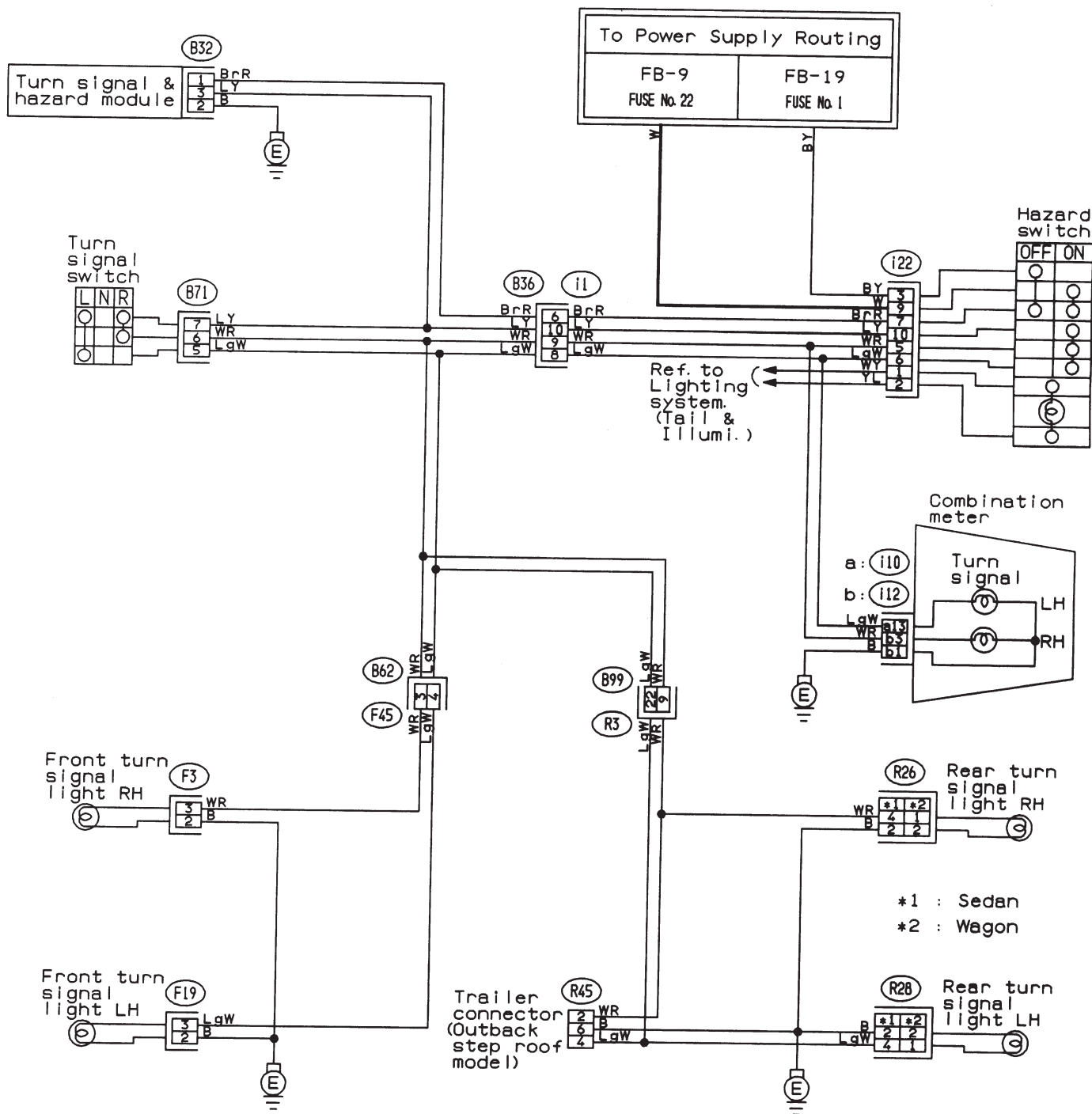

35. TURN SIGNAL AND HAZARD SYSTEM

● RHD model

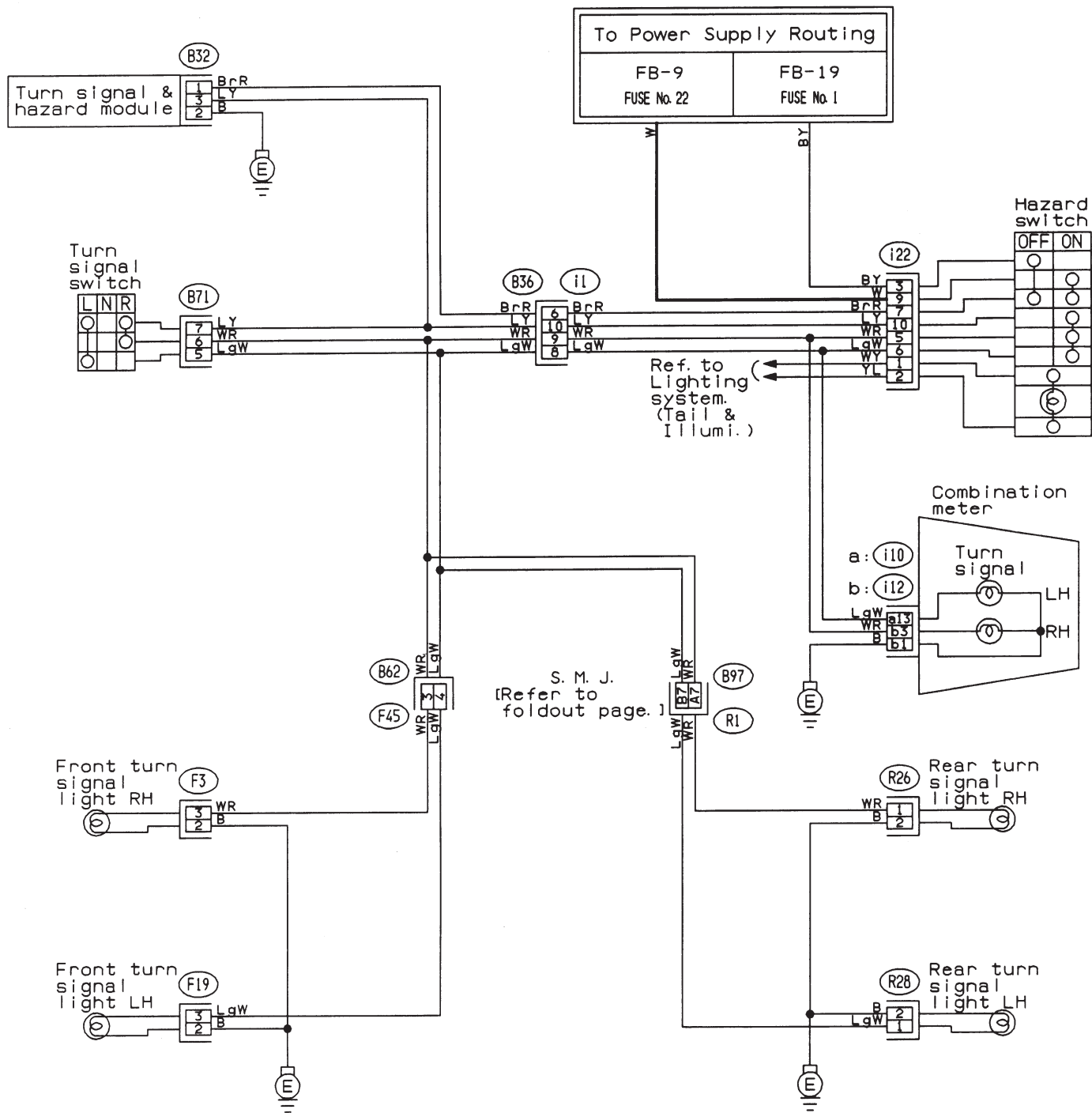

F3 (Brown)

F19 (Brown)

B32 (Black)

R26 (Black)

R28 (Black)

B71

i22

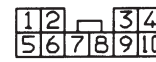
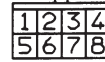
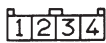

(Light gray) i10 i12 (Light gray)

F45

i1 (Black)

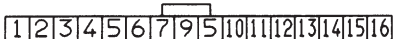

36. SEAT HEATER SYSTEM

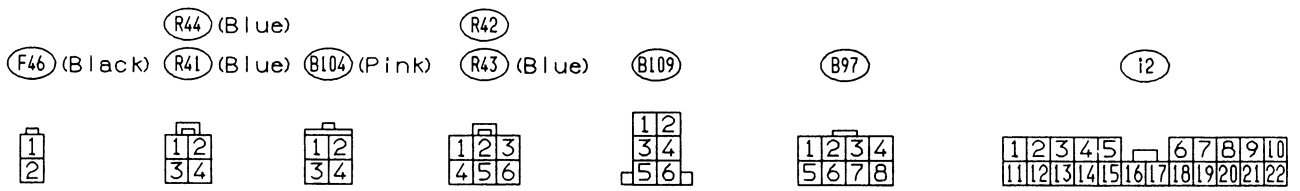
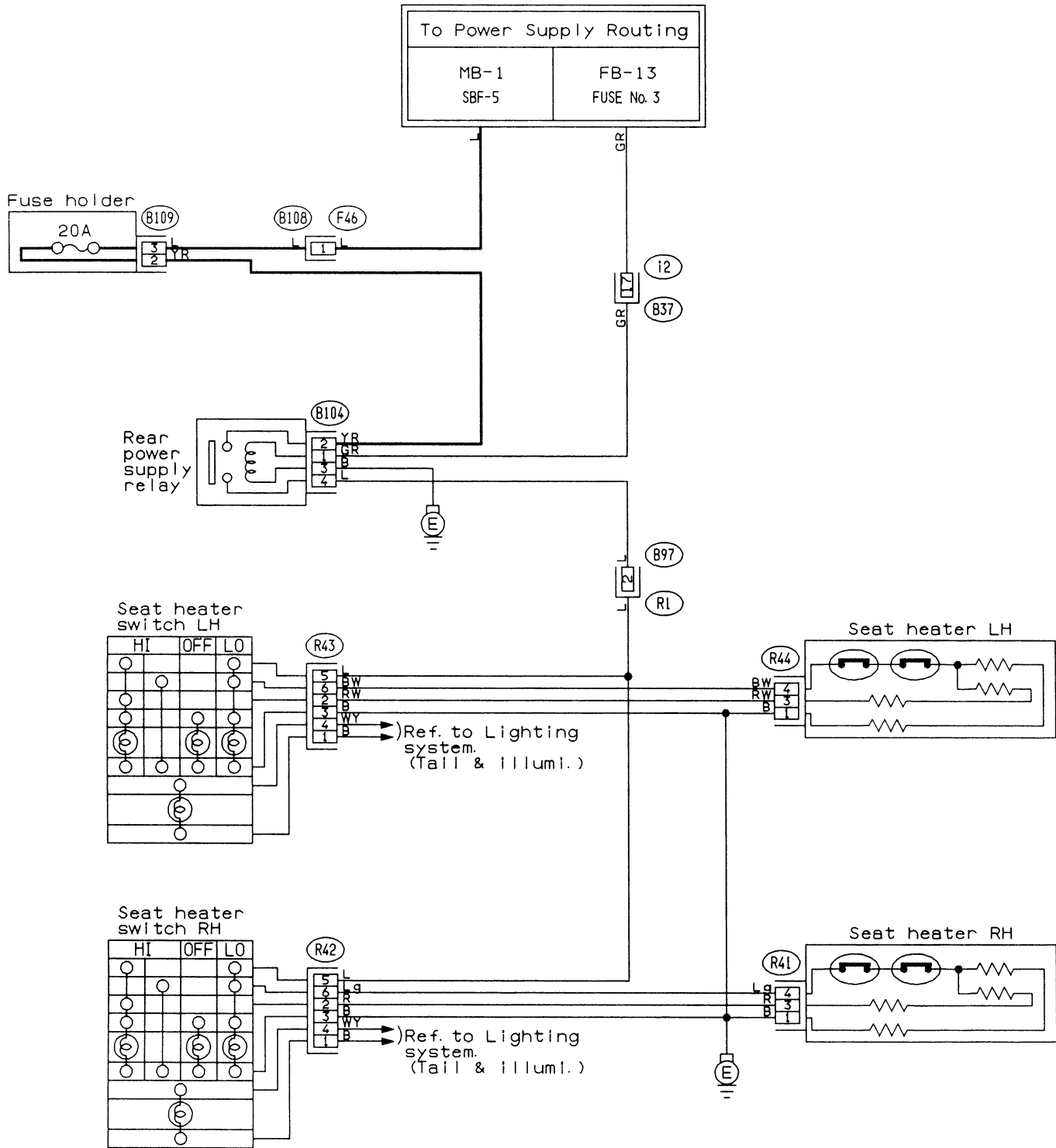

## 7. Electrical Unit Location

Electrical unit	Refer to;
A.B.S. control module	4-4a [T300]
A.B.S. G sensor (MT)	4-4a [T300]
A/C compressor relay	⑦
A/C fuse	⑪
A/C main fan relay 1	⑩
A/C main fan relay 2	⑧
A/C pressure switch	②
A/C sub fan relay 2	⑨
ATF temperature sensor	2-7 [T2B1]
Blower motor resistor	⑫
Blower relay	⑬
Camshaft position sensor	2-7 [T2A2]
Check connector	⑮
Clutch switch (MT)	6-2 [T300]
Crankshaft position sensor	2-7 [T2A2]
Cruise control module	6-2 [T300]
Cruise control pump	6-2 [T300]
Data link connector (for OBD-II G.S.T.)	2-7 [T2A1]
Data link connector (for S.S.M.)	2-7 [T2A1]
Diagnosis connector	4-4a [T300]
Diagnosis terminal (Ground)	4-4a [T300]
Door lock timer	⑰
Engine control module	2-7 [T2A1]
Engine coolant temperature sensor	2-7 [T2A2]
Engine hood switch (Security)	6-2 [K6A0]
Evaporator thermostwitch	⑲
F/B	⑮
FRESH/RECIRC actuator	⑳
Fuel pump relay	2-7 [T2A3]
Fuel gauge module	⑳
Fuel gauge sub module (AWD)	㉑
FWD switch (AT)	①
Headlight alarm relay (Security)	6-2 [K6A0]
Headlight relay LH	⑤
Headlight relay RH	⑥
Horn relay	⑭

Electrical unit	Refer to;
Hydraulic unit (A.B.S.)	4-4a [T300]
Ignition coil	2-7 [T2A3]
Ignitor	2-7 [T2A3]
Idle air control solenoid valve	2-7 [T2A3]
Illumination control module	㉒
Inhibitor switch	6-2 [T300]
Knock sensor	2-7 [T2A2]
Main fan relay	⑬
Main relay	2-7 [T2A3]
Mass air flow sensor	2-7 [T2A2]
Mode actuator	⑲
M/B	④
Oil pressure switch	③
Oxygen sensor	2-7 [T2A2]
Pedal stroke sensor (T.C.S.)	4-4b [T300]
Power window and sunroof relay	㉓
Power window circuit breaker	㉔
Purge control solenoid valve	2-7 [T2A3]
Rear defogger relay	⑰
Seat belt timer	㉕
Security control module	6-2 [K6A0]
Shift lock control module	㉖
Starter interrupt relay (Security)	6-2 [K6A0]
Stop & brake switch (With cruise control)	6-2 [T300]
Sunroof control module	㉗
Tail and illumination relay	⑱
T.C.S. control module	4-4b [T300]
T.C.S. motor relay	4-4b [T300]
T.C.S. valve relay	4-4b [T300]
Throttle position sensor	2-7 [T2A2]
Test mode connector	2-7 [T2A1]
Transmission control module	2-7 [T2B1]
Turn & hazard module	⑱
Vehicle speed sensor 1	2-7 [T2B1]
Vehicle speed sensor 2	2-7 [T2B1]

1. ENGINE ROOM

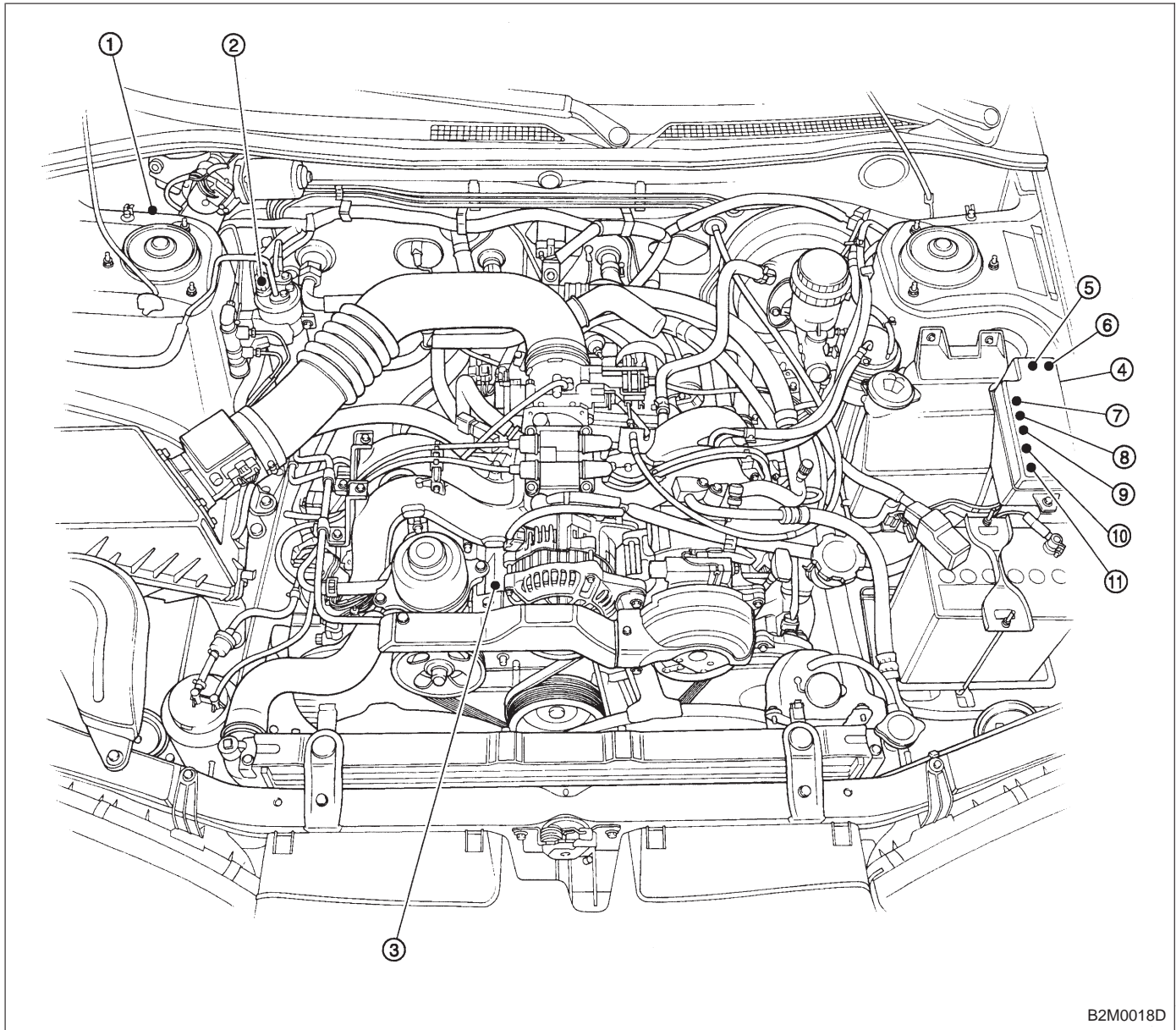

B2M0018D

- ① FWD switch (AT)
- ② A/C pressure switch
- ③ Oil pressure switch
- ④ M/B
- ⑤ Headlight relay LH
- ⑥ Headlight relay RH

- ⑦ A/C compressor relay
- ⑧ A/C main fan relay 2
- ⑨ A/C sub fan relay 2
- ⑩ A/C main fan relay 1
- ⑪ A/C fuse



## 2. INSTRUMENT PANEL

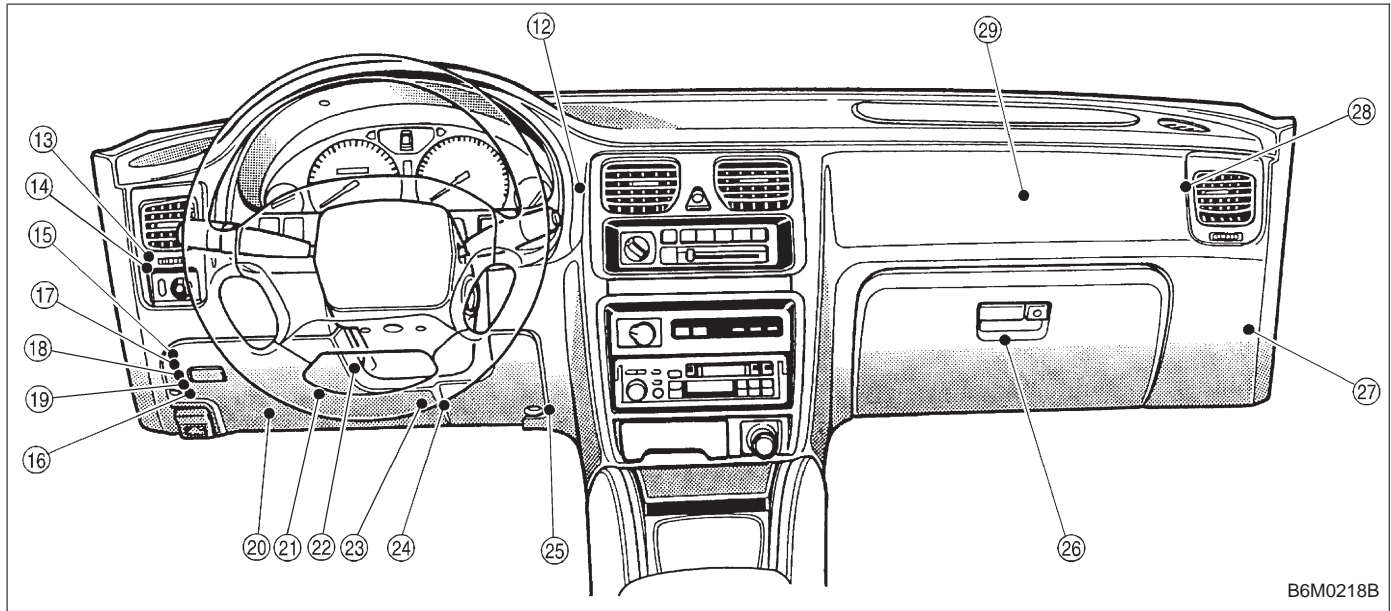

B6M0218B

- |                             |                                |
|-----------------------------|--------------------------------|
| ⑫ Mode actuator             | ⑳ Illumination control module  |
| ⑬ Blower relay              | ㉑ Shift lock control module    |
| ⑭ Horn relay                | ㉒ Power window circuit breaker |
| ⑮ F/B                       | ㉓ Power window & sunroof relay |
| ⑯ Turn & hazard module      | ㉔ Check connector              |
| ⑰ Rear defogger relay       | ㉕ Blower motor resistor        |
| ⑱ Tail & illumination relay | ㉖ Door lock timer              |
| ⑲ Main fan relay            | ㉗ FRESH/RECIRC actuator        |
| ⑳ Seat belt timer           | ㉘ Evaporator thermostwitch     |



### 3. COMPARTMENT

#### ● SEDAN

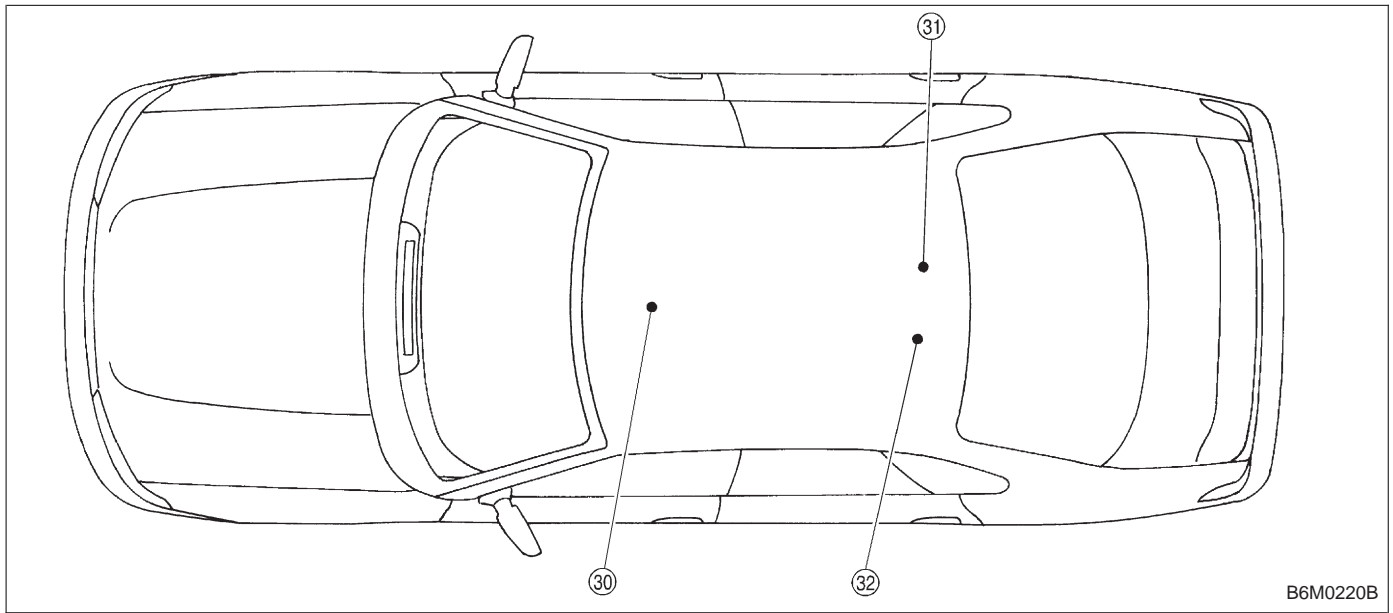

#### ● WAGON

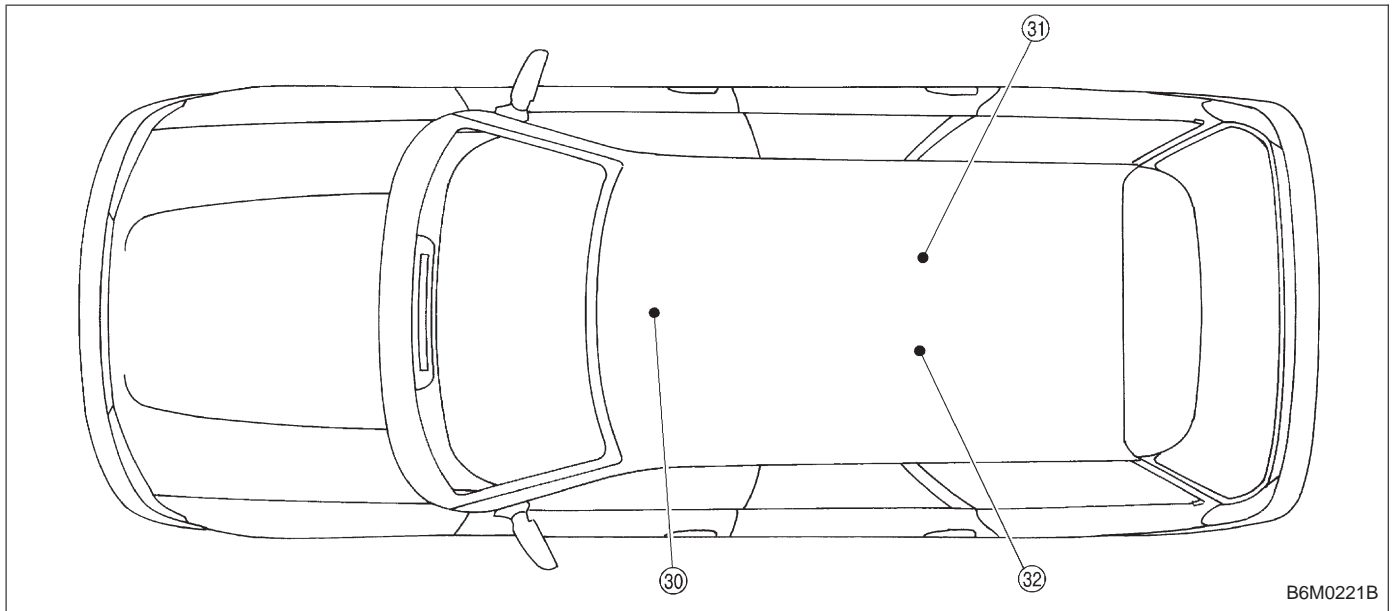

- ③① Sunroof control module
- ③① Fuel gauge module

- ③② Fuel gauge sub module (AWD)

7. Electrical Unit Location

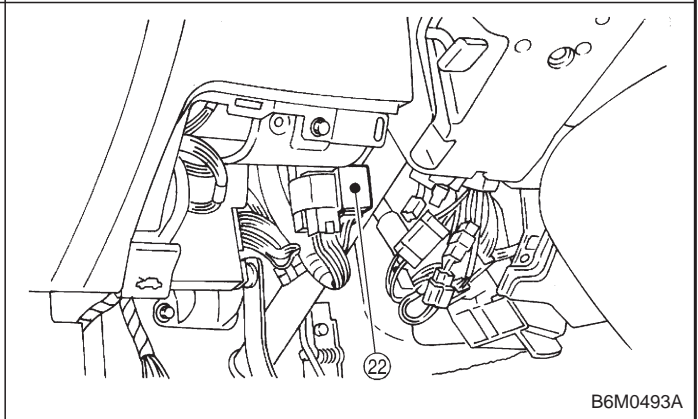
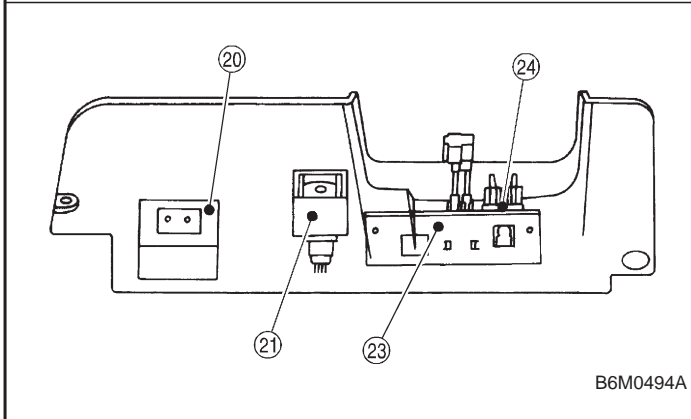
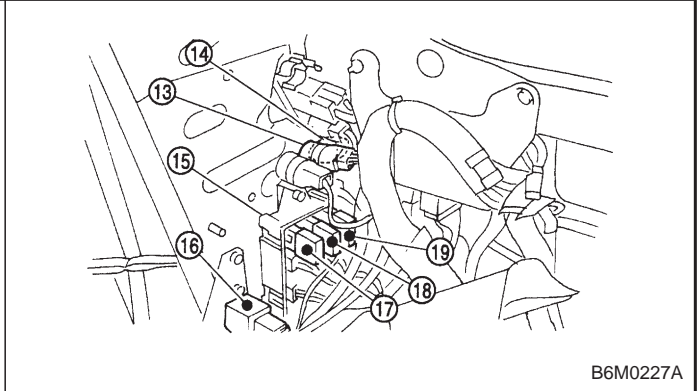
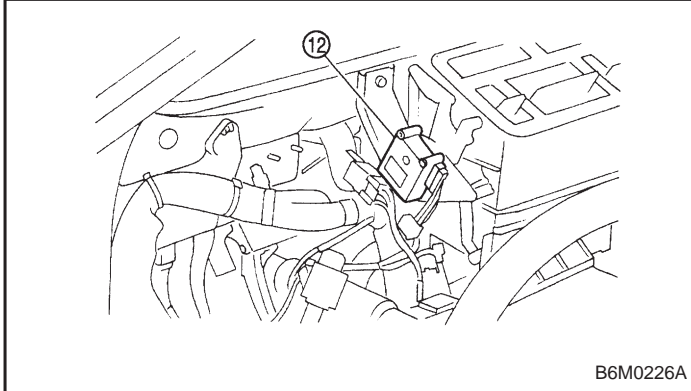
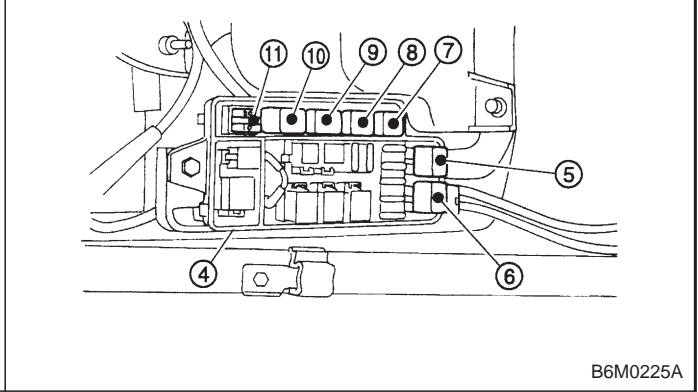
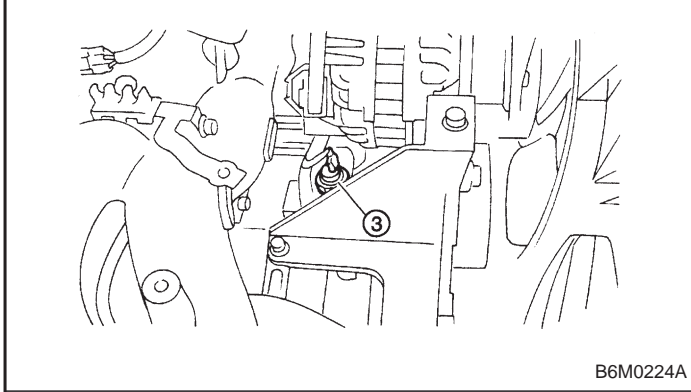
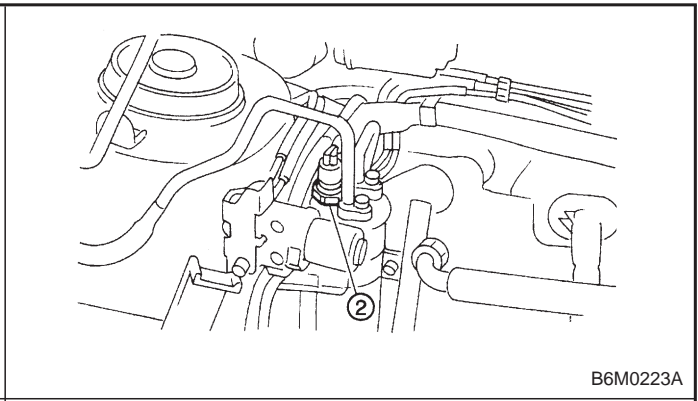
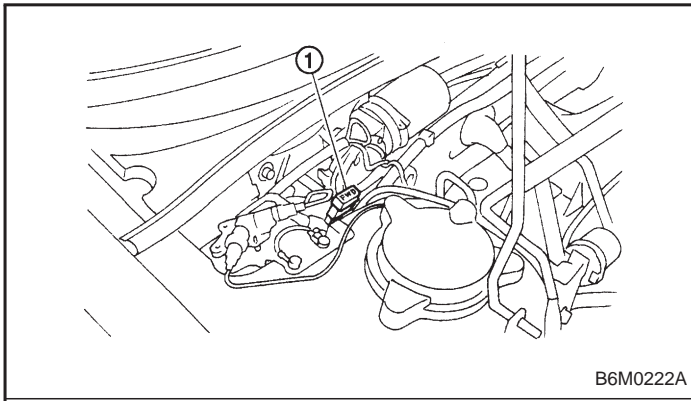

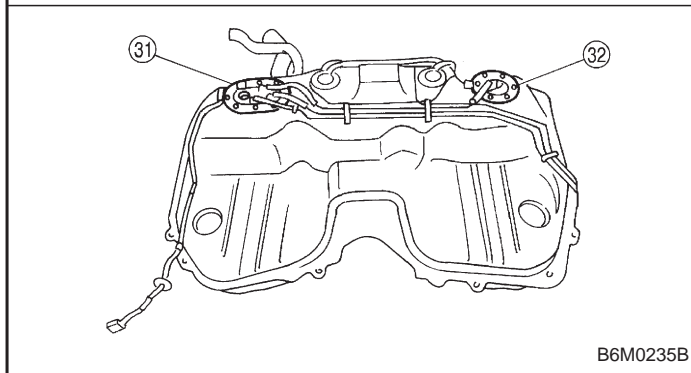
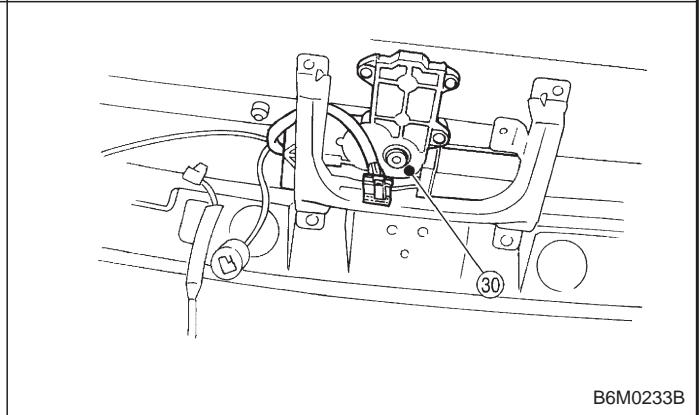
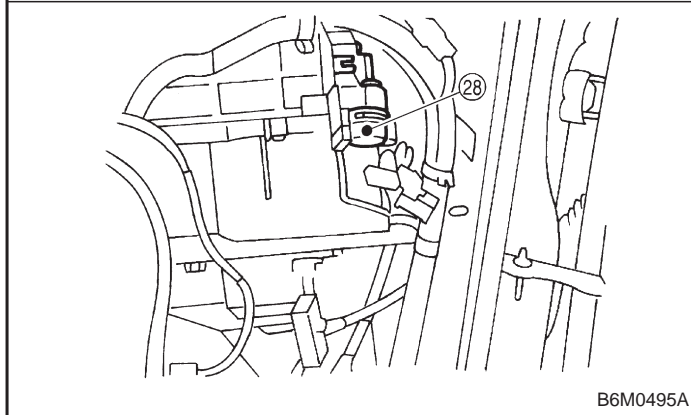
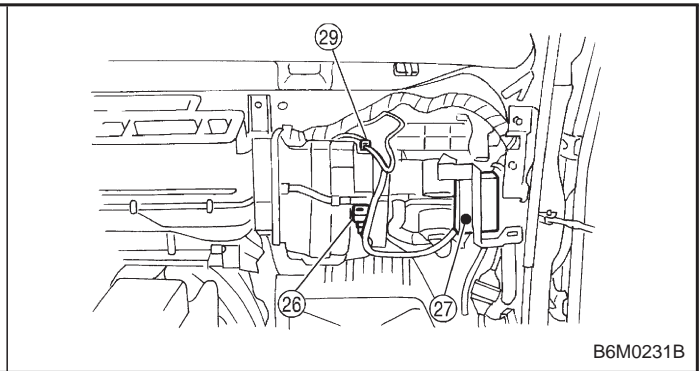
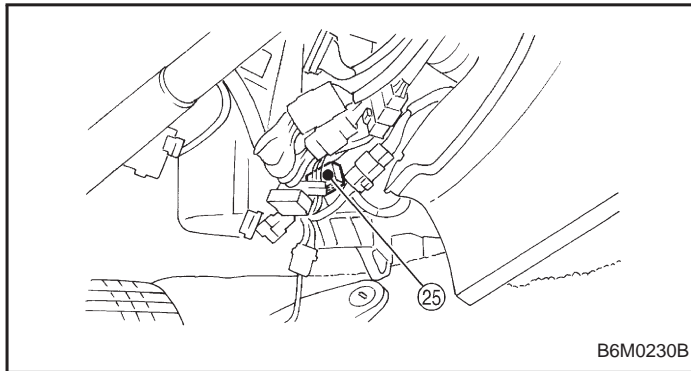

## 8. Electrical Wiring Harness and Ground Point

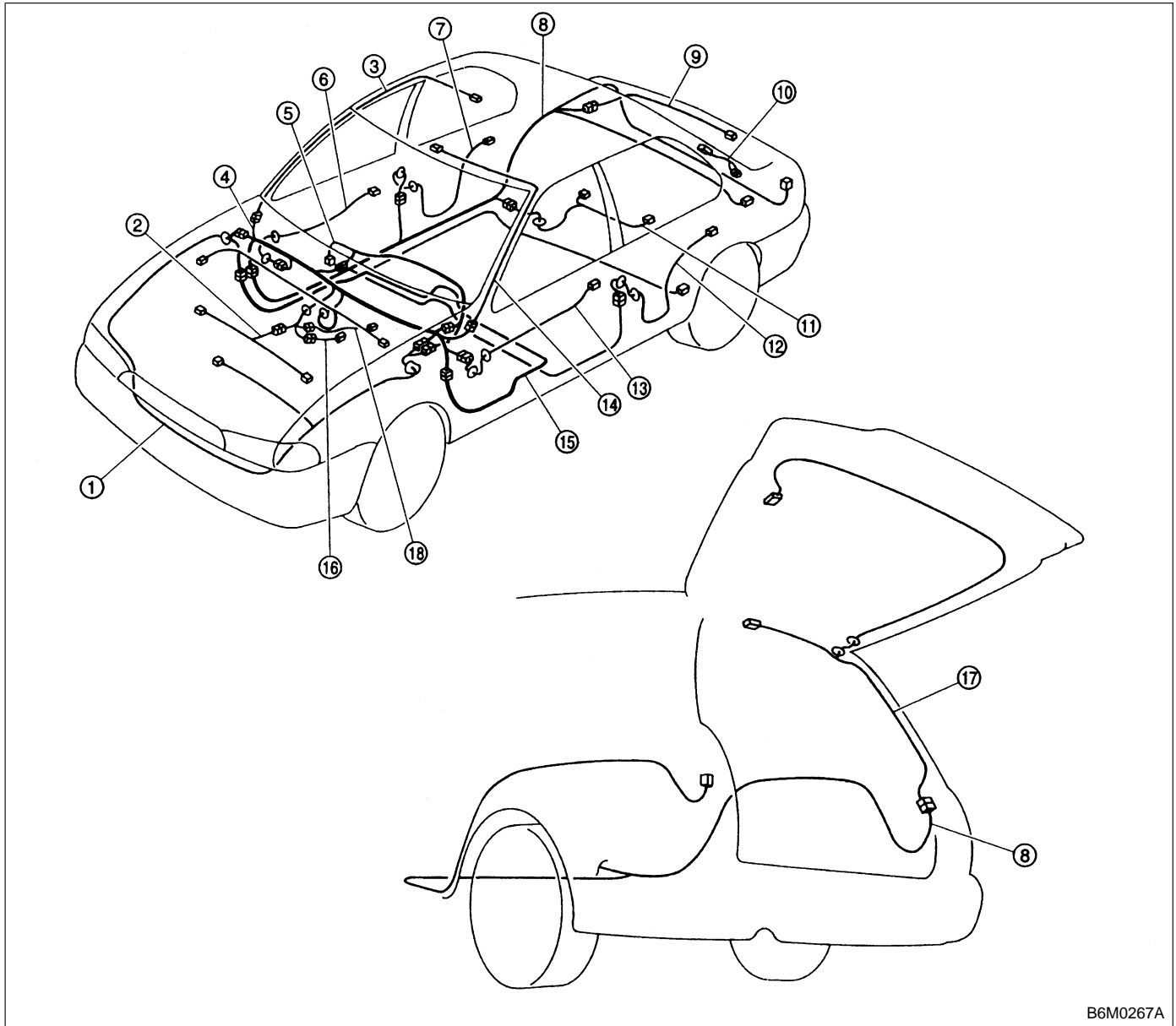

B6M0267A

- |                                   |                                     |
|-----------------------------------|-------------------------------------|
| ① Front wiring harness            | ⑩ Rear defogger ground cord (Sedan) |
| ② Engine wiring harness           | ⑪ Fuel tank cord                    |
| ③ Room light cord                 | ⑫ Rear door cord LH                 |
| ④ Bulkhead wiring harness         | ⑬ Front door cord LH                |
| ⑤ Instrument panel wiring harness | ⑭ Sunroof cord                      |
| ⑥ Front door cord RH              | ⑮ Floor wiring harness              |
| ⑦ Rear door cord RH               | ⑯ Transmission cord                 |
| ⑧ Rear wiring harness             | ⑰ Rear gate cord (Wagon)            |
| ⑨ Trunk lid cord (Sedan)          | ⑱ Rear oxygen sensor cord           |

### 1. FRONT WIRING HARNESS AND GROUND POINT

● LHD model

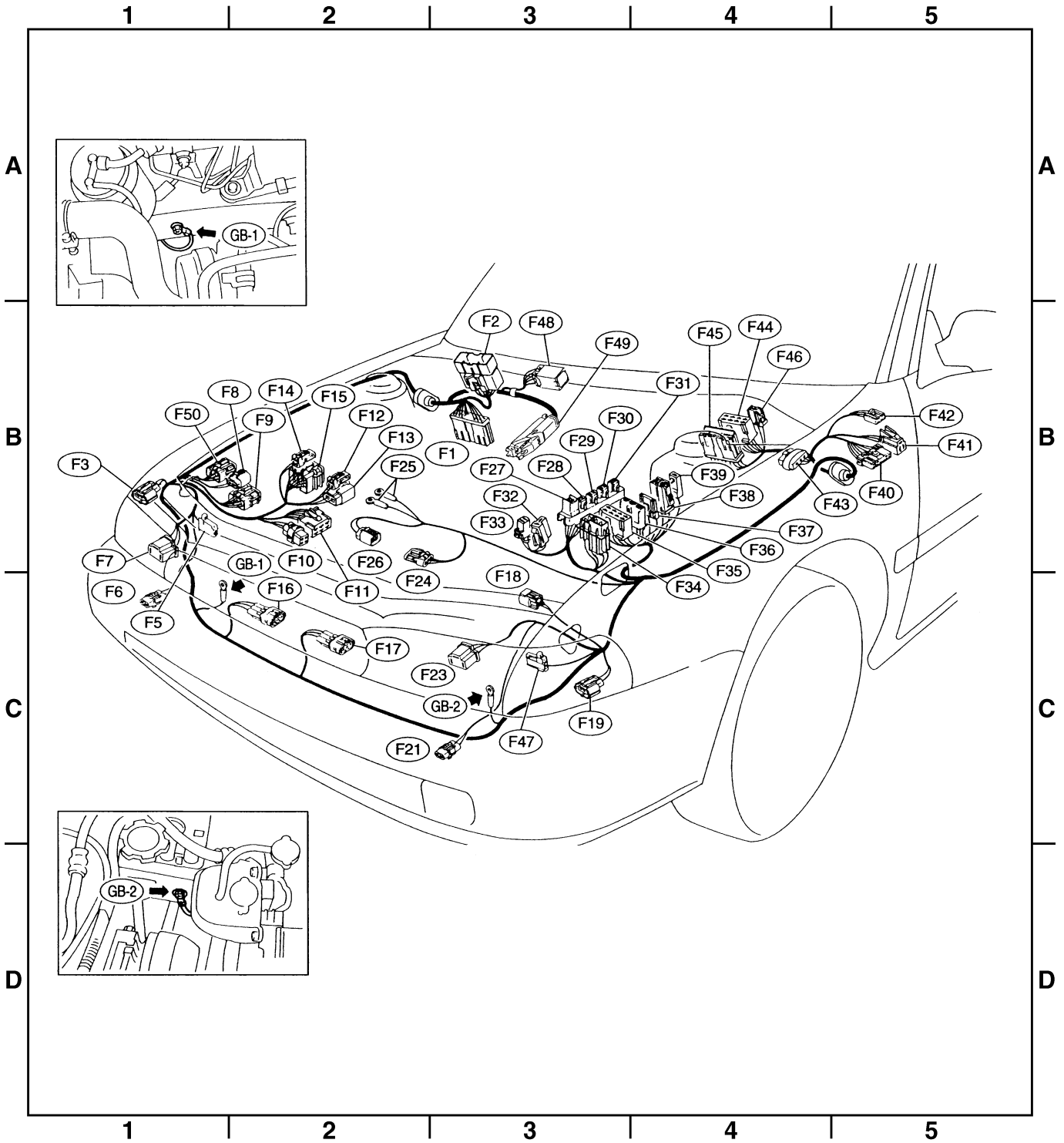

B6M0678

## 8. Electrical Wiring Harness and Ground Point

Connector				Connecting to	
No.	Pole	Color	Area	No.	Name
F1	20	Blue	B-2	P1	Floor wiring harness (With TCS model)
	12	*	B-2	P1	Floor wiring harness (With ABS model)
F2	20	Blue	B-2	B100	Bulkhead wiring harness (With ABS model)
F3	3	Brown	B-1		Front turn signal and side marker light RH
F5	1	Black	B-1		Horn
F6	2	*	C-1		Front fog light RH
	2	Brown	C-1		Front fog light RH (Outback with step roof)
F7	3	Black	B-1		Headlight RH
F8	2	Gray	B-1		Hydraulic unit (ABS)
F9	8	Gray	B-1		
F10	4	*	B-2		TCS motor relay
F11	6	*	B-2		TCS valve relay
F12	2	Black	B-2		TCS pressure switch
F13	2	Black	B-2		TCS motor
F14	2	Gray	B-2		Hydraulic unit (TCS)
F15	12	Gray	B-2		
F16	3	Black	C-1		Sub fan motor
F17	3	Black	C-2		Radiator main fan motor
F18	2	Gray	C-3		Front hood switch (Security)
F19	3	Brown	C-3		Front turn signal and side marker light LH
F21	2	*	C-2		Front fog light LH
	2	Brown	C-2		Front fog light LH (Outback with step roof)
F23	3	Black	C-2		Headlight LH
F24	3	Gray	B-2		A/C compressor
F25	1 x 2	*	B-2		Generator
F26	2	Gray	B-2		
F27	4	Black	B-3		A/C fuse (Relay holder)
F28	4	Black	B-3		A/C main fan relay-1 (Relay holder)
F29	4	Black	B-3		A/C sub fan relay-2 (Relay holder)
F30	4	Black	B-3		A/C main fan relay-2 (Relay holder)
F31	4	Black	B-3		A/C relay (Relay holder)
F32	2	Green	B-2		Front washer motor
F33	2	*	B-3		Rear washer motor
F34	4	Black	B-3		M/B
F35	8	Black	B-3		
F36	3	*	B-3		
F37	2	Black	B-3		
F38	2	Black	B-3		
F39	1	Brown	B-3		
F40	10	Gray	B-4		
F41	3	Gray	B-4		F/B
F42	5	Gray	B-4		
F43	3	Orange	B-4		A/C diode
F44	8	*	B-3	B61	Bulkhead wiring harness
F45	20	*	B-3	B62	
F46	2	Black	B-4	B108	Bulkhead wiring harness (Outback)
F47	1	Black	C-3		Horn (TAIWAN model)
F48	6	*	B-3		Shield joint connector (ABS)
F49	83	Black	B-3		ABS control module
F50	6	Black	B-1		ABS relay box

\*: Non-colored

### 1. FRONT WIRING HARNESS AND GROUND POINT

- RHD model

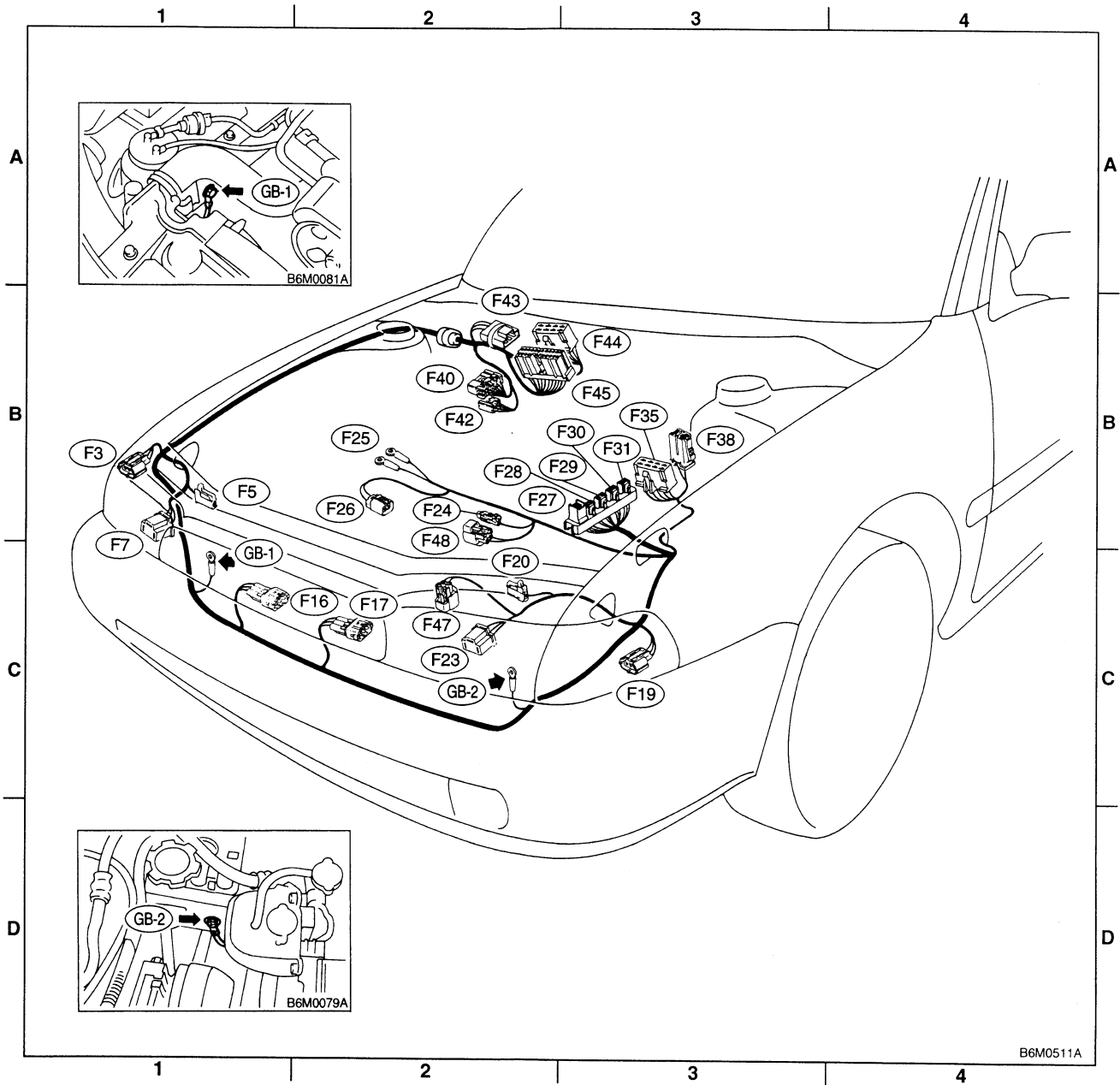

Connector				Connecting to	
No.	Pole	Color	Area	No.	Name
F3	3	Brown	B-1		Front turn signal and side marker light RH
F5	1	Black	B-1		Horn
F7	3	Black	B-1		Headlight RH
F16	3	Black	C-1		Sub fan motor
F17	3	Black	C-2		Radiator main fan motor
F19	3	Brown	C-3		Front turn signal and side marker light LH
F20	1	Black	C-2		Horn
F23	3	Black	C-2		Headlight LH
F24	1	Black	B-2		A/C compressor
F25	1 x 2	*	B-2		Generator
F26	2	Gray	B-2		
F27	4	Black	B-3		A/C fuse (Relay holder)
F28	4	Black	B-3		A/C main fan relay-1 (Relay holder)
F29	4	Black	B-3		A/C sub fan relay-2 (Relay holder)
F30	4	Black	B-3		A/C main fan relay-2 (Relay holder)
F31	4	Black	B-3		A/C relay (Relay holder)
F35	8	Black	B-3		M/B
F38	2	Black	B-3		
F40	10	Gray	B-2		F/B
F42	5	Gray	B-2		
F43	3	Orange	B-2		A/C diode
F44	8	*	B-2	B61	Bulkhead wiring harness
F45	20	*	B-2	B62	
F47	2	Gray	C-2		A/C pressure switch
F48	2	Blue	B-2		Thermal protector

\*: Non-colored



### 2. BULKHEAD WIRING HARNESS AND GROUND POINT (IN ENGINE ROOM)

- LHD model

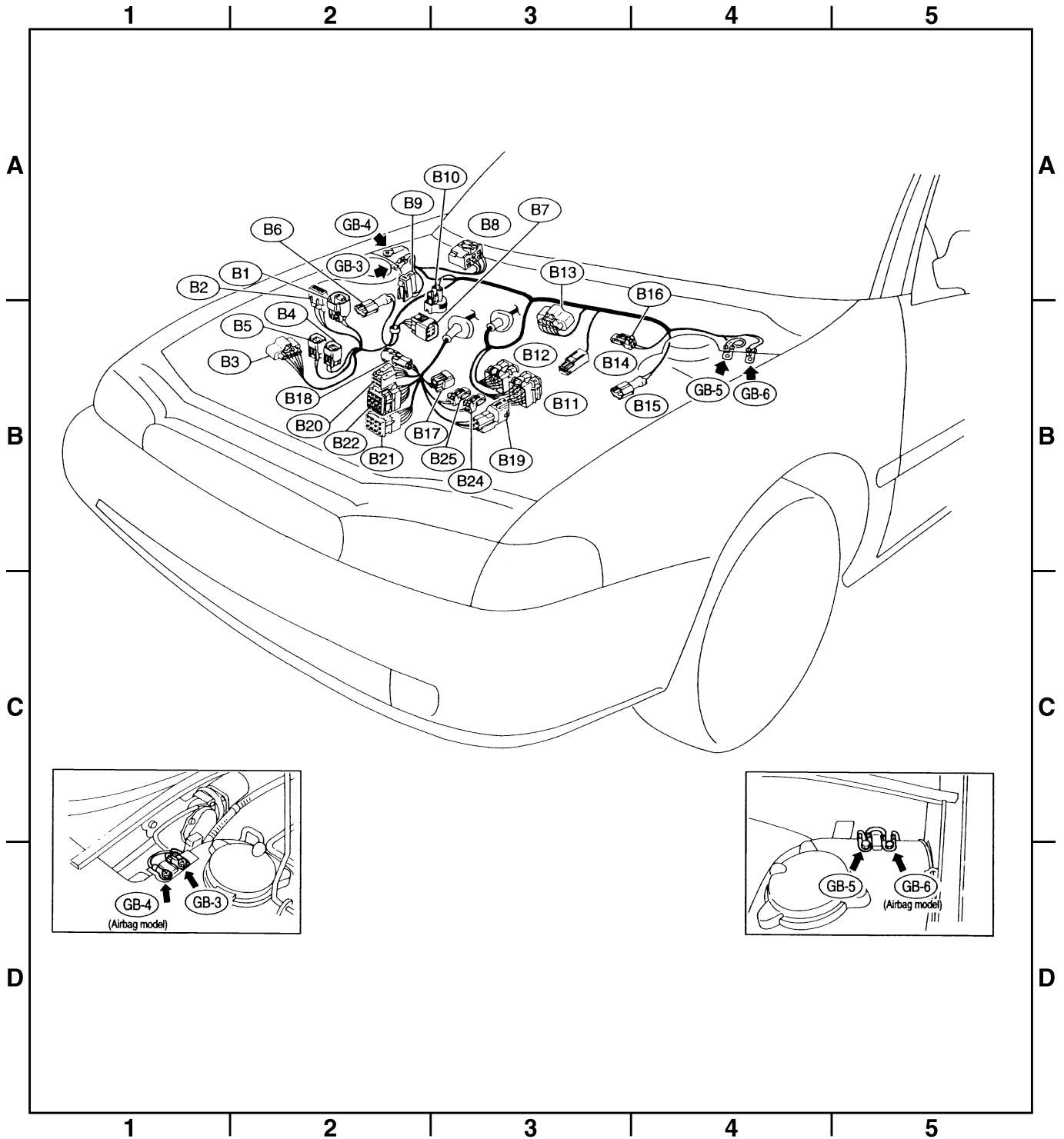

B6M0679

Connector				Connecting to	
No.	Pole	Color	Area	No.	Name
B1	2	*	B-2		Pressure source switching solenoid
B2	3	Black	B-2		Pressure sensor
B3	5	Gray	B-2		Mass air flow sensor
B4	2	Gray	B-2		AT dropping resistor
B5	2	Gray	B-2		Resistor (Daytime running light)
B6	2	Gray	B-2		ABS front sensor RH
	2	Brown	B-2		ABS front sensor RH (Outback with step roof)
B7	4	*	B-2		Cruise control pump
B8	6	*	A-2		Front wiper motor
B9	2	Black	A-2		FWD switch (AT)
B10	2	Brown	B-2		A/C pressure switch
B11	16	Gray	B-3	T4	Transmission (AT)
B12	12	Gray	B-2	T3	
B13	6	Gray	B-3		Ignitor
B14	1	Black	B-3		Starter (Magnet)
B15	2	Gray	B-3		ABS front sensor LH
	2	Brown	B-3		ABS front sensor LH (Outback with step roof)
B16	2	Gray	B-3		Brake fluid level switch
B17	2	Black	B-2		Vehicle speed sensor
B18	3	Dark gray	B-2		Front oxygen sensor
B19	4	*	B-2	T5	Rear oxygen sensor cord (Other models)
	4	*	B-2		Rear oxygen sensor (California model)
B20	6	Light gray	B-2	E1	Engine wiring harness
B21	12	Light gray	B-2	E2	
B22	16	Light gray	B-2	E3	
B24	2	Gray	B-2	T1	Back-up light switch (MT)
B25	2	Brown	B-2	T2	Neutral position switch (MT)

\*: Non-colored

### 2. BULKHEAD WIRING HARNESS AND GROUND POINT (IN ENGINE ROOM)

- RHD model

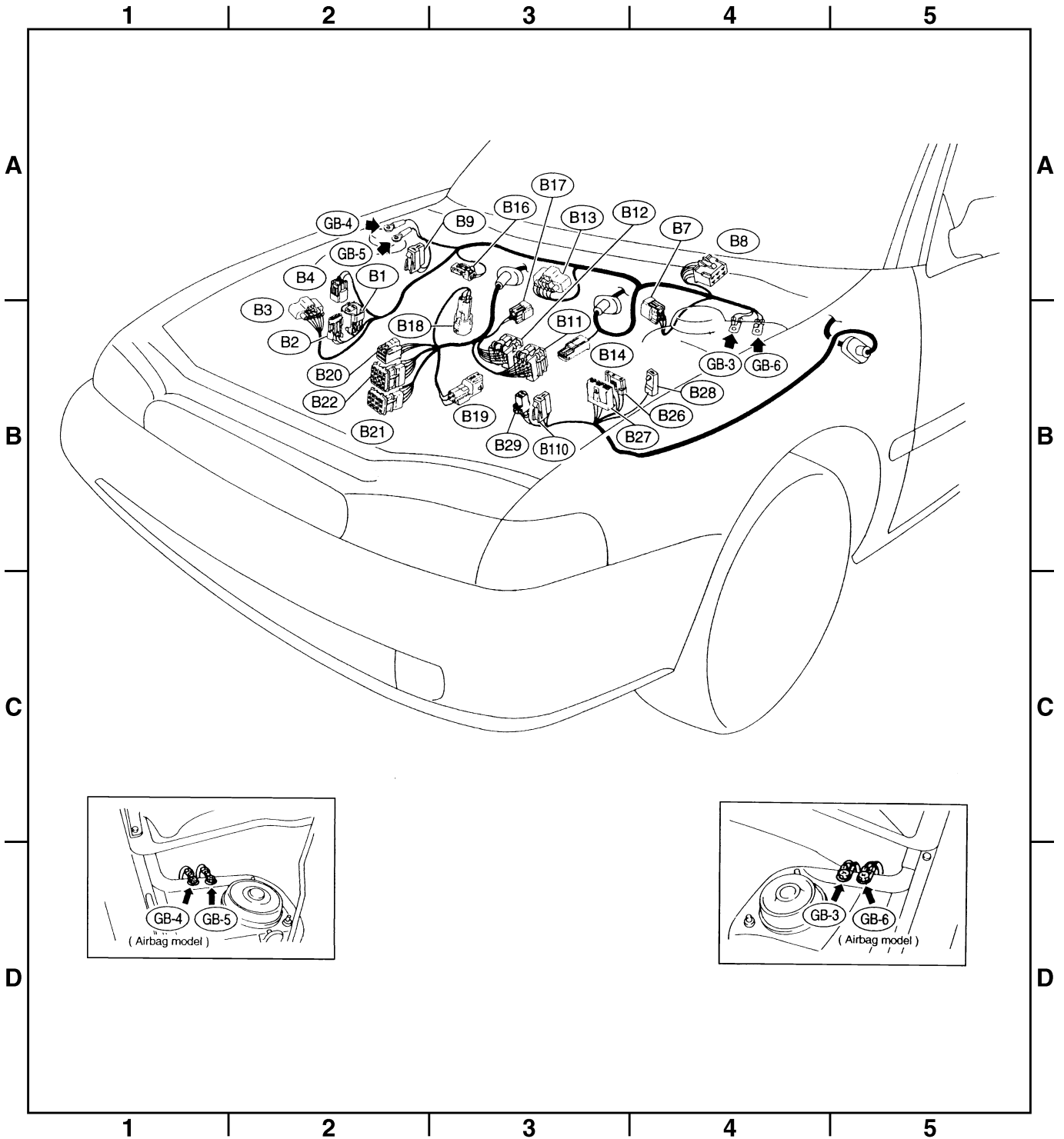

EPA0101

Connector				Connecting to	
No.	Pole	Color	Area	No.	Name
B1	2	Brown	B-2		Pressure sources switching solenoid
B2	3	Black	B-2		Pressure sensor
B3	5	Gray	B-2		Mass air flow sensor
B4	2	Gray	B-2		AT dropping resistor
B7	4	Gray	B-3		Cruise control pump
B8	6	*	B-3		Front wiper motor
B9	2	Black	A-2		FWD switch
B11	16	Gray	B-3	T4	Transmission
B12	12	Gray	B-2	T3	
B13	6	Gray	B-3		Ignitor
B14	1	Black	B-3		Starter (Magnet)
B16	2	Gray	B-2		Brake fluid level switch
B17	2	Black	B-3		Vehicle speed sensor
B18	3	Dark gray	B-2		Front oxygen sensor
B19	4	*	B-2	T5	Rear oxygen sensor cord (Other models)
	4	*	B-2		Rear oxygen sensor (California model)
B20	6	Light gray	B-2	E1	Engine wiring harness
B21	12	Light gray	B-2	E2	
B22	16	Light gray	B-2	E3	
B26	2	Black	B-3		M/B
B27	3	*	B-3		
B28	1	Brown	B-3		
B29	2	*	B-2		Rear washer motor
B110	2	Green	B-3		Front washer motor

\*: Non-colored

3. ENGINE WIRING HARNESS, TRANSMISSION CORD AND GROUND POINT

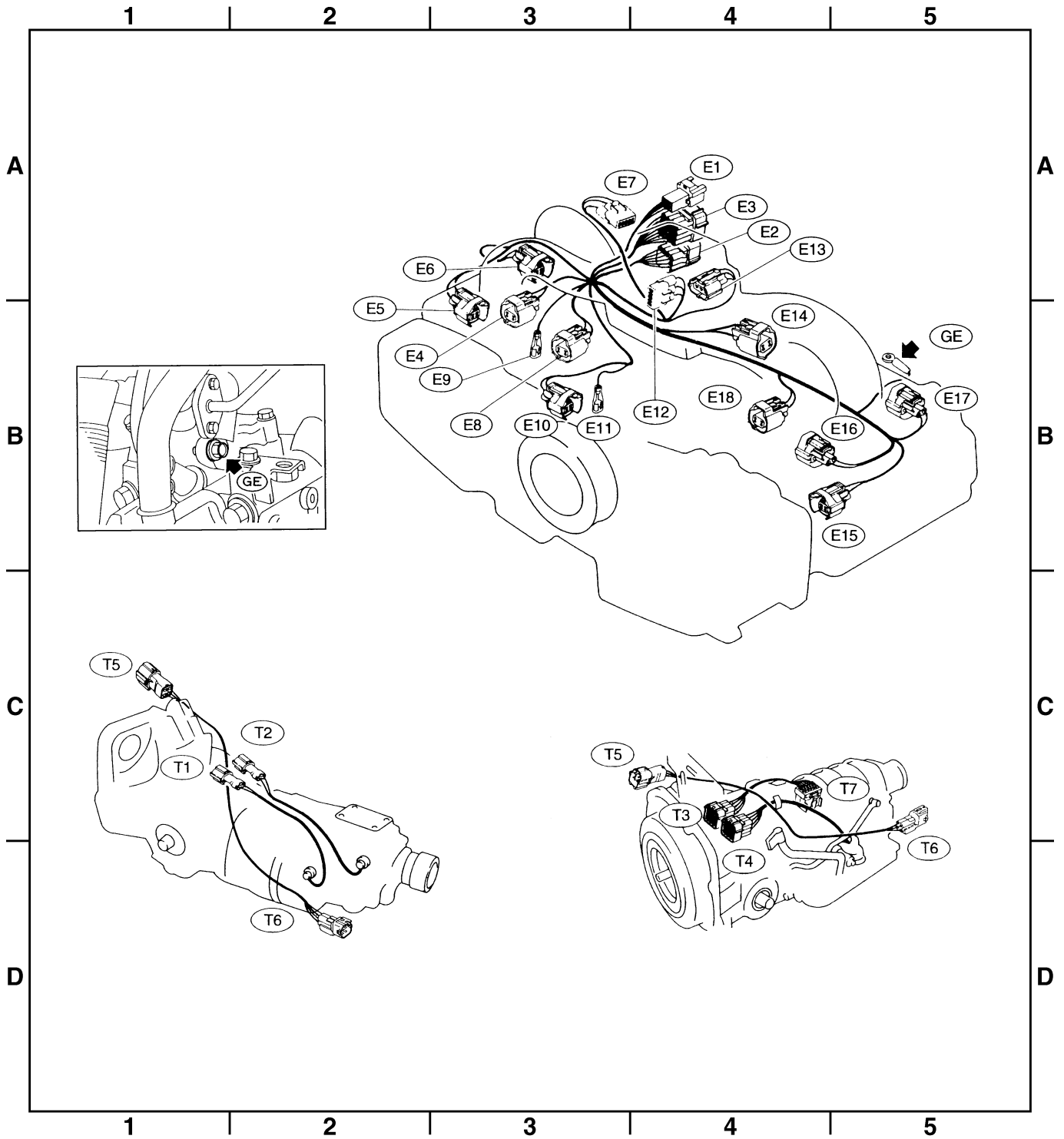

EPA0102

Connector				Connecting to	
No.	Pole	Color	Area	No.	Name
E1	6	*	A-3	B20	Bulkhead wiring harness
E2	12	Gray	A-3	B21	
E3	16	Gray	A-3	B22	
E4	2	Blue	A-2		Purge control solenoid valve
E5	2	Light gray	A-2		Injector #1
E6	2	Dark gray	A-3		Injector #3
E7	3	Gray	A-3		Idle air control solenoid valve
E8	2	Brown	B-3		Engine coolant temperature sensor
E9	1	*	B-3		Thermometer
E10	2	Gray	B-3		Crankshaft position sensor
E11	1	*	B-3		Oil pressure switch
E12	3	Gray	A-3		Ignition coil
E13	3	Brown	A-3		Throttle position sensor
E14	2	Gray	B-3		Knock sensor
E15	2	Dark gray	B-4		Camshaft position sensor
E16	2	Light gray	B-4		Injector #2
E17	2	Dark gray	B-4		Injector #4
E18	2	Brown	B-3		EGR solenoid (AT)

\*: Non-colored

Connector				Connecting to	
No.	Pole	Color	Area	No.	Name
T1	2	Gray	C-1	B24	Bulkhead wiring harness (MT)
T2	2	Brown	C-1	B25	
T3	12	Gray	D-3	B12	Bulkhead wiring harness (AT)
T4	16	Gray	D-3	B11	
T5	4	Gray	C-1/C-3	B19	Bulkhead wiring harness
T6	4	Gray	D-2/D-4		Rear oxygen sensor
T7	12	*	C-4		Inhibitor switch (AT)

\*: Non-colored

4. BULKHEAD WIRING HARNESS (IN COMPARTMENT)

● LHD model

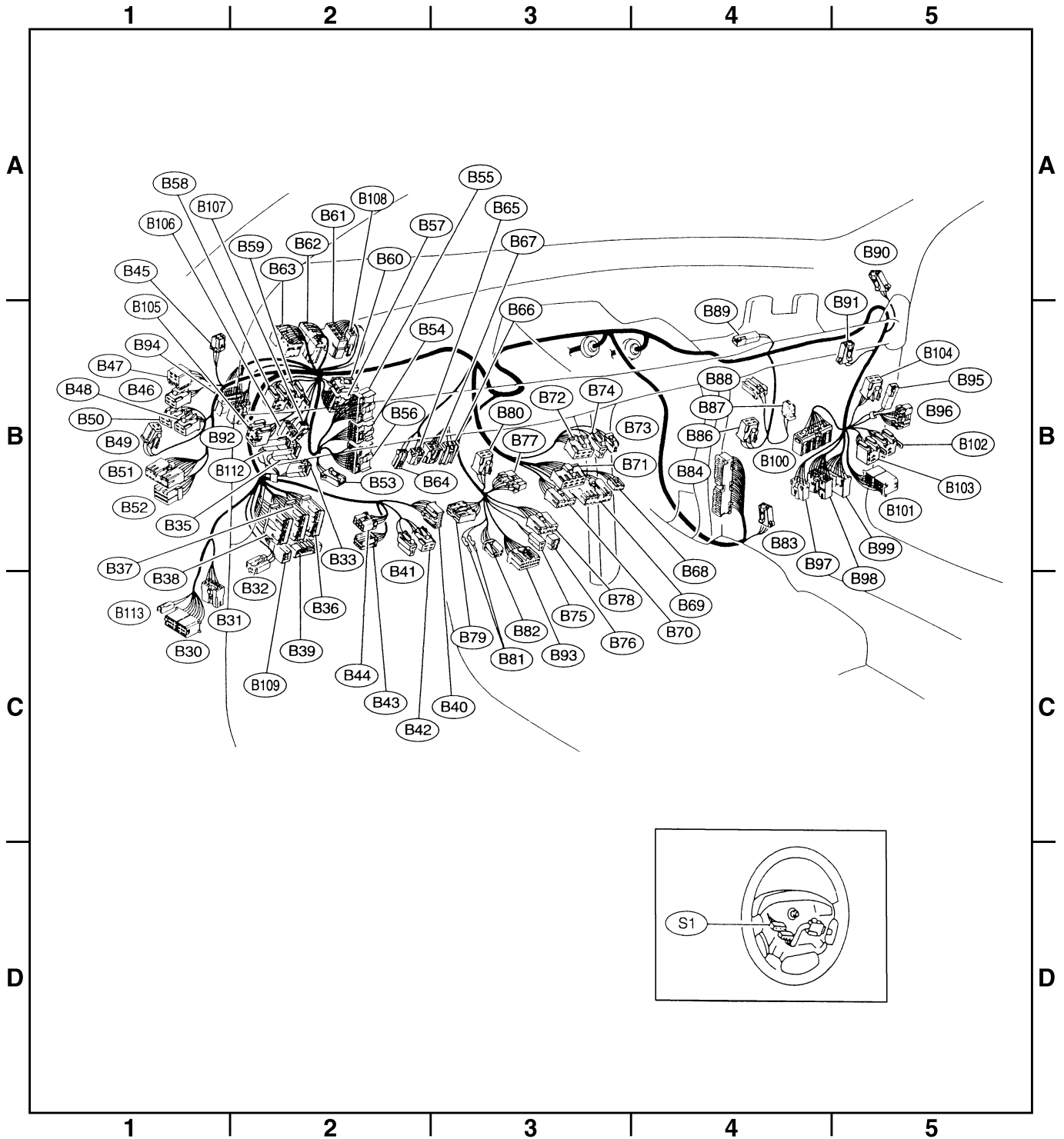

B6M0765

## 8. Electrical Wiring Harness and Ground Point

Connector				Connecting to	
No.	Pole	Color	Area	No.	Name
B30	24	*	C-1	D1	Front door cord LH
B31	7	Yellow	C-1	AB1	SRS (Airbag) harness
B32	3	Black	C-1		Turn & hazard module
B33	4	Brown	B-1		Diode (Brake fluid level)
B35	2	Black	B-1		Diode (Without step light)
	4	Brown	B-1		Diode (With step light)
B36	22	Black	C-1	i1	Instrument panel wiring harness
B37	22	*	C-1	i2	
B38	22	Brown	C-1	i3	
B39	20	Blue	C-1	i4	
B40	16	Gray	C-2		OB-D-II service connector
B41	2	*	C-2		Power window circuit breaker
B42	4	*	C-2		Power window and sunroof relay
B43	6	Black	C-2		Illumination control module
B44	8	*	C-2		Seat belt timer
B45	4	*	B-1	R53	Sunroof cord
B46	4	Green	B-1		Fuel pump relay
B47	6	Brown	B-1		Main relay
B48	4	Blue	B-1		Front fog light relay
B49	3	Black	B-1		Horn relay
B50	4	*	B-1		Blower relay
B51	11	Gray	B-1		F/B
B52	12	Gray	B-1		
B53	4	*	B-2		Shield joint connector (AT)
B54	12	Black	B-2		Transmission control module
B55	16	Black	B-2		
B56	20	Black	B-2		
B57	12	Black	B-2		Shift-lock control module
B58	5	Black	B-1		Headlight alarm relay (Security)
B59	5	Black	B-1		Interrupt relay (Security)
B60	4	*	B-2		Shield joint connector (With TCS model)
B61	8	*	B-2	F44	Front wiring harness
B62	20	*	B-1	F45	
B63	40	Gray	B-1	P10	Floor harness (With TCS model)
B64	2	Black	B-2		Stop light switch
B65	4	Black	B-2		Stop & brake switch (With cruise control)
B66	3	Black	B-2		Pedal stroke sensor (TCS)
B67	4	Black	B-2		Pedal stroke switch (TCS)
B68	5	Black	B-3		Slip ring
B69	11	Black	B-3		Combination switch
B70	9	*	B-3		
B71	8	*	B-3		
B72	6	Black	B-3		Ignition switch
B73	2	Black	B-3		Key lock solenoid (AT)
B74	2	Black	B-3		Key warning switch

Connector				Connecting to	
No.	Pole	Color	Area	No.	Name
B75	2	Green	C-2	B76	Test mode connector
B76	2	Green	C-3	B75	
B77	10	Brown	B-2		Mode actuator
B78	9	Yellow	C-2		Data link connector
B79	14	Gray	C-2		Check connector
B80	4	Blue	B-2	i20	Instrument panel wiring harness
B81	1 x 2	*	C-2		Diagnosis terminal (Ground)
B82	6	Black	C-2		Diagnosis connector
B83	4	*	C-3		Shield joint connector (E/G)
B84	96	Light blue	B-3		Engine control module
B86	4	*	B-3		Blower motor resistor
B87	2	*	B-3		Blower motor
B88	3	Black	B-3		Evaporator thermostatswitch
B89	2	Black	B-3		Diode (Security)
B90	4	*	B-4	R50	Room light cord
B91	4	*	B-4		FRESH/RECIRC actuator
B92	8	*	B-4		Door lock timer
B93	16	Black	B-4		Security control module
B94	20	Black	B-4		Cruise control module
B95	2	Black	B-4		Diode (Daytime running light)
B96	10	*	B-4		Daytime running light control module
B97	8	*	B-4	R1	Rear wiring harness
B98	20	*	B-4	R2	Rear wiring harness (Other models)
	24	Black	B-4	R2	Rear wiring harness (2200 cc engine AWD except Taiwan model)
B99	24	*	B-4	R3	Rear wiring harness
B100	20	Blue	B-4	F2	Front wiring harness (With ABS model)
B101	24	*	B-4	D11	Front door cord RH
B102	5	Black	B-4		Daytime running light relay
B103	4	Blue	B-4		High-beam relay (Daytime running light)
B104	4	Pink	B-4		Rear power supply relay
B105	4	Blue	B-1		Starter interlock relay (MT)
B106	2	*	B-1		Clutch switch (MT)
B107	2	Blue	B-1		Clutch switch (Cruise control)
B108	2	Black	B-2	F46	Front wiring harness (Outback)
B109	4	Black	C-1		Fuse holder (Outback)
B112	2	Black	B-1		Diode (Front fog light)
B113	2	*	C-1	D50	Front door cord LH

\*: Non-colored

Connector				Connecting to	
No.	Pole	Color	Area	No.	Name
S1	3	White	D-3		Cruise control sub switch



4. BULKHEAD WIRING HARNESS (IN COMPARTMENT)

● RHD model

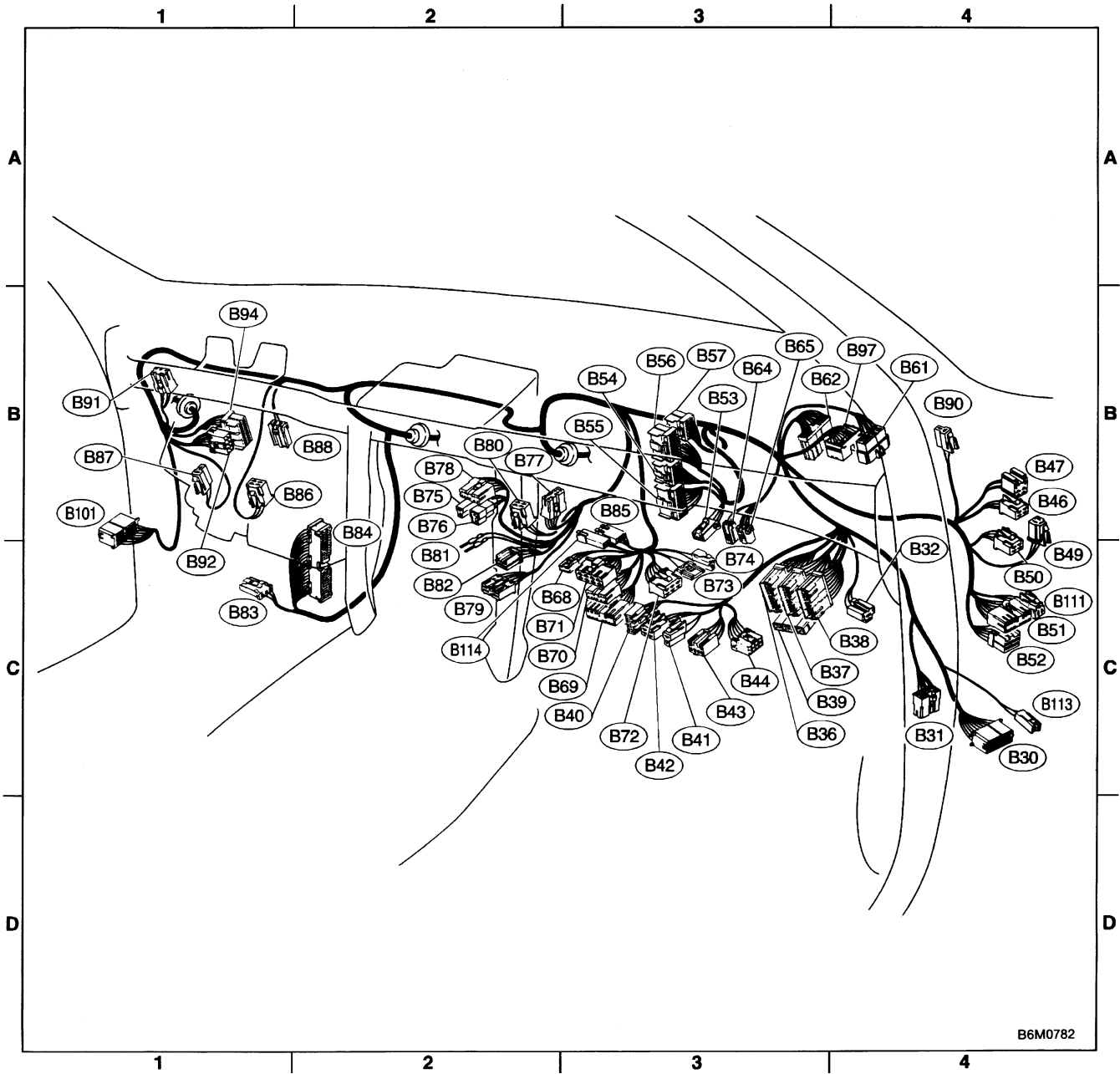

## 8. Electrical Wiring Harness and Ground Point

Connector				Connecting to	
No.	Pole	Color	Area	No.	Name
B30	24	*	C-4	D1	Front door cord RH
B31	7	Yellow	C-4	AB1	SRS (Airbag) harness
B32	3	Black	C-4		Turn & hazard module
B36	22	Black	C-3	i1	Instrument panel wiring harness
B37	22	*	C-3	i2	
B38	22	Brown	C-3	i3	
B39	20	Blue	C-3	i4	
B40	16	Gray	C-3		OBD-II service connector
B41	2	*	C-3		Power window circuit breaker
B42	4	*	C-3		Power window relay
B43	6	Black	C-3		Illumination control module
B44	8	*	C-3		Seat belt timer
B46	4	Green	B-4		Fuel pump relay
B47	6	Brown	B-4		Main relay
B49	3	Black	B-4		Horn relay
B50	4	*	B-4		Blower relay
B51	11	Gray	C-4		F/B
B52	12	Gray	C-4		
B53	4	*	B-3		Shield joint connector (AT)
B54	12	Black	B-3		Transmission control module
B55	16	Black	B-3		
B56	20	Black	B-3		
B57	12	Black	B-3		Shift-lock control module
B61	8	*	B-4	F44	Front wiring harness
B62	20	*	B-4	F45	
B64	2	Black	B-3		Stop light switch
B65	4	Black	B-3		Stop & brake switch (With cruise control)
B68	5	Black	B-3		Cruise control sub switch

Connector				Connecting to	
No.	Pole	Color	Area	No.	Name
B69	11	Black	C-3		Combination switch
B70	9	*	C-3		
B71	8	*	B-3		
B72	6	Black	C-3		Ignition switch
B73	2	Black	B-3		Key lock solenoid
B74	2	Black	B-3		Key warning switch
B75	2	Green	B-2	B76	Test mode connector
B76	2	Green	B-2	B75	
B77	7	*	B-2		Mode actuator
B78	9	Yellow	B-2		Data link connector
B79	14	Gray	C-2		Check connector
B80	4	Blue	B-2	i20	Instrument panel wiring harness
B81	1 x 2	*	B-2		Diagnosis terminal (Ground)
B82	6	Black	B-2		Diagnosis connector
B83	4	*	C-1		Shield joint connector (E/G)
B84	96	Light blue	C-2		Engine control module
B85	4	Brown	B-3		Diode (Lighting)
B86	4	Black	B-1		Blower motor resistor
B87	2	Black	B-1		Blower motor
B88	3	Black	B-1		Evaporator thermostic switch
B90	2	Green	B-4	R50	Room light cord
B91	5	*	B-1		FRESH/RECIRC actuator
B92	8	*	B-1		Door lock timer
B94	20	Black	B-1		Cruise control module
B97	56	*	B-4	R1	Rear wiring harness (S.M.J.)
B101	24	*	B-1	D11	Front door cord LH
B111	3	Gray	C-4		F/B
B113	2	*	C-4	D50	Front door cord RH
B114	2	Black	C-3		Diode (Door warning)

\*: Non-colored

### 5. INSTRUMENT PANEL WIRING HARNESS AND GROUND POINT

● LHD model

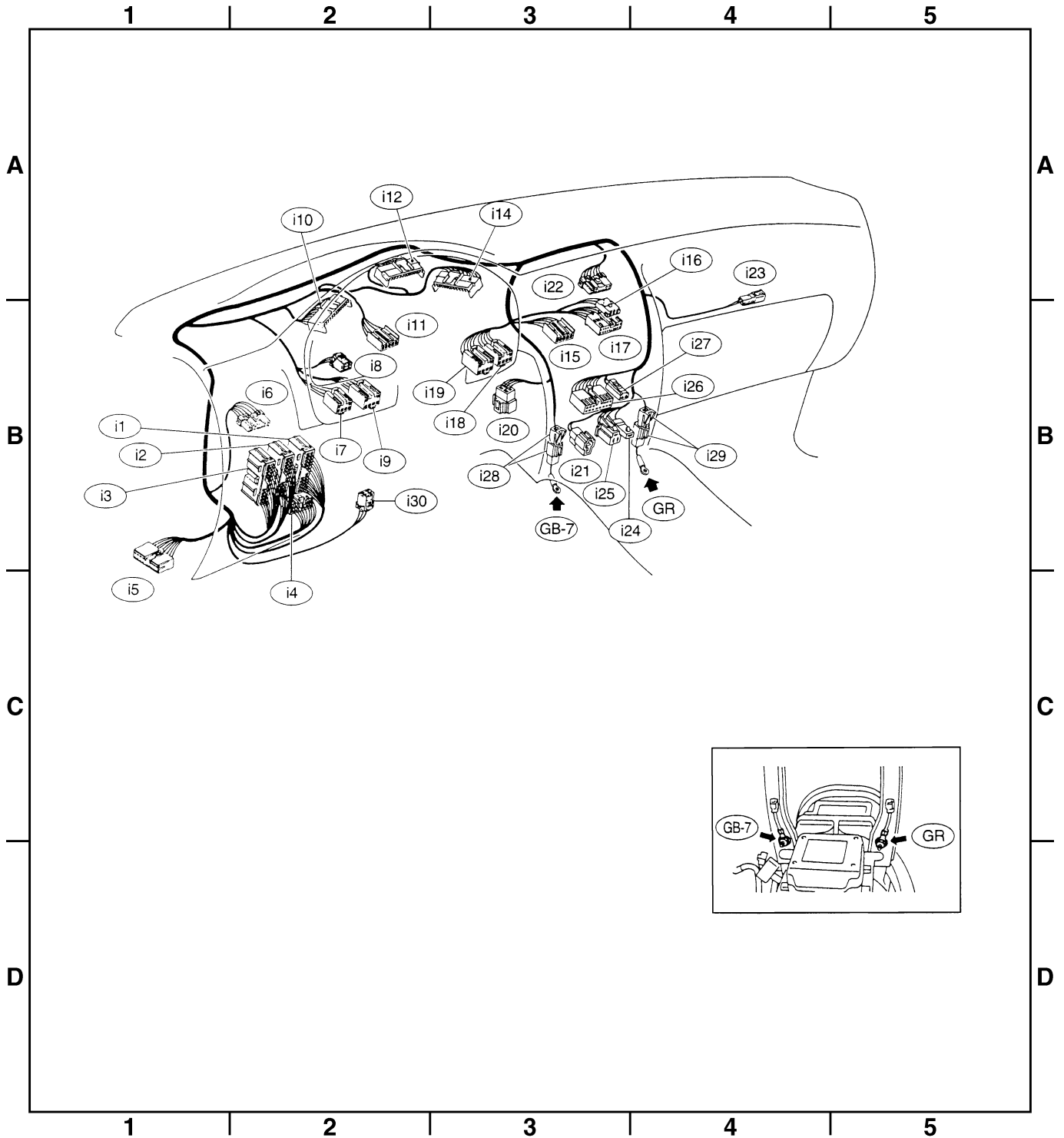

EPA0103

Connector				Connecting to	
No.	Pole	Color	Area	No.	Name
i1	22	Black	C-2	B36	Bulkhead wiring harness
i2	22	*	C-1	B37	
i3	22	Brown	C-1	B38	
i4	20	Blue	C-2	B39	
i5	15	Gray	C-1		F/B
i6	10	*	C-1		Remote control rearview mirror switch
i7	6	Yellow	B-2		Front fog light switch
i8	4	Brown	B-2		Security indicator light
i9	6	*	B-2		TCS off switch
i10	16	Light gray	B-2		Combination meter
i11	5	Light blue	B-2		
i12	16	Light gray	B-2		Combination meter
i14	13	*	B-2		Combination meter
i15	6	*	B-3		Fan switch
i16	3	*	B-3		A/C switch
i17	16	*	B-3		Mode control panel
i18	6	*	B-3		Rear defogger switch
i19	6	Brown	B-2		Cruise control main switch
i20	4	Blue	B-3	B80	Bulkhead wiring harness
i21	2	Black	C-3		Ash tray illumination light
i22	10	*	B-3		Hazard switch
i23	2	Brown	B-4		Glove box illumination light
i24	1	*	C-3		Front accessory power supply
i25	3	*	C-3		
i26	14	*	B-3		Radio
i27	2	*	B-3		CD player illumination light
i28	1	Black	C-3		Ground
i29	1	Black	C-3		Ground (Radio)
i30	4	*	B-2		Rear window defogger timer

\*: Non-colored

### 5. INSTRUMENT PANEL WIRING HARNESS AND GROUND POINT

- RHD model

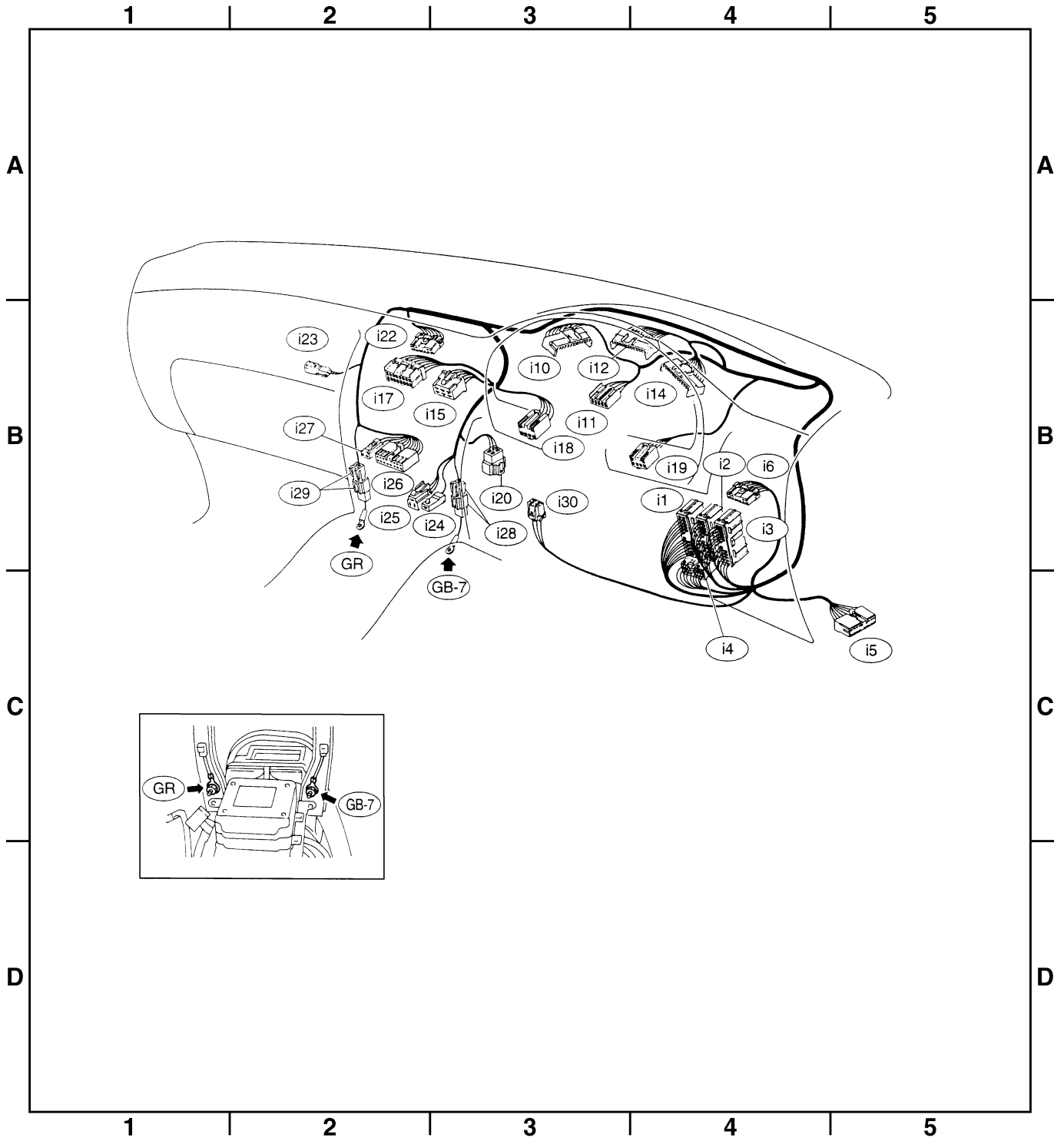

EPA0104

Connector				Connecting to	
No.	Pole	Color	Area	No.	Name
i1	22	Black	C-4	B36	Bulkhead wiring harness
i2	22	*	C-4	B37	
i3	22	Brown	C-4	B38	
i4	20	Blue	C-4	B39	
i5	15	Gray	C-4		F/B
i6	10	*	C-4		Remote control rearview mirror switch
i10	16	Light gray	B-3		Combination meter
i11	5	Light blue	B-3		
i12	16	Light gray	B-3		Combination meter
i14	13	*	B-3		Combination meter
i15	6	*	B-2		Fan switch
i17	16	Black	B-2		Mode control panel
i18	6	*	B-3		Rear defogger switch
i19	6	Brown	B-3		Cruise control main switch
i20	4	Blue	B-2	B80	Bulkhead wiring harness
i22	10	*	B-2		Hazard switch
i23	2	Brown	B-2		Glove box illumination light
i24	1	*	C-2		Front accessory power supply
i25	3	*	C-2		
i26	14	*	B-2		Radio
i27	2	*	B-2		CD player illumination light
i28	1	Black	C-2		Ground
i29	1	Black	C-2		Ground (Radio)
i30	4	*	B-2		Rear window defogger timer

\*: Non-colored

### 6. REAR WIRING HARNESS AND GROUND POINT

- LHD model

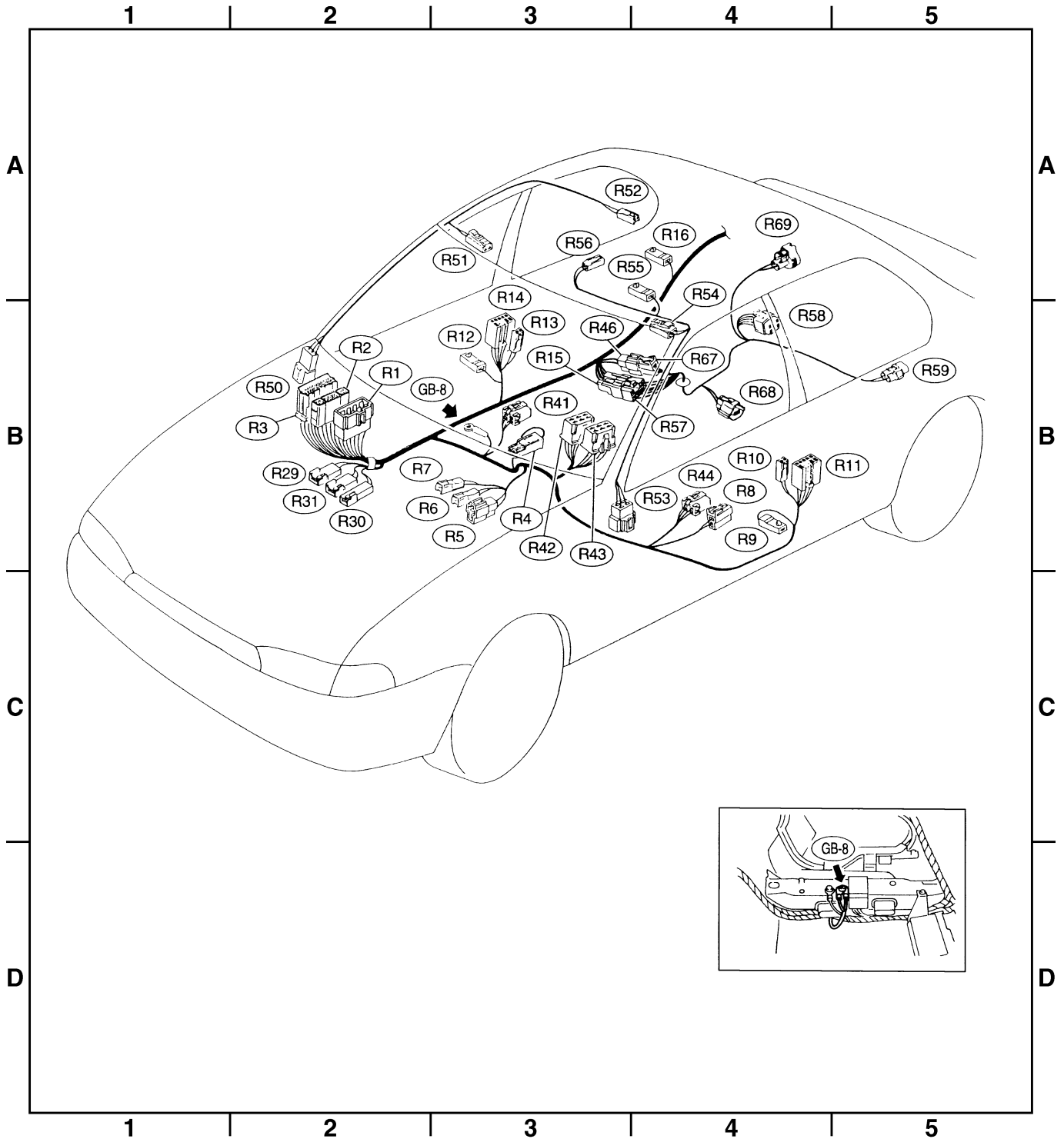

EPA0105

Connector				Connecting to	
No.	Pole	Color	Area	No.	Name
R1	8	*	B-2	B97	Bulkhead wiring harness
R2	24	Black	B-2	B98	Bulkhead wiring harness (2200 cc engine AWD except Taiwan model)
	20	*	B-2	B98	Bulkhead wiring harness (Other models)
R3	24	*	B-2	B99	Bulkhead wiring harness
R4	1	Black	B-2		Parking brake switch
R5	2	*	C-2		Select lever illumination light (AT)
R6	2	Black	C-2		Shift lock solenoid (AT)
R7	2	*	C-2		P position switch (AT)
R8	2	*	C-3		Seat belt switch
R9	1	Brown	C-4		Front door switch LH
R10	2	*	C-4	D22	Rear door cord LH (Security)
R11	8	*	C-4	D21	Rear door cord LH
R12	1	Brown	B-2		Front door switch RH
R13	2	*	B-2	D28	Rear door cord RH (Security)
R14	8	*	B-2	D27	Rear door cord RH
R15	8	*	B-3	R57	Fuel tank cord (2200 cc engine AWD except Taiwan model)
	6	Black	B-3	R57	Fuel tank cord (Other models)
R16	1	Brown	B-3		Rear door switch RH
R29	3	*	C-2		Diode (Security)
R30	2	Black	C-2		Diode (Rear gate latch switch) (Wagon)
R31	3	*	C-2		Diode (Security)
R41	4	Blue	B-2		Seat heater (Passenger)
R42	6	*	B-3		Seat heater switch (Passenger)
R43	6	Blue	B-3		Seat heater switch (Driver)
R44	4	Blue	C-3		Seat heater (Driver)
R46	2	*	B-3	R67	Fuel tank cord (2200 cc engine AWD except Taiwan model)
R50	4	*	B-2	B90	Bulkhead wiring harness
R51	2	*	B-2		Vanity mirror illumination light RH
R52	2	*	A-3		Room light
R53	4	*	C-3	B45	Bulkhead wiring harness
R54	2	*	B-3		Vanity mirror illumination light LH
R55	1	*	B-3		Sunroof control module
R56	2	*	B-3		Spot light
R57	8	*	B-3	R15	Rear wiring harness
R58	6	*	B-3		Fuel gauge module & fuel pump
R59	2	*	B-4		Fuel gauge sub module (AWD)
R67	2	*	B-3	R46	Rear wiring harness
R68	2	*	B-3		Pressure control solenoid valve
R69	2	*	B-3		Vent control solenoid valve

\*: Non-colored



### 6. REAR WIRING HARNESS AND GROUND POINT

- RHD model

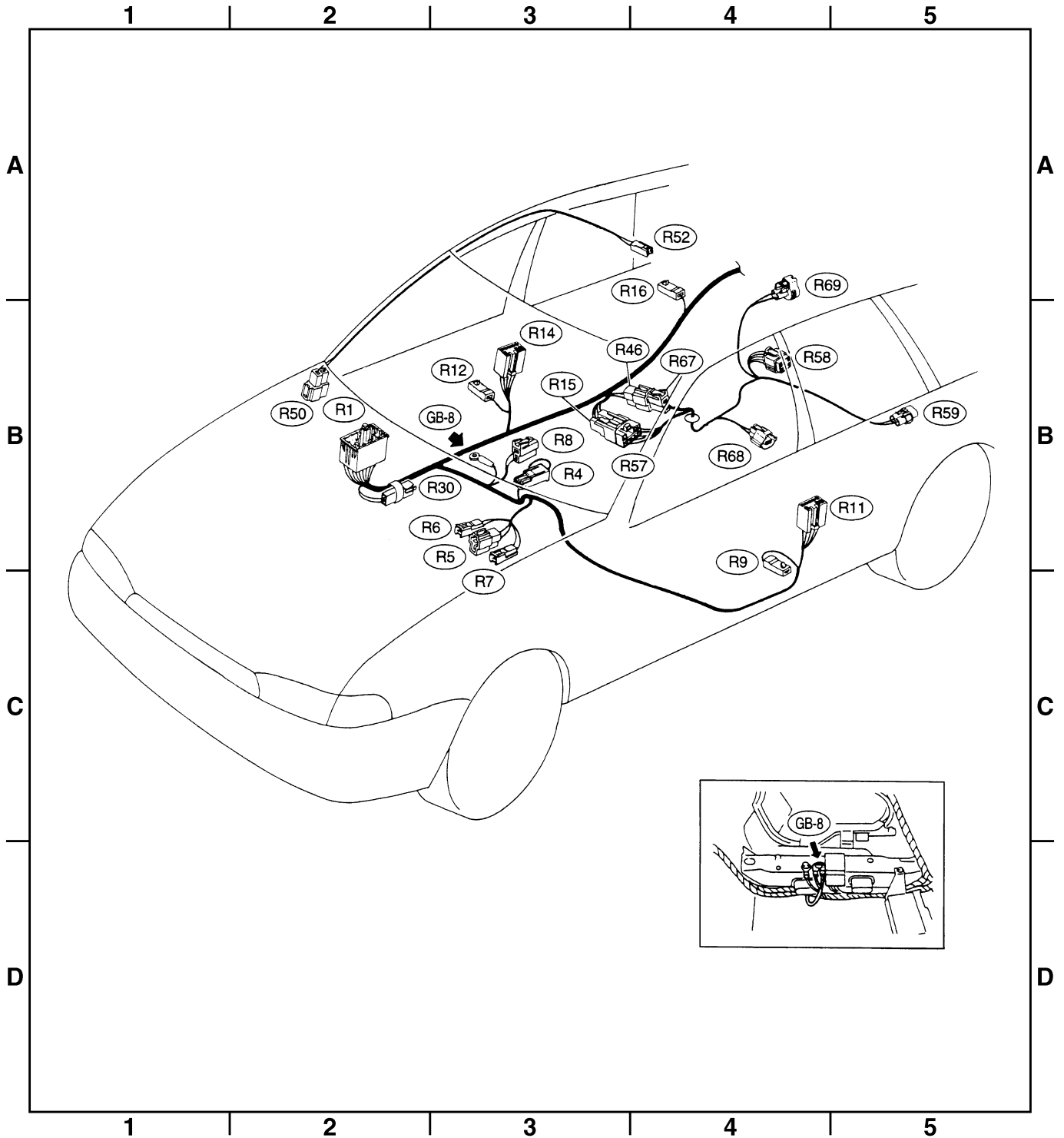

EPA0106

Connector				Connecting to	
No.	Pole	Color	Area	No.	Name
R1	56	*	B-2	B97	Bulkhead wiring harness (S.M.J.)
R4	1	Black	B-2		Parking brake switch
R5	2	*	B-2		Select lever illumination light
R6	2	Black	B-2		Shift lock solenoid
R7	2	*	B-2		P position switch
R8	2	*	B-2		Seat belt switch
R9	1	Brown	B-3		Front door switch LH
R11	8	*	B-4	D21	Rear door cord LH
R12	1	Brown	B-2		Front door switch RH
R14	8	*	B-2	D27	Rear door cord RH
R15	8	*	B-3	R57	Fuel tank cord
R16	1	Brown	A-3		Rear door switch RH
R30	2	Black	B-2		Diode (Rear gate latch switch)
R46	2	*	B-3	R67	Fuel tank cord
R50	2	Green	B-2	B90	Bulkhead wiring harness
R52	2	*	A-3		Room light
R57	8	*	B-3	R15	Rear wiring harness
R58	6	*	A-3		Fuel gauge module & fuel pump
R59	2	*	B-4		Fuel gauge sub module
R67	2	*	B-3	R46	Rear wiring harness
R68	2	*	B-3		Pressure control solenoid valve
R69	2	*	A-3		Vent control solenoid valve

\*: Non-colored

### 7. FLOOR WIRING HARNESS, DOOR CORD AND GROUND POINT

● LHD model

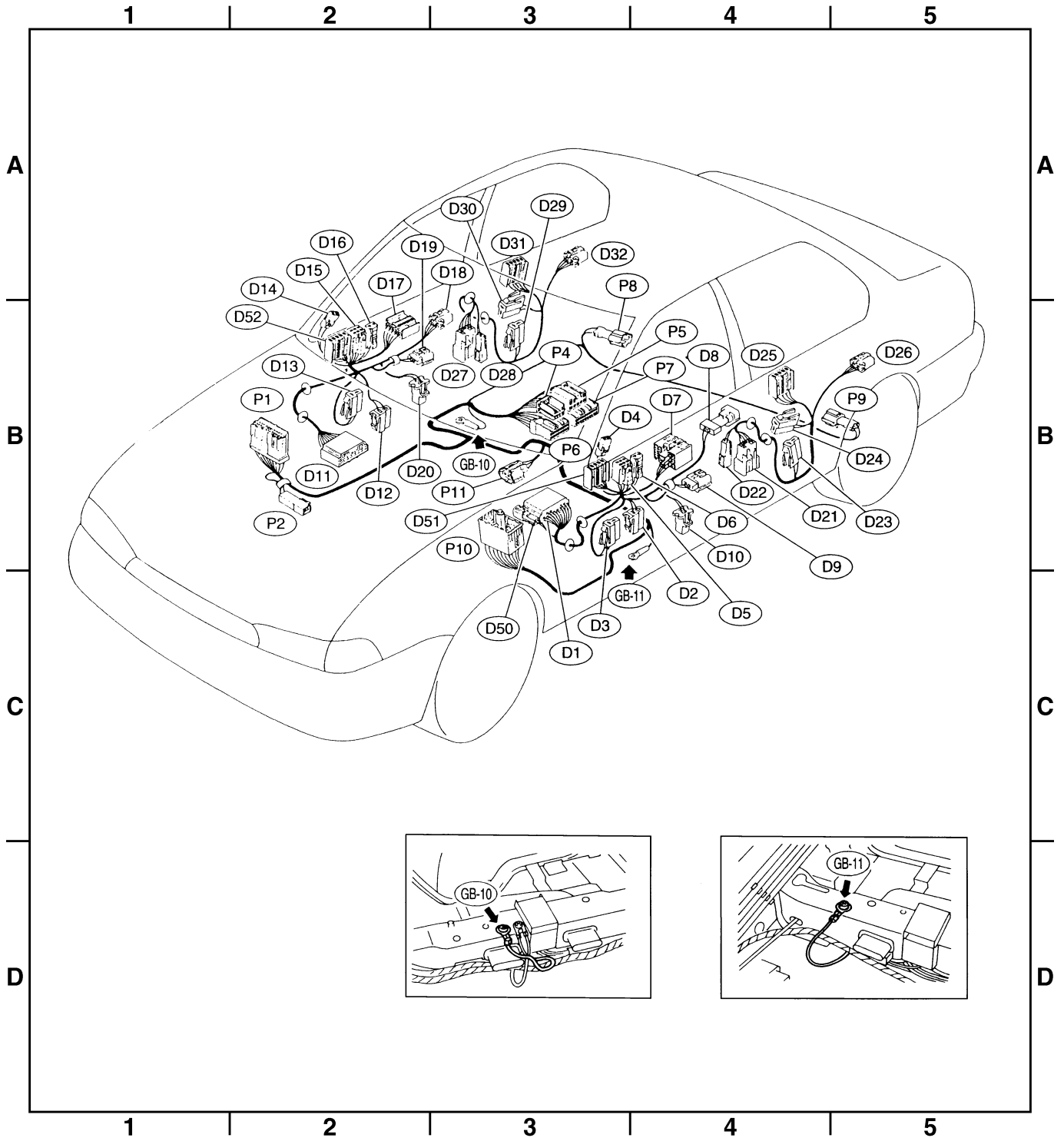

EPA0107

## 8. Electrical Wiring Harness and Ground Point

Connector				Connecting to	
No.	Pole	Color	Area	No.	Name
P1	20	Blue	B-1	F1	Front wiring harness (With TCS model)
	12	*	B-1	F1	Front wiring harness (With ABS model)
P2	2	Black	C-2		Diode (TCS)
P4	6	*	B-3		ABS/TCS control module
P5	8	*	B-3		
P6	16	*	B-3		
P7	20	*	B-3		
P8	2	Gray	B-3		
	2	*	B-3		Rear ABS sensor RH (Outback with step roof)
P9	2	Gray	B-4		Rear ABS sensor LH
	2	*	B-4		Rear ABS sensor LH (Outback with step roof)
P10	40	Gray	B-2	B63	Bulkhead wiring harness (With TCS model)
P11	3	*	B-2		ABS G sensor

Connector				Connecting to	
No.	Pole	Color	Area	No.	Name
D1	24	*	C-3	B30	Bulkhead wiring harness
D2	2	*	C-3		Front door speaker LH
D3	2	Green	C-3		Front power window motor LH
D4	2	Black	B-3		Front tweeter LH
D5	6	*	B-3		Remote control rearview mirror LH
D6	2	*	B-3		Mirror heater LH
D7	14	*	B-3		Power window main switch
D8	4	*	B-3		Front door lock actuator LH
	4	Gray	B-3		Front door lock actuator LH (With security system)
D9	4	Gray	B-3		Front door key switch LH (Security)
D10	2	Black	C-3		Step light LH
D11	24	*	B-2	B101	Bulkhead wiring harness

Connector				Connecting to	
No.	Pole	Color	Area	No.	Name
D12	2	*	B-2		Front door speaker RH
D13	2	Green	B-2		Front power window motor RH
D14	2	Black	B-2		Front tweeter RH
D15	6	*	B-2		Remote control rearview mirror RH
D16	2	*	B-2		Mirror heater RH
D17	5	*	B-2		Front power window sub switch RH
D18	4	*	B-2		Front door lock actuator RH
	4	Gray	B-2		Front door lock actuator RH (With security system)
D19	4	Gray	B-2		Front door key switch RH (Security)
D20	2	Black	B-2		Step light RH
D21	8	*	B-3	R11	Rear wiring harness
D22	2	*	B-3	R10	Rear wiring harness (Security)
D23	2	Black	B-4		Rear door speaker LH
D24	2	Green	B-4		Rear power window motor LH
D25	5	*	B-4		Rear power window sub switch LH
D26	4	*	B-4		Rear door lock actuator LH
	4	Gray	B-4		Rear door lock actuator LH (With security system)
D27	8	*	B-2	R14	Rear wiring harness
D28	2	*	B-2	R13	Rear wiring harness (Security)
D29	2	Black	B-2		Rear door speaker RH
D30	2	Green	B-3		Rear power window motor RH
D31	5	*	A-2		Rear power window sub switch RH
D32	4	*	A-3		Rear door lock actuator RH
	4	Gray	A-3		Rear door lock actuator RH (With security system)
D50	2	*	C-2	B113	Bulkhead wiring harness
D51	5	*	B-3		Front door lock switch LH
D52	5	*	B-2		Front door lock switch RH

\*: Non-colored

### 7. FLOOR WIRING HARNESS, DOOR CORD AND GROUND POINT

- RHD model

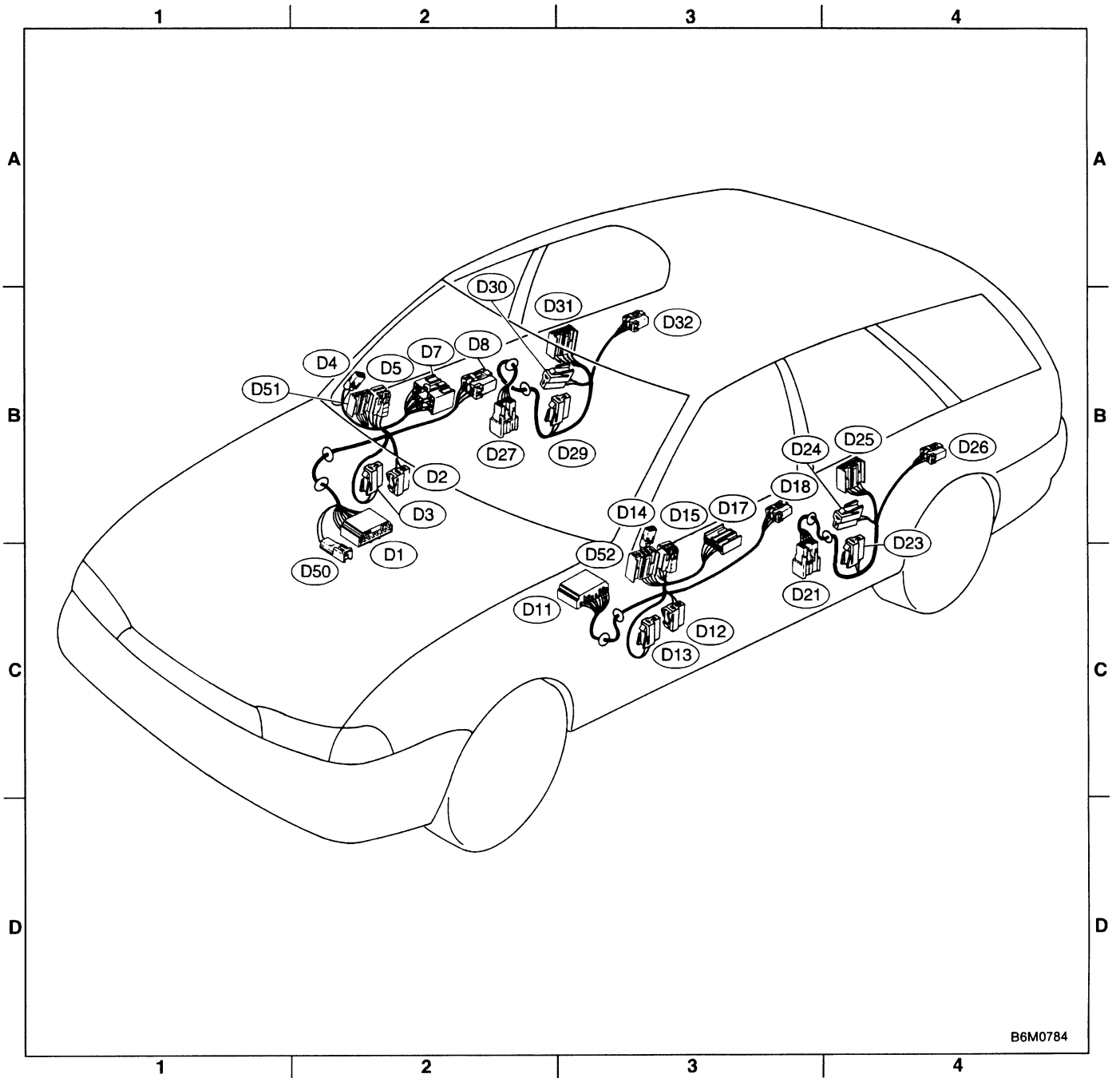

Connector				Connecting to	
No.	Pole	Color	Area	No.	Name
D1	24	*	B-2	B30	Bulkhead wiring harness
D2	2	*	B-2		Front door speaker RH
D3	2	Green	B-2		Front power window motor RH
D4	2	Black	A-2		Front tweeter RH
D5	6	*	B-2		Remote control rearview mirror RH
D7	14	*	B-2		Power window main switch
D8	4	*	A-2		Front door lock actuator RH
D11	24	*	B-3	B101	Bulkhead wiring harness
D12	2	*	B-3		Front door speaker LH
D13	2	Green	B-3		Front power window motor LH
D14	2	Black	B-3		Front tweeter LH
D15	6	*	B-3		Remote control rearview mirror LH
D17	5	*	B-3		Front power window sub switch LH
D18	4	*	B-3		Front door lock actuator LH
D21	8	*	B-3	R11	Rear wiring harness
D23	2	Black	B-4		Rear door speaker LH
D24	2	Green	B-4		Rear power window motor LH
D25	5	*	B-4		Rear power window sub switch LH
D26	4	*	B-4		Rear door lock actuator LH
D27	8	*	B-2	R14	Rear wiring harness
D29	2	Black	B-3		Rear door speaker RH
D30	2	Green	A-3		Rear power window motor RH
D31	5	*	A-3		Rear power window sub switch RH
D32	4	*	A-3		Rear door lock actuator RH
D50	2	*	B-2	B113	Bulkhead wiring harness
D51	5	Green	B-2		Front door lock switch RH
D52	5	Green	C-3		Front door lock switch LH

\*: Non-colored

8. REAR END WIRING HARNESS AND GROUND POINT OF SEDAN

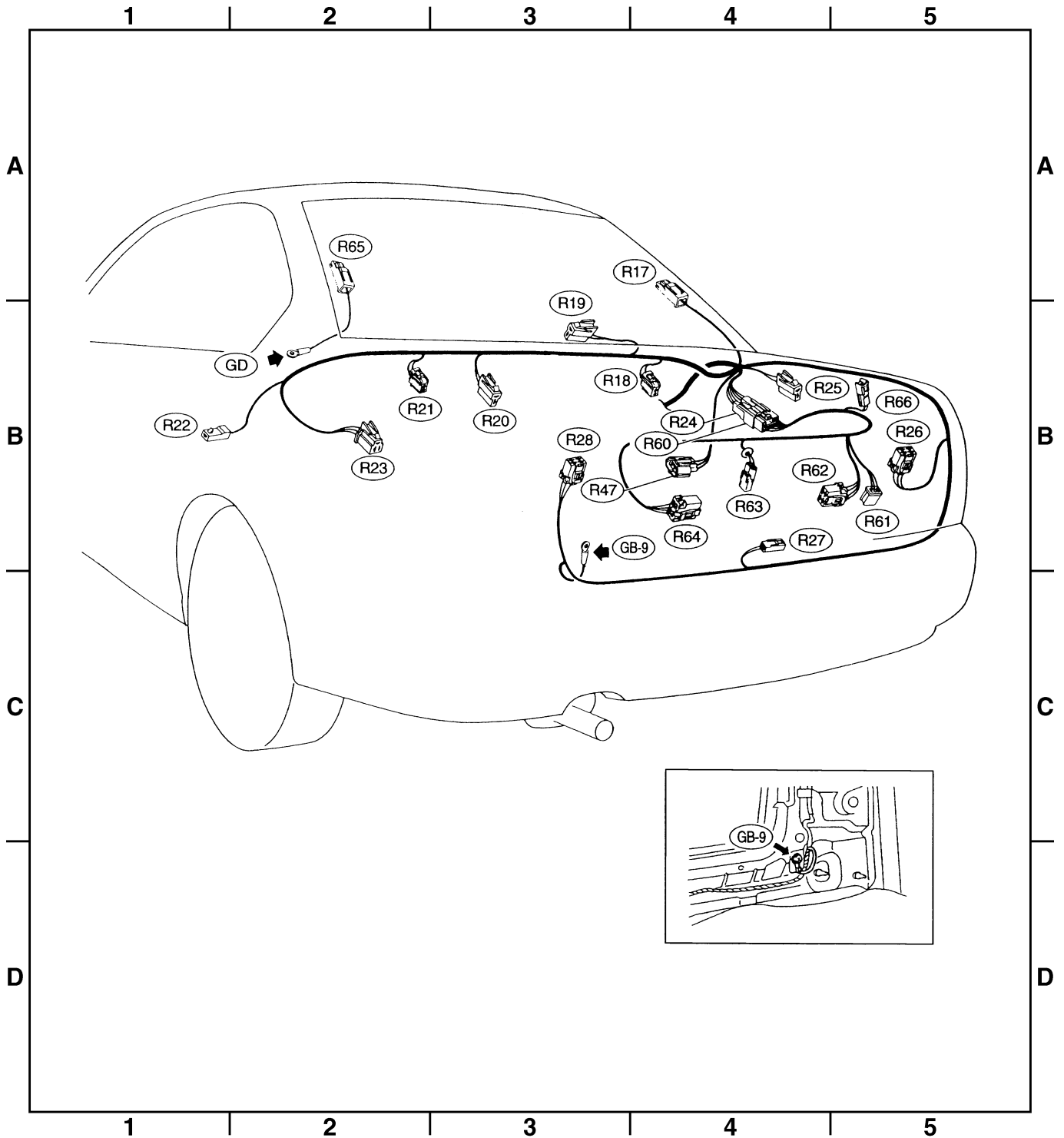

EPA0108

Connector				Connecting to	
No.	Pole	Color	Area	No.	Name
R17	1	Black	A-3		Rear defogger (Power)
R18	2	Black	B-3		Rear speaker RH
R19	2	*	B-3		High-mounted stop light
R20	2	Blue	B-2		Trunk room light
R21	2	Black	B-2		Rear speaker LH
R22	1	Brown	B-1		Rear door switch LH
R23	3	*	B-2		Power antenna
R24	6	*	B-3	R60	Trunk lid cord (Without security system)
	8	*	B-3	R60	Trunk lid cord (With security system)
R25	2	Black	B-4		Rear defogger condenser
R26	4	*	B-4		Rear combination light RH
R27	2	*	B-4		Trunk room light switch
R28	4	*	B-3		Rear combination light LH
R47	3	*	B-3		Fuel tank pressure sensor
R60	6	*	B-4	R24	Rear wiring harness (Without security system)
	8	*	B-4	R24	Rear wiring harness (With security system)
R61	3	*	B-4		Key switch (Security)
R62	4	*	B-4		Rear finisher light RH
R63	2	*	B-3		License plate light
R64	4	*	B-3		Rear finisher light LH
R65	1	Black	A-2		Rear defogger (Ground)
R66	2	Black	B-4		High-mounted stop light (Rear spoiler)

\*: Non-colored



9. REAR END WIRING HARNESS AND GROUND POINT OF WAGON

● LHD model

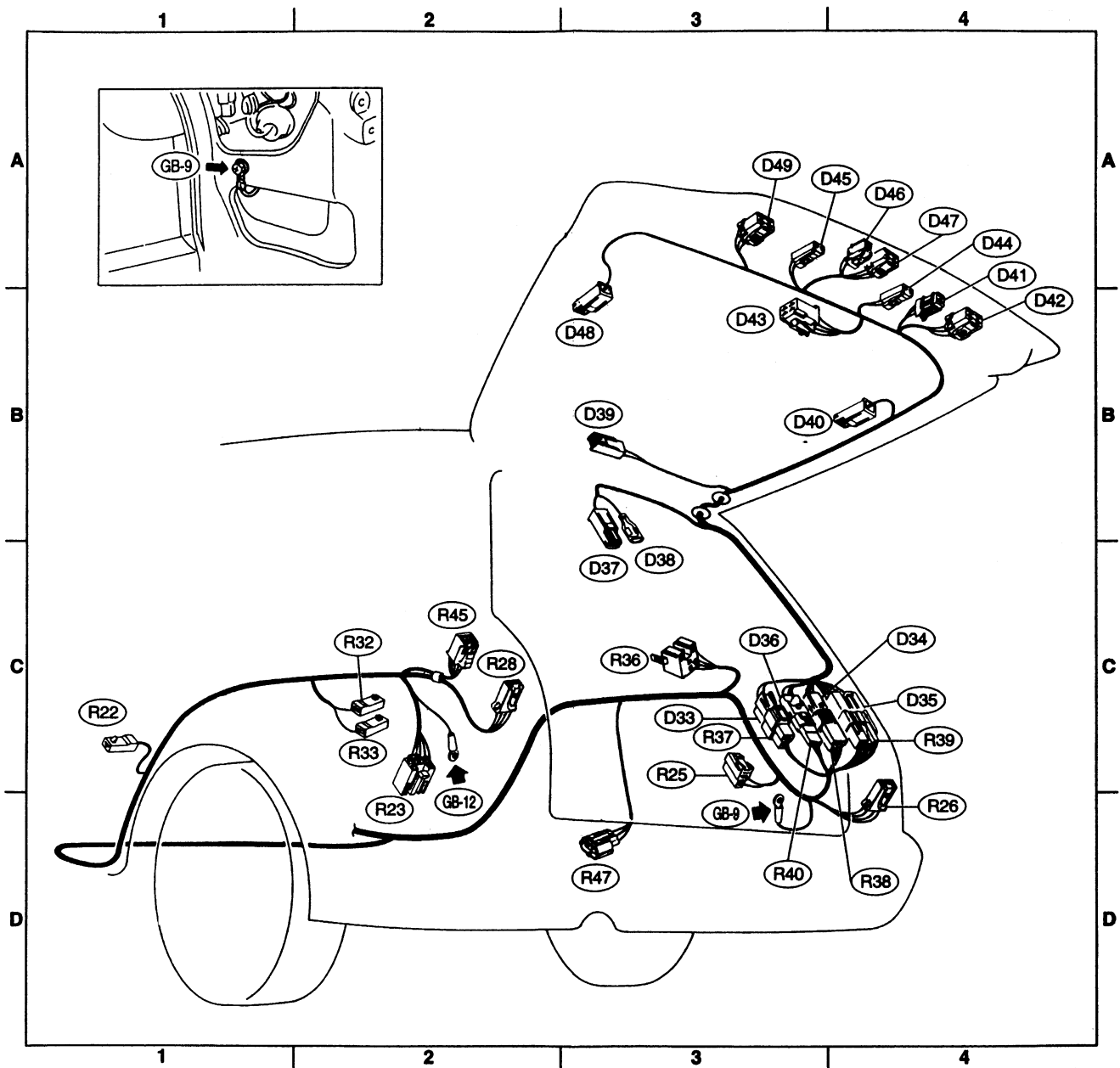

B6M0694A

Connector				Connecting to	
No.	Pole	Color	Area	No.	Name
R22	1	Brown	C-1		Rear door switch LH
R23	6	*	C-2		Power antenna
R25	2	Black	C-3		Rear defogger condenser
R26	4	Black	D-4		Rear combination light RH
R28	4	Black	C-2		Rear combination light LH
R32	1	*	C-2		Rear accessory power supply (Power)
R33	1	Black	C-2		Rear accessory power supply (Ground)
R36	5	Black	C-3		Rear wiper relay
R37	2	*	C-3	D33	Rear gate cord
R38	4	*	C-3	D34	
R39	8	*	C-4	D35	
R40	4	Black	C-3	D36	Rear gate cord (With security)
R45	6	*	C-2		Trailer connector (Outback with step roof)
R47	3	*	D-3		Fuel tank pressure sensor

Connector				Connecting to	
No.	Pole	Color	Area	No.	Name
D33	2	*	C-3	R37	Rear wiring harness
D34	4	*	C-3	R38	
D35	8	*	C-4	R39	
D36	4	Black	C-3	R40	Rear wiring harness (With security)
D37	1	Black	B-3		Luggage room light
D38	1	*	B-3		
D39	2	*	B-3		High-mounted stop light
D40	1	Black	B-4		Rear defogger (Power)
D41	4	Gray	B-4		Key switch (Security)
D42	4	*	B-4		Rear finisher light RH
D43	4	*	B-3		Rear wiper motor
D44	2	*	B-4		License plate light RH
D45	2	*	A-3		License plate light LH
D46	2	Black	A-4		Rear gate latch switch
D47	4	*	A-4		Rear gate lock actuator (Without security system)
	4	Gray	A-4		Rear gate lock actuator (With security system)
D48	1	Black	B-3		Rear defogger (Ground)
D49	4	*	A-3		Rear finisher light LH

\*: Non-colored

9. REAR END WIRING HARNESS AND GROUND POINT OF WAGON

● RHD model

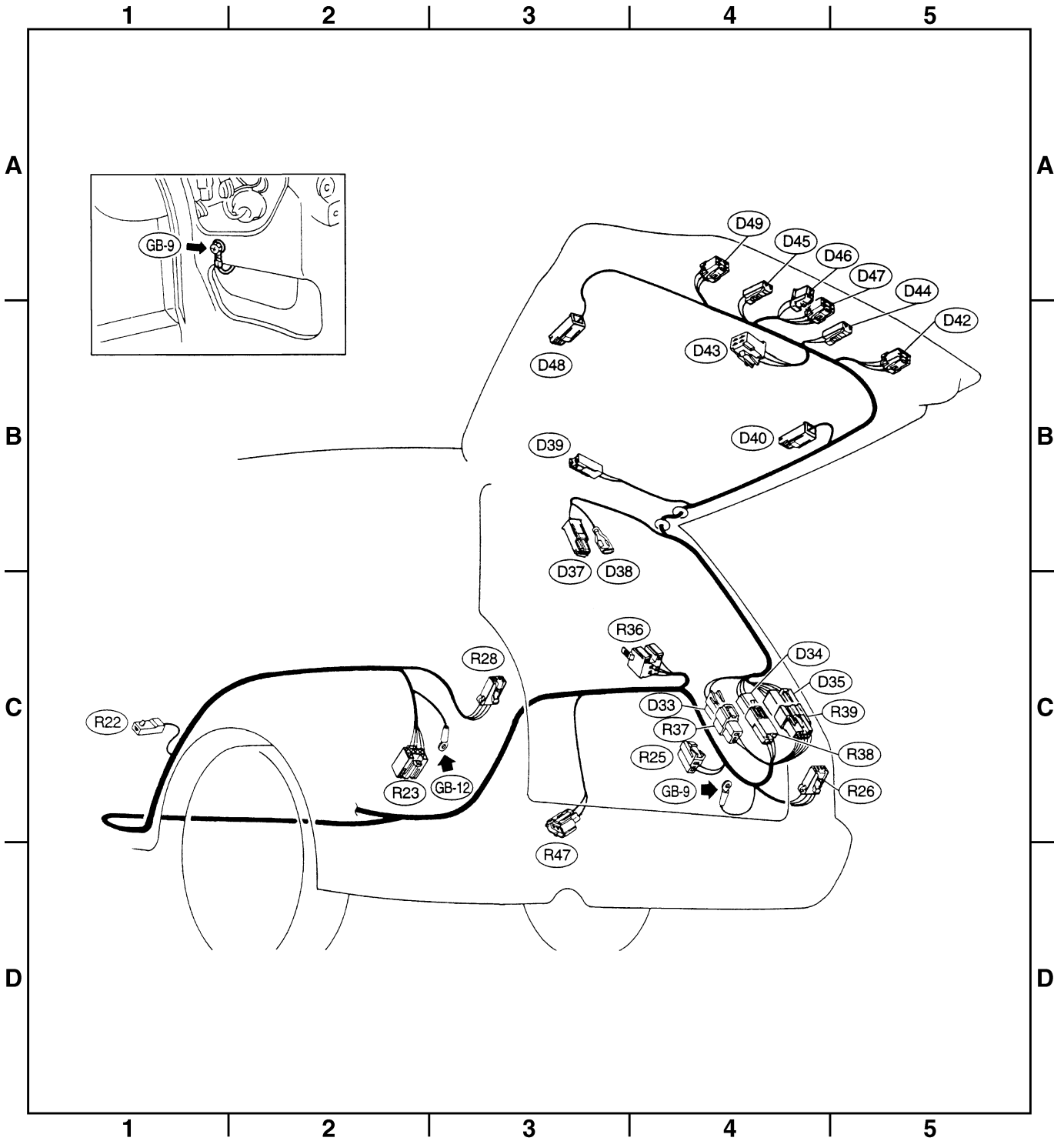

EPA0109

Connector				Connecting to	
No.	Pole	Color	Area	No.	Name
R22	1	Brown	C-1		Rear door switch LH
R23	6	*	C-2		Power antenna
R25	2	Black	C-3		Rear defogger condenser
R26	4	Black	D-4		Rear combination light RH
R28	4	Black	C-2		Rear combination light LH
R36	5	Black	C-3		Rear wiper relay
R37	2	*	C-3	D33	Rear gate cord
R38	4	*	C-3	D34	
R39	8	*	C-4	D35	
R47	3	*	D-3		Fuel tank pressure sensor

Connector				Connecting to	
No.	Pole	Color	Area	No.	Name
D33	2	*	C-3	R37	Rear wiring harness
D34	4	*	C-3	R38	
D35	8	*	C-4	R39	
D37	1	Black	B-3		Luggage room light
D38	1	*	B-3		
D39	2	*	B-3		High-mounted stop light
D40	1	Black	B-4		Rear defogger (Power)
D42	4	*	B-4		Rear finisher light RH
D43	4	*	B-3		Rear wiper motor
D44	2	*	B-4		License plate light RH
D45	2	*	A-3		License plate light LH
D46	2	Black	A-4		Rear gate latch switch
D47	4	*	A-4		Rear gate lock actuator
D48	1	Black	B-3		Rear defogger (Ground)
D49	4	*	A-3		Rear finisher light LH

\*: Non-colored