

Seat, seat belt and SRS AIRBAG

Front seats	2-2
<i>Fore and aft adjustment</i>	2-4
<i>Reclining the seatback</i>	2-4
<i>Height adjustment (if equipped)</i>	2-5
<i>Head restraint adjustment</i>	2-5
<i>Lumbar support (if equipped)</i>	2-6
<i>Seat heater (if equipped)</i>	2-7
Rear seats	2-8
<i>Fold down rear seat — Sedan</i>	2-9
<i>Fold down rear seat — Wagon</i>	2-10
3-point type seat belts (combination lap/shoulder belts) ...	2-14
<i>Seat belt warning light and chime</i>	2-16
<i>Emergency Locking Retractor (ELR) function</i>	2-16
<i>Automatic Locking Retractor (ALR) function</i>	2-16
<i>Fastening the seat belt</i>	2-17
<i>Unfastening the belt</i>	2-18
<i>Adjusting the front seat shoulder belt anchor height</i>	2-18
2-point type seat belts (lap only belts)	2-19
<i>Fastening the seat belt</i>	2-20
<i>Unfastening the belt</i>	2-21
Seat belt safety tips	2-22
<i>Infants or small children</i>	2-22
<i>Children</i>	2-22
<i>Expectant mothers</i>	2-23
<i>Maintenance</i>	2-23
Child restraint systems	2-24
<i>Installing child restraint systems in the 2-point type seat belt position (Rear center seating position)</i>	2-26
<i>Installing child restraint systems in the 3-point type seat belt position</i>	2-27
<i>Top strap anchors</i>	2-28
SRS AIRBAG (Supplemental Restraint System Airbag)	2-30
<i>Vehicle with driver's and passenger's SRS AIRBAGs and lap/shoulder restraints</i>	2-30
<i>SRS AIRBAG system operation</i>	2-34
<i>System monitors</i>	2-38
<i>System servicing</i>	2-39
<i>Precautions for vehicle modification</i>	2-40

Front seats



WARNING

- Never adjust the seat while driving to avoid the possibility of loss of vehicle control and of personal injury.
- Never drive the vehicle with the head restraints removed because they are designed to reduce the risk of serious neck injury in the event that the vehicle is struck from the rear.
- Before adjusting the seat, make sure the hands and feet of rear seat passengers are clear of the adjusting mechanism.
- Seat belts provide maximum restraint when the occupant sits well back and upright in the seat. To reduce the risk of sliding under the seat belt in a collision, the front seatbacks should be always used in the upright position while the vehicle is running. If the front seatbacks are not used in the upright position in a collision, the risk of sliding under the lap belt and of the lap belt sliding up over the abdomen will increase, and both can result in serious internal injury or death.
- Do not put cushions or any other materials between occupants and seatbacks or seat cushions. If you do so, the risk of sliding under the lap belt and of the lap belt sliding up over the abdomen will increase, and both can result in serious internal injury or death.
- The SRS AIRBAGs deploy with considerable speed and force. Occupants who are out of proper position when the SRS AIRBAG deploys could suffer very serious injuries. Because the SRS AIRBAG needs much space for deployment, the driver should always sit upright and well back in the seat as far from the steering wheel as practical while still maintaining full vehicle control and the front passenger should move the seat as far back as possible and sit upright and well back in the seat.
- Be sure to put children aged 12 and under in the rear seat properly restrained at all times. The SRS AIRBAG deploys with considerable speed and force and can injure or even kill children, especially if they are 12 years of age and under and are not restrained or improperly restrained. Because children are lighter and weaker

than adults, their risk of being injured from deployment is greater. For that reason, we strongly recommend that ALL children (including those in child seats and those that have outgrown child restraint devices) sit in the REAR seat properly restrained at all times in a child restraint device or in a seat belt, whichever is appropriate for the child's age, height and weight. Be sure to secure ALL types of child restraint devices (including forward facing child seat) in the REAR seats at all times. NEVER INSTALL A REARWARD FACING CHILD SEAT IN THE FRONT SEAT. DOING SO RISKS SERIOUS INJURY OR DEATH TO THE CHILD BY PLACING THE CHILD'S HEAD TOO CLOSE TO THE SRS AIRBAG. According to accident statistics, children are safer when properly restrained in the rear seating positions than in the front seating positions. For instructions and precautions concerning child restraint systems, see the Child Restraint System section in this chapter.

Adjust the seatback to upright position. Sit well back and upright.

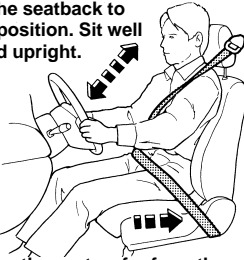

Move the seat as far from the steering wheel as practical.

HS0233

Adjust the seatback to upright position. Sit well back and upright.

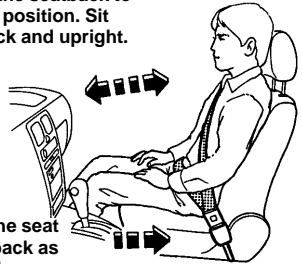

Move the seat as far back as possible.

HS0290

Put children in the rearseat properly restrained at all times.



HS0291

⚠ Do not recline the seatback while vehicle is moving.

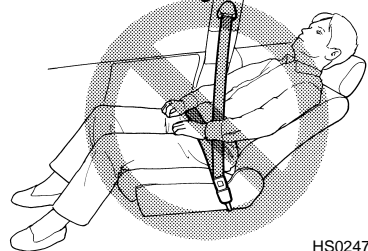

HS0247

- CONTINUED -

⚠ CAUTION

Metallic parts of the seat belt can become very hot in a vehicle that has been closed up in sunny weather; they could burn an occupant. Do not touch such hot parts.

■ **Fore and aft adjustment**

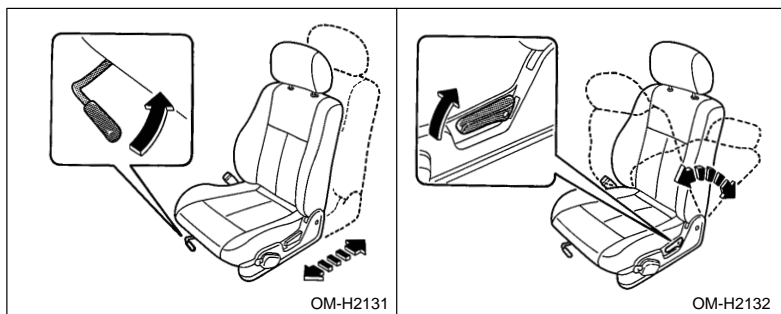

Pull the lever upward and slide the seat to the desired position. Then release the lever and move the seat back and forth to make sure that it is securely locked into place.

■ **Reclining the seatback**

Pull the reclining lever up and adjust the seatback to the desired position. Then release the lever and make sure the seatback is securely locked into place.

■ Height adjustment (if equipped)

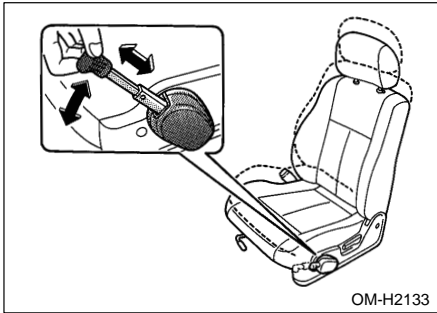

Pull the adjustment lever out and move it up or push it down to raise or lower the seat.

■ Head restraint adjustment

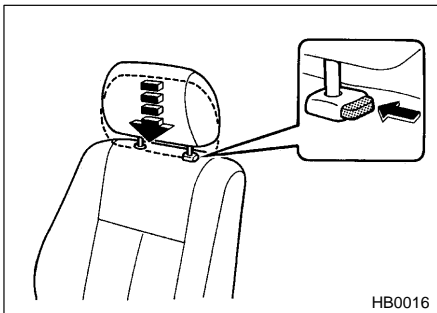

To raise the head restraint, pull it up. To lower it, push the head restraint down while depressing the release button on the top of the seatback.

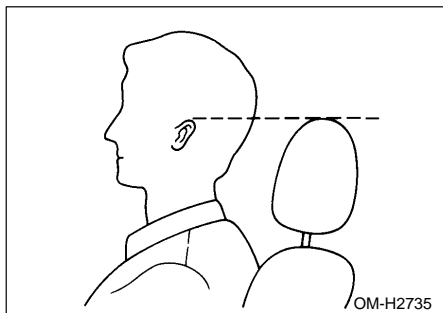

The best position for the head restraint is just above or level with the top of the ears.

■ **Lumbar support (if equipped)**

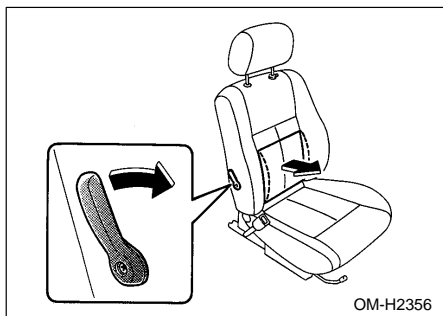

Pull the lever forward or backward.

Pulling the lever forward will increase the amount of support for your lower back.

■ Seat heater (if equipped)

CAUTION

- Do not use the seat heater when the engine is not running. The battery could run down if the heater is operated while the engine is not running.
- Do not put anything on the seat which insulates against heat, such as a blanket, cushion, or similar items. This may cause the seat heater to overheat.
- When cleaning the seat, do not use benzine, paint thinner, or any similar materials.

The seat heater operates when the ignition switch is either in the “ACC” or “ON” position.

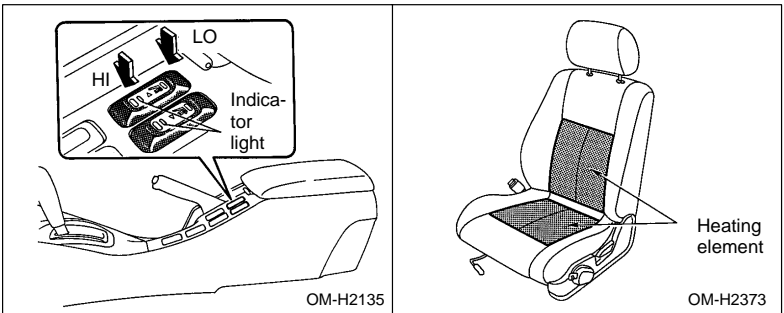

To turn on the seat heater, push the “LO” or “HI” position on the switch, as desired, depending on the temperature.

LO: Normal heating

HI: Rapid heating

The indicator located on the switch comes on when the seat heater is in operation. When the vehicle’s interior is warmed enough or before you leave the vehicle, be sure to turn the switch off.

Rear seats

WARNING

- Seat belts provide maximum restraint when the occupant sits well back and upright in the seat. Do not put cushions or any other materials between occupants and seatbacks or seat cushions. If you do so, the risk of sliding under the lap belt and of the lap belt sliding up over the abdomen will increase, and both can result in serious internal injury or death.
- Never allow passengers to ride on the folded rear seatback, in the trunk or in the cargo area. Doing so may result in serious injury.
- Never stack luggage or other cargo higher than the top of the seatback because it could tumble forward and injure passengers in the event of a sudden stop or accident.
- Secure skis and other lengthy items properly to prevent them from shooting forward and causing serious injury during a sudden stop.

Sit well back
and upright.



HB0302



CAUTION

Metallic parts of the seat belt can become very hot in a vehicle that has been closed up in sunny weather; they could burn a occupant. Do not touch such hot parts.

■ Fold down rear seat — Sedan

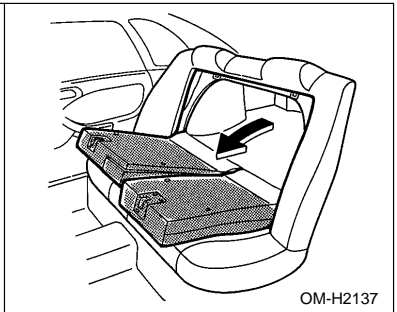
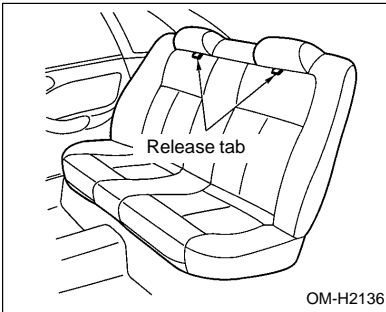

To fold the seatback down, pull the release tab attached to the top of the seatback. To restore it, push the seatback up to its original position until it locks. Be sure to confirm that it is locked in place.

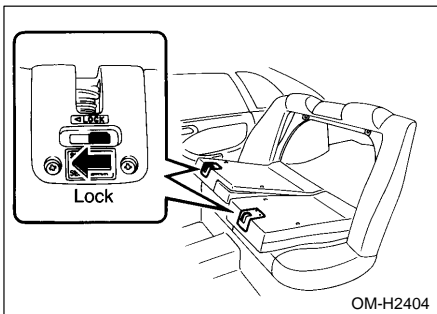

To cancel the fold down function, slide the lock knob located on the backside of the seatback to the “LOCK” position and close the seatback.

– CONTINUED –

▼ **Armrest (if equipped)**

⚠ WARNING

To avoid the possibility of serious injury, passengers must never be allowed to sit on the center armrest while the vehicle is in motion.

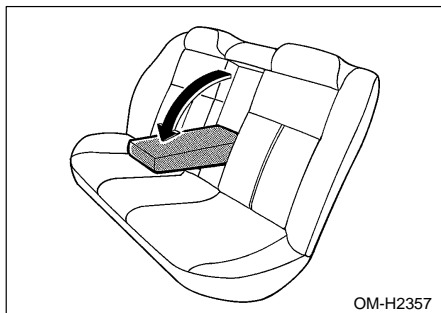

To lower the armrest, pull on the top edge of the armrest.

■ **Fold down rear seat — Wagon**

⚠ WARNING

After returning the rear seat to its original position, be certain to place all of the seat belts and the tab attached to the seat cushion above the seat cushion. And make certain that the shoulder belts are fully visible.

▼ **Folding down the seatback**

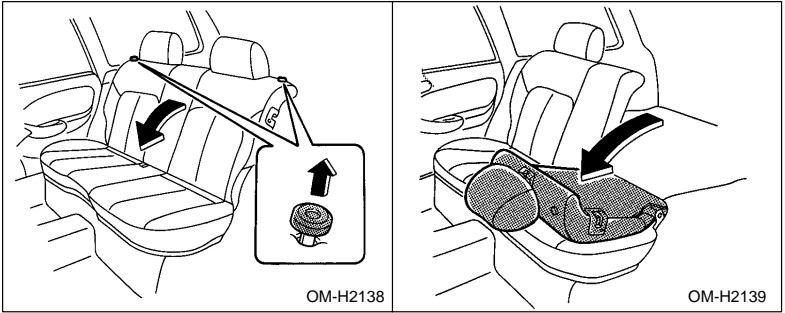

Unlock the seatback by pulling the release knob and fold it down.

▼ **Folding down the seat cushion and seatback**

1. Move the front seat forward.
2. (If your vehicles' rear seatbacks are equipped with head restraints.) To remove the head restraint, pull the head restraint up while pushing the release button located on the backside of the set-back.

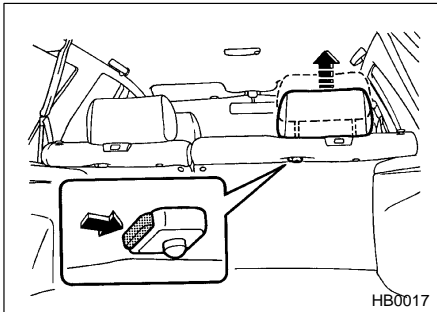

3. Store the seat belts in the seat belt pocket to prevent them falling below the cushion.

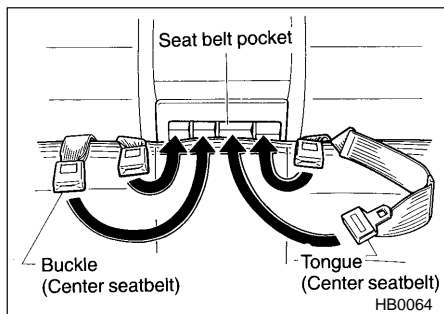

4. Raise the seat cushion by pulling up the tab.

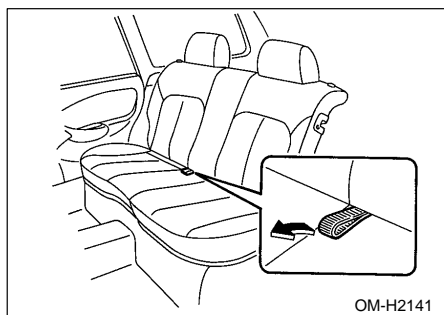

5. Unlock the seatback by pulling the release knob and fold it down. Confirm that the pin located at the bottom of the seat cushion is inserted into the slot at the top of the seatback.

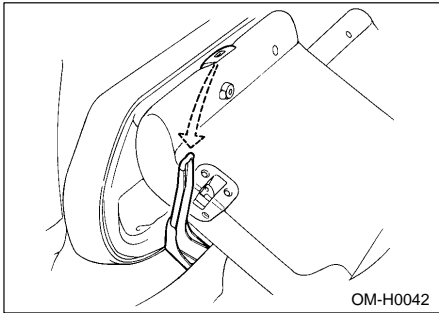

6. Install the head restraints onto the backside of the seatback.

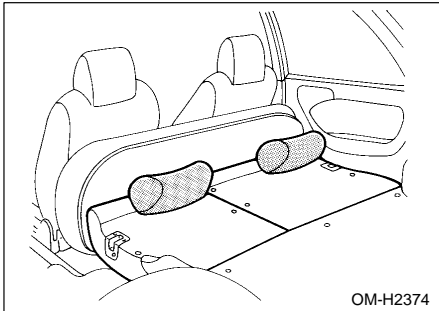

To return the rear seat to its original position, raise the seatback and seat cushion until it locks into place and make sure that they are securely locked.

Make sure that the rear seat belts are not under the seat cushion or seatback.

Place the head restraints (if so equipped) back in their normal position.

3-point type seat belts (Combination lap/shoulder belts)

WARNING

- Never use a belt that is twisted or reversed. In an accident, this can increase the risk or severity of injury.
- Never place the shoulder belt under the arm or behind the back. If an accident occurs, this can increase the risk or severity of injury.
- Keep the lap belt as low as possible on your hips. In a collision, this spreads the force of the lap belt over stronger hip bones instead of across the weaker abdomen.
- Seat belts provide maximum restraint when the occupant sits well back and upright in the seat. To reduce the risk of sliding under the seat belt in a collision, the front seatbacks should be always used in the upright position while the vehicle is running. If the front seatbacks are not used in the upright position in a collision, the risk of sliding under the lap belt and of the lap belt sliding up over the abdomen will increase, and both can result in serious internal injury or death.
- Do not put cushions or any other materials between occupants and seatbacks or seat cushions. If you do so, the risk of sliding under the lap belt and of the lap belt sliding up over the abdomen will increase, and both can result in serious internal injury or death.
- Be sure to put children aged 12 and under in the rear seat properly restrained at all times. The SRS AIRBAG deploys with considerable speed and force and can injure or even kill children, especially if they are 12 years of age and under and are not restrained or improperly restrained. Because children are lighter and weaker than adults, their risk of being injured from deployment is greater. For that reason, we strongly recommend that ALL children (including those in child seats and those that have outgrown child restraint devices) sit in the REAR seat properly restrained at all times in a child restraint device or in a seat belt, whichever is appropriate for the child's age, height and weight. Be sure to secure

ALL types of child restraint devices (including forward facing child seats) in the REAR seats at all times. NEVER INSTALL A REARWARD FACING CHILD SEAT IN THE FRONT SEAT. DOING SO RISKS SERIOUS INJURY OR DEATH TO THE CHILD BY PLACING THE CHILD'S HEAD TOO CLOSE TO THE SRS AIRBAG. According to accident statistics, children are safer when properly restrained in the rear seating positions than in the front seating positions. For instructions and precautions concerning child restraint systems, see the Child Restraint System section in this chapter.

Always wear the seat belts correctly.

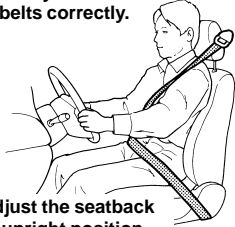

Adjust the seatback to upright position. Sit well back and upright.

HS0230



Never place the shoulder belt under the arm or behind the back.

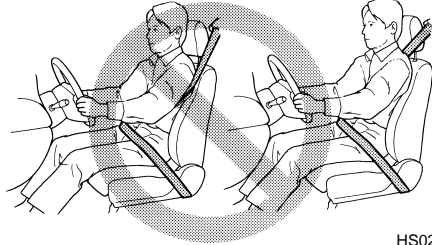

HS0231

CAUTION

Metallic parts of the seat belt can become very hot in a vehicle that has been closed up in sunny weather; they could burn an occupant. Do not touch such hot parts.

■ Seat belt warning light and chime

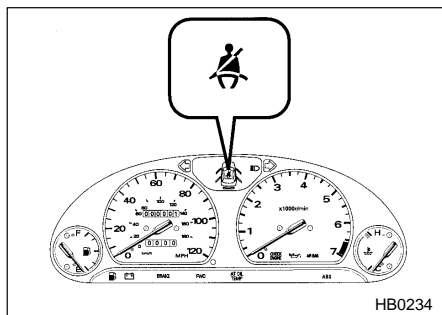

Your vehicle is equipped with a seat belt warning device at the driver's seat.

This device causes the seat belt warning light on the instrument panel to light up for about six seconds when the ignition switch is turned to the "ON" position to remind the driver to wear the seat belt. If the driver's seat belt is not fastened, a warning chime sounds at the same time.

■ Emergency Locking Retractor (ELR) function

3-point type seat belts have an emergency locking retractor. This allows normal body movement but the retractor locks automatically during a sudden stop, impact or if you pull the belt very quickly out of the retractor.

■ Automatic Locking Retractor (ALR) function

When securing a child restraint system on the passengers' seats, the three-point type seat belt must be changed over to the Automatic Locking Retractor (ALR) mode.

When the child restraint system is removed, make sure that the retractor operates as an Emergency Locking Retractor (ELR).

For instructions on how to convert the retractor to the ALR mode and restore it to the ELR mode, see the "Child Restraint System" section in this chapter.

■ Fastening the seat belt



CAUTION

Metallic parts of the seat belt can become very hot in a vehicle that has been closed up in sunny weather; they could burn an occupant. Do not touch such hot parts.

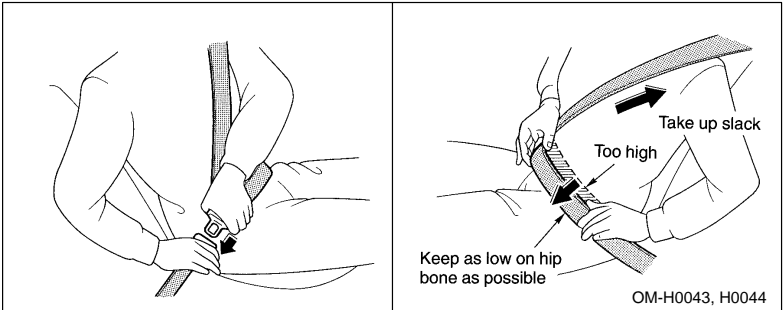

1. Adjust the seat position:

Driver's seat: Move the seat back as far from the steering wheel as practical while still maintaining full vehicle control and adjust the seatback to the upright position.

Front passenger's seat: Move the seat as far back as possible and adjust the seatback to the upright position.

2. Sit well back in the seat.

3. Pick up the tongue plate and pull the belt out slowly. Do not let it get twisted. If the belt stops before reaching the buckle, return the belt slightly and pull it out more slowly.

4. Insert the tongue plate into the buckle until you hear a click.

For the driver's side seat belt, a seat belt warning device is provided; if the driver is not wearing the seat belt with the ignition in the "ON" position, the warning light on the instrument panel comes on and a warning chime also sounds to remind the driver to wear the seat belt.

Refer to Warning and Indicator Lights section (chapter 3) for more details.

– CONTINUED –

5. To make the lap part tight, pull up on the shoulder belt. And place the lap belt as low as possible on your hips, not on your waist.

■ Unfastening the belt

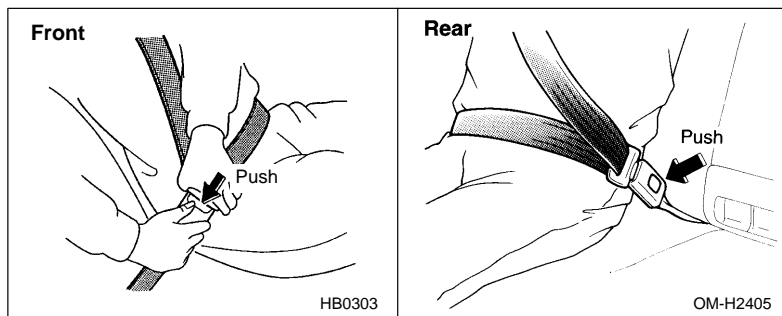

Push the button on the buckle.

Before closing the door, make sure that the belts are retracted properly, to avoid catching the belt webbing in the door.

■ Adjusting the front seat shoulder belt anchor height

WARNING

When wearing the front seat belts, make sure the shoulder portion of the webbing does not pass over your neck. If it does, adjust the seat belt anchor to a lower position. Placing the shoulder belt over the neck may result in neck injury during sudden braking or in a collision.

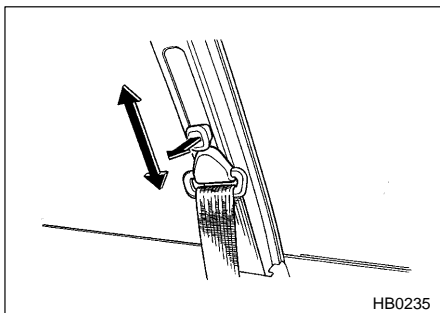

The shoulder belt anchor height should be adjusted to the position best for you. To adjust the anchor height, pull the release knob and move the anchor to the desired position so that the shoulder belt passes over the middle of the shoulder without touching the neck.

2-point type seat belts (lap only belts)



WARNING

- **Seat belts provide maximum restraint when the occupant sits well back and upright in the seat. Do not put cushions or any other materials between occupants and seatbacks or seat cushions. If you do so, the risk of sliding under the lap belt and of the lap belt sliding up over the abdomen will increase, and both can result in serious internal injury or death.**
- **Never use a belt that is twisted or reversed. In an accident, this can increase the risk or severity of injury.**
- **Keep the lap belt as low as possible on your hips. In a collision, this spreads the force of the lap belt over stronger hip bones instead of across the weaker abdomen.**

Always wear the seat belts correctly.



Sit well back and upright.

HB0304



CAUTION

Metallic parts of the seat belt can become very hot in a vehicle that has been closed up in sunny weather; they could burn an occupant. Do not touch such hot parts.

The 2-point type seat belt has a manual adjustment device.

■ Fastening the seat belt

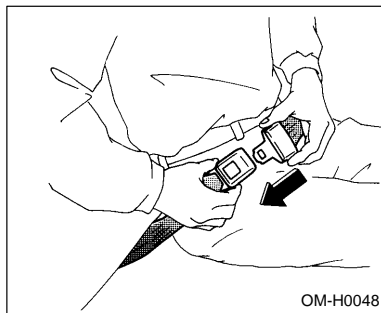

OM-H0048

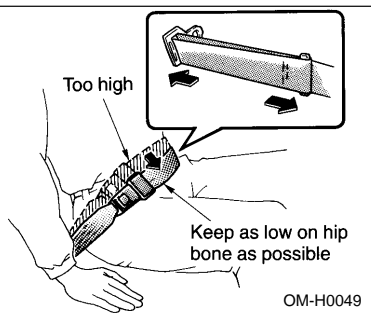

OM-H0049

1. Sit well back in the seat and pick up the tongue plate marked "CENTER". Be careful not to twist the belt.
2. Insert the tongue plate into the buckle marked "CENTER" until you hear a click. The tongue plate marked "CENTER" can be fastened only into the buckle marked "CENTER". If the belt is not long enough for you,

hold the tongue plate at a right angle to the belt and pull the belt to extend.

3. To make the belt tight, pull up on the belt. And place the lap belt as low as possible on your hips, not on your waist.

■ Unfastening the belt

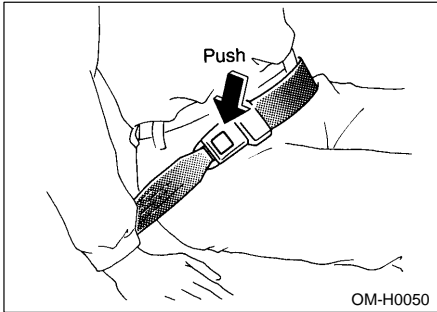

Push the button on the buckle.

When the belt is not in use, buckle the belt to prevent it from being caught in the door.

NOTE

When folding down the rear seat of the wagon, store the seat belts in the seat belt pocket to prevent them falling below the cushion.

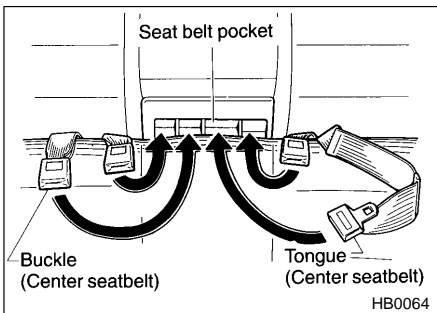

Seat belt safety tips

WARNING

- All persons in the vehicle should fasten their seat belts **BEFORE** the vehicle starts to move. Otherwise, the possibility of serious injury becomes greater in the event of a sudden stop or accident.
- All belts should fit snugly in order to provide full restraint. Loose fitting belts are not as effective in preventing or reducing injury.
- Each seat belt is designed to support only one person. Never use a single belt for two or more persons — even children. Otherwise, in an accident, serious injury or death could result.
- Replace all seat belt assemblies including retractors and attaching hardware worn by occupants of a vehicle that has been in a serious accident. The entire assembly should be replaced even if damage is not obvious.

■ **Infants or small children**

Use a child restraint system that is suitable for your vehicle. See information on “Child Restraint System” in this chapter.

■ **Children**

If a child is too big for a child restraint system, the child should sit in the rear seat and be restrained using the seat belts. According to accident statistics, children are safer when properly restrained in the rear seating positions than in the front seating positions. Never allow a child to stand up or kneel on the seat.

If the shoulder portion of the belt crosses the face or neck, move the child closer to the center of vehicle to help provide a good shoulder belt fit. If the shoulder portion of the belt cannot be properly positioned, a child restraint system should be used. If that is not possible, the child should sit in the center rear seat and use the 2-point type seat belt. Care must be taken to securely place the lap belt as low as possible on the

hips and not on the child's waist.

■ **Expectant mothers**

Expectant mothers also need to use the seat belts. They should consult their doctor for specific recommendations. The lap belt should be worn securely and as low as possible over the hips, not over the waist.

■ **Maintenance**



CAUTION

- **Keep the belts free of polishes, oils, chemicals and particularly battery acid.**
- **Never attempt to make modifications or changes that will prevent the seat belt from operating properly.**

To clean the seat belts, use a mild soap and lukewarm water. Never bleach or dye the belts because this could seriously affect their strength.

Inspect the seat belts and attachments including the webbing and all hardware periodically for cracks, cuts, gashes, tears, damage, loose bolts or worn areas. Replace the seat belts even if only minor damage is found.

Child restraint systems



WARNING

- Never let a passenger hold a child on his or her lap while the vehicle is moving. The passenger cannot protect the child from injury in a collision, because the child will be caught between the passenger and objects inside the vehicle. Additionally, holding a child in your lap or arms in the front seat exposes that child to another serious danger. Since the SRS AIRBAG deploys with considerable speed and force, the child could be injured or even killed.
- Be sure to put children aged 12 and under in the rear seat properly restrained at all times. The SRS AIRBAG deploys with considerable speed and force and can injure or even kill children, especially if they are 12 years of age and under and are not restrained or improperly restrained. Because children are lighter and weaker than adults, their risk of being injured from deployment is greater. For that reason, be sure to secure ALL types of child restraint devices (including forward facing child seats) in the REAR seats at all times. You should choose a restraint device which is appropriate for the child's age, height and weight. According to accident statistics, children are safer when properly restrained in the rear seating positions than in the front seating positions.
- **SINCE YOUR VEHICLE IS EQUIPPED WITH A PASSENGER'S SRS AIRBAG, DO NOT INSTALL A REARWARD FACING CHILD SEAT IN THE FRONT PASSENGER'S SEAT. DOING SO RISKS SERIOUS INJURY OR DEATH TO THE CHILD BY PLACING THE CHILD'S HEAD TOO CLOSE TO THE SRS AIRBAG.**
- Children should be properly restrained in the rear seat at all times. Never allow a child to stand up, or to kneel on the front passenger's seat. The SRS AIRBAG deploys with considerable force and can injure or even kill the child.

Secure child restraint devices in the REAR seats at all times.



OM-H2406



Never install rearward facing child seat in the front passenger's seat.

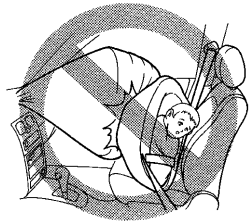

HB0306



Never allow a child to stand up, or to kneel on the front passenger's seat or any other seat

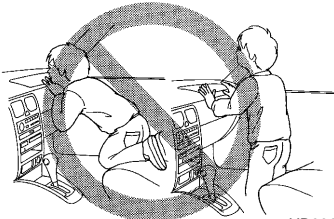

HB0307



Never hold a child on your lap or in your arms in the front passenger's seat or any other seat.

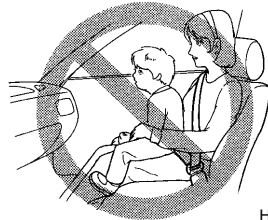

HB0308



WARNING

- Child restraint systems and seat belts can become hot in a vehicle that has been closed up in sunny weather; they could burn a small child. Check the child restraint system before you place a child in it.
- Do not leave an unsecured child restraint system in your vehicle. Unsecured child restraint systems can be thrown around inside of the vehicle in a sudden stop, turn or accident; it can strike and injure vehicle occupants as well as result in serious injuries or death to the child.

Infants and small children should always be placed in an infant or child restraint system in the rear seat while riding in the vehicle. You should use an infant or child restraint system that meets Federal Motor Vehicle

– CONTINUED –

Safety Standard or Canada Motor Vehicle Safety Standard and is appropriate for the child's age and size. All child restraint systems are designed to be secured in vehicle seats by lap belts or the lap portion of a lap/shoulder belt.

Children could be endangered in an accident if their child restraints are not properly secured in the vehicle. When installing the child restraint system, carefully follow the manufacturer's instructions.

According to accident statistics, children are safer when properly restrained in the rear seating positions than in the front seating positions. These statistics also indicate that the safest position for a child restraint system is the center of the rear seat.

All U.S. states and Canadian provinces require that infants and small children be restrained in an approved child restraint system at all times while the vehicle is moving.

■ Installing child restraint systems in the 2-point type seat belt position (Rear center seating position)

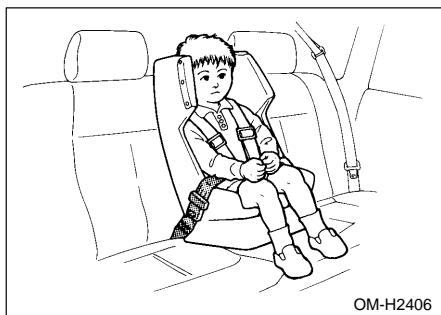

1. Set the child restraint system in the center seating position.
2. Fasten the 2-point type seat belt to the child restraint system following the instructions provided by its manufacturer.
3. Tighten the seat belt.
4. Before having a child sit in the child restraint system, move it back and forth to check if it is firmly secured. Sometimes a child restraint can

be more firmly secured by pushing it down into the seat cushion and then tightening the seatbelt.

If the child restraint system requires a top strap, latch the hook onto the top strap anchor and tighten the top strap.

■ Installing child restraint systems in the 3-point type seat belt position

NOTE

When the child restraint system is no longer in use, remove it and restore the ELR function of the retractor. That function is restored by allowing the seat belt to retract fully.

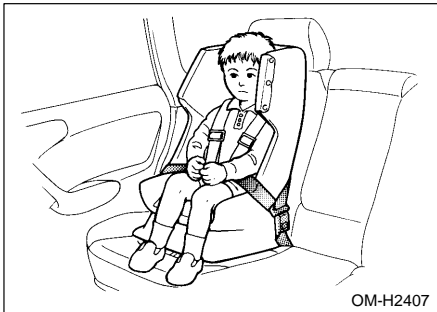

1. Set the child restraint system in the seating position.
2. Fasten the lap and shoulder belts to the child restraint system following the instructions provided by its manufacturer.
3. Take up the slack in the lap belt.
4. Put the shoulder portion of the belt between the rear seatback and the child restraint system.
5. Pull out the seat belt fully from the retractor to change the retractor over from the Emergency Locking Retractor (ELR) to the Automatic Locking Retractor (ALR) function. Then, allow the belt to rewind into the retractor. As the belt is rewinding, clicks will be heard which indicate the retractor functions as ALR.
6. Before having a child sit in the child restraint system, move it back and forth to check if it is firmly secured. Sometimes a child restraint can

– CONTINUED –

be more firmly secured by pushing it down into the seat cushion and then tightening the seat belt.

7. Pull at the shoulder portion of the belt to confirm that it cannot be pulled out (ALR properly functioning).

If the child restraint system requires a top strap, latch the hook onto the top strap anchor and tighten the top strap.

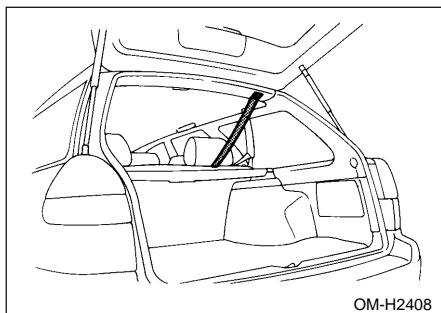

■ Top strap anchors



CAUTION

Always use a genuine top strap anchor.

▼ Installation point

Sedan

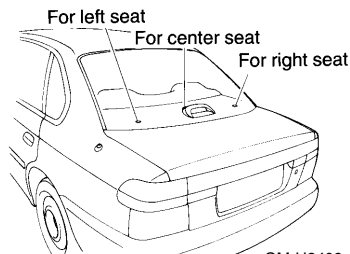

Wagon

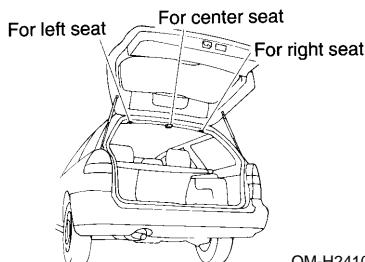

- **Sedan:** Anchor installation points are located under the covers on the rear shelf.
- **Wagon:** Anchor installation points are located under the covers at the rear edge of the roof.

▼ **Top strap anchor installation (for Canada models)**

All vehicles built for sale in Canada include an anchor kit in the glove compartment.

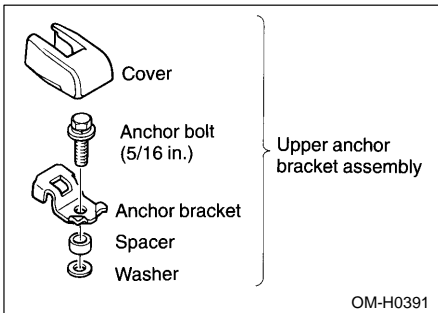

1. Take the anchor kit out and make sure that it is assembled as shown in the illustration above.

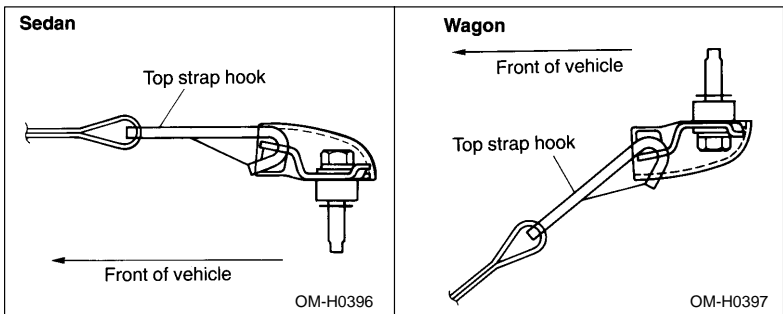

2. Remove the cover from the anchor installation point.
3. Set the anchor at the desired installation point and tighten the bolt until the anchor is firmly secured.
4. Install the anchor plate cover.

– CONTINUED –

Please contact your SUBARU dealer about any questions you may have regarding the installation of the top strap anchor.

▼ **Top strap anchor installation (for U.S. models)**

Vehicles built for sale in U.S. do not include an anchor kit in the glove compartment. However, the anchor kit and installation instructions are available from your SUBARU dealer. You can also follow the installation instructions for Canada models.

***SRS AIRBAG (Supplemental Restraint System Airbag)**

*SRS: This stands for supplemental restraint system. This name is used because the AIRBAG system supplements the vehicle's seat belts.

■ Vehicle with driver's and front passenger's SRS AIRBAGs and lap/shoulder restraints



WARNING

- **To obtain maximum protection in the event of an accident, the driver and all passengers in the vehicle should always wear seat belts when the vehicle is moving. The SRS AIRBAG does not do away with the need to fasten seat belts. In combination with the seat belts, it offers the best combined protection in case of a serious accident.**

Not wearing a seat belt increases the chance of severe injury or death in a crash even when the car has the SRS AIRBAG.

- **For instructions and precautions concerning the seat belt system, see the sections 3-point Type Seat Belts and 2-point Type Seat Belts in this chapter.**

- **Do not sit or lean unnecessarily close to the SRS AIRBAG. The SRS AIRBAG deploys with considerable speed – faster than the blink of an eye – and force to protect in high speed collisions. However, the force of an SRS AIRBAG can injure an occupant whose body is too close to SRS AIRBAG. It is also important to wear your seat belt to help avoid injuries that can result when the**

SRS AIRBAG contacts an occupant not in proper position such as one thrown toward the front of the car during pre-accident braking.

- The SRS AIRBAGs deploy with considerable speed and force. Occupants who are out of proper position when the SRS AIRBAG deploys could suffer very serious injuries. Because the SRS AIRBAG needs much space for deployment, the driver should always sit upright and well back in the seat as far from the steering wheel as practical while still maintaining full vehicle control and the front passenger should move the seat as far back as possible and sit upright and well back in the seat.
- Do not place any objects over the SRS AIRBAG cover or between you and the SRS AIRBAG. If the SRS AIRBAG deploys, those objects could interfere with its proper operation and could be propelled inside the car and cause injury.

Adjust the seatback to upright position. Sit well back and upright.



Move the seat as far from the steering wheel as practical.

HS0233

Adjust the seatback to upright position. Sit well back and upright.

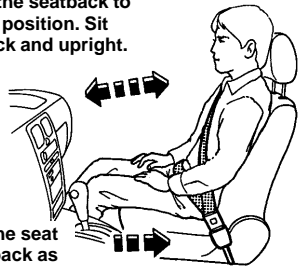

Move the seat as far back as possible.

HB0290

WARNING

- Be sure to put children aged 12 and under in the rear seat properly restrained at all times. The SRS AIRBAG deploys with considerable speed and force and can injure or even kill children, especially if they are 12 years of age and under and are not restrained or improperly restrained. Because children are lighter and weaker than adults, their risk of being injured from deploy-

– CONTINUED –

ment is greater. For that reason, we strongly recommend that ALL children (including those in child seats and those that have outgrown child restraint devices) sit in the REAR seat properly restrained at all times in a child restraint device or in a seat belt, whichever is appropriate for the child's age, height and weight. Be sure to secure ALL types of child restraint devices (including forward facing child seats) in the REAR seats at all times.

According to accident statistics, children are safer when properly restrained in the rear seating positions than in the front seating positions.

For instructions and precautions concerning the child restraint system, see the Child Restraint System section in this chapter.

- **NEVER INSTALL A REARWARD FACING CHILD SEAT IN THE FRONT SEAT. DOING SO RISKS SERIOUS INJURY OR DEATH TO THE CHILD BY PLACING THE CHILD'S HEAD TOO CLOSE TO THE SRS AIRBAG.**

- Never allow a child to stand up, or to kneel on the front passenger's seat, or never hold a child on your lap or in your arms. The SRS AIRBAG deploys with considerable force and can injure or even kill the child.

Put children in the REAR seat properly restrained at all times.



HB0291

⚠ Never install rearward facing child seat in the front passenger's seat.

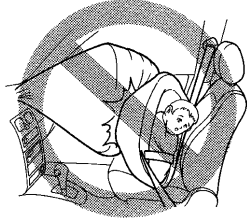

HB0306

⚠ Never allow a child to stand up, or to kneel on the front passenger's seat.

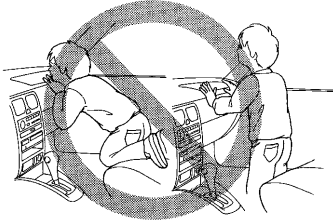

HB0307

⚠ Never hold a child on your lap or in your arms.

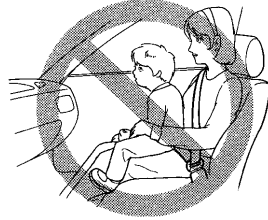

HB0308

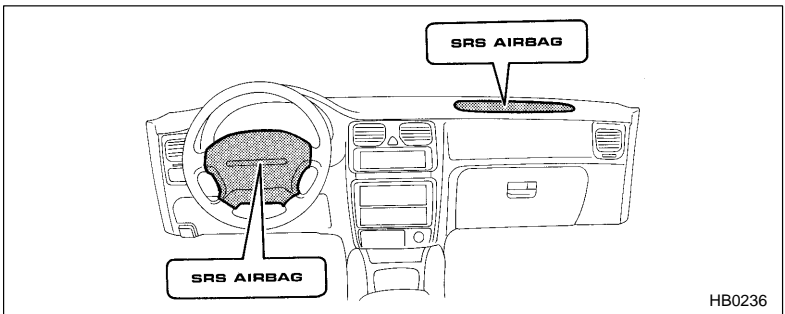

HB0236

The driver's side SRS AIRBAG is stored in the center portion of the steering wheel. The passenger's side SRS AIRBAG is stored near the top of the dashboard under the cover marked "SRS AIRBAG".

The SRS (Supplemental Restraint System) AIRBAG in your vehicle af-

- CONTINUED -

fords the driver and front seat passenger additional protection during a moderate to severe frontal or front-angled collision. This system is available for the driver and front seat passenger and is designed to supplement the protection provided by the seat belt. In a moderate to severe frontal or front-angled collision, the SRS AIRBAG supplements the seat belt by reducing the impact on the driver's and front passenger's head and chest.

The SRS AIRBAG is designed to deploy in the event of an accident involving a moderate to severe frontal or front-angled collision. It is basically not designed to deploy in lesser frontal impacts because the necessary protection can be achieved by the seat belt alone. Also, it is basically not designed to deploy in side or rear impacts or in roll-over accidents because SRS AIRBAG deployment would not help the occupant in those situations. The SRS AIRBAG is designed to function on a one-time-only basis. In the event that the SRS AIRBAG is deployed, replacement of the system should be performed only by an authorized SUBARU dealer. When the components of the SRS AIRBAG are replaced, use only genuine SUBARU parts.

NOTE

When you sell your vehicle, we urge you to explain to the buyer that it is equipped with SRS AIRBAGs by alerting him or her to the applicable section in this owner's manual.

■ SRS AIRBAG system operation



CAUTION

- **When the SRS AIRBAG deploys, some smoke will be released. This smoke could cause breathing problems for people with a history of asthma or other breathing trouble. If you or your passengers have breathing problems after SRS AIRBAG deploys, get fresh air promptly.**
- **Do not touch the SRS AIRBAG system components around the steering wheel and dashboard with bare hands right after deployment. Doing so can cause burns because the components can be very hot as a result of deployment.**

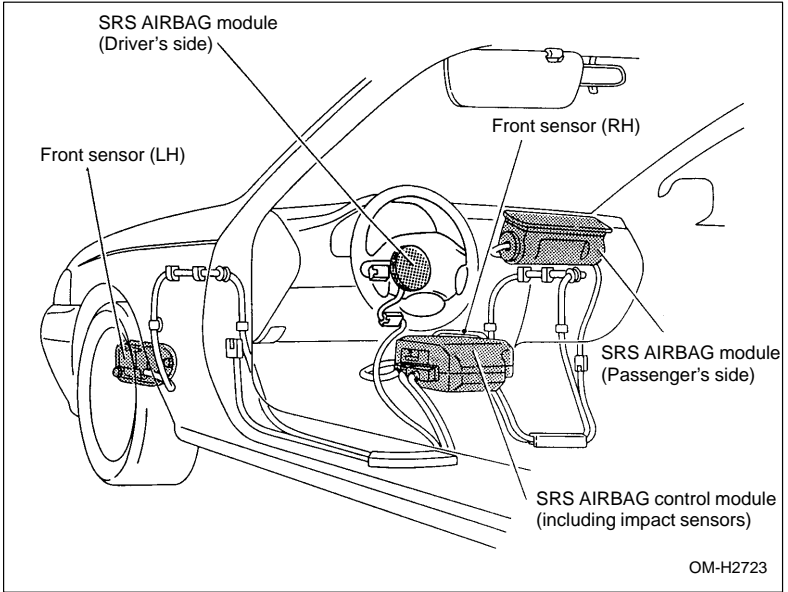

Driver's side

Passenger's side

SRS AIRBAGS deploy as soon as a collision occurs.

After deployment, SRS AIRBAGS start to deflate immediately so that the driver's vision is not obstructed.

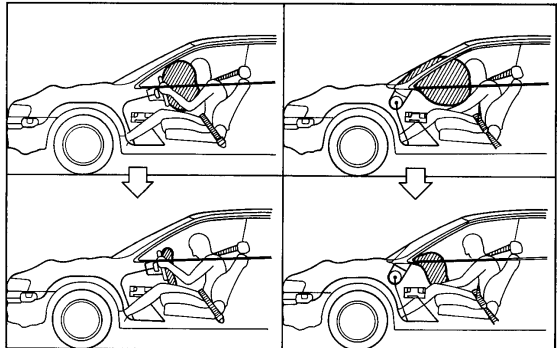

OM-H0384

– CONTINUED –

The SRS AIRBAG can function only when the ignition switch is in the “ON” position.

If the front sensor and impact sensors in the airbag control module detect a certain predetermined amount of force during a frontal or front-angled collision, the control module sends signals to the airbag modules instructing them to inflate the SRS AIRBAGs. Then both airbag modules produce gas by chemical reaction, which instantly inflates driver’s and passenger’s SRS AIRBAGs. After the deployment, the SRS AIRBAGs immediately start to deflate so that the driver’s vision is not obstructed. The time required from detecting impact to deflating of the SRS AIRBAGs after deployment is shorter than the blink of eye.

Although it is highly unlikely that the SRS AIRBAG would activate in a non-accident situation, should it occur, the bag will deflate quickly, not obscuring vision and will not interfere with the driver’s ability to maintain control of the vehicle.

When the SRS AIRBAG deploys, a sudden, fairly loud inflation noise will be heard and some smoke will be released. These occurrences are a normal result of the chemical reaction in the airbag module. This smoke does not indicate a fire in the vehicle.

SRS AIRBAG deployment depends on the level of force experienced in the passenger compartment during a collision. That level differs from one type of collision to another, and it may have no bearing on the visible damage done to the vehicle itself.

▼ Examples of the types of accidents in which the SRS AIRBAG is unlikely to deploy.

There are many types of collisions which might not necessarily require SRS AIRBAG deployment. If the vehicle strikes an object, such as a telephone pole or sign pole, or if it slides under a truck's load bed, or if it sustains an oblique offset frontal impact, the SRS AIRBAG may not deploy depending on the level of accident forces involved.

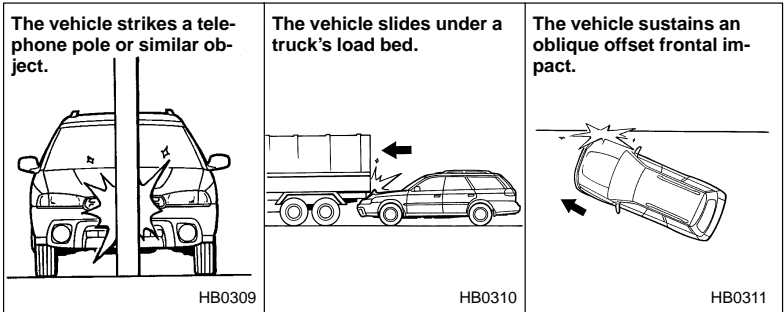

▼ Examples of the types of accidents in which the SRS AIRBAG will basically not deploy.

The SRS AIRBAG is basically not designed to deploy if it is struck from side or from behind, or if it rolls onto its side or roof, or if it is involved in a low-speed frontal collision.

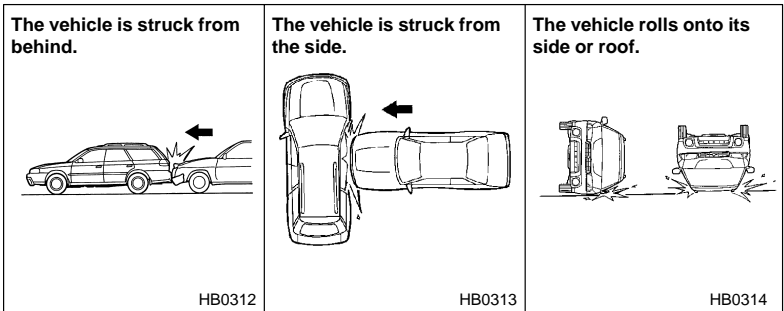

■ System monitors

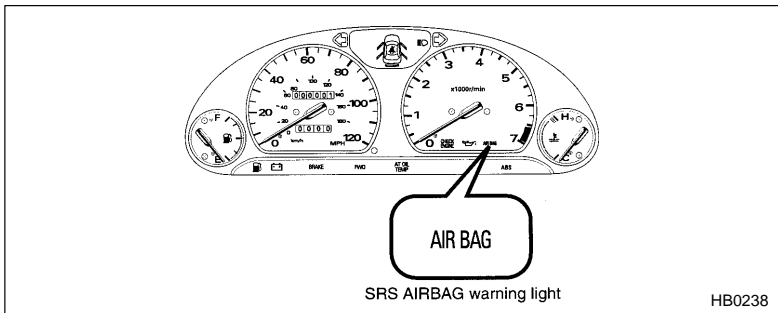

A diagnostic system continually monitors the readiness of the SRS AIRBAG while the vehicle is being driven. The SRS AIRBAG warning light will show normal system operation by lighting for about 6 seconds when the ignition key is first turned to the “ON” position and then turning off.

The following components are monitored by the indicator:

- Right front sensor
- Left front sensor
- AIRBAG control module (including impact sensors)
- AIRBAG module (driver’s side)
- AIRBAG module (passenger’s side)
- All related wiring

In the event of a malfunction indicated by any of following, the vehicle should be taken promptly to your nearest SUBARU dealer to have the system checked. Unless checked and repaired, the SRS AIRBAG will not function reliably:

- Flashing or flickering of the warning light.
- Failure of the warning light to illuminate when the ignition switch is first turned to the “ON” position.
- Continuous illumination of the warning light.
- Illumination of the warning light while driving.

■ System servicing



WARNING

- When discarding an airbag module or scrapping the entire car damaged by a collision, consult your SUBARU dealer.
- The SRS AIRBAG has no user-serviceable parts. Tampering with or disconnecting the system's wiring could result in accidental inflation of the airbag or could make the system inoperative, which may result in serious injury. The wiring harnesses of the SRS AIRBAG system are covered with yellow insulation and the connectors of the system are yellow for easy identification. Do not use electrical test equipment on any circuit related to the SRS AIRBAG system. For required servicing of the SRS AIRBAG, see your nearest SUBARU dealer.



CAUTION

The front sensors are located in both front fenders and the SRS AIRBAG control module including the impact sensors is located under the center console. If you need service or repair in those area or near the steering wheel and column, we recommend that you have an authorized SUBARU dealer perform the work.

To ensure its long-term reliability, the SRS AIRBAG must be inspected by a SUBARU dealer ten years after the date of manufacture, which is shown on the certification label attached to the driver's door.

NOTE

- If the front part of the vehicle was involved in an accident not of the extent to cause the SRS AIRBAGs to deploy, contact your SUBARU dealer as soon as possible.
- If the pad section of the steering wheel or front passenger's SRS AIRBAG cover is scratched, cracked, or otherwise damaged, contact your SUBARU dealer as soon as possible.

■ Precautions for vehicle modification

WARNING

- Do not put any objects over the steering wheel pad and dashboard. If the SRS AIRBAG deploys, those objects could interfere with its proper operation and could be propelled inside the vehicle and cause injury.
- Do not attach accessories to the windshield, or fit an extra-wide mirror over the rear view mirror. If the SRS AIRBAG deploys, those objects could become projectiles that could seriously injure vehicle occupants.
- To avoid accidental actuation of the system or rendering the system inoperative, which may result in serious injury, no modifications should be made to any components or wiring of the SRS AIRBAG.

This includes the installation of “custom” steering wheels or additional trim material, or badges over the pad section of the steering wheel. Installation of additional electrical/electronic equipment such as a mobile two way radio on or near SRS AIRBAG components and/or wiring is not advisable.

 Do not put any objects over the steering wheel pad and dashboard

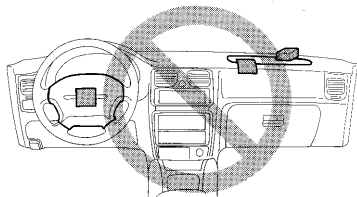

HB0239

 Do not attach accessories to the windshield, or fit an extra-wide mirror over the rear view mirror.

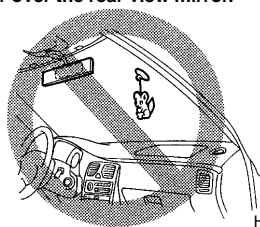

HB0315



CAUTION

Do not perform any of the following modifications. Such modifications can interfere with proper operation of the SRS AIRBAG system.

- Attachment of any equipment (brush bar, winches, snow plow, skid plate, etc.) other than SUBARU genuine accessory parts to the front end.
- Modification of the suspension system and front end structure.
- Installation of a tire of different size and construction from the original tire listed on the tire placard attached to the door jamb.

Always consult your SUBARU dealer if you want to install any accessory parts to your vehicle.